



US 20140141128A1

(19) **United States**

(12) **Patent Application Publication**

Trombetta et al.

(10) **Pub. No.: US 2014/0141128 A1**

(43) **Pub. Date: May 22, 2014**

(54) **BEVERAGE CAPSULE AND PROCESS AND SYSTEM FOR MAKING SAME**

(52) **U.S. Cl.**
CPC *B65D 85/8046* (2013.01); *B65B 1/02* (2013.01)

(71) Applicant: **2266170 Ontario Inc.**, Mississauga (CA)

USPC **426/77; 53/456**

(72) Inventors: **Liberatore A. Trombetta**, Ancaster (CA); **YuCheng Fu**, Mississauga (CA)

(57) **ABSTRACT**

(73) Assignee: **2266170 Ontario Inc.**, Mississauga (CA)

(21) Appl. No.: **14/077,356**

(22) Filed: **Nov. 12, 2013**

Related U.S. Application Data

(60) Provisional application No. 61/725,324, filed on Nov. 12, 2012.

Publication Classification

(51) **Int. Cl.**
B65D 85/804 (2006.01)
B65B 1/02 (2006.01)

A beverage capsule is provided for use in a beverage preparing machine. A system and process for making the beverage capsule is also provided. The beverage capsule includes a body defining an interior space having an opening. A filter is disposed in the body to define an ingredients chamber and an extraction chamber. The filter has an air flow permeability of at least 400 L/s.m². Ingredients are disposed in the ingredients chamber and a cover is dispensed over the opening to seal the interior space. The filter includes a vent region between the top surface of the ingredients and the bottom surface of cover for venting gas through said filter between said ingredients chamber and said extraction chamber. An alternate embodiment includes air flow channels defined in a side wall of body.

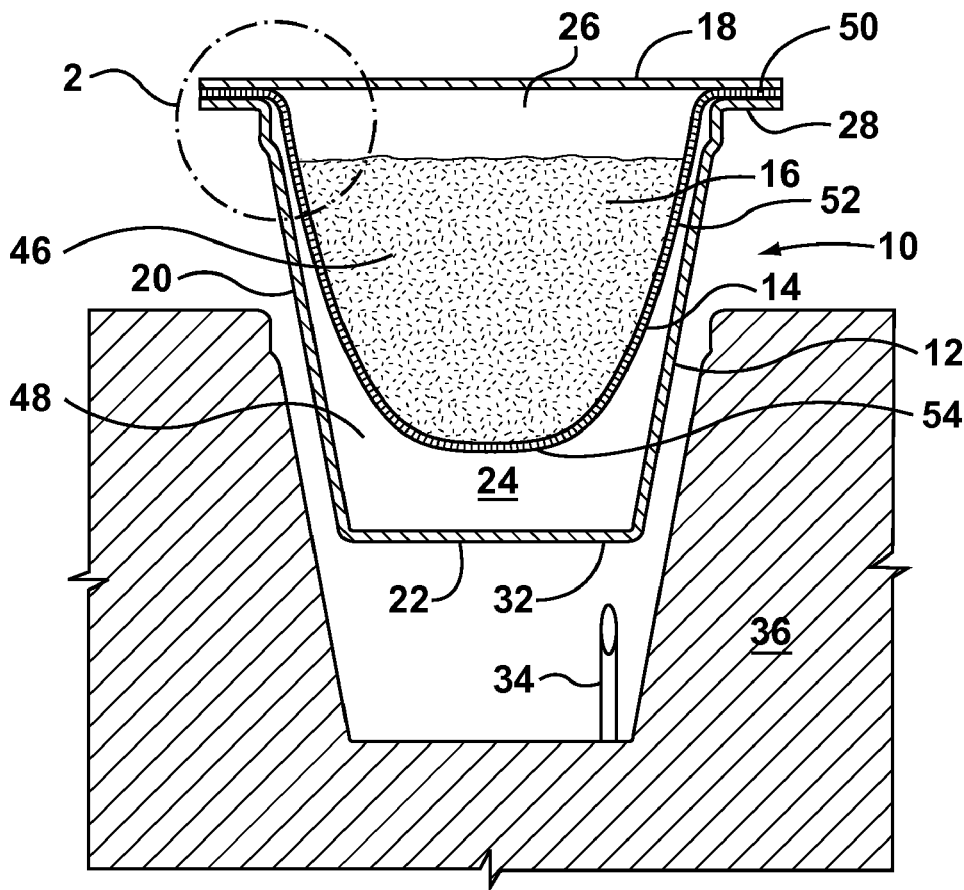

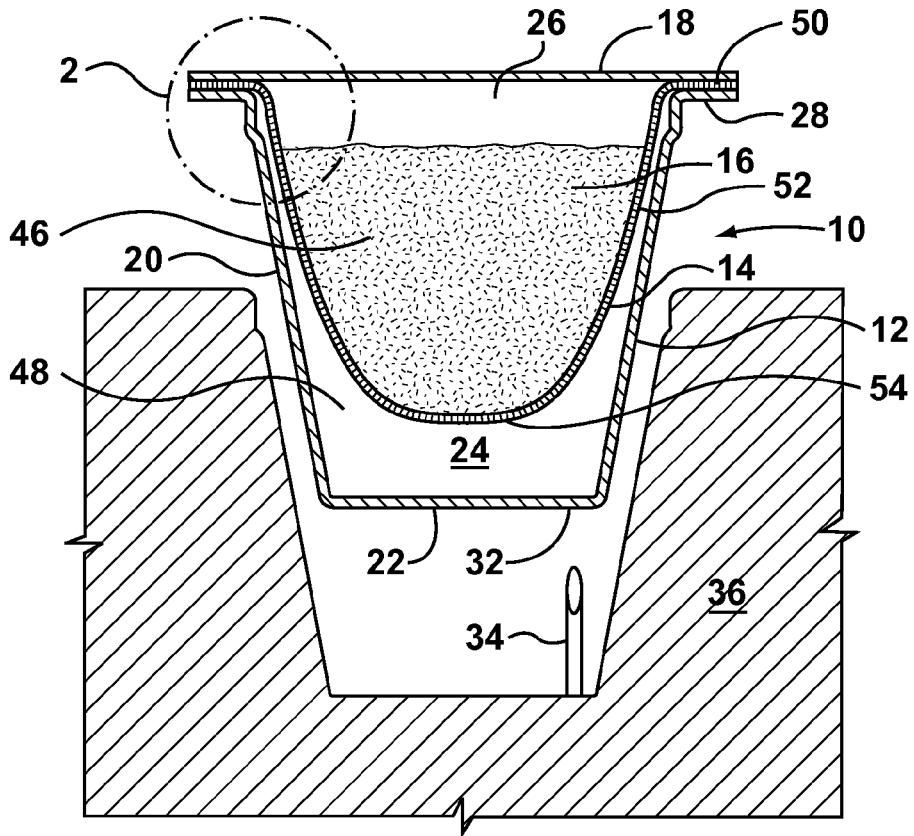

FIG. 1

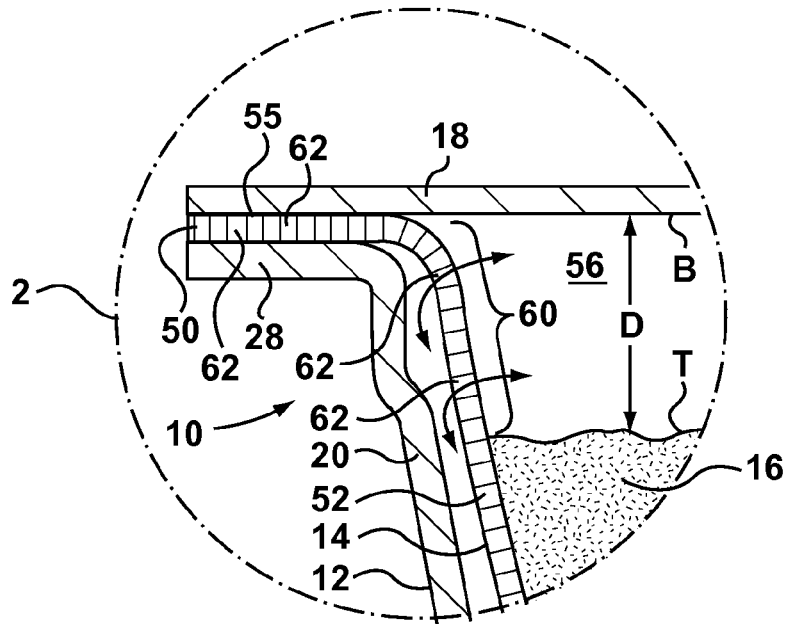

FIG. 2

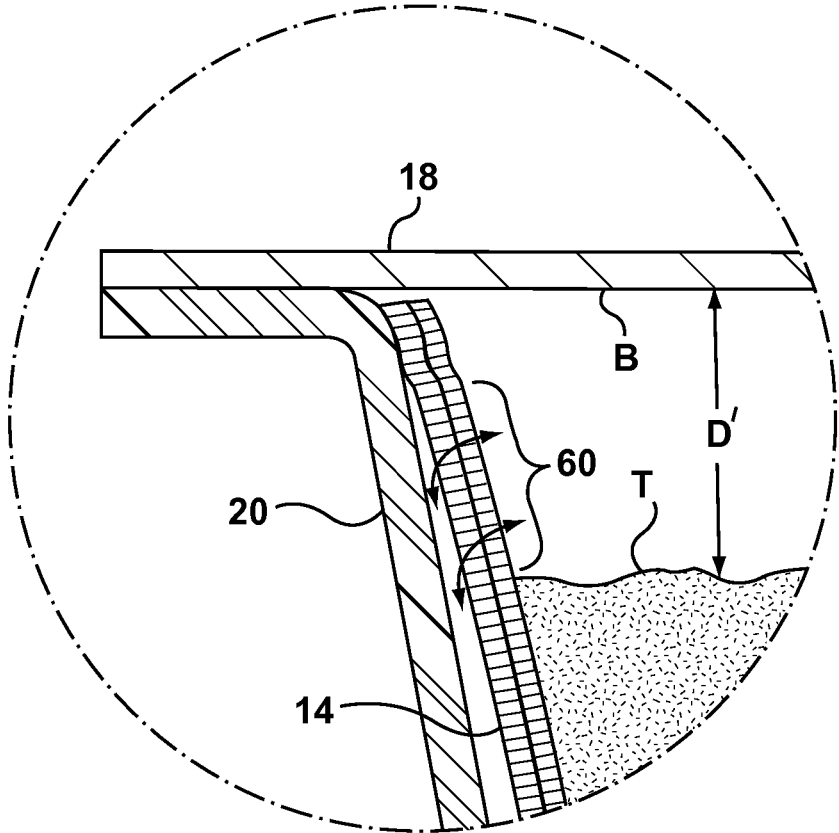

FIG. 3 (Prior Art)

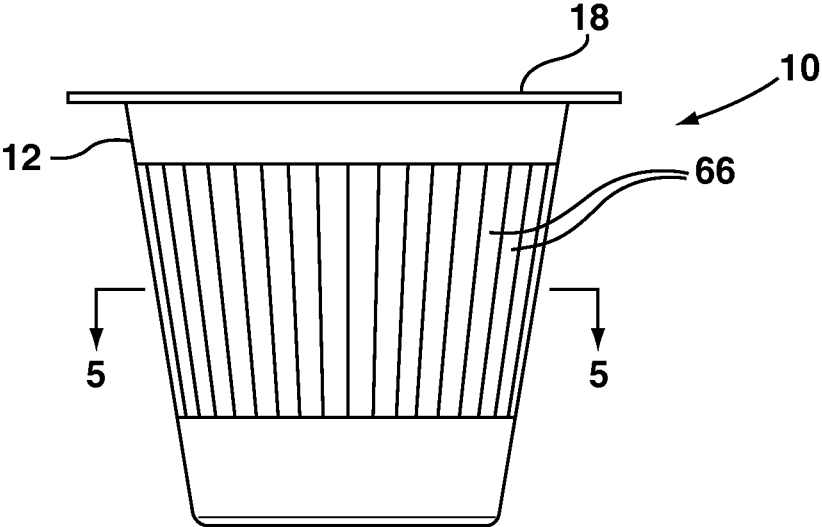

FIG. 4

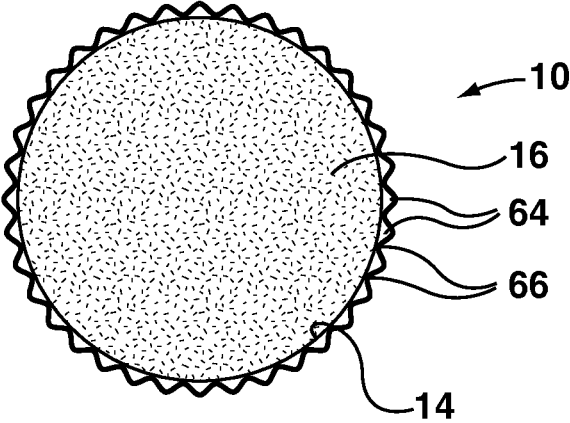

FIG. 5

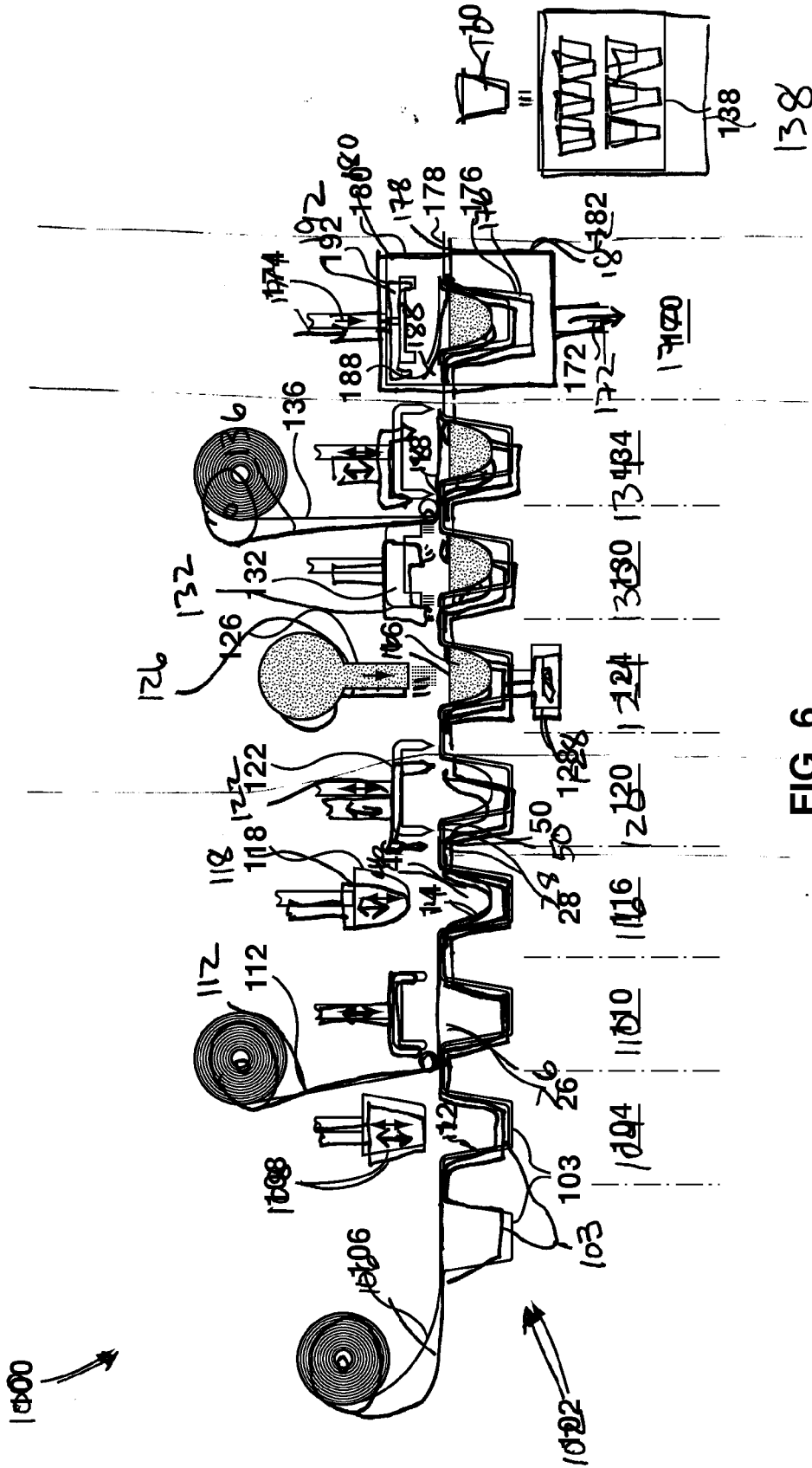

FIG. 6
FIGURE 6

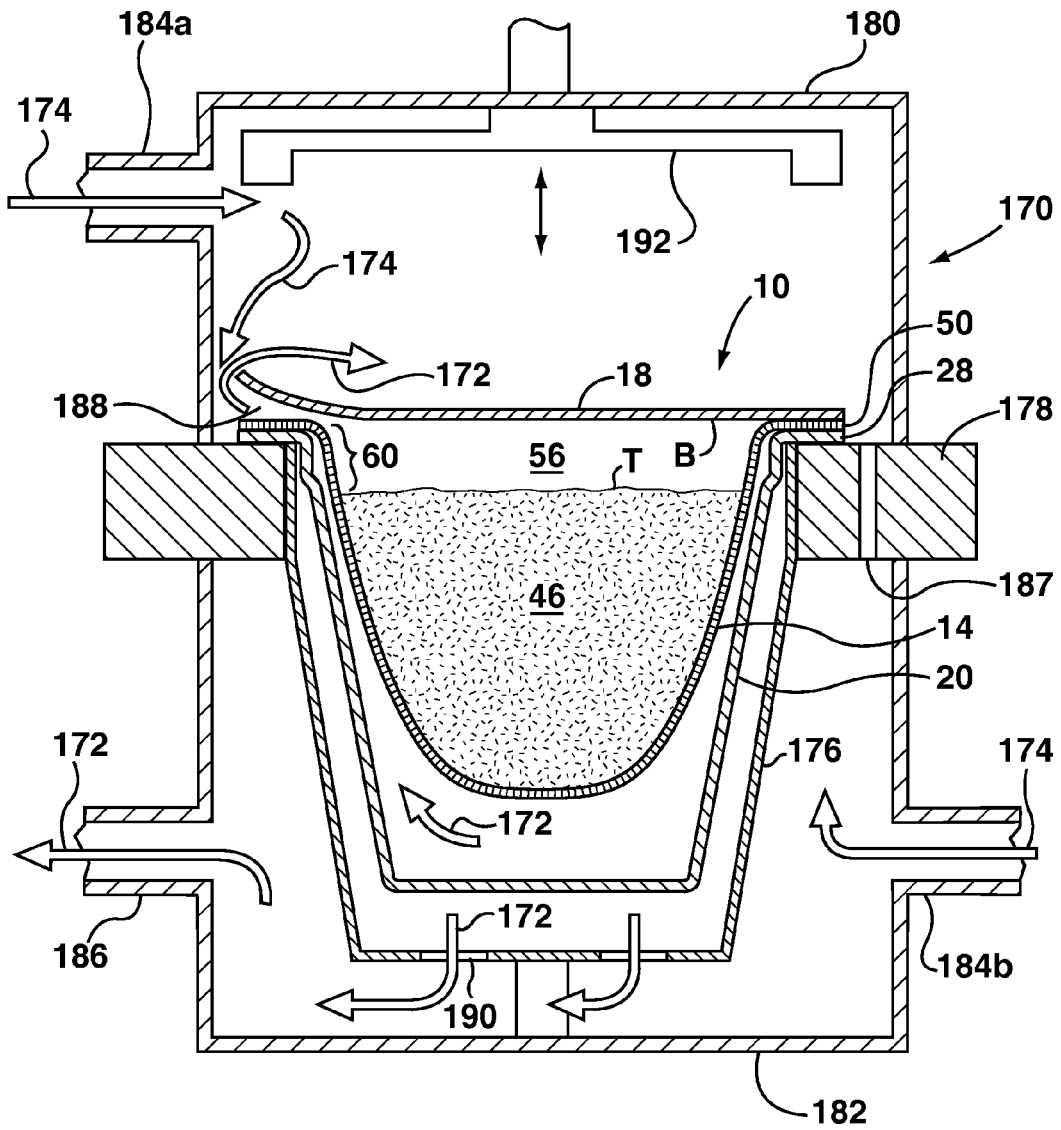

FIG. 7

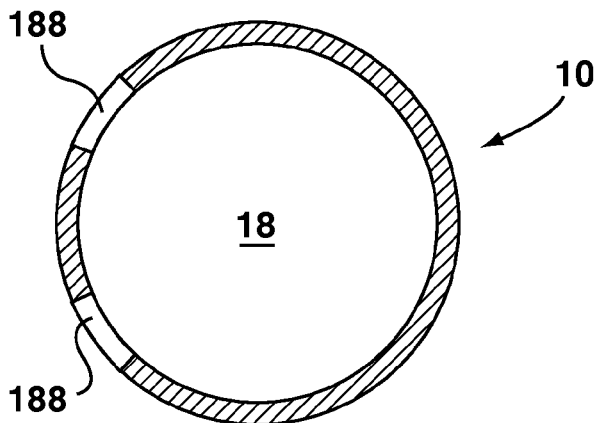

FIG. 8

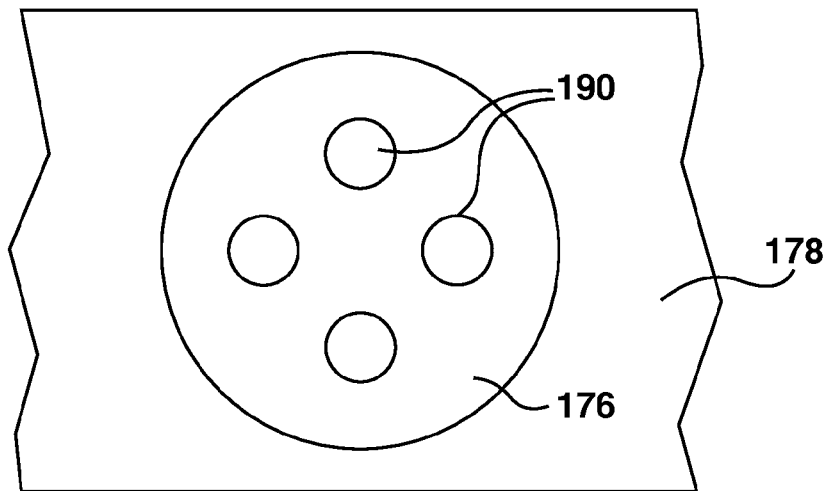

FIG. 9

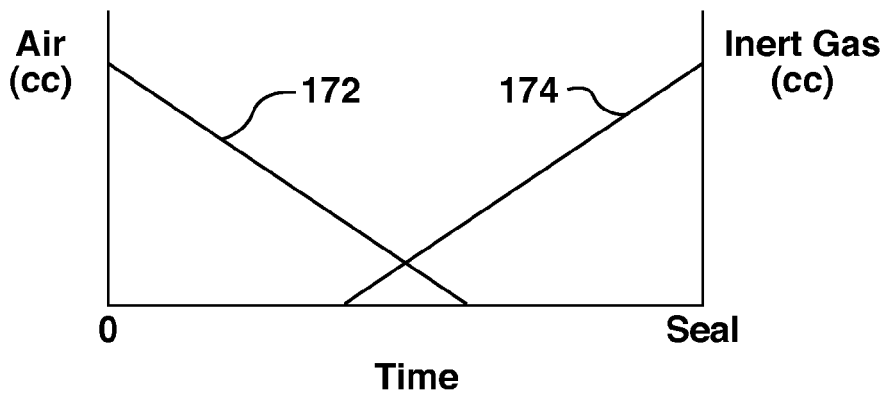

FIG. 10

BEVERAGE CAPSULE AND PROCESS AND SYSTEM FOR MAKING SAME

FIELD

[0001] This specification relates to beverage capsules used in beverage preparing machines and in particular to multi-chamber beverage capsules and a process and system for making same.

BACKGROUND

[0002] The following background discussion is not an admission that anything discussed below is citable as prior art or common general knowledge. The documents listed below are incorporated herein in their entirety by this reference to them.

[0003] Single serve beverage capsules for use in beverage preparing machines are becoming increasingly popular. Such beverage capsules come in a variety of formats for producing beverages such as espresso coffee, drip coffee, tea or hot chocolate.

[0004] Single chamber beverage capsules, such as espresso capsules, have a single chamber defined by a plastic or aluminum body having a foil cover at one end. The chamber is densely packed with ingredients, such as ground coffee, for producing beverages in a high pressure beverage preparing machine. Hot water is injected under pressure by the beverage preparing machine into the single chamber containing the ingredients. As the pressure within the chamber increases the foil cover is forced against raised projections in the capsule holder to the point that the projections penetrate the cover so that the beverage flows through the cover into the user's cup.

[0005] One example of a single chamber beverage capsule is the Nespresso Grands Crus™ capsule. This capsule has an aluminum body with a foil cover. The foil cover is pierced by square protrusions in the capsule holder when hot water is injected under pressure by the beverage preparing machine into the capsule.

[0006] Multi chamber beverage capsules, such as drip coffee capsules, have a first chamber defined by a filter (typically a paper filter) that is loosely packed with ingredients (such as ground coffee) and a second chamber downstream of the first chamber that defines an empty space for receiving a prepared beverage that flows through the filter prior to dispensing into a cup.

[0007] One example of a multi chamber beverage capsule is the Keurig K-Cup™ capsule. This capsule includes a paper filter having a side wall that is sealed to an inside peripheral edge of the capsule. The side wall of the filter is pleated or fluted to define channels extending between the top and bottom of the filter. The channels are intended to improve fluid flow down the side wall of the chamber.

[0008] One advantage of single serve beverage capsules is that each serving contains a fresh supply of ingredients. The freshness of the ingredients is preserved through a modified atmosphere packaging (MAP) process where the air within the capsule is modified such as by replacing the air with an inert gas prior to sealing.

[0009] A problem with multi chamber beverage capsules is that a greater volume of air is contained within the capsule (in the second chamber and within the bed of loosely packed ingredients) which must be evacuated and replaced with an inert gas as part of the MAP process. The location and type of filter, such as the pleated paper filter that is secured to the side

wall of the Keurig K-cup™ capsule, can restrict the rate at which air within the second chamber of the capsules may be evacuated and replaced with an inert gas. This significantly impacts the rate of production for conventional dual chamber capsules such as the Keurig K-cup™ capsules.

[0010] To address this problem, conventional dual chamber capsules, such as the Keurig K-cup™ capsule, are manufactured within a modified atmosphere environment. Specifically, the filling and sealing operations are conducted within an operation chamber in which the air has been replaced with nitrogen.

[0011] This results in manufacturing inefficiencies due to the large volumes of nitrogen required to fill the large space that houses the filling and sealing machinery. Furthermore, the operation requires a longer than desired lead time prior to each manufacturing cycle to replace the air within the operation chamber with nitrogen.

[0012] Another problem with conventional multi chamber capsules, such as the Keurig K-cup™ capsule, is that the brewing cycle is prolonged due to delayed balancing of the pressure differential between the upper and lower chambers during use of the beverage capsule in a beverage preparing machine.

[0013] There is a need for improvements to the beverage capsule and the process and system for making such beverage capsules to address problems such as noted above.

SUMMARY

[0014] In one aspect the invention provides a beverage capsule for use in a beverage preparing machine, the beverage capsule comprising:

[0015] a body defining an interior space;

[0016] a filter disposed in said body to define an ingredients chamber and an extraction chamber, said filter having an air flow permeability of at least 400 L/s.m²;

[0017] ingredients disposed in said ingredients chamber for preparing a desired consumable product; and

[0018] a cover disposed over an opening to said body for sealing said interior space.

[0019] In another aspect the invention provides a beverage capsule for use in a beverage preparing machine, the beverage capsule comprising:

[0020] a body having a side wall extending from an end wall to an opening to define an interior space;

[0021] a plurality of air flow channels defined in an interior surface of said side wall of said body, said air flow channels extending at least partway between said opening and said end wall of said body;

[0022] a filter disposed in said body to define an ingredients chamber and an extraction chamber;

[0023] ingredients disposed in said ingredients chamber for preparing a desired consumable product; and

[0024] a cover disposed over said opening for sealing said interior space.

[0025] In another aspect the invention provides a process for making a beverage capsule for use in a beverage preparing machine, the process comprising the steps of:

[0026] sealing a filter to a body for the beverage capsule to define an ingredients chamber and an extraction chamber, said filter having an air flow permeability of at least 400 L/s.m²; said body having a side wall extending from an end wall to an opening to define an interior space;

[0027] depositing a desired volume of desired ingredients into said ingredients chamber;

[0028] replacing a substantial volume of air within said interior space with an inert gas; and

[0029] sealing a cover to said body to cover said opening.

[0030] In another aspect the invention provides a system for making a beverage capsule for use in a beverage preparing machine, the system comprising:

[0031] a filter sealing station for sealing a filter to a body for the beverage capsule to define an ingredients chamber and an extraction chamber, said filter having an air flow permeability of at least 400 L/s.m², said body having a side wall extending from an end wall to an opening to define an interior space, said opening being surrounded by a flange;

[0032] a dosing station for depositing a desired volume of desired ingredients into said ingredients chamber;

[0033] a cover pre-sealing station for sealing a cover to said flange while maintaining at least one opening; and

[0034] a MAP station for replacing a substantial volume of air within said body with an inert gas and sealing said at least one airflow opening with said cover.

[0035] In another aspect, the invention provides a capsule for use in a machine for preparing consumable products from capsules, the capsule comprising:

[0036] a body defining an interior space;

[0037] a filter disposed in said body to define an ingredients chamber and an extraction chamber, said filter having an air flow permeability of at least 400 L/s.m²;

[0038] ingredients disposed in said ingredients chamber for preparing a consumable product;

[0039] a cover disposed over an opening to said body for sealing said interior space; and

[0040] wherein a vent region is defined in said filter between a top surface of said ingredients and a bottom surface of said cover, said vent region being adapted for venting gas through said filter between said ingredients chamber and said extraction chamber.

[0041] Other aspects and features of the teachings disclosed herein will become apparent, to those ordinarily skilled in the art, upon review of the following description of the specific examples of the specification.

DRAWINGS

[0042] The drawings included herewith are for illustrating various examples of articles, methods, and apparatuses of the present specification and are not intended to limit the scope of what is taught in any way. For simplicity and clarity of illustration, where considered appropriate, reference numerals may be repeated among the drawings to indicate corresponding or analogous elements.

[0043] FIG. 1 is a sectional view of a beverage capsule in accordance with the present invention, the beverage capsule being inserted into a brew chamber for a beverage preparing machine;

[0044] FIG. 2 is an enlarged sectional view of the beverage capsule shown in FIG. 1 as viewed within circle 2;

[0045] FIG. 3 is an enlarged sectional view of a Keurig K-cup™ beverage capsule (Prior Art) corresponding to the view of the beverage capsule shown in FIG. 2;

[0046] FIG. 4 is a front view of another embodiment of beverage capsule in accordance with the present invention;

[0047] FIG. 5 is a sectional view of the beverage capsule shown in FIG. 4 as viewed along lines 5-5;

[0048] FIG. 6 is a schematic sectional view of a system and process for making beverage capsules in accordance with the present invention

[0049] FIG. 7 is a schematic sectional view of a MAP station containing beverage capsules for modified atmosphere packaging in accordance with the present invention;

[0050] FIG. 8 is a top view of a beverage capsule with a substantially sealed cover having access openings in accordance with the present invention;

[0051] FIG. 9 is a top view of the lower chamber of the MAP station showing the vacuum portals;

[0052] FIG. 10 is a graph depicting the modified atmospheric packaging process in accordance with the present invention;

DESCRIPTION OF VARIOUS EMBODIMENTS

[0053] Various apparatuses or methods will be described below to provide examples of the claimed invention. The claimed invention is not limited to apparatuses or methods having all of the features of any one apparatus or method described below or to features common to multiple or all of the apparatuses described below. The claimed invention may reside in a combination or sub-combination of the apparatus elements or method steps described below. It is possible that an apparatus or method described below is not an example of the claimed invention. The applicant(s), inventor(s) and/or owner(s) reserve all rights in any invention disclosed in an apparatus or method described below that is not claimed in this document and do not abandon, disclaim or dedicate to the public any such invention by its disclosure in this document.

[0054] A beverage capsule in accordance with the present invention is shown generally at 10 in the Figures. The term “beverage capsule” is intended to mean a capsule for preparing beverages or other consumable products from desired ingredients as described below.

[0055] Beverage capsule 10 includes a body 12, filter 14, ingredients 16 and cover 18. Body 12 and cover 18 are each formed of multilayered materials that include one or more barrier layers providing barriers against one or more environmental factors such as light, oxygen, and moisture.

[0056] Body 12 includes a side wall 20 and an end wall 22 together defining an enclosed interior space 24. Interior space 24 preferably has a volume in the range of 30 cc to 100 cc for preparing a single serving of beverage and more preferably a volume in the range of 40 cc to 80 cc.

[0057] An opening 26 is defined at one end of body 12. A flange 28 extends around the perimeter of opening 26. End wall 22 includes at least one extraction region 32 adapted for being pierced by at least one extraction needle 34 of a beverage preparing machine 36 for dispensing beverage from the capsule 10 to a user's cup.

[0058] Filter 14 is adapted to be disposed within body 12 to define at least one ingredients chamber 46 in an upper region of the interior space 24 for receiving one or more ingredients 16 and at least one extraction chamber 48 exterior to the ingredients chamber 46 in the interior space 24 for receiving beverage from the at least one ingredients chamber 46 prior to extraction using the extraction needle 34.

[0059] Ingredients 16 may be coffee grounds, tea leaves, chocolate powder, milk powder, instant coffee or any other ingredients or combinations of ingredients that may be used to prepare a beverage or other consumable product. Ingredients requiring filtration (such as coffee grounds or tea leaves) would be deposited within ingredients chamber 46. Ingredients that do not require filtration may be deposited within extraction chamber 48.

[0060] Filter 14 includes a gasket portion 50 and a side wall 52 that extends downwardly from gasket portion 50 to a filter bottom 54. Gasket portion 50 is secured to a top surface 55 of flange 28 preferably by way of a heat seal. Cover 18 is subsequently secured to gasket portion 50 of filter 14 and the top surface 55 of flange 28 of body preferably by way of a heat seal. More details of filter 14 and the manner for securing filter 14 and cover 18 to flange 28 of body 12 are provided in co-pending patent application Ser. No. 13/600,582 which is incorporated in its entirety herein by reference. Alternatively, filter 14 may for example be secured to the interior surface of side wall 20 of body 12 and cover 18 may be secured to the top surface 55 of flange 28 using conventional attachment methods.

[0061] Referring to the enlarged view of beverage capsule 10 in FIG. 2, ingredients 16 are disposed in ingredients chamber 46 with the top surface T of ingredients 16 being spaced a distance D from the bottom surface B of cover 18. A headspace cavity 56 having a volume of between 3 cc to 18 cc and preferably between 5 cc to 10 cc is defined between top surface T of ingredients 16 and bottom surface B of cover 18. The ratio of the volume of headspace cavity 56 to overall volume of interior space 24 preferably is in the range of 5% to 35% and more preferably 10% to 20%.

[0062] A vent region 60 is defined by the portion of side wall 52 of filter 14 that is available for venting (and thus not sealed to body 12) between top surface T of ingredients 16 and bottom surface B of cover 18. Vent region 60 provides a primary region for the venting of gas (such as air and inert gas) through filter 14 between ingredients chamber 46 and extraction chamber 48. Such venting occurs during the MAP process as well as during use of beverage capsule 10 in a beverage preparing machine as pressure differentials between the ingredients chamber 46 and extraction chamber 48 are changing. For a beverage capsule 10 having an interior space 24 adapted for providing a single serving of beverage, vent region 60 preferably has a surface area in the range of 3 to 20 cm² and more preferably between 6 to 15 cm².

[0063] Filter 14, and in particular vent region 60 of filter 14, preferably has an air permeability of at least 400 L/s.m², more preferably at least 1000 L/s.m² and even more preferably at least 1800 L/s.m² (all measurements based on ASTM Standard D737-96 "Standard Test Method for Air Permeability of Textile Fabrics"). By comparison, the pleated paper filter for the Keurig K-cup beverage capsule having a basis weight of 40 grams per square meter (gsm) has an air permeability of approximately 250 L/s.m².

[0064] Preferably, filter 14 is formed of a non-woven fabric filtration material such as polyester, polyethylene or nylon non-woven fabric. The basis weight for filter 14 is in the range of 40 to 150 gsm and more preferably between 80 to 120 gsm.

[0065] Referring to FIG. 3 showing a corresponding enlarged view of a Keurig K-cup™ capsule, it can be seen that the paper filter is adhered to the interior side wall of the capsule with the result that vent region 60 is disposed further down from cover 18 than for the beverage capsule in accordance with an embodiment of the present invention. As a result, the distance D between the top surface T of ingredients 16 and bottom surface B of cover 18 for the beverage capsule in accordance with an embodiment of the present invention may be smaller than distance D' for the Keurig K-Cup™ capsule. This in turn allows for the ingredients to be filled to a higher level for the beverage capsule 10 in accordance with an embodiment of the present invention and thus a greater

volume of ingredients to be disposed in the same size beverage capsule 10 if desired. Preferably distance D can be as small as 5 mm and more preferably as small as 2 mm.

[0066] Preferably, filter 14 is formed of a moldable non-woven filtration material that includes a plurality of multi-component fibers that are bound or interlocked by non-woven manufacturing techniques (such as spun bond techniques) to form a web having channels 62 extending from one side of filter 14 to the other. The desired diameter for channels 62 after forming is between 20 and 100 μm, more preferably between 40 to 80 μm. More details of a preferred filtration material for filter 14 are provided in co-pending patent application Ser. No. 14/074,024 which is incorporated in its entirety herein by reference.

[0067] Filter 14 may alternatively be formed of a polymer sheet, such as polyester or Nylon, which may be perforated or otherwise modified to define channels 62.

[0068] Filter 14 may alternatively be formed from an ultra high molecular weight polyethylene (UHMWPE) which is also a filter material due to the cavities/pores formed during polymerization.

[0069] In an alternative embodiment as shown in FIGS. 4 and 5, body 12 may have air flow channels 64 and ribs 66 defined in the interior surface of sidewall 20 extending at least partway between opening 16 and end wall 22. Preferably, air flow channels 64 are located at least along an upper portion of sidewall 20 adjacent to vent region 60 of filter 14.

[0070] Air flow channels 64 are adapted to provide improved air flow within the beverage capsule 10 along sidewall 20 of body 12 between ingredients chamber 46 and extraction chamber 48 particularly at vent area 60. Air flow channels 64 are adapted to improve air flow sufficiently along the sidewall 20, particularly adjacent vent region 60, to allow a filter 14 having a lower level of air permeability (including conventional paper filters) to be utilized.

[0071] Referring to FIG. 6, a schematic view of a system 100 and process for making beverage capsules 10 in accordance with the present invention is shown.

[0072] System 100 comprises at least one transfer belt 102 having a plurality of capsule holders 103 adapted to cyclically and sequentially transfer capsules 10 from a working station to a following station as described further below. While only a single capsule holder 103 is shown at each station for system 100 it will be understood that transfer belt 102 has multiple capsule holders 103 disposed at each station in order that manufacturing operations may be performed simultaneously on multiple capsules at each station.

[0073] System 100 includes a body forming station 104 for engaging a sheet of moldable multilayered body material 106 with a heated mandrel 108 to form body 12. Capsule holder 103 with body 12 formed in body material 106 is then transferred to a filter sealing station 110. A sheet of moldable nonwoven filter material 112 is sealed to body material 106 at filter sealing station 110 such that filter material 112 covers opening 26 of body 12.

[0074] Capsule holder 103 with filter material 112 sealed to body material 106 is then transferred to a filter forming station 116 where a heated mandrel 118 engages the portion of filter material 112 that extends over opening 26 of body 12 to form a filter 14 into a desired shape to define an ingredients chamber 46 within thermoformed body 12.

[0075] Capsule holder 103 with filter material 112 sealed to body material 106 and filter 14 formed in body 12 is then transferred to a cutting station 120 where a die 122 cuts each

individual body 12 with filter 14 from body material 106. Die 122 is adapted to cut body material 106 to define flange 28 around opening of body 12 with a gasket portion 50 of filter 14 sealed to the top surface of flange 28.

[0076] Capsule holder 103 with separated body 12 with filter 14 is then transferred to a dosing station 124 having an ingredients supplier 126 for supplying a desired amount of ingredients 16 into ingredients chamber 46. A scale 128 weighs beverage capsule 10 to ensure that the desired amount of ingredients 16 have been dosed into ingredients chamber 46.

[0077] Capsule holder 103 then transfers body 12 with filter 14 and ingredients 16 to cleaning station 130 where a vacuum conduit 132 cleans the exposed surface of gasket portion 50 of filter 14 in preparation for sealing with cover 18.

[0078] Capsule holder 103 then transfers body 12 with filter 14 and ingredients 16 to a cover pre-sealing station 134 for receiving a supply of a cover material 136 and pre-sealing a portion of cover 18 to gasket portion 50 of filter 14 and to flange 28 of body 12. Cover pre-sealing station 134 leaves openings 188 along edge of cover 18 for allowing air to be evacuated and inert gas to be flushed into capsule during the MAP process as described in more detail below.

[0079] Partially sealed beverage capsules 10 are then transferred from capsule holders 103 in transfer plate 102 to corresponding capsule holders 176 disposed within a transfer plate 178 using a pick-and-place device (not shown) or other suitable mechanism. Capsule holders 176 and transfer plate 178 are specially adapted for use during the MAP process as described further below.

[0080] Transfer plate 178 with partially sealed beverage capsules 10 disposed in capsule holders 176 is then moved to a MAP station 170 for execution of the MAP process as described below. Once the MAP process is complete, openings 188 in cover 18 are sealed with sealer 192 and the finished beverage capsule 10 is transferred using a pick-and-place device (not shown) or other suitable mechanism to a collection station 138 for subsequent packaging into boxes (not shown).

[0081] Referring to FIG. 7, MAP station 170 that is adapted for replacing air 172 within beverage capsule 10 with a desired inert gas 174 is shown. MAP station 170 is sized and configured to accommodate multiple beverage capsules 10 disposed in multiple capsule holders 176 supported along a row by the transfer plate 178. The transfer plate 178 is adapted to be transferred to and from MAP station 170 as part of the overall manufacturing process as described above.

[0082] MAP station 170 comprises an upper chamber 180 and a lower chamber 182 that each move between an open position (not shown), where upper chamber 180 and lower chamber 182 are spaced a sufficient distance apart in order that transfer plate 178 containing beverage capsules 10 may be transferred to or from MAP station 170, and a closed position, where upper chamber 180 and lower chamber 182 form an airtight seal against transfer plate 178 in order that the MAP process may be conducted.

[0083] Upper chamber 180 includes a first inert gas inlet 184a connected to a source (not shown) of a desired inert gas 174, such as nitrogen or carbon dioxide, for supplying inert gas 174 under pressure to upper chamber 180. Lower chamber 182 includes a second inert gas inlet 184b connected to a source (not shown) of a desired inert gas 174, such as nitrogen or carbon dioxide, for supplying inert gas 174 under pressure to lower chamber 182.

[0084] Lower chamber 182 further includes an outlet 186 connected to a vacuum generator (not shown) for creating a vacuum within MAP station 170 when it is in its closed position for removing air from upper and lower chambers 180 and 182 as well as interior space 24 of beverage capsules 10 contained within MAP station 170.

[0085] Referring to FIG. 8, beverage capsule 10 has a portion of cover 18 that is sealed to gasket portion 50 of filter and flange 28 of body 12 and at least one portion of cover 18 that is left unsealed to provide at least one opening 188 for air 172 to be drawn out of beverage capsule and inert gas 174 to be supplied into beverage capsule 10. Preferably at least two openings 188 are provided at cover 18 with each opening 188 occupying at least 10% and preferably at least 20% of the circumference of flange to provide sufficient space for air 172 or inert gas 174 to flow efficiently through openings 188.

[0086] Referring back to FIG. 7, port 187 extends through transfer plate 178 to permit air 172 and inert gas 174 to flow between upper chamber 180 and lower chamber 182 during the performance of the MAP process. Capsules 10 are preferably disposed in capsule holders 176 with openings 188 being located on the side of transfer plate that is opposite to the location of port 187 in order that the flow of air 172 urges the unsealed portion of cover 18 away from flange to expose openings 188.

[0087] As shown in FIG. 9, a plurality of openings 190 are defined in the base of capsule holder 176 to allow the vacuum created in lower chamber 182 to also draw air from within capsule holder 176 as well as from within beverage capsule 10. Thus air 172 is drawn from beverage capsule 10 through openings 188 in cover 18 into lower chamber 182 through port 187 and out to vacuum generator through outlet 186.

[0088] MAP station 170 further includes a heat sealer 192 that is adapted to be moved into engagement with the edge portion of cover 18 over flange 28 once the MAP process is complete to close openings 188 and fully seal cover 18 to gasket portion 50 of filter 14 and flange 28 of body 12.

[0089] Referring to FIG. 10, it may be seen that air 172 is initially withdrawn from beverage capsule 10 prior to initiating the supply of inert gas 74. It may be seen that the supply of inert gas 174 is initiated after a predetermined period for removal of air within MAP station 170 including from within beverage capsule 10. It may also be seen that the supply of inert gas 174 is started before the air removal finished in order to minimize the gas turbulence in the evacuation process

[0090] Once sufficient air 172 is removed from beverage capsule 10 and replaced with inert gas 174, the openings 188 in cover 18 are sealed with sealer 192 to fully seal the interior space 24 of beverage capsule 10. It is desirable that sufficient air 172 is removed from beverage capsule 10 to provide an oxygen level of less than 2% and more preferably less than 1%.

[0091] Referring to Table 1 below, the preferred parameters for the MAP process and beverage capsule 10 in accordance with the present invention are provided. Advantageously, the MAP process may be conducted more efficiently and at a greater rate of production than for conventional beverage capsules such as Keurig K-cup™ beverage capsules.

TABLE 1

MAP Station Parameters			
Function	Parameters	Preferred range	More preferred range
Vacuum	Pressure	5-100 KPa	10-80 KPa
	Time	0.5-4 sec	1-3 sec
Inert gas supply	Pressure	20-300 KPa	50-150 KPa
	Time	0.02-1.5 sec	0.1-1 sec
Sealing	Pressure	100-800 KPa	300-600 Kpa
	Time	0.2-2 sec	0.5-1.2 sec
	Temp	120-250° C.	150-200° C.

[0092] While the above description provides examples of one or more processes or apparatuses, it will be appreciated that other processes or apparatuses may be within the scope of the accompanying claims.

I/We claim:

1. A beverage capsule for use in a beverage preparing machine, the beverage capsule comprising:

- a body defining an interior space;
- a filter disposed in said body to define an ingredients chamber and an extraction chamber, said filter having an air flow permeability of at least 400 L/s.m²;
- ingredients disposed in said ingredients chamber for preparing a consumable product; and
- a cover disposed over an opening to said body for sealing said interior space.

2. A beverage capsule as claimed in claim 1, wherein said filter has a basis weight in the range of 40 to 150 gsm.

3. A beverage capsule as claimed in claim 1, wherein a vent region is defined in said filter between a top surface of said ingredients and a bottom surface of said cover, said vent region being adapted for venting gas through said filter between said ingredients chamber and said extraction chamber, said vent region having a surface area no less than 3 cm².

4. A beverage capsule as claimed in claim 3, wherein said vent region is disposed between 0-5 mm below said bottom surface of cover.

5. A beverage capsule as claimed in claim 1, wherein the spacing between a top surface of said ingredients disposed in said ingredients chamber and a bottom surface of said cover is between 2-5 mm.

6. A beverage capsule for use in a beverage preparing machine, the beverage capsule comprising:

- a body having a side wall extending from an end wall to an opening to define an interior space;
- a plurality of air flow channels defined in an interior surface of said side wall of said body, said air flow channels extending at least partway between said opening and said end wall of said body;
- a filter disposed in said body to define an ingredients chamber and an extraction chamber;
- ingredients disposed in said ingredients chamber for preparing a consumable product; and
- a cover disposed over said opening for sealing said interior space.

7. A beverage capsule as claimed in claim 6, wherein a vent region is defined in said filter between a top surface of said ingredients and a bottom surface of said cover, said vent region being adapted for venting gas through said filter between said ingredients chamber and said extraction chamber.

8. A beverage capsule as claimed in claim 7, wherein said air flow channels are located adjacent to said vent region of said filter.

9. A beverage capsule as claimed in claim 6, wherein said air flow channels are defined between ribs extending at least partway between said opening and said end wall of said body.

10. A process for making a beverage capsule for use in a beverage preparing machine, the process comprising the steps of:

- sealing a filter to a body for the beverage capsule to define an ingredients chamber and an extraction chamber, said filter having an air flow permeability of at least 400 L/s.m², said body having a side wall extending from an end wall to an opening to define an interior space;
- depositing a desired volume of desired ingredients into said ingredients chamber;
- replacing a substantial volume of air within said interior space with an inert gas; and
- sealing a cover to said body to cover said opening.

11. A process as claimed in claim 10, wherein a vent region is defined in said filter between a top surface of said ingredients and a bottom surface of said cover, said vent region being adapted for venting gas through said filter between said ingredients chamber and said extraction chamber, said vent region having a surface area no less than 3 cm².

12. A process as claimed in claim 11, wherein said vent region is disposed between 0-5 mm below said bottom surface of cover.

13. A process as claimed in claim 10, wherein the spacing between a top surface of said ingredients disposed in said ingredients chamber and a bottom surface of said cover is between 2-5 mm.

14. A system for making a beverage capsule for use in a beverage preparing machine, the system comprising:

- a filter sealing station for sealing a filter to a body for the beverage capsule to define an ingredients chamber and an extraction chamber, said filter having an air flow permeability of at least 400 L/s.m², said body having a side wall extending from an end wall to an opening to define an interior space, said opening being surrounded by a flange;
- a dosing station for depositing a desired volume of desired ingredients into said ingredients chamber;
- a cover pre-sealing station for sealing a cover to said flange while maintaining at least one opening; and
- a MAP station for replacing a substantial volume of air within said body with an inert gas and sealing said at least one airflow opening with said cover.

15. A system as claimed in claim 14, wherein a vent region is defined in said filter between a top surface of said ingredients and a bottom surface of said cover, said vent region being adapted for venting gas through said filter between said ingredients chamber and said extraction chamber, said vent region having a surface area no less than 3 cm².

16. A process as claimed in claim 15, wherein said vent region is disposed between 0-5 mm below said bottom surface of cover.

17. A process as claimed in claim 14, wherein the spacing between a top surface of said ingredients disposed in said ingredients chamber and a bottom surface of said cover is between 2-5 mm.

18. A capsule for use in a machine for preparing consumable products from capsules, the capsule comprising:

a body defining an interior space;
a filter disposed in said body to define an ingredients chamber and an extraction chamber, said filter having an air flow permeability of at least 400 L/s.m²;
ingredients disposed in said ingredients chamber for preparing a consumable product;
a cover disposed over an opening to said body for sealing said interior space; and
wherein a vent region is defined in said filter between a top surface of said ingredients and a bottom surface of said cover, said vent region being adapted for venting gas through said filter between said ingredients chamber and said extraction chamber.

19. A capsule as claimed in claim **18**, wherein said vent region has a surface area of no less than 3 cm².

20. A beverage capsule as claimed in claim **18**, wherein said vent region is disposed between 0-5 mm below said bottom surface of said cover.

21. A beverage capsule as claimed in claim **8**, wherein the spacing between a top surface of said ingredients disposed in said ingredients chamber and a bottom surface of said cover is between 2-5 mm.

* * * * *