

(19) World Intellectual Property
Organization
International Bureau



(43) International Publication Date
22 September 2005 (22.09.2005)

PCT

(10) International Publication Number
WO 2005/088768 A1

- (51) International Patent Classification⁷: **H01Q 9/04**, 9/26, 1/38
- (21) International Application Number: PCT/IL2005/000295
- (22) International Filing Date: 15 March 2005 (15.03.2005)
- (25) Filing Language: English
- (26) Publication Language: English
- (30) Priority Data: 10/800,019 15 March 2004 (15.03.2004) US
- (71) Applicant (for all designated States except US): **ELTA SYSTEMS LTD.** [IL/IL]; 100 Sderot Itzhak Hanasie, P.O.B. 330, 77102 Ashdod (IL).
- (72) Inventors; and
- (75) Inventors/Applicants (for US only): **HABIB, Laurent** [IL/IL]; 27 Aguefen Street, 79411 Moshav Shapira (IL). **SAMSON, Claude** [IL/IL]; 3 Asavion Street, 76568 Rehovot (IL).
- (74) Agent: **REINHOLD COHN AND PARTNERS**; P.O.B. 4060, 61040 Tel-Aviv (IL).
- (81) Designated States (unless otherwise indicated, for every kind of national protection available): AE, AG, AL, AM, AT, AU, AZ, BA, BB, BG, BR, BW, BY, BZ, CA, CH, CN, CO, CR, CU, CZ, DE, DK, DM, DZ, EC, EE, EG, ES, FI, GB, GD, GE, GH, GM, HR, HU, ID, IL, IN, IS, JP, KE, KG, KP, KR, KZ, LC, LK, LR, LS, LT, LU, LV, MA, MD, MG, MK, MN, MW, MX, MZ, NA, NI, NO, NZ, OM, PG, PH, PL, PT, RO, RU, SC, SD, SE, SG, SK, SL, SM, SY, TJ, TM, TN, TR, TT, TZ, UA, UG, US, UZ, VC, VN, YU, ZA, ZM, ZW.
- (84) Designated States (unless otherwise indicated, for every kind of regional protection available): ARIPO (BW, GH, GM, KE, LS, MW, MZ, NA, SD, SL, SZ, TZ, UG, ZM, ZW), Eurasian (AM, AZ, BY, KG, KZ, MD, RU, TJ, TM), European (AT, BE, BG, CH, CY, CZ, DE, DK, EE, ES, FI, FR, GB, GR, HU, IE, IS, IT, LT, LU, MC, NL, PL, PT, RO, SE, SI, SK, TR), OAPI (BF, BJ, CF, CG, CI, CM, GA, GN, GQ, GW, ML, MR, NE, SN, TD, TG).
- Published:
— with international search report

[Continued on next page]

(54) Title: HIGH GAIN ANTENNA FOR MICROWAVE FREQUENCIES

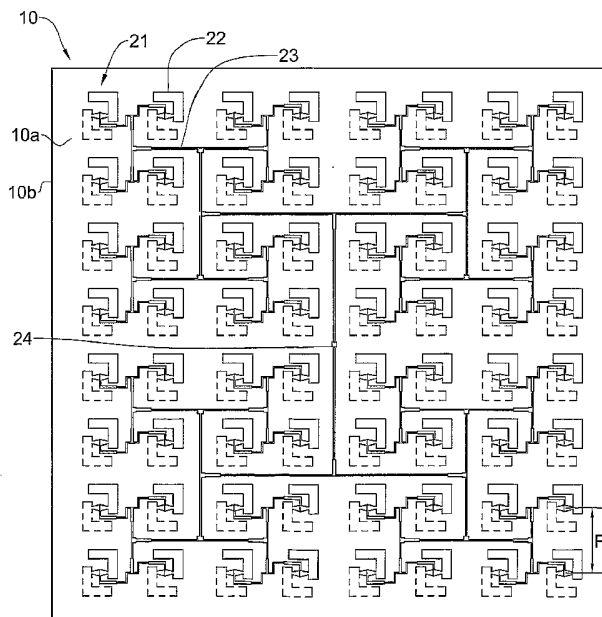

(57) Abstract: A microwave antenna for transmitting and/or receiving electromagnetic waves of at least one predefined frequency and a predefined polarization, the antenna comprises a support with upper and lower faces; at least one pair of substantially identical upper and lower radiating elements disposed on said upper and lower faces; in each pair of said radiating element in the upper face and the corresponding radiating element in the lower face, the phase center of the lower radiating element substantially coincides with the phase center of the upper radiating element.

WO 2005/088768 A1



For two-letter codes and other abbreviations, refer to the "Guidance Notes on Codes and Abbreviations" appearing at the beginning of each regular issue of the PCT Gazette.

High Gain Antenna for Microwave Frequencies

FIELD OF THE INVENTION

This invention relates generally to the field of high-frequency antennas and particularly to the field of planar and conformal antennas for high frequency microwaves.

BACKGROUND OF THE INVENTION

Planar (or flat-plate) and conformal antennas for high frequency microwave transmission (e.g. in various parts of 0.1-40GHz range) are nowadays widely in use for example, in radio broadcasting, mobile communication, and satellite communication. Such antennas can provide circular polarization and linear polarization, based on their specific configuration.

Generally, printed conformal and planar antennas are built on a multilayered substrate structure (e.g. PCB, printed circuit board) and include, *inter alia*, a dielectric substrate and an array of radiating elements and their respective transmission lines, the number of elements depending on their gain as well as on the overall desired gain of the antenna. The radiating elements and the transmission lines are disposed on either one or both sides of the dielectric substrate. Planar antennas are produced, for example, by printing, in the so-called "microstrip" technology or photolithography.

US Patent No. 6,285,323 discloses a flat panel antenna for microwave transmission that comprises at least one PCB, and has radiating elements and transmission lines located on both the first and second sides of the PCB in a complementary manner, such that the transmission lines of the first and second sides overlay one another, and the radiating elements of the second side extend

- 2 -

outwards from the terminations of the transmission lines in the opposite directions, at an angle of 180 degrees from the radiating elements of the first side.

US Patent application No. 2003/0218571 discloses an antenna having linear and circular polarization, which uses dipoles as radiating elements, and has an orthogonal characteristic in both linear and circular polarization, the antenna being embodied in the use of two plates, including the front and rear sides of both plates.

US Patent Application No. 2003/0020665 discloses a planar antenna having a scalable multi-dipole structure for receiving and transmitting high-frequency signals, including a plurality of opposing layers of conducting strips disposed on either side of an insulating (dielectric) substrate.

US Patent No. 6,163,306 discloses a circularly polarized cross dipole antenna comprising a first L-shaped dipole antenna element including a first pair of strip conductors and a first bending portion and a second L-shaped dipole antenna element including a second pair of strip conductors and a second bending portion. The first L-shaped dipole antenna element is arranged in a first region of four regions delimited by crossing lines virtually set within a single plane and the second L-shaped dipole antenna element is arranged in a second region thereof, which is diagonally opposite to the first region. The first bending portion and the second bending portion are close and opposite to each other, such that the first and second L-shaped dipole antenna elements form a cross. The antenna also comprises a parallel-twin-line feeder extended from the first and second bending portions and provided so as to feed power within the single plane.

S. Dragas and M. Sabbadini, in "A Novel Type of Wide Band Circular Polarised Antenna", at the 27th ESA antenna workshop on innovative periodic antennas, present a quasi two-arm spiral radiating element.

US Patents Nos. 5,786,793 and 6,518,935 and US Patent Application No. 2003/0063031 also relate to planar antennas.

There is a need in the art for a new planar/conformal antenna.

SUMMARY OF THE INVENTION

The present invention provides for planar and conformal antennas for transmitting and/or receiving electromagnetic waves of at least one predefined frequency in the range of 0.1-40GHz, and a predefined polarization. The antenna according to the invention provides circular polarization, linear polarization, based on its specific predefined configuration.

According to an embodiment of the invention there is provided a planar or conformal antenna for transmitting and/or receiving electromagnetic waves of at least one predefined frequency and a predefined polarization, the antenna comprising a plane dielectric substrate (PCB) with upper and lower faces; at least one pair of substantially identical upper and lower radiating elements disposed on said upper and lower faces; in each pair of said radiating element in the upper face and the corresponding radiating element in the lower face, the phase center of the lower radiating element substantially coincides with the phase center of the upper radiating element. This allows for high level of antenna performance, e.g. gain of at least 1dB, 1.5dB and more, up to 3dB, when compared to a prior art antenna with the same number of radiating elements, having substantially the same geometrical dimensions; and low axial ratio over large portion of the radiated beam.

According to an embodiment of the invention, the antenna is configured for providing circular polarization, and each of the radiating elements is capable of radiating electromagnetic waves of a circular polarization. According to another embodiment of the invention, the radiating elements comprise bend-shaped elements. According to yet another embodiment of the invention, the above-mentioned bend-shape is an L-shape.

According to an embodiment of the invention, the antenna is configured for providing linear polarization, and the radiating elements comprise radiating elements having first and second branches arranged in an acute angle with respect to each other.

- 4 -

According to an embodiment of the invention there is provided an antenna for transmitting and/or receiving electromagnetic waves of at least one predefined frequency and a predefined polarization, the antenna comprising a multi-layered substrate structure having a dielectric substrate with upper and lower faces; at least one pair of substantially identical upper and lower radiating elements disposed on said upper and lower faces of the dielectric substrate; each radiating element transmitting and/or receiving electromagnetic waves with a phase center located at a predefined position; each radiating element comprising a radiating element and a transmission line, the geometrical dimensions of which depend on said predefined frequency; in each pair of said radiating element in the upper face and the corresponding radiating element in the lower face:

- the transmission lines of the upper and lower elements overlay each other; and
- the radiating elements of the upper and lower elements are located oppositely to each other with respect to a plane perpendicular to the plane of the dielectric substrate, such that the phase center of the lower radiating element substantially coincides with the phase center of the upper radiating element.

According to yet another embodiment of the invention there is provided a method for providing a planar antenna for transmitting and/or receiving electromagnetic waves of at least one predefined frequency and a predefined polarization, the antenna having a dielectric substrate with upper and lower faces; at least one pair of substantially identical upper and lower radiating elements disposed on said upper and lower faces of the dielectric substrate; said radiating elements comprising radiating elements having first and second branches the method comprising:

- determining the planar arrangement and the geometrical dimensions of said first and second branches in accordance with said predefined polarization and said at least one predefined frequency; and

- 5 -

- associating each of the radiating elements in the upper face with a corresponding radiating element in the lower face, such that the phase center of the lower radiating element substantially coincides with the phase center of the upper radiating element.

BRIEF DESCRIPTION OF THE DRAWINGS

In order to understand the invention and to see how it may be carried out in practice, a preferred embodiment will now be described, by way of non-limiting example only, with reference to the accompanying drawings, in which:

Fig. 1 is a cross-sectional view of a flat microwave antenna;

Fig. 2 is a top view of an antenna according to an embodiment of the invention;

Figs. 3a-3b are schematic illustrations of the structure of an element of the antenna of Fig. 2, from respectively, top and side views;

Figs. 4a-4d are schematic illustrations of other structure of elements of the antenna of Fig. 2, in accordance with few other embodiments of the invention;

Figs. 5a-5e illustrate simulated characteristics of an antenna element according to an embodiment of the invention;

Fig. 6 is a schematic illustration of the structure of an element of an antenna according to another embodiment of the invention;

Figs. 7a-7c illustrate simulated characteristics of an antenna element according to another embodiment of the invention;

Fig. 8 is a cross-sectional view of a flat microwave antenna according to another embodiment of the invention; and

Figs. 9a-9b are schematic illustrations of the structure of elements of an antenna according to yet another embodiment of the invention.

DETAILED DESCRIPTION OF SPECIFIC EMBODIMENTS OF THE INVENTION

Fig. 1 is a general cross-sectional view of a flat microwave antenna **8** for high frequency microwave transmission (e.g. in various parts of 0.1-40GHz range). The antenna **8** has a multilayer structure and comprises, *inter alia*, at least one PCB (Printed Circuit Board) **10** made of a dielectric material, e.g. PTFE Glass fiber type RT/duroid™ 5880 commercially available from Rogers Corporation, Arizona, USA, having relative permittivity $\epsilon_r = 2.2$. The PCB **10** has two faces, **10a** (upper face) and **10b** (lower face) on which radiating elements (not shown in Fig. 1), made of an electrically conductive material, are disposed. The antenna **8** further comprises spacer layer **12** made of a low relative permittivity (e.g. foam, typically having $\epsilon_r = 1.05$, air, having $\epsilon_r = 1.00$) and a ground plate **14**, typically made of a metallic material. Additional layers (not shown in Fig. 1) can also be used, as known in the field of antennas, such as a mounting plate, a polarizer layer, a box, etc. Discrete spacers can be used instead of spacer layer **12**. Electrical coaxial connector **16** having pin **18** and sleeve **20** is used to feed the antenna. Note that the invention is not bound by the general structure of a planar antenna as exemplified in Fig. 1. For example, antenna **10** may be a conformal antenna, which conforms to a surface whose shape is determined by considerations other than electromagnetic, for example, aerodynamic or hydrodynamic.

Fig. 2 is a top view of the upper face **10a** of the PCB **10** of the antenna **8** according to an embodiment of the invention, suitable for circular polarization. As shown in **Fig. 2** in an exemplary manner, a plurality of radiating elements **21** is disposed in a specific configuration on face **10a**. The radiating elements **21** are substantially identical and each comprises a bend-shaped element **22** and a coplanar transmission line **23** (both marked in **Fig. 2** in full lines). A plurality of substantially identical radiating elements **21** is disposed on face **10b**. Each of the radiating elements **21** disposed on face **10a** is paired with a corresponding radiating element disposed on face **10b** in a complementary manner that will be

- 7 -

discussed in detail further below. The transmission lines of the paired radiating elements substantially overlay each other (the so-called “twin line” configuration) and thus the transmission lines **23** disposed on face **10b** are not shown in Fig. 2. The bend-shaped elements **22** disposed on face **10b** are marked in dashed line. The radiating elements on both faces are disposed in a substantially symmetrical manner around the feed structures **16**, **18** and **20**. The use of “twin line” configuration as well as the symmetrical positioning of the elements around the feed structures ensures the same input impedance of all radiating elements and balanced distribution of energy throughout the array.

In the non-limiting example of **Fig. 2**, the antenna comprises an array of 8x8 pairs of radiating elements. Note that the invention is not limited by this specific example and many other array configurations are possible, as the case may be and typically, the number of pairs of radiating elements is set to provide a certain desired gain. Note that the present invention can be embodied by utilizing only one pair of radiating elements. Also, note that the invention is not bound by the specific layout and configuration of the radiating elements as exemplified in Fig. 2.

Figs. 3a-3b illustrate schematically in greater detail the structure of paired radiating elements **21** of the antenna of Fig. 2, suitable for circular polarization in the frequency range of 8-9GHz, from top and side views, respectively. Same elements are given same reference numbers. As shown in **Fig. 3a**, each of the radiating elements **21** comprises a bend-shaped element **22** connected to a transmission line **23** via feed point **25**. As will be explained in greater detail further below, each of the radiating elements **21** is designed to be capable of radiating electromagnetic waves of a circular polarization, and the paired elements **21** are aligned with respect to each other in a relatively compact spatial arrangement, in a predefined manner, such that high level of antenna performance, e.g. gain up to 3dB, is achieved, comparing to a prior art antenna with the same number of radiating elements having substantially the same geometrical dimensions. Thus, each pair of the substantially identical upper and

- 8 -

lower radiating elements disposed on the upper and lower faces yields gain increase in the range of 1dB to 3dB and provides gain in the range of 6dB to 9dB and more (this is demonstrated e.g. in Fig. 5a).

The following is a description of the design of a single radiating element in the circular polarization configuration, in accordance with an embodiment of the invention. In the following example, the PCB material is having relative permittivity $\epsilon_r = 2.2$ and width $w = 0.5\text{mm}$. Note that the invention is not bound by the following example.

As demonstrated in the non-limiting example of **Fig. 3a**, the antenna operates in a frequency of 8GHz (this being the desired operating center frequency) and an L-shaped element **22** is used, having orthogonal branches X and Y disposed on the plane of the PCB **10**. The geometrical dimensions of the L-shaped branches are as follows:

The lengths **A** and **B** of the X and Y branches are substantially identical and are defined by the following equation:

$$[1] \quad A, B = K_1 \lambda_0$$

Wherein K_1 is in the range of 0.3 to 0.35, e.g. $K_1=0.33$, and wherein λ_0 is the wavelength of the operating frequency in air. Thus, in the above mentioned operating frequency (8GHz), **A** and **B** equal 12.5mm.

The width **C** of the X and Y branches is defined as follows:

$$[2] \quad C = K_2 \lambda_0$$

Wherein K_2 is in the range of 0.10 to 0.20, e.g. $K_2=0.106$. In the example of **Fig. 3a** (operating frequency of 8 GHz), **C** equals 4mm.

The feed point **25** is connected to one of the branches, the Y branch in the example of Fig. 3a. The location of the connection determines the delay between the current components propagating along the X and Y branches and is set to generate a phase delay of 90° between the components in order to provide circular polarization.

It should be noted that the invention is not limited by the specific example of the radiating element **21** as shown in **Fig. 3a**, and many others are possible, for

- 9 -

example the elements illustrated in **Figs. 4a-4b**, each having a substantial bend-shape. Note that the shape of the bend-shaped elements need not have straight-line contour, and any version of bend-shape element can be used, including a smooth shape.

According to an embodiment of the present invention, the radiating element is configured for generating electromagnetic field with circular polarization and for that purpose it has a substantially L-shape with first and second branches and a feed point located on said second branch, such that the electric current generated in the second branch is phase delayed in 90° with respect to the electric current generated in the first branch.

Having describing the design of a single radiating element there follows a description of the design of a paired radiating element in the circular polarization configuration, according to an embodiment of the invention:

As mentioned before, the paired elements **21** disposed on both the upper and lower faces of the PCB **10** are oppositely aligned in a relatively compact space, in a complementary manner, such that the phase centers of the upper and lower elements substantially coincide, yielding high level of antenna performance. According to an embodiment of the invention, the upper and lower elements are oppositely and adjacently aligned in the following manner:

Length **D** between the X branch of said upper radiating element and the X branch of said lower radiating element, and the length **E** between the Y branch of said upper radiating element and the Y branch of said lower radiating element, are defined by the following equations:

$$[3] D = K_3 \lambda_0$$

$$[4] E = K_4 \lambda_0$$

wherein K_3 and K_4 are in the range of 0.3 to 0.6, e.g. K_3 equals $0.57 \lambda_0$ and K_4 equals $0.41 \lambda_0$. Note that **D** and **E** need not be identical. Also note that upper and lower radiating elements need not be in full symmetry with each other. Note that **D** and **E** values other than the above specified values can be used. For example, in the case **D** or **E** exceeds $0.6 \lambda_0$, the gain of the antenna may increase

- 10 -

due to the increase in the equivalent surface of the antenna. However the axial ratio (the measure of the antenna circularity on its axis of symmetry) is increased.

According to the present invention and as illustrated in **Figs. 2** and **3a**, the phase centers of the upper and lower radiating elements substantially coincide with each other. In the case the paired elements are arranged in an array (as shown in **Fig. 2**), a length **F** between the phase centers of adjacent pairs must be kept at a certain range as follows:

$$[5] 0.5 \lambda_0 < F < 1 \lambda_0$$

In the above discussion with reference to **Figs. 2** and **3a-3b**, the relative alignment of the paired elements **21** is presented in two dimensions only, namely with respect to the X and Y axis that define the plane of the PCB **10**. However, the relative alignment of the paired element **21** is actually defined in three-dimensions, i.e. onto the plane of the PCB **10** and also along the orthogonal Z axis. Due to the very small width **w** of the PCB **10** (as shown in **Fig. 3b**), typically about 0.1-0.5mm, it is possible to disregard the relative alignment considerations along the Z axis and to define the relative alignment of the paired elements in two-dimensions only. The width **w** of the PCB **10** needs to be very small with respect to λ , the wavelength corresponding to the operating frequency of the antenna, e.g. less than 0.05λ or 0.1λ or more, otherwise the relative alignment of the paired element should be defined in three dimensions.

The phase center of an antenna can be determined by measurements, computed simulations, and calculations. As discussed in "Antenna Handbook, Volume II Antenna Theory", ed. Y. T. Lo, Van Nostrand Reinhold, New York, in chapter 8, the analytical formulations for locating the phase center of an antenna typically exist for only a limited number of antenna configurations. Experimental techniques are known in the art for locating the phase center of an antenna, as well as simulation tools such as the CST Microwave Studio™ software commercially available from CST Computer Simulation Technology GmbH, Germany.

Figs. 5a-5e illustrate simulated characteristics of a pair of radiating elements according to an embodiment of the invention, in the circular polarization configuration shown in Fig 3a, relating to operating frequencies in the range of 8-9GHz, as follows.

Fig. 5a shows the gain of a single pair of radiating elements. Note that typically the characterizing gain of a prior art radiating elements having substantially the same geometrical dimensions as described above with reference to Fig. 3a is substantially up to 6dB. **Fig. 5b** shows the simulated radiation pattern of the pair of radiating elements. Graph **A** represents the component E_{ϕ} for $\phi = 0^\circ$ and graph **B** represents the component E_{θ} for $\phi = 0^\circ$. **Fig. 5c** shows the return loss in dB (the so-called S_{11}). **Fig. 5d** shows the axial ratio at $(0,0)^\circ$ (the so-called Broad side direction). **Fig. 5e** shows the so-called "Smith chart" of the input impedance.

According to yet another embodiment of the invention there is provided an antenna suitable for linear polarization. There follows a description of the design of a single radiating element as well as the paired radiating elements in the linear polarization configuration.

Reference is now made to **Fig. 6**, illustrating the structure of paired radiating elements **35** of an antenna according to an embodiment of the invention suited for linear polarization (horizontal or vertical, as the case may be) in operating frequency of 8GHz. In the case of linear polarization, each of the upper and lower radiating elements **36** has bend-shaped elements having the shape of two-branches creating an acute angle between the branches. According to an embodiment of the invention the upper and lower radiating elements are relatively aligned such that the shape "Z" or "S" (or substantially such shape) is created, as shown in **Fig. 6**.

According to an embodiment of the invention, the radiating elements of the linear polarization configuration comprises bend-shaped elements having first and second branches arranged in an acute angle with respect to each other. The upper and lower radiating elements are arranged in a substantially symmetrical

- 12 -

arrangement on both faces of the PCB, such that the first branches of the upper and lower elements are in parallel; and the electrical length of each of said first branches is about $0.5\lambda_0$, wherein λ_0 is the wavelength of said predefined frequency in air. In other words, each of the first branches of the upper and lower radiating elements, by itself, operates as a radiating element in linear polarization.

In the following example, the PCB material is having relative permittivity $\epsilon_r = 2.2$ and width $w = 0.5\text{mm}$. Note that the invention is not bound by the following example. The geometrical dimensions of the acute-angled branches according to the following example are as follows:

The length **G** of the first branch is defined by the following equation:

$$[7] \quad G = K_5 \lambda_0$$

Wherein K_5 is in the range of 0.3 to 0.4, e.g. $K_5=0.36$, and wherein λ_0 is the wavelength of the operating frequency in air. Thus, in the above-mentioned example (operating frequency of 8GHz), **G** equals 13.5mm.

The length **H** between the first branches of the upper and lower elements is defined by the following equation:

$$[8] \quad H = K_6 \lambda_0$$

Wherein K_6 is in the range of 0.3 to 0.35, e.g. $K_6=0.32$, and wherein λ_0 is the wavelength of the operating frequency in air. Thus, in the above mentioned operating frequency (8GHz), **H** equals 12mm.

The width **I** of the radiating element is defined by the following equation:

$$[9] \quad I = K_7 \lambda_0$$

Wherein K_7 is in the range of 0.015 to 0.025, e.g. $K_7=0.02$, and wherein λ_0 is the wavelength of the operating frequency in air. Thus, in the above-mentioned operating frequency (8GHz), **I** equals 1mm. note that the invention is not limited by the specific example of Fig. 6.

Figs. 7a-7c illustrate simulated characteristics of an antenna paired element according to the embodiment of the invention shown in **Fig. 6**, in the operating frequency range of 8-9GHz, as follows. **Fig. 7a** shows simulated input

- 13 -

impedance of one paired element (the so called "Smith chart"). **Fig. 7b** shows the return loss in dB (the so-called S_{11}), of one paired element, in the frequency range of 8-9GHz, and **Fig. 7c** shows the polar elevation pattern of the paired element at the frequency of 8.2GHz. Graph **A** represents the component E_{θ} for $\phi = 90^\circ$ and graph **B** represents the component E_{ϕ} for $\phi = 0^\circ$.

According to yet another embodiment of the invention, a polarizer is added to the antenna of the invention working in circular polarization (e.g. shown in Fig. 2), thereby transforming it to work in linear polarization (note that by adding a polarizer to an antenna working in linear polarization, a transformation to work in circular polarization is achieved). As shown in Fig. 8, a polarizing layer **P** (a polarizer) is added to one side (e.g. the upper side) of a planer antenna of the kind described above with reference to Figs. 3A and 3B (same numerals are used, referring to same elements). The polarizer is designed to cover substantially the entire upper surface of the antenna (in the xy plane shown in Figs. 3A and 3B). The thickness of the polarizer has a typical value between 2cm and 3cm.

Using the above detailed design, such that the antenna described above with reference to Figs. 3A and 3B entirely covered on top with a polarizer P, has substantially no effect on the adaptation of the antenna. In the frequency range of 8 to 9 GHz, the return loss is substantially similar to the one shown in Fig. 5C. The measured pattern of the antenna exhibits a ratio of under -15dB between the main and the cross polarization, along the frequency band. This means that a substantially correct transformation of the circular polarization to linear polarization is obtained. The measured gain of a single element (radiating element **21** shown e.g. in Fig. 3A, or other element e.g. as shown in Figs. 4A-4D) present a gain of 8dBi and more.

Referring now to **Figs. 9a-9b**, there is presented, according to another embodiment of the invention, an antenna that combines right-hand and left-hand circular polarization over the same area. Antenna **900** comprises PCB **910**, which is of the kind described hereinbefore (e.g. element **10** shown in Figs. 1, 2 and 3a).

- 14 -

PCB **910** has two faces, **910a** (upper face) and **910b** (lower face), on which radiating elements of the present invention (e.g. elements **21** shown in **Fig. 3a**) are disposed, providing, as an example, right-hand circular polarization. PCB **920** which is identical to PCB **910** and is rotated by 180° to mirror PCB **910** (rotated with respect to axis Y shown in Figs. 3a and 3b) providing left-hand circular polarization. The resultant multi-layered structure is illustrated in **Fig. 9b**, in which each layer and each face are pointed by an arrow, in a self-explanatory manner.

The radiating elements are spaced apart onto PCBs **910** and **920** and PCB **920** is somewhat shifted with respect to PCB **910** (shift **S** shown in **Fig. 9a**, allowing radiating elements from one PCB to be located above non radiating portions of the other PCB), such that destructive influence between elements of different layers (PCB **910**, PCB **920**) is prevented. The arrangement of the elements is defined by the following equation:

$$[10] \quad M = K_8 \lambda_0$$

wherein K_8 is in the range of 0.8 – 1.0. Note that **M** defines the distance between the phase centers of adjacent paired elements on top of the same PCB. PCB **910** and **920** are spaced apart from one another by a small distance, e.g. $0.1\lambda_0$, providing a thin air layer for isolation therebetween. This embodiment of the invention allows using two identical printed antenna boards in combination, in an efficient manner, to provide over the same area right-hand or left-hand circular polarization, or both, as required. It should be noted that according to the present invention as described above, the radiation pattern of each of the radiating elements (elements **21** as illustrated in **Fig. 3a**) is equilibrated, due to the phase centers of the upper and lower elements being superposing, thereby yielding high gain. If a different structure is used, in which the arms of the upper and lower elements do not overlap (i.e. the phase centers do not coincide), the resultant radiation pattern is dis-equilibrated, yielding relatively low gain. Therefore, in order to better the performance of such a structure, the elements

- 15 -

need to be aligned such that mutual coupling between adjacent elements will not provide distractive influence.

The invention was described in details with reference to a planar configuration, in which the radiating elements are disposed onto both faces of a planar support. It should be noted that the invention is not limited by the above-described planar configuration and other arrangements are possible within the scope of the invention. For example, the invention can be implemented as a conformal antenna, which conforms to a surface whose shape is determined by considerations other than electromagnetic, for example, aerodynamic or hydrodynamic, or other non-planar configurations.

The invention was described in detail with reference to the operating frequencies falling within the range of 8-9GHz. It should be noted that the invention is not limited by this specific example, and is suitable to operate in a variety of frequencies, with the necessary modifications and alterations, e.g. change of the operating frequency would result in change in the geometrical dimensions of the radiating elements and their respective planar layout and arrangement. The invention was described with reference to a printed configuration (utilizing a PCB), however it should be noted that the invention is not limited by this configuration. It should also be noted that in the range of relatively lower frequencies (e.g. 1GHz and less), λ equals 30cm or more, thus allowing the use radiating elements made of metal, as well as the use of air spacers, foam layers, etc.

The invention was described with reference to a single PCB configuration, in which the PCB has the radiating elements disposed on both its faces. It should be noted that the invention can be implemented in another configuration, in which two PCBs and more are adjacently used, each having the radiating elements disposed on one or both its faces, such that the phase centers of adjacent radiating elements substantially coincide.

The present invention has been described with a certain degree of particularity, but those versed in the art will readily appreciate that various

- 16 -

alterations and modifications may be carried out without departing from the scope of the following Claims:

CLAIMS:

1. A microwave antenna for transmitting and/or receiving electromagnetic waves of at least one predefined frequency and a predefined polarization, the antenna comprising a support with upper and lower faces; at least one pair of substantially identical upper and lower radiating elements disposed on said upper and lower faces; in each pair of said radiating element in the upper face and the corresponding radiating element in the lower face, the phase center of the lower radiating element substantially coincides with the phase center of the upper radiating element.
2. An antenna according to Claim 1 wherein said support is conformal.
3. An antenna according to Claim 1 or 2 wherein said support is substantially planar.
4. An antenna according to any one of Claims 1 to 3 wherein said predefined polarization is a circular polarization, and wherein each of said radiating elements is capable of radiating electromagnetic waves of a circular polarization.
5. An antenna according to Claim 4 wherein said radiating elements comprising bend-shaped elements.
6. An antenna according to Claim 4 wherein said bend-shape is an L-shape.
7. An antenna according to Claim 6 wherein said L-shape having first and second branches and a feed point located on said second branch such that the electric current generated in the second branch is phase delayed in 90° with respect to the electric current generated in the first branch.
8. An antenna according to Claim 7 wherein said L-shape having an X branch and an orthogonal Y branch, and wherein:
 - the length A of the X branch and the length B of the Y branch are substantially identical and depend on said predefined frequency according to the relation: $A, B = K_1 \lambda_0$, K_1 is in the range of 0.3 to 0.35;

- 18 -

- the widths C of the X and Y branches depend on said predefined frequency according to the relation: $C = K_2 \lambda_0$, K_2 is in the range of 0.10 to 0.20;
- the length D between the X branch of said upper radiating element and the X branch of said lower radiating element depend on said predefined frequency according to the relation: $D = K_3 \lambda_0$, K_3 is in the range of 0.3 to 0.6;
- the length E between the Y branch of said upper radiating element and the Y branch of said lower radiating element depend on said predefined frequency according to the relation: $E = K_4 \lambda_0$, K_4 is in the range of 0.3 to 0.6;

wherein λ_0 is the wavelength of said predefined frequency in air.

9. An antenna according to any one of Claims 1 to 3 wherein said predefined polarization is a linear polarization.

10. An antenna according to Claim 9 wherein said radiating elements comprising radiating elements having first and second branches arranged in an acute angle with respect to each other.

11. An antenna according to Claim 10 wherein:

- said upper and lower radiating elements are symmetrically arranged such that the first branches of the upper and lower elements are in parallel; and
- the electrical length of said first branch is $0.5\lambda_0$, wherein λ_0 is the wavelength of said predefined frequency in air.

12. An antenna according to any one of Claims 1 to 3 wherein said pair of substantially identical upper and lower radiating elements disposed on said upper and lower faces yields gain increase in the range of 1dB-3dB.

13. An antenna for transmitting and/or receiving electromagnetic waves of at least one predefined frequency and a predefined polarization, the antenna comprising a multi-layered substrate structure having a dielectric substrate with upper and lower faces; at least one pair of substantially identical upper and lower

- 19 -

radiating elements disposed on said upper and lower faces of the dielectric substrate; each radiating element transmitting and/or receiving electromagnetic waves with a phase center located at a predefined position; each radiating element comprising a radiating element and a transmission line, the geometrical dimensions of which depend on said predefined frequency; in each pair of said radiating element in the upper face and the corresponding radiating element in the lower face:

- the transmission lines of the upper and lower elements overlay each other;
- the radiating elements of the upper and lower elements are located oppositely to each other with respect to a plane perpendicular to the plane of the dielectric substrate, such that the phase center of the lower radiating element substantially coincides with the phase center of the upper radiating element.

14. An antenna according to Claim 13 wherein said multi-layered substrate structure is conformal.

15. An antenna according to Claim 1 wherein said multi-layered substrate structure is substantially planar.

16. An antenna according to any one of Claims 13 to 15 wherein said predefined polarization is a circular polarization, and wherein each of said radiating elements is capable of radiating electromagnetic waves of a circular polarization.

17. An antenna according to Claim 16 wherein said radiating elements comprising radiating elements having a substantial L-shape.

18. An antenna according to Claim 16 wherein said radiating elements comprising radiating elements having an L-shape.

19. An antenna according to Claim 18 wherein said L-shape having first and second branches and a feed point located on said second branch such that the electric current generated in the second branch is phase delayed at 90° with respect to the electric current generated in the first branch.

- 20 -

20. An antenna according to any one of Claims 13 to 15 wherein said predefined polarization is a linear polarization.

21. An antenna according to Claim 20 wherein said radiating elements comprising radiating elements having first and second branches arranged in an acute angle with respect to each other.

22. An antenna according to Claim 21 wherein:

- said upper and lower radiating elements are symmetrically arranged such that the first branches of the upper and lower elements are in parallel; and
- the electrical length of said first branch is $0.5\lambda_0$, wherein λ_0 is the wavelength of said predefined frequency in air.

23. An antenna according to any one of Claims 13 to 15 wherein said pair of substantially identical upper and lower radiating elements disposed on said upper and lower faces yields gain increase in the range of 1dB-3dB.

24. A method for providing a planar antenna for transmitting and/or receiving electromagnetic waves of at least one predefined frequency and a predefined polarization, the antenna having a dielectric substrate with upper and lower faces; at least one pair of substantially identical upper and lower radiating elements disposed on said upper and lower faces of the dielectric substrate; said radiating elements comprising radiating elements having first and second branches, the method comprising:

- determining a planar arrangement and geometrical dimensions of said first and second branches in accordance with said predefined polarization and said at least one predefined frequency;
- associating each of the radiating elements in the upper face with a corresponding radiating element in the lower face, such that the phase center of the lower radiating element substantially coincides with the phase center of the upper radiating element.

25. A method according to Claim 24 wherein said predefined polarization is a circular polarization and wherein each of said radiating elements is capable of radiating electromagnetic waves of a circular polarization.

26. A method according to Claim 25 wherein said radiating elements comprise radiating elements having a bend-shape.

27. A method according to Claim 26 wherein said bend-shape is an L-shape.

28. A method according to Claim 27 wherein said L-shape having first and second branches and a feed point located on said second branch such that the electric current generated in the second branch is phase delayed at 90° with respect to the electric current generated in the first branch.

29. A method according to Claim 27 wherein said L-shape having an X branch and an orthogonal Y branch, and wherein:

- the length A of the X branch and the length B of the Y branch are substantially identical and depend on said predefined frequency according to the relation: $A, B = K_1 \lambda_0$, K_1 is in the range of 0.3 to 0.35;
- the widths C of the X and Y branches depend on said predefined frequency according to the relation: $C = K_2 \lambda_0$, K_2 is in the range of 0.10 to 0.20;
- the length D between the X branch of said upper radiating element and the X branch of said lower radiating element depend on said predefined frequency according to the relation: $D = K_3 \lambda_0$, K_3 is in the range of 0.3 to 0.6;
- the length E between the Y branch of said upper radiating element and the Y branch of said lower radiating element depend on said predefined frequency according to the relation: $E = K_4 \lambda_0$, K_4 is in the range of 0.3 to 0.6;

wherein λ_0 is the wavelength of said predefined frequency in air.

30. A method according to Claim 24 wherein said predefined polarization is a linear polarization.

- 22 -

31. A method according to Claim 30 wherein said radiating elements comprise radiating elements having first and second branches arranged in an acute angle with respect to each other.

32. A method according to Claim 31 wherein:

- said upper and lower radiating elements are symmetrically arranged such that the first branches of the upper and lower elements are in parallel; and
- the electrical length of said first branch is $0.5\lambda_0$, wherein λ_0 is the wavelength of said predefined frequency in air.

33. The antenna according to any one of Claims 1 to 23, further comprising a polarizer mounted on top of the upper face of said support such that substantially all radiating elements disposed on said support are covered by the polarizer, thereby allowing transformation between linear and circular polarization.

34. The antenna according to any one of Claims 1 to 8, 12 to 19 and 23, wherein the phase centers of adjacent pairs of radiating elements are distant no less than $0.8\lambda_0$, λ_0 is the wavelength of said predefined frequency in air; said support constituting a first support and said antenna further comprising a second support, substantially identical to said first support; the second support is rotated by 180° with respect to the first support and shifted such that radiating elements disposed on said second support are located above non-radiating portions of the first support, thereby providing over the same area right-hand and left-hand circular polarization.

35. A method according to any one of Claims 24 to 32, further comprising:

- covering substantially each of the radiating elements in the upper face with a polarizer, thereby allowing transformation between linear and circular polarization.

36. A method according to any one of Claims 24 to 29 wherein the phase centers of adjacent pairs of radiating elements are distant no less than $0.8\lambda_0$, λ_0 is the wavelength of said predefined frequency in air; said antenna having a second support, substantially identical to said dielectric support; the second support is

- 23 -

rotated by 180° with respect to the dielectric support and shifted such that radiating elements disposed on said second support are located above non-radiating portions of the first support, thereby providing over the same area right-hand and left-hand circular polarization.

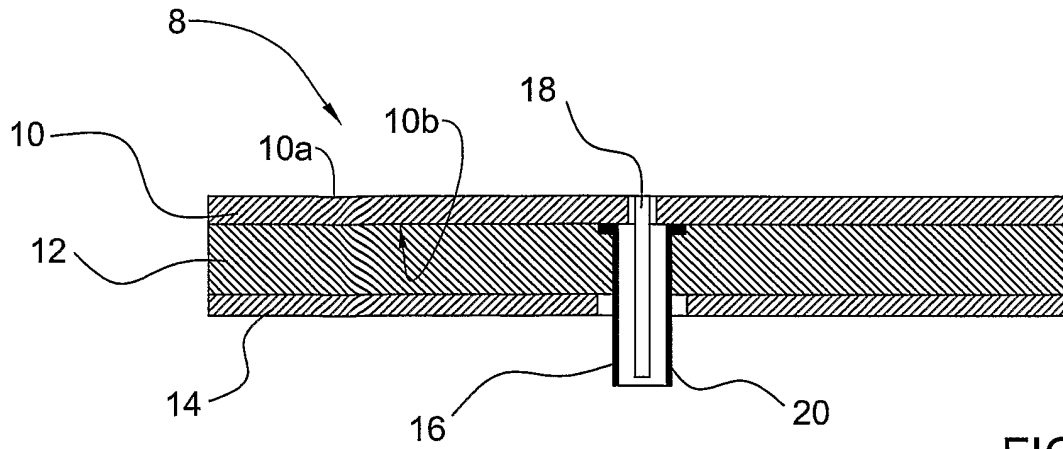

FIG. 1

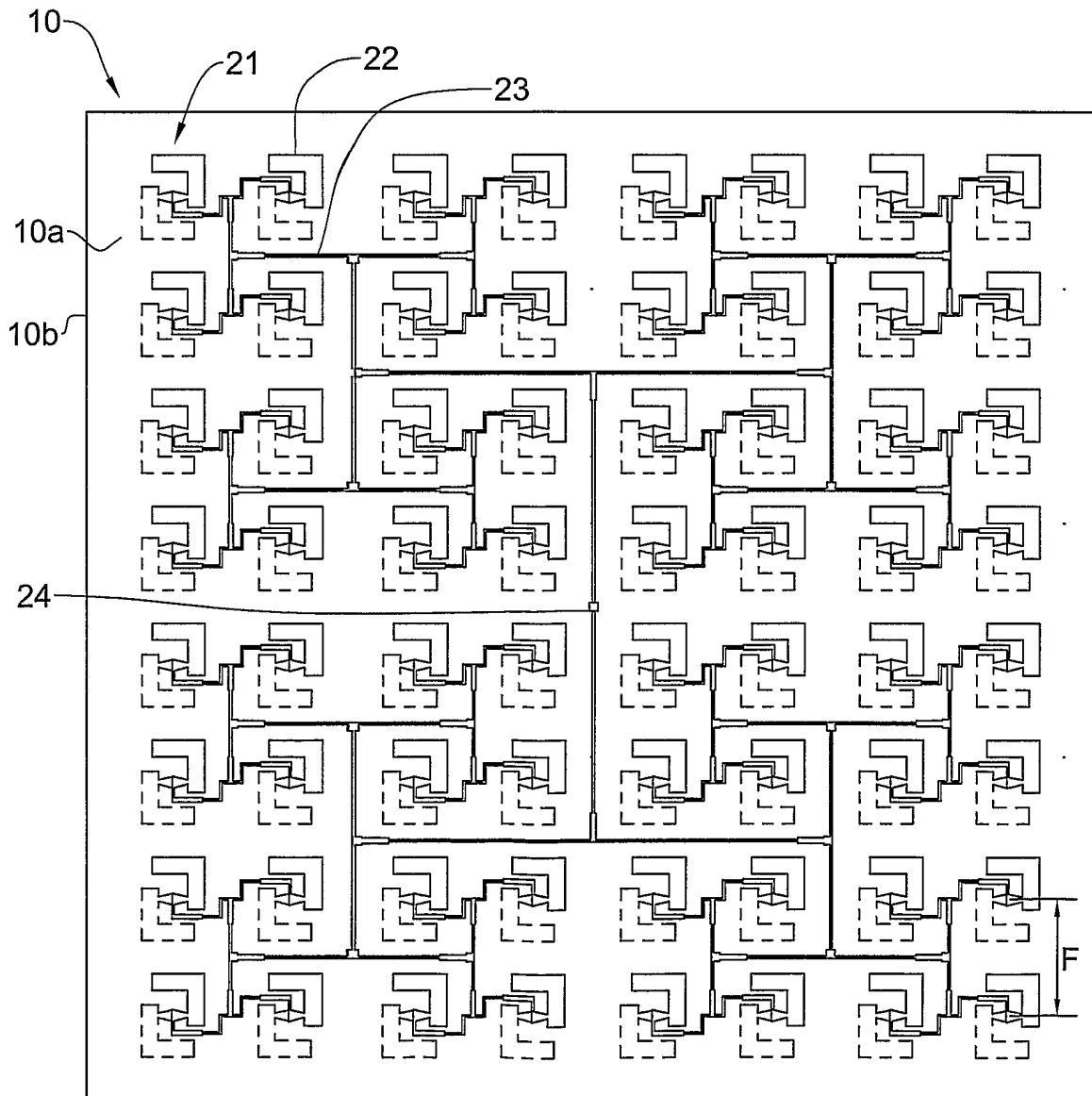

FIG. 2

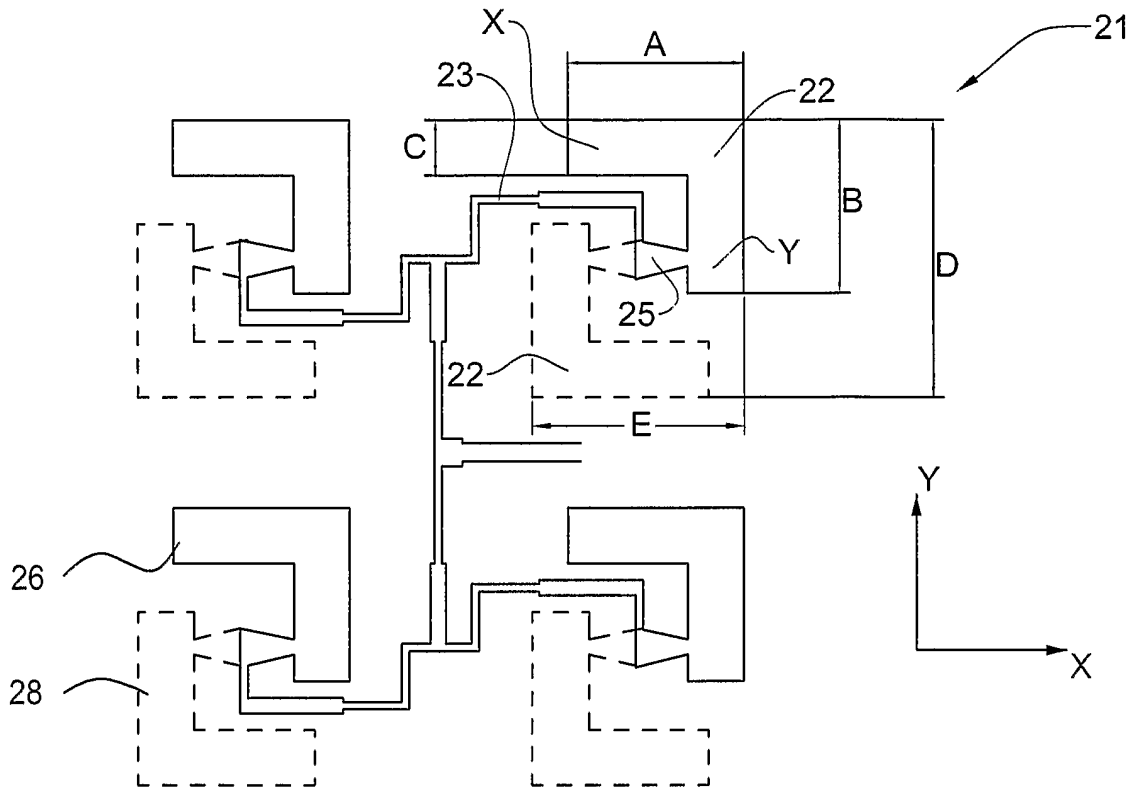

FIG. 3A

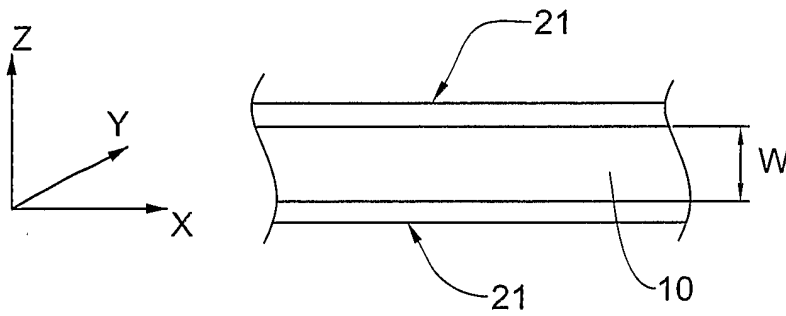

FIG. 3B

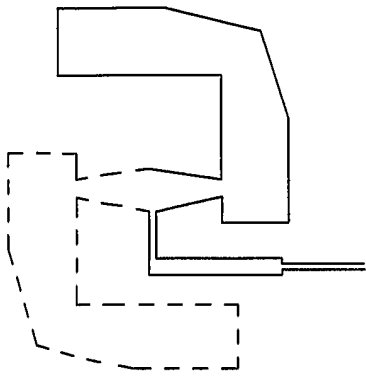

FIG. 4A

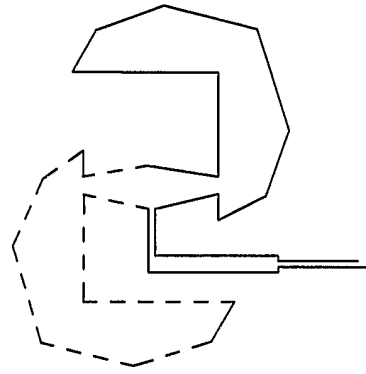

FIG. 4B

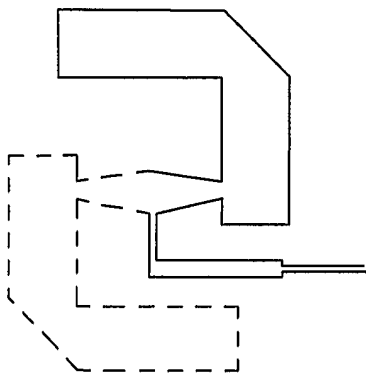

FIG. 4C

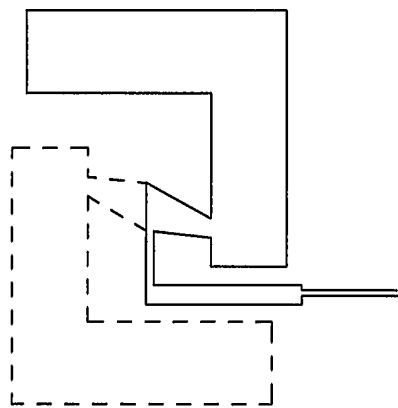

FIG. 4D

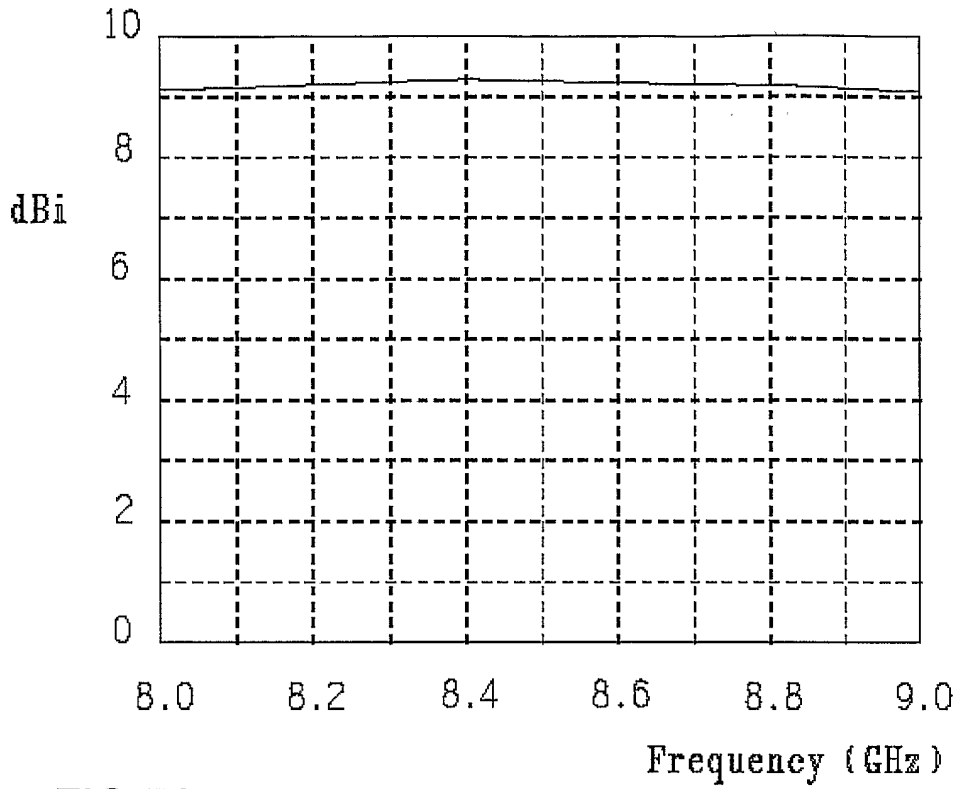

FIG.5A

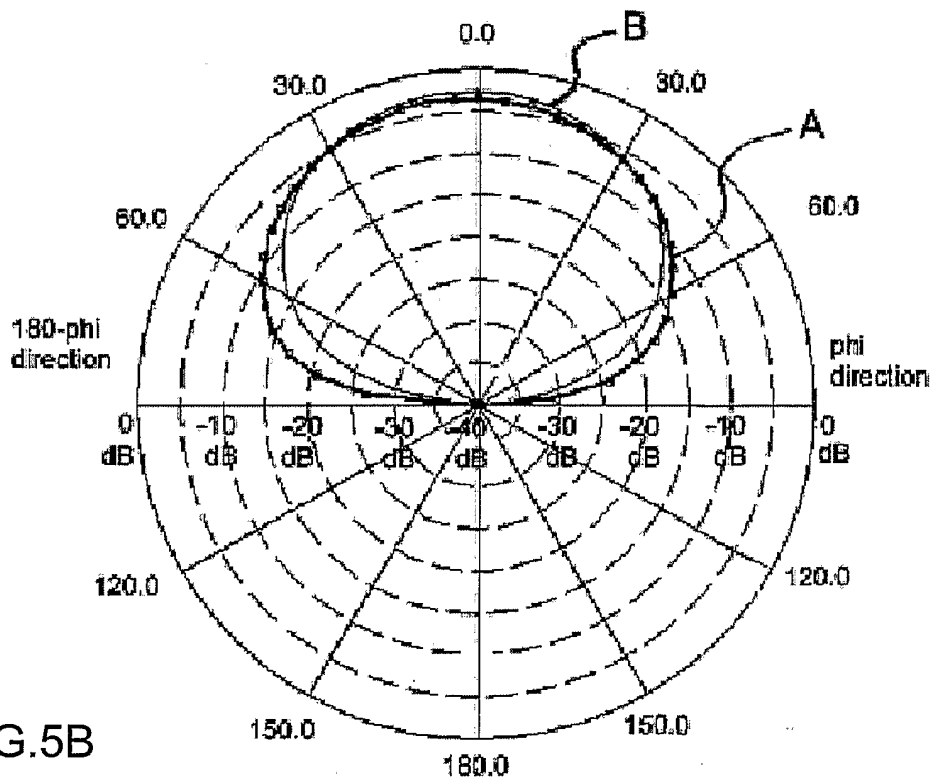

FIG.5B

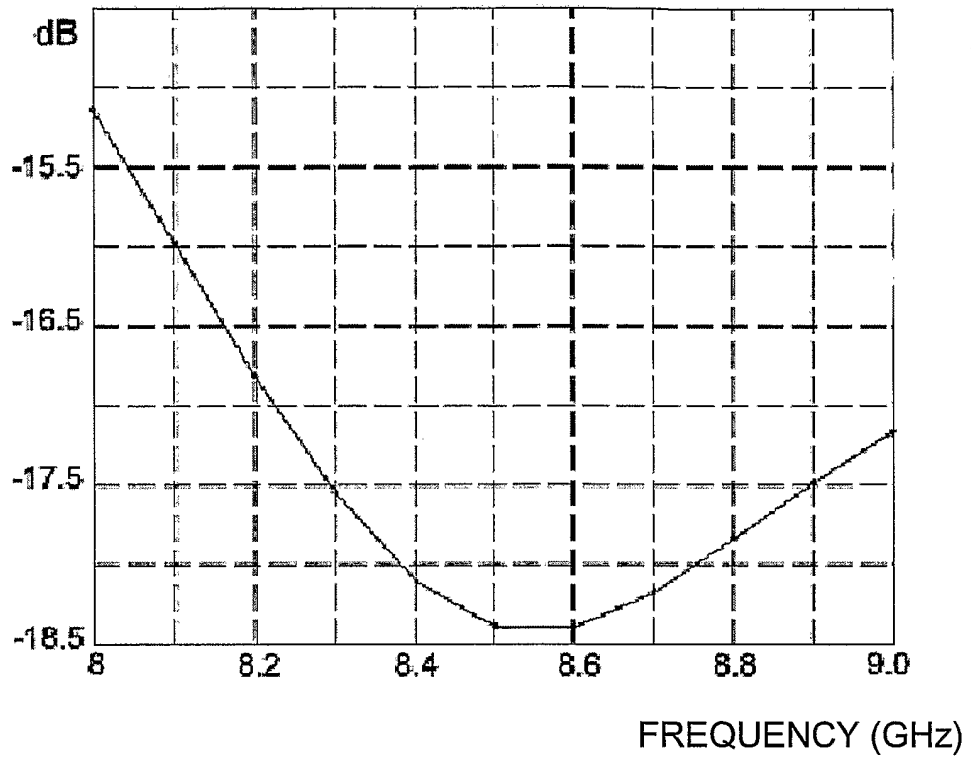

FIG.5C

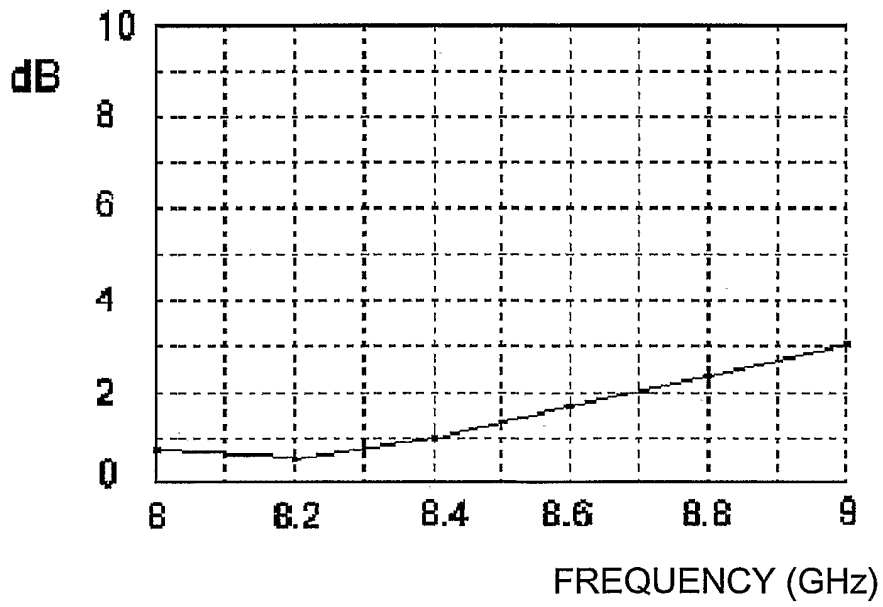

FIG.5D

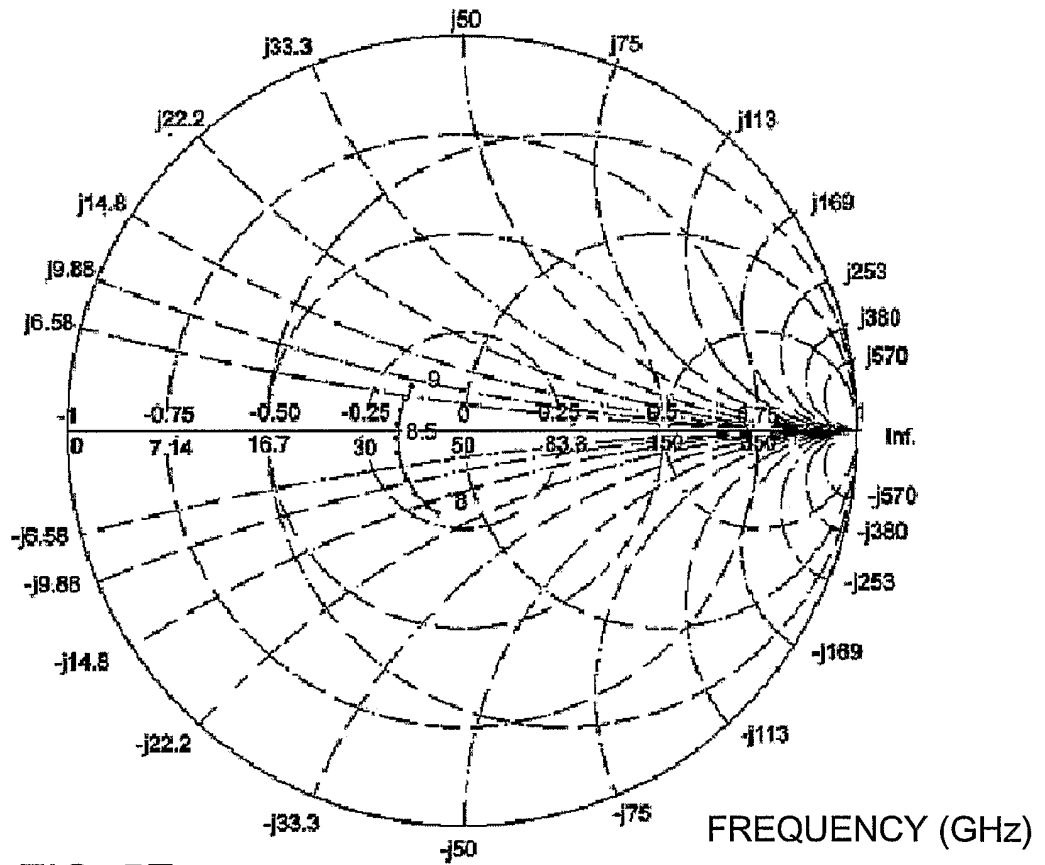

FIG. 5E

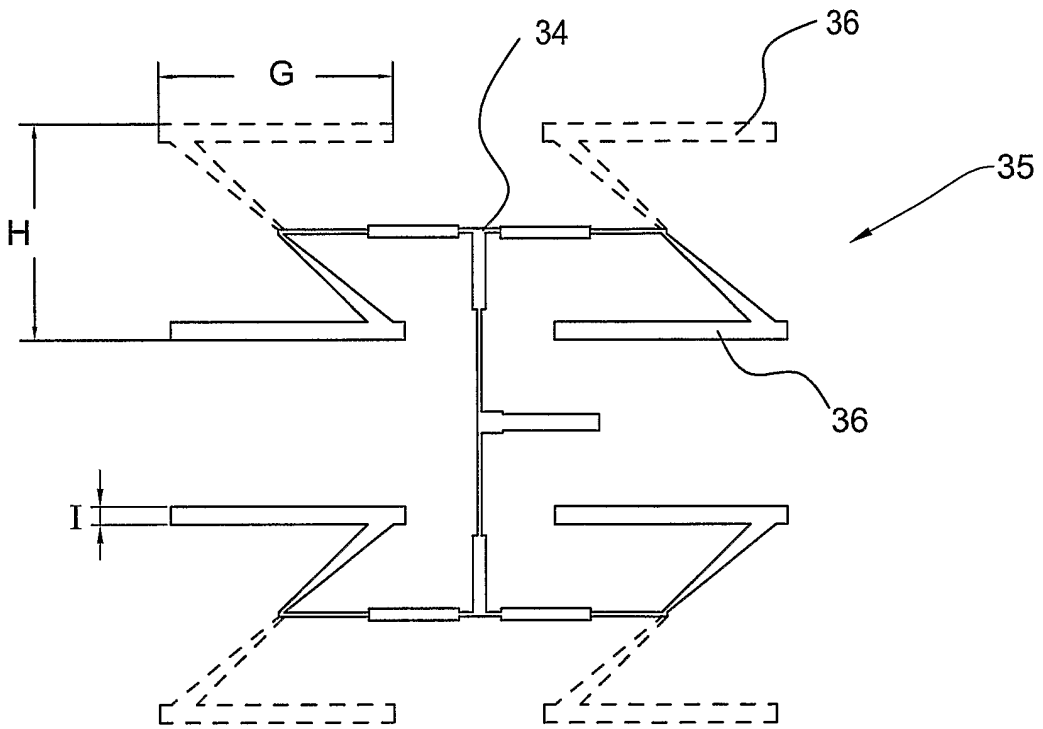

FIG. 6

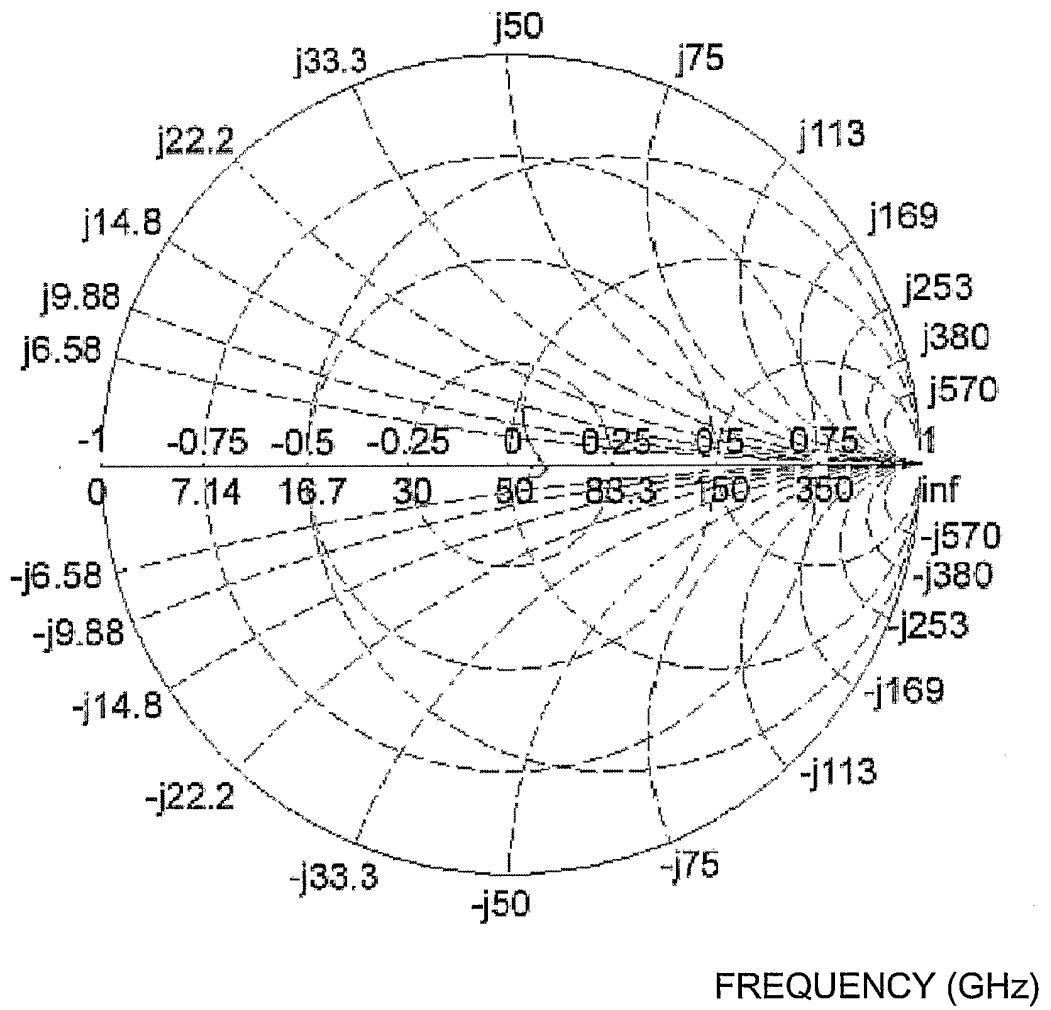

FIG. 7A

9/11

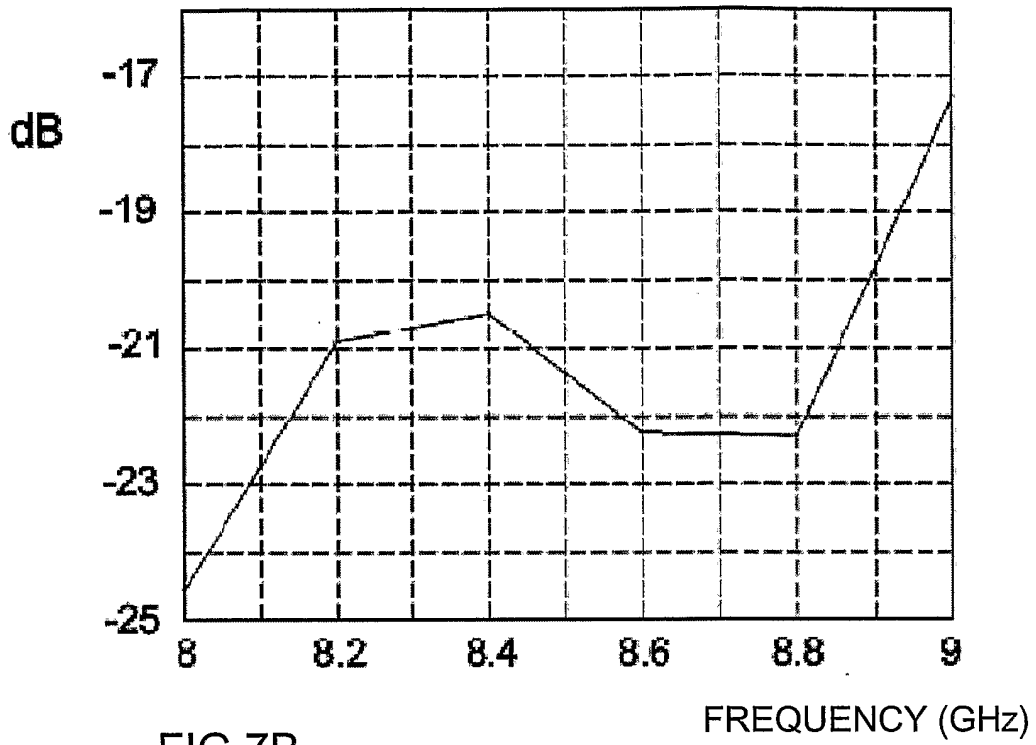

FIG.7B

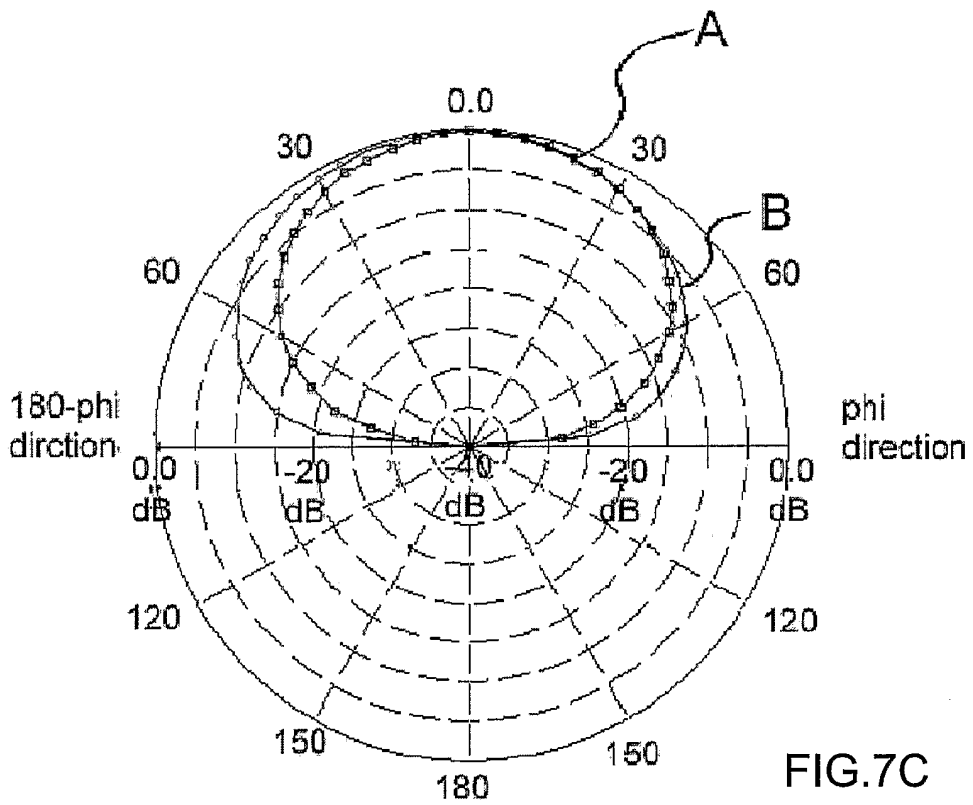

FIG.7C

10/11

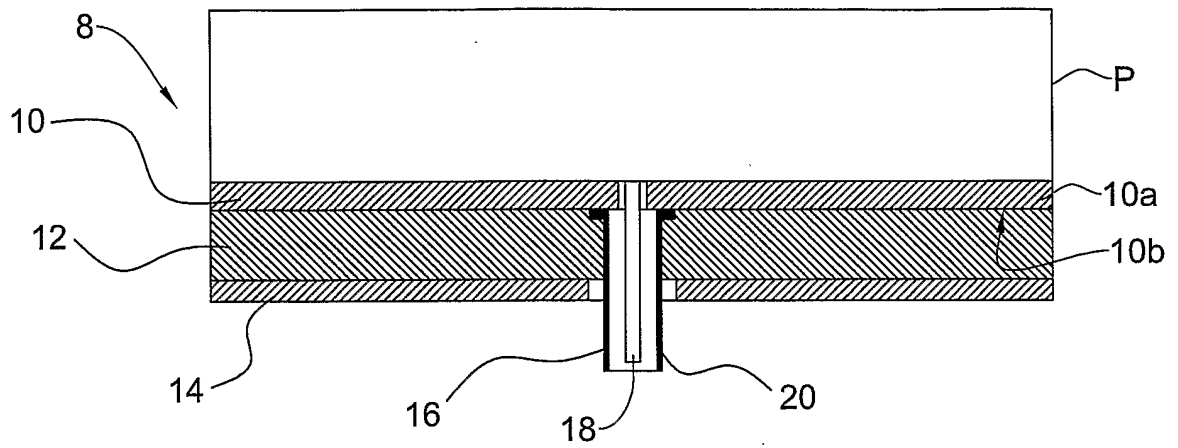

FIG. 8

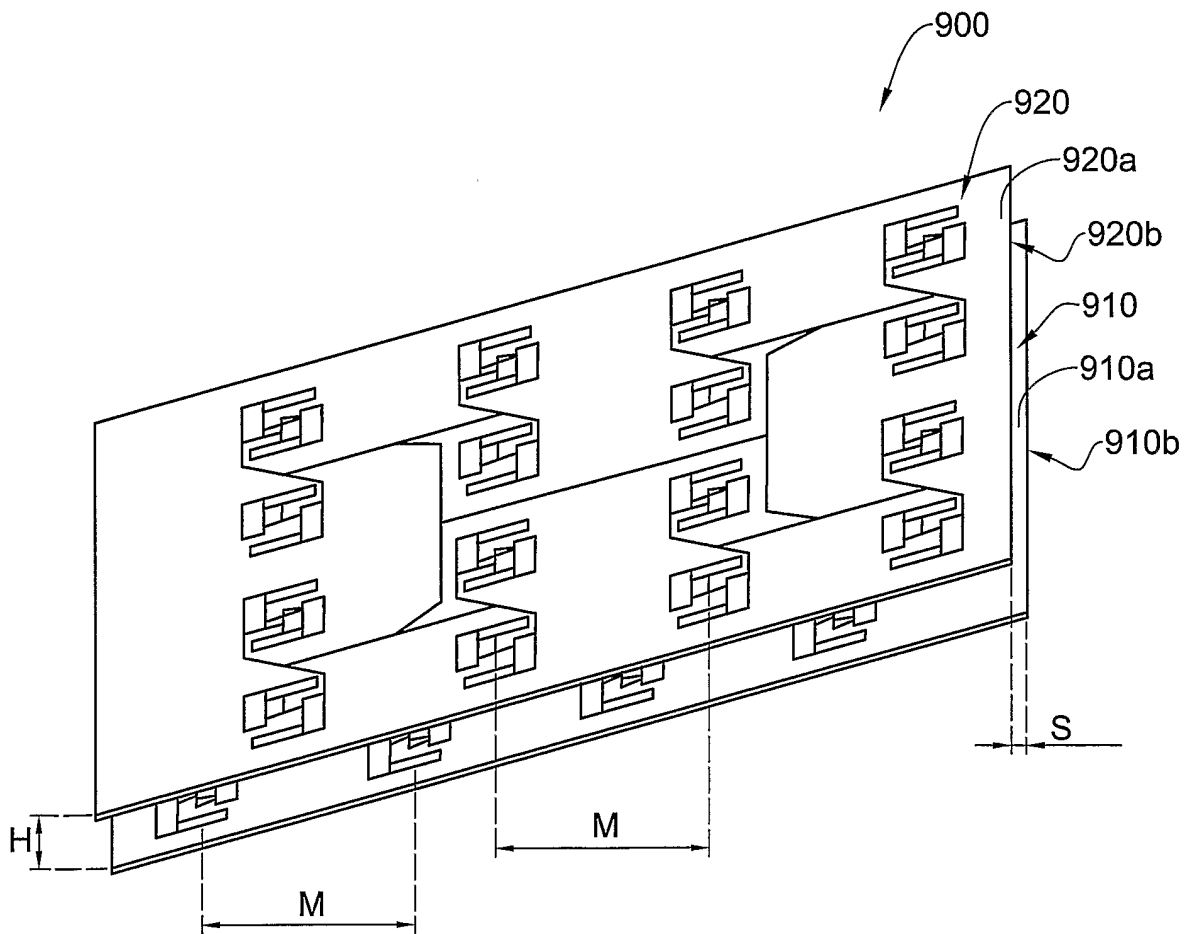

FIG. 9A

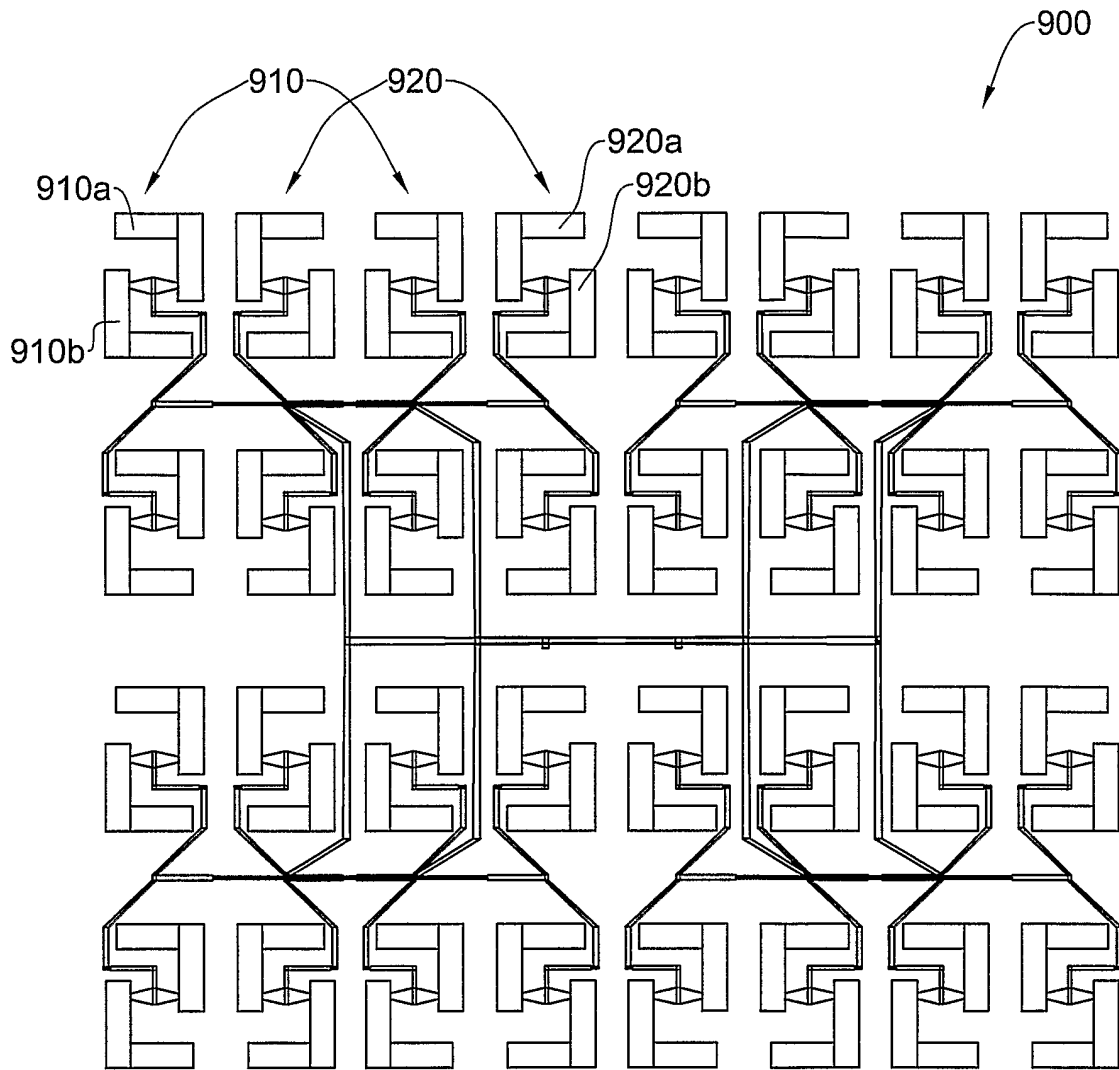

FIG. 9B

INTERNATIONAL SEARCH REPORT

International Application No
PCT/IL2005/000295

A. CLASSIFICATION OF SUBJECT MATTER IPC 7 H01Q9/04 H01Q9/26 H01Q1/38		
According to International Patent Classification (IPC) or to both national classification and IPC		
B. FIELDS SEARCHED		
Minimum documentation searched (classification system followed by classification symbols) IPC 7 H01Q		
Documentation searched other than minimum documentation to the extent that such documents are included in the fields searched		
Electronic data base consulted during the international search (name of data base and, where practical, search terms used) EPO-Internal, PAJ, WPI Data		
C. DOCUMENTS CONSIDERED TO BE RELEVANT		
Category °	Citation of document, with indication, where appropriate, of the relevant passages	Relevant to claim No.
X	EP 0 920 074 A (SONY INTERNATIONAL GMBH) 2 June 1999 (1999-06-02) paragraphs '0035!', '0036!'; figure 7	1-8, 13-19, 24-29, 34-36
X	US 6 275 192 B1 (KIM YOUNG-EIL) 14 August 2001 (2001-08-14) abstract; figure 2	1, 13, 24
X	EP 1 271 692 A (SONY INTERNATIONAL GMBH) 2 January 2003 (2003-01-02) paragraphs '0018! - '0025!'; figures 1, 2 -/--	1, 4, 13, 16, 24, 25
<input checked="" type="checkbox"/> Further documents are listed in the continuation of box C. <input checked="" type="checkbox"/> Patent family members are listed in annex.		
° Special categories of cited documents :		
A document defining the general state of the art which is not considered to be of particular relevance *E* earlier document but published on or after the international filing date *L* document which may throw doubts on priority claim(s) or which is cited to establish the publication date of another citation or other special reason (as specified) *O* document referring to an oral disclosure, use, exhibition or other means *P* document published prior to the international filing date but later than the priority date claimed *T* later document published after the international filing date or priority date and not in conflict with the application but cited to understand the principle or theory underlying the invention *X* document of particular relevance; the claimed invention cannot be considered novel or cannot be considered to involve an inventive step when the document is taken alone *Y* document of particular relevance; the claimed invention cannot be considered to involve an inventive step when the document is combined with one or more other such documents, such combination being obvious to a person skilled in the art. *&* document member of the same patent family		
Date of the actual completion of the international search 7 June 2005		Date of mailing of the international search report 14/06/2005
Name and mailing address of the ISA European Patent Office, P.B. 5818 Patentlaan 2 NL - 2280 HV Rijswijk Tel. (+31-70) 340-2040, Tx. 31 651 epo nl, Fax: (+31-70) 340-3016		Authorized officer Van Dooren, G

INTERNATIONAL SEARCH REPORT

International Application No

PCT/IL2005/000295

C.(Continuation) DOCUMENTS CONSIDERED TO BE RELEVANT

Category °	Citation of document, with indication, where appropriate, of the relevant passages	Relevant to claim No.
X	US 6 285 323 B1 (FRANK ZVI HENRY) 4 September 2001 (2001-09-04) column 5, line 23 - column 6, line 23; figure 5	1, 9-11, 13, 20-22, 24, 30-33
A	WO 01/80358 A (UNIVERSITY OF SURREY; SAUNDERS, SIMON, REZA; SUVANNAPATTANA, PANOMPORN) 25 October 2001 (2001-10-25) figure 2	10, 11, 21, 22, 31-33
X	US 6 037 911 A (BRANKOVIC ET AL) 14 March 2000 (2000-03-14) abstract; figure 2	1, 9, 13, 20, 24, 30

INTERNATIONAL SEARCH REPORT

Information on patent family members

International Application No
PCT/IL2005/000295

Patent document cited in search report	A	Publication date	Patent family member(s)	Publication date
EP 0920074	A	02-06-1999	EP 0920074 A1	02-06-1999
			JP 11243314 A	07-09-1999
			US 6339406 B1	15-01-2002
<hr/>				
US 6275192	B1	14-08-2001	CN 1326243 A , C	12-12-2001
			EP 1160916 A2	05-12-2001
			JP 3501757 B2	02-03-2004
			JP 2001345622 A	14-12-2001
			SG 88810 A1	21-05-2002
			TW 469668 B	21-12-2001
<hr/>				
EP 1271692	A	02-01-2003	EP 1271692 A1	02-01-2003
			DE 60102574 D1	06-05-2004
			DE 60102574 T2	03-02-2005
			JP 2003051707 A	21-02-2003
			US 2003006938 A1	09-01-2003
<hr/>				
US 6285323	B1	04-09-2001	IL 121978 A	12-05-2004
			CA 2250292 A1	14-04-1999
			EP 0910134 A2	21-04-1999
			US 6023243 A	08-02-2000
<hr/>				
WO 0180358	A	25-10-2001	AU 9335601 A	30-10-2001
			WO 0180358 A1	25-10-2001
<hr/>				
US 6037911	A	14-03-2000	EP 0889542 A1	07-01-1999
			EP 0889543 A1	07-01-1999
			CA 2241128 A1	30-12-1998
			CN 1204874 A , C	13-01-1999
			JP 11097915 A	09-04-1999