

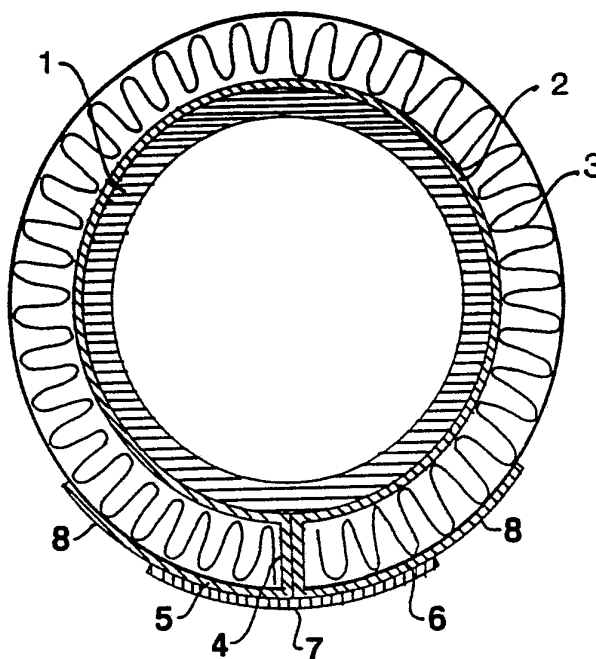

INTERNATIONAL APPLICATION PUBLISHED UNDER THE PATENT COOPERATION TREATY (PCT)

<p>(51) International Patent Classification ⁵ : F16L 59/10, 59/14</p>	<p>A1</p>	<p>(11) International Publication Number: WO 91/18237 (43) International Publication Date: 28 November 1991 (28.11.91)</p>
<p>(21) International Application Number: PCT/DK91/00132 (22) International Filing Date: 14 May 1991 (14.05.91) (30) Priority data: 1192/90 14 May 1990 (14.05.90) DK (71) Applicant (for all designated States except US): V.I.K.-CONSULT APS [DK/DK]; Donsevej 3, DK-2970 Hørsholm (DK). (72) Inventor; and (75) Inventor/Applicant (for US only) : KORSGAARD, Vagn [DK/DK]; Donsevej 3, DK-2970 Hørsholm (DK). (74) Agent: LEHMANN & REE; Frederiksberg Allé 26, DK-1820 Frederiksberg C (DK).</p>		<p>(81) Designated States: AT (European patent), BE (European patent), CH (European patent), DE (European patent), DK (European patent), ES (European patent), FR (European patent), GB (European patent), GR (European patent), IT (European patent), JP, LU (European patent), NL (European patent), SE (European patent), US.</p> <p>Published <i>With international search report.</i></p>
<p>(54) Title: INSULATION SYSTEM AND PROCESS FOR FORMING SUCH AN INSULATION SYSTEM ON A CONDUIT OR CONTAINER</p>		



(57) Abstract

An insulation for a cold pipe (1) comprising an inner water absorbing layer (2) which, through a slot (4) in a surrounding tubular insulation (3), extends out through the slot in the tubular insulation and covers at least part of the external surface of the heat insulating layer.

FOR THE PURPOSES OF INFORMATION ONLY

Codes used to identify States party to the PCT on the front pages of pamphlets publishing international applications under the PCT.

AT	Austria	ES	Spain	MG	Madagascar
AU	Australia	FI	Finland	ML	Mali
BB	Barbados	FR	France	MN	Mongolia
BE	Belgium	GA	Gabon	MR	Mauritania
BF	Burkina Faso	GB	United Kingdom	MW	Malawi
BG	Bulgaria	GN	Guinea	NL	Netherlands
BJ	Benin	GR	Greece	NO	Norway
BR	Brazil	HU	Hungary	PL	Poland
CA	Canada	IT	Italy	RO	Romania
CF	Central African Republic	JP	Japan	SD	Sudan
CG	Congo	KP	Democratic People's Republic of Korea	SE	Sweden
CH	Switzerland	KR	Republic of Korea	SN	Senegal
CI	Côte d'Ivoire	LI	Liechtenstein	SU	Soviet Union
CM	Cameroon	LK	Sri Lanka	TD	Chad
CS	Czechoslovakia	LU	Luxembourg	TG	Togo
DE	Germany	MC	Monaco	US	United States of America
DK	Denmark				

Insulation system and process for forming such an insulation system on a conduit or container

5 The present invention relates to an insulation system comprising a layer of a heat insulating material for a conduit or container having a surface temperature below the dew point of the ambient air. In particular the invention relates to an insulating system for insulating cold pipes and conduits and containers for the transportation or storage of cooling media.

10

It is well-known to insulate hot water pipes by mounting thereon a tubular insulation comprising axially slotted tubular insulating elements. Such tubular insulations are readily mounted and they are effective for preventing loss of heat from the heating pipes.

15

If such tubular insulations are used in connection with cold pipes, moisture inevitably penetrates through the insulation by diffusion and gets into contact with the surface of the cold pipe. If the surface temperature is below the dew point of the ambient air, condensation of water vapour on the cold pipe will occur and thereby the insulation material becomes moist and loses its insulating capacity. Furthermore the insulating material may decompose and the cold pipe may corrode.

20

The removal of moisture from the insulating material normally takes place very slowly as conventional insulation materials have little capillary effect.

25

The result is that the tubular insulation remains moist.

30

The exterior surface of such tubular insulations are usually covered by a layer of a vapour proof material, such as an aluminium foil or a plastic film, in order to slow down the moistening of the insulating material.

35

However, experience shows that unavoidable flaws in the vapour proof foil or film result in severe moistening of the insulating material over the years, and unfortunately in this situation the vapour proof layer will prevent drying of the heat insulating layer by capillary

suction.

Up to now the only solution to this problem has been periodic replacement of the wet insulation.

5

It is the object of the invention to provide an insulation system for conduits and containers of the above mentioned type which instead of preventing water vapours from entering the insulation system ensures that moisture present therein is continuously removed therefrom.

10

This object is obtained with the insulation system according to the invention which system is characterized in that it comprises an inner layer of a water absorbing material, a heat insulating layer located on the exterior side of the layer of water absorbing material and an outer layer of a water absorbing material located on the exterior of the heat insulating layer, the two layers of water absorbing material being in mutual contact through an opening in the heat insulating layer, such that water can be transported from the inner layer to the outer layer by capillary suction.

15

20

When condensation occurs on the exterior side of the conduit or container, the capillary suction will cause the condensed water to be sucked out by the outer layer of water absorbing material and to evaporate from the latter layer.

25

If the insulation material used has a high water vapour permeability, such as mineral wool, the insulation system of the invention preferably further comprises a diffusion proof layer provided on the exterior side of the heat insulating layer within the outer water absorbing layer and having an opening formed therein.

30

In this embodiment of the invention the diffusion proof layer will provide a desired high degree of resistance to the diffusion of water vapour from the surroundings and towards the relatively cold surface of the conduit or container.

35

However, if the insulation material has a low water vapour permeability, such a diffusion proof layer may be omitted.

When the opening in the heat insulating layer is in the form of an axially extended slot, the two layers of water absorbing material preferably are integral and preferably the outer layer consists of two parts which extend in opposite directions from the slot. Such insulation is particularly simple to construct on e.g. straight cold pipes, the only steps required being to place the absorbing layer, e.g. in the form of a piece of felt, on the pipes with its ends in an extending position, and to place tubular insulation elements optionally having a diffusion proof surface layer around said pipe and then to fold the two free ends of the water absorbing layer away from the slot and optionally attach these ends to the exterior side of the heat insulating layer or the diffusion proof layer.

A preferred embodiment of the insulation system of the invention further comprises a layer of a diffusion proof material located externally of the outer layer of water absorbing material and overlapping the opening in the heat insulating layer.

The extent to which said layer of diffusion proof material covers the outer layer of water absorbing material determines the vapour diffusion resistance of the insulation system.

If the opening in the heat insulating layer is an axially extending slot in the heat insulating layer, a suitable diffusion resistance is generally obtained if the outer diffusion proof layer extends a few centimetres perpendicularly to said slot.

The layers of water absorbing material are preferably fibre layers consisting of glass, organic synthetic or natural fibres. An example of a suitable fibre material is a non-woven fabric of hydrophilic synthetic fibres, such as nylon or polypropylene felt having a weight of from 20 to 150 g/m².

The layer of water absorbing material may fully surround the heat insulating layer, but this is not necessary if only its free (not covered) surface is sufficiently large to permit effective evaporation of the condensed water absorbed by the part of the layer which is located on the exterior side of the heat insulating layer.

The heat insulating material may consist of known insulating materials, such as mineral wool and foamed plastic.

5 In the insulation of pipes, a special tubular mineral wool product having a thin, integral inner layer of mineral wool, which has been made water absorbing, may be used as a combined water absorbing layer and heat insulating layer. Said inner layer, which e.g. has a thickness of from 1 to 3 mm, can be made water absorbing during the manufacturing process by increasing the temperature of the inner
10 layer above the temperature at which the water repellent fibre binder decomposes.

The diffusion proof layer on the exterior side of the heat insulating layers may conveniently be of a plastic film or a metal foil,
15 e.g. an aluminium foil.

Another preferred embodiment of the insulation system according to the invention comprises a plastic film having one portion for winding around a conduit and another portion which is adapted to
20 extend out through a slot in the heat insulating layer so as to form a diffusion proof layer on the exterior side of the heat insulating layer and on the exterior side of the outer water absorbing layer in the slot zone. By placing such diffusion proof layer in direct contact with the conduit the risk of corrosion is reduced.

25 The outer diffusion proof layer is preferably a plastic film which can be adhered directly to the exterior side of the outer layer of the water absorbing material.

30 A coat of paint which is open to diffusion may be applied to the exterior side of the latter layer.

The invention also relates to a process for providing a conduit or
35 container with an insulation as described above. This process is characterized in placing an inner layer of a water absorbing material on the exterior side of the conduit or container, placing a heat insulating layer comprising an opening therein in contact with the exterior side of the inner layer of water absorbing material, placing a water absorbing material in said opening and placing an

outer layer of a water absorbing material on the exterior side of the heat insulating layer.

5 If the insulation material used has a high water vapour permeability, such as mineral wool, a diffusion proof layer having an opening formed therein is preferably placed on the exterior side of the heat insulating layer within the outer water absorbing layer.

10 In a preferred embodiment of the process of the invention a layer of diffusion proof material is placed on the exterior side of the outer layer of water absorbing material in the region outside the opening in the heat insulating layer.

15 In another preferred embodiment of the process according to the invention, a diffusion proof layer, such as a plastic film, is placed in direct contact with the exterior surface of the conduit or container thereby preventing condensed water, if any, from getting into direct contact with said surface and provoking corrosion.

20 A particularly simple embodiment for providing a cold pipe with an insulation comprises the steps of wrapping a laminate of a plastic film and a felt around the pipe with the plastic film being proximate to the cold pipe, placing a tubular insulation provided with an axially extending slot around the pipe in such a manner that the
25 laminate extends out through said slot, wrapping the protruding part of the laminate around the heat insulating layer and positioning the plastic film in contact with the exterior side of the tubular insulation. The laminate may be positioned so that at least the plastic film overlaps the slot in the tubular insulation.

30 Instead of using a laminate a separate plastic film and a separate water absorbing layer may be used.

35 The invention will now be described in further detail with reference to the accompanying drawing wherein

Fig. 1 is a schematic cross-sectional view of a pipe comprising a preferred embodiment of an insulation according to the invention,

Fig. 2 is a schematic cross-sectional view of a pipe comprising an alternative preferred embodiment of the insulation according to the invention,

5 Fig. 3 is a schematic cross-sectional view of a pipe for the transportation of a liquid having a temperature of below 0°C comprising a preferred embodiment of an insulation according to the invention, and

10 Fig. 4 shows a schematic cross-sectional view of a pipe for the transportation of a liquid having a temperature of 0°C comprising an alternative preferred embodiment according to the invention.

15 Fig. 1 shows a cold pipe 1 surrounded by a felt layer 2 which is surrounded by a layer 3 of a heat insulating layer having a low water vapour permeability, such as a synthetic foam with closed cells. The heat insulating layer 3 comprises an axially extending slot 4, and parts 5,6 of the felt layer 2 extend through the slot 4
20 and are placed parallel to the outer surface of the heat insulating layer 3. A plastic film 7 is adhered to the exterior side of the parts 5,6 in the region outside the slot 4, said plastic film 7 extending to both sides of the slot 4, but not far enough to cover the parts 5,6 completely. Thus a free (not covered) surface 8 is
25 formed on the parts 5,6 from which evaporation of water may take place.

In Fig. 2 11 denotes a cold pipe. The pipe 11 is surrounded by a laminate comprising a plastic film 12 and a water absorbing felt layer 13. The laminate is placed within a tubular insulation 14 consisting of a mineral fibre layer 15. The tubular insulation is provided with an axially extending slot 16 and part of the laminate extends out through said slot and is wrapped around the tubular insulation in such a manner that the plastic film 12 overlaps
30 itself in the region outside the slot 16, whereas the water absorbing felt layer 13 extends over only part of the periphery of the pipe so as to form a zone 17 having a free (not covered) surface through which evaporation may take place and a zone 18 located
35 between the overlapping parts of the plastic film 12.

Alternatively, the laminate may be wrapped all around the tubular insulation so as to overlap itself in the region outside the slot 16.

5 For condensation of water vapour contained in the ambient air to occur, the water vapour must diffuse through the felt layers 2,13. This diffusion route is relatively long and only a limited condensation will ordinarily occur on the exterior surface of the pipe 1 or on that part of the plastic film 12 which is in contact with the
10 pipe 11.

Condensed water will be sucked out from the part of the felt layer 2,13 surrounding the pipe and through the slot 4,16 to that part of the felt layer 5,6,13 which is located on the exterior side of the
15 insulating layer 3,14 due to the capillary suction prevailing in the felt layer 2,13 and will evaporate from the regions which are not covered by the plastic film 7,12.

20 When the pipe to be insulated has an outer surface temperature of below the freezing point of water, the condensed water will freeze to form ice.

The embodiments of the invention shown in Figs. 1 and 2 can be used to isolate cold pipes having an outer surface temperature of below
25 0°C provided that said pipe temperature is, at intervals, raised to a level above 0°C, e.g. in connection with maintenance routines.

In Figs. 3 and 4 embodiments of the invention are shown, which are particularly suitable for insulating pipes having an outer surface
30 temperature of below 0°C, e.g. below -5°C.

Fig. 3 shows a pipe 30, which is surrounded by a laminate 31 comprising a plastic film 32 and a layer of water absorbing material 33.

35 The laminate 31 is wrapped around the pipe 30 with the plastic film 32 located adjacent to the surface of the pipe 30. The laminate extends out through an axially extending slot 34 in a first layer 35 of a heat insulating material and around said layer and also out through an axially extending slot 36 in a second layer 37 of a heat

insulating material.

5 The laminate 31 also surrounds the second layer 37 of heat insulating material and ends in proximity to the slot 36. The region outside the slot 36 is covered by an axially extending plastic film strip 38.

10 Fig. 4 shows a pipe 40, which is surrounded by a layer of water absorbing material 41. Parts 42,43 of the water absorbing layer 41 extend out through an axially extending slot 44 in a first layer 45 of a heat insulating material having a plastic film 46 fixed to its exterior side and also out through an axially extending slot 47 in a second layer 48 of a heat insulating material having a plastic film 49 fixed to its exterior side.

15 The combination of the first heat insulating layer 45 and the plastic film 46 is surrounded by a second water absorbing layer 50 having parts 51,52 extending out through the slot 47 in the second heat insulating layer 48.

20 The part 51 is wrapped around the plastic film 49 of the second heat insulating layer 48 while parts 42,43 and 52 may be cut off at the exterior end of the slot 47.

25 The region outside the slot 47 is covered by an axially extending adhesive tape 53 open to water vapour diffusion and extending to both sides of the slot 47. This adhesive tape 53 serves to keep the insulation system together.

30 The part 51 of the second water absorbing layer 50 need not be wrapped all around the second heat insulating layer 48, but may e.g. only extend 1-10 cm outside the adhesive tape, depending on the pipe diameter, to form a sufficient evaporation area to prevent dripping.

35 In the insulation systems shown in Figs. 3 and 4 the first heat insulating layer 35,45 serves to maintain the surface of said layer at a temperature above 0°C, e.g. 1°C, and the water absorbing layer which is located within the second heat insulating layer 37,48 serves to remove water which may have been accumulated in the zone

between the pipe 30,40 and the heat insulating layer 37,48 in the form of ice during periods when the temperature at the surface of the pipe raises to above 0°C. The water removed in such periods as well as water formed by condensation in the zone between the first and second layers of heat insulating material migrate to the surface of the insulation from which it is evaporated.

10

15

20

25

30

35

C l a i m s

1. An insulation system comprising a layer (3, 15) of a heat insulating material for a conduit or container having a surface temperature below the dew point of the ambient air, characterized in that it comprises an inner layer (2, 13) of a water absorbing material, a heat insulating layer (3, 14) located on the exterior side of the layer of water absorbing material and an outer layer (5, 6, 13) of a water absorbing material located on the exterior side of the heat insulating layer, the two layers of water absorbing material being in mutual contact through an opening (4, 16) in the heat insulating layer (3, 14) such that water can be transported from the inner layer to the outer layer by the capillary suction.
2. An insulation system according to claim 1, characterized in that it comprises a diffusion proof layer (12) provided on the exterior side of the heat insulating layer (14) within the outer water absorbing layer (13) and having an opening (16) formed therein.
3. An insulation system according claim 1 or 2, characterized in that a layer (7, 12) of diffusion proof material is located externally of the outer layer (5, 6, 13) of a water absorbing material and overlapping the opening (4, 16) in the heat insulating layer.
4. An insulation system according to any of the preceding claims wherein the opening in the heat insulating layer is constituted of an axially extending slot (4, 16), characterized in that the two layers (2, 5, 6) of water absorbing material are integral and that the outer layer consists of two parts (5, 6) which extend in opposite directions from the slot.
5. An insulation system according to any of the preceding claims, characterized in that it comprises a plastic film (12) having one portion for winding around the conduit (1, 11) and another portion which is adapted to extend out through a slot in the heat insulating layer so as to form a diffusion proof layer on the

exterior side of the heat insulating layer and on the exterior side of the outer water absorbing layer in the slot zone.

5 6. An insulation system according to any of the preceding claims, characterized in that the opening in the heat insulating layer is an axially extending slot (4, 16), and that the outer diffusion proof layer consists of a plastic strip (7).

10 7. A process for providing a conduit or container with an insulation system according to claim 1, characterized in placing an inner layer of a water absorbing material (2, 13) on the exterior surface of the conduit or container (1, 11), placing a heat insulating layer (3, 14) comprising an opening (4, 16) therein in contact with the exterior side of the inner layer of water absorbing material (2, 13), placing a water absorbing material in said opening and placing an outer layer (5, 6, 13) of a water absorbing material on the exterior side of the heat insulating layer (3, 14).

20 8. A process according to claim 7, characterized in placing a diffusion proof layer (12) having an opening (16) formed therein on the exterior side of the heat insulating layer (14) within the outer water absorbing layer (5, 6, 13).

25 9. A process according to claim 7 or 8, characterized in placing a layer of diffusion proof material (7, 12) on the exterior side of the outer layer of water absorbing material (5, 6, 13) in the region outside the opening (4, 16) in the heat insulating layer (3, 14).

30 10. A process according to claim 7, 8 or 9, characterized in locating a layer (12) of a diffusion proof material in direct contact with the exterior side of the conduit or container (1, 11).

35 11. A process according to claim 10 for providing an insulation system on a cold pipe (11), characterized in wrapping a laminate (12, 13) of a plastic film and a felt around the pipe (11) with the plastic film (12) being proximate to the cold pipe (11), placing a tubular insulation (14) provided with an

axially extending slot (16) around the pipe (11) in such a manner
that the laminate (12, 13) extends out through said slot (16),
wrapping the protruding part of the laminate (12, 13) around the
heat insulating layer (14) and positioning the plastic film (12) in
5 contact with the exterior side of the tubular insulation (14).

12. A process according to claim 11, c h a r a c t e r i z e d in
positioning the laminate (12, 13) so that at least the plastic film
(12) overlaps the slot (16) in the tubular insulation (14).

10

15

20

25

30

35

FIG. 1

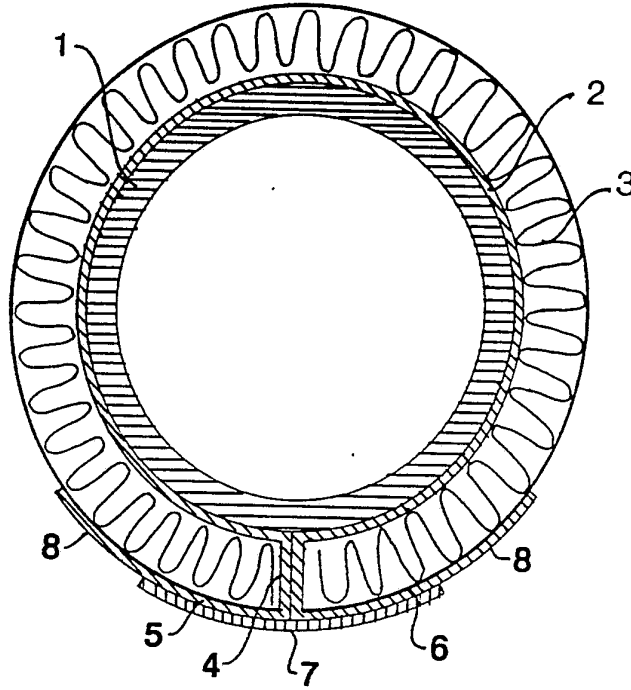
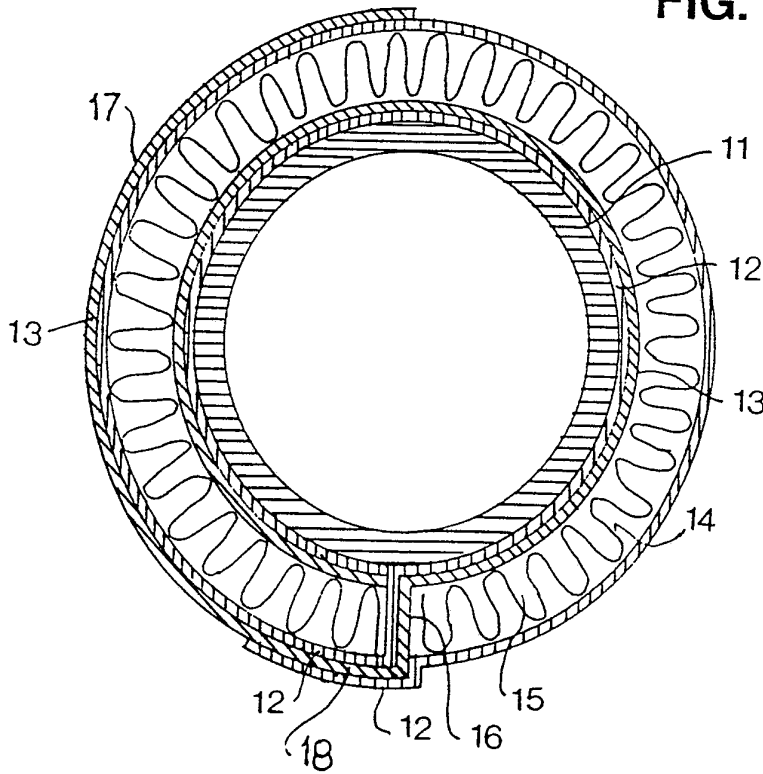

FIG. 2



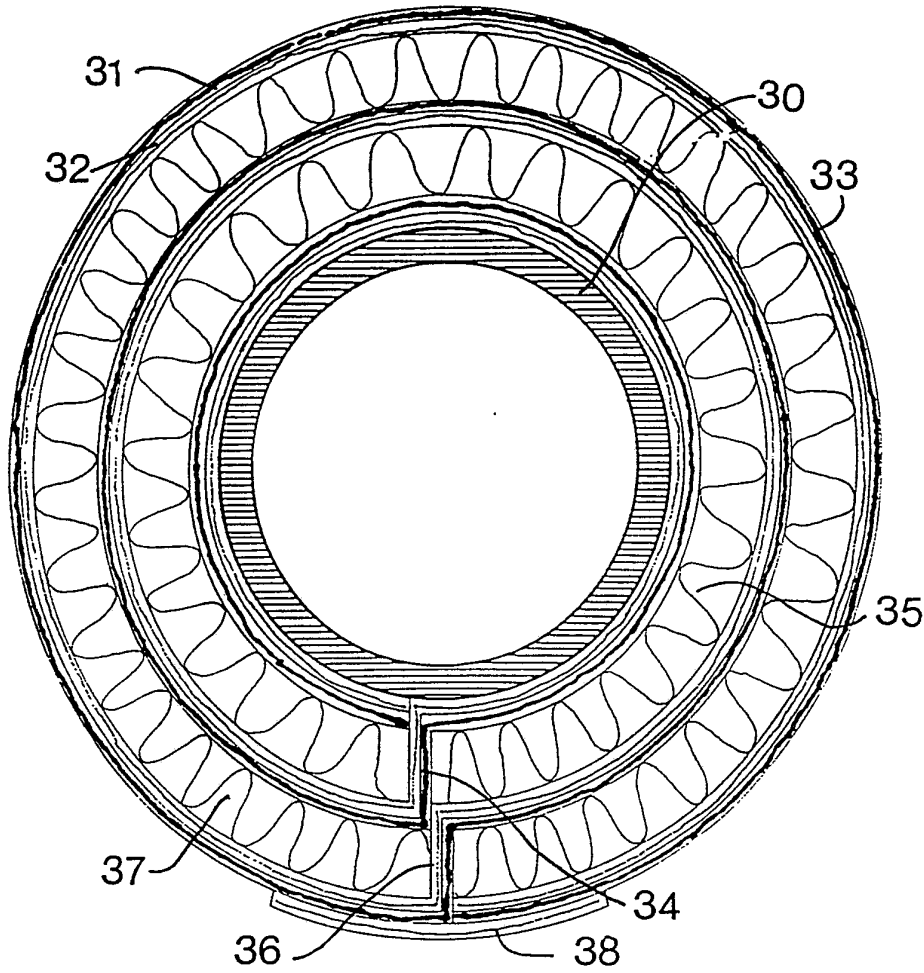

FIG. 3

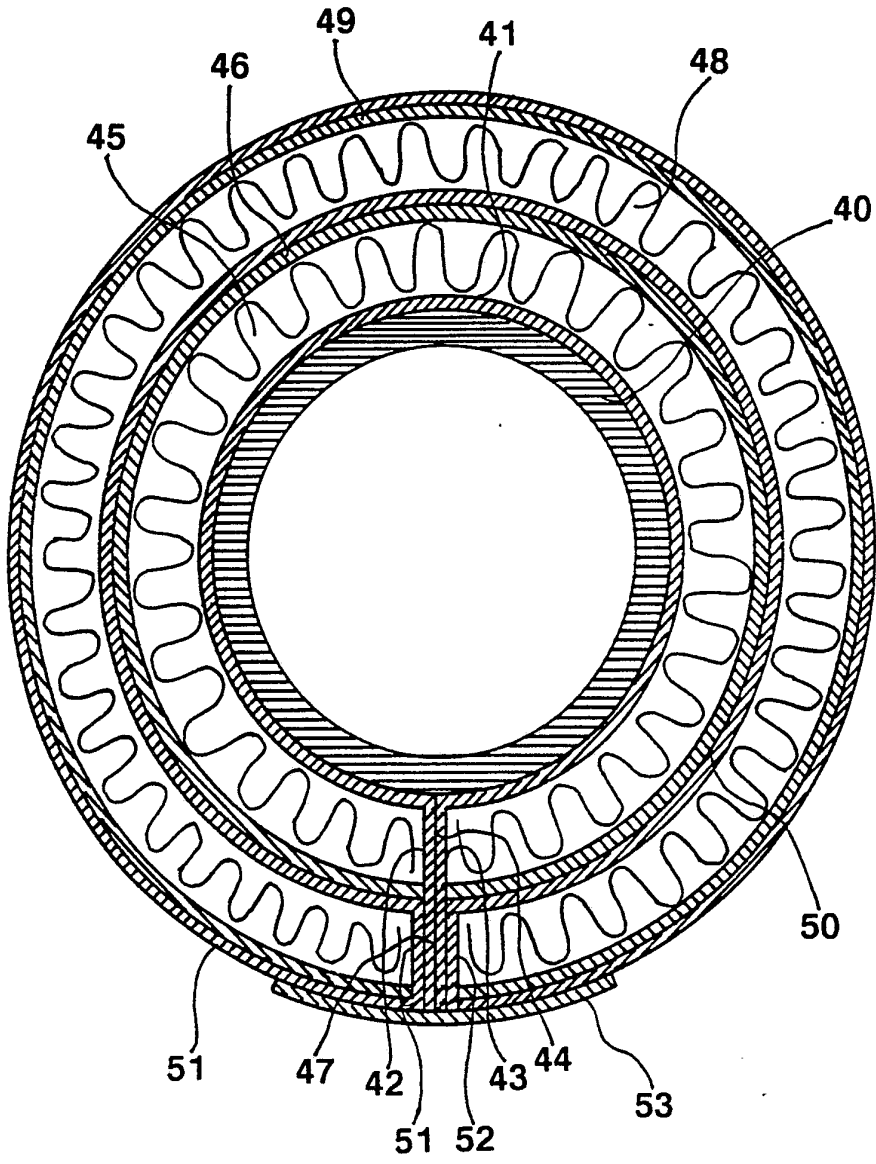

FIG. 4

INTERNATIONAL SEARCH REPORT

International Application No PCT/DK 91/00132

I. CLASSIFICATION OF SUBJECT MATTER (if several classification symbols apply, indicate all) ⁶ According to International Patent Classification (IPC) or to both National Classification and IPC IPC5: F 16 L 59/10, 59/14																	
II. FIELDS SEARCHED <div style="text-align: center; margin-top: 5px;">Minimum Documentation Searched⁷</div> <table border="1" style="width: 100%; border-collapse: collapse; margin-top: 5px;"> <tr> <td style="width: 25%; padding: 5px;">Classification System</td> <td style="padding: 5px;">Classification Symbols</td> </tr> <tr> <td style="padding: 5px;">IPC5</td> <td style="padding: 5px;">F 16 L</td> </tr> </table> <div style="text-align: center; margin-top: 5px;">Documentation Searched other than Minimum Documentation to the Extent that such Documents are Included in Fields Searched⁸</div> <p style="margin-top: 10px;">SE,DK,FI,NO classes as above</p>			Classification System	Classification Symbols	IPC5	F 16 L											
Classification System	Classification Symbols																
IPC5	F 16 L																
III. DOCUMENTS CONSIDERED TO BE RELEVANT⁹ <table border="1" style="width: 100%; border-collapse: collapse; margin-top: 5px;"> <thead> <tr> <th style="width: 10%; padding: 5px;">Category *</th> <th style="width: 70%; padding: 5px;">Citation of Document,¹¹ with indication, where appropriate, of the relevant passages¹²</th> <th style="width: 20%; padding: 5px;">Relevant to Claim No.¹³</th> </tr> </thead> <tbody> <tr> <td style="text-align: center; vertical-align: top; padding: 5px;">A</td> <td style="padding: 5px;">WO, A1, 8912199 (REGAL TECHNOLOGY LTD.) 14 December 1989, see page 5, line 30 - line 32 --</td> <td style="text-align: center; vertical-align: top; padding: 5px;">1-2</td> </tr> <tr> <td style="text-align: center; vertical-align: top; padding: 5px;">A</td> <td style="padding: 5px;">US, A, 4745760 (WARREN W. PORTER) 24 May 1988, see column 3, line 33 - line 39 --</td> <td style="text-align: center; vertical-align: top; padding: 5px;">1-12</td> </tr> <tr> <td style="text-align: center; vertical-align: top; padding: 5px;">A</td> <td style="padding: 5px;">CH, A, 181327 (KARL WERNER) 15 December 1935, see the whole document --</td> <td style="text-align: center; vertical-align: top; padding: 5px;">1-12</td> </tr> <tr> <td style="text-align: center; vertical-align: top; padding: 5px;">A</td> <td style="padding: 5px;">SE, C, 123644 (J.M.E. JOHANSSON) 21 December 1948, see the whole document --</td> <td style="text-align: center; vertical-align: top; padding: 5px;">1-12</td> </tr> </tbody> </table>			Category *	Citation of Document, ¹¹ with indication, where appropriate, of the relevant passages ¹²	Relevant to Claim No. ¹³	A	WO, A1, 8912199 (REGAL TECHNOLOGY LTD.) 14 December 1989, see page 5, line 30 - line 32 --	1-2	A	US, A, 4745760 (WARREN W. PORTER) 24 May 1988, see column 3, line 33 - line 39 --	1-12	A	CH, A, 181327 (KARL WERNER) 15 December 1935, see the whole document --	1-12	A	SE, C, 123644 (J.M.E. JOHANSSON) 21 December 1948, see the whole document --	1-12
Category *	Citation of Document, ¹¹ with indication, where appropriate, of the relevant passages ¹²	Relevant to Claim No. ¹³															
A	WO, A1, 8912199 (REGAL TECHNOLOGY LTD.) 14 December 1989, see page 5, line 30 - line 32 --	1-2															
A	US, A, 4745760 (WARREN W. PORTER) 24 May 1988, see column 3, line 33 - line 39 --	1-12															
A	CH, A, 181327 (KARL WERNER) 15 December 1935, see the whole document --	1-12															
A	SE, C, 123644 (J.M.E. JOHANSSON) 21 December 1948, see the whole document --	1-12															
<table style="width: 100%; border: none;"> <tr> <td style="width: 50%; vertical-align: top; border: none;"> <p>* Special categories of cited documents: ¹⁰</p> <p>"A" document defining the general state of the art which is not considered to be of particular relevance</p> <p>"E" earlier document but published on or after the international filing date</p> <p>"L" document which may throw doubts on priority claim(s) or which is cited to establish the publication date of another citation or other special reason (as specified)</p> <p>"O" document referring to an oral disclosure, use, exhibition or other means</p> <p>"P" document published prior to the international filing date but later than the priority date claimed</p> </td> <td style="width: 50%; vertical-align: top; border: none;"> <p>"T" later document published after the international filing date or priority date and not in conflict with the application but cited to understand the principle or theory underlying the invention</p> <p>"X" document of particular relevance, the claimed invention cannot be considered novel or cannot be considered to involve an inventive step</p> <p>"Y" document of particular relevance, the claimed invention cannot be considered to involve an inventive step when the document is combined with one or more other such documents, such combination being obvious to a person skilled in the art.</p> <p>"&" document member of the same patent family</p> </td> </tr> </table>			<p>* Special categories of cited documents: ¹⁰</p> <p>"A" document defining the general state of the art which is not considered to be of particular relevance</p> <p>"E" earlier document but published on or after the international filing date</p> <p>"L" document which may throw doubts on priority claim(s) or which is cited to establish the publication date of another citation or other special reason (as specified)</p> <p>"O" document referring to an oral disclosure, use, exhibition or other means</p> <p>"P" document published prior to the international filing date but later than the priority date claimed</p>	<p>"T" later document published after the international filing date or priority date and not in conflict with the application but cited to understand the principle or theory underlying the invention</p> <p>"X" document of particular relevance, the claimed invention cannot be considered novel or cannot be considered to involve an inventive step</p> <p>"Y" document of particular relevance, the claimed invention cannot be considered to involve an inventive step when the document is combined with one or more other such documents, such combination being obvious to a person skilled in the art.</p> <p>"&" document member of the same patent family</p>													
<p>* Special categories of cited documents: ¹⁰</p> <p>"A" document defining the general state of the art which is not considered to be of particular relevance</p> <p>"E" earlier document but published on or after the international filing date</p> <p>"L" document which may throw doubts on priority claim(s) or which is cited to establish the publication date of another citation or other special reason (as specified)</p> <p>"O" document referring to an oral disclosure, use, exhibition or other means</p> <p>"P" document published prior to the international filing date but later than the priority date claimed</p>	<p>"T" later document published after the international filing date or priority date and not in conflict with the application but cited to understand the principle or theory underlying the invention</p> <p>"X" document of particular relevance, the claimed invention cannot be considered novel or cannot be considered to involve an inventive step</p> <p>"Y" document of particular relevance, the claimed invention cannot be considered to involve an inventive step when the document is combined with one or more other such documents, such combination being obvious to a person skilled in the art.</p> <p>"&" document member of the same patent family</p>																
IV. CERTIFICATION <table border="1" style="width: 100%; border-collapse: collapse; margin-top: 5px;"> <tr> <td style="width: 50%; padding: 5px;">Date of the Actual Completion of the International Search</td> <td style="padding: 5px;">Date of Mailing of this International Search Report</td> </tr> <tr> <td style="padding: 5px;">15th August 1991</td> <td style="text-align: center; padding: 5px;">1991 -08- 2 0</td> </tr> <tr> <td style="padding: 5px;">International Searching Authority</td> <td style="padding: 5px;">Signature of Authorized Officer</td> </tr> <tr> <td style="text-align: center; padding: 5px;">SWEDISH PATENT OFFICE</td> <td style="text-align: center; padding: 5px;"> Erik Svensson </td> </tr> </table>			Date of the Actual Completion of the International Search	Date of Mailing of this International Search Report	15th August 1991	1991 -08- 2 0	International Searching Authority	Signature of Authorized Officer	SWEDISH PATENT OFFICE	 Erik Svensson							
Date of the Actual Completion of the International Search	Date of Mailing of this International Search Report																
15th August 1991	1991 -08- 2 0																
International Searching Authority	Signature of Authorized Officer																
SWEDISH PATENT OFFICE	 Erik Svensson																

III. DOCUMENTS CONSIDERED TO BE RELEVANT (CONTINUED FROM THE SECOND SHEET)		
Category *	Citation of Document, with indication, where appropriate, of the relevant passages	Relevant to Claim No
A	<p>Dialog Information Services, File 351, World Patent Index 81-91, Dialog accession no. 007097054, Mitsubishi Plastics Ind: "Heat insulating pipe mfr. by heating precast metallic pipe, covering surface with foamable thermoplastic resin as pipe is inserted into cross head die and foaming", JP 62044421, A, 870226, 8714 (Basic)</p> <p style="text-align: center;">-- -----</p>	1-12

**ANNEX TO THE INTERNATIONAL SEARCH REPORT
ON INTERNATIONAL PATENT APPLICATION NO.PCT/DK 91/00132**

This annex lists the patent family members relating to the patent documents cited in the above-mentioned international search report. The members are as contained in the Swedish Patent Office EDP file on **91-06-27**. The Swedish Patent Office is in no way liable for these particulars which are merely given for the purpose of information.

Patent document cited in search report	Publication date	Patent family member(s)	Publication date
WO-A1- 8912199	89-12-14	AU-D- 2766388	89-07-13
		GB-A- 2214235	89-08-31
		GB-A- 2229246	90-09-19
US-A- 4745760	88-05-24	EP-A- 0324030	89-07-19
		JP-T- 2500476	90-02-15
		WO-A- 89/00656	89-01-26
CH-A- 181327	35-12-15	NONE	
SE-C- 123644	48-12-21	NONE	