



(11) **EP 1 759 781 B1**

(12) **EUROPEAN PATENT SPECIFICATION**

(45) Date of publication and mention of the grant of the patent:  
**06.07.2011 Bulletin 2011/27**

(51) Int Cl.:  
**B21D 22/20** <sup>(2006.01)</sup> **B22D 17/00** <sup>(2006.01)</sup>  
**B22D 17/22** <sup>(2006.01)</sup>

(21) Application number: **05743302.1**

(86) International application number:  
**PCT/JP2005/009801**

(22) Date of filing: **27.05.2005**

(87) International publication number:  
**WO 2005/115653 (08.12.2005 Gazette 2005/49)**

(54) **METHOD FOR FORMING METALLIC GLASS**

VERFAHREN ZUR HERSTELLUNG VON METALLGLAS

MÉTHODE DE FORMATION DE VERRE MÉTALLIQUE

(84) Designated Contracting States:  
**DE FI FR GB SE**

(30) Priority: **28.05.2004 JP 2004160234**

(43) Date of publication of application:  
**07.03.2007 Bulletin 2007/10**

(73) Proprietors:  
• **NGK Insulators, Ltd.**  
**Nagoya-shi, Aichi 467-8530 (JP)**  
• **TOHOKU UNIVERSITY**  
**Aoba-ku**  
**Sendai-shi, Miyagi 980-8577 (JP)**

(72) Inventors:  
• **MURAMATSU, Naokuni**  
**Nagoya-chi,**  
**Aichi 467-8530 (JP)**  
• **SUZUKI, Kenment**  
**Nagoya-shi,**  
**Aichi 467-8530 (JP)**  
• **INOUE, Akihisa**  
**Aoba-ku, Sendai-shi,**  
**Miyagi 989-0861 (JP)**

• **KIMURA, Hisamichi**  
**Watari-gun,**  
**Miyagi 989-2311 (JP)**

(74) Representative: **Paget, Hugh Charles Edward et al**  
**Mewburn Ellis LLP**  
**33 Gutter Lane**  
**London**  
**EC2V 8AS (GB)**

(56) References cited:  
**JP-A- 2 175 039** **JP-A- 55 063 676**  
**JP-A- 2000 301 316** **JP-A- 2000 317 900**  
**JP-A- 2001 347 351** **JP-A- 2002 086 258**  
**JP-A- 2002 192 294** **JP-A- 2002 361 399**  
**JP-A- 2003 117 647** **JP-A- 2004 098 125**

• **HATA S. ET AL: 'Usumaku Kinzoku Glass o Mochiita Bisai Kozobutsu no Seisaku (Dai 1 Ho)'**  
**JOURNAL OF THE JAPAN SOCIETY OF PRECISION ENGINEERING** vol. 66, no. 1, 05  
January 2000, pages 96 - 97, XP003002866

Note: Within nine months of the publication of the mention of the grant of the European patent in the European Patent Bulletin, any person may give notice to the European Patent Office of opposition to that patent, in accordance with the Implementing Regulations. Notice of opposition shall not be deemed to have been filed until the opposition fee has been paid. (Art. 99(1) European Patent Convention).

**EP 1 759 781 B1**

## Description

### TECHNICAL FIELD

**[0001]** The present invention relates to a method of forming a metallic glass into a thin-wall component such as an electronic equipment cabinet.

### BACKGROUND ART

**[0002]** Metallic liquid normally enters an extremely unstable state when cooled below a melting point, and is immediately crystallized to become crystallized metal. In this event, time for which a supercooled liquid can exist in an uncrystallized state where atoms are randomly arranged, i.e., a so-called "amorphous state," is estimated to be  $10^{-5}$  seconds or less at a nose temperature of a continuous cooling transformation (CCT) curve. Specifically, this means that it is impossible to obtain amorphous alloys unless a cooling rate of  $10^6$  K/s or more is achieved.

**[0003]** However, there has recently been invented metallic glass which undergoes clear glass transition and is not crystallized even at a cooling rate of 100 K/s or less since a supercooled liquid state is extremely stabilized in a specific alloy group including a zirconium base (see, for example, The June 2002 edition of Kinou Zairyou (Functional Materials), Vol. 22, No. 6, p.p.5-9; Non-patent Document 1).

**[0004]** Each of these metallic glasses has a wide temperature range (supercooled liquid temperature range) in which a supercooled liquid state can be maintained. For this reason, superplastic forming by means of viscous flow can be performed on each of the metallic glasses (see, for example, The July 2002 edition of Kinou Zairyou (Functional Materials), Vol. 22, No. 7, p.p. 5-8; Non-patent Document 2) under a condition that a temperature and a time period are not reached temperature range causing crystallization.

**[0005]** Additionally, it is known that a large-shaped amorphous alloy (a bulk metallic glass) can be manufactured directly from molten metal by any one of manufacturing methods such as a water quenching method, an arc melting method, a permanent mold casting method, a high-pressure injection molding method, a suction casting method, a mold-clamp casting method and a rotating-disc fiber manufacturing method (see, for example, The June 2002 edition of Kinou Zairyou (Functional Materials), Vol. 22, No. 6, p.p.26-31; Non-patent Document 3).

**[0006]** Metallic glasses manufactured by these manufacturing methods can provide mechanical properties even in large sizes, which may otherwise be lacking in crystalline alloys. The mechanical properties include a high strength and a low Young's modulus and a high elastic limit, which are inherent in the amorphous state. For this reason, the metallic glasses are expected to be widely put into practical use as structural materials.

**[0007]** Metallic glasses are originally suitable for ap-

plication to thin-wall molded articles, such as an electronic equipment cabinet, for which three-dimensional shapes realizing high strengths and light weights are favored. There are, however, problems as described below with the above described manufacturing methods of obtaining large-shaped metallic glass components.

**[0008]** Firstly, the permanent mold casting method has the following problems. The general permanent mold casting method is a simple method with which molten metal is simply poured into a molding cavity of a die. Therefore, depending on the shape of the component, it is difficult to avoid shape losses due to insufficient run of spreading of the molten metal, and casting defects such as cold shut and blowholes. Additionally, a cooling rate from the die is unstable, and thus it frequently occurs that part of molten metal is not turned amorphous.

**[0009]** Secondly, the high-pressure injection molding method has the following problems. The general high-pressure injection molding method (for example, Japanese Patent Publication No. Hei 10-296424) is capable of molding a subject into a three-dimensional shape by supplementing insufficient run of spreading of the molten metal by high-pressure injection. However, formation of a complicated runner as shown in Figs. 6 to 8 in Japanese Patent Publication No. Hei10-296424 is required in order to obtain a more complicated shape where a boss, a rib and the like are further provided.

**[0010]** Furthermore, in order to reduce the casting defects as described above, there has remained a complication where devices such as an air vent (a gas exhausting passage) and an overflow (a waste molten metal tank) have to be elaborately added.

**[0011]** Defective rates due to the casting defects of the die casting are generally assumed to be several percent to several tens percent even by using such techniques based on experiences of those who skilled in the art. This indicates that there is no technique by which casting defects can be innovatively prevented in the high-pressure injection molding method.

**[0012]** Thirdly, a melt-forging method has the following problem. In the melt-forging method or the mold-clamp casting method where a molten metal of a metallic glass, which has been arc melted on a water-cooled copper casting mold, is immediately forged and molded. The copper casting mold is water-cooled from a backside so as to prevent a surface of the mold from being heated to a high temperature and being melted at the time of arc-melting.

**[0013]** In locations of a water-cooled portion which make contact with the surface of the mold, melting is insufficient and the metallic glass is not formed. For this reason, locations not suitable for finished article are remained in a molded article, and there is a disadvantage that these parts have to be removed.

**[0014]** In order to avoid this problem, a forging method has been proposed (refer to Japanese Patent Translation 2003-534925). In the method, the mold and a material alloy are heated together to a temperature equal to or

more than a melting point of the metallic glass, and then high-speed molding is performed on the material alloy by pressurization, by use of a mold made of silicon

**[0015]** Nevertheless, although this forging method is applicable to a simple shape such as a plate material, a cutting process of the mold is a problem in applying this method to an article having a complicated three-dimensional shape.

**[0016]** Furthermore, in the melt-forging method, since molding is performed by closing the mold at an instantaneous speed, it is difficult to control a thickness of a molded article with high accuracy in the order of 1 mm or less. Accordingly, there is a critical problem that the method is not easily applicable to a thin-wall or nonuniform-wall molded article.

**[0017]** Fourthly, a press forming method has the following problem. For example, in Japanese Patent Publication No. Hei10-216920, shown is a method of forming a block-shaped amorphous alloy, which has been heated to a supercooled liquid temperature range, by pressing it against an occluded section of a die placed in a vacuum chamber.

**[0018]** In this method, it is extremely difficult to finish the amorphous alloy into a complicated three-dimensional shape where a boss, a rib, a window frame, a hole and the like are provided, in a single time of press forming. Furthermore, since arrangement and removal of a heater and a cooling device are repeated, it is difficult to successively form complicated shapes requiring high measurement accuracy in short cycle times.

**[0019]** Consequently, in order to solve the above described problems, the present inventors advanced experiments and researches by trying various methods. They took into account a point that it is only necessary to mainly manage measurement changes due to thermal expansion and shrinkage because solidification shrinkage does not occur when a metallic glass solidifies as supercooled liquid without crystallizing from the molten metal. Accordingly, they obtained a finding that surface defects can be cleared away in the following manner. Firstly, necessary outline measurements and three-dimensional shape sections are formed by performing pre-forming by die casting in which injection is performed at a high pressure. Then, warm pressing dies forming a cavity conforming to the outline measurements are prepared. Subsequently, a pre-formed semi-article is arranged between the dies heated to a supercooled liquid temperature range, and warm press forming is performed thereon by pressing with the dies. By this way, material surrounding surface defects remained on a surface of the pre-formed semi-article is filled into the surface defects by means of viscous flow.

**[0020]** In addition, they obtained the following finding. A cavity portion is formed in the warm pressing dies in a manner where the cavity portion has a gap of 1 mm or less. Accordingly, finishing forming in which viscous flow specific to the metallic glass is utilized becomes possible, and this is also suitable for a complicated shape having

a nonuniform-wall or a thin-wall in three-dimension.

**[0021]** As a result of further continuing ardent studies based on the findings as described above, the present inventors and others reached completion of the present invention.

US2002/0072203 describes a method for producing a thin film structure, for example of metallic glass, in which in a first step a thin film of the metallic glass is formed on a substrate. In the second step, the thin film is heated to a temperature within the supercooled liquid phase region and is deformed to a desired shape. It is mentioned that at the temperature within the supercooled liquid phase region, the thin film becomes in a state of viscous flow. The thin film is formed on the substrate by sputtering or CVD. The deformation of the thin film in the supercooled liquid phase temperature region is performed using the weight of the film, by deforming the thin film through mechanical external force, such as a micropin, by using electrostatic external force by using magnetic external force or by using a bimorph effect.

## DISCLOSURE OF THE INVENTION

**[0022]** Consequently, the present invention was made in consideration of the above points, and aims to provide a method of forming a metallic glass, which is capable of: forming a formed article, in which no surface defects are generated, by maintaining an amorphous state of the metallic glass; forming a formed component with high measurement accuracy in simplified processes by using dies whose structures are simple; and easily forming the metallic glass into any one of a formed article having a thin-wall or nonuniform-wall, and a formed article having a complicated shape.

**[0023]** A first aspect of the present invention is to provide a method of forming a metallic glass as set out in claim 1.

**[0024]** In the first aspect of the present invention, a formed article obtained by performing the warm press forming may have a thickness of 1 mm or less.

**[0025]** In the first aspect of the present invention, the pre-forming by the die casting may be performed by ventilating an inert gas.

**[0026]** In the first aspect of the present invention, the metallic glass may be melted by using a YAG laser as a heat source in the pre-forming by the die casting.

**[0027]** In the first aspect of the present invention, the warm press forming may be performed by heating the pre-formed semi-article to the supercooled liquid temperature range in atmosphere.

**[0028]** In the first aspect of the present invention, the heating to the supercooled liquid temperature range may be performed by setting the pre-formed semi-article into dies. A heater is provided inside of the respective dies.

**[0029]** In the first aspect of the present invention, the warm press forming may be performed by heating the pre-formed semi-article to the supercooled liquid temperature range after a powder film for blocking atmosphere

is applied to the pre-formed semi-article.

**[0030]** In the first aspect of the present invention, the warm press forming may be performed by heating the pre-formed semi-article to the supercooled liquid temperature range after a surface roughness of the pre-formed semi-article is controlled to be in a range of equal to or more than 0.1  $\mu\text{m}$  and equal to or less than 5  $\mu\text{m}$  in arithmetic average roughness.

**[0031]** In the first aspect of the present invention, the metallic glass may be a zirconium-based metallic glass.

## BRIEF DESCRIPTION OF THE DRAWINGS

### [0032]

Fig. 1A is a view showing a die casting apparatus used in pre-forming by die casting in a method of forming a metallic glass according to a first embodiment of the present invention, and Fig. 1B is a view showing a warm pressing apparatus used in finishing forming by warm pressing in the method of forming a metallic glass according to the first embodiment of the present invention.

Fig. 2A shows a cross sectional view of a pre-formed semi-article before performing the finishing forming thereon by the warm pressing in the method of forming a metallic glass according to the first embodiment of the present invention, and Fig. 2B is a view showing a state of the finishing forming by the warm pressing in the method of forming a metallic glass according to the first embodiment of the present invention. Fig. 3 is a view for explaining the pre-forming by die casting, which is performed by ventilating an inert gas, in the method of forming a metallic glass according to the first embodiment of the present invention.

Fig. 4 is a view for explaining the melting of the metallic glass by a YAG laser at the time of the pre-forming by die casting in the method of forming a metallic glass according to the first embodiment of the present invention.

Fig. 5 is a schematic explanatory view of dies each including heaters, used in the warm pressing in the method of forming a metallic glass according to the first embodiment of the present invention.

Fig. 6 is a cross-sectional view of the pre-formed semi-article having a powder film applied thereon, to which the warm pressing in the method of forming a metallic glass according to the first embodiment of the present invention is applied.

Fig. 7 is a cross-sectional view of the pre-formed semi-article having a controlled surface roughness, to which the warm pressing in the method of molding a metallic glass according to the first embodiment of the present invention is applied.

Fig. 8A is a table showing evaluation results regarding metallic glasses according respectively to Examples 1 to 9 and Comparative Examples 1 to 5.

Fig. 8B is a table showing evaluation results regarding the metallic glasses according respectively to Examples 1 to 9 and Comparative Examples 1 to 5.

## 5 BEST MODES FOR CARRYING OUT THE INVENTION

[First Embodiment of the Present Invention]

**[0033]** Referring to the drawings, a method of forming a metallic glass according to a first embodiment of the present invention will be described below.

**[0034]** Fig. 1A shows a die casting apparatus 1 applied to the method of forming a metallic glass according to the first embodiment of the present invention. Fig. 1B shows a warm pressing apparatus 10 applied to the method of forming a metallic glass according to the first embodiment of the present invention.

**[0035]** The method of forming a metallic glass according to this embodiment is to obtain a formed article made of a metallic glass through the following processes. A pre-formed semi-article is molded by performing pre-forming on the metallic glass by die casting. Warm press forming is performed on the pre-formed semi-article thus molded by heating it to a supercooled liquid temperature range.

**[0036]** As shown in Fig. 1A, the die casting apparatus 1 is schematically configured by appropriately arranging a melting unit 2 for a metallic glass M, a die set 3, and an injection unit 4 inside a die-casting chamber 5.

**[0037]** The melting unit 2 is configured by including a crucible 2a and a heater 2b arranged around the crucible 2a so that the metallic glass M inside the crucible 2a can be heated and melted.

**[0038]** The die set 3 is configured by including a die 3a and a sleeve 3b. The die 3a is provided with a cavity A for molding a pre-formed semi-article M1. The sleeve 3b communicates with the cavity A via a runner.

**[0039]** The injection unit 4 is composed by including a plunger 4a and a piston 4b. The plunger 4a reciprocates inside the sleeve 3b; and the piston 4b is a drive source of the plunger 4a.

**[0040]** The pre-forming by die casting in the method of molding a metallic glass according to this embodiment is performed as follows. The metallic glass M which has been melted inside the crucible 2a is filled into the sleeve 3b, and then is filled into the cavity A by pressurization. As a result, the pre-formed semi-article M1 can be molded.

**[0041]** Additionally, as shown in Fig. 1B, the warm pressing apparatus 10 is configured by including an upper die 10a and a lower die 10b, and is configured in a manner where a cavity B is formed by mold-clamping of the both dies 10a and 10b.

**[0042]** The warm press forming in the method of forming a metallic glass according to this embodiment is performed by heating the pre-formed semi-article M1 to the supercooled liquid temperature range, mounting it in the cavity B of the warm pressing apparatus 10, and then,

press-forming it. As a result, a formed article M2 can be formed.

**[0043]** More specifically, when the pre-formed semi-article M1 molded in the die casting apparatus 1 is warm pressed after having been transferred to the warm pressing apparatus 10, surface defects (casting defects) such as casting blowholes are filled by means of viscous flow (refer to Fig. 2A), whereby a molded article M2 (refer to Fig. 2B) free from the surface defects can be obtained.

**[0044]** As described above, the method of forming a metallic glass according to this embodiment reduces complication of considering a casting technique, which is acquired by those skilled in the art based on repetitive experiences, as to, for example, providing appropriate numbers of runners, air vents, and overflows in appropriate positions. For this reason, the method provides a convenience of having the surface defects cancelled by the warm pressing even if more or less of the surface defects have remained. Accordingly, structures of dies can also be simple, whereby reduction in cost for dies can be pursued eventually.

**[0045]** Note that the die-casting and the warm pressing may be performed respectively in different chambers as shown in Figs. 1A and 1B, or may be semicontinuously performed in the same chamber.

**[0046]** Additionally, in this embodiment, the warm pressing apparatus 10 may be configured in a manner where a gap in the cavity B becomes 1 mm or less.

**[0047]** According to the configuration as described above of the warm pressing apparatus 10, as shown in Fig. 2B, the formed article M2 is formed by the warm pressing dies 10a and 10b provided with the cavity B whose gap becomes 1 mm or less. Accordingly, finishing forming, in which viscous flow specific to the metallic glass M is utilized, is sufficiently accomplished. As a result, the configuration can be also suitable for a formed article having a nonuniform-wall or a thin-wall having in three-dimension molded article, and a formed article having a complicated shape.

**[0048]** Additionally, in this embodiment, the pre-forming by die casting may be configured to be performed by ventilating an inert gas.

**[0049]** Fig. 3 indicates a method of carrying out the pre-forming by die casting by ventilating an inert gas G into an inside of the die-casting chamber 5 in Fig. 1A.

**[0050]** That is, the die-casting apparatus 1 is configured by including an inert gas inlet 6 and an inert gas outlet 7 respectively in appropriate locations of the die-casting chamber 5. The die-casting apparatus 1 performs the pre-forming by ventilating the inert gas G into the inside of the die-casting chamber 5 through the inlet 6.

**[0051]** Here, helium, nitrogen, argon or the like is selected as the inert gas G.

**[0052]** The pre-formed semi-article M1 is pushed and released from the die set 3 by an extrusion pin (not illustrated). The pre-formed semi-article M1 is dropped to, and stored in, a repository prepared in a lower place of

the inside of the die-casting chamber 5.

**[0053]** According to the configuration of the die casting apparatus 1 as described above, there is no need of reducing a pressure inside the die-casting chamber 5 to a high vacuum level every time the metallic glass M is melted, for which oxidization at the time of melting is not favorable. Thereby, simplification of the processes can be pursued.

**[0054]** At this time, the metallic glass M may be introduced to the inside of the die-casting chamber 5 via a preliminarily evacuated antechamber (not illustrated). In the configuration as described above of the die casting apparatus 1, installation and the pre-forming can be continuously performed on the metallic glass M.

**[0055]** Additionally, the metallic glass M used in the die-casting may be configured to be melted by using a YAG laser L as a heat source in this embodiment.

**[0056]** Fig. 4 shows an example where the YAG laser L is used as a melting heat source for the metallic glass M.

**[0057]** An example where the heater 2b is provided inside the die-casting chamber 5 is shown in Fig. 1B. However, by providing the melting heat source outside the die-casting chamber 5, a volume of the die-casting chamber 5 can be made smaller and an amount of ventilation of the inert gas can be saved.

**[0058]** In Fig. 4, a component indicated by reference numeral 8 is an inlet window for the YAG laser L and is composed of a transparent glass, and a component indicated by reference numeral 9 is a sealing member.

**[0059]** Here, one reason for using the YAG laser L as the melting heat source for the metallic glass M is that high-energy density beams can be radiated, from an outside of the die-casting chamber 5 via the inlet window 8 made of a transparent silica glass or the like, into the die-casting chamber 5 blocked from the outside air.

**[0060]** Furthermore, also in the case of simultaneously carrying out the pre-forming by using a plurality of the die casting apparatuses 1, the use of the YAG laser L is advantageous. This is because it is possible to efficiently carry out melting in a plurality of locations by the YAG laser L branching from a single laser oscillation apparatus by means of a plurality of optical fibers.

**[0061]** Additionally, the warm press forming is performed by using the warm pressing apparatus 10 shown in Fig. 1B, and heating the pre-formed semi-article M1 to the supercooled liquid temperature range in atmosphere. As a result, finishing in which the viscous flow specific to the metallic glass M is utilized can be accomplished.

**[0062]** The heating to the supercooled liquid temperature range may be configured to be performed on the pre-formed semi-article M1 set in a die inside of which a heater is provided. The warm pressing apparatus 10 having this configuration is shown in Fig. 5.

**[0063]** The warm pressing apparatus 10 is configured of the upper die 10a and the lower die 10b inside each of which cartridge heaters H are provided, as shown in Fig. 5.

**[0064]** According to the warm pressing apparatus 10 having the configuration as described above, the pre-formed semi-article M1 can be heated at the time of the warm press forming, and becomes less likely to be influenced by an ambient temperature. For this reason, it becomes possible to continuously carry out the warm pressings only by simple opening and closing operations of the upper die 10a or the lower die 10b.

**[0065]** Here, the warm pressing may be performed by selecting the inert gas as an ambient atmosphere, or the warm pressing may be performed in atmosphere. In the case of carrying out the warm pressing in atmosphere, an oxide film is formed on a surface of a molding subject. However, the oxide coating film becomes a protective film to prevent oxidation penetration into an inside of the molding subject, and also does not cause crystallization from the surface, by completing the forming until the forming subject crystallizes in a supercooled liquid temperature range.

**[0066]** Additionally, in this embodiment, the warm press forming may be configured to be performed as follows. A powder film P which blocks atmosphere is applied onto the pre-formed semi-article M1, and then the pre-formed semi-article M1 is heated to a supercooled liquid temperature range. The pre-formed semi-article M1 in this case is shown in Fig. 6.

**[0067]** Here, the powder film P is obtained by applying powder onto a surface of the pre-formed semi-article M1. Note that the present invention is not limited to the case of using BN (boron-nitride) as the powder film P. The present invention is also applicable to the case of using a powder film capable of achieving distribution of heat-resisting particles, such as high-density carbon powder or molybdenum disulfide ( $\text{MoS}_2$ ).

**[0068]** Additionally, it is not necessary to limit the present invention to the case of using a spray as a method of the application. The present invention is also applicable to the case of using immersion or brush coating.

**[0069]** According to the configuration as described above, the powder film P exists between each of the dies and the pre-formed semi-article M1, and functions as reducing surface friction during the forming. As a result, viscous flow of the pre-formed semi-article M1 is facilitated, whereby the more smooth press forming can be performed.

**[0070]** Additionally, in this embodiment, the warm press forming may be configured to be performed by heating the pre-formed semi-article M1 to the supercooled liquid temperature range after preparing a surface roughness of the pre-formed semi-article M1 to be in a range of equal to or more than  $0.1 \mu\text{m}$  and equal to or less than  $5 \mu\text{m}$  in arithmetic average roughness (Ra). The pre-formed semi-article M1 in this case is shown in Fig.7.

**[0071]** Here, the pre-formed semi-article M1 has the surface roughness prepared to be in a range of equal to or more than  $0.1 \mu\text{m}$  and equal to or less than  $5 \mu\text{m}$  in arithmetic average roughness (Ra) by applying a sand

blasting treatment onto a surface m.

**[0072]** Note that the present invention is not limited to the case of using the sand blasting for preparing the surface roughness. The present invention is also applicable to the case of using shot blasting in which another projected material is utilized, mechanical grinding, chemical polishing or the like.

**[0073]** Additionally, limiting the surface roughness is because of the following reasons. If the surface roughness Ra is less than  $0.1 \mu\text{m}$ , an effect of reducing a contact area between a die (for example, the upper die 10a) and the pre-formed semi-article M1 becomes insufficient, and also an effect of reducing friction does not occur.

**[0074]** On the contrary, if the surface roughness Ra exceeds  $5 \mu\text{m}$ , although the friction is considerably reduced, there is a possibility that locations difficult to be filled in by means of the viscous flow may remain depending on a shape of the pre-formed semi-article M1.

**[0075]** According to the above described configuration, the surface m of the pre-formed semi-article M1 is prepared so as to have the surface roughness within the predetermined range. The surface m functions as reducing the friction by reducing a contact area between the die (for example, the upper die 10a) and the pre-formed semi-article M1, and of facilitating the viscous flow of the pre-formed semi-article M1.

**[0076]** Large surface defects of the pre-formed semi-article M1 gradually become smaller by means of the viscous flow along with the progress of the forming, and become completely flat at the time when the forming is completed. Accordingly, there is no possibility that these surface defects adversely affect surface quality of the formed article M2 (refer to Fig. 2B).

**[0077]** According to the method of forming a metallic glass according to this embodiment, a process of warm press forming is performed on the metallic glass being heated to the supercooled liquid temperature range continuously after a process of performing pre-forming on the metallic glass by die casting. Accordingly, material surrounding surface defects remaining on the surface of the pre-formed semi-article at the time of casting is filled into the surface defects by means of the viscous flow, and the surface defects are buried, whereby the defects can be cleared away.

**[0078]** In other words, according to the method of forming a metallic glass according to this embodiment, surface defects remaining on the surface of the pre-formed semi-article M1 having been molded by die casting can be cleared away at the time of successively performing the warm press forming of the metallic glass being heated to a supercooled liquid temperature range. This makes it possible to provide a method of forming a metallic glass, which is capable of forming a formed article in which surface defects are not generated while maintaining an amorphous state of the metallic glass.

**[0079]** Moreover, according to the method of forming a metallic glass according to this embodiment, the surface defects remaining on the surface of the pre-formed

semi-article M1 can be cleared away at the time of successively performing the warm press forming. Accordingly, the designing of dies becomes easier, and at the same time, a post process of cutting and removing excess portions after the forming is reduced. This makes it possible to provide a method of forming a metallic glass, which is capable of forming a formed article having high measurement accuracy by simplified processes.

**[0080]** Furthermore, according to the method of forming a metallic glass according to this embodiment, warm press forming is performed along with viscous flow of the metallic glass. This makes it possible to provide a method of forming a metallic glass, which is capable of easily forming a formed article having a thin-wall or nonuniform-wall, and a formed article having a complicated shape.

**[0081]** According to the method of molding a metallic glass according to this embodiment, a formed article is formed by the warm pressing dies 10a and 10b provided with the cavity B whose gap becomes 1 mm or less. Accordingly, finishing forming in which viscous flow specific to the metallic glass is utilized is sufficiently accomplished. As a result, the method can be also suitable for a formed article having a nonuniform-wall or thin-wall in three dimension and a formed article having a complicated shape.

**[0082]** According to the method of forming a metallic glass according to this embodiment, there is no need of depressing an ambient atmosphere for pre-forming by die casting to a high vacuum level every time the metallic glass is melted.

**[0083]** According to the method of forming a metallic glass according to this embodiment, the YAG laser L is used. For this reason, high-energy density beams are radiated from an outside of the die-casting chamber 5 into the die-casting chamber 5 which is blocked from the outside air. Thereby, the metallic glass M can be melted in the die-casting chamber 5. Moreover, even in the case of simultaneously carrying out the pre-forming by using a plurality of the die casting apparatuses 1, the metallic glass M in a plurality of the die-casting chambers 5 can be simultaneously melted by branching the YAG laser L from a single laser oscillation apparatus by means of a plurality of the optical fibers.

**[0084]** In other words, according to the method of forming a metallic glass according to this embodiment, the melting heat source for the metallic glass M can be set up outside of the die-casting chamber 5 by using the YAG laser L. For this reason, a volume of the die-casting chamber 5 can be made smaller and an amount of ventilation of the inert gas can be saved. At the same time, the metallic glasses M in a plurality of the die-casting chambers 5 can be simultaneously melted by branching the YAG laser L by means of a plurality of the optical fibers. Accordingly, improvement of fabrication can be pursued.

**[0085]** According to the method of forming a metallic glass according to this embodiment, warm press forming is performed on the pre-formed semi-article M1 heated to the supercooled liquid temperature range in atmos-

phere. For this reason, finishing in which viscous flow specific to the metallic glass is used can be accomplished.

**[0086]** According to the method of molding a metallic glass according to this embodiment, the warm pressing can be continuously performed only by simple opening and closing operations of any one of an upper die and a lower die with less influence by an ambient temperature.

**[0087]** According to the method of forming a metallic glass according to this embodiment, the powder film P exists between each of the dies and the pre-formed semi-article M1, and functions as reducing surface friction during the forming. As a result, viscous flow of the pre-formed semi-article M1 can be facilitated.

**[0088]** According to the method of forming a metallic glass according to this embodiment, a surface of the pre-formed semi-article M1 is prepared to be in a range of equal to or more than 0.1  $\mu\text{m}$  and equal to or less than 5  $\mu\text{m}$ . Accordingly, a contact area between each of the dies 10a and 10b, and the pre-formed semi-article M1 at the time of the warm pressing becomes smaller, whereby friction therebetween is reduced. As a result, viscous flow of the pre-formed semi-article M1 at the time of the warm pressing is facilitated.

**[0089]** Additionally, the pre-formed semi-article M1 may be one having the powder film P applied on a surface, whose surface roughness has been prepared. In this case, formation of the powder film P is favorable, and the viscous flow of the pre-formed semi-article at the time of the warm pressing is further facilitated.

**[0090]** According to the method of forming a metallic glass according to this embodiment, after the pre-forming by die casting has been performed by using a zirconium-based metallic glass, the pre-formed semi-article M1 thus obtained is heated to a supercooled temperature range, and then warm press forming is applied to the pre-formed semi-article M1. Accordingly, at the time of the warm press forming, finishing forming in which viscous flow in an extremely wide supercooled temperature range specific to the zirconium-based metallic glass is advantageously utilized can be sufficiently accomplished. Accordingly, surface defects remained on the surface of the pre-formed semi-article at the time of casting can be effectively cleared away.

**[0091]** In other words, according to the method of forming a metallic glass according to this embodiment, at the time of the warm press forming, the finishing forming in which the viscous flow in the extremely wide supercooled temperature range specific to the zirconium-based metallic glass is advantageously utilized can be sufficiently accomplished. As a result, the surface defects remained on the surface of the pre-formed semi-article M1 at the time of casting can be more effectively cleared away. Thereby, a formed article in which surface defects are not generated can be formed while maintaining an amorphous state of the zirconium-based metallic glass.

**[0092]** In Figs. 8A and 8B, evaluation results regarding formed articles made of metallic glass according to Ex-

amples 1 to 9 and Comparative Examples 1 to 5 are shown.

**[0093]** The formed articles made of metallic glass according to Examples 1 to 9 were formed by the above described method of forming a metallic glass according to the first embodiment. Specifically, each of the formed articles made of metallic glass according respectively to Examples 1 to 9 was formed in the following manner. After pre-forming by die casting was performed on the metallic glass M, the pre-formed semi-article M1 thus obtained was heated to the supercooled liquid temperature range and then the warm press forming was applied to the pre-formed semi-article M1. Die casting conditions and warm pressing conditions in respective Examples 1 to 9 are shown in Figs. 8A and 8B.

**[0094]** On the other hand, the formed article made of metallic glass according to Comparative Example 1 was formed by a method of forming a metallic glass only by die casting. The formed article made of metallic glass according to Comparative Example 2 was formed by a method of forming a metallic glass in which warm pressing was attempted by using a material previously formed into a plate by melt-forging. The formed article made of metallic glass according to Comparative Example 3 was formed by a method of forming a metallic glass only by permanent mold casting. The formed article made of metallic glass according to Comparative Example 4 was formed by a method of forming a metallic glass only by high-pressure injection molding. The formed article made of metallic glass according to Comparative Example 5 was formed by a method of forming a metallic glass only by melt-forging. Note that forming conditions in Comparative Examples 1 to 5 are also shown in Figs. 8A and 8B.

**[0095]** Note that the metallic glass used in the Examples 1 to 9 and Comparative Examples 1 to 5 is a zirconium-based metallic glass.

**[0096]** Note that, as shown in Figs. 8A and 8B, evaluation was given of effects regarding "minimum wall thickness of finished article by forming," "surface roughness of finished article," "finished shape (degree of filling)," "presence or absence of surface defect" and "whether or not finished article maintains amorphous state."

**[0097]** Here, "finished shape (degree of filling)" is indicated by "O" in a case where a difference of a measured weight in the finished shape from a weight which can be previously calculated based on a volume and a specific gravity was minus 0.5 % or better, or is indicated by "X" in a case where the weight difference exceeding 0.5 % occurred.

**[0098]** Additionally, "presence or absence of surface defect" was evaluated by visually determining whether or not there were any points deteriorating a shape of the finished article and a surface state as compared to a designed shape of a die cavity.

**[0099]** Moreover, "determination on whether or not finished article maintains amorphous state" is indicated by "O" in a case where it was determined that an amorphous state was maintained based on a result of analyzing the

finished article by an X-ray diffraction method, or is indicated by "X" in a case where crystallization occurred without the amorphous state being maintained.

**[0100]** It is clear from Figs. 8A and 8B, Examples 1 to 9 all cleared evaluation items for all of the effects, whereas Comparative Examples 1 to 5 all had "X" in finished shape (degree of filling), and "present" in presence or absence of surface defect. Therefore, it can be understood how Examples 1 to 9 are excellent.

**[0101]** More specifically, each of Examples 1 to 9 all had "minimum thicknesses of finished article" smaller than "molded thicknesses" of the corresponding pre-formed semi-article, and had "surface roughness" of the finished article smaller than that at the time of warm pressing. As a result, it can be understood that, by performing the warm press forming, material surrounding surface defects remained on surfaces of the pre-formed semi-articles at the time of casting is filled into the surface defects by means of the viscous flow, the surface defects are buried, and the defects can be cleared away.

**[0102]** Additionally, each of Examples 1 and 2 is a three-dimensional cabinet having uniform wall thickness and each of Examples 3 to 9 is a three-dimensional cabinet having nonuniform wall thickness. They, however, all resulted in having cleared the evaluation items for all of the effects. Accordingly, it can be understood that the method of forming a metallic glass according to this embodiment is capable of easily forming a formed article having a thin-wall or a nonuniform-wall in three dimension, and a formed article having a complicated shape.

**[0103]** Additionally, ambient atmospheres at the time of the die-cast molding were: vacuum in Example 1; nitrogen gas in Examples 2 and 6; argon gas in Examples 3, 5 and 7 to 9; and helium gas in Example 4. These examples, however, all resulted in having cleared the evaluation items for all of the effects. Accordingly, it can be understood that all of these inert gasses are applicable.

**[0104]** Additionally, ambient atmospheres at the time of the warm press forming were nitrogen gas in Examples 1 to 7 and atmosphere in Examples 8 and 9. These examples, however, all resulted in having cleared the evaluation items for all of the effects. Accordingly, it can be understood that any one of inert gasses which are represented by nitrogen gas and atmosphere is applicable to the warm press forming.

## INDUSTRIAL APPLICABILITY

**[0105]** As described above, according to the present invention, it is possible to provide a method of forming a metallic glass. The method of forming a metallic glass is capable of forming a formed article in which no surface defects are generated while maintaining an amorphous state of the metallic glass. The method is also capable of forming a formed component with high measurement accuracy by simplified processes in which dies having simple structures are used. The method is further capa-



ble of easily forming the metallic glass into a thin-wall or nonuniform-wall formed article and a formed article having a complicated shape.

### Claims

1. A method of forming a metallic glass to obtain a formed article (M2), comprising the steps of:

molding a metallic glass into a pre-formed semi-article (M1) by performing pre-forming by die casting; and

heating the pre-formed semi-article (M1) to a supercooled liquid temperature range of the metallic glass and performing warm press forming on the pre-formed semi-article (M1) by means of dies (10a, 10b) having a cavity receiving the pre-formed semi-article (M1) to obtain the formed article (M2), whereby viscous flow fills in surface defects remaining on the surface of the pre-formed semi-article after the die casting.

2. The method of forming a metallic glass according to claim 1, wherein the formed article (M2) obtained by performing the warm press forming has a thickness of 1 mm or less.

3. The method of forming a metallic glass according to claim 1 or 2, wherein the pre-forming by the die casting is performed while ventilating with an inert gas.

4. The method of forming a metallic glass according to any one of claims 1 to 3, wherein the metallic glass is melted by using a YAG laser as a heat source in the pre-forming by the die casting.

5. The method of forming a metallic glass according to any one of claims 1 to 4, wherein the warm press forming is performed with heating of the pre-formed semi-article (M1) to the supercooled liquid temperature range in atmosphere.

6. The method of forming a metallic glass according to claim 5, wherein the heating to the supercooled liquid temperature range is performed by setting the pre-formed semi-article into the dies (10a, 10b), a heat being provided inside of the respective dies (10a, 10b).

7. The method of forming a metallic glass according to any one of claims 1 to 6, wherein the warm press forming is performed with heating of the pre-formed semi-article (M1) to the supercooled liquid temperature range after a powder film for blocking atmosphere is applied to the pre-formed semi-article.

8. The method of forming a metallic glass according to

any one of claims 1 to 6, wherein the warm press forming is performed with heating of the pre-formed semi-article to the supercooled liquid temperature range after the surface roughness of the pre-formed semi-article is controlled to be in a range of 0.1  $\mu\text{m}$  or more and 5  $\mu\text{m}$  or less in arithmetic average roughness.

9. The method of forming a metallic glass according to any one of claims 1 to 8, wherein the metallic glass is a zirconium-based metallic glass.

### Patentansprüche

1. Verfahren zum Formen eines Metallglases zum Erhalt eines Formgegenstands (M2), das folgende Schritte umfasst:

das Formen eines Metallglases zu einem vorgeformten Halbzeug (M1) durch das Durchführen des Vorformens mittels Spritzgießen; und das Erhitzen des vorgeformten Halbzeugs (M1) zum Erreichen des unterkühlten Flüssigkeitstemperaturbereichs des Metallglases und das Durchführen von Heißpressformen des vorgeformten Halbzeugs (M1) durch Druckgießformen (10a, 10b) mit einer Aushöhlung, die das vorgeformte Halbzeug (M1) aufnimmt, um den Formgegenstand (M2) zu erhalten, wobei ein viskoser Strom Oberflächenschäden auffüllt, die auf der Oberfläche des vorgeformten Halbzeugs nach dem Spritzgießen verbleiben.

2. Verfahren zum Formen eines Metallglases nach Anspruch 1, worin der Formgegenstand (M2), der durch das Durchführen des Heißpressformens erhalten wird, eine Dicke von 1 mm oder weniger aufweist.

3. Verfahren zum Formen eines Metallglases nach Anspruch 1 oder 2, worin das Vorformen durch das Spritzgießen unter Ventilation mit einem inerten Gas erfolgt.

4. Verfahren zum Formen eines Metallglases nach einem der Ansprüche 1 bis 3, worin das Metallglas bei dem Vorformen mittels Spritzgießen unter Anwendung eines YAG-Lasers als Wärmequelle geschmolzen wird.

5. Verfahren zum Formen eines Metallglases nach einem der Ansprüche 1 bis 4, worin das Heißpressformen unter Erhitzen des vorgeformten Halbzeugs (M1) unter atmosphärischem Druck auf den Temperaturbereich einer unterkühlten Flüssigkeit erfolgt.

6. Verfahren zum Formen eines Metallglases nach Anspruch 5, worin das Erhitzen auf den unterkühlten

Flüssigkeitstemperaturbereich durch das Einlegen des vorgeformten Halbzeugs in die Druckgießformen (10a,10b) erfolgt, wobei in den jeweiligen Druckgießformen (10a, 10b) Wärme bereitgestellt ist.

7. Verfahren zum Formen eines Metallglases nach einem der Ansprüche 1 bis 6, worin das Heißpressformen unter Erhitzen des vorgeformten Halbzeugs (M1) auf einen unterkühlten Flüssigkeitstemperaturbereich erfolgt, nachdem ein Pulverfilm auf das vorgeformte Halbzeug aufgebracht wurde, um die umgebende Atmosphäre abzublocken.
8. Verfahren zum Formen eines Metallglases nach einem der Ansprüche 1 bis 6, worin das Heißpressformen unter Erhitzen des vorgeformten Halbzeugs auf den unterkühlten Flüssigkeitstemperaturbereich erfolgt, nachdem die Oberflächenrauigkeit des vorgeformten Halbzeugs so gesteuert wurde, dass das arithmetische Mittel der Rauigkeit in einem Bereich von 0,1  $\mu\text{m}$  oder mehr und 5  $\mu\text{m}$  oder weniger liegt.
9. Verfahren zum Formen eines Metallglases nach einem der Ansprüche 1 bis 8, worin das Metallglas ein Metallglas auf Zirkoniumbasis ist.

#### Revendications

1. Procédé de formation d'un verre métallique pour obtenir un article formé (M2), comprenant les étapes de:
  - mouler un verre métallique en un semi-article préformé (M1) en exécutant le préformage par moulage sous pression; et
  - chauffer le semi-article préformé (M1) à une plage de température de liquide super-refroidi du verre métallique et exécuter un formage sous pression à chaud sur le semi-article préformé (M1) par des matrices (10a, 10b) ayant une cavité recevant le semi-article préformé (M1) pour obtenir l'article formé (M2), où un écoulement visqueux remplit des défauts de surface subsistant sur la surface du semi-article préformé après le moulage sous pression.
2. Procédé de formation d'un verre métallique selon la revendication 1, dans lequel l'article formé (M2) obtenu en exécutant le formage sous pression à chaud à une épaisseur de 1 mm ou moins.
3. Procédé de formage d'un verre métallique selon la revendication 1 ou 2, dans lequel le pré-formage par le moulage sous pression est exécuté tout en ventilant avec un gaz inerte.

4. Procédé de formage d'un verre métallique selon l'une quelconque des revendications 1 à 3, dans lequel le verre métallique est amené à fondre en utilisant un laser YAG comme une source de chaleur lors du pré-formage par le moulage sous pression.
5. Procédé de formage d'un verre métallique selon l'une quelconque des revendications 1 à 4, dans lequel le formage sous pression à chaud est exécuté en chauffant le semi-article préformé (M1) à la plage de température liquide super-refroidie dans l'atmosphère.
6. Procédé de formage d'un verre métallique selon la revendication 5, dans lequel le chauffage à la plage de température liquide super-refroidie est exécuté en plaçant le semi-article préformé dans des matrices (10a, 10b), une chaleur étant réalisée à l'intérieur des matrices respectives (10a, 10b).
7. Procédé de formage d'un verre métallique selon l'une quelconque des revendications 1 à 6, dans lequel le formage sous pression à chaud est exécuté en chauffant le semi-article préformé (M1) à la plage de température liquide super-refroidie après qu'un film en poudre pour bloquer l'atmosphère a été appliqué au semi-article préformé.
8. Procédé de formage d'un verre métallique selon l'une quelconque des revendications 1 à 6, dans lequel le formage sous pression à chaud est exécuté en chauffant le semi-article préformé à la plage de température liquide super-refroidie après que la rugosité de surface du semi-article préformé a été commandée pour être dans une plage de 1,0  $\mu\text{m}$  ou plus, et de 5  $\mu\text{m}$  ou moins dans une rugosité moyenne arithmétique.
9. Procédé de formage d'un verre métallique selon l'une quelconque des revendications 1 à 8, dans lequel le verre métallique est un verre métallique à base de zirconium.

FIG. 1A

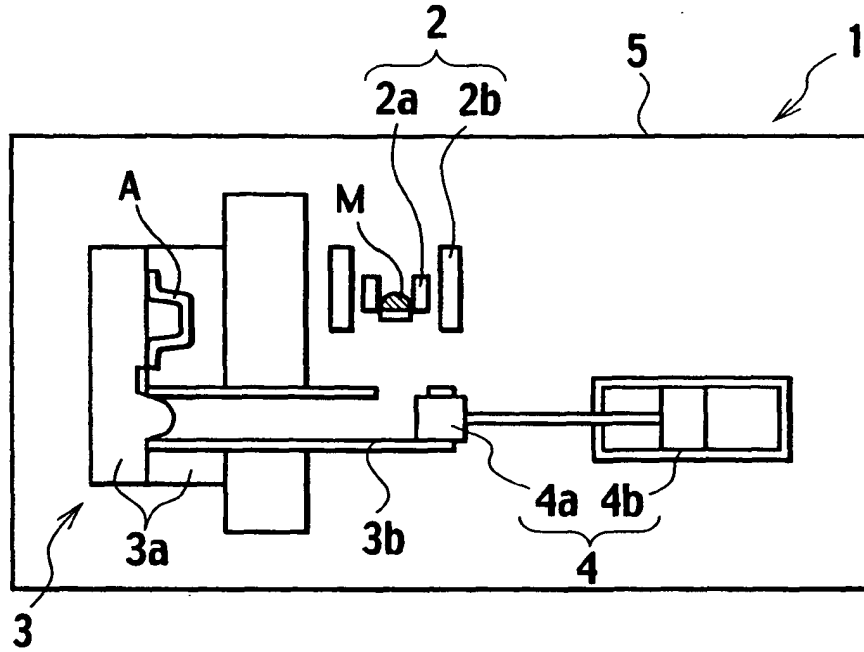

FIG. 1B

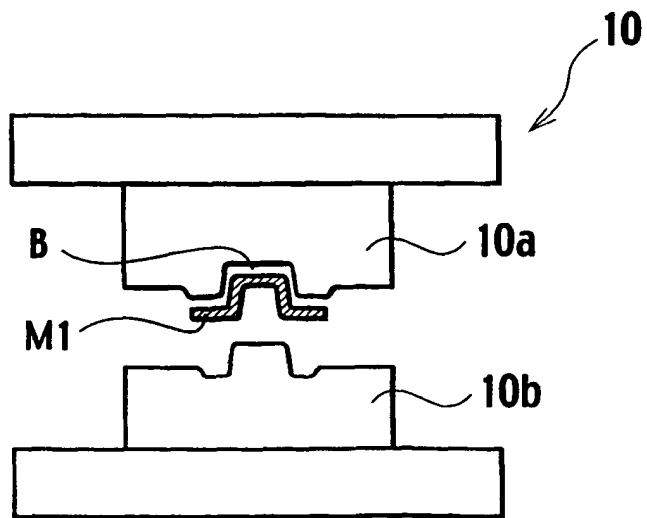

FIG. 2A

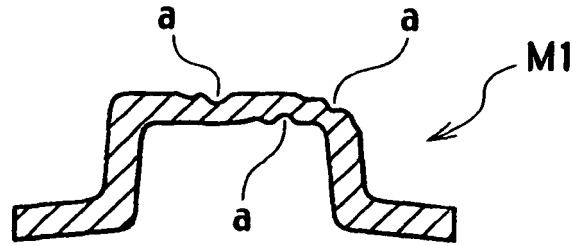

FIG. 2B

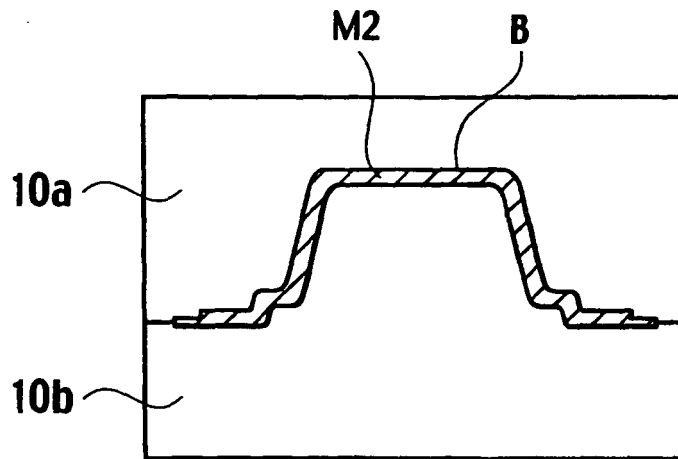

FIG. 3

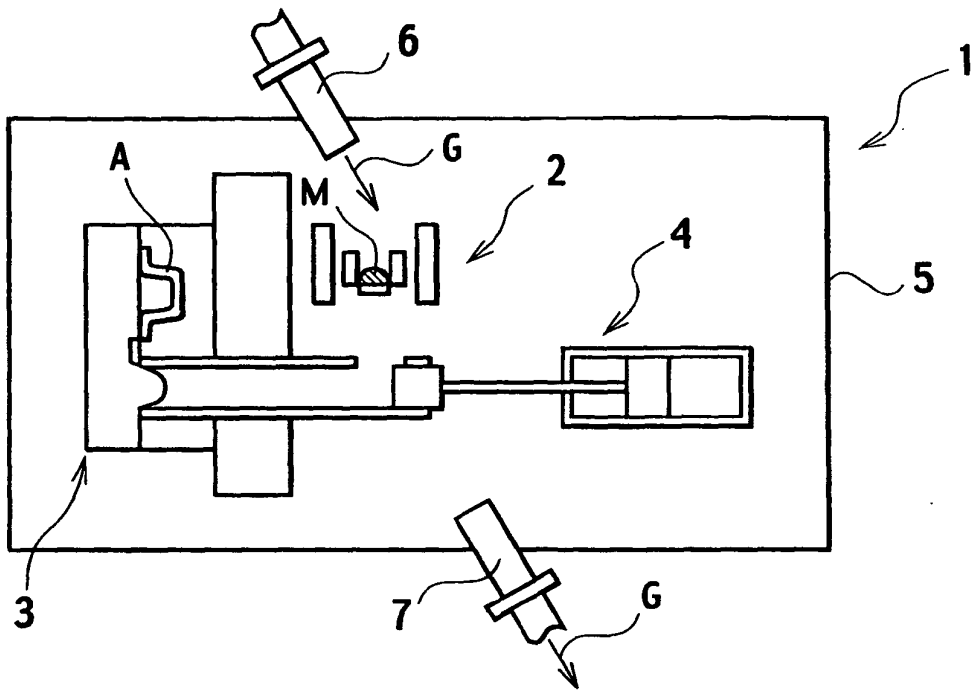

FIG. 4

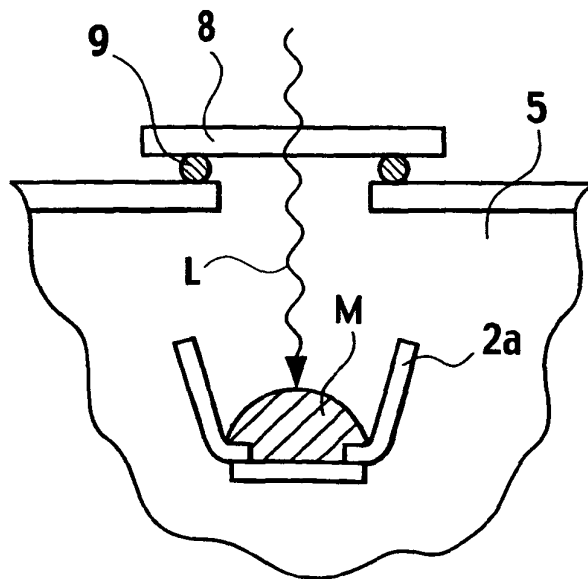

FIG. 5

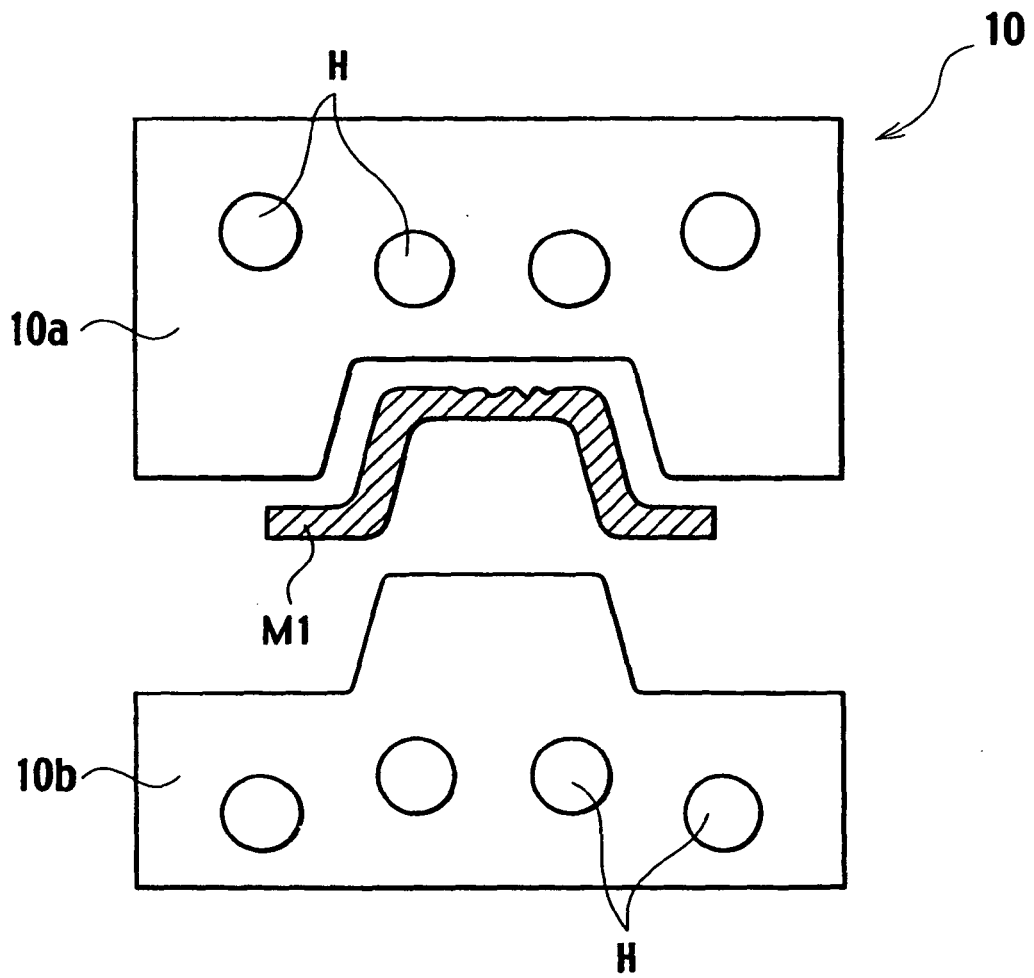

FIG. 6

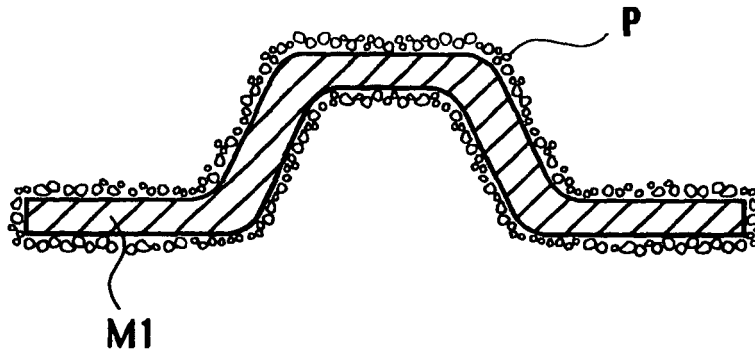
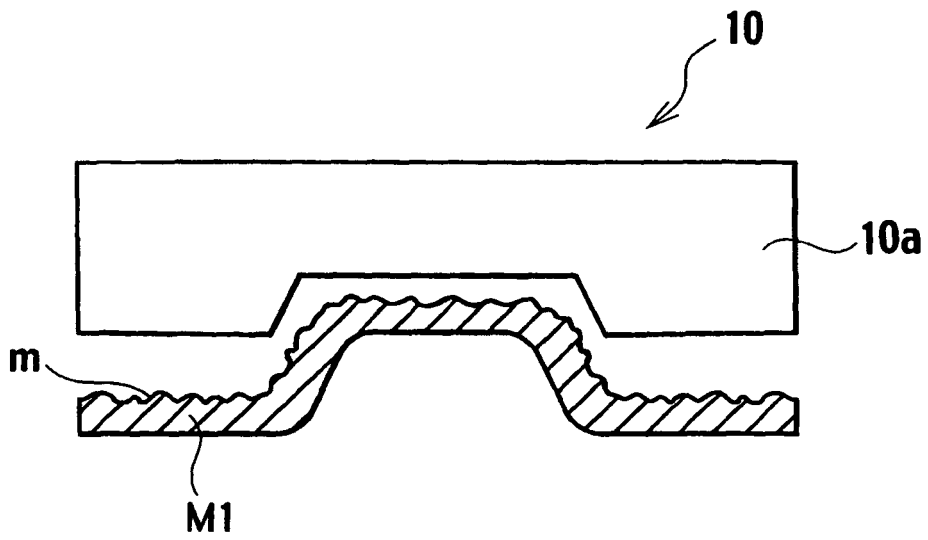

FIG. 7



(CONTINUE TO FIG. 8B)

FIG. 8A

	PRE-FORMING	MELTING METHOD	MELTING TEMPERATURE (°C)	AMBIENT ATMOSPHERE	CASTING PRESSURE (kg/cm <sup>2</sup> )	INJECTION SPEED (m/s)	CASTING THICKNESS (mm)	FINISHING FORMING	DIE HEATING	SURFACE ROUGHNESS (μm)
EXAMPLE 1	DIE CASTING	HIGH FREQUENCY INDUCTION HEATING	1,200	VACUUM	800	1.6	0.7	WARM PRESSING	BUILT-IN HEATER	0.07
EXAMPLE 2	DIE CASTING	HIGH FREQUENCY INDUCTION HEATING	1,250	N <sub>2</sub> VENTILATION	700	1.4	1.1	WARM PRESSING	BUILT-IN HEATER	0.4
EXAMPLE 3	DIE CASTING	YAG LASER	NOT MEASURABLE	Ar VENTILATION	800	1.4	0.7	WARM PRESSING	BUILT-IN HEATER	0.3
EXAMPLE 4	DIE CASTING	YAG LASER	NOT MEASURABLE	He VENTILATION	800	1.6	0.4	WARM PRESSING	BUILT-IN HEATER	0.4
EXAMPLE 5	DIE CASTING	HIGH FREQUENCY INDUCTION HEATING	1,200	Ar VENTILATION	750	1.4	1.1	WARM PRESSING	BUILT-IN HEATER	0.4
EXAMPLE 6	DIE CASTING	YAG LASER	NOT MEASURABLE	N <sub>2</sub> VENTILATION	800	1.4	0.7	WARM PRESSING	BUILT-IN HEATER	0.2
EXAMPLE 7	DIE CASTING	YAG LASER	NOT MEASURABLE	Ar VENTILATION	800	1.5	0.7	WARM PRESSING	BUILT-IN HEATER	4.9
EXAMPLE 8	DIE CASTING	YAG LASER	NOT MEASURABLE	Ar VENTILATION	800	1.5	0.5	WARM PRESSING	BUILT-IN HEATER	1.2
EXAMPLE 9	DIE CASTING	YAG LASER	NOT MEASURABLE	Ar VENTILATION	800	1.3	0.5	WARM PRESSING	BUILT-IN HEATER	0.4
COMPARATIVE EXAMPLE 1	DIE CASTING	HIGH FREQUENCY INDUCTION HEATING	NOT MEASURABLE	VACUUM	800	1.4	0.7	-	-	-
COMPARATIVE EXAMPLE 2	-	-	-	-	-	-	-	WARM PRESSING	EXTERNAL HEATER	0.4
COMPARATIVE EXAMPLE 3	METAL MOLD CASTING	HIGH FREQUENCY INDUCTION HEATING	1,200	VACUUM	-	-	2	-	-	-
COMPARATIVE EXAMPLE 4	HIGH-PRESSURE INJECTION MOLDING	HIGH FREQUENCY INDUCTION HEATING	1,200	VACUUM	-	-	0.8	-	-	-
COMPARATIVE EXAMPLE 5	MELT FORGING	ARC MELTING	1,500	VACUUM	-	-	0.9	-	-	-



FIG. 8B

AMBIENT ATMOSPHERE	POWDER FILM	MOLDING TEMPERATURE (°C)	CASTING SPEED (mm/min)	PRESSURIZING PERIOD(min)	PRESS-FORMING SHAPE	MINIMUM WALL THICKNESS OF FINISHED ARTICLE (mm)	SURFACE ROUGHNESS OF FINISHED ARTICLE Ra(μm)	FINISHED SHAPE (DEGREE OF FILLING)	PRESENCE OR ABSENCE OF SURFACE DEFECT	MAINTENANCE OF AMORPHOUS CHARACTERISTIC
N2	ABSENT	450	1	2	3D CABINET, UNIFORM WALL THICKNESS	0.6	0.05	○	ABSENT	○
N2	ABSENT	450	1	2	3D CABINET, UNIFORM WALL THICKNESS	0.5	0.04	○	ABSENT	○
N2	ABSENT	450	2	1.5	3D CABINET, NONUNIFORM WALL THICKNESS	0.5	0.05	○	ABSENT	○
N2	ABSENT	450	2	1.5	3D CABINET, NONUNIFORM WALL THICKNESS	0.3	0.05	○	ABSENT	○
N2	ABSENT	450	2	1.5	3D CABINET, NONUNIFORM WALL THICKNESS	0.8	0.04	○	ABSENT	○
N2	BN	440	1.2	2	3D CABINET, NONUNIFORM WALL THICKNESS	0.4	0.04	○	ABSENT	○
N2	ABSENT	440	1.2	2	3D CABINET, NONUNIFORM WALL THICKNESS	0.5	0.03	○	ABSENT	○
ATMOSPHERE	ABSENT	430	1.2	2	3D CABINET, NONUNIFORM WALL THICKNESS	0.3	0.06	○	ABSENT	○
ATMOSPHERE	BN	430	1.2	2	3D CABINET, NONUNIFORM WALL THICKNESS	0.3	0.05	○	ABSENT	○
-	-	-	-	-	3D CABINET, NONUNIFORM WALL THICKNESS	0.7	0.07	×	PRESENT	○
N2	ABSENT	450	1	20	TRAY	0.8	0.4	×	PRESENT	○
-	-	-	-	-	3D CABINET, UNIFORM WALL THICKNESS	1.2	0.05	×	PRESENT	×
-	-	-	-	-	3D CABINET, UNIFORM WALL THICKNESS	0.8	0.06	×	PRESENT	×
-	-	-	-	-	3D CABINET, UNIFORM WALL THICKNESS	0.9	0.07	×	PRESENT	×

CONTINUE FROM FIG. 8A

**REFERENCES CITED IN THE DESCRIPTION**

*This list of references cited by the applicant is for the reader's convenience only. It does not form part of the European patent document. Even though great care has been taken in compiling the references, errors or omissions cannot be excluded and the EPO disclaims all liability in this regard.*

**Patent documents cited in the description**

- JP HEI10296424 B [0009]
- JP 2003534925 A [0014]
- JP HEI10216920 B [0017]
- US 20020072203 A [0021]

**Non-patent literature cited in the description**

- Kinou Zairyou. June 2002, vol. 22, 5-9 [0003]
- Kinou Zairyou. July 2002, vol. 22, 5-8 [0004]
- Kinou Zairyou. June 2002, vol. 22, 26-31 [0005]