



US006607284B1

(12) **United States Patent**
Tsai

(10) **Patent No.:** **US 6,607,284 B1**
(45) **Date of Patent:** **Aug. 19, 2003**

(54) **LIGHTING STRUCTURE USED FOR DECORATING**

(75) Inventor: **Hung-Chi Tsai, GuangDong (CN)**

(73) Assignee: **Shenghui Lighting Co., Ltd., Guangdong (CN)**

(*) Notice: Subject to any disclaimer, the term of this patent is extended or adjusted under 35 U.S.C. 154(b) by 0 days.

(21) Appl. No.: **10/244,835**

(22) Filed: **Sep. 17, 2002**

(51) **Int. Cl.**⁷ **F21S 13/14**

(52) **U.S. Cl.** **362/121; 362/235; 362/249; 362/806; 362/807; 362/238; 362/250**

(58) **Field of Search** **362/121, 252, 362/807, 249, 235, 287, 418, 419, 285, 427, 250, 238**

(56) **References Cited**

U.S. PATENT DOCUMENTS

3,541,322 A	*	11/1970	Bennett	362/121
6,179,442 B1	*	1/2001	Schurle	362/252
6,203,166 B1	*	3/2001	Byers	362/121
6,497,498 B2	*	12/2002	Adams	362/252
6,511,206 B1	*	1/2003	Fan Wong	362/250

* cited by examiner

Primary Examiner—Thomas M. Sember

(74) *Attorney, Agent, or Firm*—Harrison & Egbert

(57) **ABSTRACT**

A decorative lighting structure includes a plurality of lighting tubes which are pivotally fastened end to end by a plurality of convex joints and concave joints, thereby enabling the lighting tubes to be spread out or folded so as to take various forms.

2 Claims, 8 Drawing Sheets

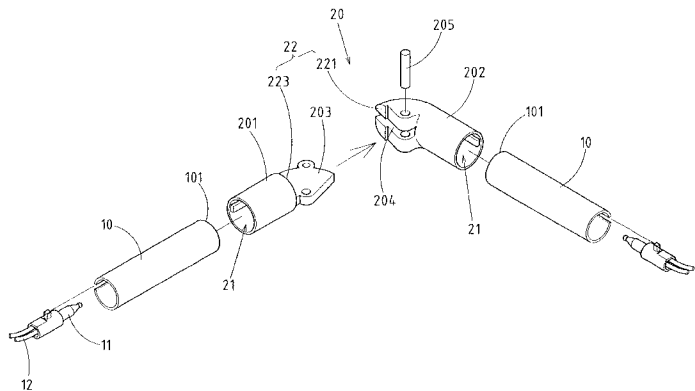
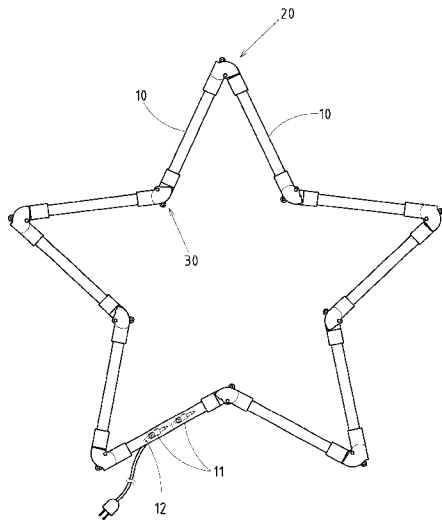

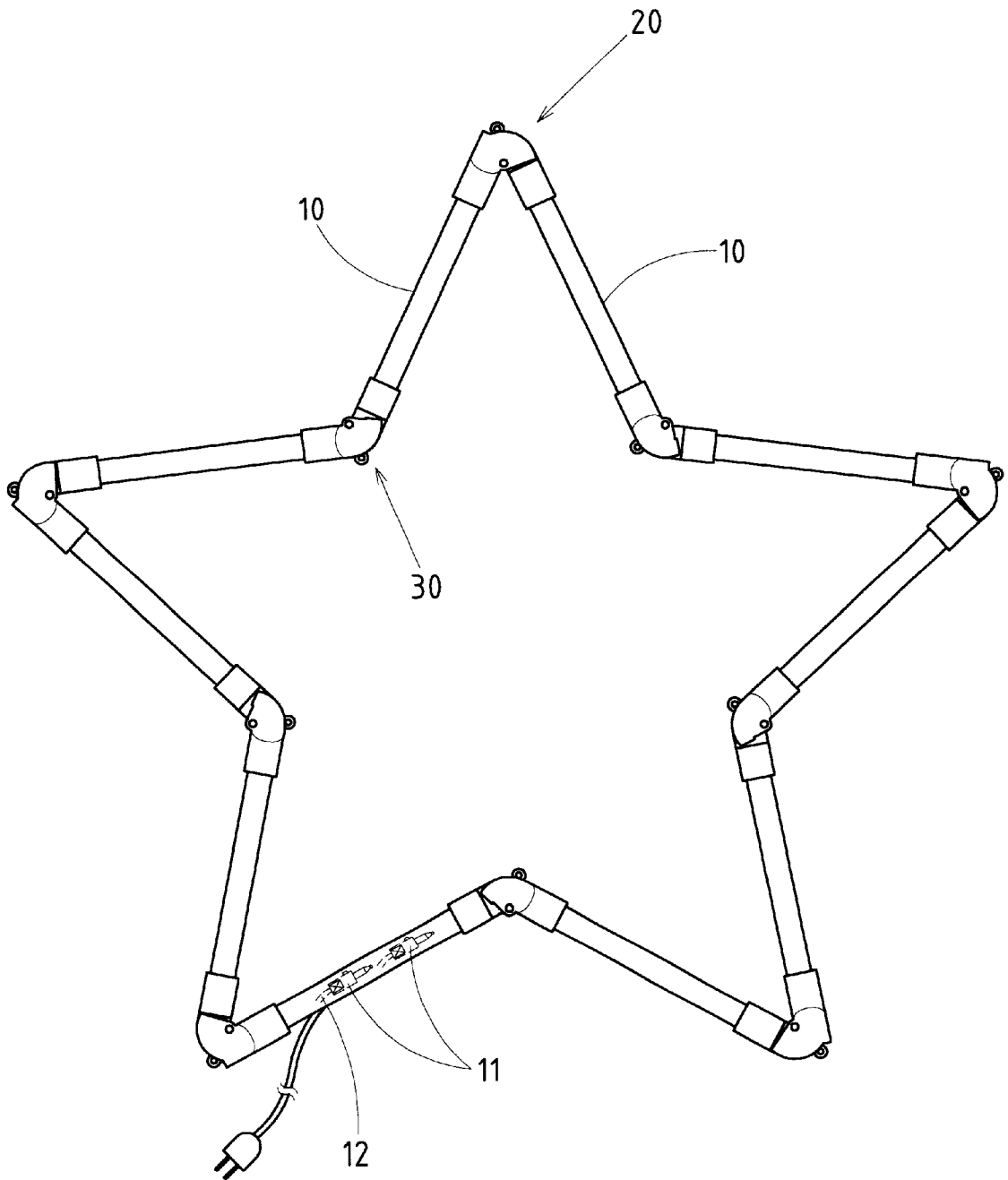

FIG.1

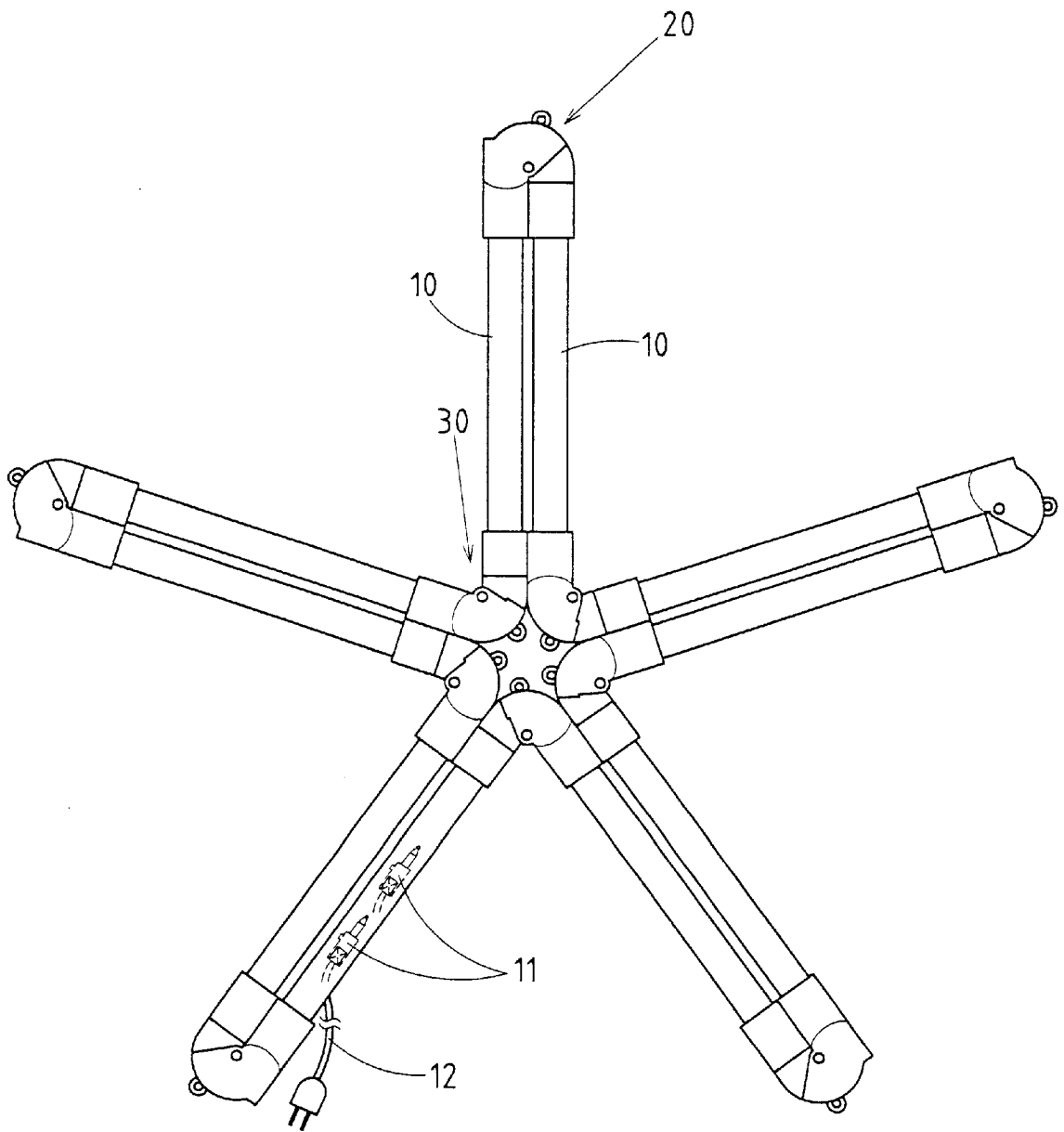

FIG. 2

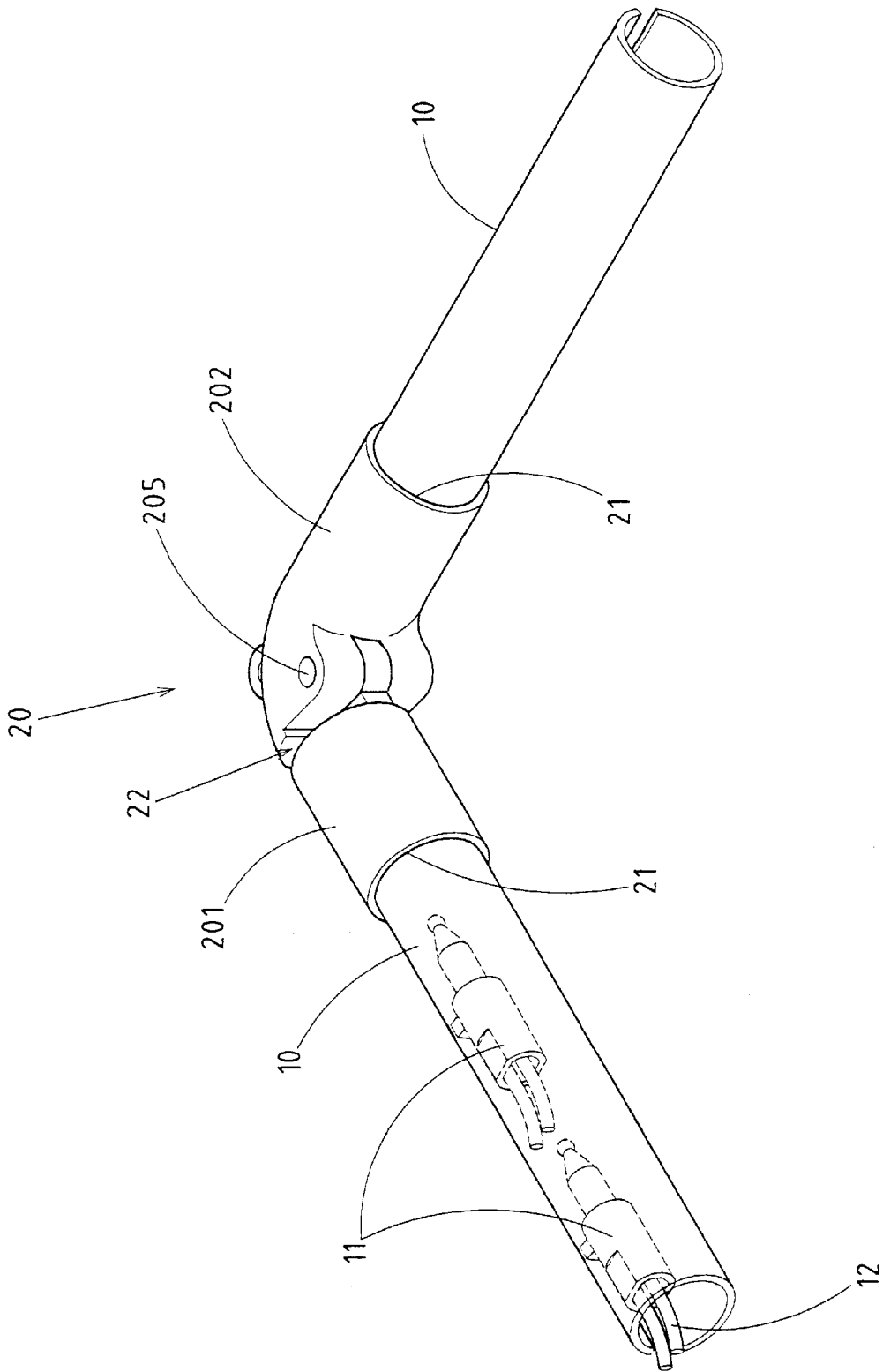

FIG. 3

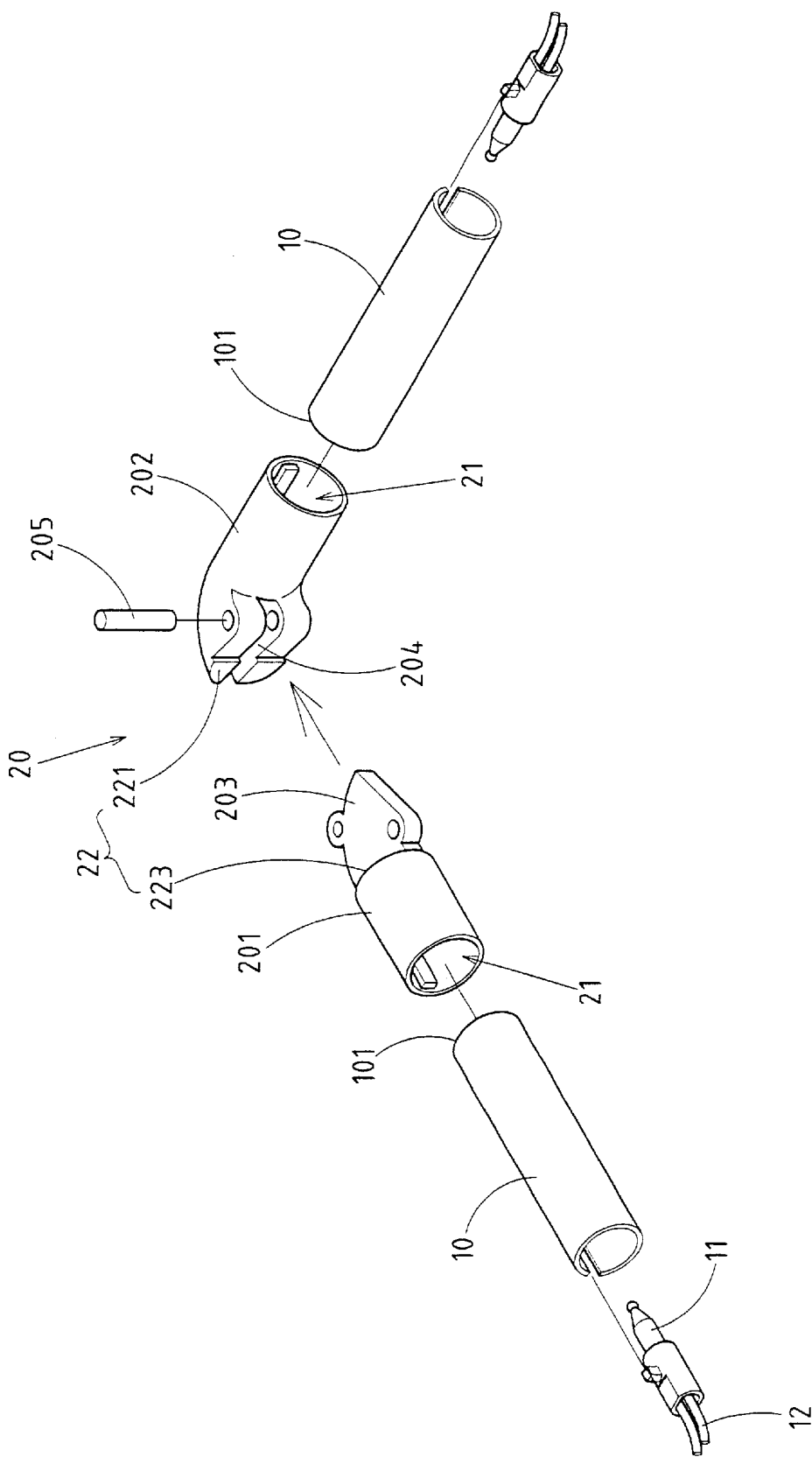

FIG. 4

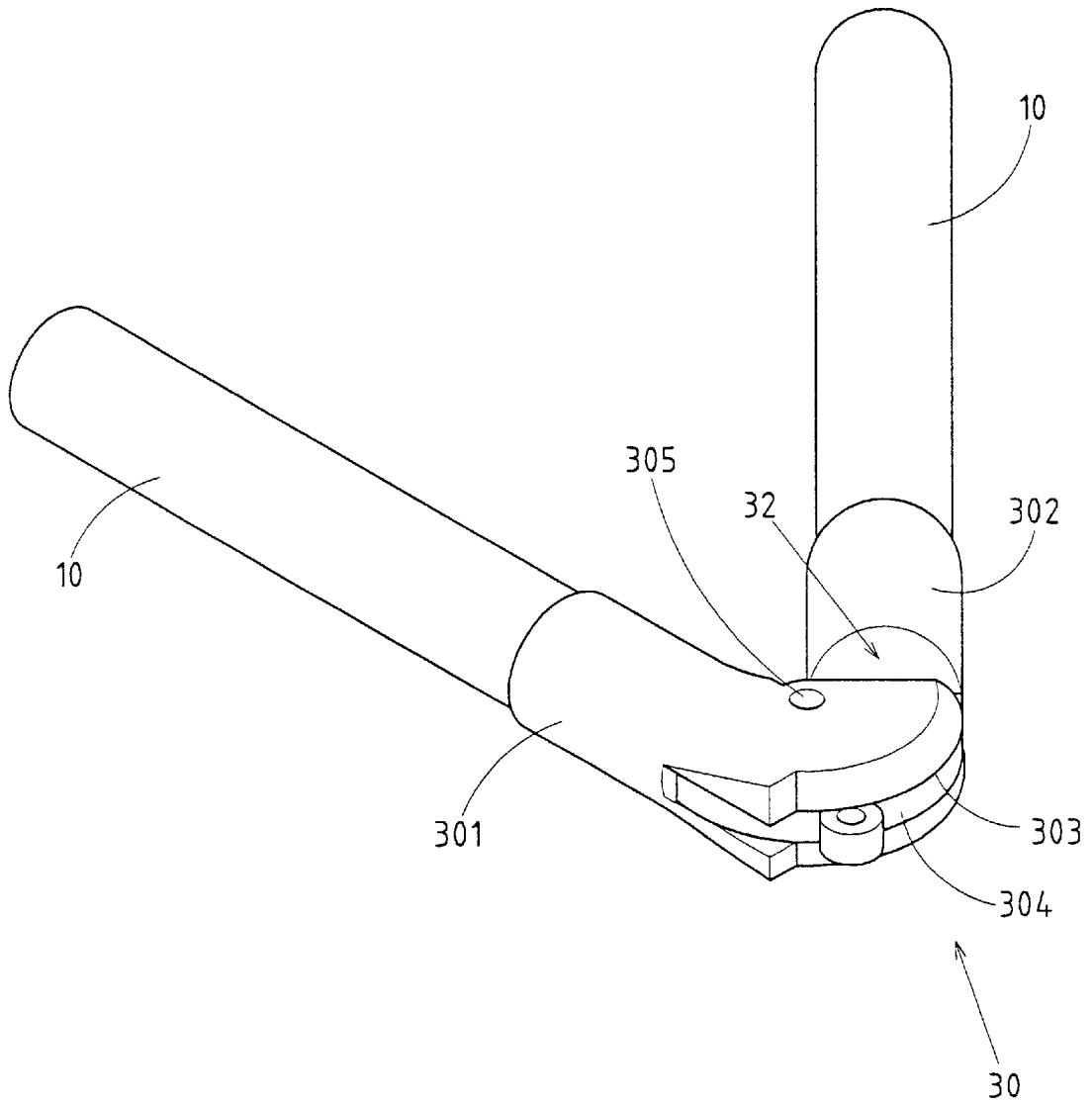

FIG. 5

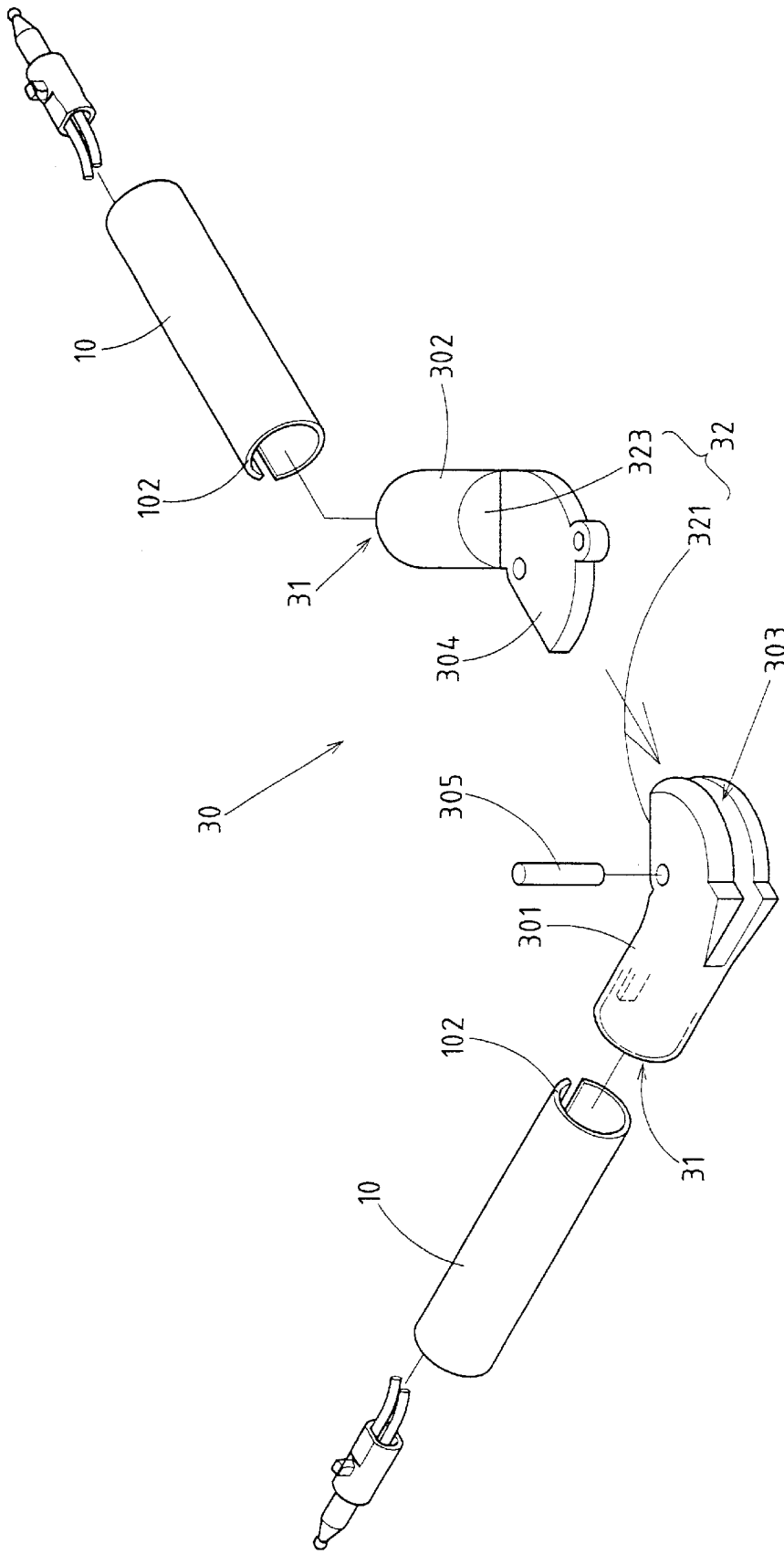

FIG.6

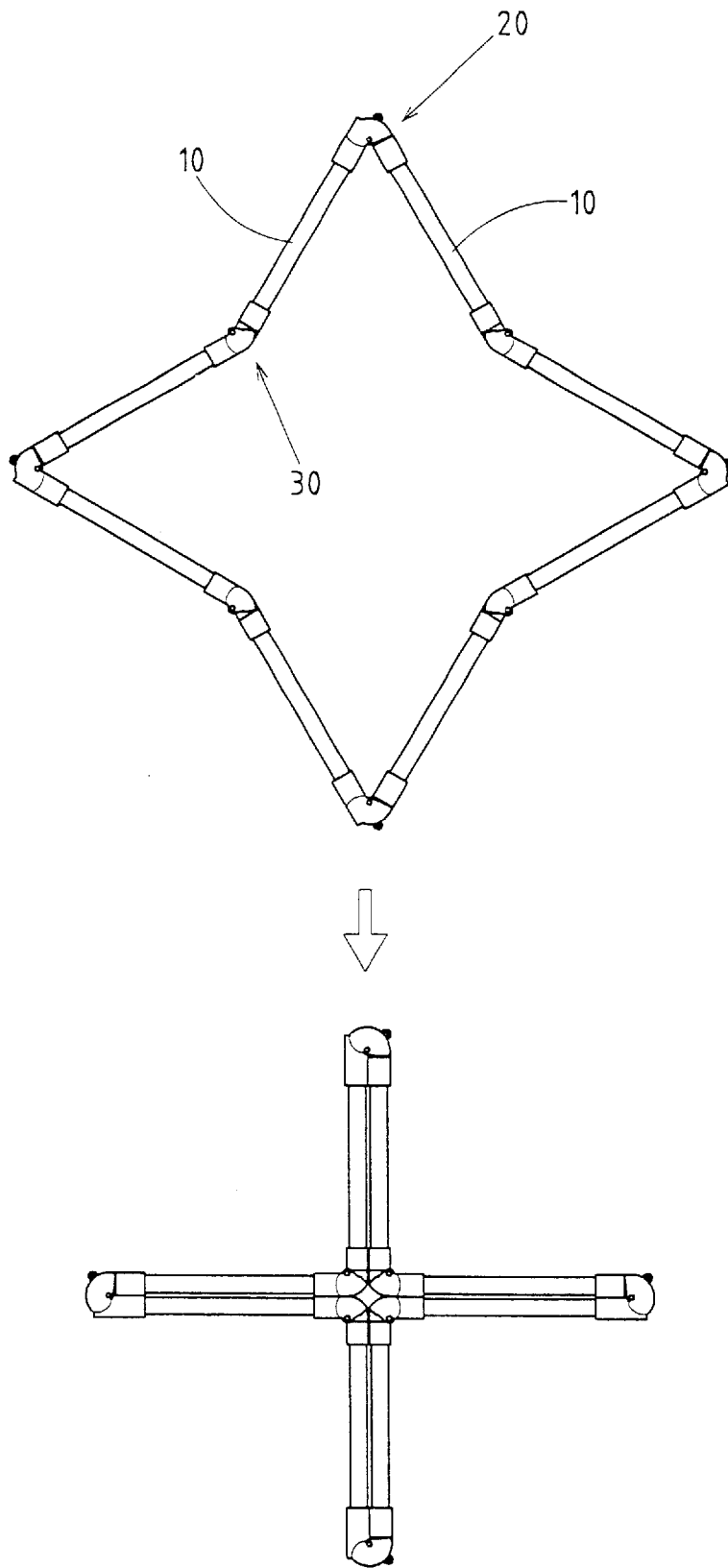

FIG. 7

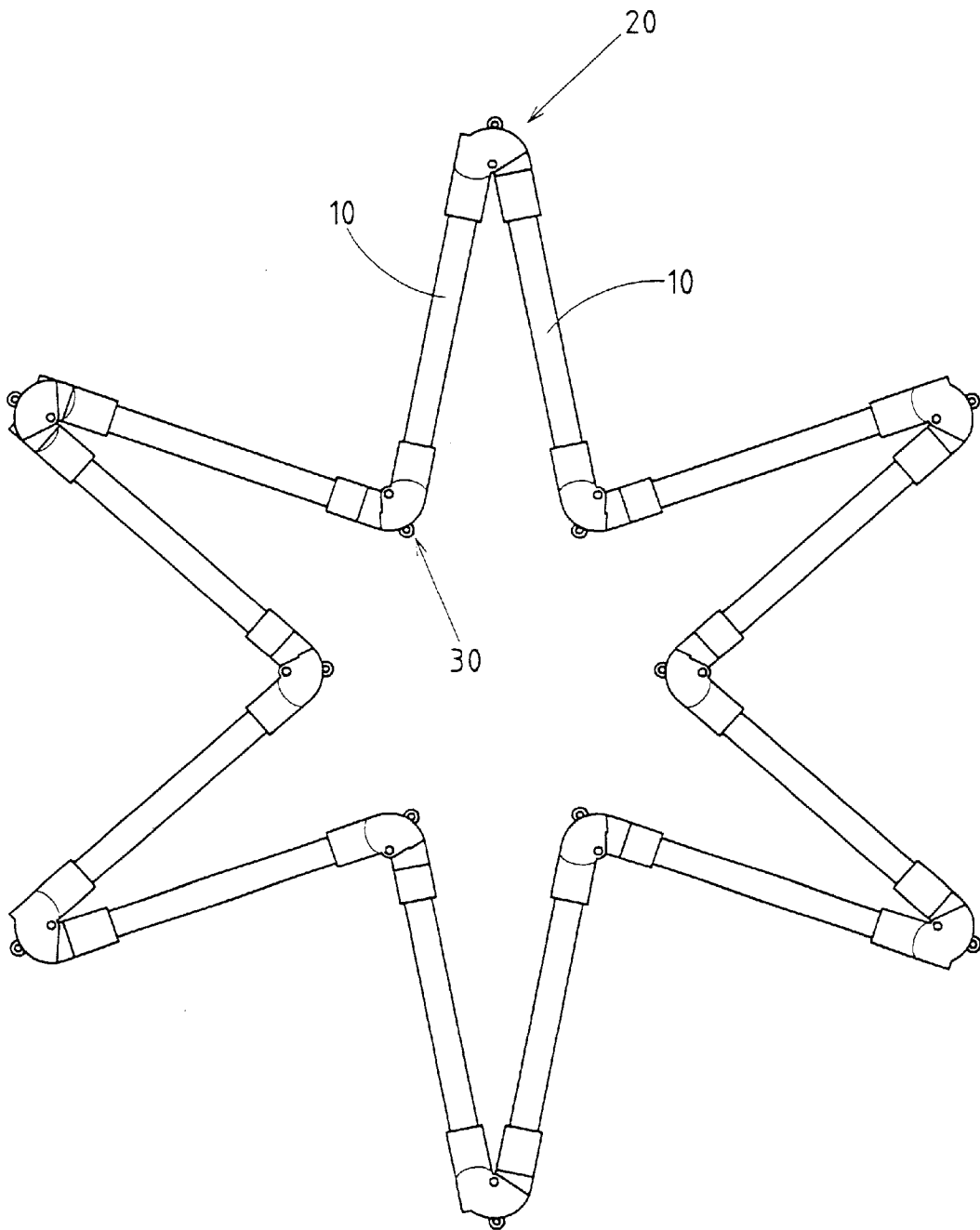

FIG. 8

1

LIGHTING STRUCTURE USED FOR DECORATING

RELATED U.S. APPLICATIONS

Not applicable.

STATEMENT REGARDING FEDERALLY SPONSORED RESEARCH OR DEVELOPMENT

Not applicable.

REFERENCE TO MICROFICHE APPENDIX

Not applicable.

FIELD OF THE INVENTION

The present invention relates generally to a decorative lighting structure, and more particularly to a decorative lighting structure adjustable in form.

BACKGROUND OF THE INVENTION

The conventional decorative lighting structure is generally formed of a series of light bulbs, which are arranged by an electric cord. Such conventional lighting structure is suitable for use in decorating a tree, shrub, or the like; nevertheless it is not appropriate for use in decorating a wall. In addition, the light bulbs of the conventional lighting structure are susceptible to damage, especially at such time when the light structure is being retrieved. Moreover, the conventional lighting structure is so easily intertwined that it cannot be stored in an orderly manner.

BRIEF SUMMARY OF THE INVENTION

It is the primary objective of the present invention to provide a decorative lighting structure which is simple in construction and is versatile in design.

It is another objective of the present invention to provide a decorative lighting structure which is durable and collapsible for easy storage and transportation.

In keeping with the principle of the present invention, the foregoing objectives of the present invention are attained by a lighting structure comprising a plurality of lighting tubes which are joined together end to end by a plurality of movable joints, thereby enabling the lighting tubes to be arranged in various forms.

The features, functions, and advantages of the present invention will be more readily understood upon a thoughtful deliberation of the following detailed description of the present invention with reference to the accompanying drawings.

BRIEF DESCRIPTION OF THE SEVERAL VIEWS OF THE DRAWINGS

FIG. 1 shows a schematic plan view of the present invention in an unfolded state.

FIG. 2 shows a schematic plan view of the present invention in a folded state.

FIG. 3 shows a perspective view of a convex joint of the present invention.

FIG. 4 shows an exploded perspective view of the convex joint as shown in FIG. 3.

FIG. 5 shows a perspective view of a concave joint of the present invention.

2

FIG. 6 shows an exploded perspective view of the concave joint as shown in FIG. 5.

FIG. 7 shows a schematic view of the folding of the present invention.

5 FIG. 8 shows another schematic plan view of the present invention in an unfolded state.

DETAILED DESCRIPTION OF THE INVENTION

10 As shown in FIGS. 1-6, a lighting structure of the present invention is used for decorating and comprises a plurality of lighting tubes **10**, convex joints **20**, and concave joints **30**.

The lighting tubes **10** are joined together end to end by the convex joints **20** and the concave joints **30** such that the lighting tubes **10** can be arranged in various forms, thereby enabling the lighting structure of the present invention to take a stellar, cruciform, or snowflake shape. Each of the lighting tubes **10** is provided in the interior with two or more light bulbs **11**, which are respectively connected with a bonding wire **12**.

20 The convex joints **20** are formed of a first tubular member **201** and a second tubular member **202**, as shown in FIGS. 3 and 4. Both first tubular member **201** and the second tubular member **202** are provided with a fastening end **21** for fastening a first fastening end **101** of the lighting tubes **10**. 25 The first tubular member **201** is provided with a first pivoting end **203** opposite to the fastening end **21** of the first tubular member **201**. Similarly, the second tubular member **202** is provided with a second pivoting end **204** opposite to the fastening end **21** of the second tubular member **202**. The first pivoting end **203** of the first tubular member **201** is pivoted with the second pivoting end **204** of the second tubular member **202** by a pivot **205**.

30 The convex joints **20** are further provided with a confining member **22**, which is formed of a locating face **223** disposed in the first pivoting end **203** of the first tubular member **201**, and a locating edge **221** disposed in the second pivoting end **204** of the second tubular member **202**. The confining member **22** serves to confine the swiveling of the tubular members **201** and **202**.

40 The concave joints **30** are formed of a first tubular member **301** and a second tubular member **302**, which are respectively provided with a fastening end **31** for fastening a second fastening end **102** of the lighting tubes **10**, as shown in FIG. 6. The first tubular member **301** is provided with a first pivoting end **303** opposite to the fastening end **31** of the first tubular member **301**, whereas the second tubular member **302** is provided with a second pivoting end **304** opposite to the fastening end **31** of the second tubular member **302**. 45 The first pivoting end **303** and the second pivoting end **304** are pivoted together by a pivot **305**.

50 The concave joints **30** are further provided with a confining member **32**, which is formed of a locating edge **321** disposed in the first pivoting end **303** of the first tubular member **301**, and a locating face **323** disposed in the second pivoting end **304** of the second tubular member **302**. The confining member **32** serves to confine the swiveling of the two tubular member **301** and **302**.

60 By virtue of the swiveling actions of the convex joints **20** and the concave joints **30**, the lighting tubes **10** can be folded to take a snowflake form, as shown in FIG. 2, or a cruciform shape, as shown in FIG. 7.

65 In light of the confining effects of the confining member **22** of the convex joints **20** and the confining member **32** of the concave joints **30**, the lighting tubes **10** can be spread out to an extent that they take a stellar form, as shown in FIGS. 1, 7, and 8.

The shape formed by the lighting tubes **10** is dependent on the number of the lighting tubes **10** as well as the confining structures of the confining member **22** of the convex joints **20** and the confining member **32** of the concave joints **30**.

The present invention described above is to be regarded in all respects as being illustrative and nonrestrictive. Accordingly, the present invention may be embodied in other specific forms without deviating from the spirit thereof. The present invention is therefore to be limited only by the scope of the following claims.

I claim:

1. A decorative lighting structure comprising:

a plurality of lighting tubes, each tube comprising a first fastening end and a second fastening end, said lighting tubes being provided in an interior with one or more light bulbs;

a plurality of convex joints, each convex joint comprising a first tubular member and a second tubular member, said first tubular member being comprised of a fastening end and a first pivoting end, said second tubular member being comprised of a fastening end and a second pivoting end whereby each of said convex joints is used to fasten pivotally two of said lighting tubes in such a manner that said fastening end of said first tubular member is fastened to said first fastening end of one of the two lighting tubes, and that said fastening end of said second tubular member is fastened to said first fastening end of another one of the two lighting tubes, and that said first pivoting end of said first tubular member and said second pivoting end of said second tubular member are pivoted together by a pivot; and

a plurality of concave joints, each concave joint comprising a first tubular member and a second tubular member, said first tubular member being comprised of a fastening end and a first pivoting end, said second tubular member being comprised of a fastening end and a second pivoting end whereby each of said concave joints is used to fasten pivotally the two lighting tubes such that said fastening end of said first tubular member is fastened to said second fastening end of the one of the two lighting tubes, and that said fastening end of said second tubular member is fastened to said second fastening end of the other one of the two lighting tubes, and that said first pivoting end of said first tubular member and said second pivoting end of said second tubular member are pivoted together by a pivot.

2. The decorative lighting structure as defined in claim **1**, wherein said first pivoting end of said first tubular member and said second pivoting end of said second tubular member of said convex joints are comprised of a confining structure for confining swiveling of said first tubular member and said second tubular member of said convex joints; wherein said first pivoting end of said first tubular member and said second pivoting end of said second tubular member of said concave joints are comprised of a confining structure for confining swiveling of said first tubular member and said second tubular member of said concave joints.

* * * * *