



(11) **EP 1 933 419 A1**

(12) **EUROPEAN PATENT APPLICATION**

(43) Date of publication:
18.06.2008 Bulletin 2008/25

(51) Int Cl.:
H01Q 9/04 (2006.01)

(21) Application number: **06077257.1**

(22) Date of filing: **15.12.2006**

(84) Designated Contracting States:
AT BE BG CH CY CZ DE DK EE ES FI FR GB GR HU IE IS IT LI LT LU LV MC NL PL PT RO SE SI SK TR
Designated Extension States:
AL BA HR MK RS

- **Jofre Roca, Lluís,**
Universitat Polit. de Catalunya
08034 Barcelona (ES)
- **Serrano Calvo, Raquel**
Univers. Polit. de Catalunya
08034 Barcelona (ES)
- **Blanch Borios, Sebastian**
Univ. Polit. de Catal.
08034 Barcelona (ES)

(71) Applicant: **Seiko Epson Corporation**
Shinjuku-ku
Tokyo 163-0811 (JP)

(74) Representative: **Carvajal y Urquijo, Isabel et al**
Clarke, Modet & Co.,
C/ Goya No. 11
28001 Madrid (ES)

(72) Inventors:
• **Cairo Molins, J. I.,**
Epson Europe Electronics GmbH
2a Planta
08190 Sant Cugat Del Vallés
BA (ES)

(54) **Multiple feeding method for IC compatible multi-layer planar antennas and IC compatible multi-layer planar antenna with multiple feeding points**

(57) A feeding method for an IC compatible multi-layer planar antenna (10), said antenna comprising a ground plane (11) and L_i substantially parallel plates (12), $i=1, 2, \dots, N$ with $N \geq 2$, the method comprising:

- at least providing first current injection means (20, 21) in a first plate L_1 , for injecting current to a first layer and providing second current injection means (20', 21') in a second plate L_2 , for injecting a current to a second layer, the method further comprising
- injecting a current to said first current injection means and simultaneously or sequentially injecting current to said second current injection means, whereby the antenna operates at a first operating frequency-band f_1 and/or at a second operating frequency-band f_2 .

The invention also relates to an IC compatible multi-layer planar antenna with multiple feeding points.

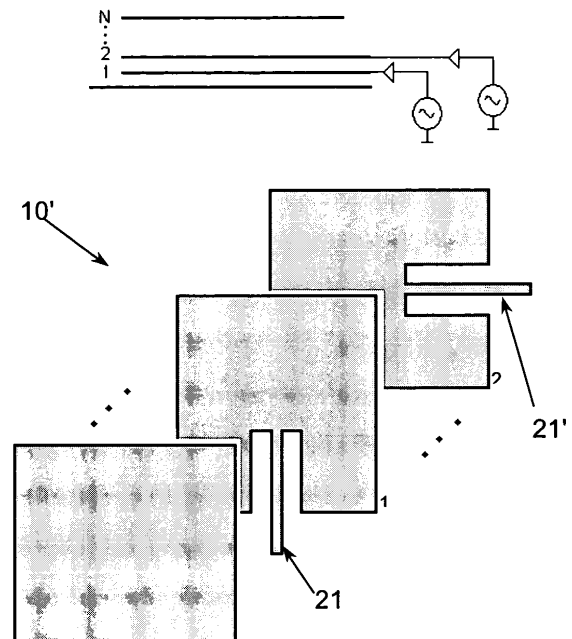

FIG. 3

EP 1 933 419 A1

Description

Field of the invention

[0001] The invention relates to high frequency electromagnetic circuits (transmission lines, filters, antennas), and more particularly to multi-layer planar antennas.

[0002] The general application fields of the invention are radio communications, particularly wireless/mobile digital communications, the mentioned multi-layer antennas being ultra-thin or IC compatible, that is, having a thickness of about 1 mm.

Background of the invention

[0003] Antennas for portable devices need to be small, power efficient and compatible with the portable structure. More recently a big interest exists in finding antenna designs compatible with IC integrated technologies. At the habitual wireless application operating frequencies (from some hundreds of MHz to some GHz) wavelength (λ) dimensions are in the order of tens of centimetres. When compact solutions are intended, designs tend to reduce as much as possible transversal (width, W) and thickness (height, H) dimensions. In order to obtain enough efficiency and minimum bandwidth, current designs use widths (W) above one fifth of the wavelength ($\lambda/5$) and thickness above one fiftieth of the wavelength ($\lambda/50$). At the mentioned wireless frequencies that implies transversal dimensions in the order of several centimetres and thickness in the order of several millimetres. On the other hand, IC integrated technologies are able to deal with transversal dimensions (W) below the centimetre, and thickness below the millimetre. In consequence current solutions tend to combine the antenna and the associated electronics into a back to back architecture, which normally prevents the antenna to be fully integrated into the IC package. For example, at the current 1.8/1.9 GHz bands, transversal dimensions of 2 cm and thickness of 4 mm for single layer antennas are needed. When multilayer solutions are used for frequency bandwidth increase or multifrequency operation, several times the current thickness are additionally needed, which is totally incompatible with the IC dimensions.

[0004] The solution proposed in the present invention provides a new IC compatible technique to connect printed circuit based multilayer antennas to multi-feed systems in such a way that small, efficient integrated antenna systems may be designed for applications as multi-antenna systems (MAE) or Multiple Input Multiple Output systems (MIMO).

[0005] As a general rule, printed circuits are formed by two parallel plates: a lower plate, usually working as the ground plane, and an upper plate, in which the different radiofrequency passive elements (filters, transmission lines, printed antennas, etc.) and active electronic devices are configured.

[0006] In conventional patch antennas, the feeding

point is applied in the top plane of the antenna. The injected current generates a field distribution inside the antenna, which in the case of an efficient and well matched antenna radiates to the surrounding air. The radiated energy is maximum at the operating frequency-band of the antenna which depends on the antenna dimensions and the position of the feeding point.

[0007] A thin stacked shorted patch antenna for the 1800 MHz frequency band is presented in "Thin dual-resonant stacked shorted patch antenna for mobile communications" Ollikainen J et al., Electronic Letters, 18 March 1999, Vol. 35, No. 6. Said antenna is dual-resonant and small in size, having a very low profile and a bandwidth of almost 10%. It thus discloses a stacked configuration for a patch antenna, each of the patches (lower and upper) working at a different resonant frequency.

Summary of the invention

[0008] The present invention is related to a new technique of feeding energy into an IC compatible multi-layer planar antenna and to the IC compatible multi-layer planar antenna resulting thereof.

[0009] The invention refers to a multiple feeding method for an IC compatible multi-layer planar antenna according to claim 1 and to an IC compatible multi-layer planar antenna according to claim 6. Preferred embodiments of the method and antenna are defined in the dependent claims.

[0010] In a multi-layer antenna there are a number N of layers, $N \geq 2$. In such a multi-layer antenna it is possible to apply the feeding point to different planes of the patch ($i=1,2..N$). In each case there is a change in the resonant frequency of the antenna.

[0011] The present invention is related to the multi-layer transformation technique applied in planar antennas such as patch antennas, where the antenna is formed by superposing different parallel planes one on top another. They are used as impedance transformers, so the feeding point can be impedance adapted to the free air impedance. Using the multi-layer configuration applied in previous antennas as impedance transformation technique, one or more feeding points can be applied in one or different layers to obtain multi-resonant characteristics.

[0012] That is, by changing the layer feeding position, it is possible to change the resonant frequency of the antenna. In this way, it is possible to have a multi-resonant antenna, by means of selecting the feeding connection plane.

[0013] A first aspect of the invention relates to a feeding method for an IC compatible multi-layer planar antenna, said antenna comprising a ground plane and Li substantially parallel plates, $i=1, 2, \dots N$, being $N \geq 2$, the method comprising:

- providing at least first current injection means in a

first plate L_1 , for injecting a current in a first layer and providing second current injection means in a second plate L_2 , for injecting a current in a second layer, the method further comprising

- injecting a current in said first current injection means and simultaneously or sequentially injecting a current in said second current injection means, whereby the antenna operates at a first operating frequency-band f_1 and/or at a second operating frequency-band f_2 .

[0014] Said first operating frequency-band f_1 and said second operating frequency-band f_2 may have different values.

[0015] With respect to the stated background, this invention permits a specific multi-layer planar antenna to operate in different frequency-bands; so that said antenna can be applied to different frequency working bands: a multi-band antenna is obtained. That is, the same antenna can be used to fit the requirements of multi-standard applications.

[0016] Preferably, further injection means are provided in the first plate and current is simultaneously injected both to said first current injection means and to said further current injection means.

[0017] If current is simultaneously injected both to said first current injection means and to the second current injection means, the first injection means can be arranged perpendicularly to the second current injection means. Also, if current is simultaneously injected both to said first current injection means and to the further current injection means in the same first layer, the first injection means can be arranged perpendicularly to the further current injection means. Thus, the present invention also permits achieving a polarisation control of the radiated power from the antenna.

[0018] The method may further comprise providing i -th current injection means in a i -th plate L_i , for injecting a current to a i -th layer.

[0019] Said first and second current injection means may comprise a microstrip feed, a coaxial cable, a coplanar line or any other transmission line geometry.

[0020] A second aspect of the present invention relates to an IC compatible multi-layer planar antenna, comprising a ground plane and L_i substantially parallel plates, $i=1, 2, \dots, N-1$, being $N \geq 2$, the antenna comprising:

- first current injection means in a first plate L_1 , for injecting a current to a first layer,

[0021] According to this second aspect of the invention, the antenna further comprises:

- at least second current injection means in a second plate L_2 , for injecting a current to a second layer,

the antenna resonating at a first resonant frequency f_1 as a response of a current injected to said first current

injection means, and resonating at a second resonant frequency f_2 as a response of a current injected to said first current injection means.

[0022] Said first resonant frequency f_1 and said second resonant frequency f_2 may have different value.

[0023] The antenna may include further injections means in the first plate for injecting further current to said first layer.

[0024] Current may be simultaneously injected in different layers both to said first current injection means and to second current injection means; or it may be simultaneously injected in a single layer to said first current injection means and said further injection means. In such cases, the first injection means can be arranged perpendicularly to the second current injection means or to the further injection means; this way, polarisation of the antenna is achieved.

[0025] Said first and second current injection means may comprise a microstrip feed, a coaxial cable, a coplanar line or any other transmission line geometry.

[0026] According to a preferred embodiment of the invention, the different layers in the multi-layer antenna have substantially the same overall dimensions.

[0027] The resulting architecture is suitable for monolithic integration. In fact, the overall planar dimensions of the multi-layer antenna are in the order of a tenth of the wavelength $\lambda/10$; and the thickness of the multi-layer planar antenna is in the order of a hundredth of the wavelength $\lambda/100$ or below. It is important to underline this latter fact: the solution proposed here provides an antenna geometry which is fully compatible with the multilayer IC technology, meaning that the antenna is designed using the multilayer IC frame itself in such a way that small, efficient integrated antennas may be designed. For doing so transversal and thickness dimensions are simultaneously reduced due to the particular matching effect between the highly unequal input port impedance and the antenna radiation impedance produced by the compacted multilayer structure where the thickness of the layers is in the order of tenths of millimetres (1/10's mm) very differently from the tens of millimetres (10's mm) used on the conventional multilayer antenna geometries. This is due to the fact that the tuning method of the present invention is preferably applicable to antennas as defined in EP application No. 05078048.5, and so are the antennas themselves.

Short description of the drawings

[0028] A series of drawings aiding to better understand the invention and which are expressly related to a preferred embodiment of said invention, representing a non-limiting example thereof, is very briefly described below.

[0029] Figures 1A and 1B show a diagrammatic representation of the feeding method of the present invention in a multi-layer antenna, where feeding is done by means of a coaxial cable.

[0030] Figures 2B and 2B show another possibility of

feeding a multi-layer antenna, where feeding is done by means of a microstrip feed.

[0031] Figure 3 shows a multi-layer antenna where polarisation is achieved by means of using the feeding method of the present invention.

Description of preferred embodiments of the invention

[0032] As shown in figures 1A and 1B, depending on which plate/layer 12 of the multi-layer antenna 10 is used as a feeding point or current injections means, it is possible to change the operating frequency-band of the antenna.

[0033] In figure 1A the feeding point 20 is connected to the first plate/layer above the ground plate 11; in this case the antenna has a first operating frequency-band f_1 . In figure 1B the feeding point 20' is connected to the second plate/layer above the ground plate 11; in this case the antenna has a second operating frequency-band f_2 . Similarly, if current is injected to another plate/layer - different from the first and second plates/layers- of the multi-layer antenna, the latter operates at a third frequency-band.

[0034] As indicated before, the position of the feeding point can be applied in different ways. In figures 1A and 1B it is done using a transmission line such as coaxial cable, which passes through the ground plate to the top plate of the patch and it connects to it.

[0035] Figures 2A and 2B and 3 show that other types of current injection means can be used, such as the planar feed transmission line (microstrip, striplines, coplanar, etc.). The similar concept is applied, since using this feeding connection it is also possible to connect to different planes of the multi-layer antenna.

[0036] More particularly in figure 2A the microstrip feed 21 is carried out in the first layer above the ground plate 11; in this case the antenna has a first operating frequency-band f_1 . And in figure 2B the microstrip feed 21' is carried out in the second layer above the ground plate 11, whereby the antenna operates at a second operating frequency-band f_2 .

[0037] Though not specifically shown in the drawings, current feeding in any of the plates/layers of the antenna can be carried out by means of differential feeding.

[0038] Figure 3 shows a multi-layer planar antenna 10' where current is simultaneously injected to a first plate/layer and to a second plate/layer by means of respective planar (differential CPW) feeds 21, 21'. As shown in figure 3, said planar feeds 21, 21' of the first and second plates/layers have been arranged perpendicularly, such that the current injected to the first plate/layer is perpendicular to the current injected to the second plate/layer, thereby achieving the polarisation of the antenna.

Claims

1. Feeding method for an IC compatible multi-layer pla-

nar antenna (10), said antenna comprising a ground plane (11) and L_i substantially parallel plates (12), $i=1, 2, \dots, N$ with $N \geq 2$, the method comprising:

5 - at least providing first current injection means (20, 21) in a first plate L_1 , for injecting current to said a layer and providing second current injection means (20', 21') in a second plate L_2 , for injecting current to a second layer, the method further comprising:

10 - injecting current to said first current injection means and simultaneously or sequentially injecting current to said second current injection means, whereby the antenna operates at a first operating frequency-band f_1 and/or at a second operating frequency-band f_2 .

2. Feeding method according to claim 1, wherein said first operating frequency-band f_1 and said second operating frequency-band f_2 have different value.

3. Feeding method according to any of claims 1-2, wherein further injection means are provided in the first plate and wherein current is simultaneously injected both to said first current injection means (20, 21) and to said further current injection means (20', 21').

4. Feeding method according to any of claims 1 or 3, wherein the current injected to the first injection means is injected perpendicularly to the current injected to the second current injection means or to the further injection means.

5. Feeding method according to any previous claim, wherein it further comprises providing i -th current injection means in a i -th plate L_i , for injecting a current to a i -th layer.

6. - An IC compatible multi-layer planar antenna (10), comprising a ground plane (11) and L_i substantially parallel plates, $i=1, 2, \dots, N$ (12), being $N \geq 2$, the antenna comprising:

45 - first current injection means (20, 21) in a first plate L_1 , for injecting current to a first layer, **characterised in that** the antenna further comprises:

50 - at least second current injection means (20', 21') in a second plate L_2 , for injecting a current to a second layer,

55 the antenna operating at a first operating frequency-band f_1 as a response of a current injected to said first current injection means, and operating at a second operating frequency-band f_2 as a response of a current injected to said second current injection means.

7. Antenna according to claim 6, wherein said first operating frequency-band f_1 and said second operating frequency-band f_2 have different value.
8. Antenna according to any of claims 6-7, wherein it comprises further injection means in the first plate for injecting further current to said first layer. 5
9. Antenna according to any of claims 6 or 8 when it depends on claim 6, wherein the first injection means is arranged perpendicularly to the second current injection means or to the further injection means. 10
10. Antenna according to any of claims 6-9, wherein it further comprises i -th current injection means in a i -th plate L_i , for injecting a current to a i -th layer. 15

20

25

30

35

40

45

50

55

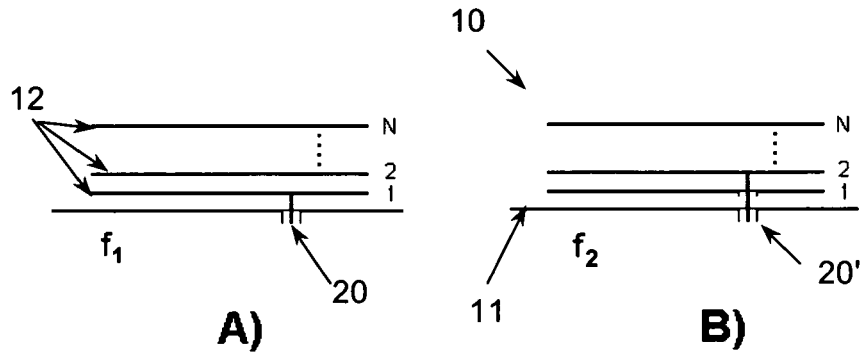

FIG. 1

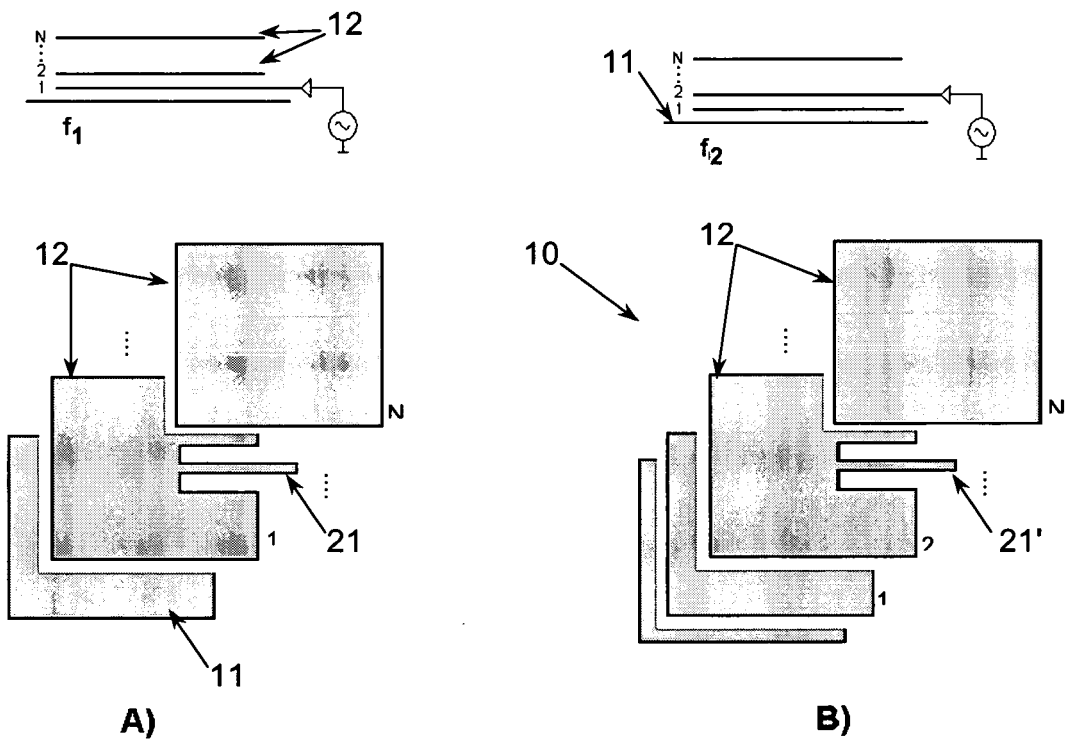

FIG. 2

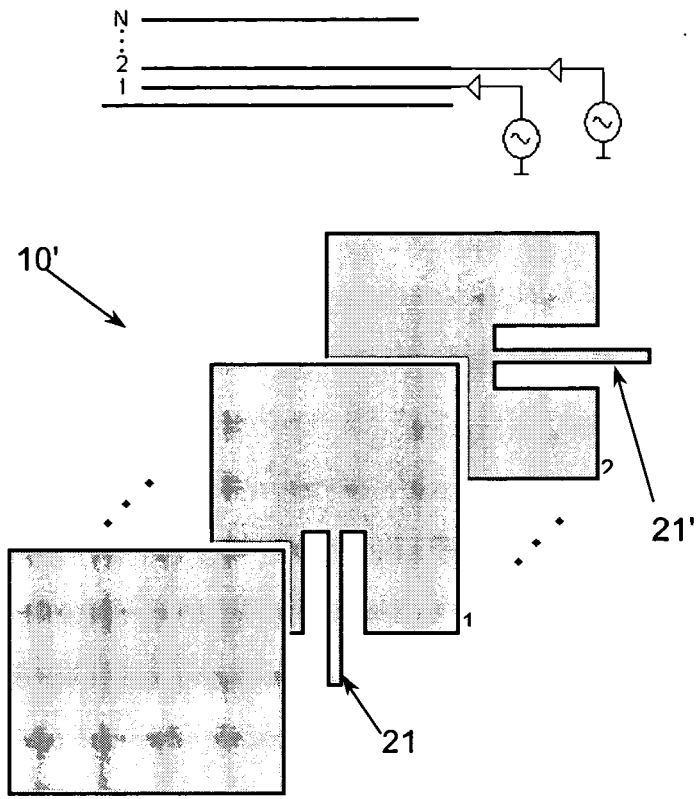

FIG. 3



DOCUMENTS CONSIDERED TO BE RELEVANT			
Category	Citation of document with indication, where appropriate, of relevant passages	Relevant to claim	CLASSIFICATION OF THE APPLICATION (IPC)
X	US 5 270 722 A (DELESTRE XAVIER [FR]) 14 December 1993 (1993-12-14) * column 2, line 8 - column 4, line 14; figures 2-8 *	1,3,4,6, 8,9	INV. H01Q9/04
X	US 4 070 676 A (SANFORD GARY G) 24 January 1978 (1978-01-24) * column 2, line 37 - column 3, line 2; figure 1 * * column 4, line 50 - line 61; figure 5 *	1-3,5-8, 10	
A	WO 99/34477 A (HSIN HSIEN CHUNG [US]) 8 July 1999 (1999-07-08) * page 13, line 9 - page 14, line 16; figures 7a,7b *	3,8	
A	US 3 921 177 A (MUNSON ROBERT E) 18 November 1975 (1975-11-18) * column 4, line 22 - column 6, line 43; figures 1-3 *	3,8	
A	WO 2006/071139 A (ERICSSON TELEFON AB L M [SE]; MANHOLM LARS [SE]; HARRYSSON FREDRIK [SE]) 6 July 2006 (2006-07-06) * abstract; figure 1 *	1-10	
The present search report has been drawn up for all claims			TECHNICAL FIELDS SEARCHED (IPC) H01Q
Place of search Munich		Date of completion of the search 22 June 2007	Examiner LA CASTA MUNOA, S
<p>CATEGORY OF CITED DOCUMENTS</p> <p>X : particularly relevant if taken alone Y : particularly relevant if combined with another document of the same category A : technological background O : non-written disclosure P : intermediate document</p> <p>T : theory or principle underlying the invention E : earlier patent document, but published on, or after the filing date D : document cited in the application L : document cited for other reasons & : member of the same patent family, corresponding document</p>			

4
EPO FORM 1503 03.82 (P04C01)

ANNEX TO THE EUROPEAN SEARCH REPORT
ON EUROPEAN PATENT APPLICATION NO.

EP 06 07 7257

This annex lists the patent family members relating to the patent documents cited in the above-mentioned European search report.
The members are as contained in the European Patent Office EDP file on
The European Patent Office is in no way liable for these particulars which are merely given for the purpose of information.

22-06-2007

Patent document cited in search report		Publication date	Patent family member(s)	Publication date
US 5270722	A	14-12-1993	DE 69116671 D1	07-03-1996
			DE 69116671 T2	27-06-1996
			EP 0493190 A1	01-07-1992
			FR 2671234 A1	03-07-1992

US 4070676	A	24-01-1978	CA 1067996 A1	11-12-1979
			DE 2633757 A1	14-04-1977
			FR 2327650 A1	06-05-1977
			GB 1526505 A	27-09-1978
			JP 1263539 C	16-05-1985
			JP 52046745 A	13-04-1977
			JP 59042484 B	15-10-1984

WO 9934477	A	08-07-1999	AU 7097398 A	19-07-1999
			EP 1064696 A1	03-01-2001

US 3921177	A	18-11-1975	CA 1031856 A1	23-05-1978
			DE 2418506 A1	24-10-1974
			FR 2226760 A1	15-11-1974
			GB 1470884 A	21-04-1977
			US RE29911 E	13-02-1979

WO 2006071139	A	06-07-2006	NONE	

REFERENCES CITED IN THE DESCRIPTION

This list of references cited by the applicant is for the reader's convenience only. It does not form part of the European patent document. Even though great care has been taken in compiling the references, errors or omissions cannot be excluded and the EPO disclaims all liability in this regard.

Patent documents cited in the description

- EP 05078048 A [0027]

Non-patent literature cited in the description

- **OLLIKAINEN J et al.** Thin dual-resonant stacked shorted patch antenna for mobile communications. *Electronic Letters*, 18 March 1999, vol. 35 (6 [0007]