

(19) World Intellectual Property Organization
International Bureau



(43) International Publication Date
23 January 2003 (23.01.2003)

PCT

(10) International Publication Number
WO 03/006138 A1

(51) International Patent Classification⁷: **B01D 35/30**,
35/31

20755 Georgia Avenue N., Forest Lake, MN 55025 (US).
WILSON, Craig, M.; 1023 17th Avenue S.E., Minneapolis,
MI 55414 (US).

(21) International Application Number: PCT/US02/22204

(74) Agents: **DOLGORUKOV, D., Edward** et al.; Marshall &
Melhorn, LLC, 8th Floor, Four SeaGate, Toledo, OH 43604
(US).

(22) International Filing Date: 12 July 2002 (12.07.2002)

(25) Filing Language: English

(81) Designated States (*national*): AE, AG, AL, AM, AT, AU,
AZ, BA, BB, BG, BR, BY, BZ, CA, CH, CN, CO, CR, CU,
CZ, DE, DK, DM, DZ, EC, EE, ES, FI, GB, GD, GE, GH,
GM, HR, HU, ID, IL, IN, IS, JP, KE, KG, KP, KR, KZ, LC,
LK, LR, LS, LT, LU, LV, MA, MD, MG, MK, MN, MW,
MX, MZ, NO, NZ, OM, PH, PL, PT, RO, RU, SD, SE, SG,
SI, SK, SL, TJ, TM, TN, TR, TT, TZ, UA, UG, UZ, VN,
YU, ZA, ZM, ZW.

(26) Publication Language: English

(30) Priority Data:
60/305,565 13 July 2001 (13.07.2001) US

(71) Applicant: **HEMERUS MEDICAL, LLC** [US/US];
1957 Gateway Boulevard, St. Paul, MN 55112 (US).

(84) Designated States (*regional*): ARIPO patent (GH, GM,
KE, LS, MW, MZ, SD, SL, SZ, TZ, UG, ZM, ZW),
Eurasian patent (AM, AZ, BY, KG, KZ, MD, RU, TJ, TM),

(72) Inventors: **ZIA, Majid**; 4695 Centerville Road, White
Bear Township, MN 55127 (US). **ANGELO, Anthony, J.**;

[Continued on next page]

(54) Title: SNAP TOGETHER FILTER

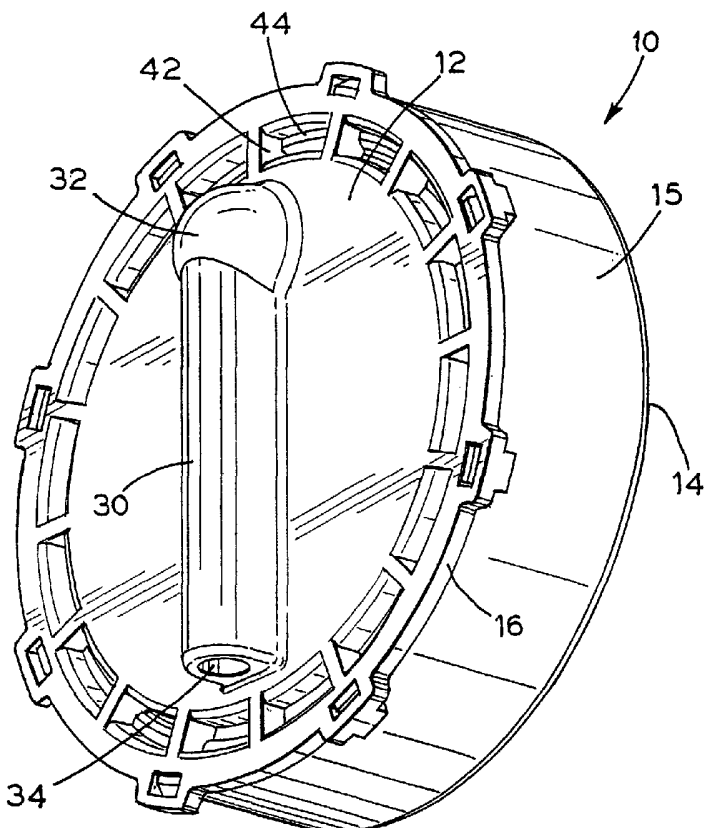

(57) Abstract: A fluid filter (10) is provided with a snap-together housing for the filter media. The housing (10) includes a first housing portion (12) and a second housing portion (14) that are easily snapped together to encapsulate the filter media.



WO 03/006138 A1



European patent (AT, BE, BG, CH, CY, CZ, DE, DK, EE, ES, FI, FR, GB, GR, IE, IT, LU, MC, NL, PT, SE, SK, TR), OAPI patent (BF, BJ, CF, CG, CI, CM, GA, GN, GQ, GW, ML, MR, NE, SN, TD, TG).

For two-letter codes and other abbreviations, refer to the "Guidance Notes on Codes and Abbreviations" appearing at the beginning of each regular issue of the PCT Gazette.

Published:

— *with international search report*

TITLE

SNAP TOGETHER FILTER

BACKGROUND OF THE INVENTION

5 1. Field of the Invention

The present invention relates to a filter device with a snap together housing. More particularly, the present invention is drawn to a housing for a biological fluid filter, preferably for the filtration of blood leukocytes.

10 Known filters for blood filtration systems utilize a variety of filter media depending on the application desired. Because of the biological nature of the material being filtered, it is required that the filter housing be hermetically sealed to prevent leakage from the filter, or contamination of material within the filter housing. Typically the filter housing is sealed by methods such as sonic welding, heat treatment or by adhesive compounds.

20 These known methods of sealing the filter housings all have significant disadvantages. In the case of heat treatment or sonic welding, some filter media may be susceptible to damage by the application of such high-energy methods of sealing to the filter housings. For example, glass based filtration media are not suitable for use when the housing is to be sonically welded, as the media may be damaged in the process. Adhesives can have the drawback of potential contamination of the filter media by components from the adhesive, which may be leached into the interior of the housing.

30 Additionally, with these methods it is difficult to insure that the entire periphery of the filter housing is hermetically sealed, e.g. gaps in the adhesive or failures of sections of the sonic weld. Additionally, these forms of sealing prevent the housing from being

35

easily disassembled in the future, as they are in essence "permanent" bonds.

The housing of the present invention is designed as a multi-piece unit, with two main sections. The main sections of the housing can be easily snapped together, around a filter media, to form the outer housing for the filter media. Various methods (such as an o-ring, or other sealing structure) can be applied to seal the filter housing.

SUMMARY OF THE INVENTION

The problems of the prior art are solved by the present invention utilizing a multi-part housing, preferably a two-part housing, with snap connectors to connect the parts together.

The housing can be made of any material that is commonly used for filter housings in the art. The connectors, to connect the housing sections together, can either be primarily outside the outer periphery of the housing, or primarily inside the outer periphery of the housing.

The housing is preferably cylindrical, with an inlet and an outlet disposed on the opposing major faces of the circular housing. In other applications, other geometries, for example square or hexagonal, can be used. In use, the cylindrical housing will typically be oriented with the longitudinal axis of the cylinder substantially parallel to the ground.

Each of the inlet and the outlet will preferably also have a tubular flow channel, on face of the cylinder on which it is disposed. Each tubular flow channel will have an opening to the outside of the housing, and an opening into the housing.

Inside the housing, on each of the opposing major internal faces of the housing, are preferably raised ridges, which raised ridges are positioned to abut the

filter media inside the housing. These ridges can support the filter media to hold it in its proper position, and/or the ridges can control the flow of fluid on either side of the media to insure that fluid flows through the entirety of the filter media and is not overly concentrated in one particular area of the filter.

In general, any filter media, as is customarily used in the art, is suitable for use with the present invention.

A primary reason for the development of the present invention has been to develop a biological fluid filter in which captured biological substances within the housing may be easily recovered and/or may be easily processed further to produce therapeutically valuable products. For example, in the case of leukocyte reduction from blood or blood products, it would be advantageous to recover the captured leukocytes for production of therapeutic products such as interferon. The filter media may also capture other cells or proteins that may be of therapeutic interest.

For example, in leukocyte reduction of whole blood, leukocytes and platelets are typically removed by the filter media and they are then disposed of. The present invention enables recovery of the main filter component (mainly the filter media) that contains therapeutic products of interest. The filter media may be processed separately to purify or separate out the therapeutic product of interest.

Thus, it is an object of the present invention to provide an improved housing for a fluid filter.

It is a further object of the invention to provide a housing for a filter device, which can be disassembled to recover material retained within the housing.

It is a further object of the invention to provide a housing for a filter device, which can be disassembled for the replacement of the filter media.

5 A further object of the invention is to provide a snap-together filter housing which can be easily assembled, but which is tamper resistant so that it cannot be easily disassembled without special tools or knowledge.

10 Yet another object of the invention is to provide a means of recovery of captured therapeutic components from a biological fluid.

Another object of the present invention is to provide a housing for a filter for filtering biological fluids.

15 Another object of the present invention is to provide a housing for a filter to separate out blood or blood products into their more valuable therapeutic products.

20 In one embodiment of the present invention the filter housing includes a filter media treated in a manner such that the media secured within the pinch seal provides a barrier to fluid flow across the pinch seal.

Although an o-ring is not necessary for such a design, o-ring(s) may be used. The snap together filter may not
25 be limited to a single use but at the same time is tamper resistant for certain critical applications such as in medical industry. The present invention provides a filter housing which is well suited for filtration of fluids such as blood or blood products in the medical
30 industry. More specifically the current invention is a well suited in a biological fluid filtration set such as those used for leukocyte reduction of blood and blood products. The captured cellular components may be easily removed from the filter housing after the set has
35 been used. The present invention is well suited for encapsulating one or multiple layers of filter media for

filtering biological fluids, especially blood or blood products. More specifically the present invention is well suited for leukocyte reduction of blood or blood products.

5 Further objects and advantages of the present invention will be apparent from the following description and appended claims, reference being made to the accompanying drawings forming a part of the specification, wherein like reference characters
10 designate corresponding parts in the several views.

BRIEF DESCRIPTION OF THE DRAWINGS

Fig. 1 is a perspective view of an embodiment of the present invention.

15 Fig. 2 is a front elevational view of the embodiment shown in Fig. 1.

Fig. 3 is a right side elevational view of the embodiment of the present invention shown in Fig. 1.

20 Fig. 4 is a left side elevational view of the embodiment of the present invention shown in Fig. 1.

Fig. 5 is a top view of the embodiment of the present invention shown in Fig. 1.

Fig. 6 is a bottom view of the embodiment of the present invention shown in Fig. 1.

25 Fig. 7 is a perspective view of an embodiment of the present invention.

Fig. 8 is a front elevational view of the embodiment shown in Fig. 7.

30 Fig. 9 is a right side elevational view of the embodiment of the present invention shown in Fig. 7.

Fig. 10 is a left side elevational view of the embodiment of the present invention shown in Fig. 7.

Fig. 11 is a top view of the embodiment of the present invention shown in Fig. 7.

35 Fig. 12 is a bottom view of the embodiment of the present invention shown in Fig. 7.

Fig. 13 is a sectional view through the line F-F of Fig. 1.

Fig. 14 is a sectional view through the line A-A of Fig. 7.

5 Fig. 15 is a side view of one of the housing sections of the embodiment shown in Figure 1.

Fig. 16 is a side view of the other housing section of the embodiment shown in Figure 1.

10 DESCRIPTION OF THE PREFERRED EMBODIMENT

Figures 1 through 6 represent a first embodiment of the present invention. In these figures, a filter 10 includes a first housing portion 12 and a second housing portion 14. The housing portions 12, 14 are constructed
15 separately so that a filter media (not shown) can be placed between them. The first housing portion 12, in this embodiment, has a ring 16 projecting radially outward from the peripheral wall 13 (see Fig. 13) of the housing. A plurality of projecting portions 18 is
20 disposed about the outer periphery of the ring 16. Each of the projecting portions 18 includes a notch 20. In other embodiments of the present invention, the notches can be cut directly in the ring 16 without the additional projections 18. The notches 20 can be made
25 substantially circular to a certain depth in the projecting portion, and can then be pressed in a substantially oval shape to make a notch through the entire thickness of the projection 18.

The other housing portion 14 includes a plurality
30 of tabs 22 which correspond to the notches 20. The tabs 22 project radially outwardly from the peripheral wall 15 (see Fig. 13) of housing section 14 at intervals that will align the tabs 22 to align with the notches 20 for assembly of the filter 10. In a preferred embodiment,
35 there are an equal number of tabs 22 and notches 20. When assembled, the outer wall 15 of housing portion 14

will be disposed about the outer wall 13 of housing portion 12. In preferred embodiments of the present invention, wall 13 can be of substantially the same length as wall 15, to arrange for a tight fit of the housing sections 12, 14 but can also be shorter than wall 15 in alternative embodiments.

The housing portion 12 additionally has an inlet tube 30 affixed to the outside of the housing. The tube 30 is preferably integrally constructed with the housing 12 but can be separately manufactured and attached. The tube includes an end 32, through which an opening (see Fig. 15) allows fluid to enter the housing section 12. The tube 30 also includes an inlet opening 34 for entry of fluid into the tube.

The housing portion 14 additionally has an outlet tube 36 corresponding to the inlet tube 30 on the opposing face. The outlet tube 36 again has an end 38 through which an opening (see Fig. 16) allows flow of fluid from the housing section 14 into the tube 36. An outlet 40 from the tube 36 thus allows the flow of filtered fluid from the filter 10. It is preferred that tubes 30 and 36 are disposed substantially parallel to each other, on the opposing faces of the filter, with their respective openings into the housings at opposite ends of the tubes, as depicted herein. In other embodiments of the present invention it may not be necessary for the tubes to be substantially parallel to each other and may instead be skew to one another.

In a preferred embodiment, the ends 32, 38 can be approximately the same size. In the embodiment shown in Figures 1-6, the end 32 is significantly larger than the end 38. Additionally, the end 38 is substantially cylindrical in nature, with the cylinder axis substantially perpendicular to the face of the housing section 14. The end 32, to the contrary, is substantially rounded, thus forming a substantially

hemispherical end. In at least one embodiment, the end 32 is larger than the end 38 because the end 32 is being used as the inlet for the material to be filtered. This end can be larger to prevent the blocking of the inlet due to particulate material in the fluid to be filtered. As the outlet side will have been filtered, this is not as much concern for the outlet. In other embodiments, the inlet and outlet can be the same size, or the outlet opening can even be larger than the inlet.

In addition, the exterior major faces of the housing sections 12, 14 can have a series of notches 42, 44 cut in the exterior face. The notches 44 are preferably in the form of a circular channel about the face of the second housing section 14, and are divided from one another by solid sections 50. The notches 42 are preferably separated from one another by solid sections 48. Additionally, the notches 42 preferably are not cut to a constant depth. Instead, the notches 42 preferably contain a stepped or raised portion 44 inside the notch 42. These notches are preferably aligned with raised portions in the interior of the housing sections (see Figures 15 and 16.)

In a preferred embodiment, the peripheral walls 13, 15 are angled slightly from perpendicular to the faces of the housing sections 12, 14. This can be done to allow the housing sections to easily fit over one another. The angle of these walls can be, for example, about three degrees from perpendicular. Other angles may also be possible, within the scope of the present invention, without adversely affecting the inventive housing. Additionally, the walls 13, 15 can be at substantially 90-degree angles to the faces of the housing sections 12, 14.

The design interconnection of the tabs 22 with the notch 20 can be seen in the sectional view shown in Figure 13. It can be seen here that the projection 18

from the wall 13 of the housing portion 12 also includes an additional projection 24, projecting substantially transverse to the projection 18. This projection 24 is substantially parallel to the peripheral wall 13 of the housing portion 12. A connecting portion 26 then projects from projection 24, substantially perpendicular to projection 24, back towards the peripheral wall 13 of housing portion 12.

Tab 22 can also be seen, on this figure, to include a connecting portion 28 projecting radially outward from the peripheral wall of housing portion 14. Thus, when assembled, the connecting portion 28 of tab 22 overlaps the connecting portion 26 from projection 24. This interconnection between the connecting parts 26, 28 can secure the two portions of the housing 12, 14 into a secure whole.

While the above discussed connection is illustrative of a manner to connect the two housing portions, it is not the only way the two housing portions can be snapped together. Other interlocking mechanisms can be suitable for use with embodiments of the present invention.

Figures 7-12 and 14 depict an alternative embodiment of the present invention. In this alternative embodiment, substantially similar components are identified by the same reference numeral. Components with a substantially different design or functionality are identified by a different reference numeral. A significant difference in these embodiments can be seen in Figure 14, which illustrates an alternative snap-together mechanism, which is utilized in this embodiment. In this snap-together mechanism, wall 15 of housing section 14 has notches 21 cut directly into the wall (which will be the exterior wall when assembled), and not on separate protruding sections. Wall 13 of housing section 12 has tabs 23

directly protruding substantially radially outward from the wall 13. As can be seen in Figure 14, the tab 23 is designed so that it has a slanted face, which will engage with the wall when it is being assembled, and then a face which is preferably substantially projecting radially transverse to the wall 15. Therefore, once the transverse face of the tab 23 slides into the notch 21, the tab 23 will "snap" into the notch 21 to form the "snap fit" as discussed above. If disassembly of the housing is required, for example to change the filter media, pressure against the tab 23 can remove it from the notch 21 and the housing can then be disassembled.

Other differences of the embodiment depicted herein, is that an end 33 of the inlet channel 30 is substantially identical in size and design to that of the end 38 of the outlet channel 36. Additionally, in Figure 10, there is no recessed ring on the face as there was in Figure 4. The recessed ring 47 in Figure 9 is of a uniform depth (except for the bridging material, which is of uniform depth with the face of the housing section 12).

In at least one embodiment of the present invention, the recessed ring in the outer face is designed, to as great an extent as possible, to make a uniform thickness in the outer housing. Thus, where there is a build up of material within the housing, the outer housing can be recessed to maintain as much uniformity as possible. This may improve the structural characteristics of the housing. Additionally, the design of the recessed areas can be decorative.

The above differences between the embodiments are not linked together in a given embodiment. Therefore the features of the differing embodiments can be exchanged between the embodiments depending on the final features desired in the product.

Any material commonly suitable as filter media, for the given application, can be used in the present invention. The housing can be made of any material suitable for use with the chosen fluid to be filtered. For example, for a blood leukocyte filter, any bio-compatible housing material can be used, for example polycarbonate, acrylic or their blends. While these materials are acceptable, they are not the only materials for such usage. A wide variety of materials for filter housings are known in the art and are suitable for use with the present invention. In addition, the housing or parts of the housing may be substantially transparent or substantially opaque. A transparent housing would allow visual inspection of the filter media within the housing without disassembly of the housing. An opaque housing would prevent the viewing of the filter media in applications where such viewing would be undesirable (for example, in a medical device where the filter was visible to the patient.) The material of the housing is not considered to be crucial to the design of the present invention.

While the present embodiments have depicted the first section of the housing 12 as being the inlet side, it is within the scope of the present invention that either the first section 12 or the second section 14 could serve as the inlet side.

Figure 15 shows the interior of the housing section 12 illustrated in Figure 1. In this embodiment, opening 50 allows the flow of fluid from the inlet tube. Inside the housing section 12 are a series of concentric ribs or pinch shields 52. In the embodiment shown, these ribs are designed as concentric arcs, extending along a significant portion of a hemisphere of the housing section 12. These ribs both support the filter media (not shown) and also regulate the flow of material through the housing section. The ribs can be designed

to maximize the utilization of the filter media to prevent over utilization of some areas of the filter media and under utilization of other areas of the filter media. An outer circular ring 54 defines the limits of the flow area of the fluid and further supports the filter media.

An additional optional feature of the invention is an O-ring 58. This O-ring can be positioned outside of the wall 13 in an optional groove (shown as dashed line 56). This O-ring can help to prevent leakage of fluid from the filter 10. In this embodiment, the O-ring will essentially be between the walls 13 and 15 when assembled. The O-ring is preferably positioned as near the projections 18 as possible without interfering with the snap-fitting action. In other embodiments, the O-ring can be disclosed anywhere between the walls.

Figure 16 illustrates a possible embodiment of the interior of housing section 14, as depicted in the embodiment shown in Figure 1. A flow opening 60 leads to the outlet tube allowing flow to exit the filter. Again, a series of concentric ribs 62, are disposed to support the filter media and to control fluid flow on the outlet side of the filter media. As in the case with housing section 12, a circular support 64 limits the flow of fluid on the outlet side of the filter media, and defines a recess 66 between the circular support 64 and the wall 15. An optional O-ring 68 can be placed in the recess between the circular support 64 and the wall 15. When the filter 10 is assembled the O-ring will then be between the top of wall 13 and the housing 14, thus providing a seal against leakage.

While the above described embodiments depict the optional use of one or two O-rings to prevent leakage in the filter, other placements of O-rings are acceptable.

Such O-rings are commonly known and used in the art and any such location, for example, outside both of the

filter sections adjacent the snap-together fittings, would be acceptable. The above discussed O-ring locations, while preferred, are not to be considered limiting. Additionally, the use of the O-rings at all is not required in the present invention.

As shown in Figures 15 and 16, the section 12 has fewer rings 52 than rings 62 in section 14. This is because it is believed that fewer rings, with wider flow passages, are preferable on the inlet side of the filter. The outlet side of the filter will essentially provide support against the differential pressure exerted on the filter media by the fluid. Therefore the additional rings 62 on the outlet side of the filter can result in improved support for the filter media and decreased hold-up and retention volumes of the filter. The rings on the inlet and outlet side provide support for the filter media which secures the filter media within a desired gap which reduces the possibility of fluid channeling within or around the filter media, improving the filter performance. Thus the rings operate as a "pinch shield" against "bypass" of the fluid. Other numbers and size of supports 52, 62 are possible within the scope of the present invention depending on the flow characteristics desired, and the fluid to be filtered.

While the above discussed embodiments reflect a cylindrical housing of the filter, other geometries may be appropriate. For example, a housing with a square or hexagonal cross-section may be appropriate for various applications. Other cross-sectional shapes for the filter housing, including both regular and irregular geometries, could be used in embodiments of the present invention.

The above discussed embodiments illustrate alternative snap-together fittings for the present invention. The snap together fittings allow the sections of the housing to be securely fastened, but

then to also be disengageable for later separation of the sections. This may be necessary for reasons such as removal and replacement of the filter media.

5 Additionally, the housing sections can be secured to each other by more permanent means, for example by sonic welding or adhesive. Such would be recommended in applications wherein separation of the filter parts was not desired subsequent to assembly.

10 Therefore, by carefully studying the problems present in prior art biological filtration fluid systems; we have developed a novel method and apparatus for a snap together filter.

15

20

25

30

35

CLAIMS

1. A snap-together filter housing comprising:
a first housing portion and a second housing
5 portion, each of said housing portions comprising a base
and a substantially cylindrical wall;

one of said housing portions comprising an inlet
and the other of said housing portions comprising an
outlet;

10 said substantially cylindrical wall of said first
housing portion having an inner diameter substantially
equal to the outer diameter of said substantially
cylindrical wall of said second housing portion, and
being configured to be disposed about said substantially
15 cylindrical wall of said second housing portion to form
a substantially leak-resistant seal between said first
and second housing portions; and

a plurality of snap together connectors configured
to secure said first housing portion and said second
20 housing portion to one another.

2. The filter housing according to claim 1,
wherein said plurality of snap together connectors
comprises a plurality of first connector portions
25 disposed on said wall of said first housing portion and
a plurality of second connector portions disposed on
said wall of said second housing portion.

3. The filter housing according to claim 2,
wherein:

said plurality of first connector portions
comprises a plurality of projecting portions;

5 said second housing portion comprises a ring
projecting radially outward from said wall of said
second housing portion, said ring being substantially
planar with said base of said second housing portion;
and

10 said plurality of second connector portions
comprises a plurality of receiving portions disposed in
said ring, each of said plurality of receiving portions
being configured to receive one of said plurality of
projecting portions.

15 4. The filter housing according to claim 3,
wherein:

each of said plurality of projecting portions
comprises a projection extending from the end of said
20 cylindrical wall of said first housing portion, each of
said projections comprising a tab projecting
substantially radially outward from said cylindrical
wall; and

25 each of said plurality of receiving portions
comprises:

30 a radial portion projecting substantially
radially outwardly from said ring, each of said
radial portions comprising a notch for receiving
one of said tabs of said plurality of projecting
portions; and

35 a transverse portion substantially parallel to
said wall of said second housing portion, said
transverse portion covering a portion of said notch
and being configured to form an interlocking
connection with a corresponding tab of said
plurality of receiving portions.

5. The filter housing according to claim 2,
wherein:

said plurality of first connector portions
comprises a plurality of notches disposed about the
periphery of said wall of said first housing portion;
5 and

said plurality of second connector portions
comprises a plurality of projections disposed about the
periphery of said wall of said second housing portion,
10 said projections being configured to engage with a
corresponding one of said plurality of notches.

6. The filter housing according to claim 5,
wherein each of said projections comprises a first side
15 substantially parallel to said base, a second side
adjacent said first side, said second side being
substantially perpendicular to said first side, and a
third side projecting from said second side at an angle
to said wall, to allow said first housing portion to
20 slide over said plurality of projections to engage said
plurality of projections with said plurality of notches.

7. The filter housing according to claim 1,
wherein each of said first and second housing portions
25 comprises plastic.

8. The filter housing according to claim 1,
wherein each of said first and second housing portions
is substantially opaque.
30

9. The filter housing according to claim 1,
wherein each of said first and second housing portions
are substantially transparent.
35

10. The filter housing according to claim 1, further comprising at least one O-ring to improve the leak resistance of said housing.

5 11. The filter housing according to claim 1, wherein each of said bases of said first and second housing portions has an inner face, facing toward the inside of the filter housing, and an outer face facing opposite said inner face, said filter housing further
10 comprising a plurality of flow directing ridges disposed on the inner face of each of said bases of said housing sections.

12. The filter housing according to claim 11,
15 wherein each of said flow directing ridges is in the shape of an arc.

13. The filter housing according to claim 12,
wherein said flow directing ridges are disposed
20 substantially symmetrically about a diameter of said filter housing.

14. The filter housing according to claim 1,
wherein said first housing portion comprises a support
25 ring, said support ring being disposed a first distance from the cylindrical wall of the first housing section.

15. The filter housing according to claim 14,
wherein said first distance is less than the thickness
30 of said wall of said second housing section.

16. The filter housing according to claim 14,
further comprising an O-ring disposed between said
support ring and said wall of said first housing
35 section.

17. The filter housing according to claim 14, wherein said second housing portion comprises a support ring.

5 18. The filter housing according to claim 17, wherein each of said housing portions comprises a series of notches forming a ring in the outer face, each of said series of notches projecting into said support ring of its housing portion.

10 19. The filter housing according to claim 12, wherein said first housing portion comprising about twice as many flow directing ridges as said second housing portion.

15 20. The filter housing according to claim 1, wherein said first housing portion comprises said inlet, and said second housing portion comprises said outlet.

20 21. The filter housing according to claim 20, wherein said inlet comprises an inlet tube disposed on the base of said first housing portion, said inlet tube having a first opening to the atmosphere and a second opening to the interior of the filter housing, and said
25 outlet comprises an outlet tube disposed on the base of said second housing portion, said outlet tube having a first opening to the atmosphere and a second opening to the interior of the filter housing.

30 22. The filter housing according to claim 21, wherein said opening to the interior of the filter housing of said inlet tube comprises one of: a bulbous chamber and a cylindrical chamber.

23. The filter housing according to claim 22, wherein said opening to the interior of the filter housing of said outlet tube comprises a substantially cylindrical chamber.

5

24. The filter housing according to claim 21, wherein said inlet tube and said outlet tube are designed to be substantially parallel to one another upon said first housing section being joined to said second housing section.

10

25. The filter housing according to claim 24, wherein said opening to the interior of the filter housing of said inlet tube and said opening to the interior of the filter housing of said outlet tube are designed to be disposed at opposite ends of said parallel tubes from one another.

15

26. The filter housing according to claim 1, wherein one of said cylindrical wall of said second housing section and said cylindrical wall of said first housing section contains a recess, said recess being disposed about the periphery of said cylindrical wall, said filter housing comprising an O-ring disposed in said recess about said cylindrical wall of said second housing portion.

20

25

27. The filter housing according to claim 1, wherein said plurality of snap together fittings are configured to be disengageable from each other after being secured, so that a filter disposed within said housing can be replaced.

30

35

28. The filter housing according to claim 1, wherein said plurality of snap together fittings are configured to be essentially permanently secured to each other, upon said filter housing being assembled.

5

29. The filter housing according to claim 1, wherein the housing is designed to be used in conjunction with a biological fluid filter.

10

30. A snap-together filter housing for a biological fluid filter comprising:

a first housing portion and a second housing portion, each of said housing portions comprising a base and a substantially cylindrical wall;

15

one of said housing portions comprising an inlet and the other of said housing portions comprising an outlet;

20

said substantially cylindrical wall of said first housing portion having an inner diameter substantially equal to the outer diameter of said substantially cylindrical wall of said second housing portion, and being configured to be disposed about said substantially cylindrical wall of said second housing portion to form a substantially leak-resistant seal between said first and second housing portions; and

25

a plurality of snap together connectors configured to secure said first housing portion and said second housing portion to one another; wherein

30

said plurality of snap together connectors comprises a plurality of first connector portions disposed on said wall of said first housing portion and a plurality of second connector portions disposed on said wall of said second housing portion;

said plurality of first connector portions comprises a plurality of projecting portions;

said second housing portion comprises a ring projecting radially outward from said wall of said second housing portion, said ring being substantially planar with said base of said second housing portion; and

said plurality of second connector portions comprises a plurality of receiving portions disposed in said ring, each of said plurality of receiving portions being configured to receive one of said plurality of projecting portions;

each of said plurality of projecting portions comprises a projection extending from the end of said cylindrical wall of said first housing portion, each of said projections comprising a tab projecting substantially radially outward from said cylindrical wall; and

each of said plurality of receiving portions comprises:

a radial portion projecting substantially radially outwardly from said ring, each of said radial portions comprising a notch for receiving one of said tabs of said plurality of projecting portions; and

a transverse portion substantially parallel to said wall of said second housing portion, said transverse portion covering a portion of said notch and being configured to form an interlocking connection with a corresponding tab of said plurality of receiving portions.

31. A snap-together filter housing for a biological fluid filter comprising:

a first housing portion and a second housing portion, each of said housing portions comprising a base and a substantially cylindrical wall;

one of said housing portions comprising an inlet and the other of said housing portions comprising an outlet;

said substantially cylindrical wall of said first housing portion having an inner diameter substantially equal to the outer diameter of said substantially cylindrical wall of said second housing portion, and being configured to be disposed about said substantially cylindrical wall of said second housing portion to form a substantially leak-resistant seal between said first and second housing portions; and

a plurality of snap together connectors configured to secure said first housing portion and said second housing portion to one another; wherein

said plurality of snap together connectors comprises a plurality of first connector portions disposed on said wall of said first housing portion and a plurality of second connector portions disposed on said wall of said second housing portion;

said plurality of first connector portions comprises a plurality of notches disposed about the periphery of said wall of said first housing portion; and

said plurality of second connector portions comprises a plurality of projections disposed about the periphery of said wall of said second housing portion, said projections being configured to engage with a corresponding one of said plurality of notches.

32. A snap-together filter housing for a biological fluid filter, comprising:

a first housing portion and a second housing portion, each of said housing portions comprising a base and a wall;

one of said housing portions comprising an inlet and the other of said housing portions comprising an outlet;

said wall of said first housing portion having an inner cross-sectional geometry substantially identical to the outer cross-sectional geometry of said wall of said second housing portion, and being configured to be disposed about said wall of said second housing portion to form a substantially leak-resistant seal between said first and second housing portions; and

a plurality of snap together connectors configured to secure said first housing portion and said second housing portion to one another.

33. The snap-together filter housing according to claim 32, wherein each of said walls has a regular cross-sectional geometry.

1/7

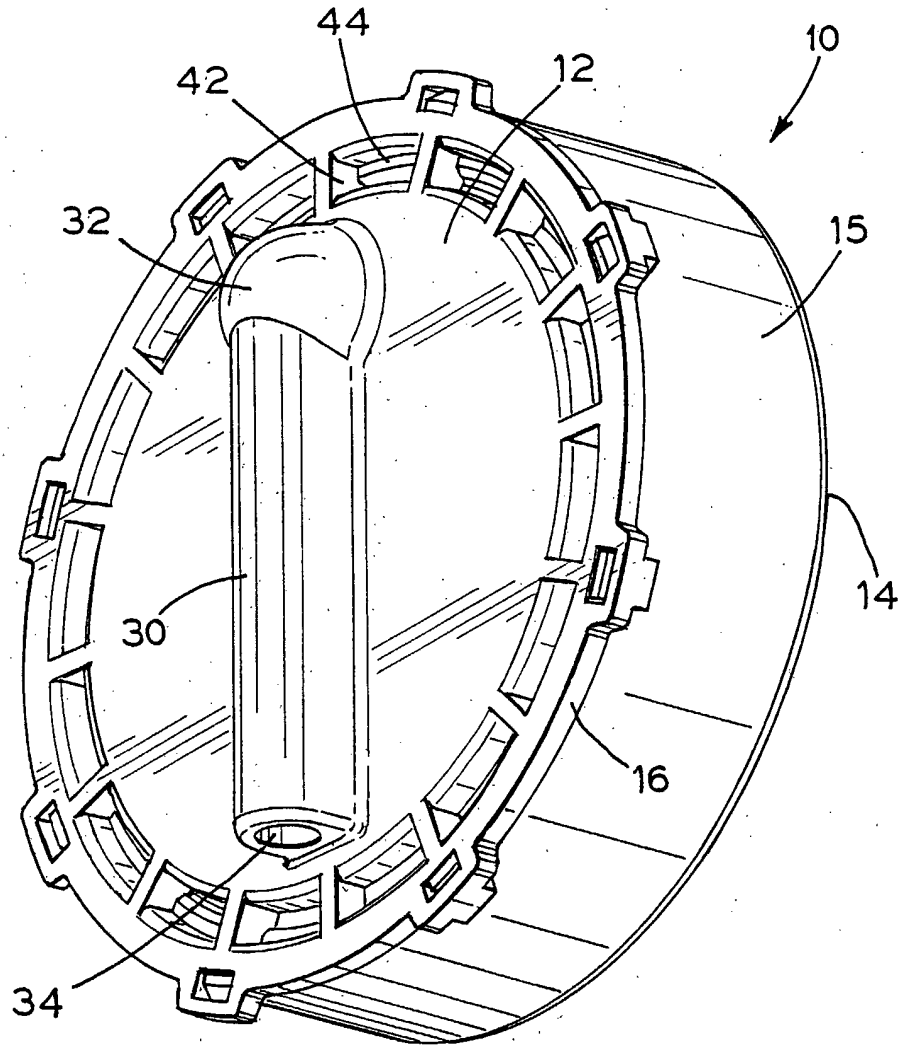

FIG. 1

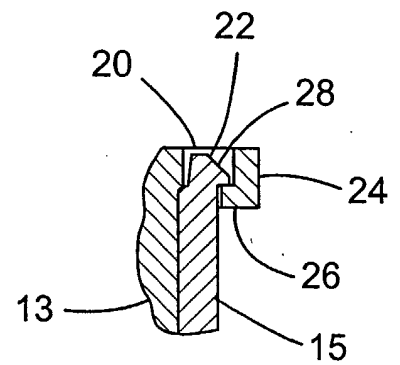
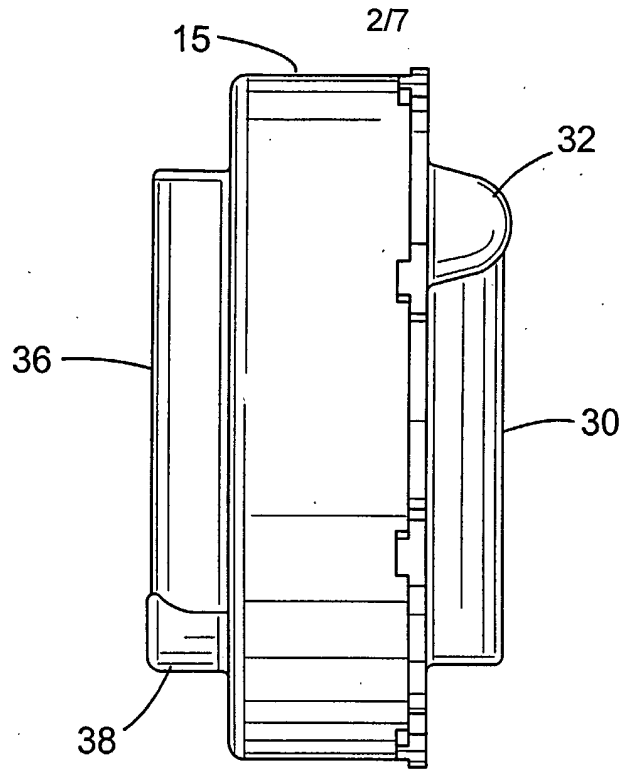

FIG. 2

FIG. 13

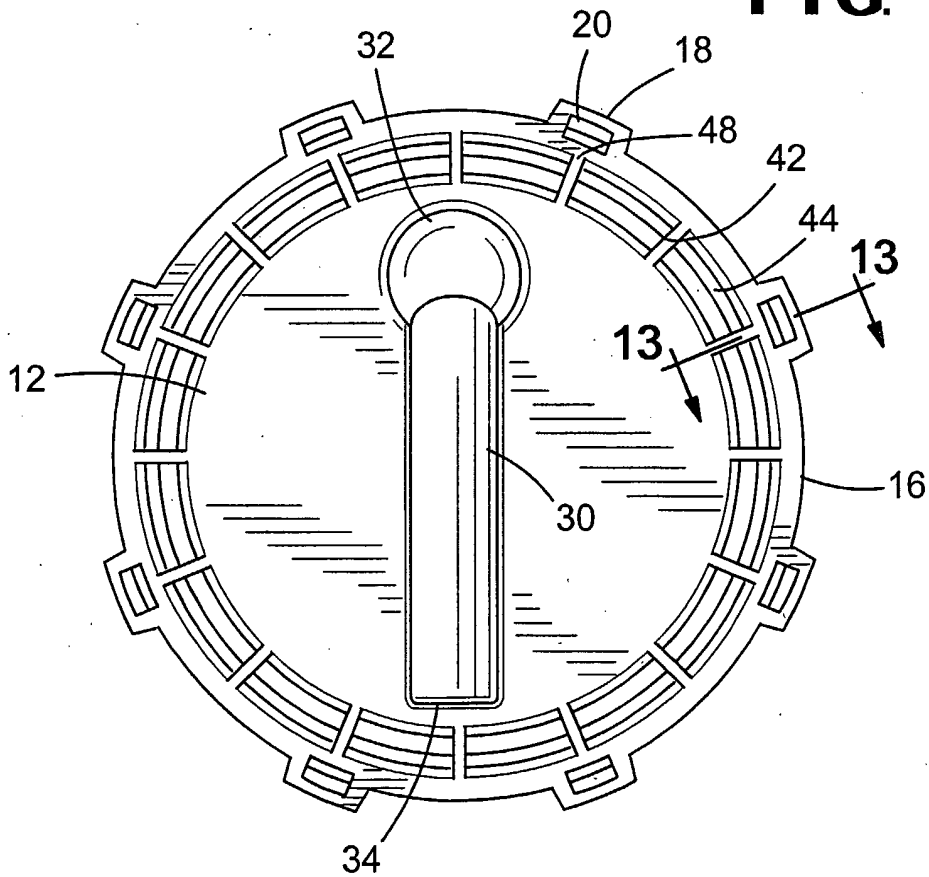

FIG. 3

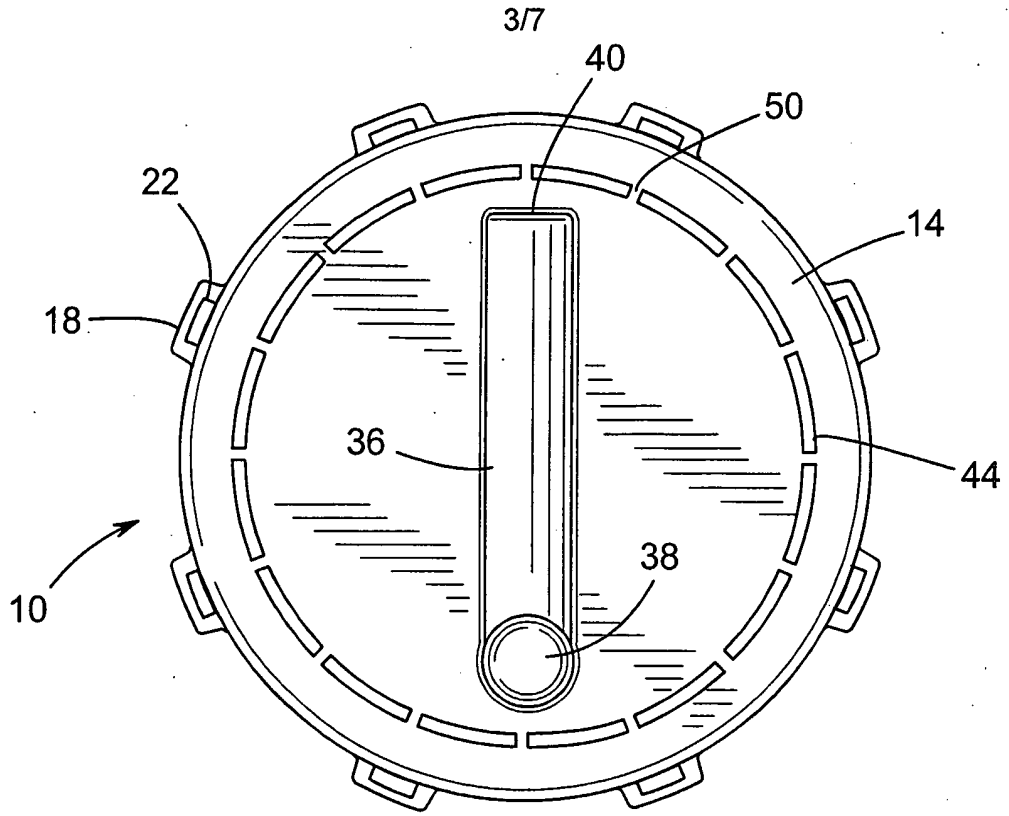

FIG. 4

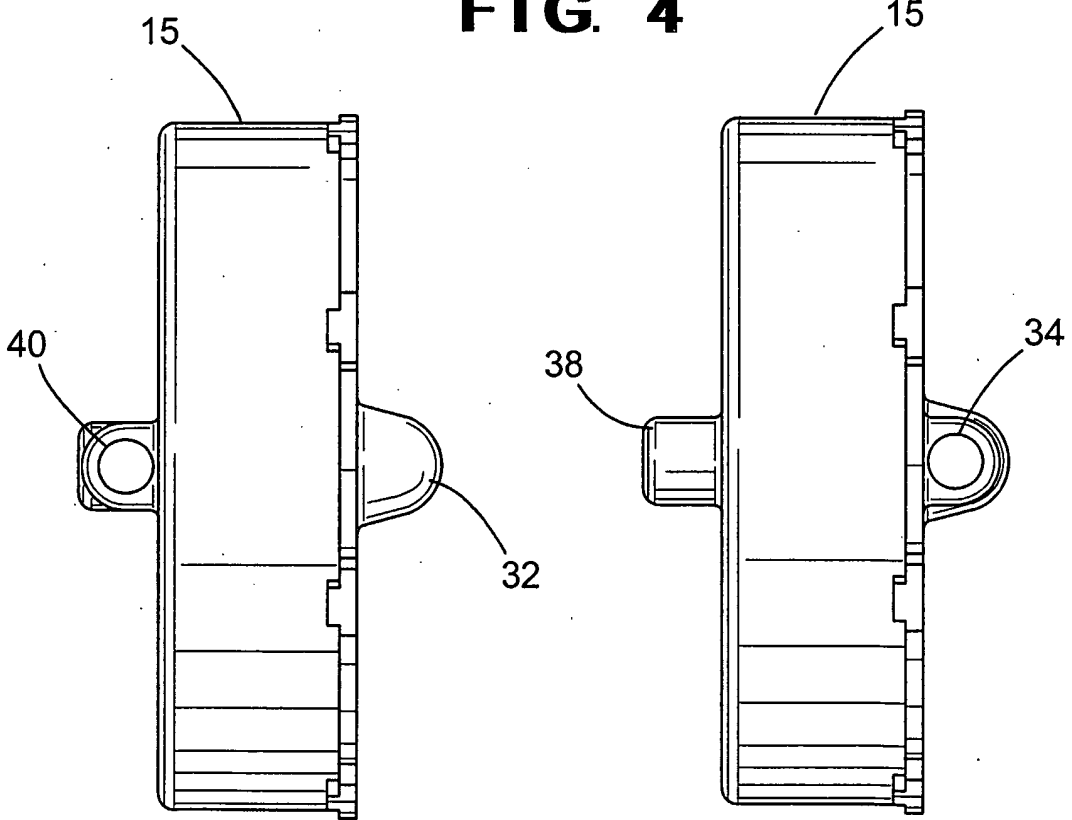

FIG. 5

FIG. 6

4/7

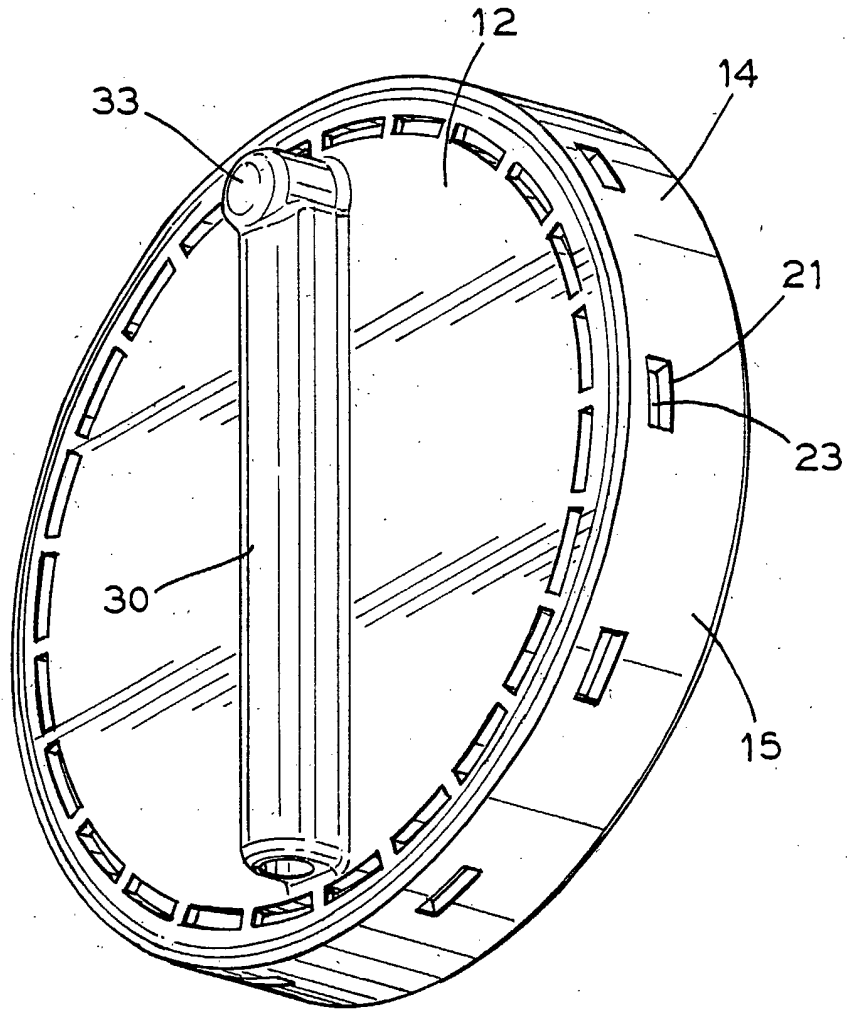

FIG. 7

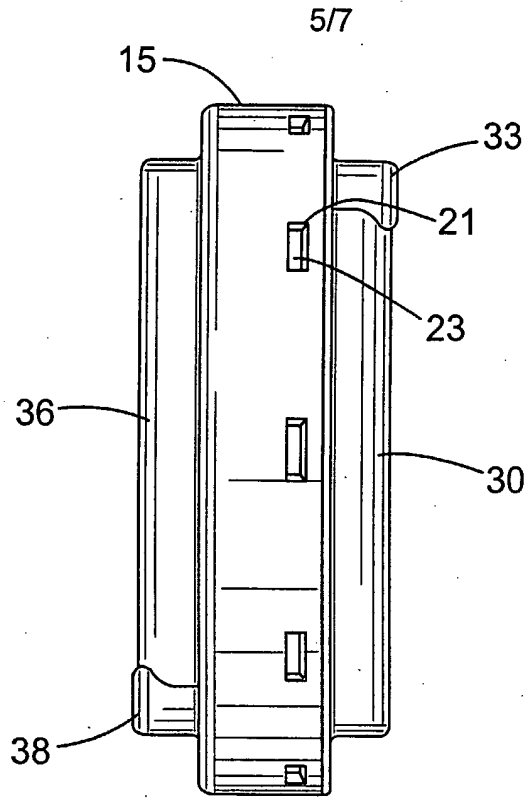

FIG. 8

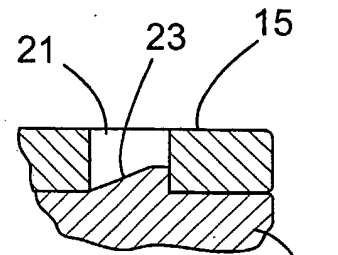

FIG. 14

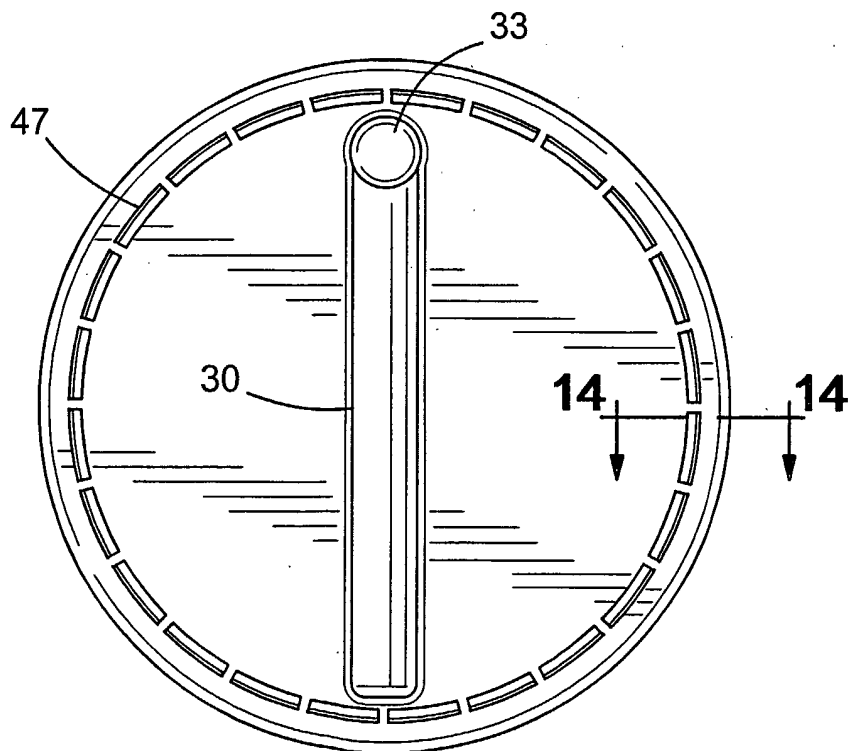

FIG. 9

6/7

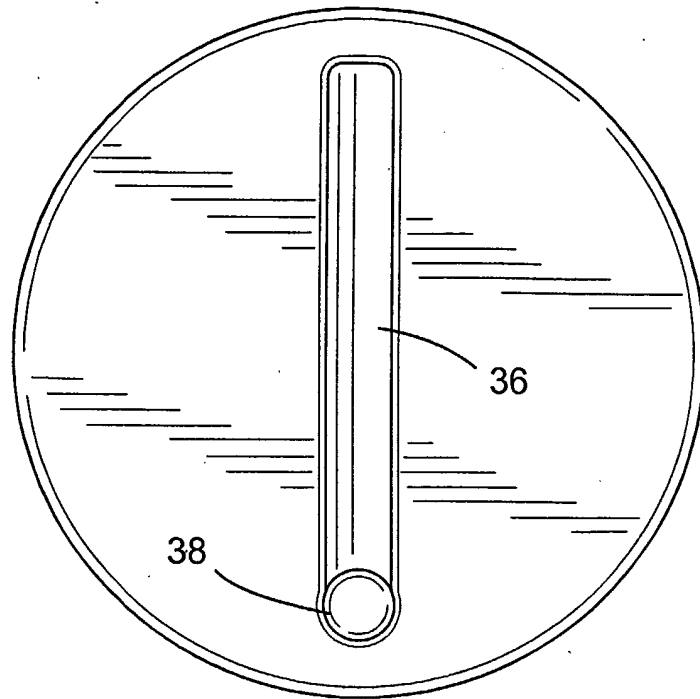

FIG. 10

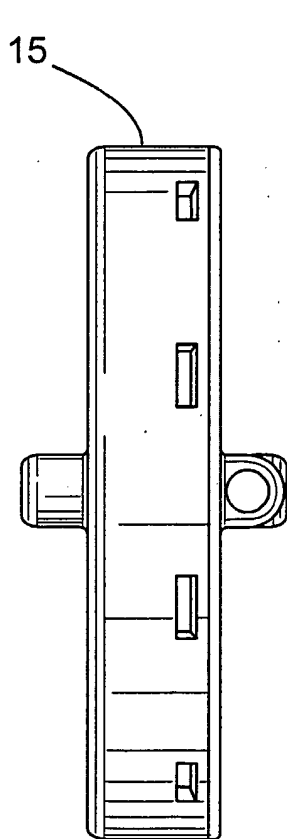

FIG. 11

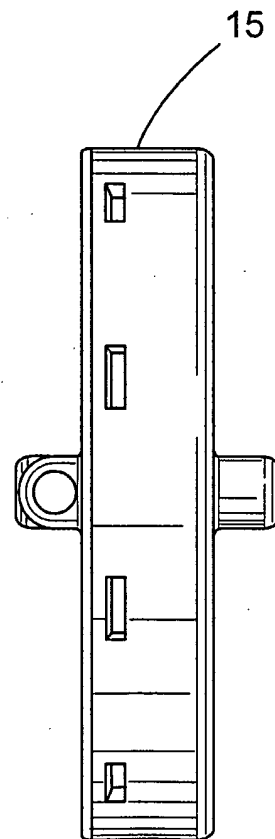

FIG. 12

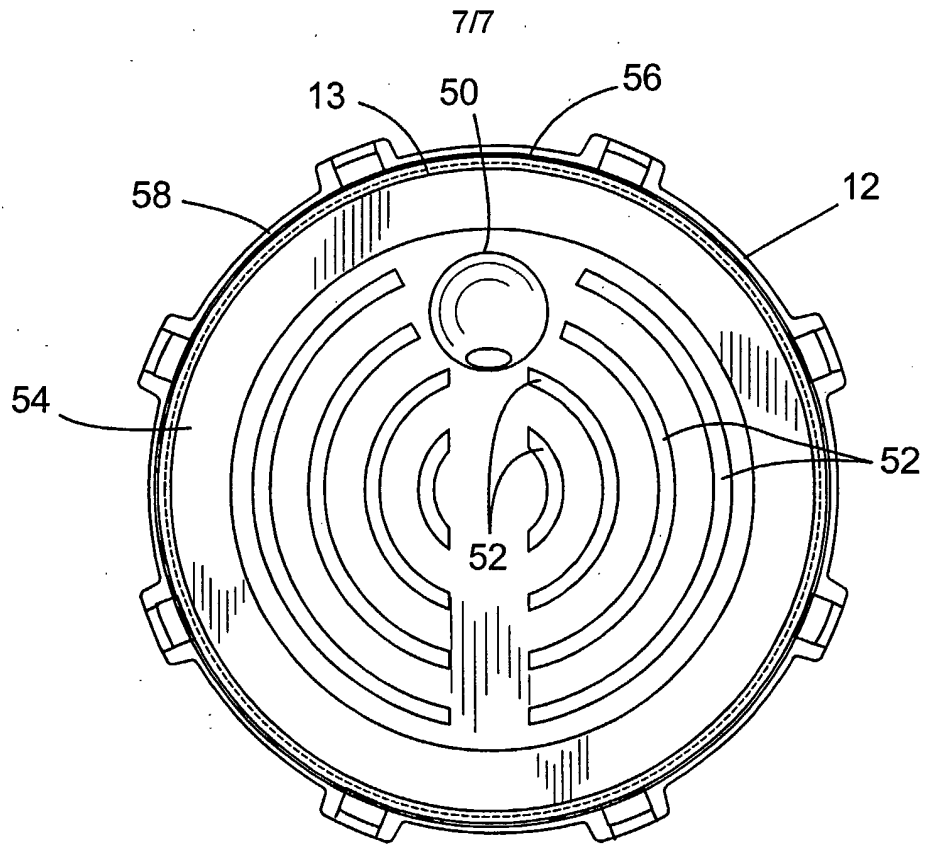

FIG. 15

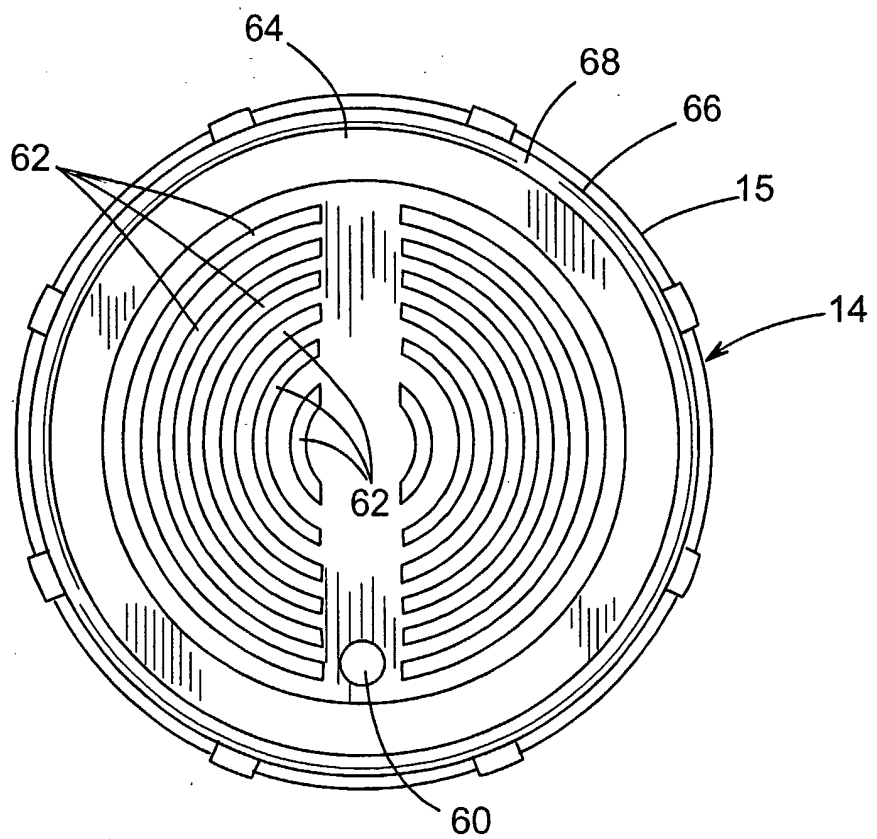

FIG. 16

INTERNATIONAL SEARCH REPORT

International application No.
PCT/US02/22204

A. CLASSIFICATION OF SUBJECT MATTER		
IPC(7) :B01D 35/30, 35/31 US CL :210/232, 445, 446, 450, 455 According to International Patent Classification (IPC) or to both national classification and IPC		
B. FIELDS SEARCHED		
Minimum documentation searched (classification system followed by classification symbols)		
U.S. : 210/232, 445, 446, 450, 455		
Documentation searched other than minimum documentation to the extent that such documents are included in the fields searched		
Electronic data base consulted during the international search (name of data base and, where practicable, search terms used)		
none		
C. DOCUMENTS CONSIDERED TO BE RELEVANT		
Category*	Citation of document, with indication, where appropriate, of the relevant passages	Relevant to claim No.
X	US 5,308,483 A (SKLAR et al) 03 May 1994, see entire document.	1-2, 5-10, 14-18, 20, 26-29 and 31-33
Y		----- 11-13, 19, 21-25
Y	US 5,443,723 A (STANKOWSKI et al) 22 August 1995, see entire document.	11-13, 19, and 21-25
<input type="checkbox"/> Further documents are listed in the continuation of Box C. <input type="checkbox"/> See patent family annex.		
* Special categories of cited documents:		
"A"	document defining the general state of the art which is not considered to be of particular relevance	"T" later document published after the international filing date or priority date and not in conflict with the application but cited to understand the principle or theory underlying the invention
"E"	earlier document published on or after the international filing date	"X" document of particular relevance; the claimed invention cannot be considered novel or cannot be considered to involve an inventive step when the document is taken alone
"L"	document which may throw doubts on priority claim(s) or which is cited to establish the publication date of another citation or other special reason (as specified)	"Y" document of particular relevance; the claimed invention cannot be considered to involve an inventive step when the document is combined with one or more other such documents, such combination being obvious to a person skilled in the art
"O"	document referring to an oral disclosure, use, exhibition or other means	"&" document member of the same patent family
"P"	document published prior to the international filing date but later than the priority date claimed	
Date of the actual completion of the international search		Date of mailing of the international search report
20 SEPTEMBER 2002		02 OCT 2002
Name and mailing address of the ISA/US Commissioner of Patents and Trademarks Box PCT Washington, D.C. 20231 Facsimile No. (703) 305-3230		Authorized officer THOMAS M. LITHGOW Telephone No. 703-308-0173 DEBORAH THOMAS PARALEGAL STENOGRAPHER <i>pat</i>