



(12) EUROPEAN PATENT APPLICATION

(43) Date of publication:
13.10.2004 Bulletin 2004/42

(51) Int Cl.7: B60T 8/00, B60T 8/26,
B60T 8/32

(21) Application number: 04008344.6

(22) Date of filing: 06.04.2004

(84) Designated Contracting States:
AT BE BG CH CY CZ DE DK EE ES FI FR GB GR
HU IE IT LI LU MC NL PL PT RO SE SI SK TR
Designated Extension States:
AL HR LT LV MK

(72) Inventors:
• Hamada, Chiaki
Toyota-shi Aichi-ken, 471-8571 (JP)
• Doura, Akifumi
Kariya-city Aichi-pref. 448-8650 (JP)

(30) Priority: 07.04.2003 JP 2003103136

(74) Representative:
Winter, Brandl, Fűrnis, Hübner, Röss, Kaiser,
Polte Partnerschaft
Patent- und Rechtsanwaltskanzlei
Alois-Steinecker-Strasse 22
85354 Freising (DE)

(71) Applicants:
• TOYOTA JIDOSHA KABUSHIKI KAISHA
Toyota-shi, Aichi 471-8571 (JP)
• Advics Co., Ltd.
Kariya-city, Aichi-pref. 448-8650 (JP)

(54) Vehicle braking control device for braking force distribution

(57) A braking control device for a vehicle executes braking force distribution (BFD) biased to front wheel, taking into account auxiliary braking control such as Braking assist control to be executed when an abrupt or full braking action is done by the driver. In BFD control, braking force on rear wheels is held at a holding braking force and braking force on the front wheels is incremented beyond braking force requested by a braking action of a driver. After the starting of BFD control, further increase in the braking action is reflected in the front wheel braking force. When the auxiliary braking control is executed, the holding braking force on the rear wheels and the increment of the braking force on the front wheels are determined based upon a demand of the auxiliary braking action as well as the braking action amount by the driver.

FIG. 6

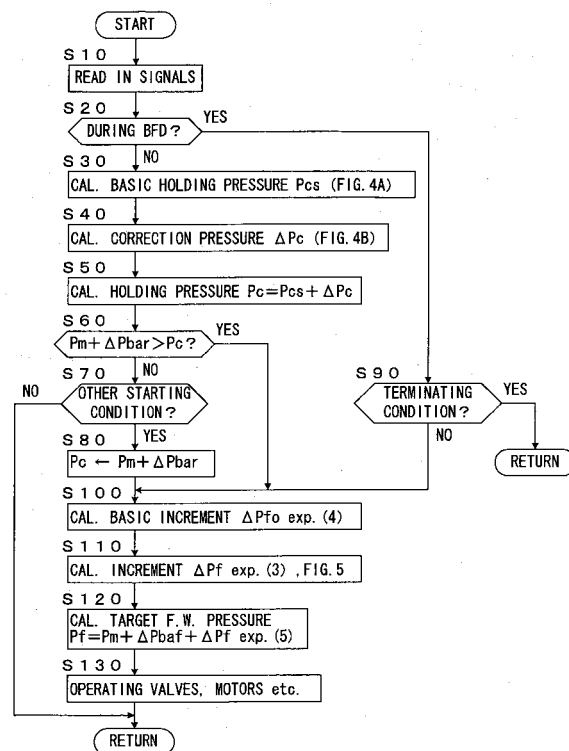

Description**Background of the Invention**5 *Field of the Invention*

[0001] The present invention relates to a device for controlling brakes of a vehicle such as an automobile, and more specifically, to such a device that controls braking force distribution among front and rear wheels in a vehicle.

10 *Description of Prior Art*

[0002] During braking of a vehicle, a rear wheel is liable to be locked because its frictional circle is shrunk due to the forward shifting of the load of the vehicle. The locking of a rear wheel, prior to a front wheel, induces serious deterioration of a vehicle running behavior, such as disturbance in the attitude and/or spinning of a vehicle body. In order to avoid the locking of a rear wheel, braking force distribution (BFD) control has been proposed to keep braking force on rear wheels lower than on the front wheels. In such BFD control, braking pressures applied to rear wheel cylinders in a hydraulic braking system is held, reduced or pulsatively increased, i.e. the increase in braking force generated on rear wheels is restricted, providing a distribution of braking force biased to front wheels. Usually, BFD control, often referred to as "Electronic Braking force Distribution Control (EBD control)", is executed by a computerized device operating a plurality of solenoid valves in a hydraulic circuit. Examples of devices executing EBD control are seen in Japanese Laid-Open Patent Publications (JP) Nos. 5-213169 and 2001-219834.

[0003] Under EBD control, a demand from a driver of a vehicle for increasing braking force (e.g. a depression of a brake pedal) is modified for the restriction of braking force on rear wheels, which would cause the reduction of the total braking force. Thus, the driver would feel that the actually generated braking force is incompatible with his braking operation. In order to eliminate this feeling of the incompatibility while maintaining the braking performance and behavior of a vehicle, JP No. 2001-219834 discloses an EBD control device, in which, after once restricted, braking force on rear wheels is pulsatively increased in response to the increase of a braking action by a driver under a certain running condition. For preventing the locking of rear wheels, however, braking force on the rear wheels could not be increased limitlessly.

[0004] Accordingly, it is preferable that, in BFD control device, total braking force on a vehicle body may be rendered as close to the amount requested by a driver of the vehicle as possible, without inducing the locking of the rear wheels and the instability in the vehicle attitude induced therefrom.

[0005] Further, in the above-mentioned device, auxiliary braking control, such as Braking Assist Control (BAC) to be operated simultaneously with BFD or EBD control is not taken into account. Such auxiliary braking control is for increasing braking pressure beyond the amount requested from a driver of a vehicle so as to assist the driver to keep her/his vehicle stable, so that BFD control should be executed compatibly with any auxiliary braking control without reducing its effect.

[0006] Accordingly, a BFD control device may be improved more appropriately in conjunction with auxiliary braking control.

40

Summary of Invention

[0007] According to the present invention, there is provided a novel braking control device for a vehicle executing braking force distribution control. The control device may be designed to apply an operational fluid pressure in a master cylinder to wheel cylinders provided for the respective wheels (e.g. through a hydraulic circuit), producing braking force on the corresponding wheels under a normal condition. Under a certain operational condition of the vehicle, however, the control device starts restricting the increase of braking force on the rear wheels or holds the rear wheel cylinders at a holding pressure, determined based upon vehicle's running conditions, while increasing braking force on the front wheels depending upon the restricted amount of the braking force on the rear wheels. The holding of the rear wheel cylinders at the holding pressure may be done by closing valves in the lines to the rear wheel cylinders, for example. The BFD control may be started when the pressure in the rear wheel cylinder, the deceleration of the vehicle and/or the difference of slippage between the front and rear wheels reaches the corresponding predetermined value. During the execution of BFD control, further increment of braking force requested on a vehicle body will be added into the front wheels.

[0008] In accordance with this novel BFD control, braking force increased on a front wheel can compensate for the shortage of the braking force on the rear wheels, ensuring the generation of total braking force to be applied on a vehicle body. The increment in the front wheel braking pressure corresponds to the restricted amount of braking force on the rear wheels, so that the total braking force on the vehicle body can be rendered in conformity with the amount

requested by a driver of the vehicle without inducing the locking of the rear wheels and instability in the vehicle attitude induced therefrom.

5 [0009] The increment in the front wheel braking force, required through this control, may be estimated based upon a rear wheel braking pressure. In this regard, braking force generating apparatuses for the front and rear wheels, even supplied with operational fluid from a master cylinder at the same pressure, exhibit different braking performances, which decreases with the increase of a vehicle speed. Thus, in derivation of the increment to be added into the front wheel braking pressure, an amount of a braking action by a driver of the vehicle and parameters indicating braking performances of braking force generating apparatuses of the front and rear wheels will be taken into account. Then, the precise and appropriate control of the front wheel braking force is allowed based upon pressures in a hydraulic circuit of a braking system. In this connection, for reflecting the vehicle-speed dependence of the performance of the braking force generating apparatus in the control, preferably, the braking performance indicated by the parameters should have the same vehicle-speed dependence of decreasing with the increase of a vehicle speed. For a parameter of such braking performances, useful is a vehicle speed-dependent, braking effectiveness factor of a front wheel upon a vehicle.

10 [0010] Further, preferably, the amount of rear wheel braking force to be decremented or the holding pressure may be determined based upon a vehicle speed, a deceleration and/or other vehicle running condition at the starting of BFD control.

15 [0011] In another aspect of the present invention, there is provided a novel control device for braking a vehicle having front and rear wheels, a braking system generating braking forces on the respective wheels; at least a sensor monitoring an operational condition of the vehicle including a detector detecting an amount of braking action by a driver of the vehicle. In response to a variation of the operational condition monitored by the sensor, the control device executes braking force distribution control in which braking force on the rear wheels is lowered in comparison with those on the front wheels while the braking forces on the front wheels is increased based upon an increment of the braking action amount by the driver, detected by the detector. Namely, further increase in the braking action after the starting of BFD control is reflected in the front wheel braking force.

20 [0012] During execution of auxiliary braking control for increasing braking force on wheels beyond braking force corresponding to the amount of braking action by the driver, the braking force on the front wheels is increased based upon the increment in the braking action amount by the driver plus an increment in braking force requested by the auxiliary braking control. The auxiliary braking control may be braking assist control to be executed when an abrupt or full braking action is done by the driver.

25 [0013] As described above, during execution of auxiliary braking control such as BAC, total braking force on a vehicle body exceeding the amount requested from a driver of a vehicle is preferable or required for assisting the driver to keep her/his vehicle stable. In accordance with the present invention, by taking into account the increment requested by the auxiliary braking control as well as the demand of the driver (e.g. the master cylinder pressure), the increment in the front wheel braking force can compensate for the shortage in the total braking force due to the restriction of the rear wheel braking force in the BFD control, generating the total braking force expected by the auxiliary braking control as well as the driver demand, without the locking of the rear wheels prior to the front wheels, and thereby providing a more appropriate running condition of the vehicle than ever.

30 [0014] Typically, braking force on wheels are adjusted through a hydraulic circuit connected with a master cylinder and braking force generating apparatus, including wheel cylinders, provided for the respective wheels. In absence of BFD control, braking pressure for rear wheel would be equal to a current master cylinder pressure plus the pressure increment requested by auxiliary braking control. Thus, in order to compensate for the restricted or decremented amount of the braking force on the rear wheels, the increment in the front wheel braking pressure may be calculated based upon a difference between a current master cylinder pressure plus an increment in braking pressure requested by auxiliary braking control and a holding pressure for the rear wheels (or a master cylinder pressure at the starting of BFD control). When no auxiliary braking control is executed, the increment in braking pressure requested by auxiliary braking control is to be neglected, of course.

35 [0015] Further, if the pressure increments for the front and rear wheels are different from each other, preferably, the increment in braking pressure requested by auxiliary braking control used in the above- mentioned calculation is the pressure increment requested for the rear wheel, in view of the purpose of compensating for the reduction in braking force of the rear wheels.

40 [0016] The present invention is successfully applied to a hydraulic braking system, typically employed in a four-wheeled vehicle, having valves provided for individual wheel cylinders for adjusting the respective braking pressure and at least a common hydraulic line for applying braking pressure from a pressure supply to the wheel cylinders. More specifically, such a braking system has dual circuits, the one for front wheels and the other for rear wheels (front and rear (F-R) dual circuits), or the one for front-left and rear-right wheels and the other for front-right and rear-left wheels (cross (X) dual circuits), each circuit having a common line, the pressure in which is controlled with a single valve, which may be a linear solenoid valve.

[0017] Thus, it is an object of the present invention to provide new and novel devices for controlling a brake of a vehicle for executing braking force distribution among front and rear wheels of the vehicle, rendering the braking force on a rear wheel smaller than on a front wheel under a certain condition, and thereby, ensuring the generation of total braking force requested on the vehicle while avoiding the locking of the rear wheels prior to a front wheel and deterioration of the vehicle's attitude stability.

[0018] It is another object of the present invention to provide such devices restricting the increase of braking force on rear wheels while increasing the braking force on front wheels, compensating for the shortage in total braking force on the vehicle.

[0019] It is a further object of the present invention to provide such devices wherein the increment to added in braking force on front wheels is derived based upon the decrement in braking force on rear wheels through calculation of braking pressures in a hydraulic braking system of a vehicle.

[0020] It is a further object of the present invention to provide such devices wherein braking force distribution control is executed, taking into account auxiliary braking control, if any, as well as a braking action by a driver of a vehicle.

[0021] It is another object of the present invention to provide such devices that ensures generation of braking force on a vehicle requested by a driver and auxiliary braking control, if any, without the locking of a rear wheel prior to a front wheel.

[0022] It is another object of the present invention to provide such devices that executes braking force distribution control compatible with auxiliary braking control such as braking assist control, ensuring generation of total braking force requested on a vehicle while avoiding the locking of a rear wheel prior to a front wheel.

[0023] Other objects and advantages of the present invention will be in part apparent and in part pointed out hereinafter.

Brief Description of the Drawings

[0024] In the accompanying drawings,

Fig. 1A is a schematic diagram of a hydraulic circuit in a braking control device for a four-wheeled vehicle of a preferred embodiment according to the present invention;

Fig. 1B is a schematic diagram of an electronic controller in a braking control device for operating the components in the hydraulic circuit shown in Fig. 1A;

Fig. 2 is a schematic, sectional view of a pressure regulating valve employed in the hydraulic circuit shown in Fig. 1A;

Fig. 3A shows a phase diagram of condition of braking force distribution among front and rear wheels, showing an ideal braking force distribution line (two-dotted line), an actual braking force distribution line (thin solid line) in a case that the same braking pressure is applied to the front and rear wheels; and a braking force distribution line obtained in a preferred embodiment of the present invention;

Fig. 3B shows graphs of the relations between braking pressures P_f , P_r in front and rear wheels and master cylinder pressure P_m under braking force distribution control of a preferred embodiment of the present invention;

Fig. 4A shows a map of basic holding pressure for rear wheels P_{cs} vs. a vehicle speed V , used in calculation of the basic holding pressure;

Fig. 4B shows a map of a correction pressure ΔP_c vs. deceleration G_x , used in calculation of the correction pressure;

Fig. 5 shows a map of braking effectiveness factor of a front wheel on a vehicle vs. a vehicle speed, used in correction of the braking pressure increment for a front wheel;

Fig. 6 is a example of a flowchart executed in a braking force distribution control device of a preferred embodiment of the present invention.

Description of Preferred Embodiments

[0025] Fig. 1 illustrates a schematic diagram of a braking system implementing an embodiment of a control device for controlling braking force for a vehicle, enabling BFD control according to the present invention, which braking system consists of a hydraulic circuit 10 (Fig. 1A), transmitting a pressure in a master cylinder 14 (master cylinder pressure) to wheel cylinders 26i (i = FL, FR, RL, RR = front-left, front-right, rear-left and rear-right wheels, respectively) in braking force generating apparatuses provided for the respective wheels (not shown), and an electronic controller 90 (Fig. 1B) controlling brake fluid flows in the hydraulic circuit by operating solenoid valves and other components therein.

[0026] Referring to Fig. 1A, the illustrated hydraulic circuit 10 are of Front-Rear dual circuit type, having two circuits, the one 10F for a pair of front left and right wheel cylinders 26FL, 26FR and the other 10R for a pair of rear left and right wheel cylinders 26RL, 26RR. It should be noted that the two circuits may have the same piping structure, otherwise noted (In an actual braking system, these may be different from each other, of course).

[0027] As usual, a braking action of a driver of the vehicle, e.g. by depressing a brake pedal 12, pressurizes brake fluid in the master cylinder 14, compartmentalized into master cylinder chambers 14F and 14R with a free piston 16 movably supported with springs. To each chamber 14F, R connected is a common line 18F, R of the corresponding circuit 10F, R, respectively, leading to two branches 20i connected to the respective wheel cylinders 26i. In each branch 20i, there is provided a two-state, normally opened, solenoid valve 28i, selectively allowing brake fluid from the common line 18F, R (i.e. from the master cylinder 14) to flow into the respective wheel cylinder 26i, and thereby the wheel cylinder 26i will be selectively pressurized or held at a pressure by opening or closing the corresponding valve 28i. In order to avoid excessive pressurization of each wheel cylinder, a check valve 30i, allowing only flow from the wheel cylinder 26i to the common line 18F, R, is provided in parallel to the solenoid valve 28i. The branches 20i are also connected with buffer reservoirs 38 F, R, provided with the respective circuit 10F, R, via two-state, normally closed, solenoid valves 34i as shown, so that the pressure in each of the wheel cylinders can be selectively released by opening the corresponding valve 34i.

[0028] Each circuit 10F, R further comprises a normally opened, linear pressure regulation valve 22F, R in the corresponding common line 18F, R; a motor-driven pump 42F, R with a damper 48F, R, positioned between the reservoir 38F, R and the common line 18F, R; and a normally closed, solenoid valve 60 F, R selectively fluidly communicating the master cylinder chamber 14F, R to the corresponding pump input. These components are provided for regulating the pressure in the common line when braking pressure in a wheel cylinder 26i is to be increased beyond master cylinder pressure.

[0029] In detail, when the linear pressure regulation valve 22F, R and valve 60F, R are closed and opened, respectively, the master cylinder pressure is supplied to the pump input. Then, the pump 42F, R, when operated, pumps up brake fluid from the reservoir 38F, R and the master cylinder into the common line 18F, R. As described below in more detail, the linear pressure regulating valve 22F, R, when switched into a closed position, allows flow from the common line to the master cylinder only when the pressure in the common line exceeds a pressure determined by controlling the energization current supplied to solenoid coils in accordance with the controller 90. Further, since the master cylinder pressure is supplied through the valve 60F, R to the pump input, the pressure in the common line will not be lowered below the master cylinder pressure. A check valve 24F, R, connected in parallel with the regulating valve 22, also prevents the common line pressure from lowering below the master cylinder pressure. Accordingly, the pressure in the common line 18F, R is regulated at a pressure beyond the master cylinder pressure under the control of the controller 90.

[0030] Check valves 44F, R, 46F, R and 52F, R may be provided for avoiding any flow in undesirable directions. The damper 48F, R may be provided for smoothing out the pump output.

[0031] Referring to Fig. 1B, Electronic controller 90 incorporates a microcomputer 92, which may be of an ordinary type including a central processor unit, a read only memory, a random access memory, input and output port means and a common bus interconnecting these elements (not shown). The microcomputer 92 receives a signal of master cylinder pressure P_m , from a master cylinder pressure sensor 96 provided near the master cylinder 14; a signal of a vehicle speed V from a vehicle speed sensor 98; a signal of a vehicle longitudinal deceleration G_x from a longitudinal deceleration sensor 100; signals of wheel speeds V_{wi} from the respective wheel speed sensors 102i; calculates target braking pressures P_{ti} ($i = FL, FR, RL, RR$) and operates the valves, pumps, etc. through a driving device 94 in accordance with a control flow and related data, memorized in the microcomputer, as explained about later. The sign of the deceleration signal G_x is defined as positive in the direction decreasing the vehicle speed.

[0032] Fig. 2 shows a schematic diagram of the linear pressure regulating valve 22F(R), incorporating the check valve 24F(R), provided in each common line 18F, R. As shown, the valve comprises a housing 72 receiving an inlet line 18I connected to the master cylinder chamber 14F(R) and an outlet line 18O leading to the common line 18F(R) for the wheel cylinders 26i; a valve chamber 70; a valve body 74 movable up and down in the valve chamber; and solenoid coils 82. The inlet and outlet lines 18I, 18O are opened to the valve chamber 70 through internal lines 76 and 78, respectively.

[0033] In the absence of energization of the solenoids 82, the valve body 74 is biased downwardly by a compression spring 84, opening an aperture 80 of the internal line 78 for the outlet line 18O and rendering the common line 18F(R) exposed to the master cylinder pressure. When the solenoids is energized, the valve body is moved upwardly against the spring force, closing the aperture 80 and shutting out the fluid communication between the master cylinder and common line. Since, however, the common line is pressurized with the pump 42F(R), the valve body opens the aperture when the sum of the spring force and the pressure in the common line exceeds the sum of the master cylinder pressure and the electromagnetic force moving the valve body upwardly, allowing the flow from the common line to the valve chamber 70. Accordingly, the pressure in the common line 18 F(R) will be regulated by adjusting the energization current supplied to the solenoids. In this connection, for ensuring this pressure regulation in the common line, the check valve 24F(R), consisting of a valve ball biased by a spring for closing an aperture 88 opened to the valve chamber 70, is provided in parallel, allowing only the flow from the valve chamber to the common line in order to maintain the common line pressure at or above the master cylinder pressure. (The pressure regulation would not work if the common line pressure is lowered below the master cylinder pressure, because the flow from the valve chamber 70 to the common

line 180 would occur upon opening the aperture 80.)

[0034] In operation, the valves in the hydraulic circuit 10 are positioned as shown in Fig. 1A under normal condition (in the absence of BFD). Thus, the master cylinder pressure is directly reflected in the whole wheel cylinders 26i: The wheel cylinder pressures P_{wi} are substantially equal to the master cylinder pressure P_m .

[0035] However, when it is judged that BFD control is to be started in response to the depression of the brake pedal, etc. (the conditions requiring BFD are explained below in more detail), the valve 28RL, RR in the circuit 10R are closed, isolating the rear wheel cylinders 26RL, RR and holding them at a holding pressure P_c to be determined in a manner as described below. Further, in the circuit 10F, the regulating valve 22F and the valve 60F are closed and opened, respectively, and the pump 42F is operated. Then, only the pressures in the common line 18F and wheel cylinders 26FL, FR are varied for generating braking force on the respective front wheels by adjusting the energization current fed to the solenoids in the valve 22F with the controller 90.

[0036] Consequently, in this embodiment of the present invention, during execution of BFD control, the rear wheel cylinders are held at the holding pressure in order to prevent the locking of the rear wheels prior to the front wheels: the increase in the braking action by the driver after starting of BFD control is reflected only in the pressure in the front wheel cylinders. Under this condition, the front wheel braking pressure is increased beyond the master cylinder pressure, compensating for the shortage in the braking force due to the restriction of the pressure increase in the rear wheel cylinder.

[0037] Before starting of BFD, if an auxiliary braking control such as BAG has been operated to increase the wheel cylinder pressure beyond the master cylinder pressure, the pressure regulating valves 22F, R and valves 60F, R have been closed and opened, respectively, and the pumps 42F, R operated. Accordingly, the rear wheel cylinder pressure is substantially equal to the master cylinder pressure plus the increment requested by BAC. When the BFD control is to be executed under condition, the valves 28RL, RR are closed to hold the rear wheel cylinders at the current pressure therein, and thereafter, the front wheel braking pressure is controlled with the pressure regulating valve 22F.

[0038] With reference to Figs. 3A and 3B, a control strategy in the embodiment of the present invention will be explained below.

[0039] Fig. 3A shows a phase diagram of a condition of braking force distribution among front and rear wheels, where the theoretically obtained ideal BFD line, well known in the art, (two-dot dashed line) and an actual BFD line (thin solid line) are drawn.

[0040] The ideal BFD line indicates a condition in which braking force is so distributed among the front and rear wheels that the front and rear wheels are simultaneously locked (Detailed of this line is described elsewhere). Thus, if a condition of braking force distribution is above this line, the possibility that a rear wheel will be locked prior to front wheels will be high.

[0041] The actual BFD line indicates condition in which the same pressure is applied to the wheel cylinders when a vehicle runs at a certain speed. As shown, the actual BFD line linearly increases below the ideal line and intersects with the ideal line at a certain point F_c . Thus, further increase in the rear wheel braking force along the actual line would induce the locking of the rear wheel prior to the front wheels. In order to avoid this, in the embodiment, the rear wheel braking force should be held at the force of the intersecting point F_c , i.e. further increase of the rear wheel braking force is restricted. The force F_c corresponds to a holding pressure P_c . As seen from Fig. 3A, further increase of the total braking force under the condition that the rear wheel braking force would exceed F_c , the master cylinder pressure P_m exceeds the holding pressure ($P_m > P_c$) is reflected in the front wheel braking force or pressure as shown in the thick line.

[0042] In this connection, it has been revealed practically that, when the vehicle speed increases, the ratio of the braking effectiveness of a front wheel to that of a rear wheel is reduced: the decrement of the braking force on a rear wheel due to the increase of the vehicle speed is smaller than that on the front wheel if the same braking pressure is applied to those wheel cylinders. Accordingly, the actual line is brought closer to the rear wheel axis (ordinate) and the intersecting point F_c is shifted toward 0 along the ideal BFD line, resulting in that the holding force or pressure F_c , P_c should be decreased with the increase of the vehicle speed.

[0043] Further, the ideal BFD line is shifted upwardly as a vehicle weight increases. In such a case, as seen from the phase of Fig. 3A, it is preferable that the holding pressure is to be increased, thereby allowing the generation of larger braking force on rear wheels without exerting excessive load on the front wheels. In order to take into account the effect of the vehicle weight on the braking force distribution, the holding pressure determined based upon the vehicle speed is preferably modified to increase as the deceleration decreases. (Supposing a certain braking force is exerted on a vehicle, the deceleration is decreased as the vehicle weight (mass) increases: Braking force = Mass x Deceleration.)

[0044] Practically, in the present embodiment, the holding pressure P_c may be determined as a function of a vehicle speed V and a deceleration G_x by using maps of Basic holding pressure P_{cs} vs. Vehicle speed V as shown in Figs. 4A and Correction pressure ΔP_c vs. Deceleration G_x as shown in 4B as follows:

$$P_c = P_{cs} + \Delta P_c. \quad (1)$$

These maps may be obtained experimentally or theoretically and memorized in the microcomputer 92. In Fig. 4B, G_{x0} , where $\Delta P_c = 0$, may be a standard deceleration generated on a standard weighted vehicle during braking.

[0045] In accordance with the holding of the rear wheel braking pressure, the total braking force to be exerted for the vehicle will be short, while the locking of the rear wheel prior to the front wheel is prevented. Thus, in the embodiment of the present invention, the front wheel braking force is incremented for compensating for the shortage of the rear wheel braking force. With reference to Fig. 3B showing the braking pressures P_f , P_r in the front and rear wheel cylinders supplied with master cylinder P_m , the pressure P_f for the front wheels will be incremented by ΔP_f , i.e. $P_f = P_m + \Delta P_f$, while the rear wheel cylinder is held at P_c . The increment ΔP_f for the front wheels corresponds to the braking force that would be produced with the restricted amount in the rear wheel braking pressure ΔP_r , the difference between P_m and P_r ($=P_c$).

[0046] Practically, the increment ΔP_f will be determined as a function of the decrement of the rear wheel braking pressure, i.e. the difference between the master cylinder pressure and holding pressure: $P_m - P_c$, taking into accounts braking performances of the front and rear wheels and the vehicle speed-dependent braking effectiveness of the front wheels for the vehicle body as described in the followings.

[0047] Firstly, a braking force increment on the front wheel ΔF_f is equal to a force decrement on the rear wheel ΔF_r . ΔF_f and ΔF_r are given by:

$$\Delta F_f = \Delta P_{f0} \times (S_f \times R_f \times BEF_f)$$

$$\Delta F_r = \Delta P_r \times (S_r \times R_r \times BEF_r)$$

where ΔP_{f0} is a basic front wheel braking pressure increment (before corrected with the braking effectiveness dependent upon a vehicle speed); S_f , S_r , sectional areas of the front and rear wheel cylinders; R_f , R_r , braking effective radii for the front and rear wheels; and BEF_f , BEF_r , braking effectiveness factors for the front and rear wheels. The sectional areas and braking effective radii are determined by specifications of the front and rear wheel braking force generating apparatus, and the braking effectiveness factors are experimentally obtained.

[0048] Since $\Delta F_f = \Delta F_r$ is to be established, the basic front wheel braking pressure increment is given by:

$$\begin{aligned} \Delta P_{f0} &= \Delta P_r \times (S_r \times R_r \times BEF_r) / (S_f \times R_f \times BEF_f) \\ &= (P_m - P_c) \times (S_r \times R_r \times BEF_r) / (S_f \times R_f \times BEF_f) \end{aligned} \quad (2).$$

[0049] Secondly, it has been experimentally revealed that the braking effectiveness factor of the front wheel pressure for a vehicle body, BEF , is decreased dependent upon a vehicle speed as shown in a map of Fig. 5. Thus, the basic front wheel pressure increment may be modified as follows:

$$\Delta P_f = \Delta P_{f0} \times (1 + \Delta BEF / BEF_0) \quad (3)$$

where BEF_0 is a reference braking effectiveness, measured at a predetermined reference speed; and ΔBEF , a deviation of the effectiveness at current speed from the reference. The calculations of expressions (2) and (3) are executed in real time with the microcomputer 92 in which all the required factors, constants and the map can be memorized to be used.

[0050] As is not shown here, a braking effectiveness of a rear wheel on the vehicle may be modified similarly with respect to its dependency upon a vehicle speed.

[0051] As noted, the front wheel braking pressure is adjusted to $P_m + \Delta P_f$ through controlling the energization current fed to the pressure regulating valve 22 and operating the pump 42.

[0052] By the way, auxiliary braking force control such as BAC, if any, will request increasing braking pressures for the wheels beyond the master cylinder pressure, in order to obtain higher braking force than requested directly by a driver's braking action. BAG is executed, for example, when a driver makes an abrupt and relatively high braking action (in practical, when the master cylinder pressure and its differential each exceed the respective predetermined reference values.). Since the rear wheel braking pressure is held at the holding pressure P_c for avoiding the locking of rear wheels

EP 1 466 798 A1

prior to front wheels irrespective of the presence of such BAC, the increment of braking force requested by BAC that would be added to the rear wheels should be compensated in the front wheels for reflecting the effect of BAC in the total braking force on the vehicle.

[0053] Practically, the pressure increment of braking assist control for the rear wheels ΔP_{bar} is added into the basic pressure increment for the front wheel as follows:

$$\Delta P_{fo} = (P_m + \Delta P_{bar} - P_c) \times (S_r \times R_r \times BE_{Fr}) / (S_f \times R_f \times BE_{Ff}) \quad (4)$$

and therefore,

$$P_f = P_m + \Delta P_{baf} + \Delta P_f \quad (5)$$

where ΔP_{baf} is the pressure increment of braking assist control for the front wheel. ΔP_f in exp. (5) may be modified through exp. (3) with respect to the vehicle speed-dependency of the braking effectiveness on a vehicle body. It should be noted that the increment of BAC requested before the starting of the BFD control has been taken into account in the holding pressure P_c .

[0054] Consequently, even during the execution of BFD control, BAC is effective without losing or reducing the total braking force to be applied on the vehicle body. It should be noted that a pressure increment through other auxiliary braking control such as HAB may be incorporated similarly.

[0055] Typically, BFD control for holding the rear wheels at the holding pressure P_c may be started when the master cylinder pressure P_m reaches to the holding pressure P_c on the assumption that the rear wheel braking pressure P_r is nearly equal to the master cylinder pressure in absence of BFD control and any other control for modifying braking pressure. As described above, when BAC has been already executed before starting of BFD, the rear wheel braking pressure P_r is nearly equal to the sum of P_m and ΔP_{bar} . Thus, the rear wheel cylinders are held when the sum of P_m and ΔP_{bar} reaches to the holding pressure P_c .

[0056] Further, the BFD control may be started in response to other conditions, for instance, when the deceleration G_x exceeds a reference deceleration G_{xs} (a positive constant) for starting BFD control; when the difference between an average wheel speed of the front left and right wheels and that of the rear left and right wheels ($\Delta V_w = 1/2(V_{w-FL} + V_{w-FR} - V_{w-RL} - V_{w-RR})$) exceeds a reference speed V_{ws} (a positive constant) for starting BFD control; and when both the conditions of the deceleration and average wheel speed are established. When BFD is started to hold the rear wheel braking pressure in response to the conditions other than the master cylinder pressure, the pressure increment for the front wheels will be calculated by regarding the master cylinder pressure P_m at the holding as the holding pressure P_c irrespective of the maps of Figs. 4A and 4B.

[0057] Preferably, BFD control lasts as long as P_m , G_x , or ΔV_w exceeds P_c , G_{xs} or ΔV_w . In practical, the BFD control may be terminated when either or all of P_m , G_x and ΔV_w fall below the respective reference values, P_{me} (a positive constant); G_{xe} (a positive constant); and V_{we} (a positive constant). The reference values, P_{me} , G_{xe} , V_{we} are preferably rather smaller than the corresponding P_c , G_{xs} , V_{ws} , in order to avoid hunting in the control.

[0058] It should be realized that the conditions of the starting and ending of BFD control may be theoretically and/or experimentally determined in various manners known in the art.

[0059] In the followings, referring to Fig. 6, the operation of the braking force distribution control device, explained above with reference to Figs. 1A and 1B, will be described. The control according to a control routine shown in Fig. 6 is started by a closure of an ignition switch (not shown in Fig. 1) and cyclically repeated at a cycle time such as several milliseconds during the operation of the vehicle. In this routine, basically, before execution of BFD, the holding pressure P_c is calculated based upon current vehicle speed, etc. in every cycle. However, once the BFD is started, the rear wheel braking pressure is held and the variations of braking action by a driver and demand of BAC, if any, are reflected only in the front wheel braking pressure. Thus, in this case, steps of calculation of the holding pressure and judgment of the starting of BFD are bypassed until any condition for terminating the BFD is established.

[0060] Firstly, in step 10, the signals shown in Fig. 1B and the aforementioned parameters required in the following steps are read in. If BAC has been already executed, the parameters of the increments for the wheels ΔP_{baf} , ΔP_{bar} , determined by a BAC control process, have significant values. $\Delta P_{baf} = \Delta P_{bar}$ is possible.

[0061] In step 20, whether or not the BFD control has been already executed is judged. If BFD is not executed, a holding pressure P_c is determined in steps 30 - 50 based upon a vehicle speed V and a (the) deceleration G_x by using maps in Figs. 4A and 4B.

[0062] Next, in steps 60 and 70, it is detected if BFD is to be executed. When the master cylinder pressure plus the increment of BAC, if any: $P_m + \Delta P_{bar}$, regarded as a current rear wheel braking pressure, exceeds the holding pressure P_c (step 60) or when the other aforementioned condition for starting BFD is established, the judgment of starting of

BFD is done and steps 100-120 for calculating the target front wheel braking pressure will be executed by using the aforementioned equations (2)-(5) together with the map in Fig.5. In this connection, in the absence of BAC, ΔP_{baf} and ΔP_{bar} should be zero or ignored in the calculation. If the judgment of the starting of BFD is done in Step 70, the holding pressure P_c is re-defined to be the value regarded as the current rear wheel braking pressure: $P_c \leftarrow P_m + \Delta P_{bar}$.

5 [0063] Then, in accordance with the above result, the valves in the hydraulic circuit are operated in steps 130. Namely, the valves for isolating the rear wheel cylinders 28RL, RR are closed while the pressure regulating valve 22F and valve 60F are closed and opened, respectively, and the pump 42F is started. If BAC has been executed, the valves 28RL, RR are closed. Then, in order to control the front wheel braking pressure, the energization current corresponding to P_f is fed to the regulating valve 22F.

10 [0064] If either of conditions for starting BFD is not established in steps 60 and 70, the routine returns to Start without executing steps 100 - 130: without BFD control is not executed.

[0065] When BFD has been already executed in the judgment in Step 20, Step 90 is executed directly, in which it is detected if BFD is to be terminated by checking any establishment of the aforementioned conditions for terminating BFD. If BFD is to be terminated, the valves are operated so as to release the holding of the rear wheel braking pressure while ceasing the increase of the front wheel braking pressure beyond the master cylinder pressure. The process for releasing the holding may be done gradually e.g. by opening the valves 28RL, RR intermittently in order to avoid any abrupt variation of a pressure in a wheel cylinder.

15 [0066] If not in step 90, steps 100-130 is executed again, while bypassing steps 20 - 80. In step 130, the valves in the hydraulic circuit are operated so as to control only the front wheel braking pressure because the valves for holding the rear wheel cylinders have been closed in the previous cycle. Then, the process of the flowchart is restarted.

[0067] Although the present invention has been described in detail with respect to preferred embodiments thereof, it will be apparent for those skilled in the art that other various modifications are possible with respect to the shown embodiments within the scope of the present invention.

20 [0068] For instance, a braking system implementing the present invention may be of a type in which wheel cylinders for the respective wheels are independently controllable. As long as braking force is controllable beyond the braking force requested by a braking action by a driver, the present invention, in view of its features, is applicable to a braking system of any type.

[0069] In the afore-mentioned embodiment, braking force has the identical magnitude in each of pairs of front wheels and rear wheels. However, it should be realized that, depending upon a behavior and /or a turning condition of a vehicle, the left and right wheels in each pair of wheels may be controlled so as to generate different forces.

25 [0070] Further, the present invention is applicable to systems where a wheel cylinder pressure sensor for each wheels is provided.

[0071] In addition, in the present embodiment, rear wheel is held at the holding pressure by closing the corresponding valve. The pressure in a rear wheel cylinder (or front wheel cylinder), however, may be controlled for maintaining a holding pressure through operation of the corresponding valves (pulsative or dithering increase or decrease) in lines connected toward a common line and/or a reservoir. In this connection, the holding force and/or holding pressure for the rear wheel may be varied depending upon a vehicle speed and/or deceleration in every cycle of the control routine during BFD control.

30 [0072] It should be noted that values for a holding pressure, P_c , P_{cs} or ΔP_c and an increment for the front wheels ΔP_{fo} , ΔP_f may be determined differently without deviating the scope of the present invention. Although it is preferable to take into account vehicle speed- and deceleration-dependencies and other characteristics of these values for achieving a highly accurate and appropriate control, some of those characteristics may be ignored depending upon the required accuracy of the control and/or costs of manufacturing, operating and/or maintaining a device.

45 **Claims**

1. A device for controlling a braking of a vehicle having front and rear wheels, a braking system generating braking forces on the respective wheels, at least one sensor monitoring an operational condition of the vehicle including a detector detecting an amount of a braking action by a driver of the vehicle, the device executing a braking force distribution control in which braking force on the rear wheels is lowered in comparison with braking force on the front wheels when an operational condition monitored by a sensor among the at least a sensor stratifies a predetermined condition, **characterized in that** braking force on the front wheels during execution of the braking force distribution control is increased, where a braking force increment on the front wheel beyond braking force corresponding to the braking action is determined based upon an increment of the braking action by the driver detected by the detector and an increment of braking force requested by an auxiliary braking control for increasing the braking force on the wheels beyond braking force corresponding to the amount of braking action by the driver during execution of the auxiliary braking control in addition to execution of the braking force distribution control.

2. A device of claim 1, **characterized in that** the braking force increment on the front wheel is determined as a function of the braking force on the rear wheels.
- 5 3. A device of claim 1, wherein the braking system comprises a hydraulic circuit connected with a master cylinder and braking force generating apparatus including wheel cylinders provided for the respective wheels; the braking action is reflected in a pressure in the master cylinder pressure, **characterized in that**, during the execution of the auxiliary braking control in addition to the execution of the braking force distribution control, the braking force increment on the front wheels is determined based upon a difference between a current master cylinder pressure and a rear wheel cylinder pressure at the starting of the braking force distribution control and an increment of braking pressure requested by the auxiliary braking control; and in absence of the auxiliary braking control, the braking force increment on the front wheels is determined based upon a difference between a current master cylinder pressure and the rear wheel cylinder pressure at the starting of the braking force distribution control.
- 10 4. A device of claim 1, **characterized in that** the rear wheel cylinder pressure at the starting of the braking force distribution control is a sum of a master cylinder pressure and an increment of braking pressure requested by the auxiliary braking control to the rear wheels at the starting of the braking force distribution control during any auxiliary braking control is executed.
- 15 5. A device of claim 1, **characterized in that** the increment requested by the auxiliary braking control is that requested to the rear wheels when the increments requested to the front and rear wheel cylinders by the auxiliary braking control are different from each other.
- 20 6. A device of claim 1, **characterized in that** the braking force increment on the front wheels are substantially equal to the restricted amount of the braking force on the rear wheels.
- 25 7. A device of claim 1, **characterized in that** the auxiliary braking control is a braking assist control to be executed when an abrupt braking action is executed.
- 30 8. A device of claim 1, **characterized in that**, during execution of the braking force distribution control, the braking force on the rear wheels is held at a predetermined value.
- 35 9. A device of claim 3, **characterized in that**, during execution of the braking force distribution control, the pressures in the rear wheel cylinders are held at a predetermined pressure.

FIG. 1A

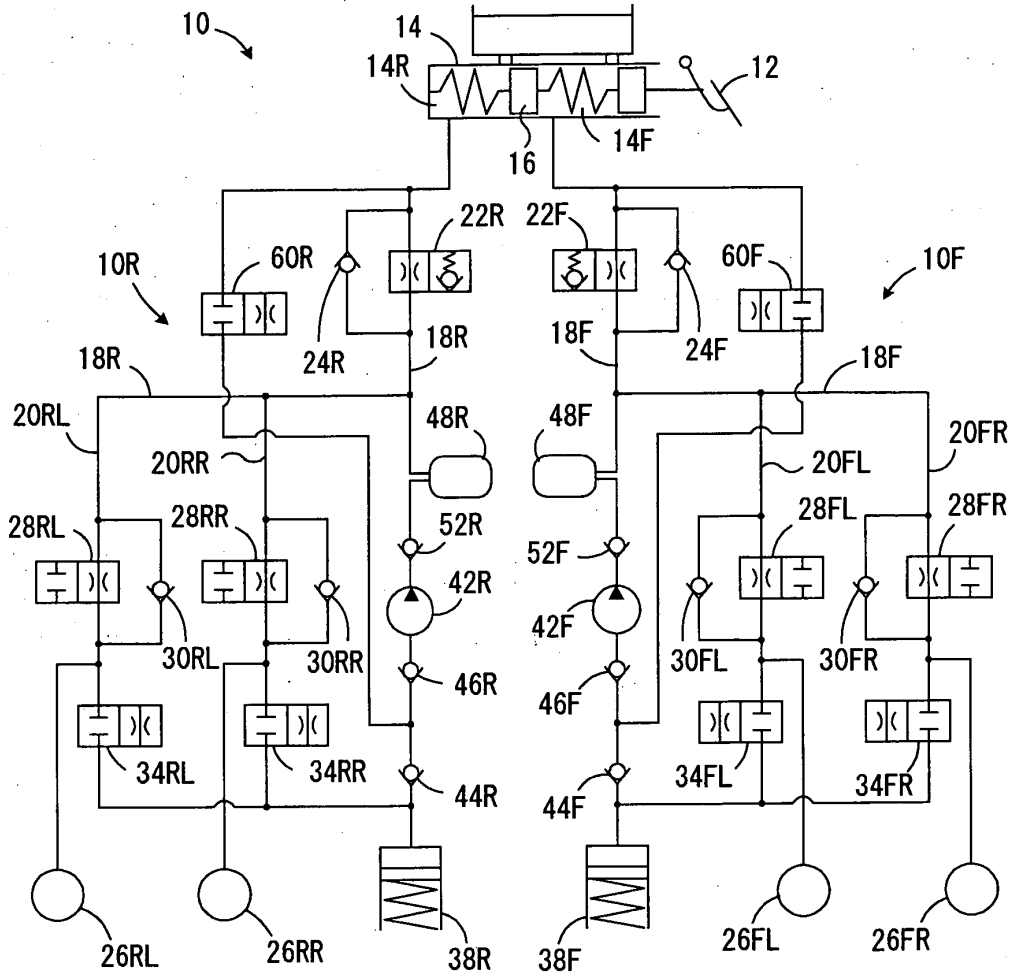

FIG. 1B

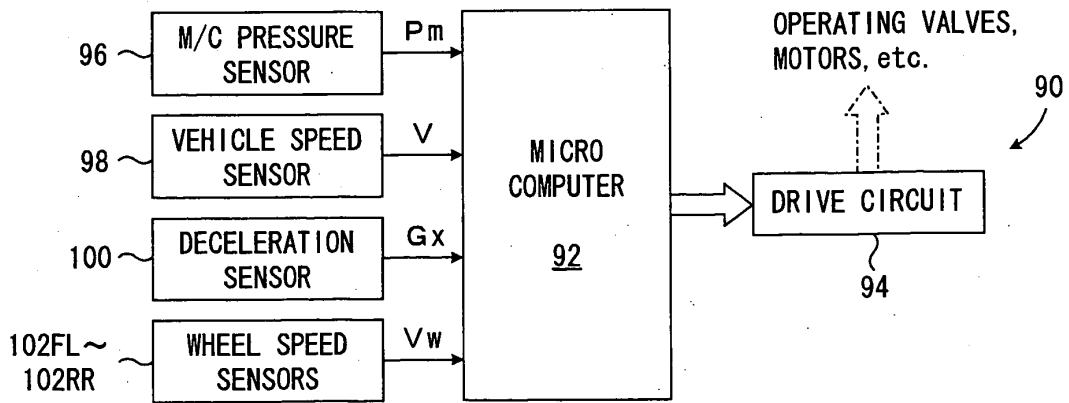

FIG. 2

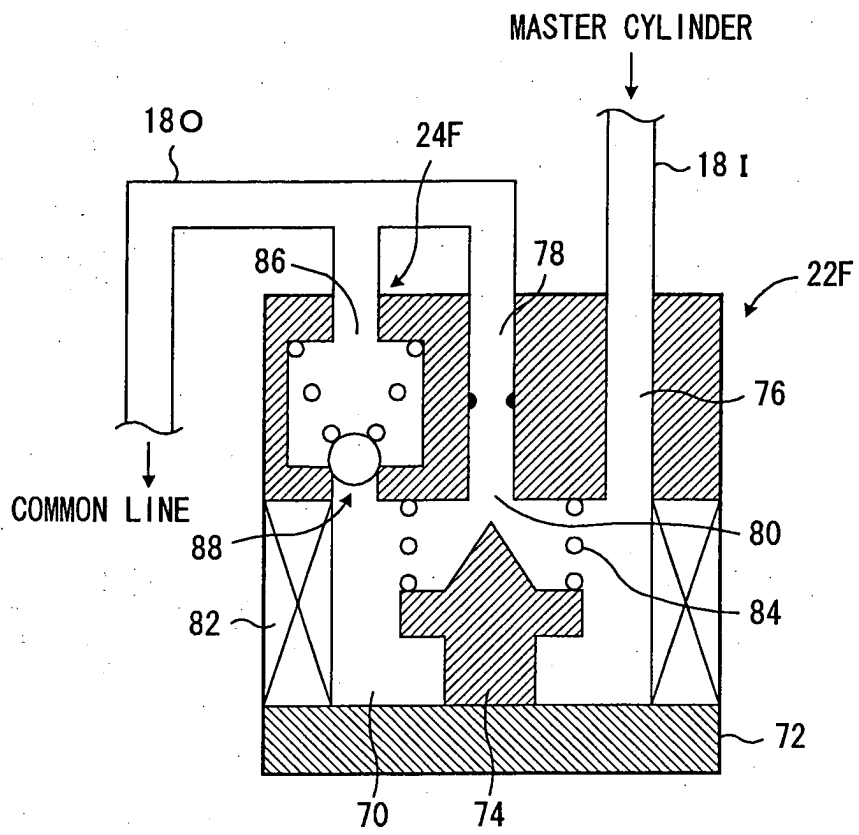

FIG. 3A

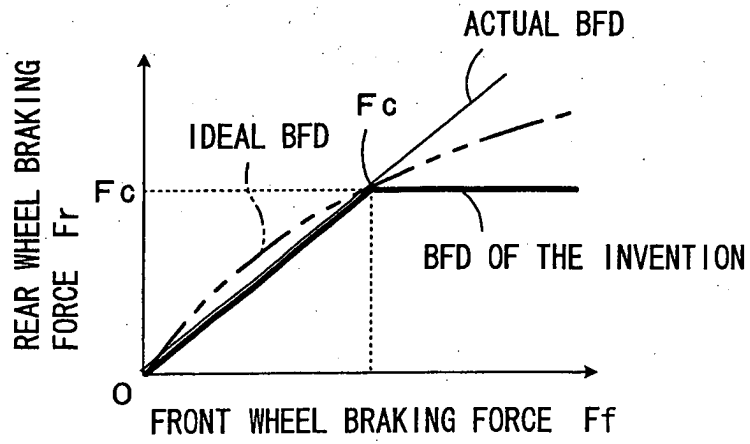

FIG. 3B

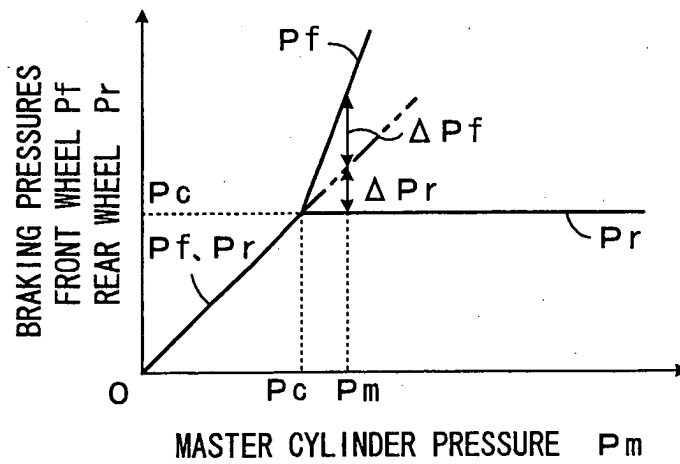

FIG. 4A

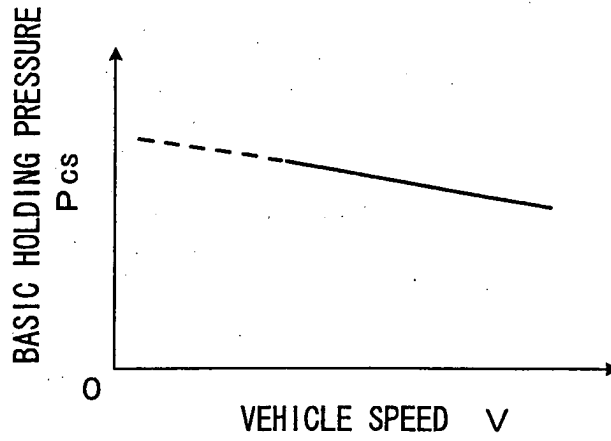

FIG. 4B

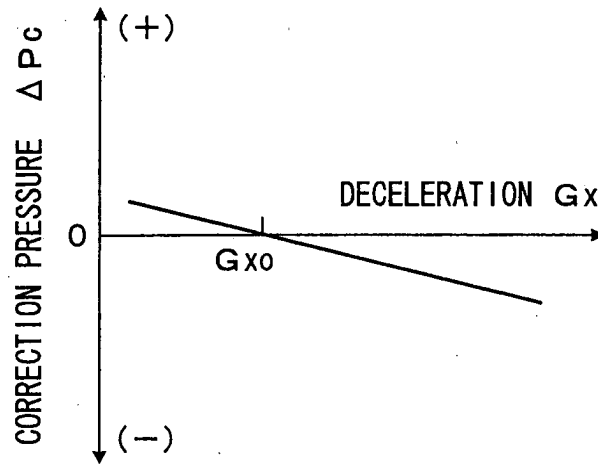

FIG. 5

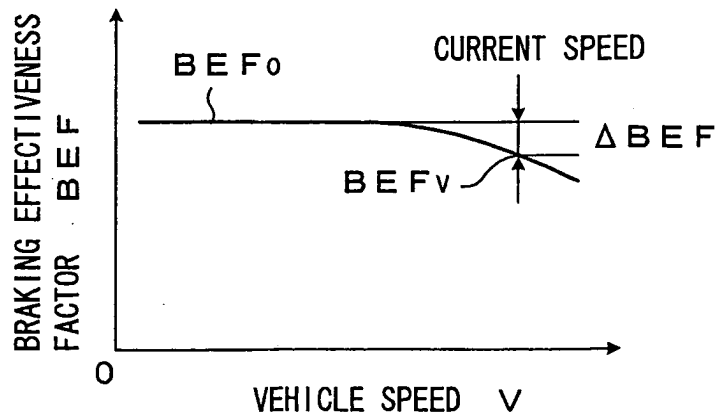
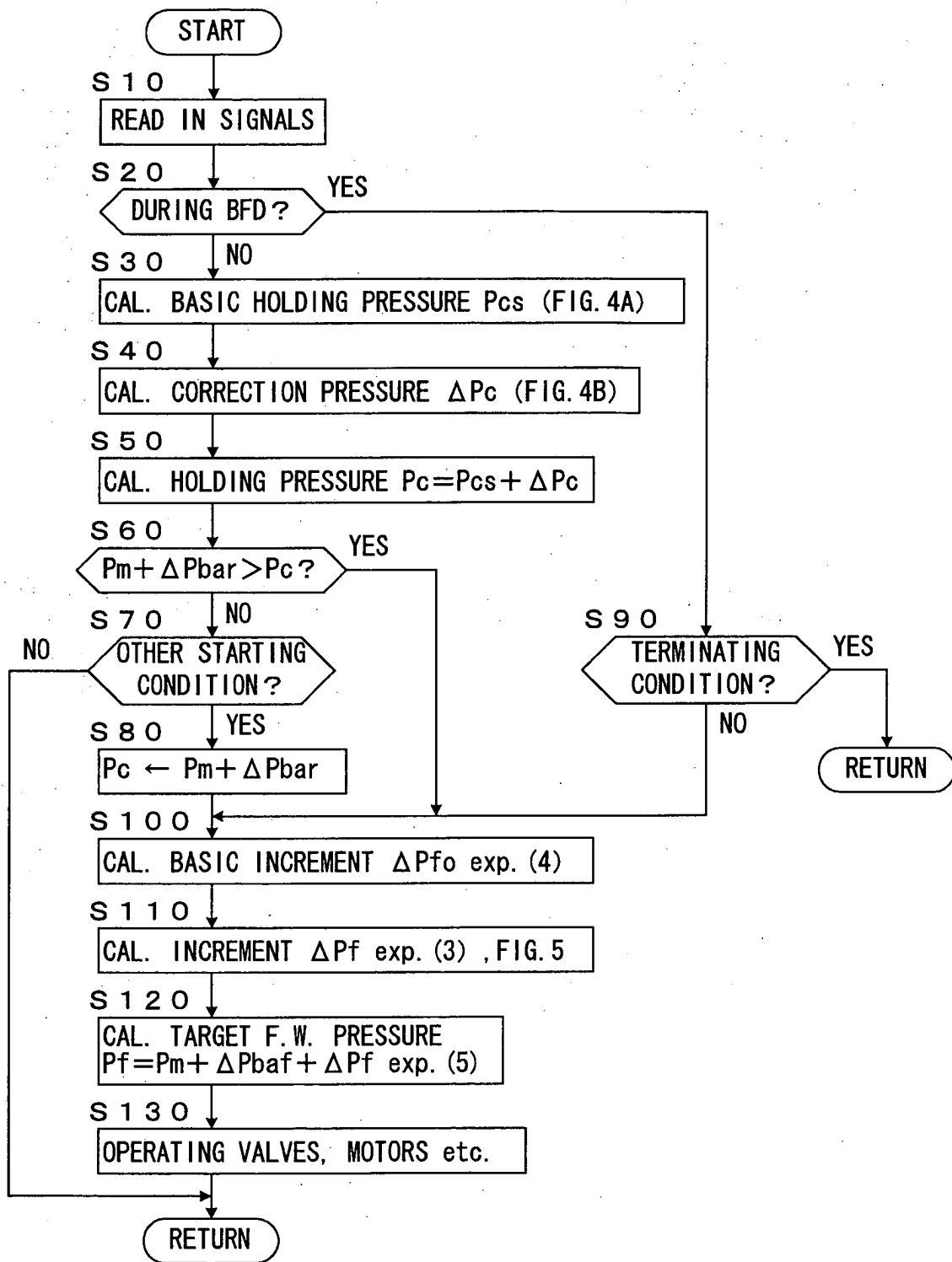

FIG. 6





European Patent
Office

EUROPEAN SEARCH REPORT

Application Number
EP 04 00 8344

DOCUMENTS CONSIDERED TO BE RELEVANT			
Category	Citation of document with indication, where appropriate, of relevant passages	Relevant to claim	CLASSIFICATION OF THE APPLICATION (Int.Cl.7)
X	US 2002/185913 A1 (WATANABE RYOCHI) 12 December 2002 (2002-12-12) * page 1, paragraph 3 - page 1, paragraph 10 * * page 5, paragraph 63 - page 6, paragraph 73 * * page 7, paragraph 80; figures 3,5-7 * -----	1,6	B60T8/00 B60T8/26 B60T8/32
X	DE 43 00 048 A (DAIMLER BENZ AG) 6 October 1994 (1994-10-06) * page 7, line 50 - page 8, line 10 * -----	1	
X	US 6 474 751 B1 (SAWADA MAMORU ET AL) 5 November 2002 (2002-11-05) * column 24, line 38 - column 26, line 49; figures 16,17B * -----	1	
X	PATENT ABSTRACTS OF JAPAN vol. 1995, no. 08, 29 September 1995 (1995-09-29) & JP 7 117655 A (NISSAN MOTOR CO LTD), 9 May 1995 (1995-05-09) * abstract * -----	1	
A	US 5 549 369 A (BRUGGER FRANZ ET AL) 27 August 1996 (1996-08-27) * column 1, line 59 - column 2, line 61; figure * -----	1-9	
The present search report has been drawn up for all claims			
Place of search		Date of completion of the search	Examiner
Munich		16 July 2004	Marx, W
CATEGORY OF CITED DOCUMENTS		T : theory or principle underlying the invention E : earlier patent document, but published on, or after the filing date D : document cited in the application L : document cited for other reasons ----- & : member of the same patent family, corresponding document	
X : particularly relevant if taken alone Y : particularly relevant if combined with another document of the same category A : technological background O : non-written disclosure P : intermediate document			

EPO FORM 1503 03 82 (F04C01)

**ANNEX TO THE EUROPEAN SEARCH REPORT
ON EUROPEAN PATENT APPLICATION NO.**

EP 04 00 8344

This annex lists the patent family members relating to the patent documents cited in the above-mentioned European search report. The members are as contained in the European Patent Office EDP file on The European Patent Office is in no way liable for these particulars which are merely given for the purpose of information.

16-07-2004

Patent document cited in search report	Publication date	Patent family member(s)	Publication date
US 2002185913 A1	12-12-2002	JP 2002362348 A	18-12-2002
		DE 10225870 A1	02-01-2003

DE 4300048 A	06-10-1994	DE 4300048 A1	06-10-1994

US 6474751 B1	05-11-2002	JP 9254762 A	30-09-1997
		JP 3518145 B2	12-04-2004
		JP 9254773 A	30-09-1997
		JP 3518146 B2	12-04-2004
		JP 9254774 A	30-09-1997
		JP 3518147 B2	12-04-2004
		JP 9254775 A	30-09-1997
		JP 9254776 A	30-09-1997
		JP 9263234 A	07-10-1997
		JP 3525625 B2	10-05-2004
		JP 9323641 A	16-12-1997
		JP 10119751 A	12-05-1998
		JP 9240455 A	16-09-1997
		JP 10274175 A	13-10-1998
		US 6142581 A	07-11-2000
		AU 690479 B2	23-04-1998
		AU 7650896 A	03-07-1997
		CA 2193924 A1	27-06-1997
		CN 1161290 A ,B	08-10-1997
		DE 69620734 D1	23-05-2002
		DE 69620734 T2	05-12-2002
		EP 1026059 A2	09-08-2000
		EP 1155933 A2	21-11-2001
		EP 0784002 A1	16-07-1997
		ES 2172625 T3	01-10-2002
		US 6024420 A	15-02-2000
		JP 9309427 A	02-12-1997
		DE 19804207 A1	06-08-1998
		DE 10104222 A1	09-08-2001
		JP 2001287638 A	16-10-2001

JP 7117655 A	09-05-1995	JP 2988223 B2	13-12-1999

US 5549369 A	27-08-1996	DE 4338065 A1	11-05-1995
		FR 2712247 A1	19-05-1995
		GB 2283792 A ,B	17-05-1995
		IT RM940717 A1	08-05-1995
		JP 2727163 B2	11-03-1998
		JP 7165051 A	27-06-1995

EPO FORM P0459

For more details about this annex : see Official Journal of the European Patent Office, No. 12/82