



US 20180067319A1

(19) **United States**

(12) **Patent Application Publication**
Border et al.

(10) **Pub. No.: US 2018/0067319 A1**
(43) **Pub. Date: Mar. 8, 2018**

(54) **OPTICAL CONFIGURATIONS FOR HEAD-WORN SEE-THROUGH DISPLAYS**

(52) **U.S. CI.**
CPC *G02B 27/0172* (2013.01); *G02B 27/283* (2013.01); *G02B 27/0176* (2013.01); *G02B 2027/0178* (2013.01); *G02B 5/30* (2013.01); *G02B 2027/0118* (2013.01); *G02B 2027/0152* (2013.01); *G02B 27/28* (2013.01)

(71) Applicant: **Osterhout group, Inc.**, San Francisco, CA (US)

(72) Inventors: **John N. Border**, Campbell, CA (US); **Joseph Bietry**, Chili, NY (US); **John D. Haddick**, Corte Madera, CA (US)

(21) Appl. No.: **15/724,297**

(57) **ABSTRACT**

(22) Filed: **Oct. 4, 2017**

Related U.S. Application Data

(60) Continuation of application No. 15/155,139, filed on May 16, 2016, now Pat. No. 9,798,148, which is a division of application No. 14/325,991, filed on Jul. 8, 2014, now Pat. No. 9,366,867.

An optical system for a head-worn computer includes an upper optical module adapted to convert illumination into image light by illuminating a reflective display through a field lens, wherein the image light is transmitted back through the field lens, then through a partially reflective partially transmissive surface and into a lower optical module adapted to present the image light to an eye of a user wearing the head-worn computer and the upper optical module being positioned within a housing for the head-worn computer and having a height of less than 24 mm, as measured from the reflective display to the bottom edge of the rotationally curved partial mirror.

Publication Classification

(51) **Int. Cl.**
G02B 27/01 (2006.01)
G02B 27/28 (2006.01)
G02B 5/30 (2006.01)

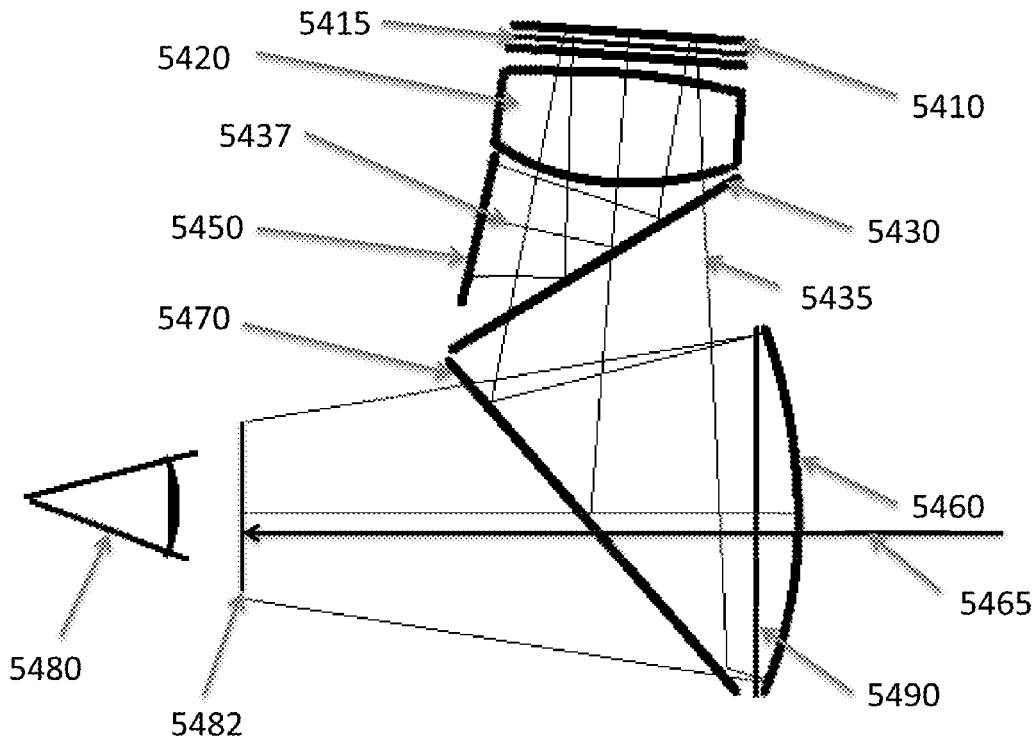

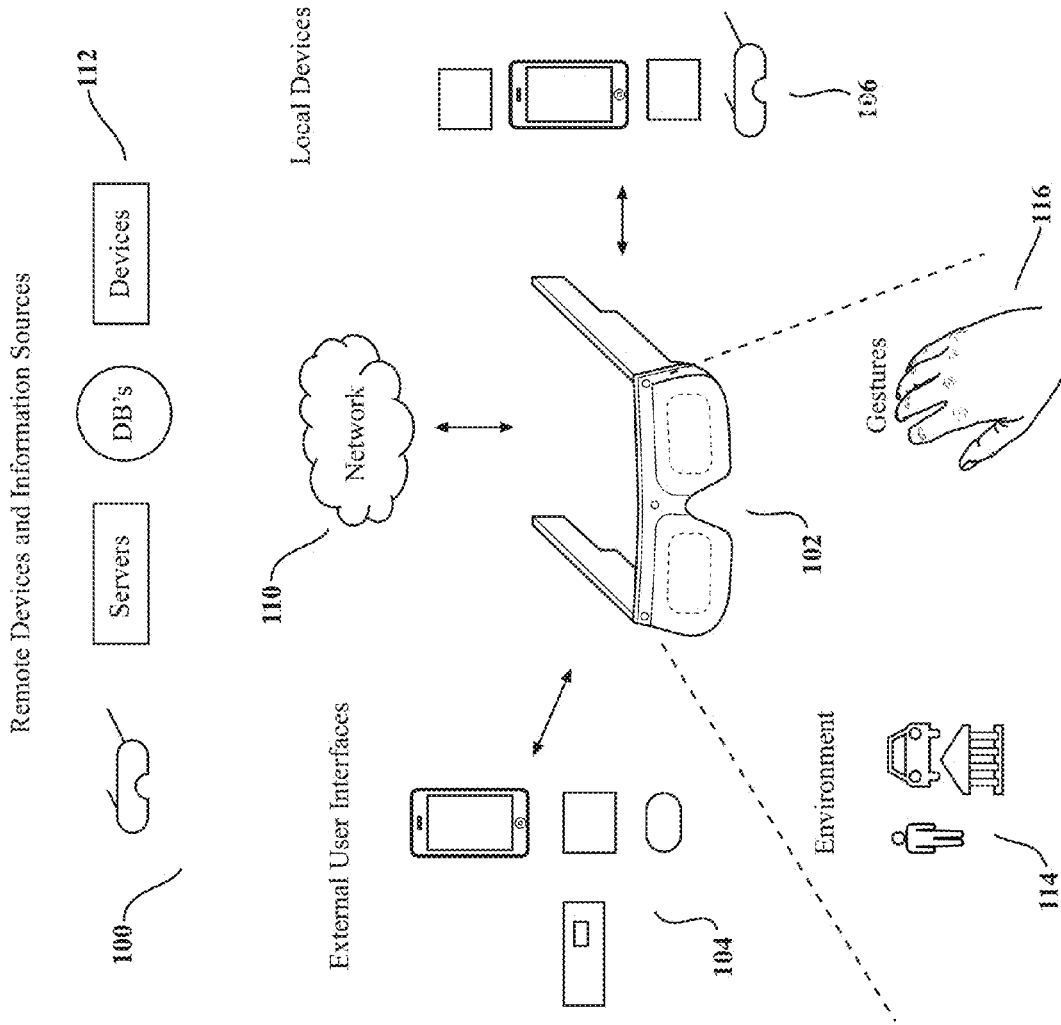

FIG. 1

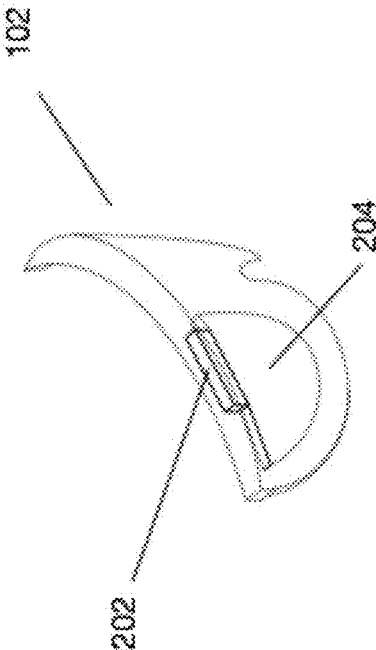
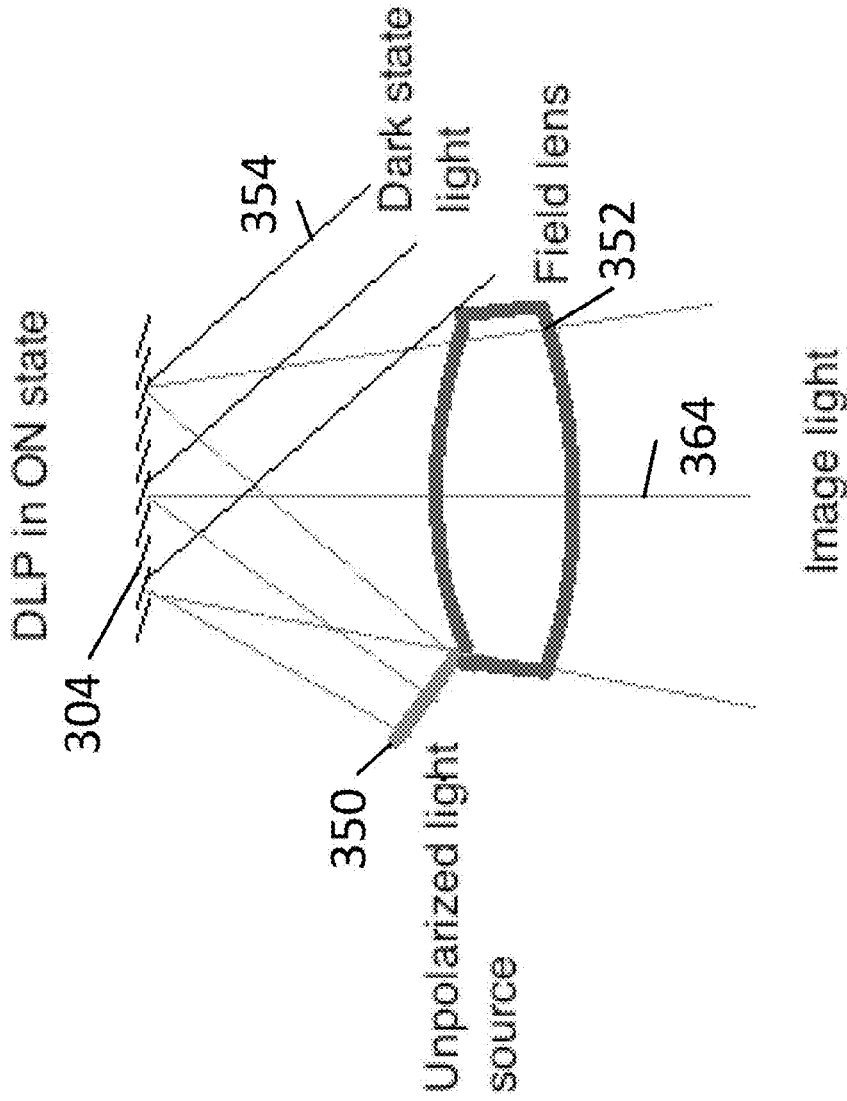

Figure 2



PRIOR ART
Figure 3a

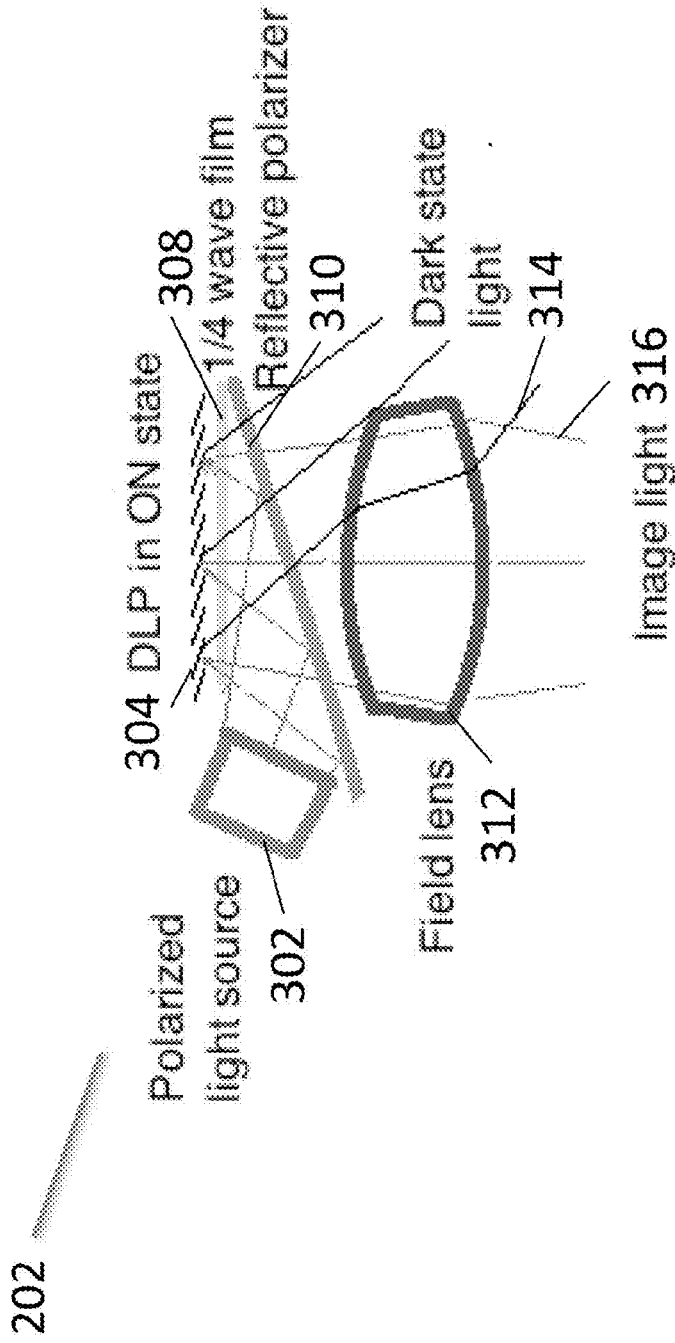

Figure 3b

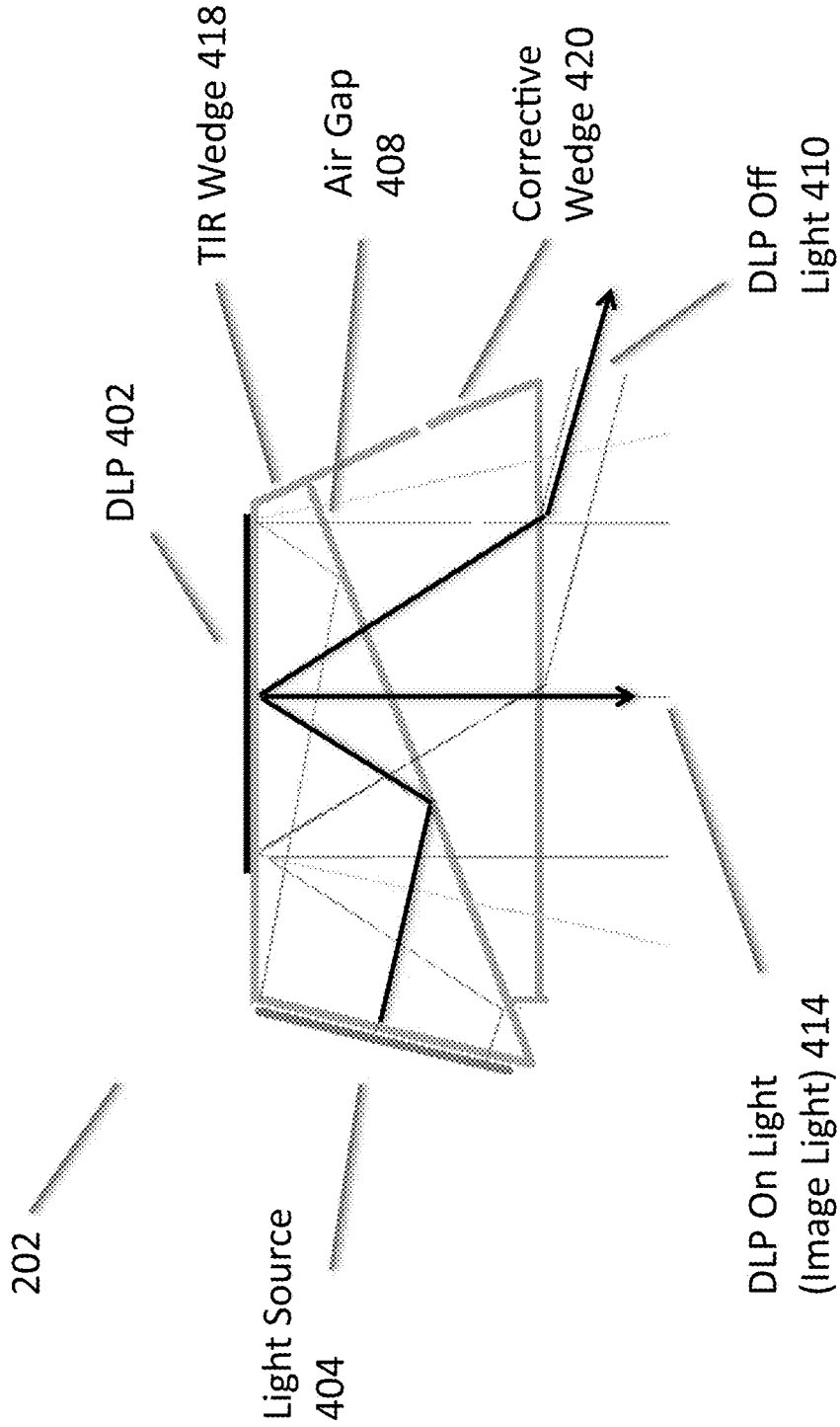

Figure 4

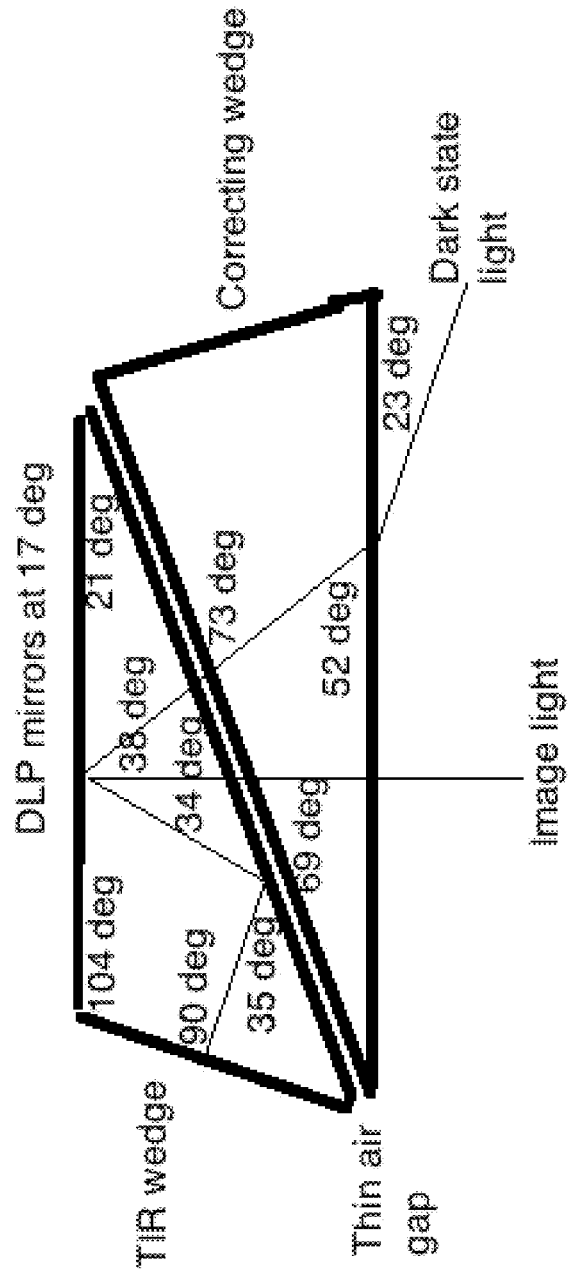

Figure 4a

202

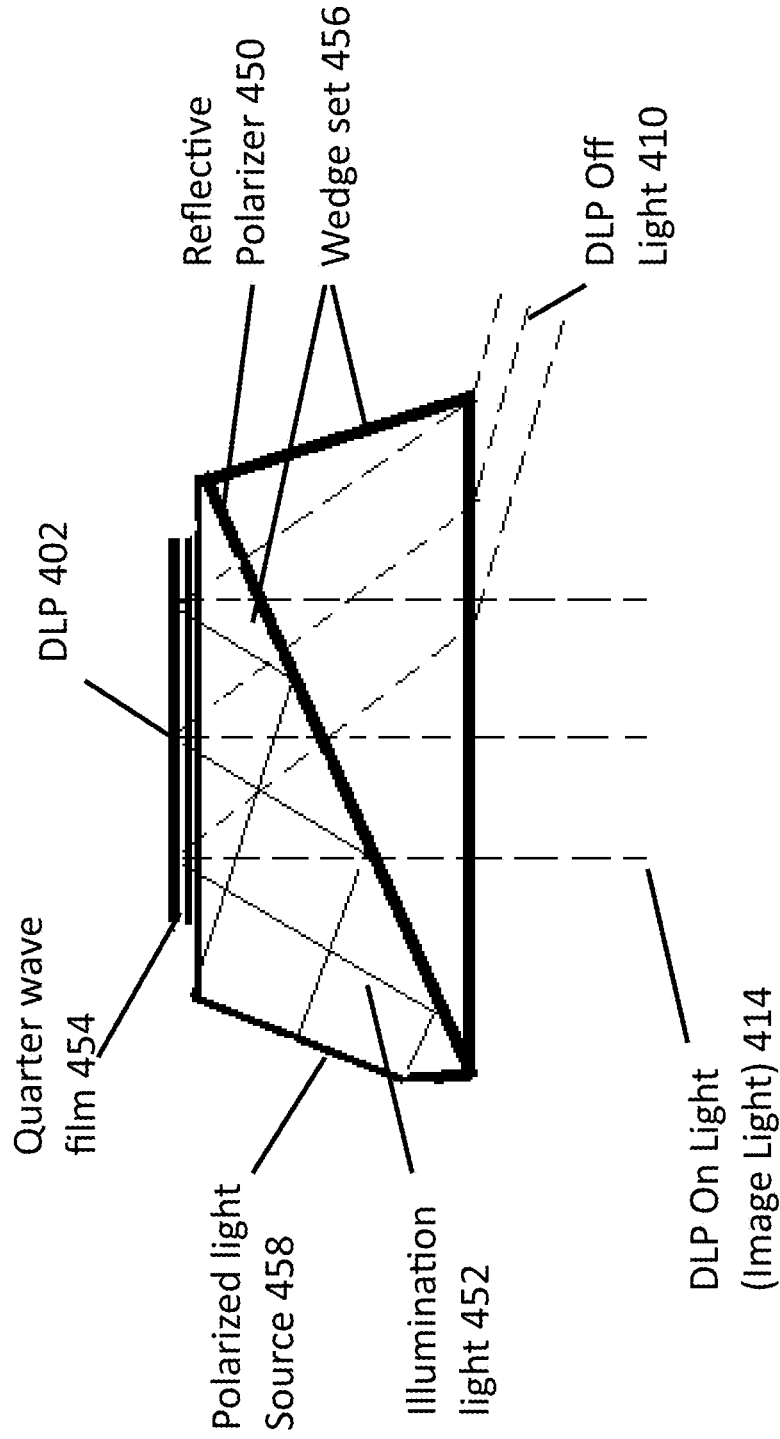

Figure 4b

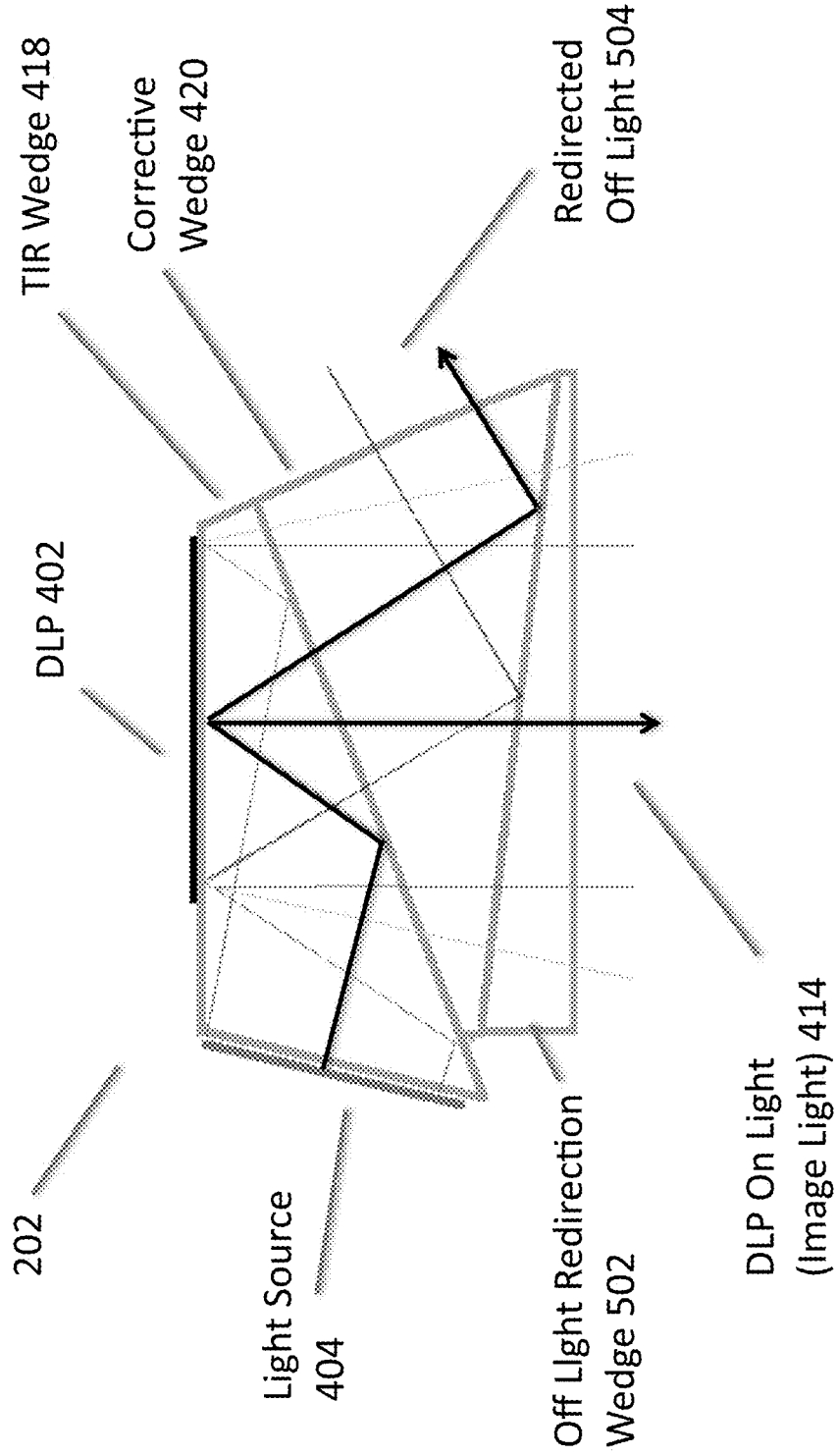

Figure 5

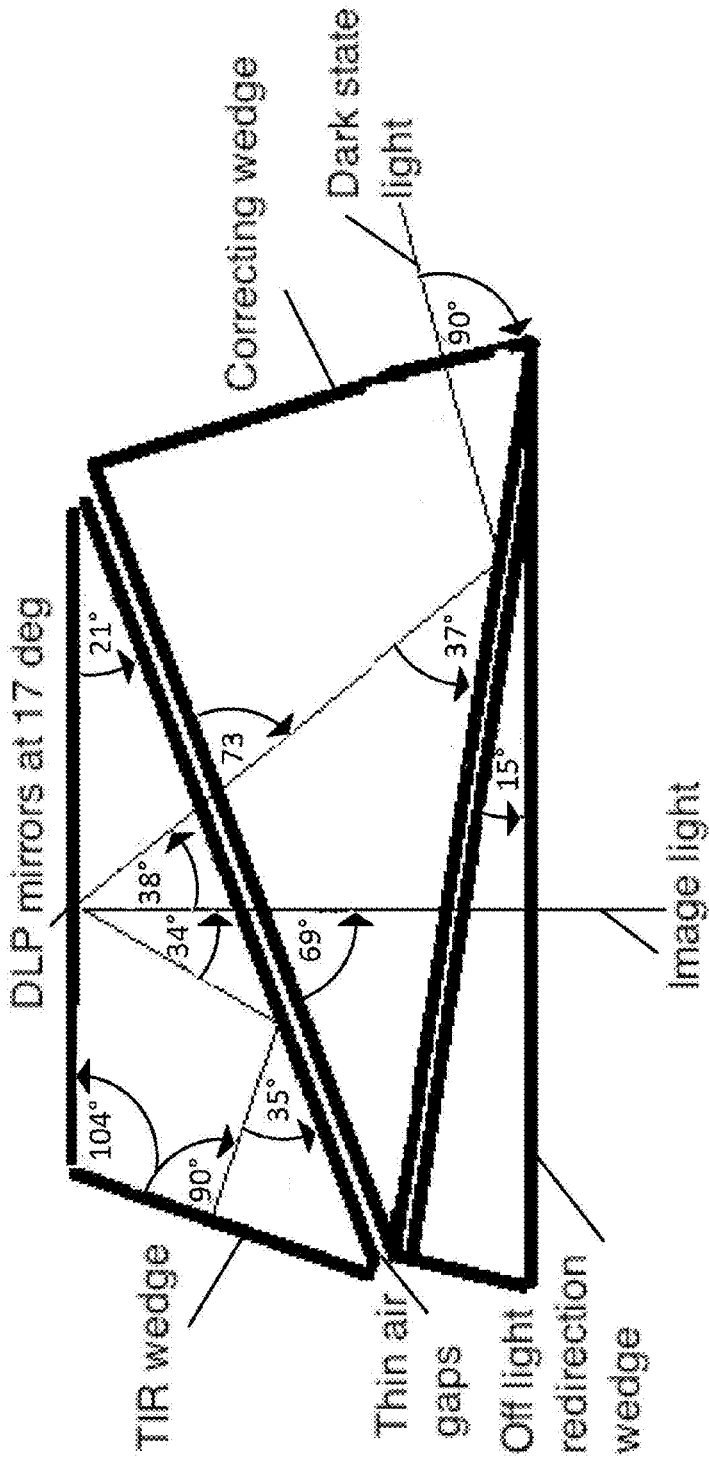

Figure 5a

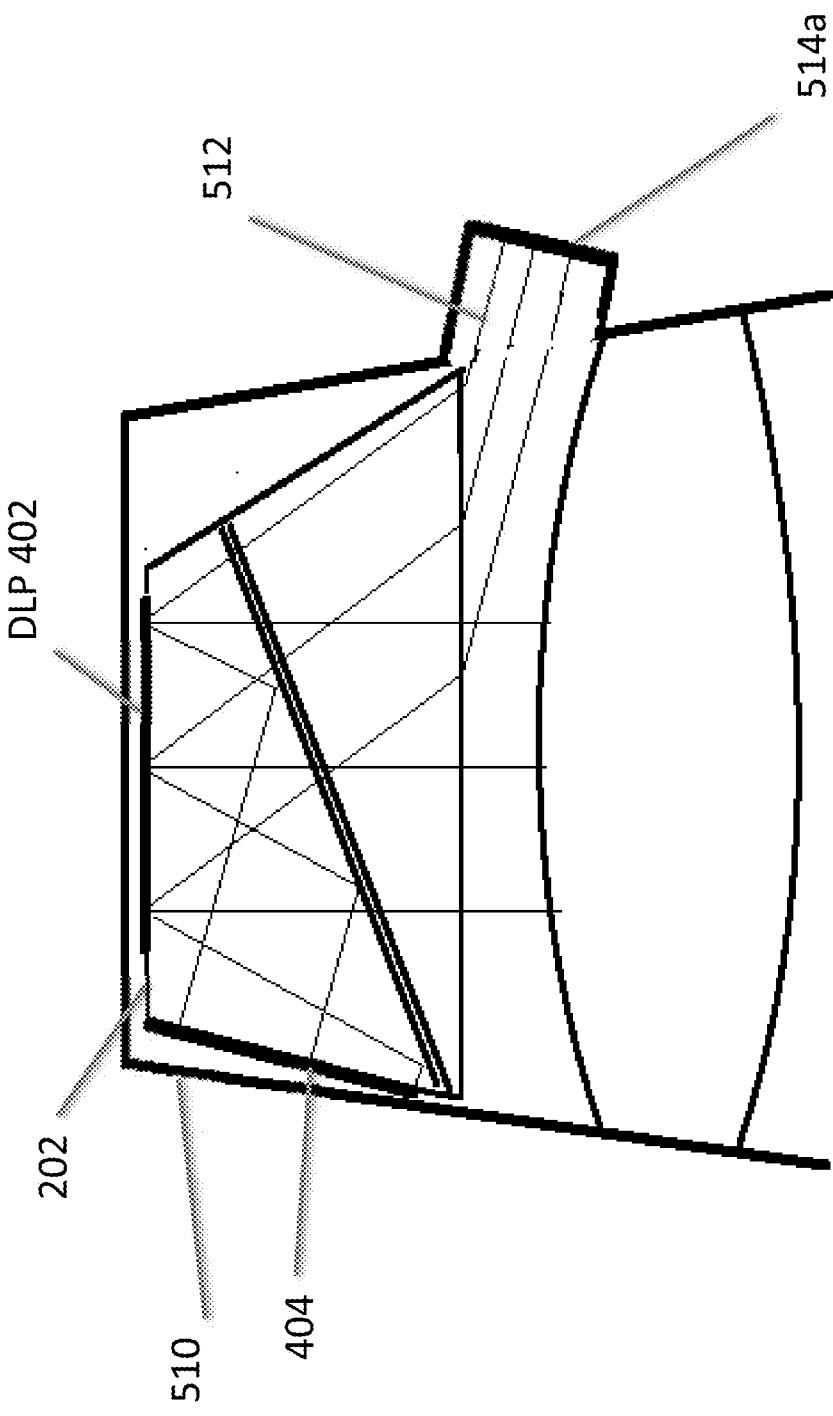

Figure 5b

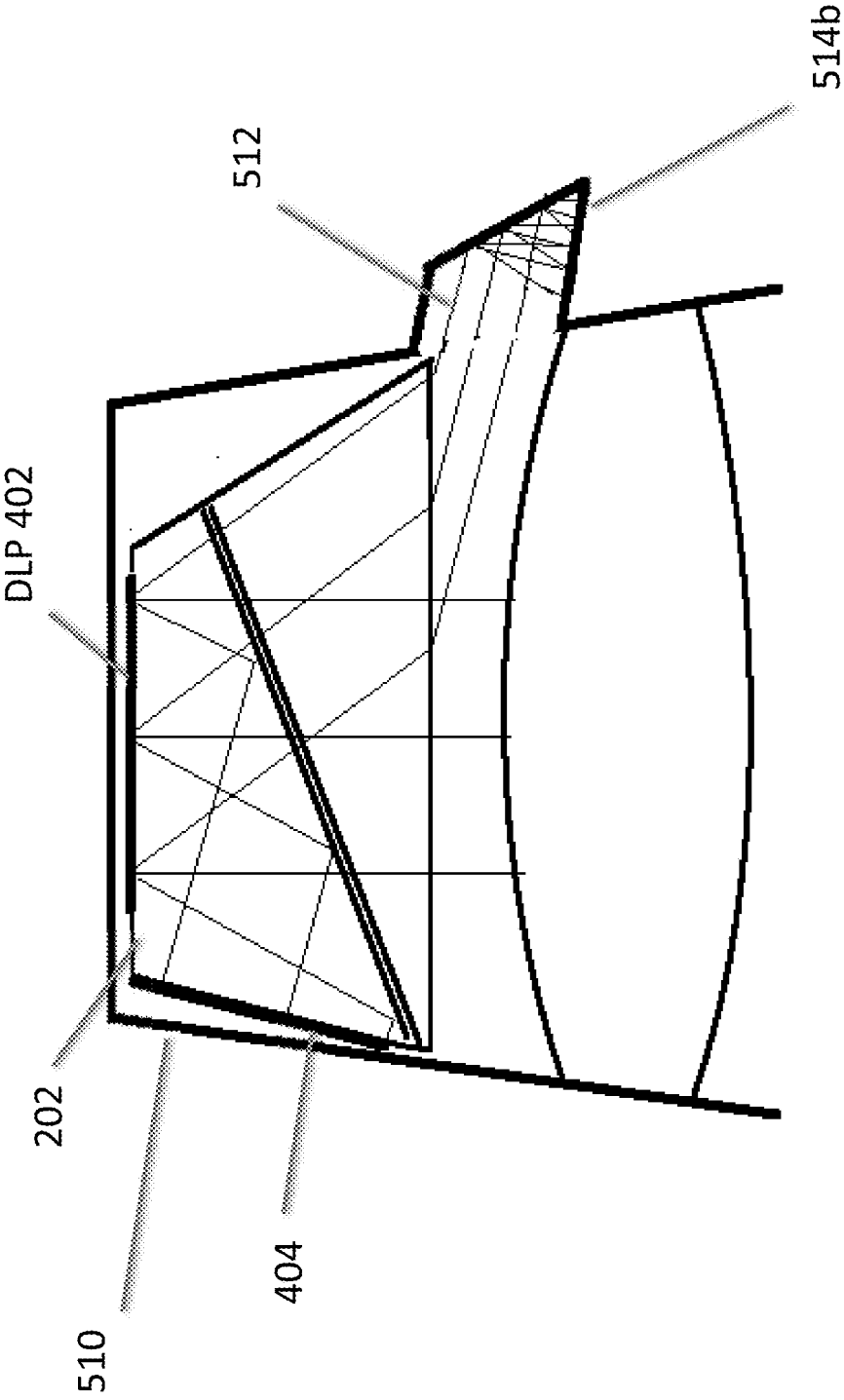

Figure 5c

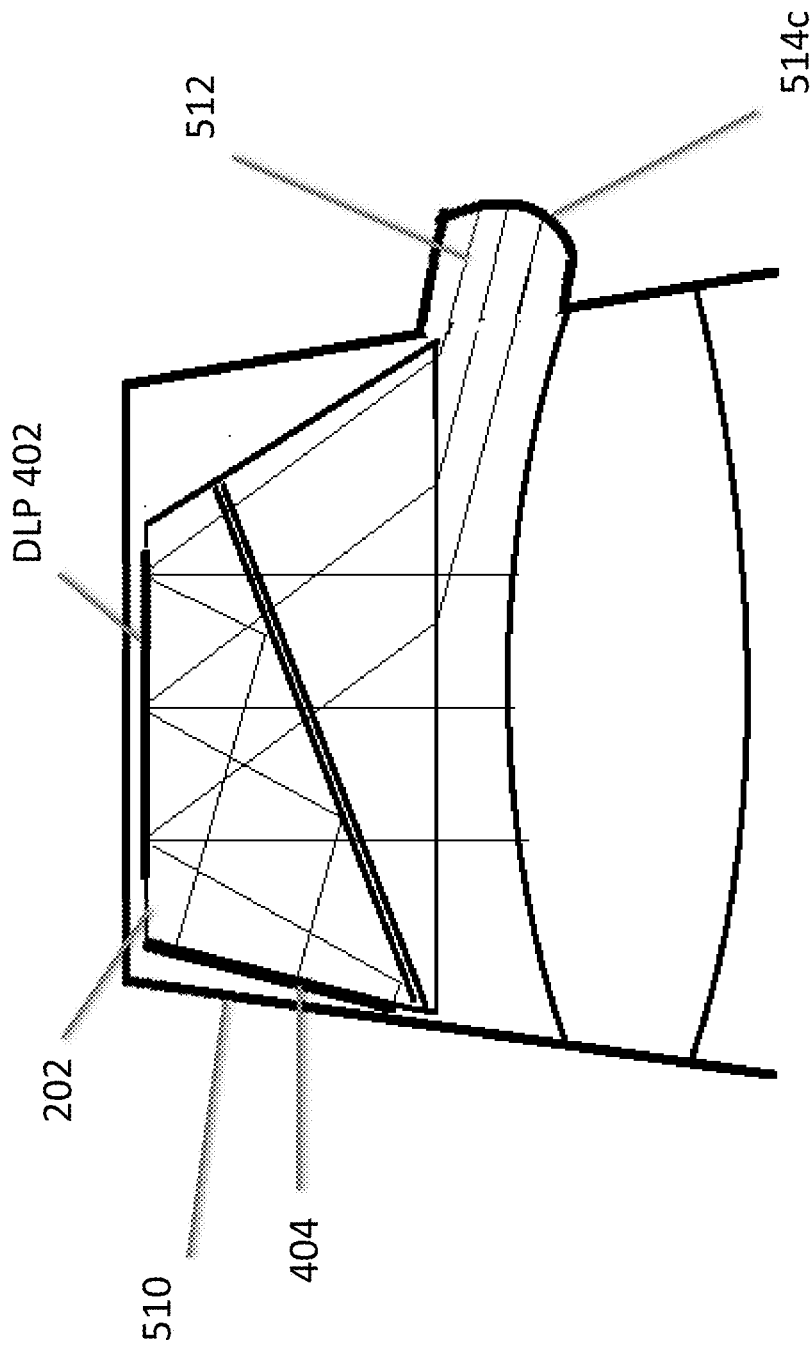

Figure 5d

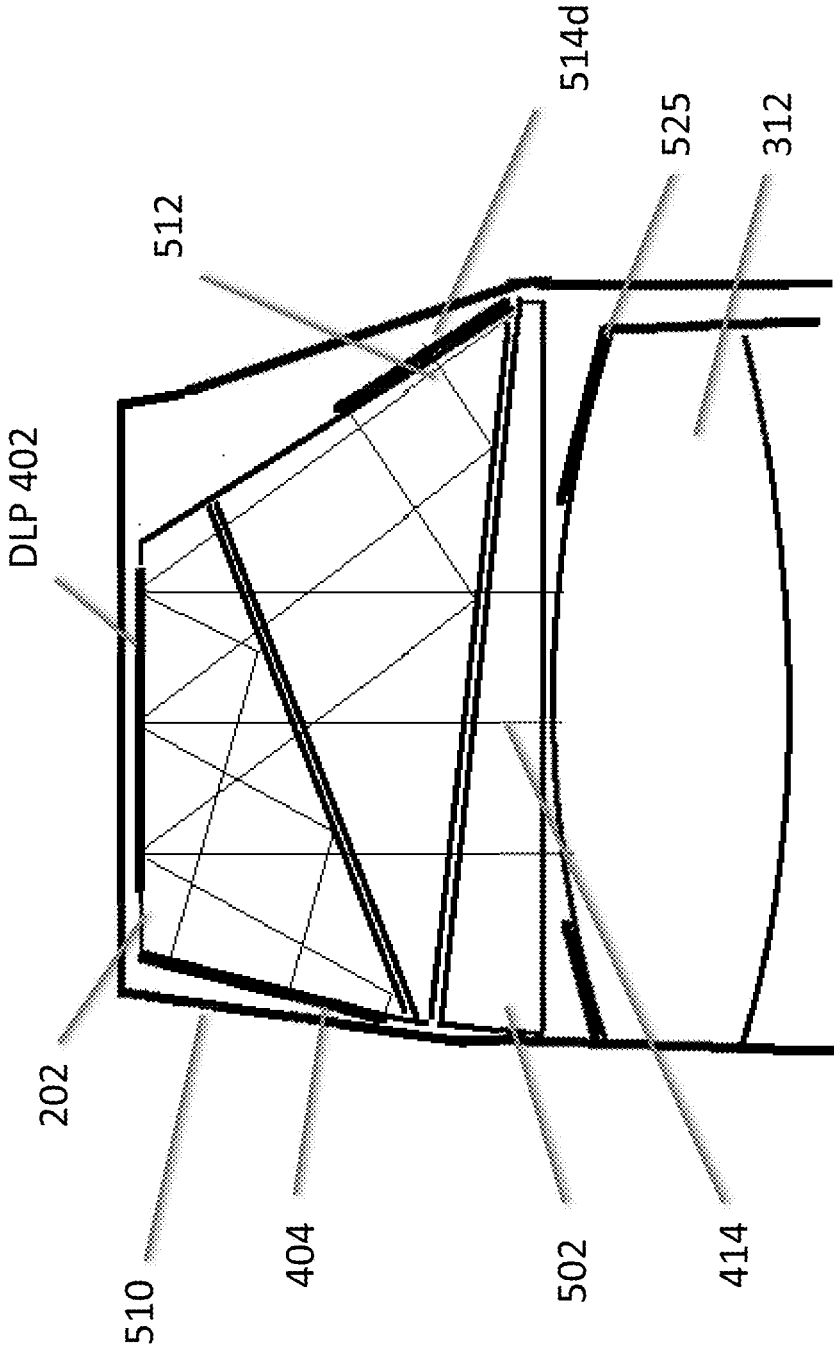

Figure 5e

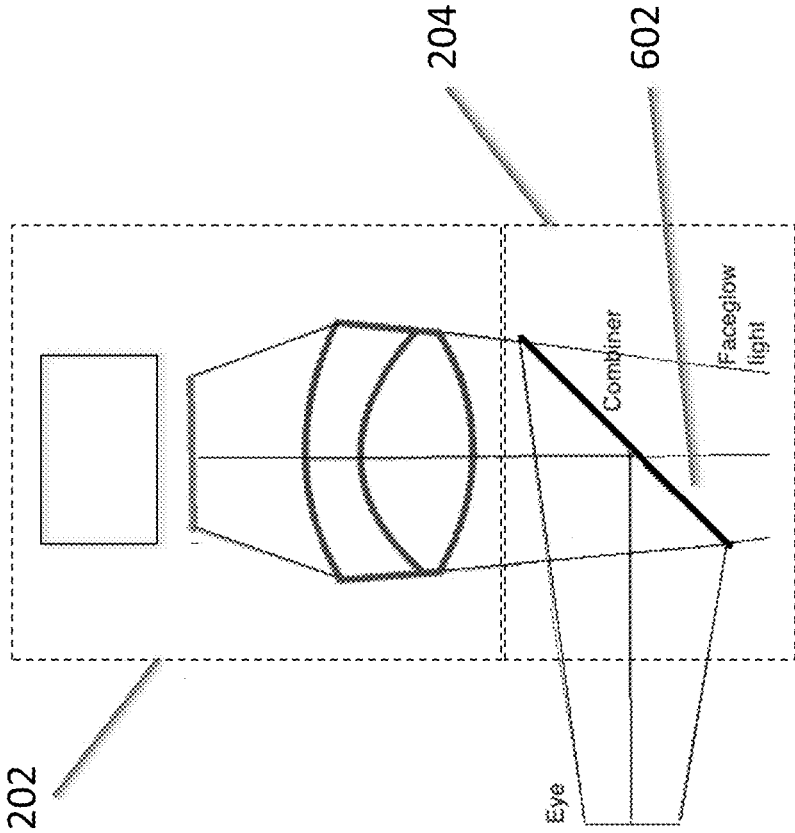

Figure 6

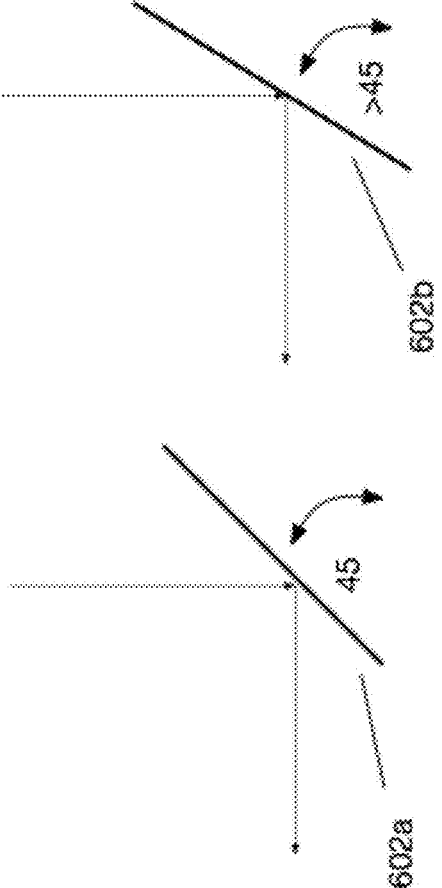

Figure 7

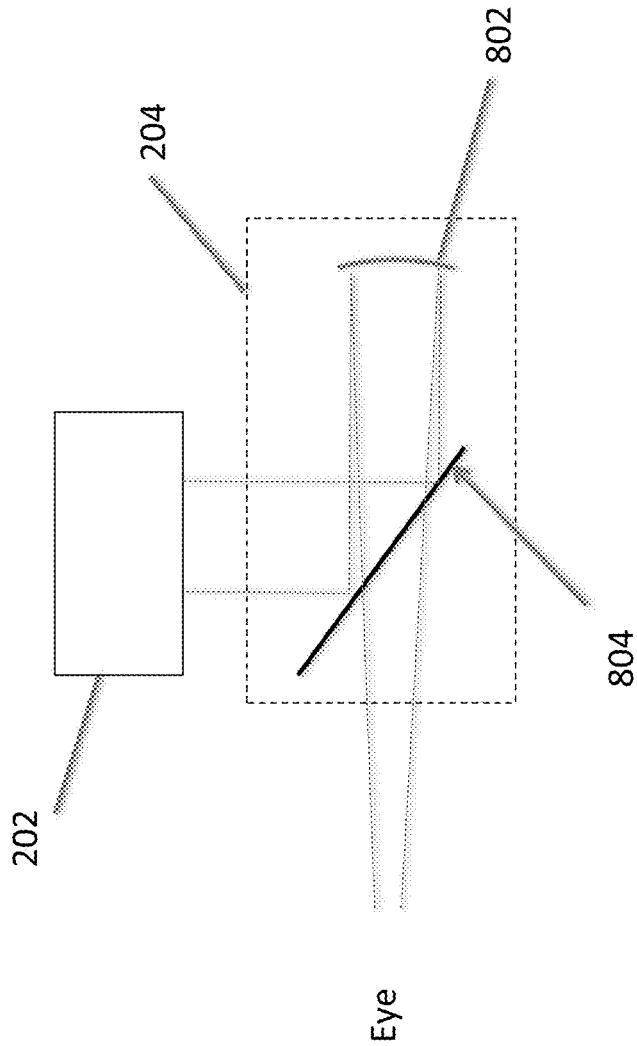

Figure 8

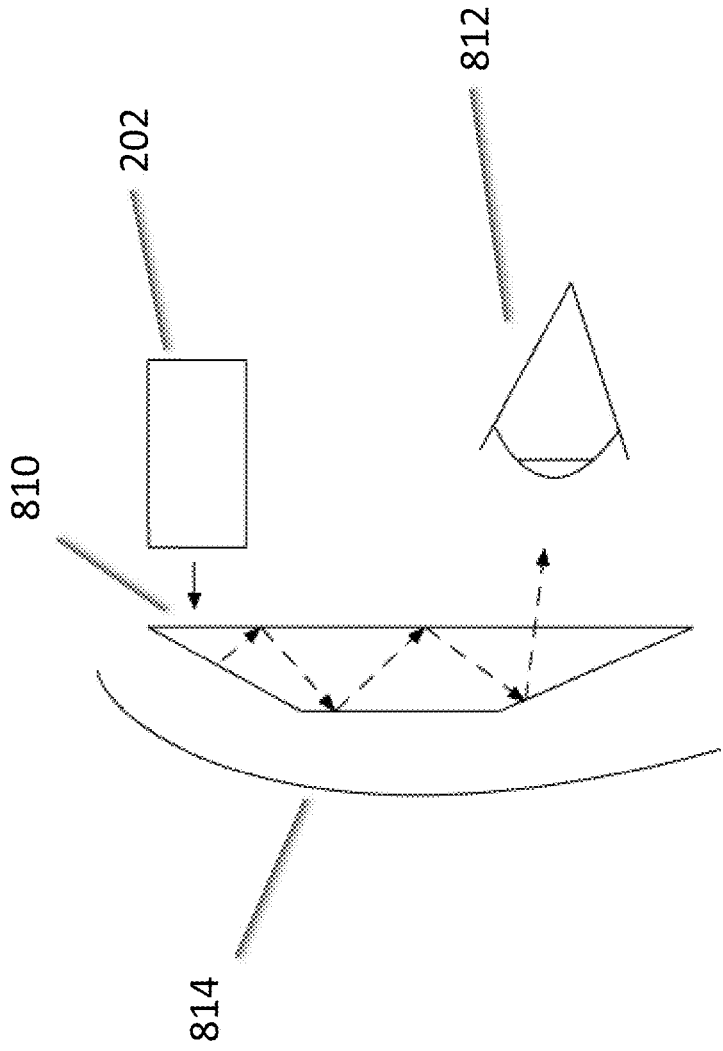

Figure 8a

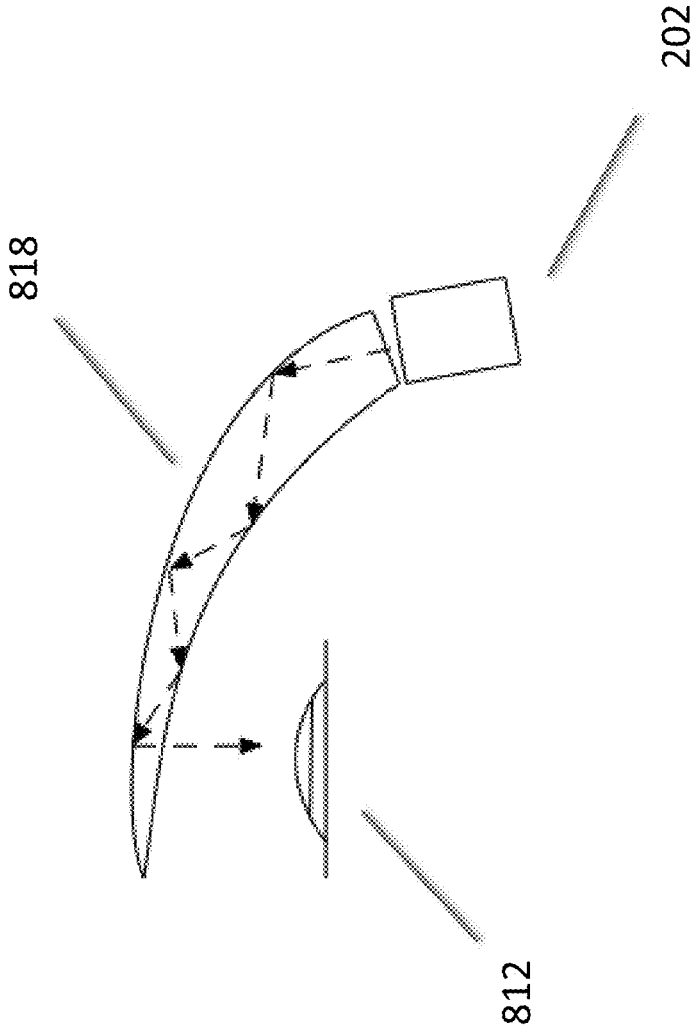

Figure 8b

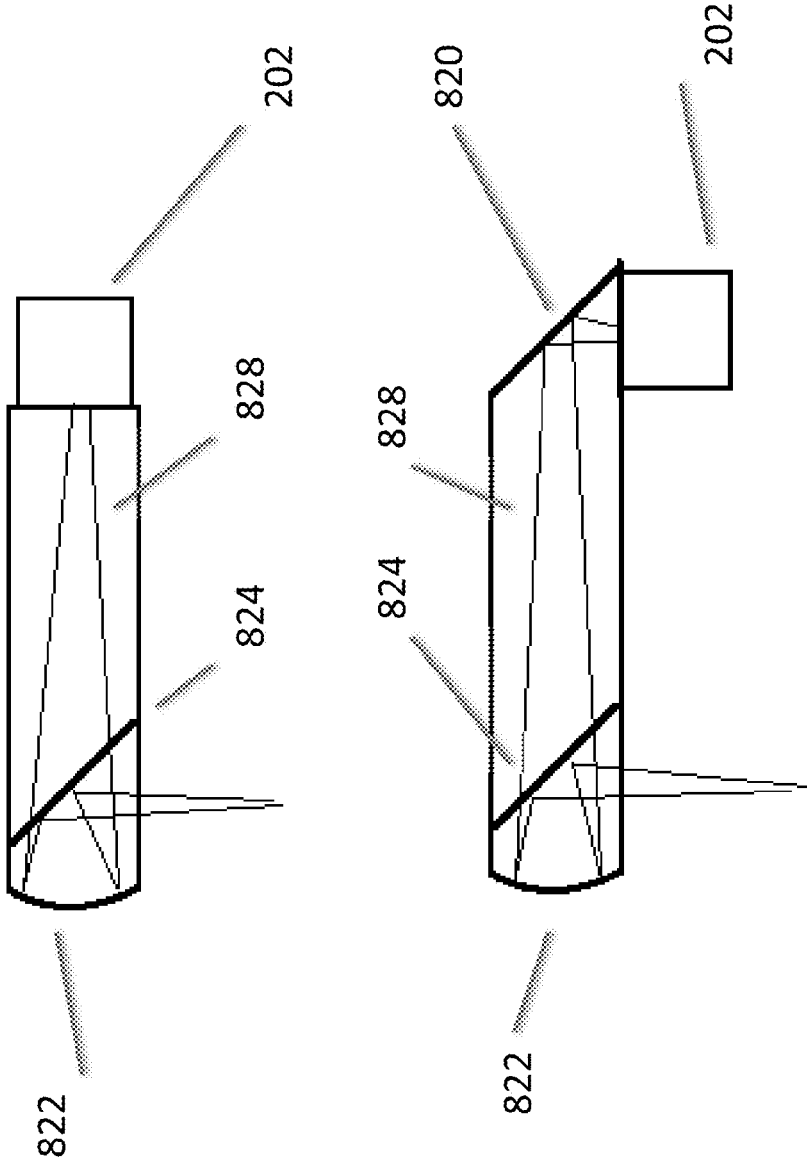

Figure 8c

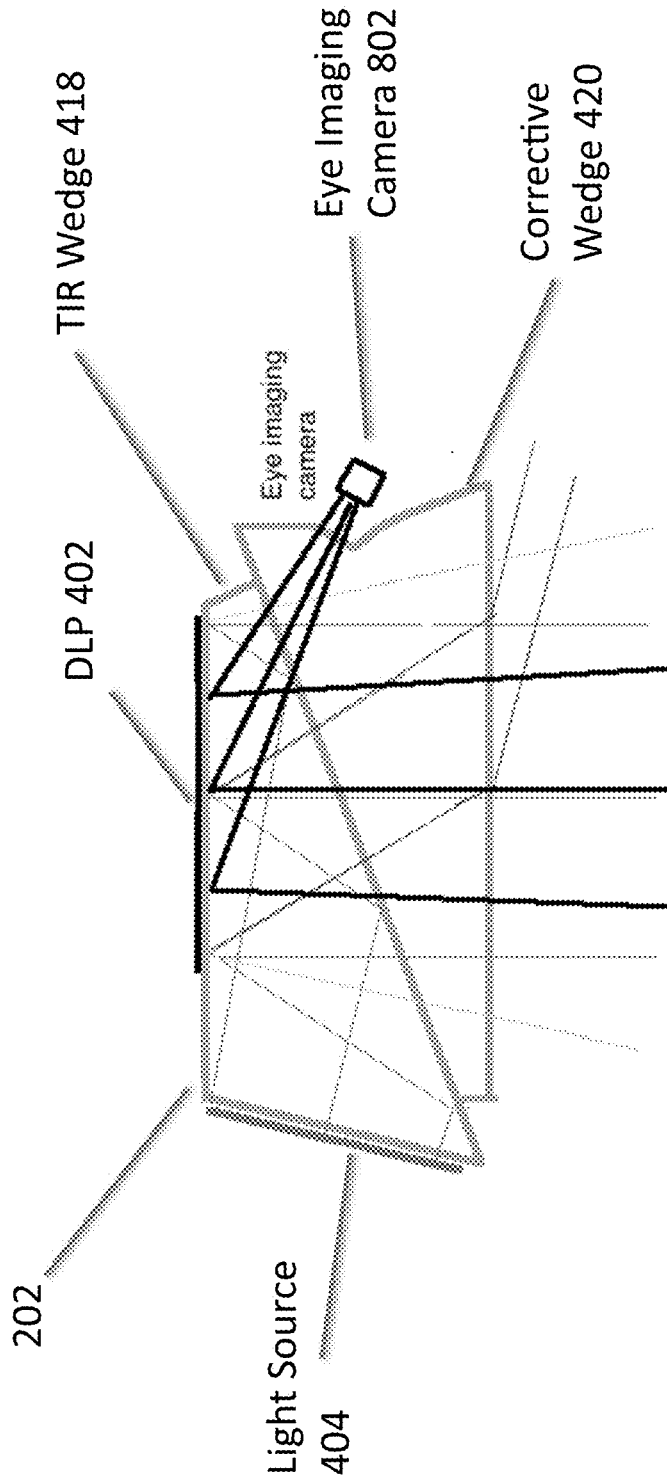

Figure 9

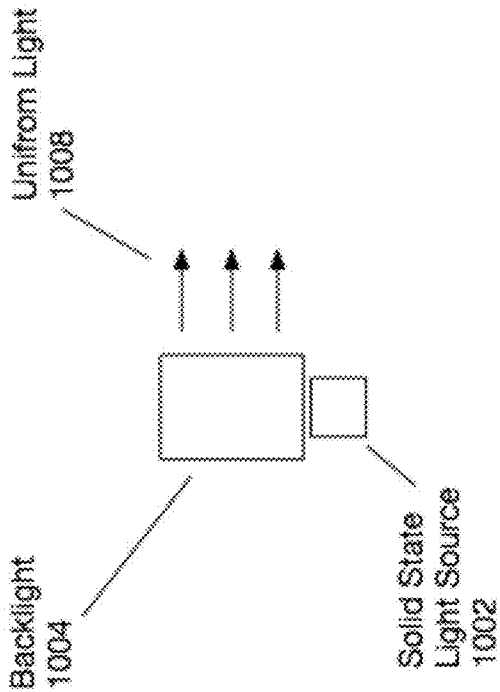

Figure 10

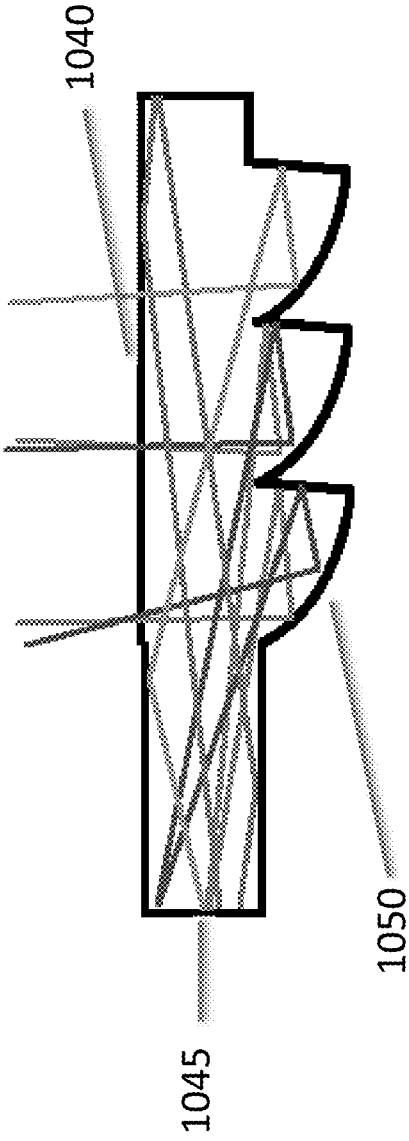

Figure 10a

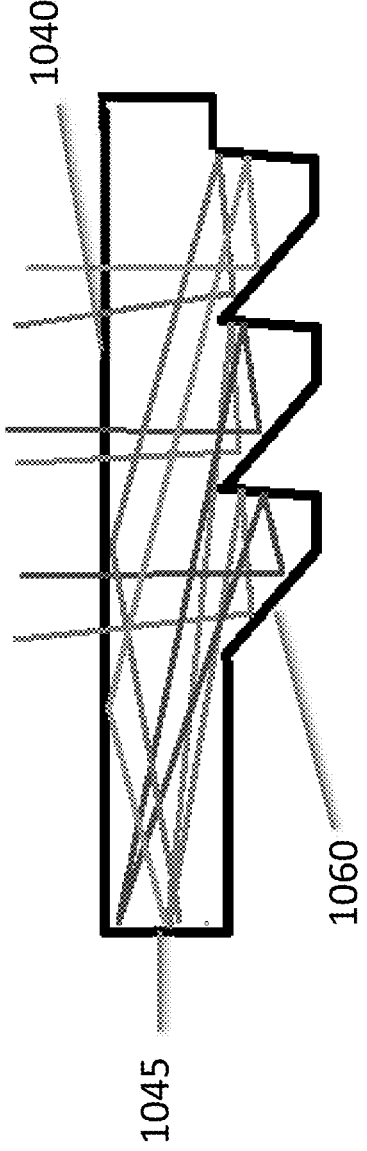

Figure 10b

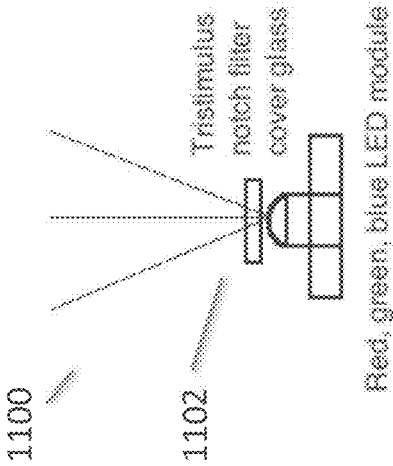

Figure 11a

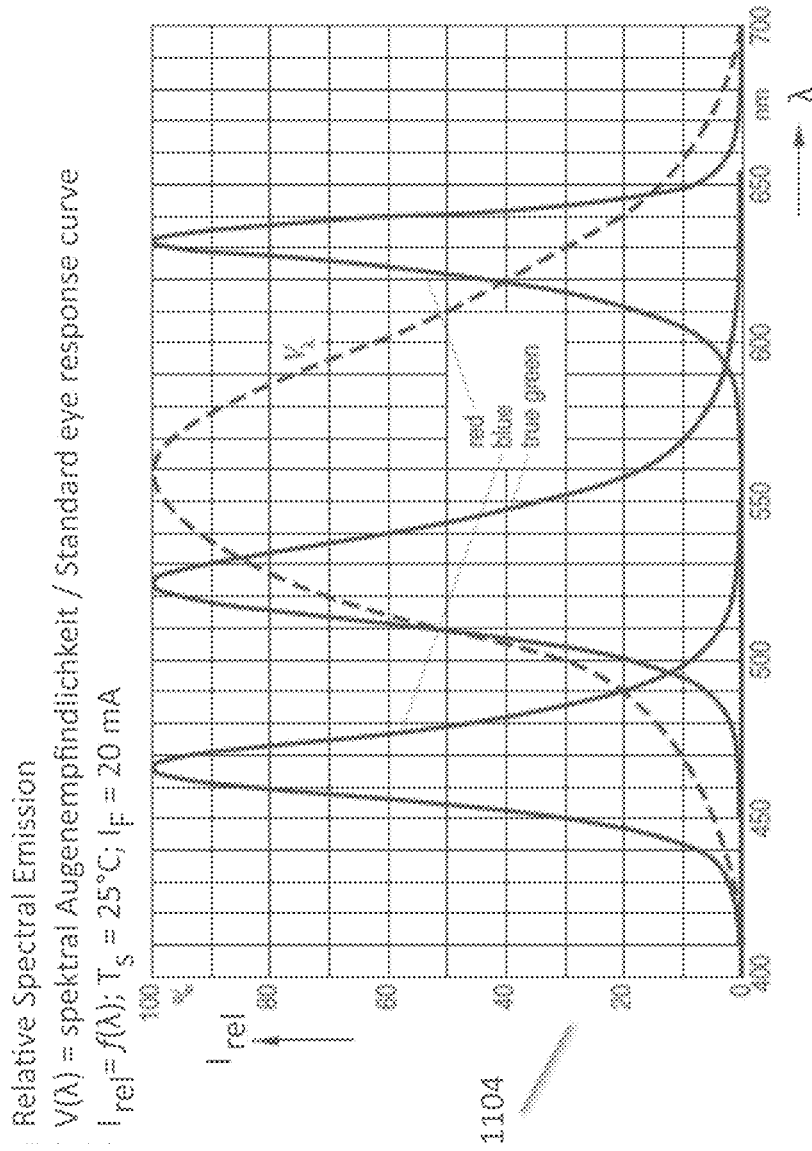

Fig. 11b

1108 →

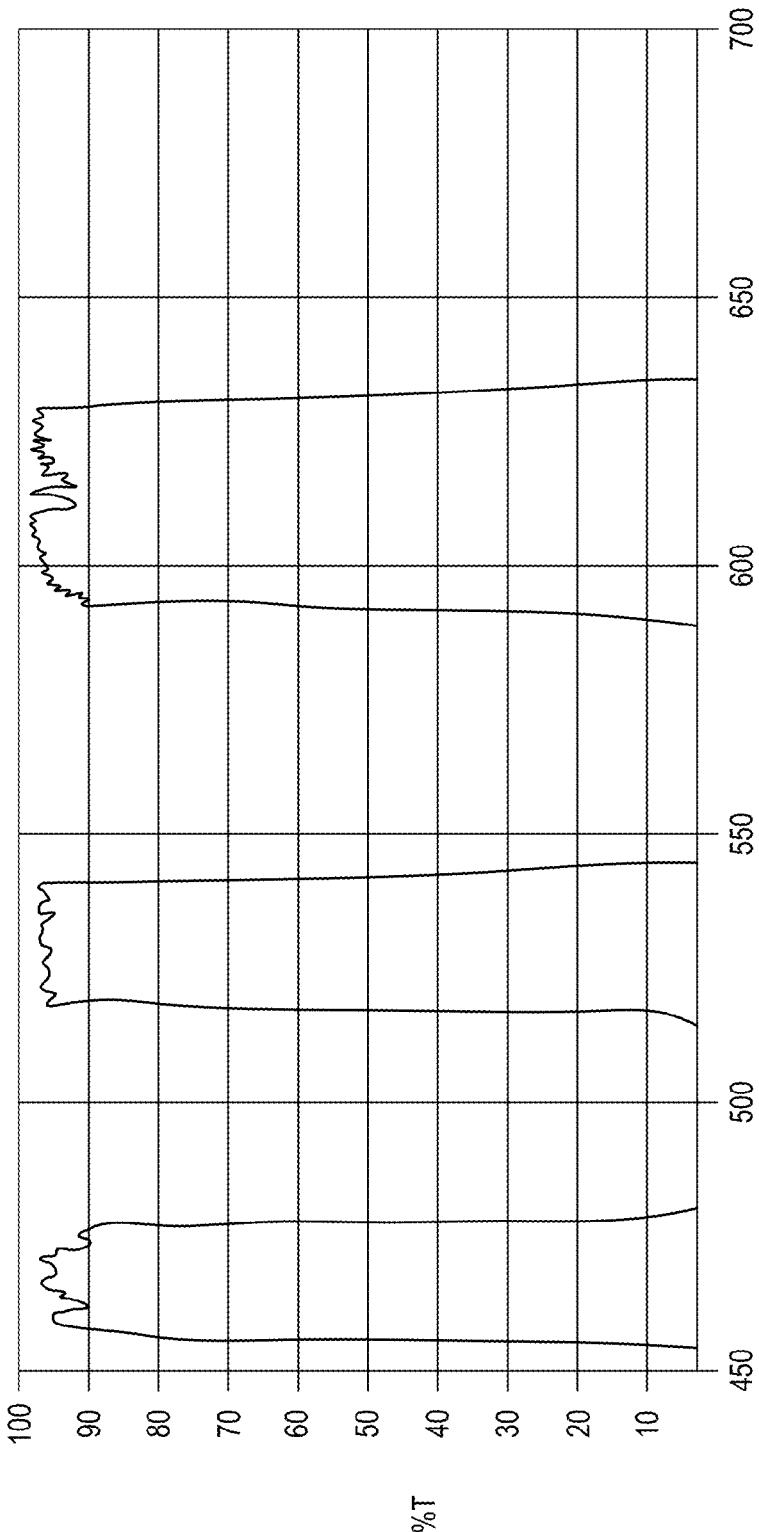

FIG. 11C

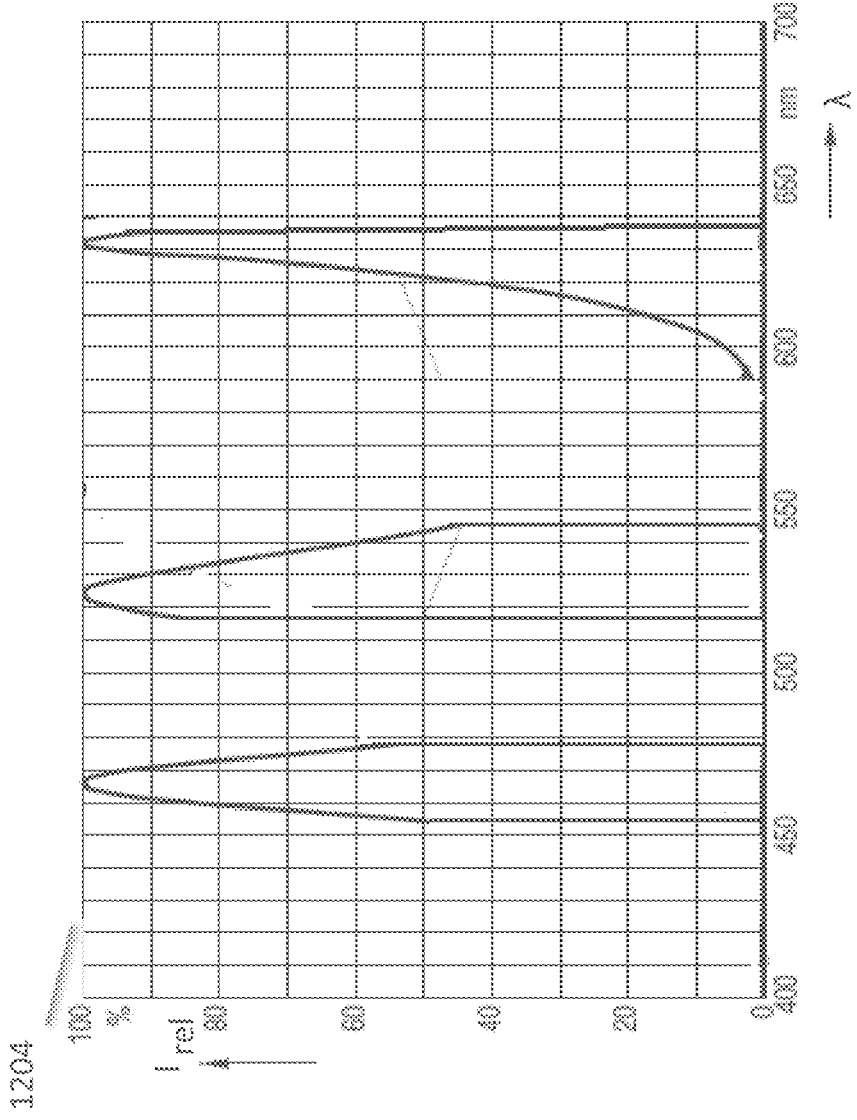

Fig. 11d

1204

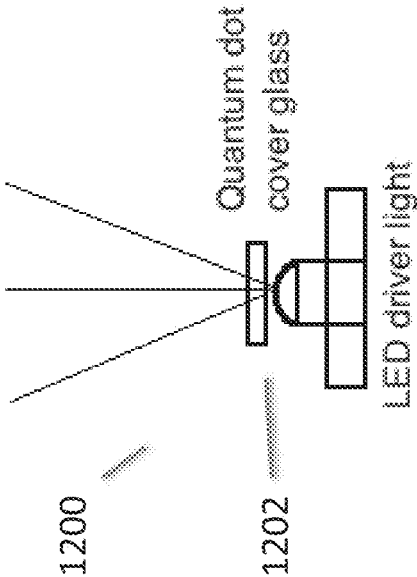

Figure 12a

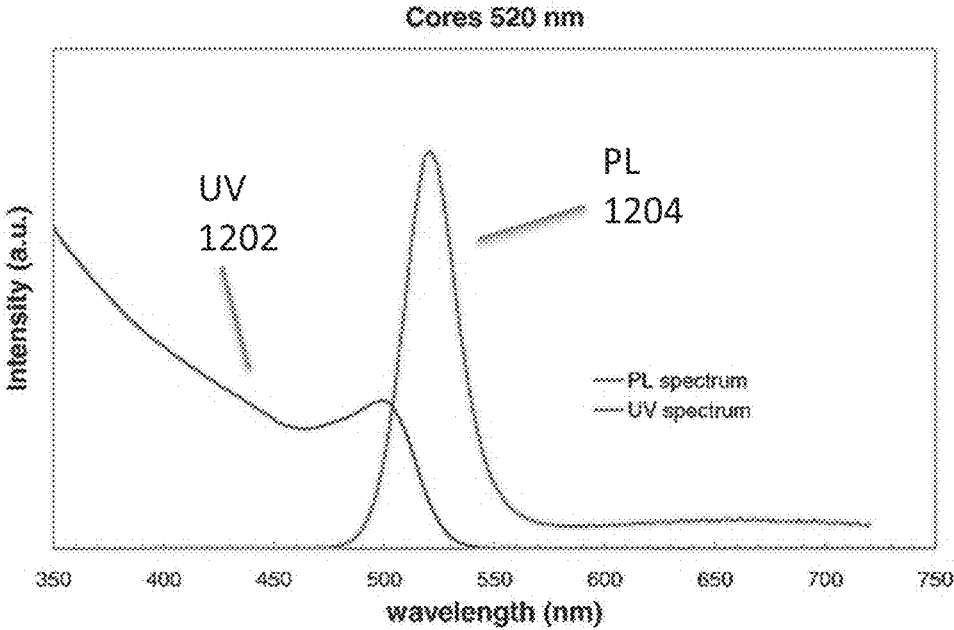

Figure 12b

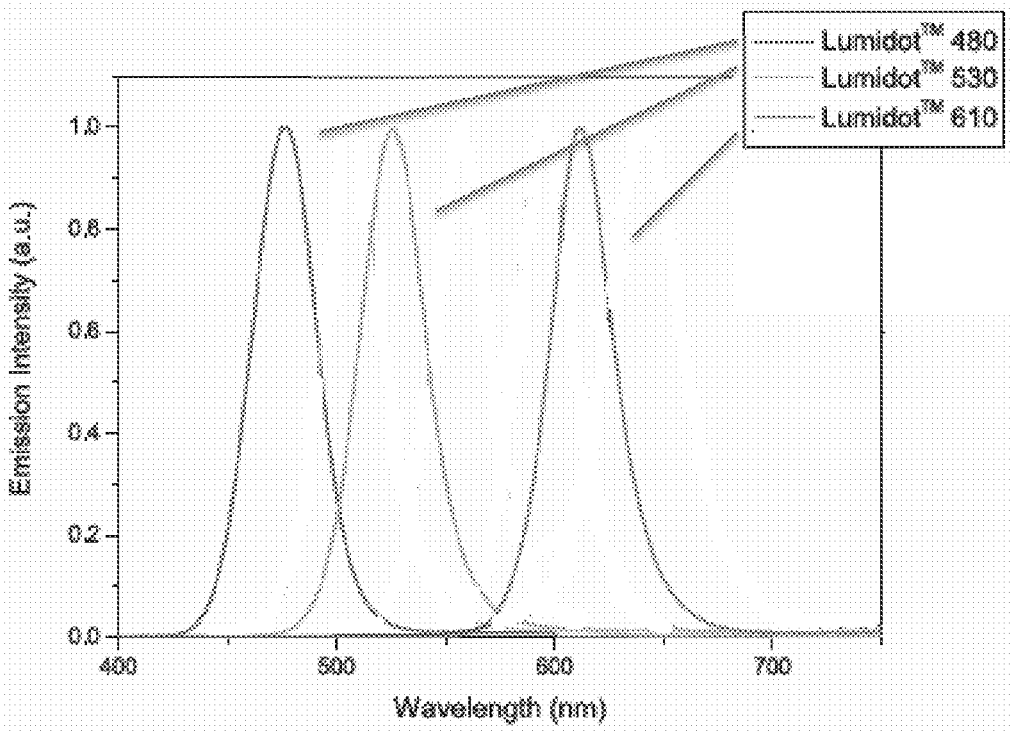

Figure 12c

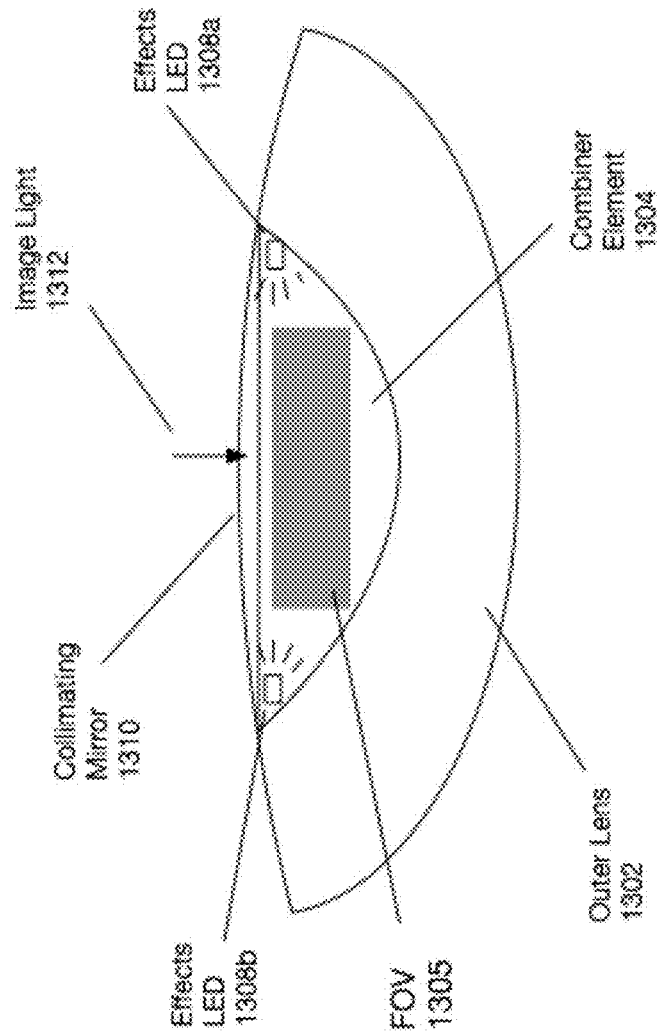

Figure 13a

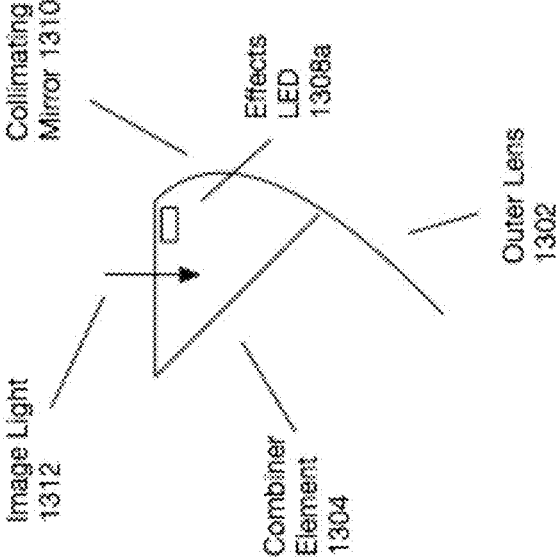

Figure 13b

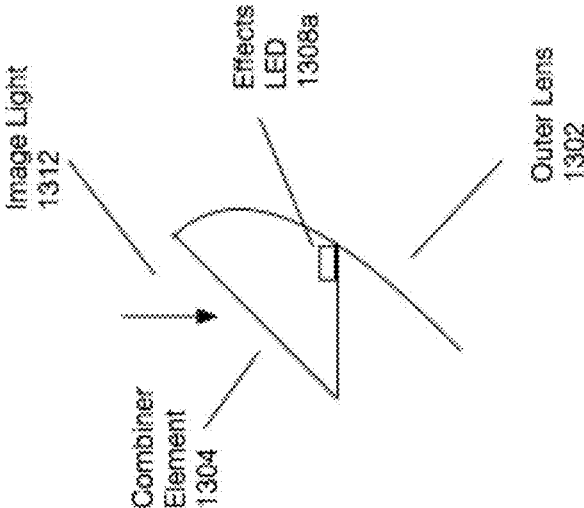

Figure 13c

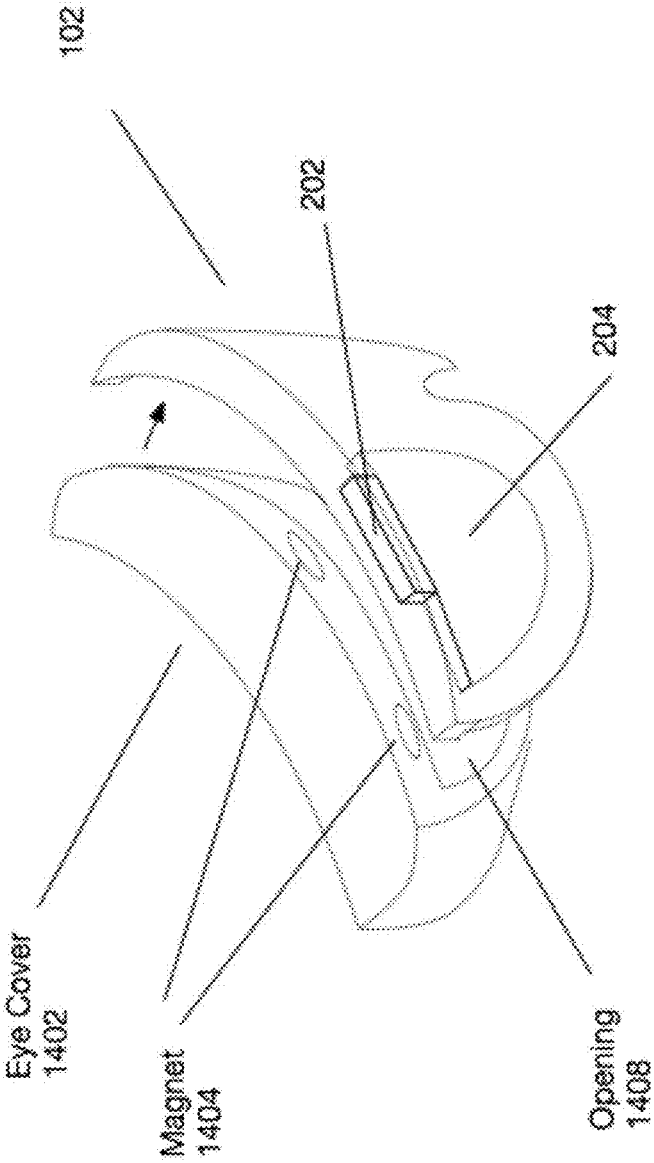

Figure 14a

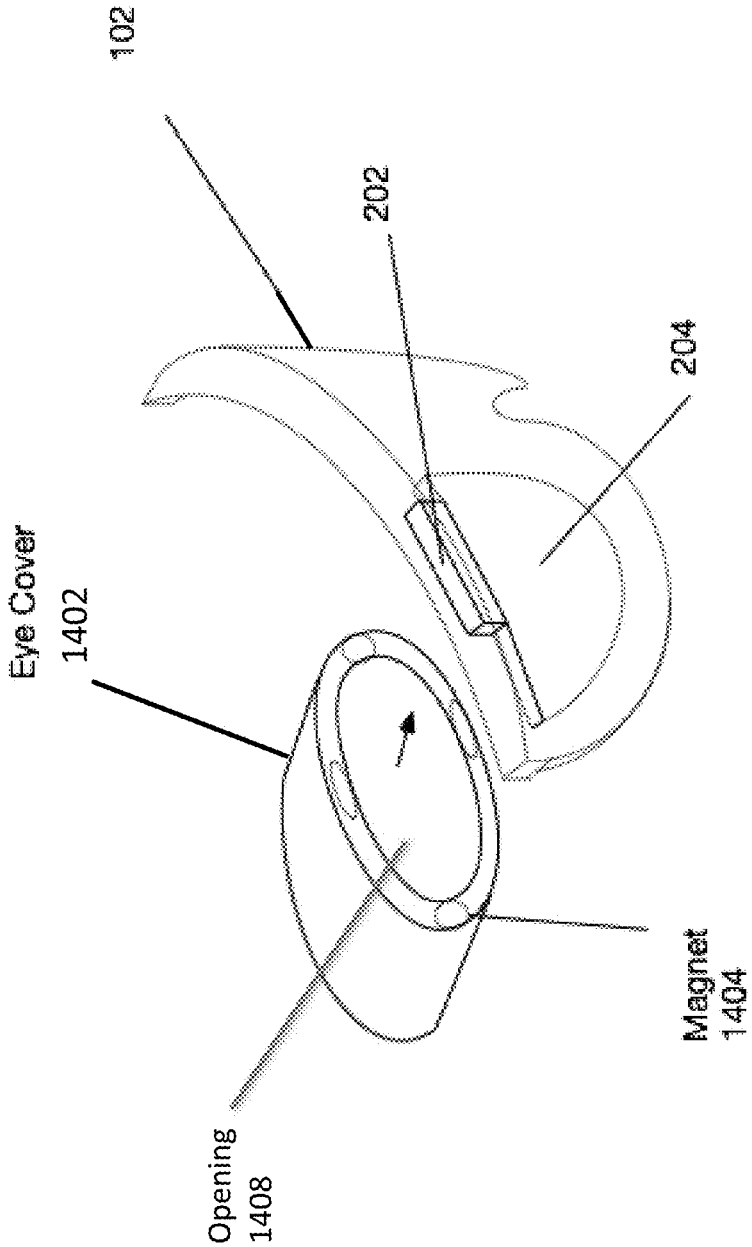

Figure 14b

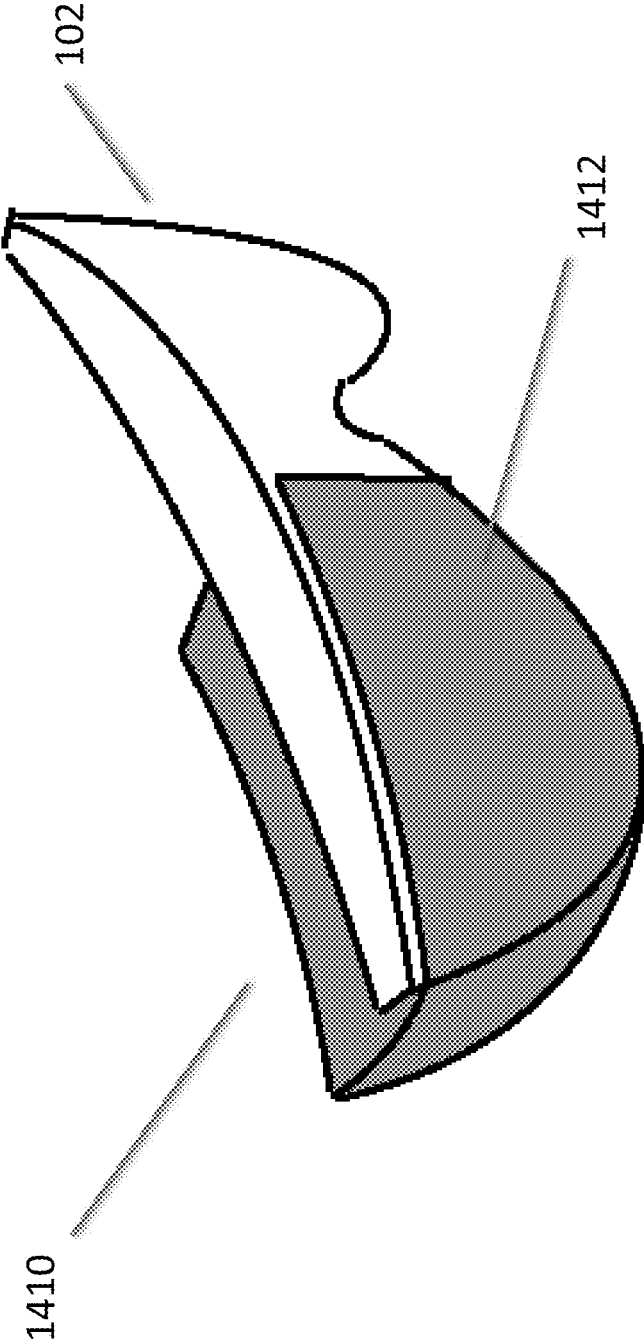

Figure 14c

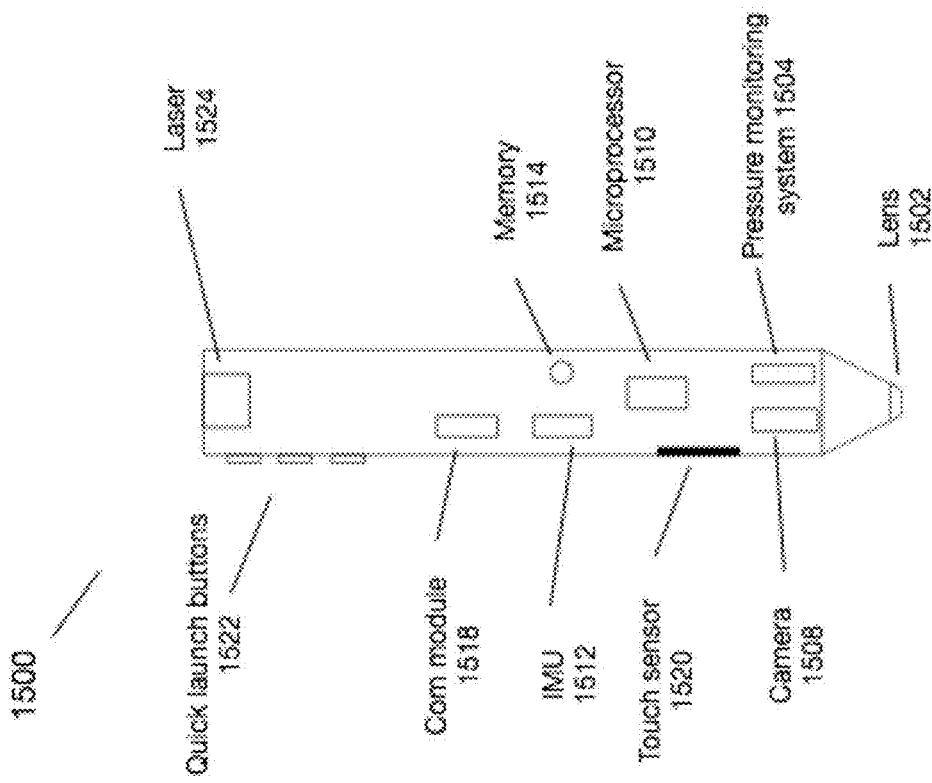

Figure 15

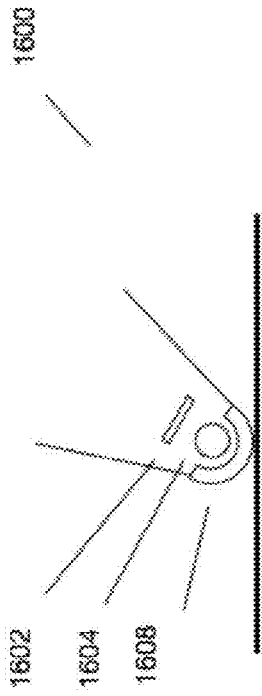

Fig. 16A

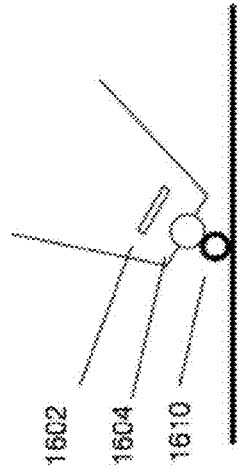

Fig. 16B

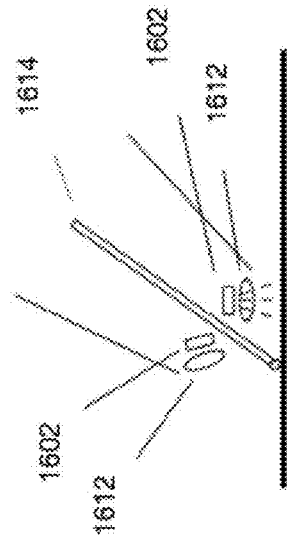
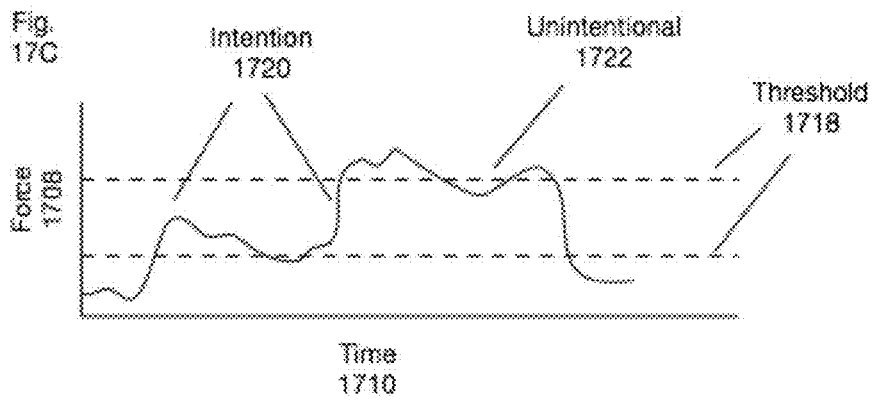
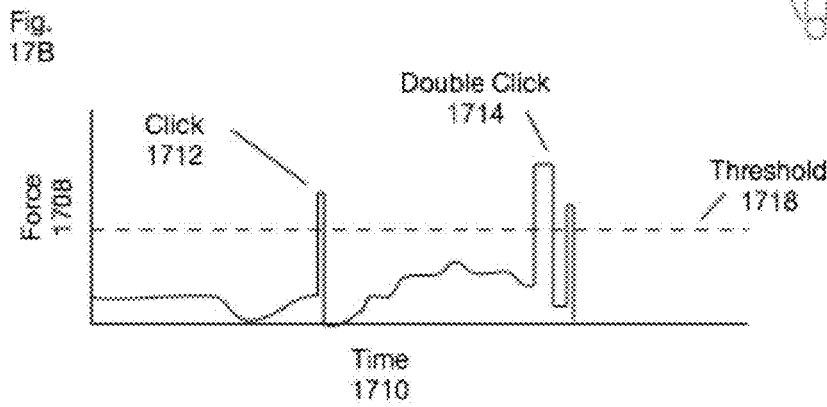
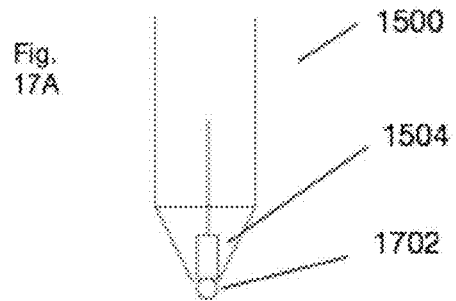
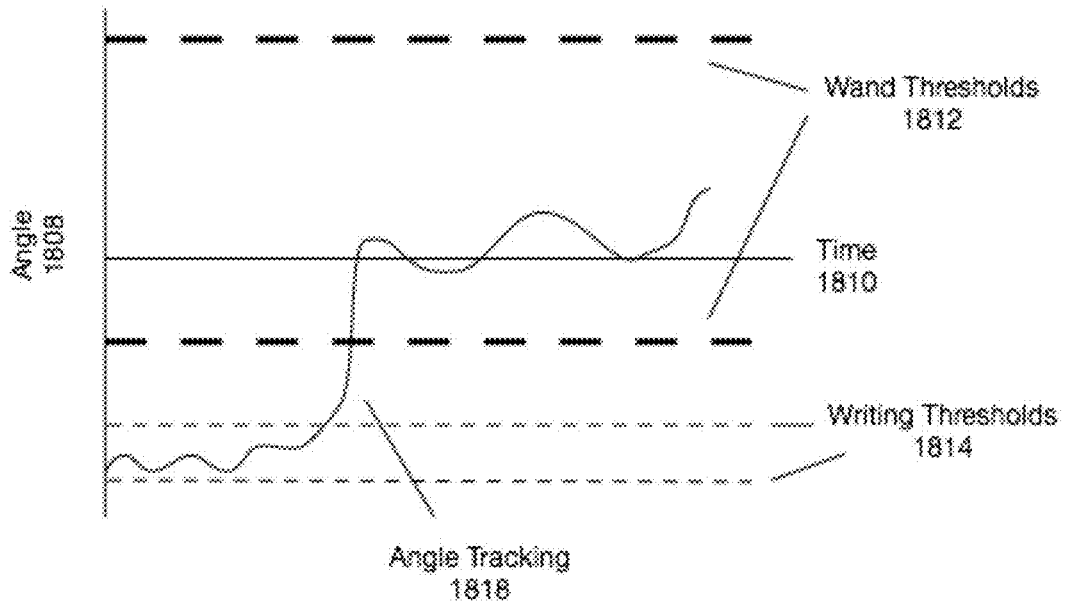
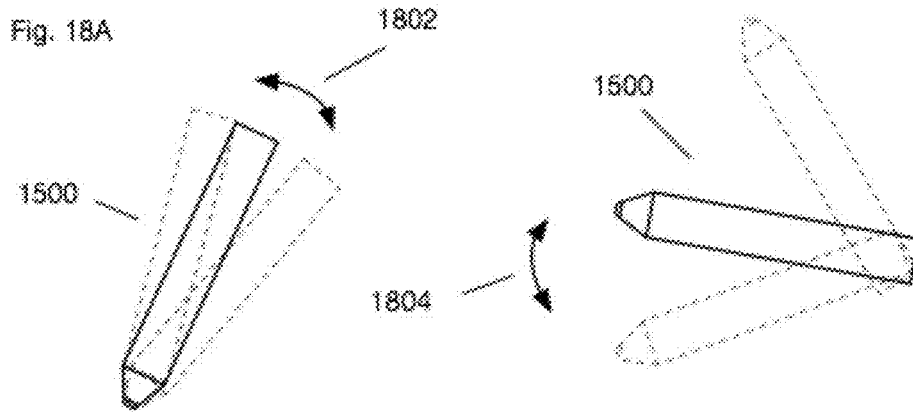

Fig. 16C





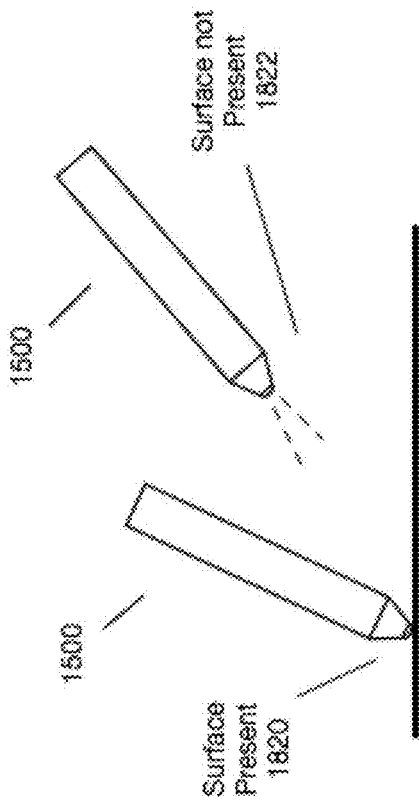

Fig. 18B

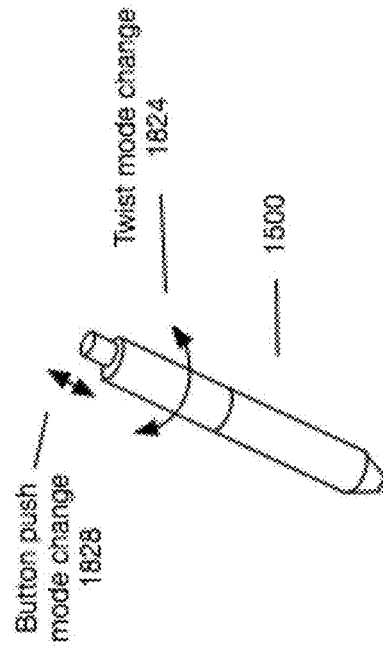
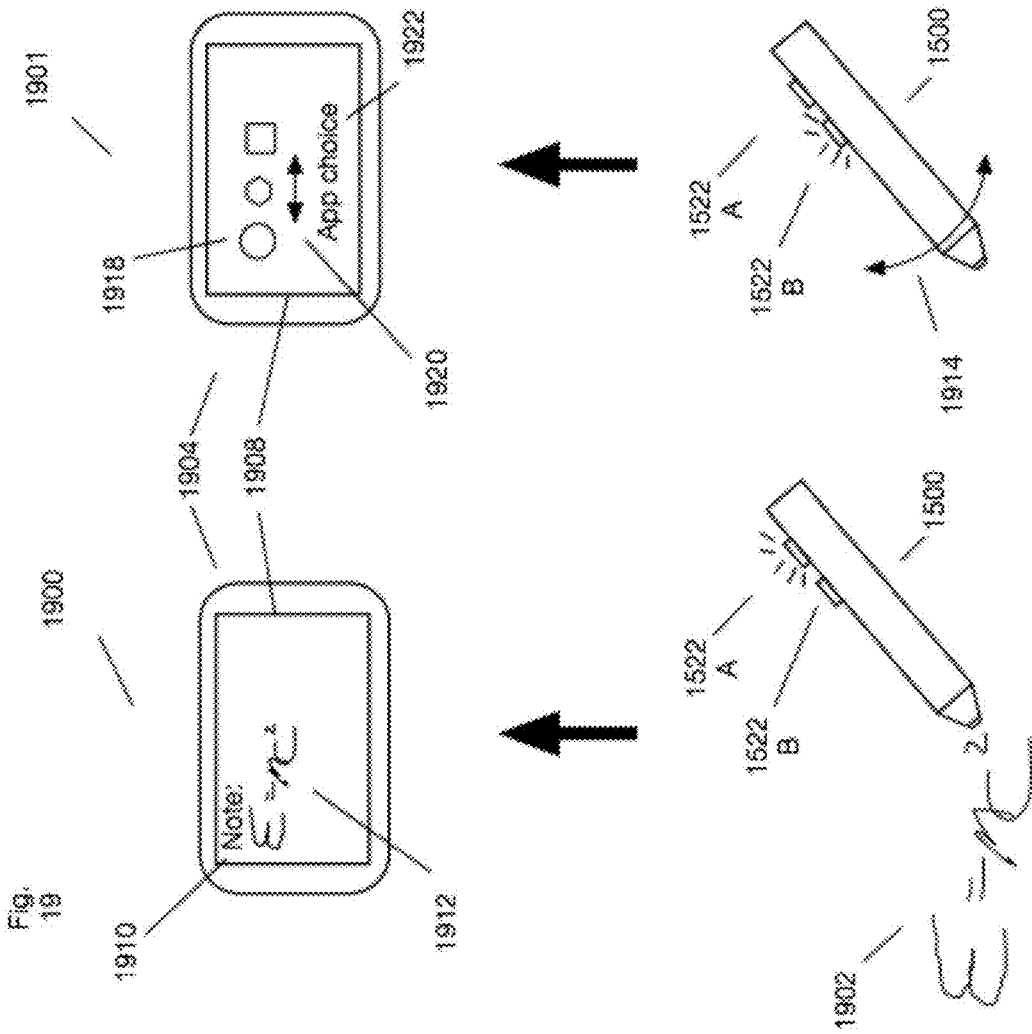

Fig. 18C



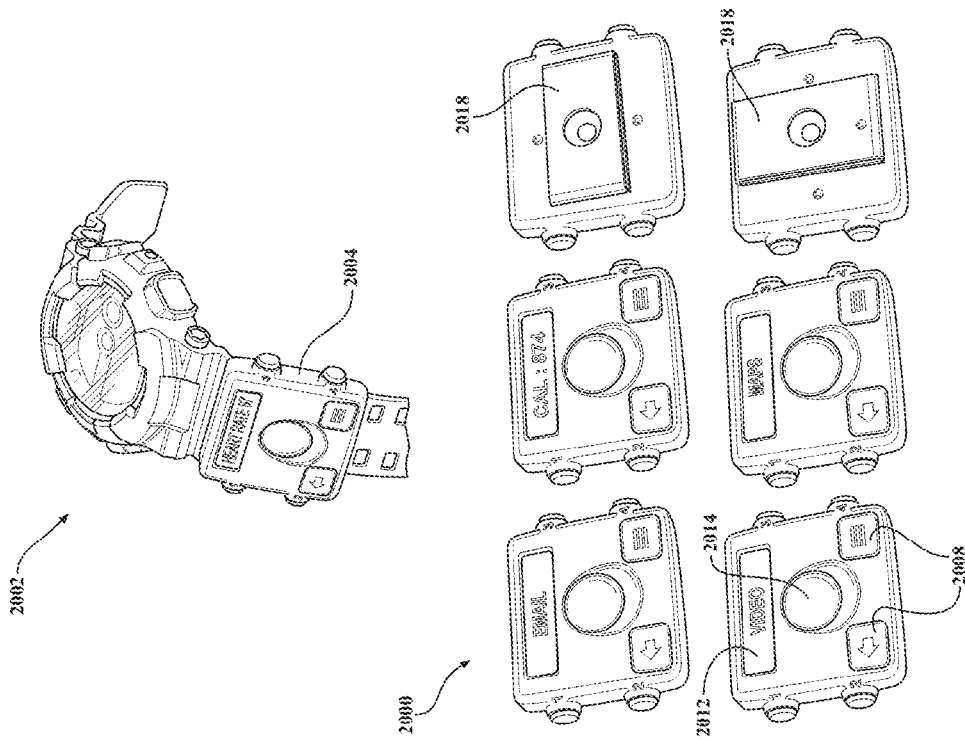

FIG. 20

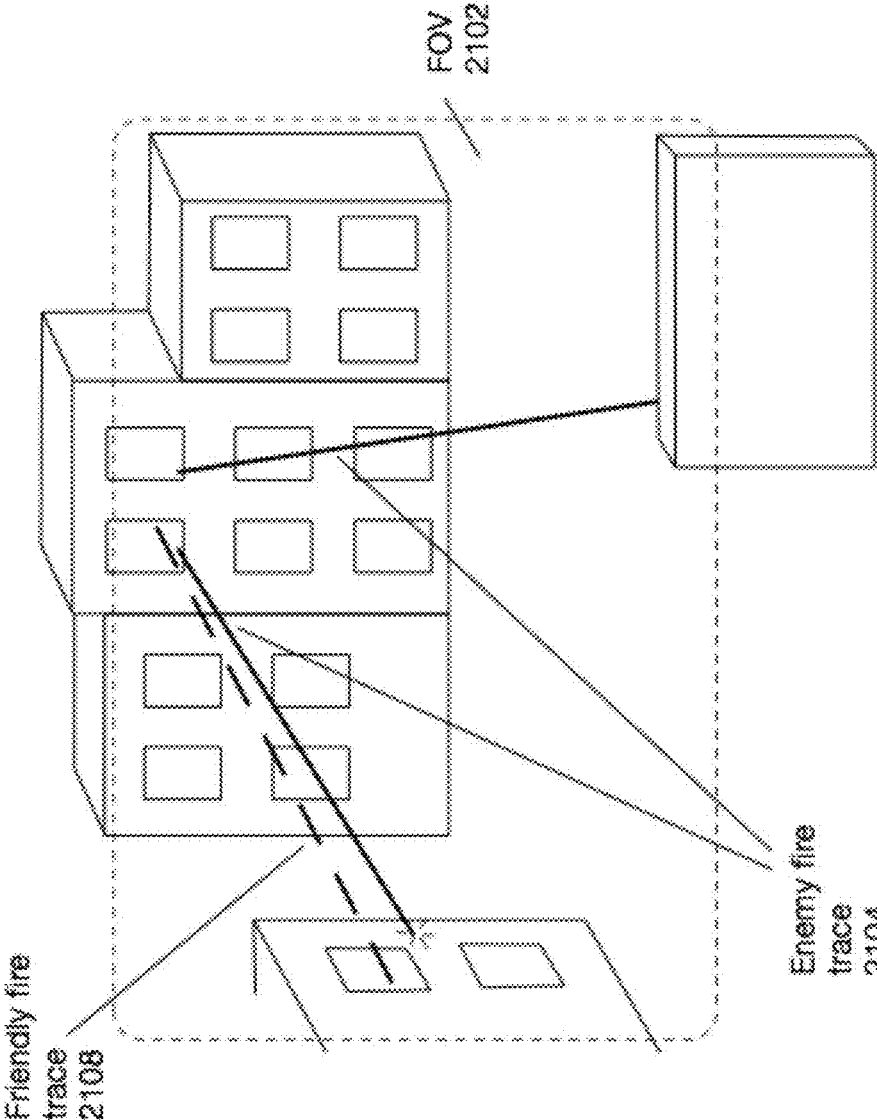

Figure 21

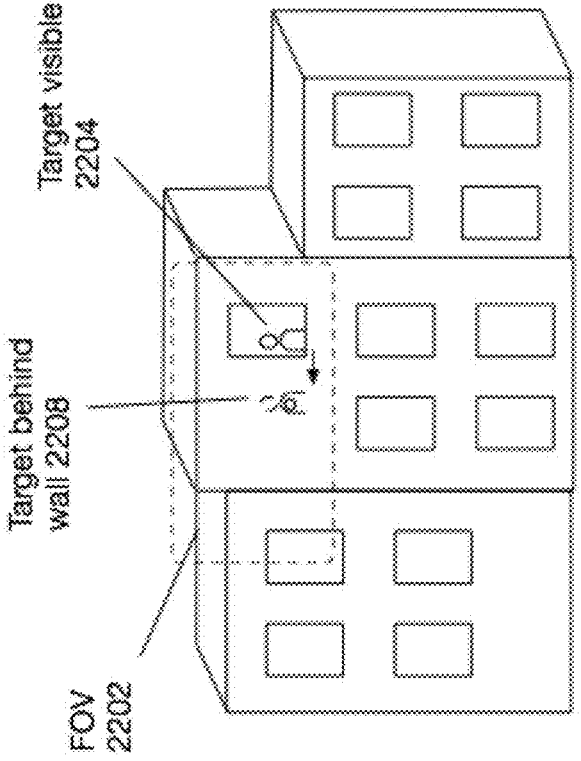

Figure 22

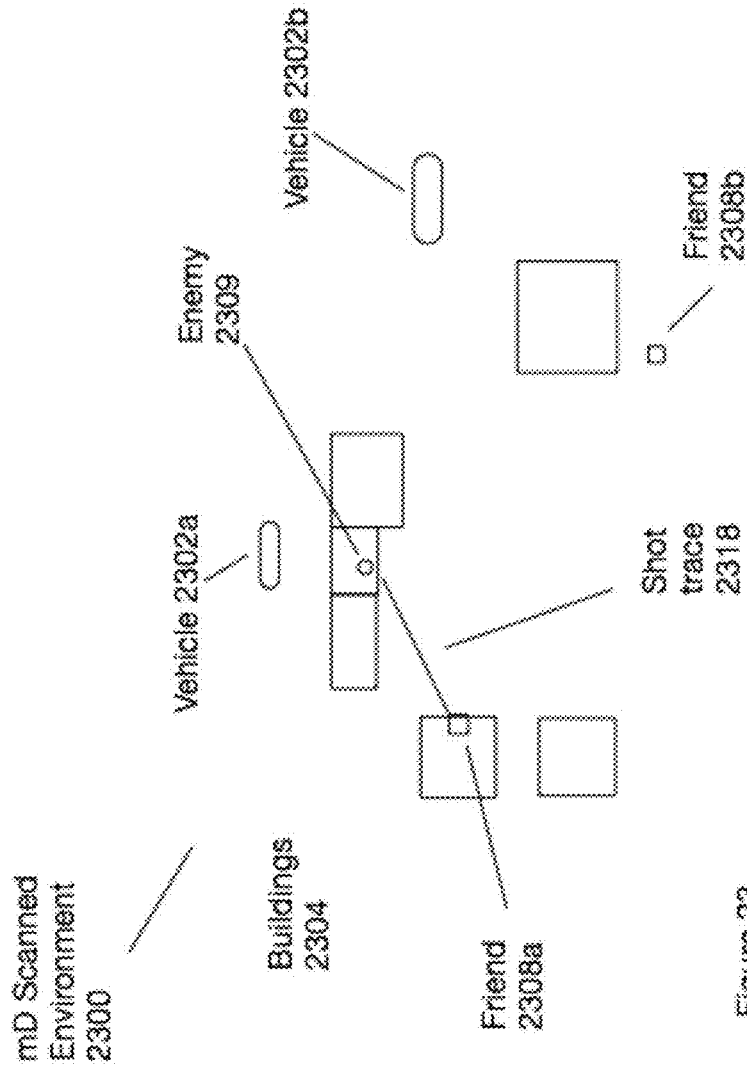

Figure 23

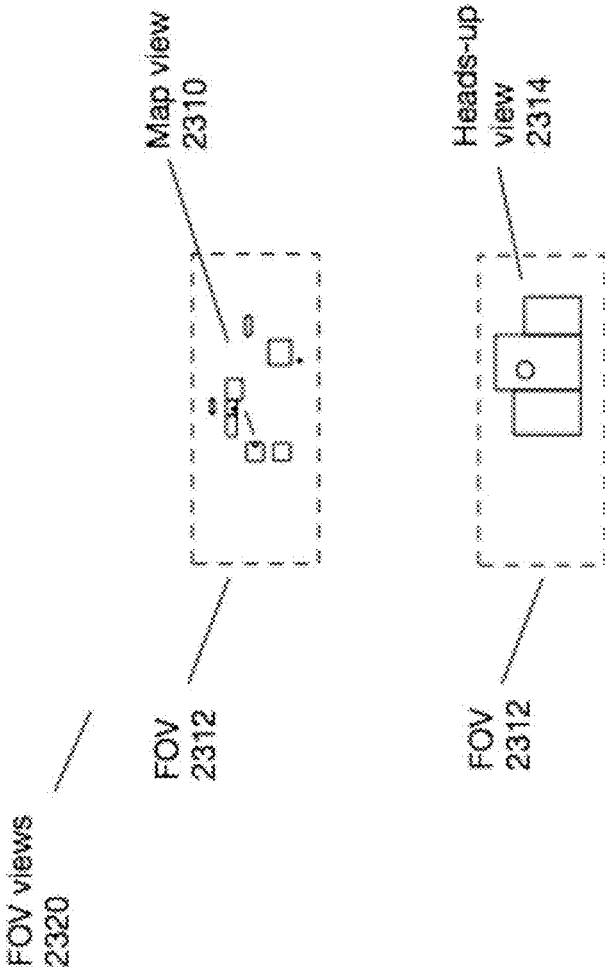

Figure 23a

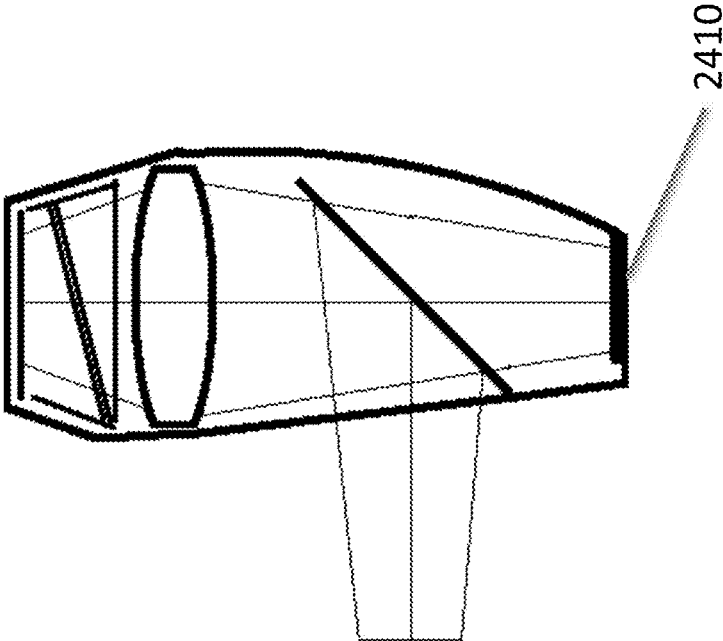

Figure 24

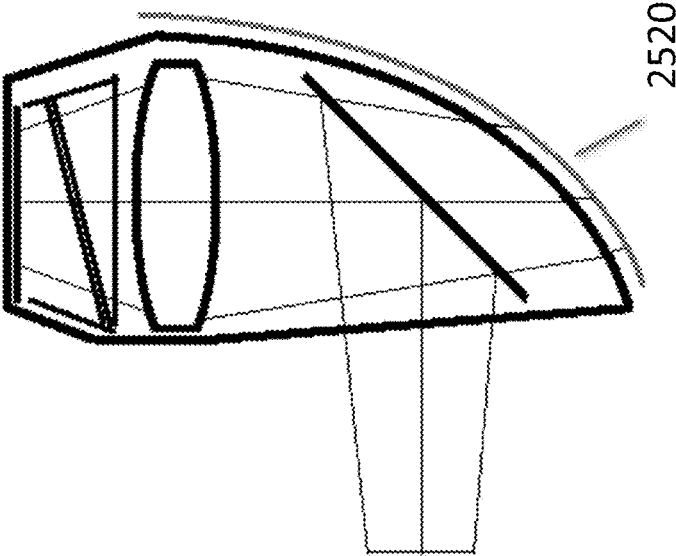

Figure 25

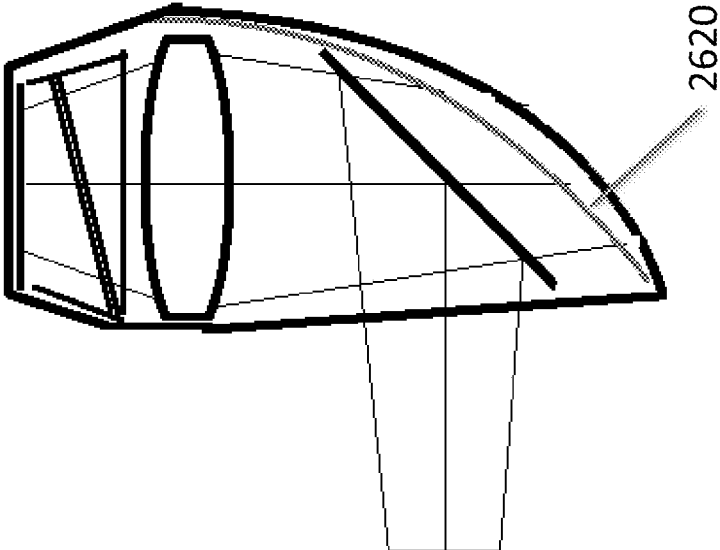

Figure 26

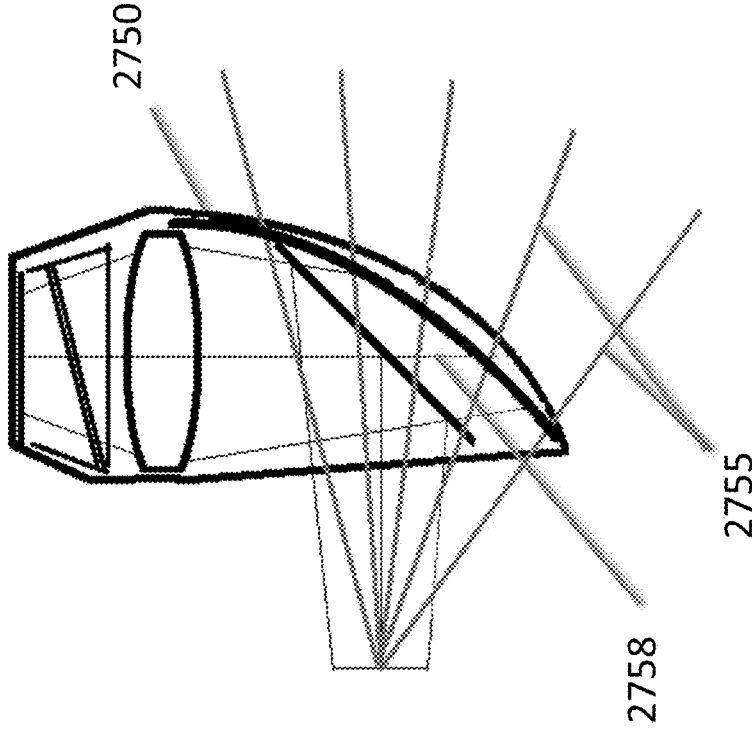

Figure 27

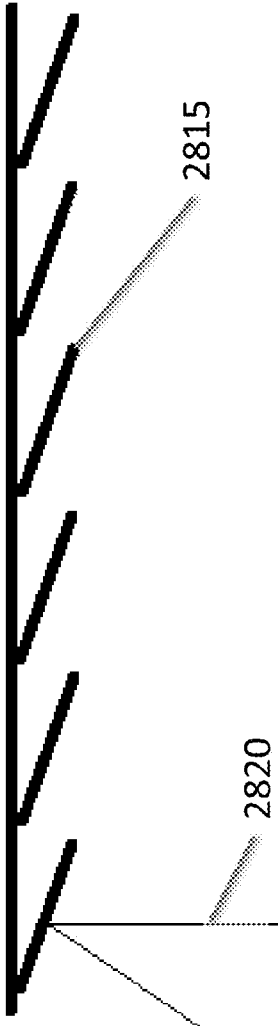

Figure 28a

2810

2820

2815

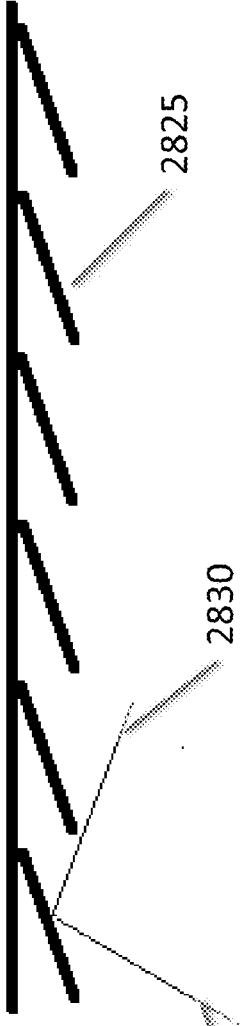

Figure 28b

2810

2830

2825

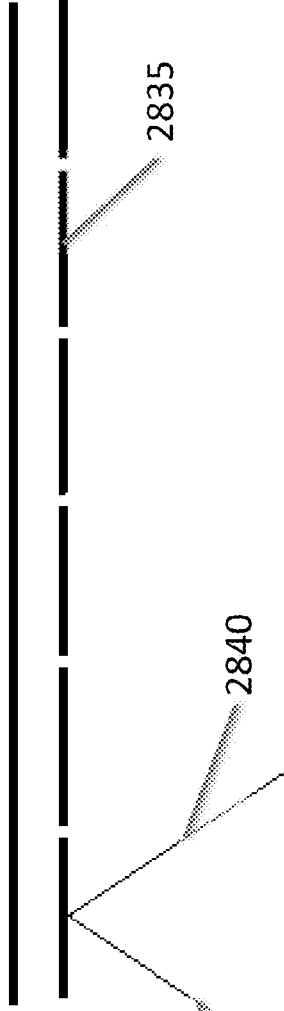

Figure 28c

2810

2840

2835

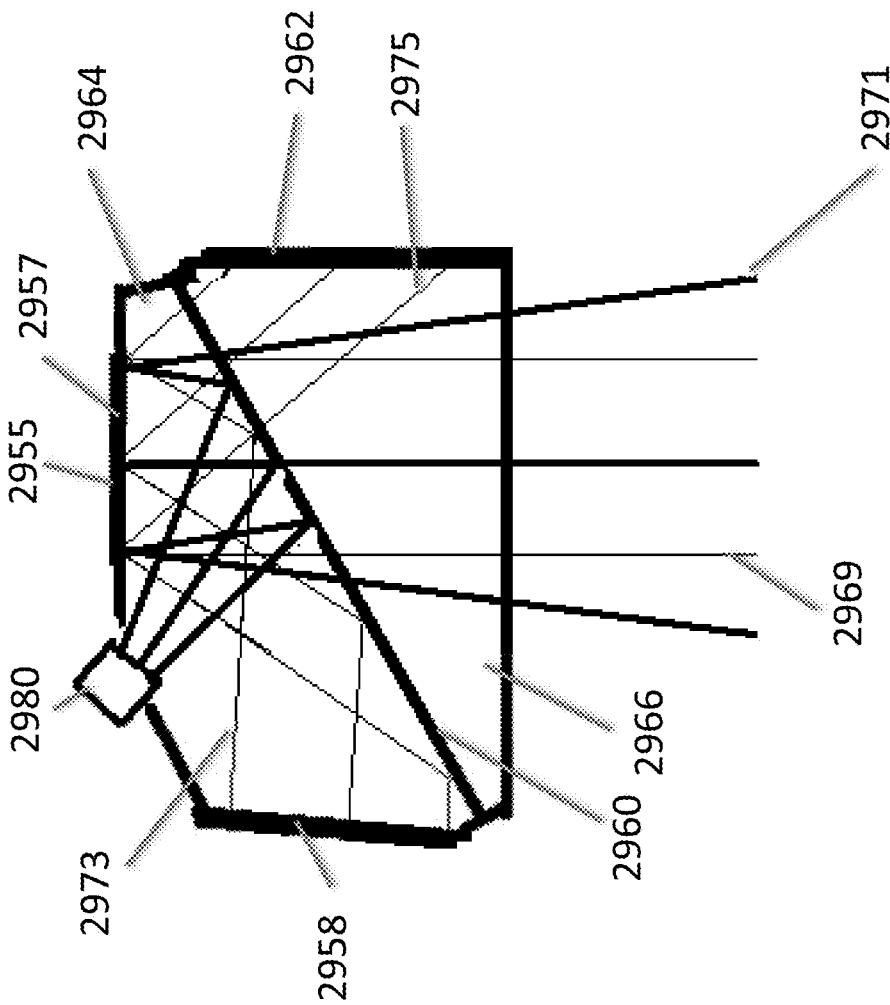

Figure 29

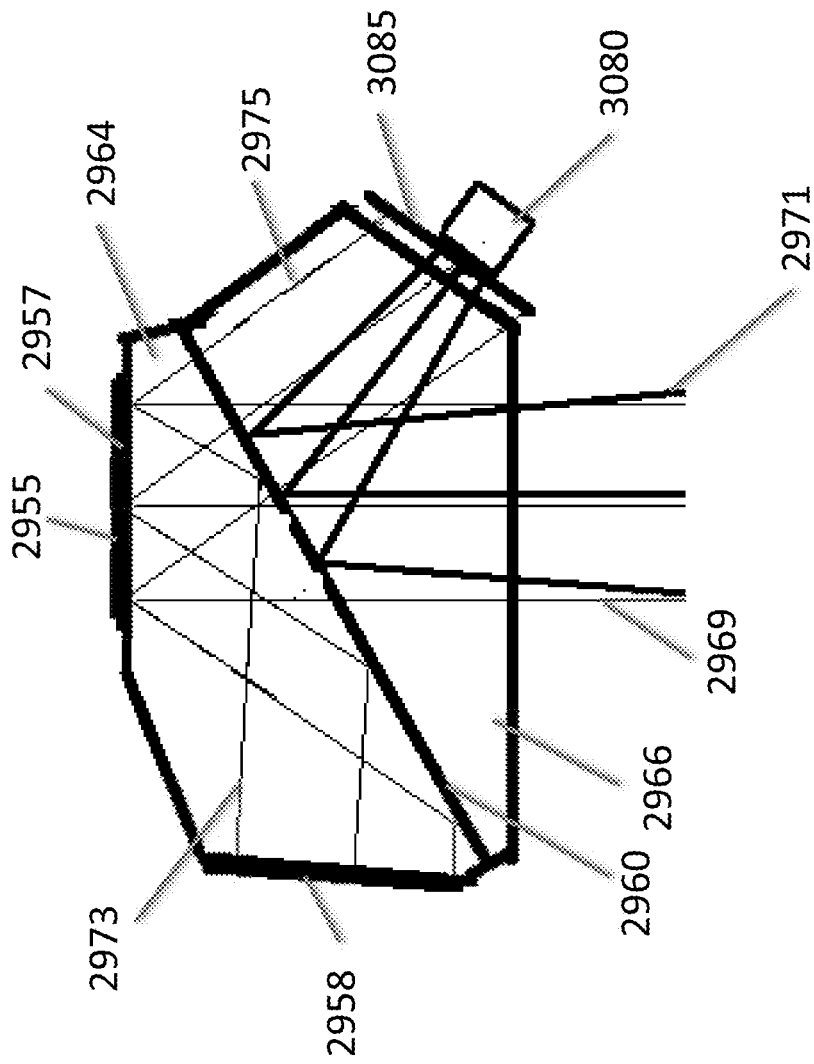

Figure 30

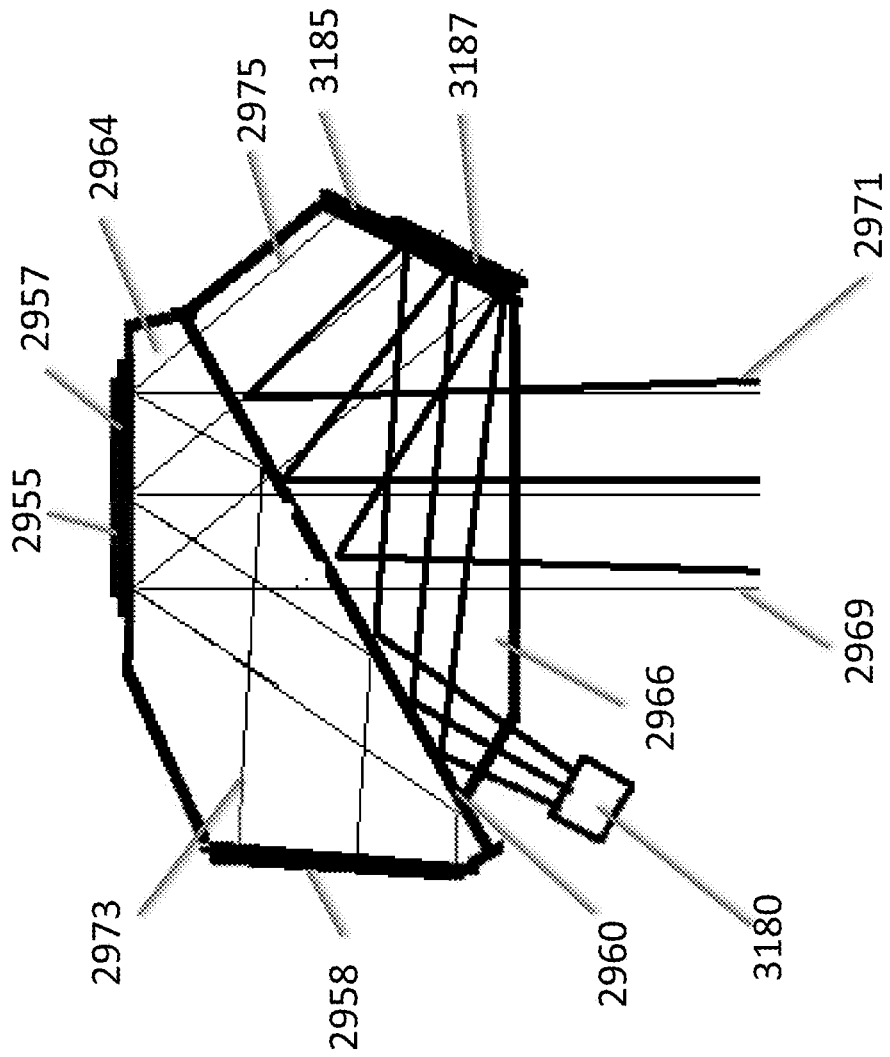

Figure 31

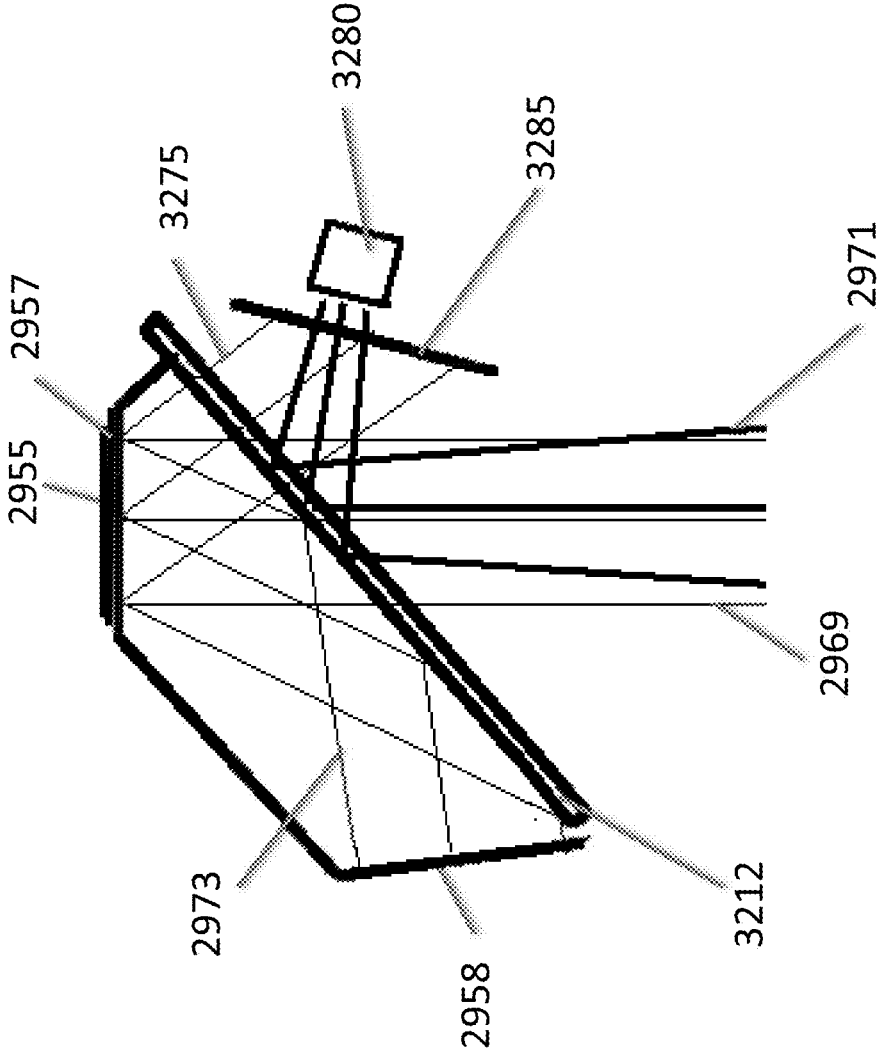

Figure 32

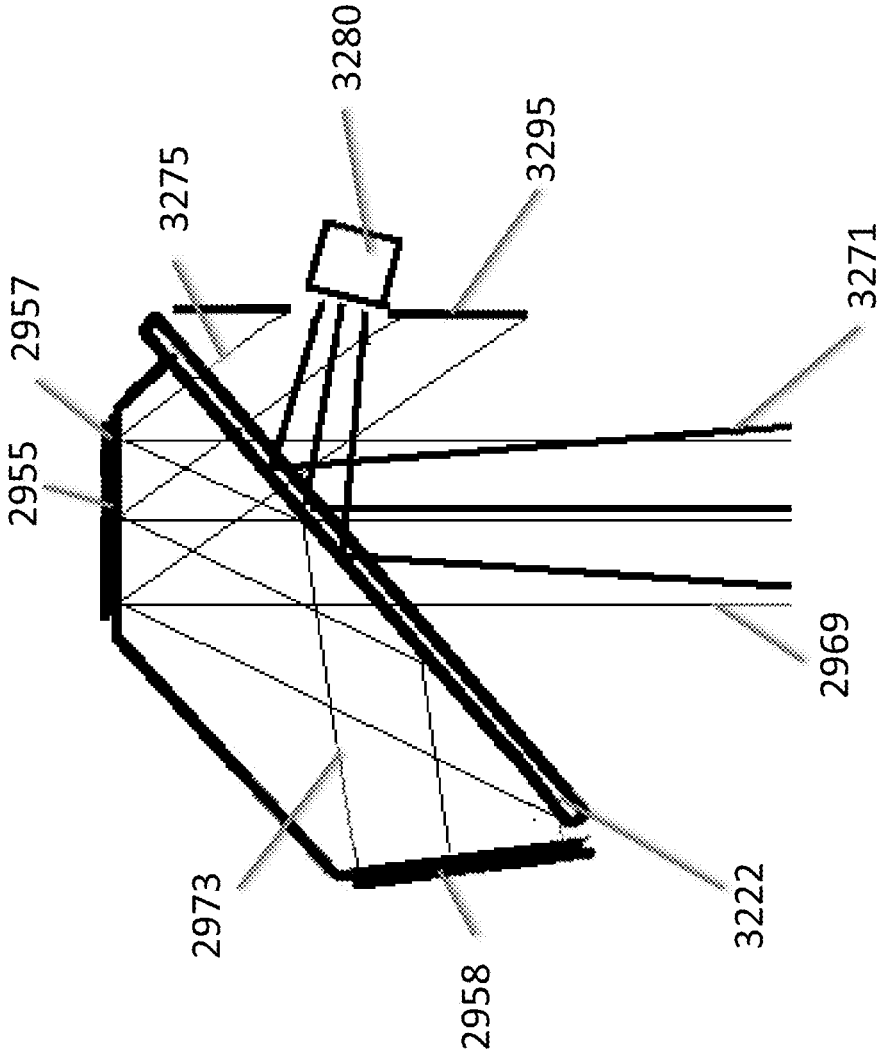

Figure 32a

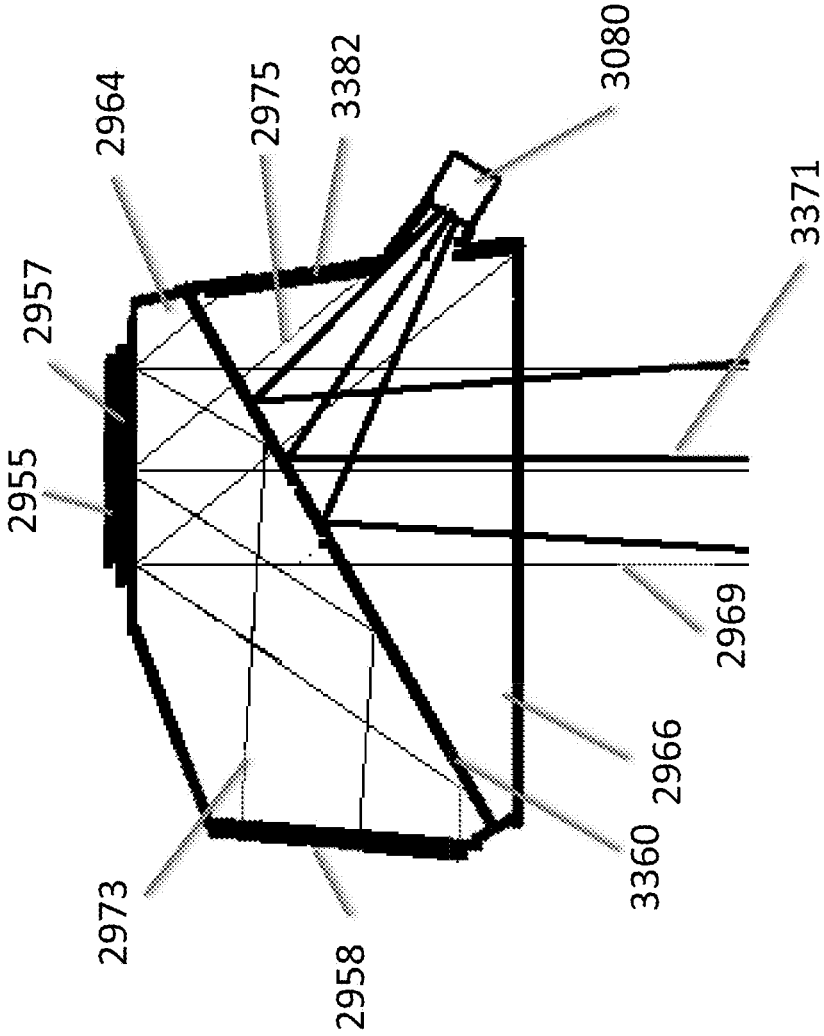

Figure 33

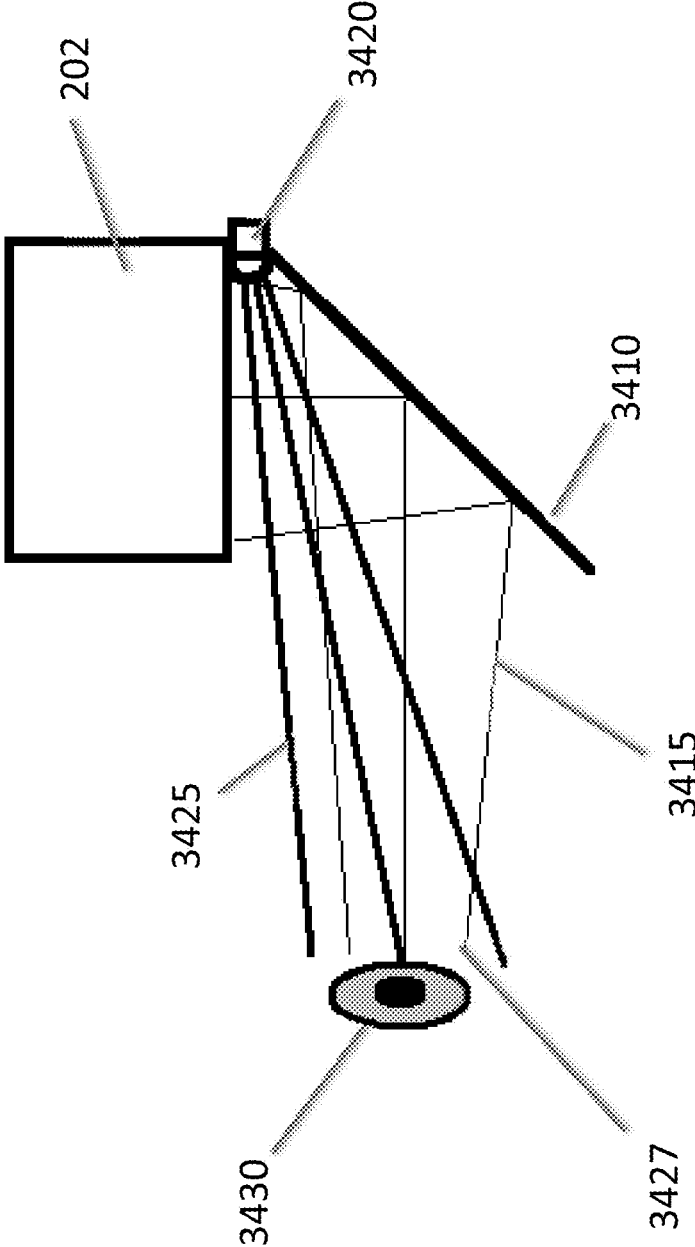

Figure 34

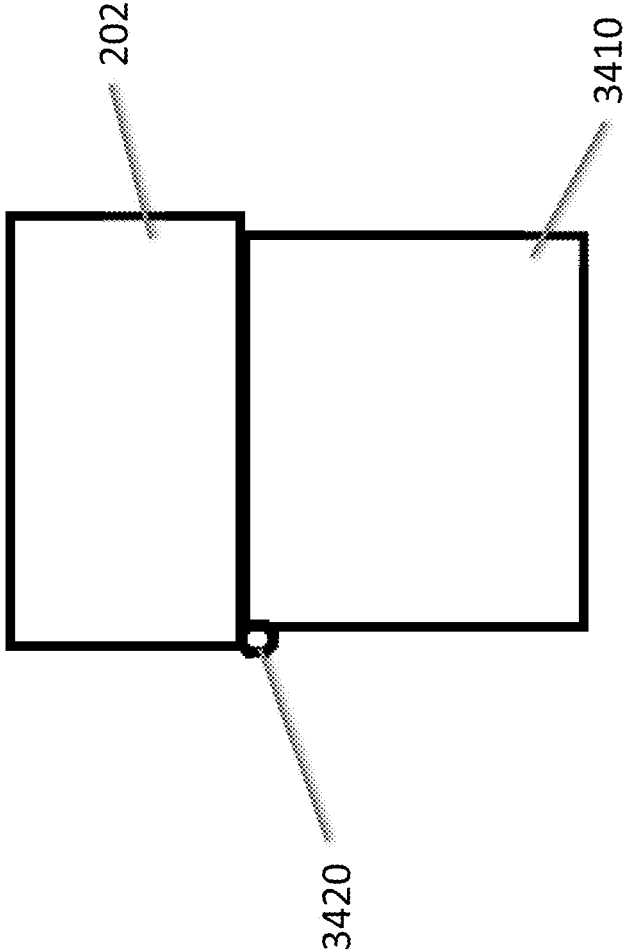

Figure 34a

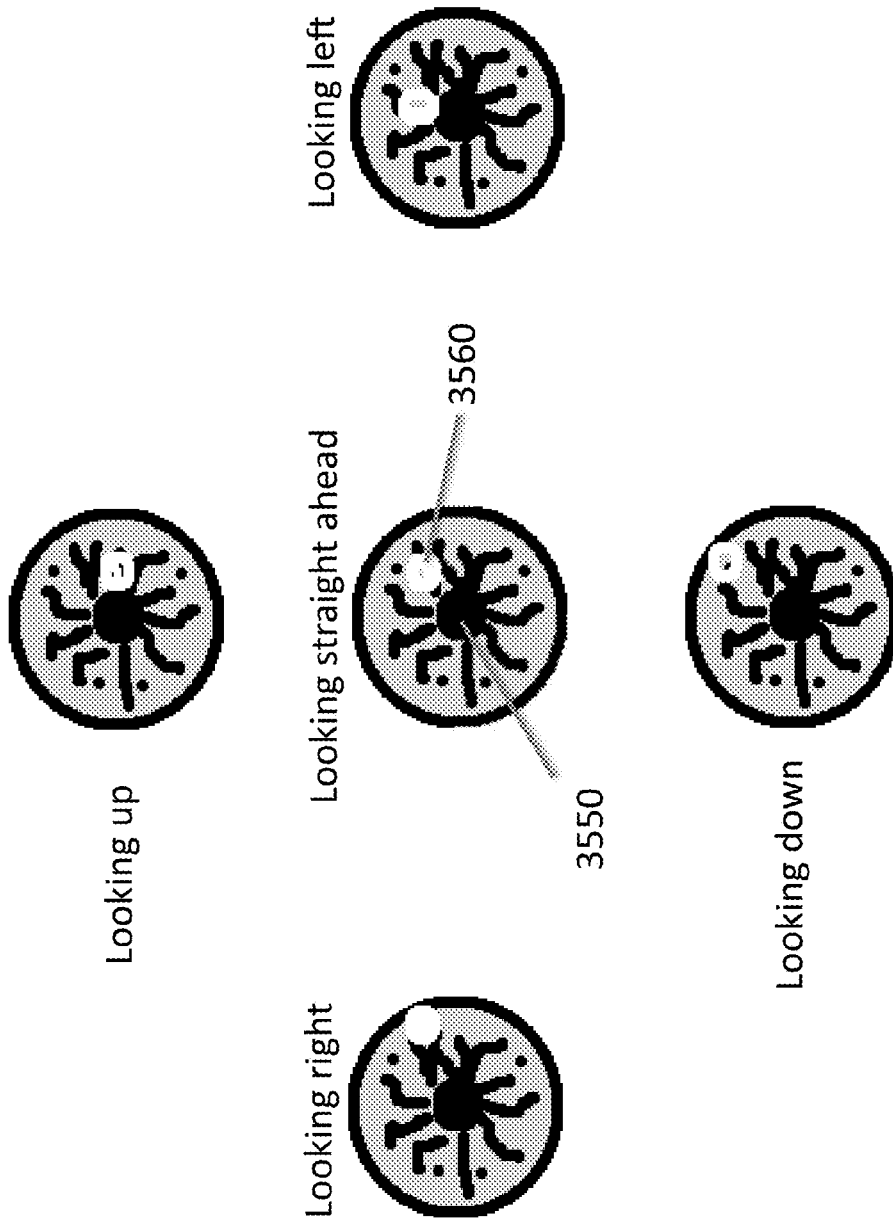

Figure 35

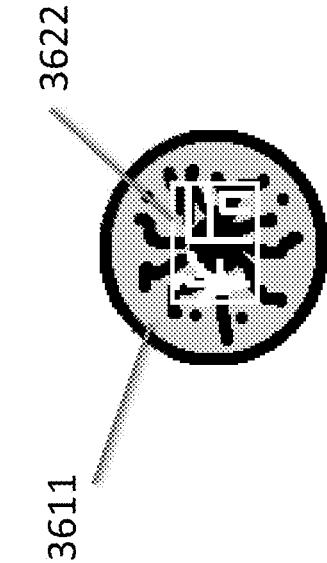

Figure 36a

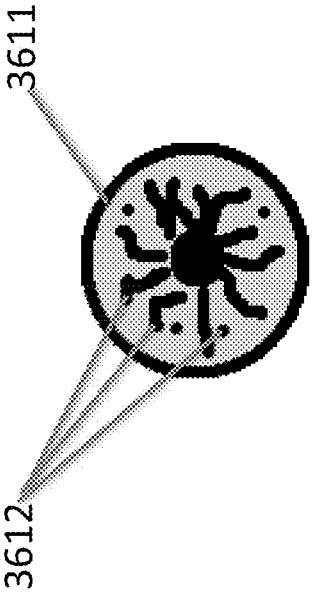

Figure 36b

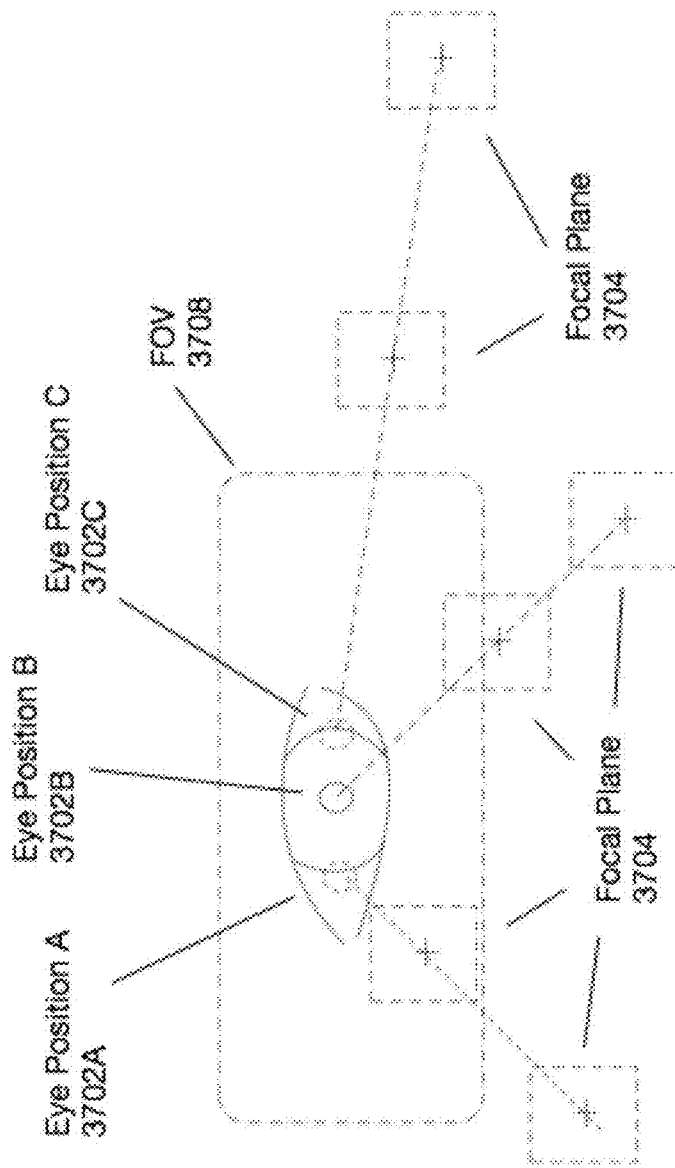

Figure 37

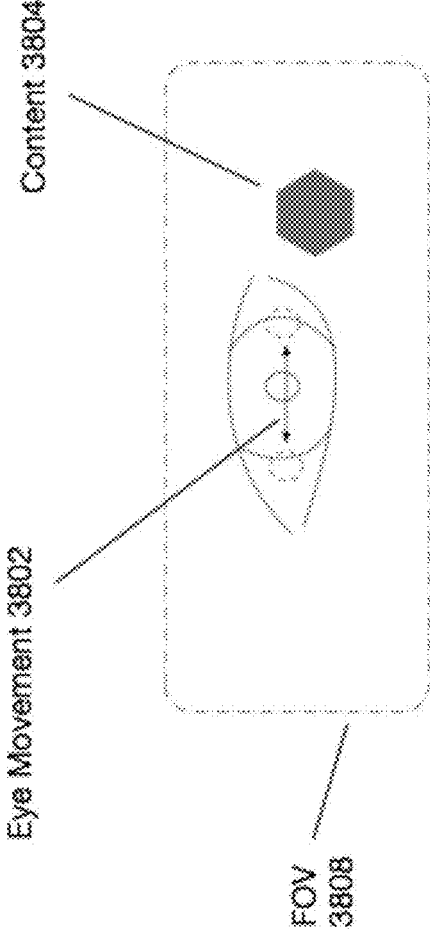

Figure 38

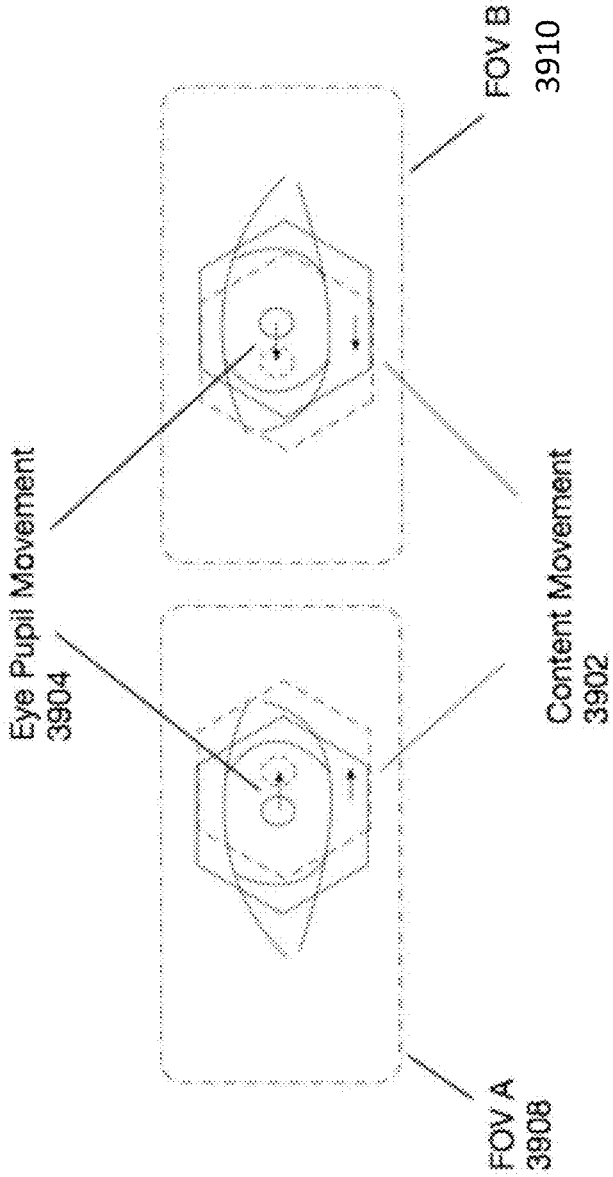

Figure 39

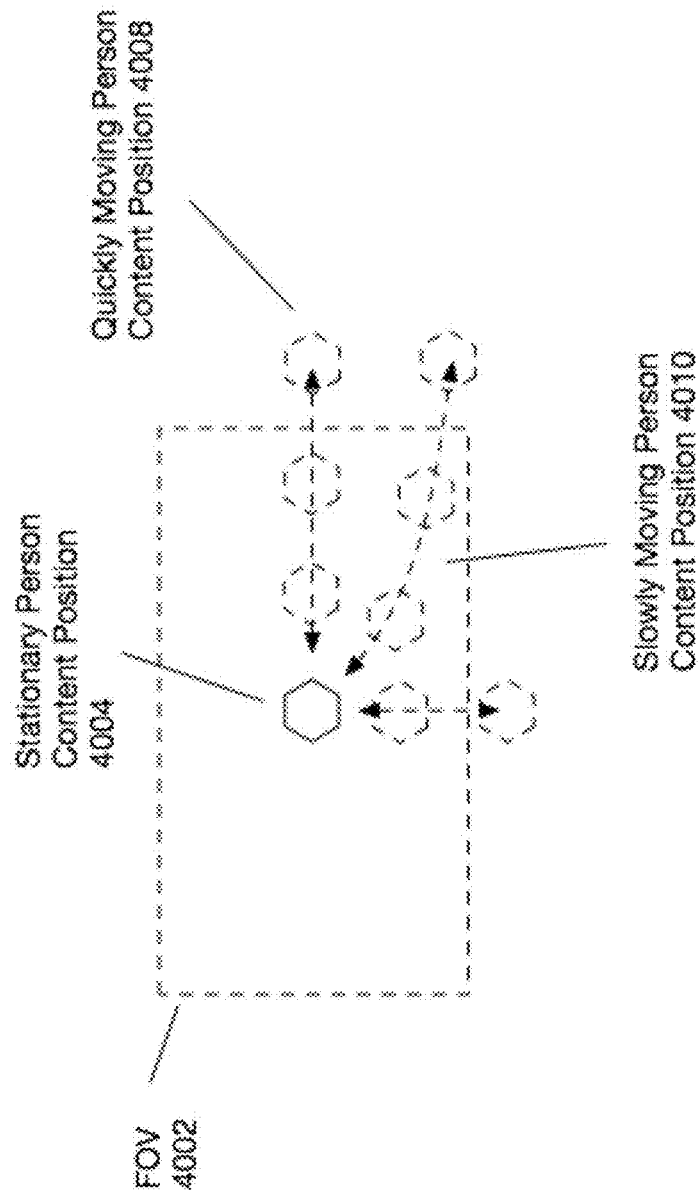

Figure 40

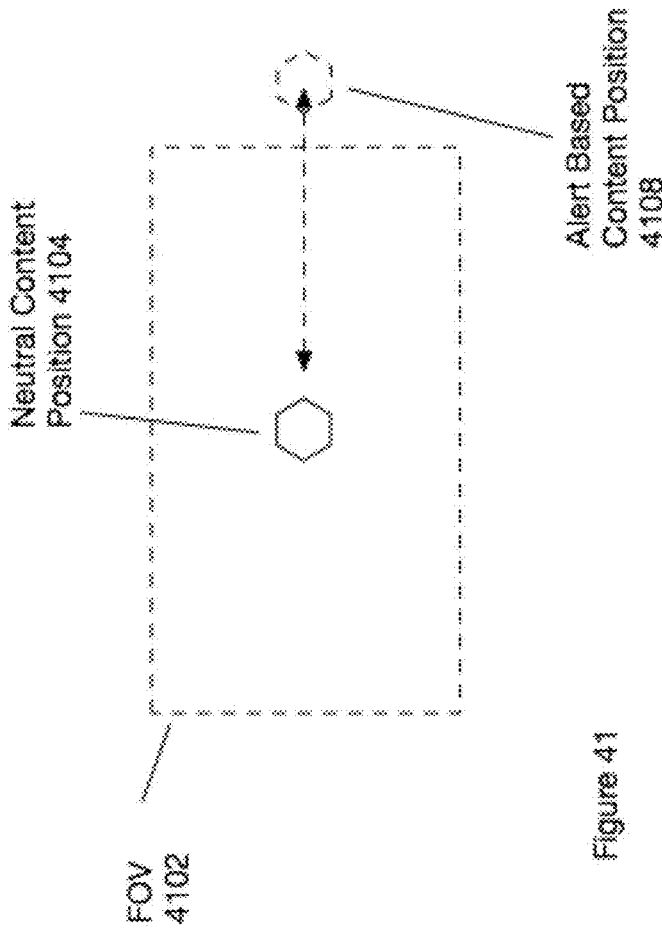

Figure 41

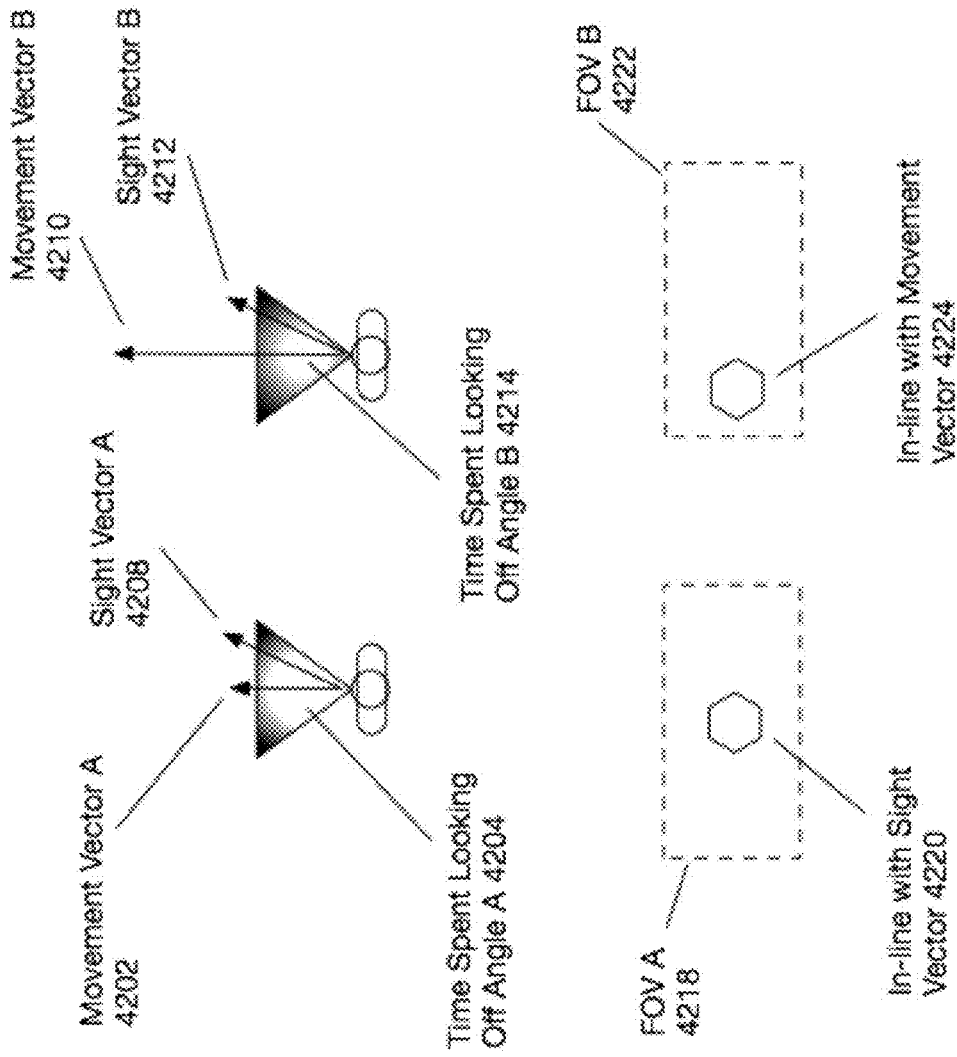

Figure 42

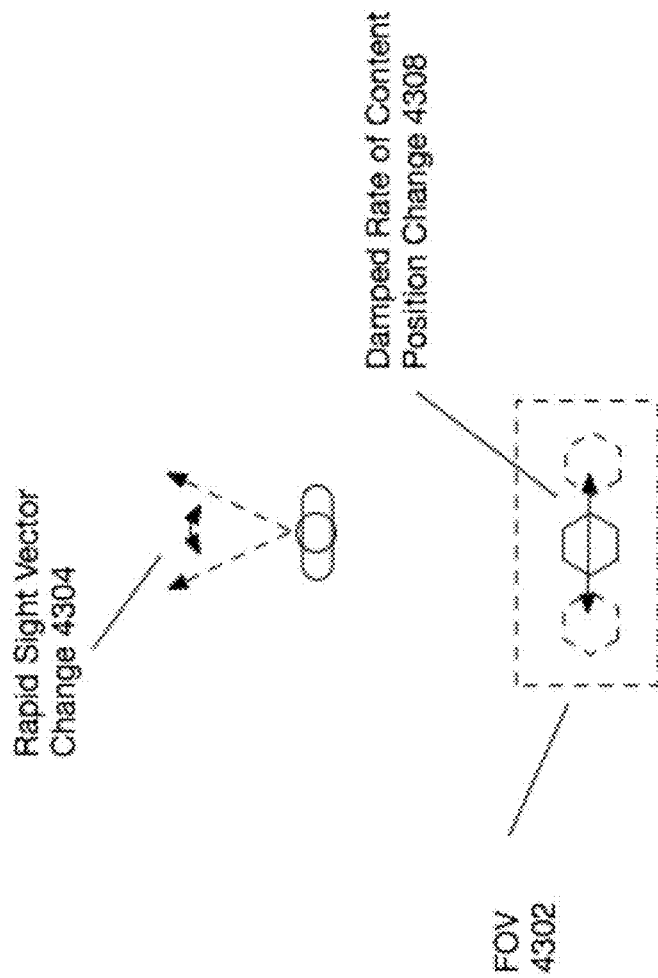

Figure 43

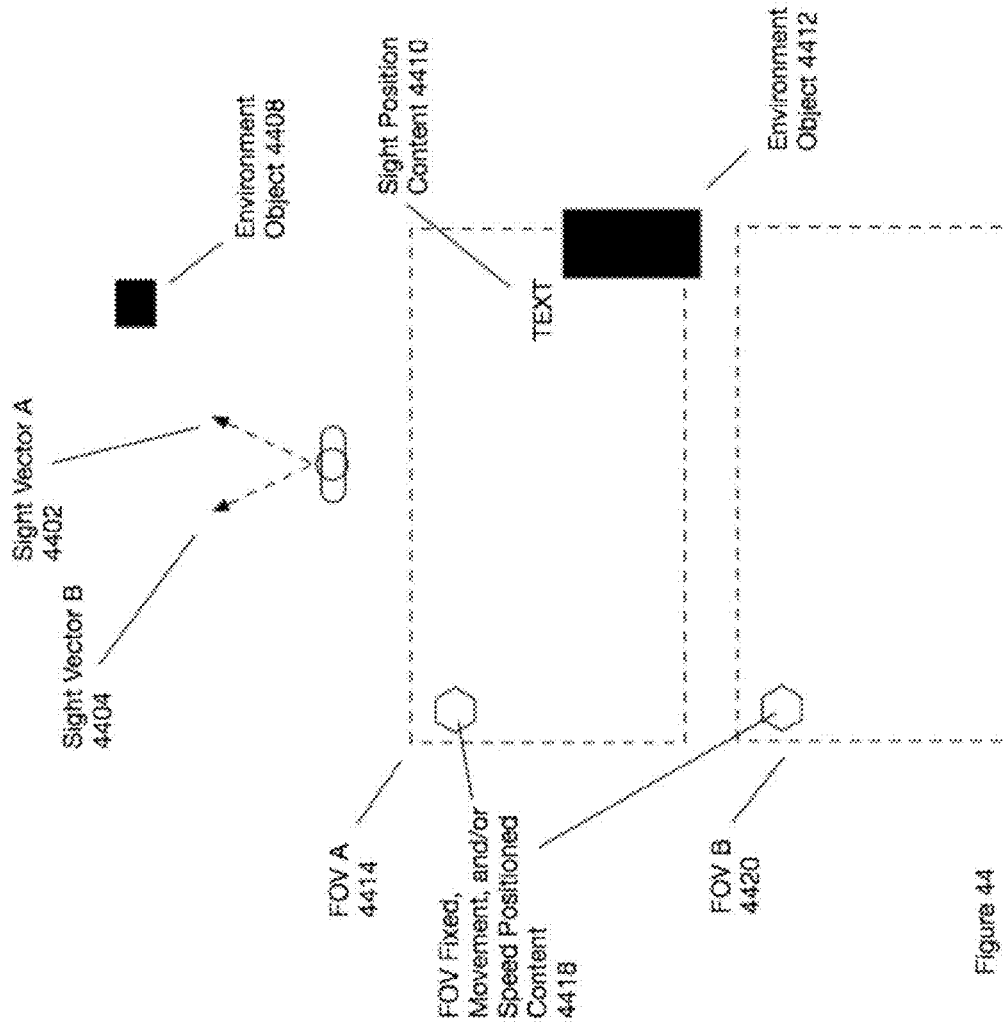

Figure 44

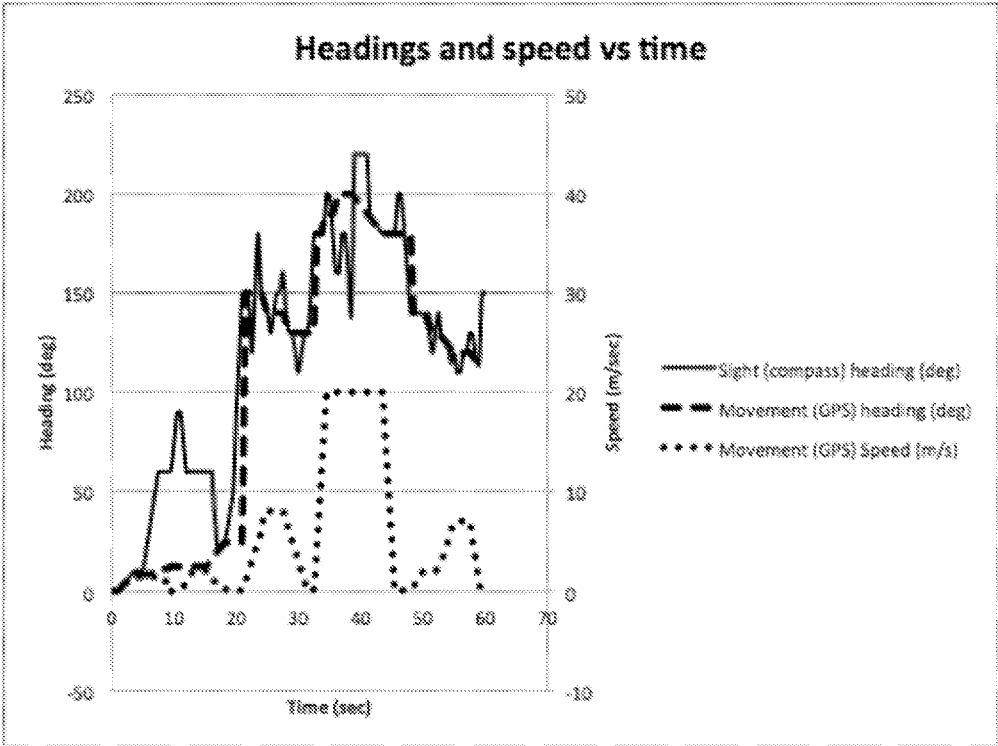

Fig. 45

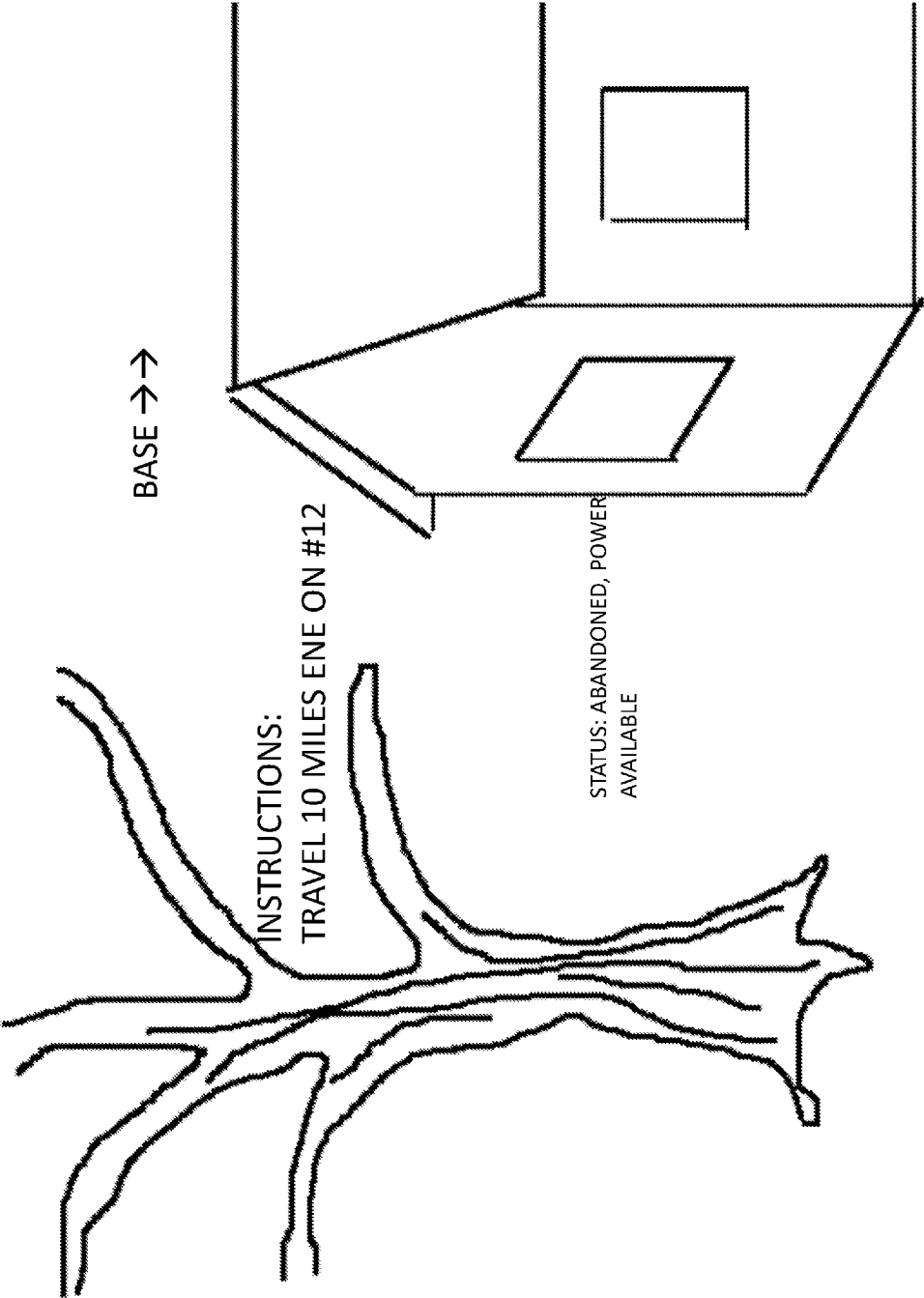
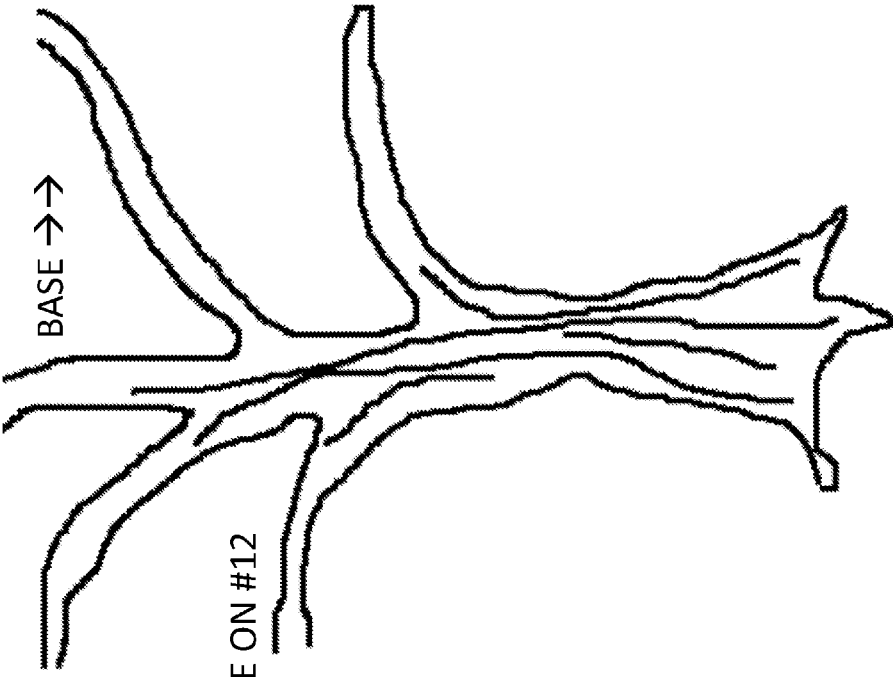

Figure 46



INSTRUCTIONS:
TRAVEL 10 MILES ENE ON #12

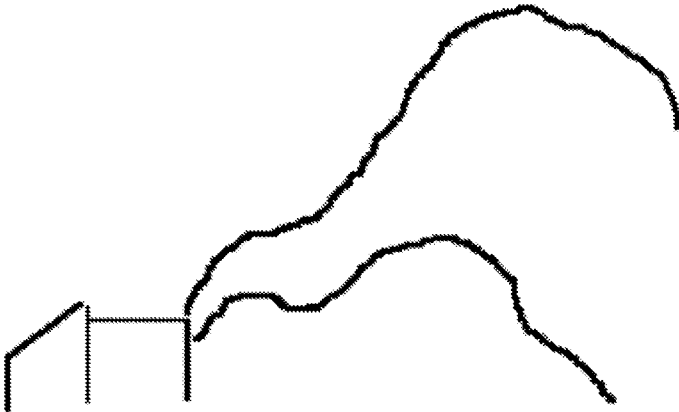
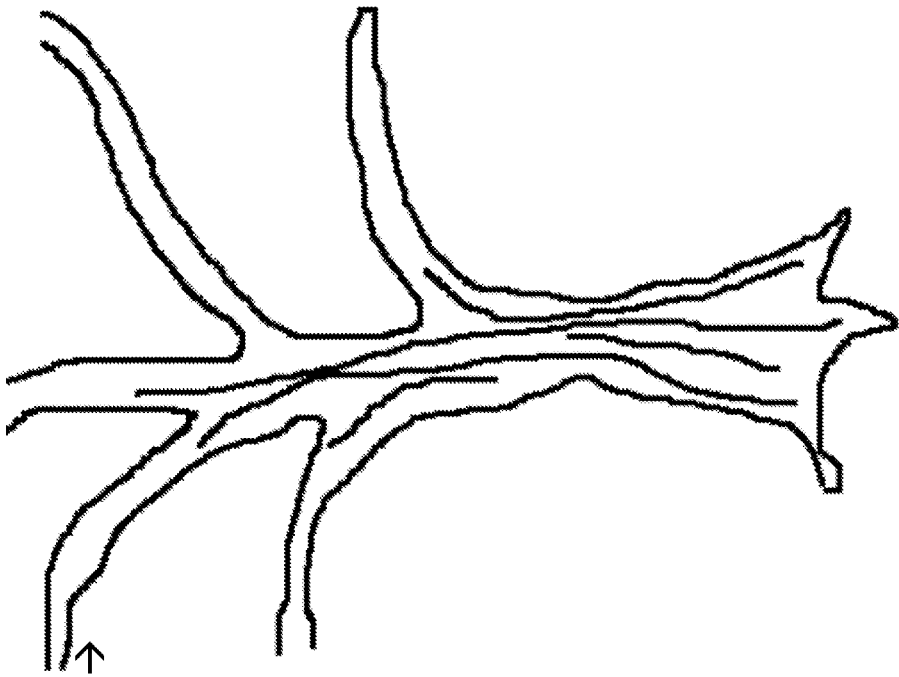

Figure 47



BASE → →

INSTRUCTIONS:
TRAVEL 10 MILES ENE ON #12

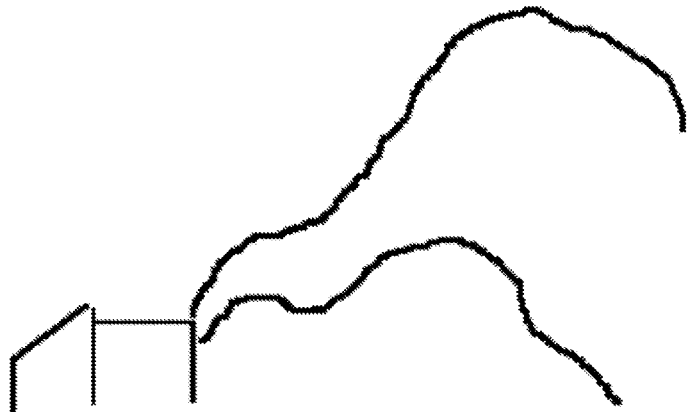

Figure 48

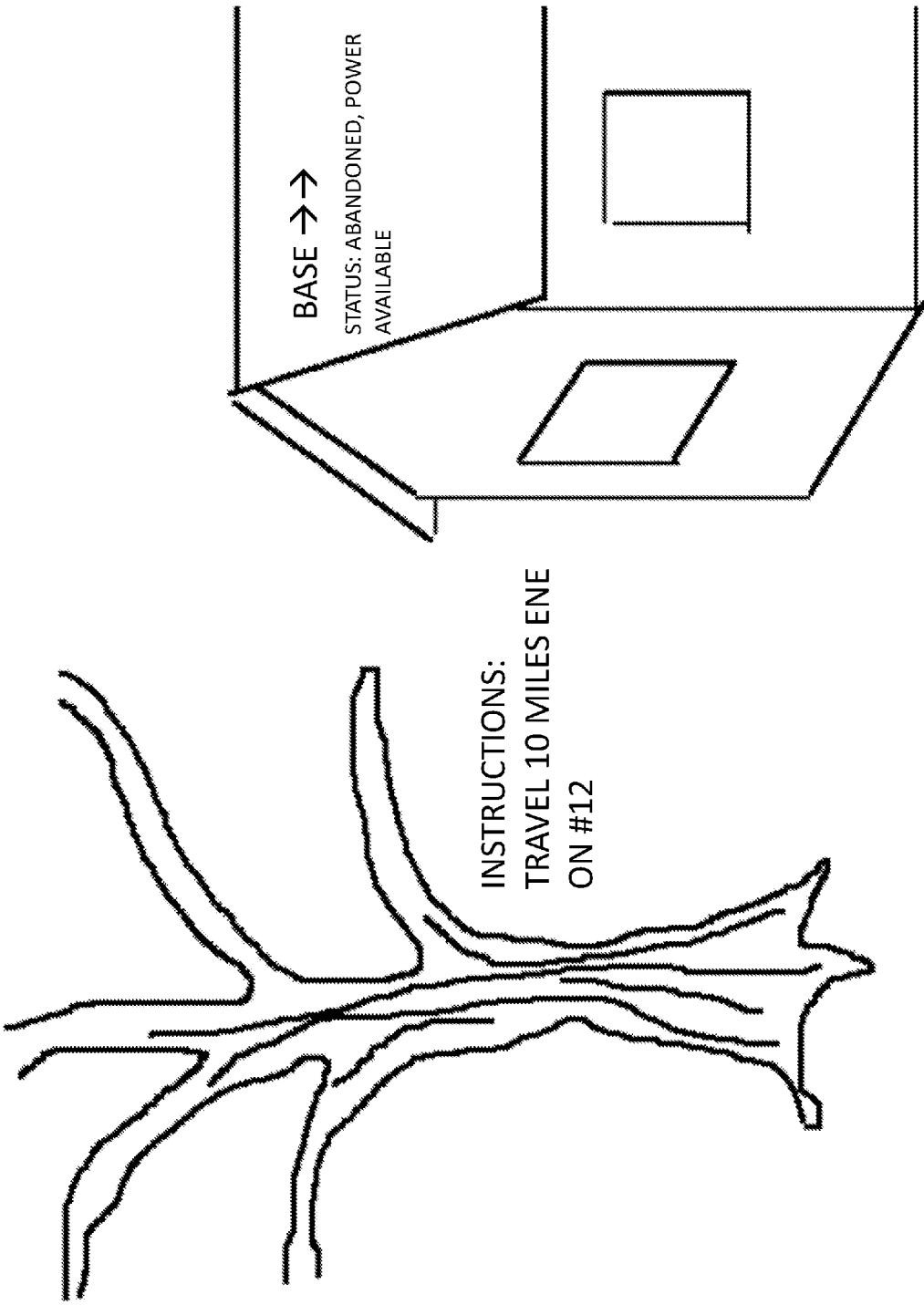

Figure 49

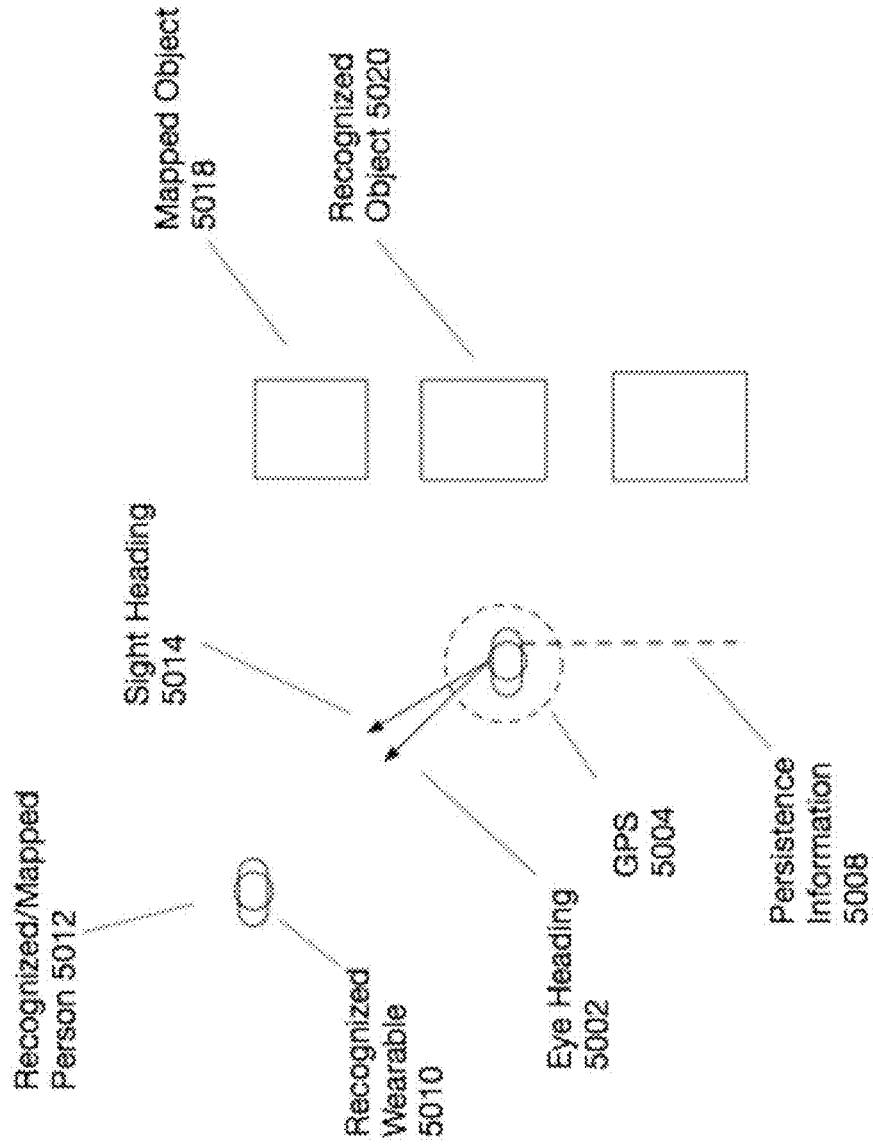

Figure 50

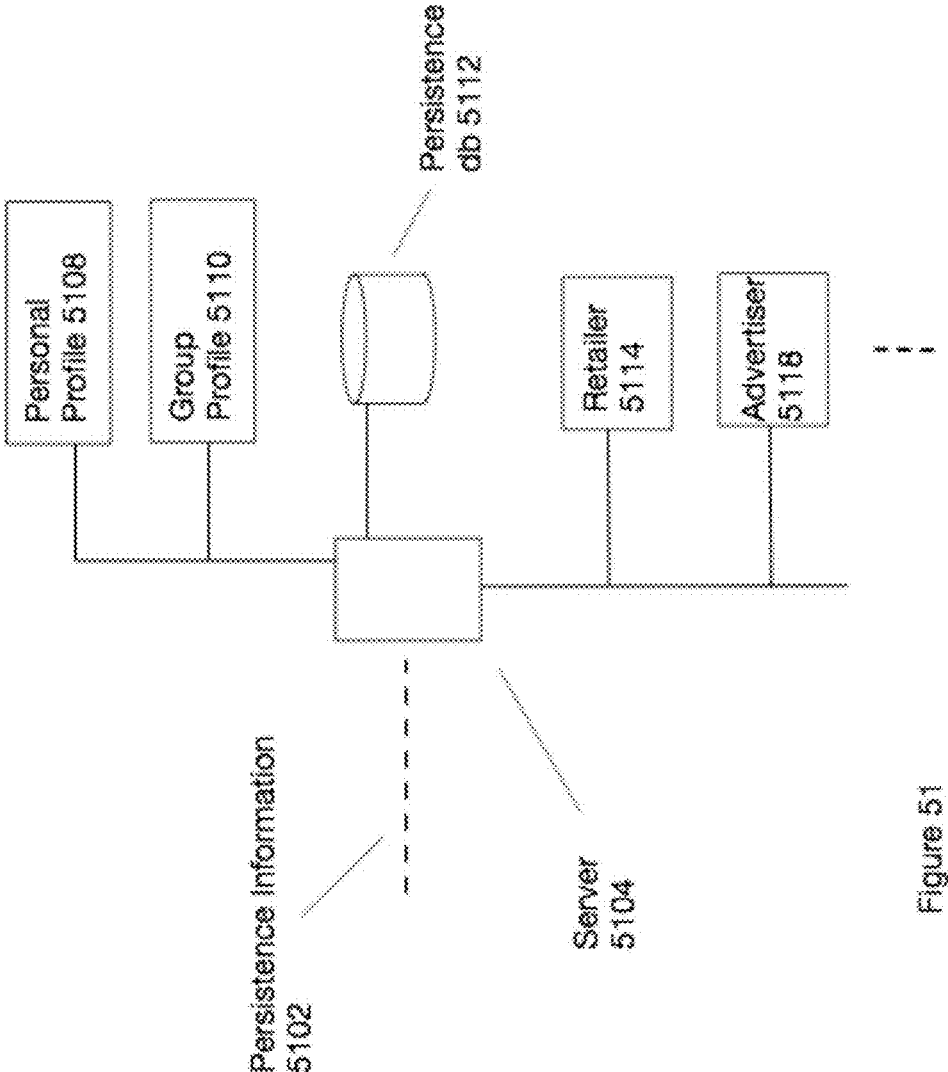

Figure 51

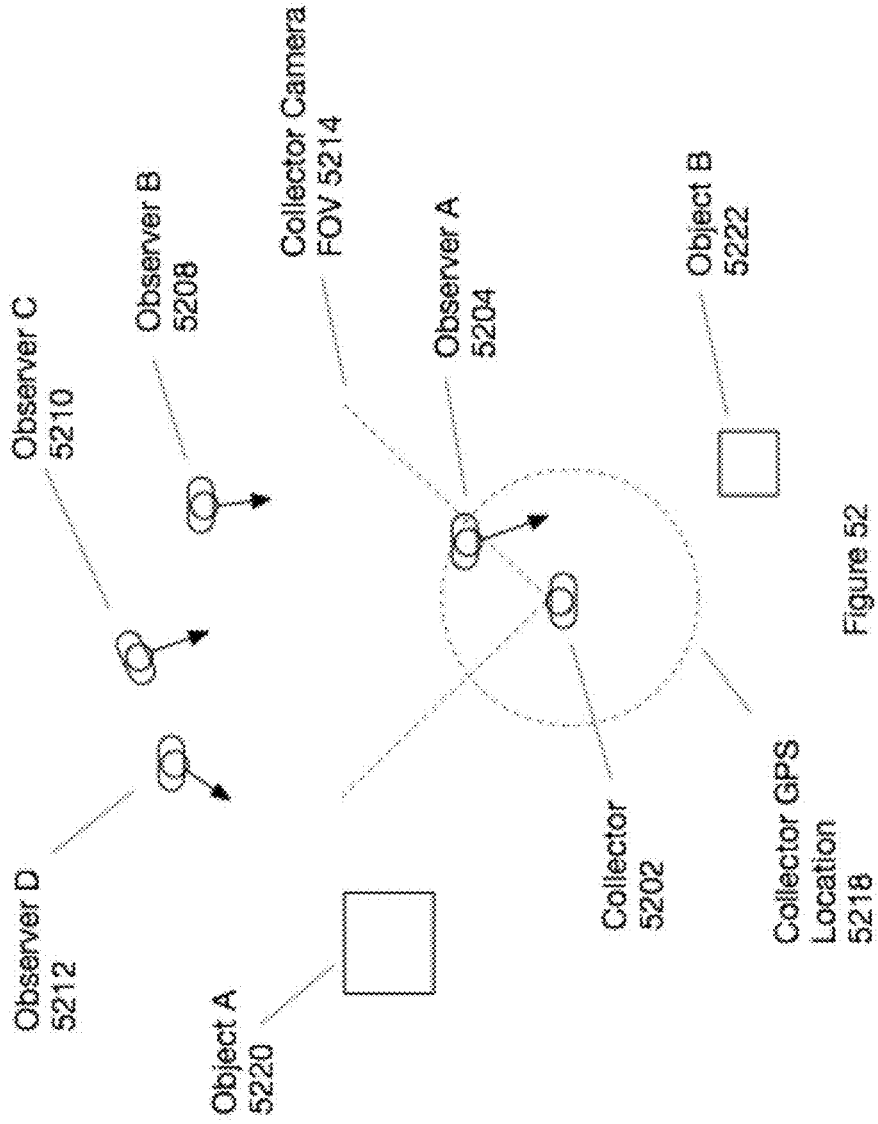

Figure 52

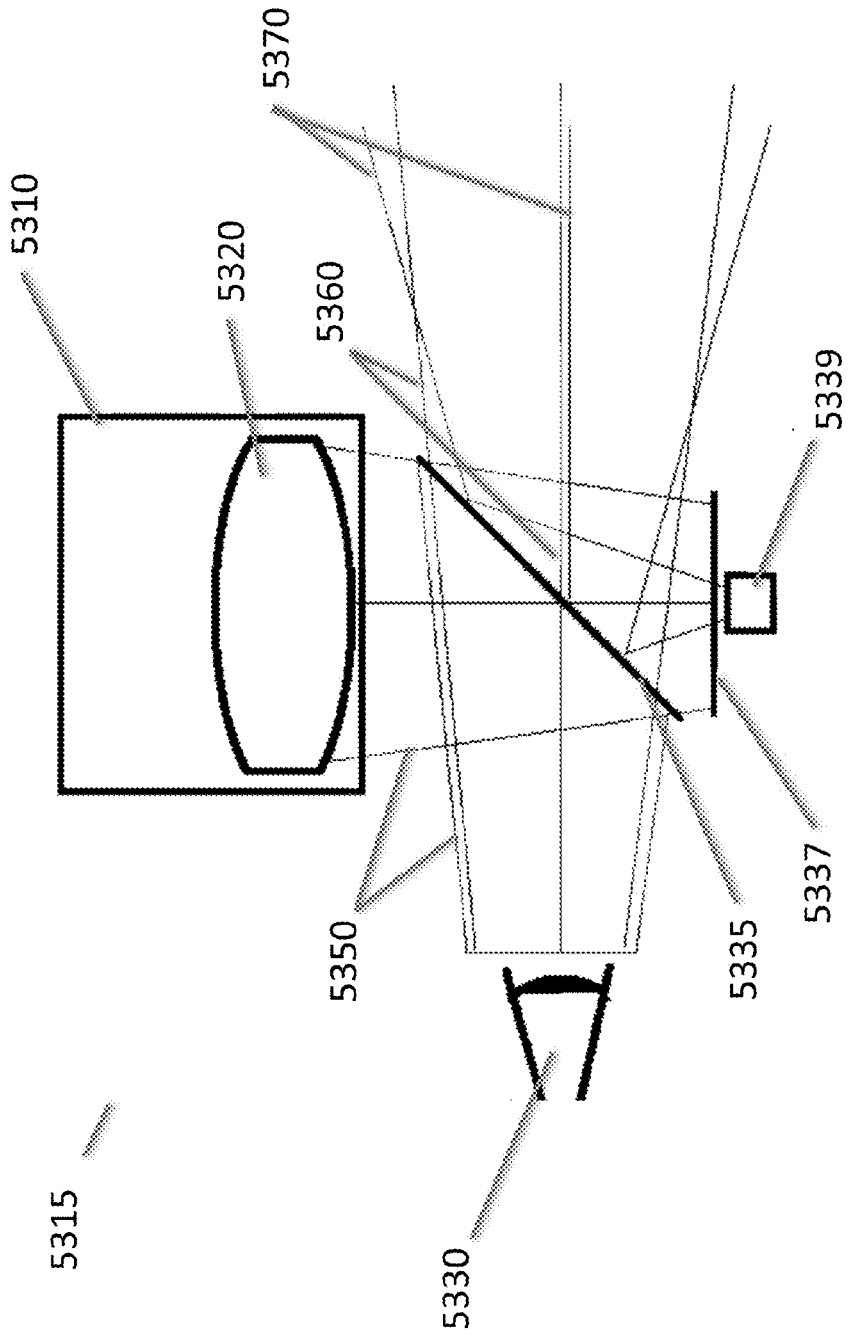

Figure 53

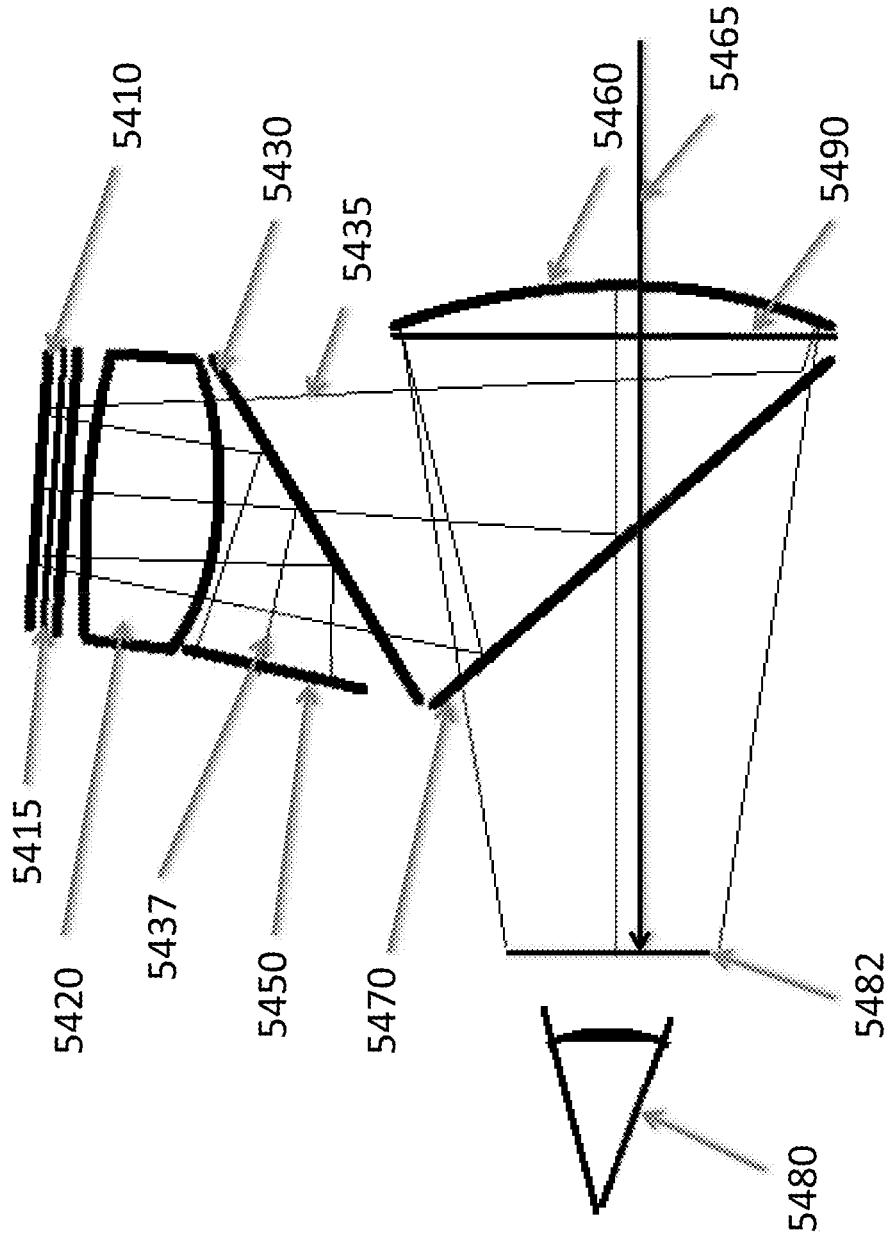

Figure 54

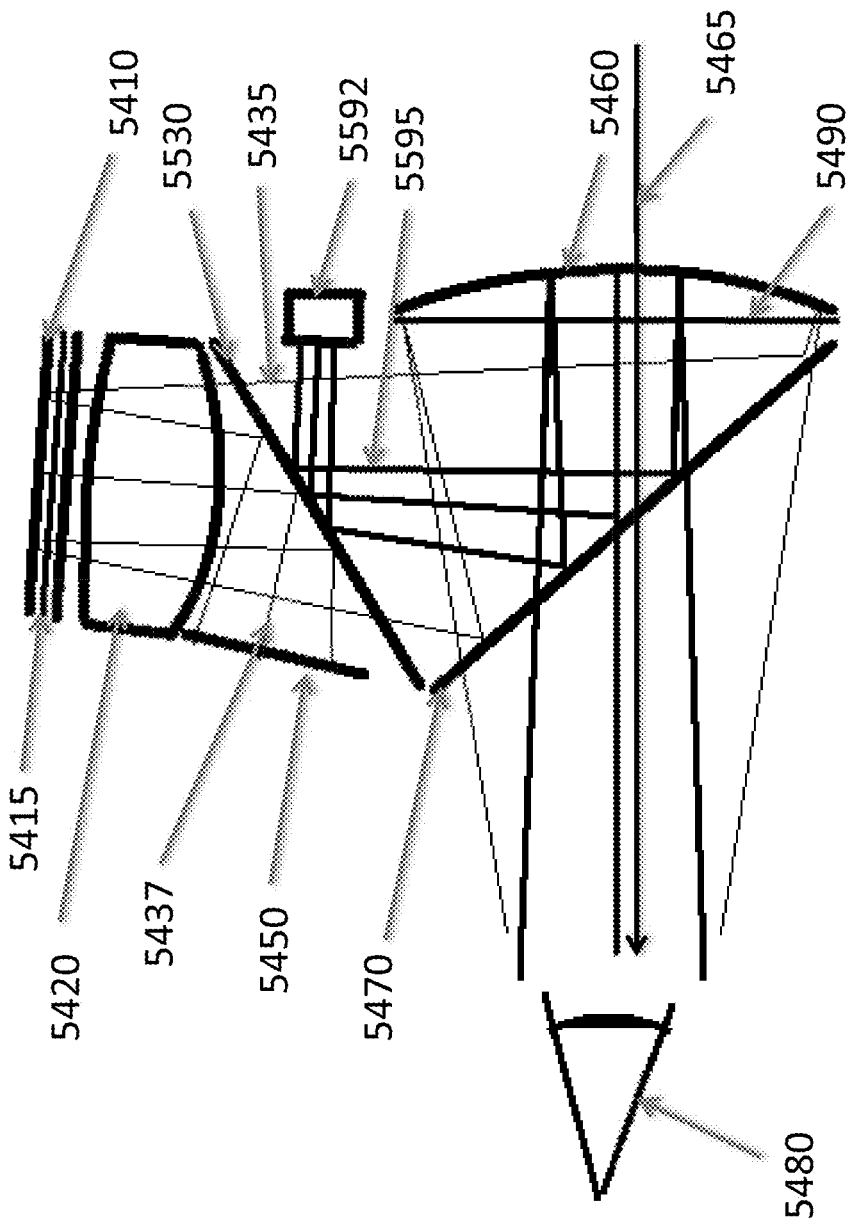

Figure 55

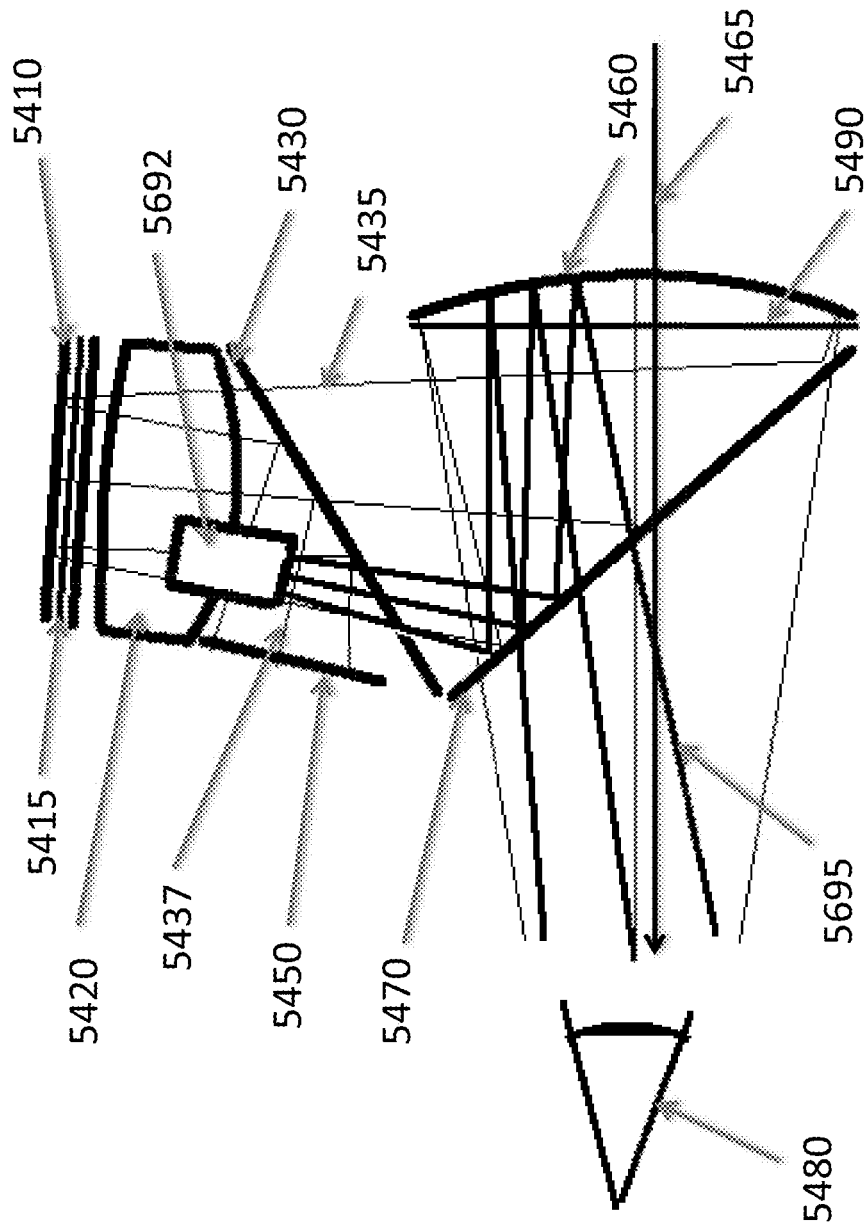

Figure 56

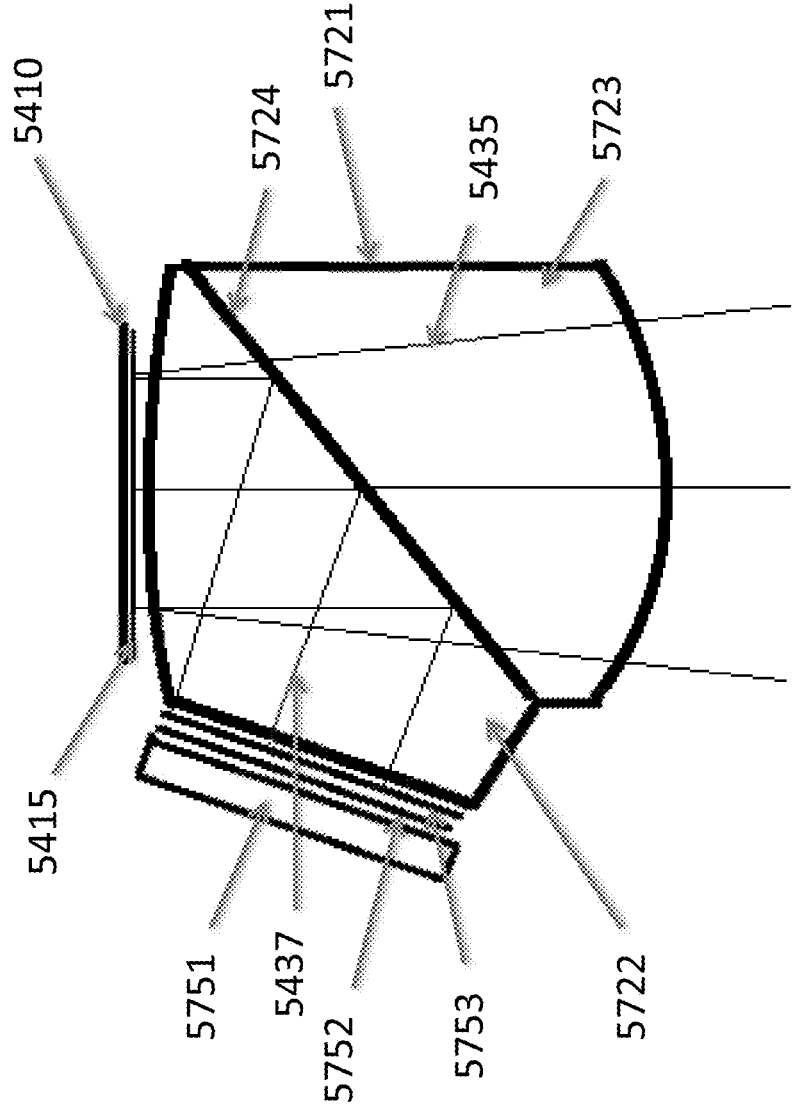

Figure 57

OPTICAL CONFIGURATIONS FOR HEAD-WORN SEE-THROUGH DISPLAYS

CROSS REFERENCE OF RELATED APPLICATIONS

[0001] This application is a continuation of U.S. non-provisional application Ser. No. 15/155,139, filed May 16, 2016 (ODGP-2007-U01-V01) which is a divisional of U.S. non-provisional application Ser. No. 14/325,991, filed Jul. 8, 2014 (ODGP-2007-U01), now U.S. Pat. No. 9,366,867.

[0002] The above-identified applications are incorporated by reference herein in their entirety.

BACKGROUND

Field of the Disclosure

[0003] This disclosure relates to head worn computing. More particularly, this disclosure relates to optical configurations for head-worn see-through computer displays.

Description of Related Art

[0004] Wearable computing systems have been developed and are beginning to be commercialized. Many problems persist in the wearable computing field that need to be resolved to make them meet the demands of the market.

SUMMARY

[0005] Aspects of the present disclosure relate to optical configurations for head-worn see-through computer displays.

[0006] In displays it is typically important to provide a high quality image to the user. In head mounted displays it is important to provide a compact display assembly that is low in weight so the display can be comfortably worn on the head of the user. In head mounted displays that provide a see-through view of the environment, it is also important to provide a high contrast displayed image with black blacks so the environment can be easily viewed. Optical systems of the present disclosures are small, light-weight and produce high image quality in a head-worn see-through device.

[0007] Systems and methods described herein provide upper optics comprised of a reflective display, a field lens, a reflective polarizer and a light source. The optical layout of the illumination optical path and the imaging optical path are overlapped to reduce the overall size of the optics package. In embodiments, a flat reflective polarizer is used both to redirect polarized illumination light toward a reflective image source and to act as the analyzer polarizer on the image light thereby enabling more compact optics and reducing the weight of the display assembly. In embodiments where the reflective polarizer is flat, the illumination light is provided with a central light ray at about 45 degrees, high incident angle surfaces are avoided to reduce scattered light and thereby enable increased contrast in the displayed image. Further, the flat reflective polarizer can be a film or a coating to reduce weight. Space is provided at the surface of the reflective image source so that a compensator film can be provided on the reflective image source to provide a higher contrast image to the user.

[0008] In embodiments, the lower optics comprising a beam splitter, a quarter wave film and a rotationally curved partial mirror, are largely comprised of air to provide a compact display assembly that has very low weight. In

addition, in embodiments, the optical surfaces in the imaging optics are all either on axis or flat to thereby preserve the wavefront of the image light and thereby provide a high image quality.

[0009] These and other systems, methods, objects, features, and advantages of the present disclosure will be apparent to those skilled in the art from the following detailed description of the preferred embodiment and the drawings. All documents mentioned herein are hereby incorporated in their entirety by reference.

BRIEF DESCRIPTION OF THE DRAWINGS

[0010] Embodiments are described with reference to the following Figures. The same numbers may be used throughout to reference like features and components that are shown in the Figures:

[0011] FIG. 1 illustrates a head worn computing system in accordance with the principles of the present disclosure.

[0012] FIG. 2 illustrates a head worn computing system with optical system in accordance with the principles of the present disclosure.

[0013] FIG. 3a illustrates a large prior art optical arrangement.

[0014] FIG. 3b illustrates an upper optical module in accordance with the principles of the present disclosure.

[0015] FIG. 4 illustrates an upper optical module in accordance with the principles of the present disclosure.

[0016] FIG. 4a illustrates an upper optical module in accordance with the principles of the present disclosure.

[0017] FIG. 4b illustrates an upper optical module in accordance with the principles of the present disclosure.

[0018] FIG. 5 illustrates an upper optical module in accordance with the principles of the present disclosure.

[0019] FIG. 5a illustrates an upper optical module in accordance with the principles of the present disclosure.

[0020] FIG. 5b illustrates an upper optical module and dark light trap according to the principles of the present disclosure.

[0021] FIG. 5c illustrates an upper optical module and dark light trap according to the principles of the present disclosure.

[0022] FIG. 5d illustrates an upper optical module and dark light trap according to the principles of the present disclosure.

[0023] FIG. 5e illustrates an upper optical module and dark light trap according to the principles of the present disclosure.

[0024] FIG. 6 illustrates upper and lower optical modules in accordance with the principles of the present disclosure.

[0025] FIG. 7 illustrates angles of combiner elements in accordance with the principles of the present disclosure.

[0026] FIG. 8 illustrates upper and lower optical modules in accordance with the principles of the present disclosure.

[0027] FIG. 8a illustrates upper and lower optical modules in accordance with the principles of the present disclosure.

[0028] FIG. 8b illustrates upper and lower optical modules in accordance with the principles of the present disclosure.

[0029] FIG. 8c illustrates upper and lower optical modules in accordance with the principles of the present disclosure.

[0030] FIG. 9 illustrates an eye imaging system in accordance with the principles of the present disclosure.

[0031] FIG. 10 illustrates a light source in accordance with the principles of the present disclosure.

[0032] FIG. 10a illustrates a back lighting system in accordance with the principles of the present disclosure.

[0033] FIG. 10b illustrates a back lighting system in accordance with the principles of the present disclosure.

[0034] FIGS. 11a to 11d illustrate light source and filters in accordance with the principles of the present disclosure.

[0035] FIGS. 12a to 12c illustrate light source and quantum dot systems in accordance with the principles of the present disclosure.

[0036] FIGS. 13a to 13c illustrate peripheral lighting systems in accordance with the principles of the present disclosure.

[0037] FIGS. 14a to 14c illustrate a light suppression systems in accordance with the principles of the present disclosure.

[0038] FIG. 15 illustrates an external user interface in accordance with the principles of the present disclosure.

[0039] FIGS. 16a to 16c illustrate distance control systems in accordance with the principles of the present disclosure.

[0040] FIGS. 17a to 17c illustrate force interpretation systems in accordance with the principles of the present disclosure.

[0041] FIGS. 18a to 18c illustrate user interface mode selection systems in accordance with the principles of the present disclosure.

[0042] FIG. 19 illustrates interaction systems in accordance with the principles of the present disclosure.

[0043] FIG. 20 illustrates external user interfaces in accordance with the principles of the present disclosure.

[0044] FIG. 21 illustrates mD trace representations presented in accordance with the principles of the present disclosure.

[0045] FIG. 22 illustrates mD trace representations presented in accordance with the principles of the present disclosure.

[0046] FIG. 23 illustrates an mD scanned environment in accordance with the principles of the present disclosure.

[0047] FIG. 23a illustrates mD trace representations presented in accordance with the principles of the present disclosure.

[0048] FIG. 24 illustrates a stray light suppression technology in accordance with the principles of the present disclosure.

[0049] FIG. 25 illustrates a stray light suppression technology in accordance with the principles of the present disclosure.

[0050] FIG. 26 illustrates a stray light suppression technology in accordance with the principles of the present disclosure.

[0051] FIG. 27 illustrates a stray light suppression technology in accordance with the principles of the present disclosure.

[0052] FIGS. 28a to 28c illustrate DLP mirror angles.

[0053] FIG. 29, FIG. 30, FIG. 31, FIG. 32, FIG. 32a, and FIG. 33 illustrate eye imaging systems according to the principles of the present disclosure.

[0054] FIGS. 34 and 34a illustrate structured eye lighting systems according to the principles of the present disclosure.

[0055] FIG. 35 illustrates eye glint in the prediction of eye direction analysis in accordance with the principles of the present disclosure.

[0056] FIG. 36a illustrates eye characteristics that may be used in personal identification through analysis of a system according to the principles of the present disclosure.

[0057] FIG. 36b illustrates a digital content presentation reflection off of the wearer's eye that may be analyzed in accordance with the principles of the present disclosure.

[0058] FIG. 37 illustrates eye imaging along various virtual target lines and various focal planes in accordance with the principles of the present disclosure.

[0059] FIG. 38 illustrates content control with respect to eye movement based on eye imaging in accordance with the principles of the present disclosure.

[0060] FIG. 39 illustrates eye imaging and eye convergence in accordance with the principles of the present disclosure.

[0061] FIG. 40 illustrates content position dependent on sensor feedback in accordance with the principles of the present disclosure.

[0062] FIG. 41 illustrates content position dependent on sensor feedback in accordance with the principles of the present disclosure.

[0063] FIG. 42 illustrates content position dependent on sensor feedback in accordance with the principles of the present disclosure.

[0064] FIG. 43 illustrates content position dependent on sensor feedback in accordance with the principles of the present disclosure.

[0065] FIG. 44 illustrates content position dependent on sensor feedback in accordance with the principles of the present disclosure.

[0066] FIG. 45 illustrates various headings over time in an example.

[0067] FIG. 46 illustrates content position dependent on sensor feedback in accordance with the principles of the present disclosure.

[0068] FIG. 47 illustrates content position dependent on sensor feedback in accordance with the principles of the present disclosure.

[0069] FIG. 48 illustrates content position dependent on sensor feedback in accordance with the principles of the present disclosure.

[0070] FIG. 49 illustrates content position dependent on sensor feedback in accordance with the principles of the present disclosure.

[0071] FIG. 50 illustrates a scene where a person is walking with a HWC mounted on his head.

[0072] FIG. 51 illustrates a system for receiving, developing and using movement heading, sight heading, eye heading and/or persistence information from HWC(s).

[0073] FIG. 52 illustrates a scene where a person is collecting other people's eye/sight headings.

[0074] FIG. 53 illustrates an optical configuration for a see-through head-worn computer display in accordance with the principles of the present disclosure.

[0075] FIG. 54 illustrates an optical configuration for a see-through head-worn computer display in accordance with the principles of the present disclosure.

[0076] FIG. 55 illustrates an optical configuration for a see-through head-worn computer display in accordance with the principles of the present disclosure.

[0077] FIG. 56 illustrates an optical configuration for a see-through head-worn computer display in accordance with the principles of the present disclosure.

[0078] FIG. 57 illustrates an optical configuration for a see-through head-worn computer display in accordance with the principles of the present disclosure.

[0079] While the disclosure has been described in connection with certain preferred embodiments, other embodiments would be understood by one of ordinary skill in the art and are encompassed herein.

DETAILED DESCRIPTION OF THE PREFERRED EMBODIMENT(S)

[0080] Aspects of the present disclosure relate to head-worn computing (“HWC”) systems. HWC involves, in some instances, a system that mimics the appearance of head-worn glasses or sunglasses. The glasses may be a fully developed computing platform, such as including computer displays presented in each of the lenses of the glasses to the eyes of the user. In embodiments, the lenses and displays may be configured to allow a person wearing the glasses to see the environment through the lenses while also seeing, simultaneously, digital imagery, which forms an overlaid image that is perceived by the person as a digitally augmented image of the environment, or augmented reality (“AR”).

[0081] HWC involves more than just placing a computing system on a person’s head. The system may need to be designed as a lightweight, compact and fully functional computer display, such as wherein the computer display includes a high resolution digital display that provides a high level of emersion comprised of the displayed digital content and the see-through view of the environmental surroundings. User interfaces and control systems suited to the HWC device may be required that are unlike those used for a more conventional computer such as a laptop. For the HWC and associated systems to be most effective, the glasses may be equipped with sensors to determine environmental conditions, geographic location, relative positioning to other points of interest, objects identified by imaging and movement by the user or other users in a connected group, and the like. The HWC may then change the mode of operation to match the conditions, location, positioning, movements, and the like, in a method generally referred to as a contextually aware HWC. The glasses also may need to be connected, wirelessly or otherwise, to other systems either locally or through a network. Controlling the glasses may be achieved through the use of an external device, automatically through contextually gathered information, through user gestures captured by the glasses sensors, and the like. Each technique may be further refined depending on the software application being used in the glasses. The glasses may further be used to control or coordinate with external devices that are associated with the glasses.

[0082] Referring to FIG. 1, an overview of the HWC system 100 is presented. As shown, the HWC system 100 comprises a HWC 102, which in this instance is configured as glasses to be worn on the head with sensors such that the HWC 102 is aware of the objects and conditions in the environment 114. In this instance, the HWC 102 also receives and interprets control inputs such as gestures and movements 116. The HWC 102 may communicate with external user interfaces 104. The external user interfaces 104 may provide a physical user interface to take control instructions from a user of the HWC 102 and the external user interfaces 104 and the HWC 102 may communicate bi-directionally to affect the user’s command and provide feedback to the external device 108. The HWC 102 may also communicate bi-directionally with externally controlled or coordinated local devices 108. For example, an external user interface 104 may be used in connection with the HWC 102

to control an externally controlled or coordinated local device 108. The externally controlled or coordinated local device 108 may provide feedback to the HWC 102 and a customized GUI may be presented in the HWC 102 based on the type of device or specifically identified device 108. The HWC 102 may also interact with remote devices and information sources 112 through a network connection 110. Again, the external user interface 104 may be used in connection with the HWC 102 to control or otherwise interact with any of the remote devices 108 and information sources 112 in a similar way as when the external user interfaces 104 are used to control or otherwise interact with the externally controlled or coordinated local devices 108. Similarly, HWC 102 may interpret gestures 116 (e.g. captured from forward, downward, upward, rearward facing sensors such as camera(s), range finders, IR sensors, etc.) or environmental conditions sensed in the environment 114 to control either local or remote devices 108 or 112.

[0083] We will now describe each of the main elements depicted on FIG. 1 in more detail; however, these descriptions are intended to provide general guidance and should not be construed as limiting. Additional description of each element may also be further described herein.

[0084] The HWC 102 is a computing platform intended to be worn on a person’s head. The HWC 102 may take many different forms to fit many different functional requirements. In some situations, the HWC 102 will be designed in the form of conventional glasses. The glasses may or may not have active computer graphics displays. In situations where the HWC 102 has integrated computer displays the displays may be configured as see-through displays such that the digital imagery can be overlaid with respect to the user’s view of the environment 114. There are a number of see-through optical designs that may be used, including ones that have a reflective display (e.g. LCoS, DLP), emissive displays (e.g. OLED, LED), hologram, TIR waveguides, and the like. In embodiments, lighting systems used in connection with the display optics may be solid state lighting systems, such as LED, OLED, quantum dot, quantum dot LED, etc. In addition, the optical configuration may be monocular or binocular. It may also include vision corrective optical components. In embodiments, the optics may be packaged as contact lenses. In other embodiments, the HWC 102 may be in the form of a helmet with a see-through shield, sunglasses, safety glasses, goggles, a mask, fire helmet with see-through shield, police helmet with see through shield, military helmet with see-through shield, utility form customized to a certain work task (e.g. inventory control, logistics, repair, maintenance, etc.), and the like.

[0085] The HWC 102 may also have a number of integrated computing facilities, such as an integrated processor, integrated power management, communication structures (e.g. cell net, WiFi, Bluetooth, local area connections, mesh connections, remote connections (e.g. client server, etc.)), and the like. The HWC 102 may also have a number of positional awareness sensors, such as GPS, electronic compass, altimeter, tilt sensor, IMU, and the like. It may also have other sensors such as a camera, rangefinder, hyperspectral camera, Geiger counter, microphone, spectral illumination detector, temperature sensor, chemical sensor, biologic sensor, moisture sensor, ultrasonic sensor, and the like.

[0086] The HWC 102 may also have integrated control technologies. The integrated control technologies may be contextual based control, passive control, active control,

user control, and the like. For example, the HWC 102 may have an integrated sensor (e.g. camera) that captures user hand or body gestures 116 such that the integrated processing system can interpret the gestures and generate control commands for the HWC 102. In another example, the HWC 102 may have sensors that detect movement (e.g. a nod, head shake, and the like) including accelerometers, gyros and other inertial measurements, where the integrated processor may interpret the movement and generate a control command in response. The HWC 102 may also automatically control itself based on measured or perceived environmental conditions. For example, if it is bright in the environment the HWC 102 may increase the brightness or contrast of the displayed image. In embodiments, the integrated control technologies may be mounted on the HWC 102 such that a user can interact with it directly. For example, the HWC 102 may have a button(s), touch capacitive interface, and the like.

[0087] As described herein, the HWC 102 may be in communication with external user interfaces 104. The external user interfaces may come in many different forms. For example, a cell phone screen may be adapted to take user input for control of an aspect of the HWC 102. The external user interface may be a dedicated UI, such as a keyboard, touch surface, button(s), joy stick, and the like. In embodiments, the external controller may be integrated into another device such as a ring, watch, bike, car, and the like. In each case, the external user interface 104 may include sensors (e.g. IMU, accelerometers, compass, altimeter, and the like) to provide additional input for controlling the HWD 104.

[0088] As described herein, the HWC 102 may control or coordinate with other local devices 108. The external devices 108 may be an audio device, visual device, vehicle, cell phone, computer, and the like. For instance, the local external device 108 may be another HWC 102, where information may then be exchanged between the separate HWCs 108.

[0089] Similar to the way the HWC 102 may control or coordinate with local devices 106, the HWC 102 may control or coordinate with remote devices 112, such as the HWC 102 communicating with the remote devices 112 through a network 110. Again, the form of the remote device 112 may have many forms. Included in these forms is another HWC 102. For example, each HWC 102 may communicate its GPS position such that all the HWCs 102 know where all of HWC 102 are located.

[0090] FIG. 2 illustrates a HWC 102 with an optical system that includes an upper optical module 202 and a lower optical module 204. While the upper and lower optical modules 202 and 204 will generally be described as separate modules, it should be understood that this is illustrative only and the present disclosure includes other physical configurations, such as that when the two modules are combined into a single module or where the elements making up the two modules are configured into more than two modules. In embodiments, the upper module 202 includes a computer controlled display (e.g. LCoS, DLP, OLED, etc.) and image light delivery optics. In embodiments, the lower module includes eye delivery optics that are configured to receive the upper module's image light and deliver the image light to the eye of a wearer of the HWC. In FIG. 2, it should be noted that while the upper and lower optical modules 202 and 204 are illustrated in one side of the HWC such that image light can be delivered to one eye of the wearer, that

it is envisioned by the present disclosure that embodiments will contain two image light delivery systems, one for each eye.

[0091] FIG. 3b illustrates an upper optical module 202 in accordance with the principles of the present disclosure. In this embodiment, the upper optical module 202 includes a DLP (also known as DMD or digital micromirror device) computer operated display 304 which includes pixels comprised of rotatable mirrors (such as, for example, the DLP3000 available from Texas Instruments), polarized light source 302, ¼ wave retarder film 308, reflective polarizer 310 and a field lens 312. The polarized light source 302 provides substantially uniform polarized light that is generally directed towards the reflective polarizer 310. The reflective polarizer reflects light of one polarization state (e.g. S polarized light) and transmits light of the other polarization state (e.g. P polarized light). The polarized light source 302 and the reflective polarizer 310 are oriented so that the polarized light from the polarized light source 302 is reflected generally towards the DLP 304. The light then passes through the ¼ wave film 308 once before illuminating the pixels of the DLP 304 and then again after being reflected by the pixels of the DLP 304. In passing through the ¼ wave film 308 twice, the light is converted from one polarization state to the other polarization state (e.g. the light is converted from S to P polarized light). The light then passes through the reflective polarizer 310. In the event that the DLP pixel(s) are in the "on" state (i.e. the mirrors are positioned to reflect light towards the field lens 312, the "on" pixels reflect the light generally along the optical axis and into the field lens 312. This light that is reflected by "on" pixels and which is directed generally along the optical axis of the field lens 312 will be referred to as image light 316. The image light 316 then passes through the field lens to be used by a lower optical module 204.

[0092] The light that is provided by the polarized light source 302, which is subsequently reflected by the reflective polarizer 310 before it reflects from the DLP 304, will generally be referred to as illumination light. The light that is reflected by the "off" pixels of the DLP 304 is reflected at a different angle than the light reflected by the "on" pixels, so that the light from the "off" pixels is generally directed away from the optical axis of the field lens 312 and toward the side of the upper optical module 202 as shown in FIG. 3. The light that is reflected by the "off" pixels of the DLP 304 will be referred to as dark state light 314.

[0093] The DLP 304 operates as a computer controlled display and is generally thought of as a MEMs device. The DLP pixels are comprised of small mirrors that can be directed. The mirrors generally flip from one angle to another angle. The two angles are generally referred to as states. When light is used to illuminate the DLP the mirrors will reflect the light in a direction depending on the state. In embodiments herein, we generally refer to the two states as "on" and "off," which is intended to depict the condition of a display pixel. "On" pixels will be seen by a viewer of the display as emitting light because the light is directed along the optical axis and into the field lens and the associated remainder of the display system. "Off" pixels will be seen by a viewer of the display as not emitting light because the light from these pixels is directed to the side of the optical housing and into a light trap or light dump where the light is absorbed. The pattern of "on" and "off" pixels produces image light that is perceived by a viewer of the display as a

computer generated image. Full color images can be presented to a user by sequentially providing illumination light with complimentary colors such as red, green and blue. Where the sequence is presented in a recurring cycle that is faster than the user can perceive as separate images and as a result the user perceives a full color image comprised of the sum of the sequential images. Bright pixels in the image are provided by pixels that remain in the “on” state for the entire time of the cycle, while dimmer pixels in the image are provided by pixels that switch between the “on” state and “off” state within the time of the cycle, or frame time when in a video sequence of images.

[0094] FIG. 3a shows an illustration of a system for a DLP 304 in which the unpolarized light source 350 is pointed directly at the DLP 304. In this case, the angle required for the illumination light is such that the field lens 352 must be positioned substantially distant from the DLP 304 to avoid the illumination light from being clipped by the field lens 352. The large distance between the field lens 352 and the DLP 304 along with the straight path of the dark state light 354, means that the light trap for the dark state light 354 is also located at a substantial distance from the DLP. For these reasons, this configuration is larger in size compared to the upper optics module 202 of the preferred embodiments.

[0095] The configuration illustrated in FIG. 3b can be lightweight and compact such that it fits into a small portion of a HWC. For example, the upper modules 202 illustrated herein can be physically adapted to mount in an upper frame of a HWC such that the image light can be directed into a lower optical module 204 for presentation of digital content to a wearer’s eye. The package of components that combine to generate the image light (i.e. the polarized light source 302, DLP 304, reflective polarizer 310 and ¼ wave film 308) is very light and is compact. The height of the system, excluding the field lens, may be less than 8 mm. The width (i.e. from front to back) may be less than 8 mm. The weight may be less than 2 grams. The compactness of this upper optical module 202 allows for a compact mechanical design of the HWC and the light weight nature of these embodiments help make the HWC lightweight to provide for a HWC that is comfortable for a wearer of the HWC.

[0096] The configuration illustrated in FIG. 3b can produce sharp contrast, high brightness and deep blacks, especially when compared to LCD or LCoS displays used in HWC. The “on” and “off” states of the DLP provide for a strong differentiator in the light reflection path representing an “on” pixel and an “off” pixel. As will be discussed in more detail below, the dark state light from the “off” pixel reflections can be managed to reduce stray light in the display system to produce images with high contrast.

[0097] FIG. 4 illustrates another embodiment of an upper optical module 202 in accordance with the principles of the present disclosure. This embodiment includes a light source 404, but in this case, the light source can provide unpolarized illumination light. The illumination light from the light source 404 is directed into a TIR wedge 418 such that the illumination light is incident on an internal surface of the TIR wedge 418 (shown as the angled lower surface of the TRI wedge 418 in FIG. 4) at an angle that is beyond the critical angle as defined by Eqn 1.

$$\text{Critical angle} = \arcsin(1/n)$$

Eqn 1

[0098] Where the critical angle is the angle beyond which the illumination light is reflected from the internal surface

when the internal surface comprises an interface from a solid with a higher refractive index (n) to air with a refractive index of 1 (e.g. for an interface of acrylic, with a refractive index of n=1.5, to air, the critical angle is 41.8 degrees; for an interface of polycarbonate, with a refractive index of n=1.59, to air the critical angle is 38.9 degrees). Consequently, the TIR wedge 418 is associated with a thin air gap 408 along the internal surface to create an interface between a solid with a higher refractive index and air. By choosing the angle of the light source 404 relative to the DLP 402 in correspondence to the angle of the internal surface of the TIR wedge 418, illumination light is turned toward the DLP 402 at an angle suitable for providing image light 414 as reflected from “on” pixels. Wherein, the illumination light is provided to the DLP 402 at approximately twice the angle of the pixel mirrors in the DLP 402 that are in the “on” state, such that after reflecting from the pixel mirrors, the image light 414 is directed generally along the optical axis of the field lens. Depending on the state of the DLP pixels, the illumination light from “on” pixels may be reflected as image light 414 which is directed towards a field lens and a lower optical module 204, while illumination light reflected from “off” pixels (generally referred to herein as “dark” state light, “off” pixel light or “off” state light) 410 is directed in a separate direction, which may be trapped and not used for the image that is ultimately presented to the wearer’s eye.

[0099] The light trap for the dark state light 410 may be located along the optical axis defined by the direction of the dark state light 410 and in the side of the housing, with the function of absorbing the dark state light. To this end, the light trap may be comprised of an area outside of the cone of image light 414 from the “on” pixels. The light trap is typically made up of materials that absorb light including coatings of black paints or other light absorbing materials to prevent light scattering from the dark state light degrading the image perceived by the user. In addition, the light trap may be recessed into the wall of the housing or include masks or guards to block scattered light and prevent the light trap from being viewed adjacent to the displayed image.

[0100] The embodiment of FIG. 4 also includes a corrective wedge 420 to correct the effect of refraction of the image light 414 as it exits the TIR wedge 418. By including the corrective wedge 420 and providing a thin air gap 408 (e.g. 25 micron), the image light from the “on” pixels can be maintained generally in a direction along the optical axis of the field lens (i.e. the same direction as that defined by the image light 414) so it passes into the field lens and the lower optical module 204. As shown in FIG. 4, the image light 414 from the “on” pixels exits the corrective wedge 420 generally perpendicular to the surface of the corrective wedge 420 while the dark state light exits at an oblique angle. As a result, the direction of the image light 414 from the “on” pixels is largely unaffected by refraction as it exits from the surface of the corrective wedge 420. In contrast, the dark state light 410 is substantially changed in direction by refraction when the dark state light 410 exits the corrective wedge 420.

[0101] The embodiment illustrated in FIG. 4 has the similar advantages of those discussed in connection with the embodiment of FIG. 3b. The dimensions and weight of the upper module 202 depicted in FIG. 4 may be approximately 8x8 mm with a weight of less than 3 grams. A difference in overall performance between the configuration illustrated in FIGS. 3b and the configuration illustrated in FIG. 4 is that

the embodiment of FIG. 4 doesn't require the use of polarized light as supplied by the light source 404. This can be an advantage in some situations as will be discussed in more detail below (e.g. increased see-through transparency of the HWC optics from the user's perspective). Polarized light may be used in connection with the embodiment depicted in FIG. 4, in embodiments. An additional advantage of the embodiment of FIG. 4 compared to the embodiment shown in FIG. 3b is that the dark state light (shown as DLP off light 410) is directed at a steeper angle away from the optical axis of the image light 414 due to the added refraction encountered when the dark state light 410 exits the corrective wedge 420. This steeper angle of the dark state light 410 allows for the light trap to be positioned closer to the DLP 402 so that the overall size of the upper module 202 can be reduced. The light trap can also be made larger since the light trap doesn't interfere with the field lens, thereby the efficiency of the light trap can be increased and as a result, stray light can be reduced and the contrast of the image perceived by the user can be increased. FIG. 4a illustrates the embodiment described in connection with FIG. 4 with an example set of corresponding angles at the various surfaces with the reflected angles of a ray of light passing through the upper optical module 202. In this example, the DLP mirrors are provided at 17 degrees to the surface of the DLP device. The angles of the TIR wedge are selected in correspondence to one another to provide TIR reflected illumination light at the correct angle for the DLP mirrors while allowing the image light and dark state light to pass through the thin air gap, various combinations of angles are possible to achieve this.

[0102] FIG. 5 illustrates yet another embodiment of an upper optical module 202 in accordance with the principles of the present disclosure. As with the embodiment shown in FIG. 4, the embodiment shown in FIG. 5 does not require the use of polarized light. Polarized light may be used in connection with this embodiment, but it is not required. The optical module 202 depicted in FIG. 5 is similar to that presented in connection with FIG. 4; however, the embodiment of FIG. 5 includes an off light redirection wedge 502. As can be seen from the illustration, the off light redirection wedge 502 allows the image light 414 to continue generally along the optical axis toward the field lens and into the lower optical module 204 (as illustrated). However, the off light 504 is redirected substantially toward the side of the corrective wedge 420 where it passes into the light trap. This configuration may allow further height compactness in the HWC because the light trap (not illustrated) that is intended to absorb the off light 504 can be positioned laterally adjacent the upper optical module 202 as opposed to below it. In the embodiment depicted in FIG. 5 there is a thin air gap between the TIR wedge 418 and the corrective wedge 420 (similar to the embodiment of FIG. 4). There is also a thin air gap between the corrective wedge 420 and the off light redirection wedge 502. There may be HWC mechanical configurations that warrant the positioning of a light trap for the dark state light elsewhere and the illustration depicted in FIG. 5 should be considered illustrative of the concept that the off light can be redirected to create compactness of the overall HWC. FIG. 5a illustrates an example of the embodiment described in connection with FIG. 5 with the addition of more details on the relative angles at the various surfaces and a light ray trace for image light and a light ray trace for

dark light are shown as it passes through the upper optical module 202. Again, various combinations of angles are possible.

[0103] FIG. 4b shows an illustration of a further embodiment in which a solid transparent matched set of wedges 456 is provided with a reflective polarizer 450 at the interface between the wedges. Wherein the interface between the wedges in the wedge set 456 is provided at an angle so that illumination light 452 from the polarized light source 458 is reflected at the proper angle (e.g. 34 degrees for a 17 degree DLP mirror) for the DLP mirror "on" state so that the reflected image light 414 is provided along the optical axis of the field lens. The general geometry of the wedges in the wedge set 456 is similar to that shown in FIGS. 4 and 4a. A quarter wave film 454 is provided on the DLP 402 surface so that the illumination light 452 is one polarization state (e.g. S polarization state) while in passing through the quarter wave film 454, reflecting from the DLP mirror and passing back through the quarter wave film 454, the image light 414 is converted to the other polarization state (e.g. P polarization state). The reflective polarizer is oriented such that the illumination light 452 with its polarization state is reflected and the image light 414 with its other polarization state is transmitted. Since the dark state light from the "off" pixels 410 also passes through the quarter wave film 454 twice, it is also the other polarization state (e.g. P polarization state) so that it is transmitted by the reflective polarizer 450.

[0104] The angles of the faces of the wedge set 450 correspond to the needed angles to provide illumination light 452 at the angle needed by the DLP mirrors when in the "on" state so that the reflected image light 414 is reflected from the DLP along the optical axis of the field lens. The wedge set 456 provides an interior interface where a reflective polarizer film can be located to redirect the illumination light 452 toward the mirrors of the DLP 402. The wedge set also provides a matched wedge on the opposite side of the reflective polarizer 450 so that the image light 414 from the "on" pixels exits the wedge set 450 substantially perpendicular to the exit surface, while the dark state light from the "off" pixels 410 exits at an oblique angle to the exit surface. As a result, the image light 414 is substantially unrefracted upon exiting the wedge set 456, while the dark state light from the "off" pixels 410 is substantially refracted upon exiting the wedge set 456 as shown in FIG. 4b.

[0105] By providing a solid transparent matched wedge set, the flatness of the interface is reduced, because variations in the flatness have a negligible effect as long as they are within the cone angle of the illuminating light 452. Which can be f#2.2 with a 26 degree cone angle. In a preferred embodiment, the reflective polarizer is bonded between the matched internal surfaces of the wedge set 456 using an optical adhesive so that Fresnel reflections at the interfaces on either side of the reflective polarizer 450 are reduced. The optical adhesive can be matched in refractive index to the material of the wedge set 456 and the pieces of the wedge set 456 can be all made from the same material such as BK7 glass or cast acrylic. Wherein the wedge material can be selected to have low birefringence as well to reduce non-uniformities in brightness. The wedge set 456 and the quarter wave film 454 can also be bonded to the DLP 402 to further reduce Fresnel reflections at the DLP interface losses. In addition, since the image light 414 is substantially normal to the exit surface of the wedge set 456, the flatness

of the surface is not critical to maintain the wavefront of the image light **414** so that high image quality can be obtained in the displayed image without requiring very tightly tolerated flatness on the exit surface.

[0106] A yet further embodiment of the disclosure that is not illustrated, combines the embodiments illustrated in FIG. **4b** and FIG. **5**. In this embodiment, the wedge set **456** is comprised of three wedges with the general geometry of the wedges in the wedge set corresponding to that shown in FIGS. **5** and **5a**. A reflective polarizer is bonded between the first and second wedges similar to that shown in FIG. **4b**, however, a third wedge is provided similar to the embodiment of FIG. **5**. Wherein there is an angled thin air gap between the second and third wedges so that the dark state light is reflected by TIR toward the side of the second wedge where it is absorbed in a light trap. This embodiment, like the embodiment shown in FIG. **4b**, uses a polarized light source as has been previously described. The difference in this embodiment is that the image light is transmitted through the reflective polarizer and is transmitted through the angled thin air gap so that it exits normal to the exit surface of the third wedge.

[0107] FIG. **5b** illustrates an upper optical module **202** with a dark light trap **514a**. As described in connection with FIGS. **4** and **4a**, image light can be generated from a DLP when using a TIR and corrective lens configuration. The upper module may be mounted in a HWC housing **510** and the housing **510** may include a dark light trap **514a**. The dark light trap **514a** is generally positioned/constructed/formed in a position that is optically aligned with the dark light optical axis **512**. As illustrated, the dark light trap may have depth such that the trap internally reflects dark light in an attempt to further absorb the light and prevent the dark light from combining with the image light that passes through the field lens. The dark light trap may be of a shape and depth such that it absorbs the dark light. In addition, the dark light trap **514b**, in embodiments, may be made of light absorbing materials or coated with light absorbing materials. In embodiments, the recessed light trap **514a** may include baffles to block a view of the dark state light. This may be combined with black surfaces and textured or fibrous surfaces to help absorb the light. The baffles can be part of the light trap, associated with the housing, or field lens, etc.

[0108] FIG. **5c** illustrates another embodiment with a light trap **514b**. As can be seen in the illustration, the shape of the trap is configured to enhance internal reflections within the light trap **514b** to increase the absorption of the dark light **512**. FIG. **5d** illustrates another embodiment with a light trap **514c**. As can be seen in the illustration, the shape of the trap **514c** is configured to enhance internal reflections to increase the absorption of the dark light **512**.

[0109] FIG. **5e** illustrates another embodiment of an upper optical module **202** with a dark light trap **514d**. This embodiment of upper module **202** includes an off light reflection wedge **502**, as illustrated and described in connection with the embodiment of FIGS. **5** and **5a**. As can be seen in FIG. **5e**, the light trap **514d** is positioned along the optical path of the dark light **512**. The dark light trap **514d** may be configured as described in other embodiments herein. The embodiment of the light trap **514d** illustrated in figure **5e** includes a black area on the side wall of the wedge, wherein the side wall is located substantially away from the optical axis of the image light **414**. In addition, baffles **5252** may be added to one or more edges of the field lens **312** to

block the view of the light trap **514d** adjacent to the displayed image seen by the user.

[0110] FIG. **6** illustrates a combination of an upper optical module **202** with a lower optical module **204**. In this embodiment, the image light projected from the upper optical module **202** may or may not be polarized. The image light is reflected off a flat combiner element **602** such that it is directed towards the user's eye. Wherein, the combiner element **602** is a partial mirror that reflects image light while transmitting a substantial portion of light from the environment so the user can look through the combiner element and see the environment surrounding the HWC.

[0111] The combiner **602** may include a holographic pattern, to form a holographic mirror. If a monochrome image is desired, there may be a single wavelength reflection design for the holographic pattern on the surface of the combiner **602**. If the intention is to have multiple colors reflected from the surface of the combiner **602**, a multiple wavelength holographic mirror maybe included on the combiner surface. For example, in a three-color embodiment, where red, green and blue pixels are generated in the image light, the holographic mirror may be reflective to wavelengths substantially matching the wavelengths of the red, green and blue light provided by the light source. This configuration can be used as a wavelength specific mirror where pre-determined wavelengths of light from the image light are reflected to the user's eye. This configuration may also be made such that substantially all other wavelengths in the visible pass through the combiner element **602** so the user has a substantially clear view of the surroundings when looking through the combiner element **602**. The transparency between the user's eye and the surrounding may be approximately 80% when using a combiner that is a holographic mirror. Wherein holographic mirrors can be made using lasers to produce interference patterns in the holographic material of the combiner where the wavelengths of the lasers correspond to the wavelengths of light that are subsequently reflected by the holographic mirror.

[0112] In another embodiment, the combiner element **602** may include a notch mirror comprised of a multilayer coated substrate wherein the coating is designed to substantially reflect the wavelengths of light provided by the light source and substantially transmit the remaining wavelengths in the visible spectrum. For example, in the case where red, green and blue light is provided by the light source to enable full color images to be provided to the user, the notch mirror is a tristimulus notch mirror wherein the multilayer coating is designed to reflect narrow bands of red, green and blue light that are matched to the what is provided by the light source and the remaining visible wavelengths are transmitted through the coating to enable a view of the environment through the combiner. In another example where monochrome images are provided to the user, the notch mirror is designed to reflect a single narrow band of light that is matched to the wavelength range of the light provided by the light source while transmitting the remaining visible wavelengths to enable a see-thru view of the environment. The combiner **602** with the notch mirror would operate, from the user's perspective, in a manner similar to the combiner that includes a holographic pattern on the combiner element **602**. The combiner, with the tristimulus notch mirror, would reflect the "on" pixels to the eye because of the match between the reflective wavelengths of the notch mirror and the color of the image light, and the wearer would be able

to see with high clarity the surroundings. The transparency between the user's eye and the surrounding may be approximately 80% when using the tristimulus notch mirror. In addition, the image provided by the upper optical module 202 with the notch mirror combiner can provide higher contrast images than the holographic mirror combiner due to less scattering of the imaging light by the combiner.

[0113] Light can escape through the combiner 602 and may produce face glow as the light is generally directed downward onto the cheek of the user. When using a holographic mirror combiner or a tristimulus notch mirror combiner, the escaping light can be trapped to avoid face glow. In embodiments, if the image light is polarized before the combiner, a linear polarizer can be laminated, or otherwise associated, to the combiner, with the transmission axis of the polarizer oriented relative to the polarized image light so that any escaping image light is absorbed by the polarizer. In embodiments, the image light would be polarized to provide S polarized light to the combiner for better reflection. As a result, the linear polarizer on the combiner would be oriented to absorb S polarized light and pass P polarized light. This provides the preferred orientation of polarized sunglasses as well.

[0114] If the image light is unpolarized, a microlouvered film such as a privacy filter can be used to absorb the escaping image light while providing the user with a see-thru view of the environment. In this case, the absorbance or transmittance of the microlouvered film is dependent on the angle of the light. Where steep angle light is absorbed and light at less of an angle is transmitted. For this reason, in an embodiment, the combiner with the microlouver film is angled at greater than 45 degrees to the optical axis of the image light (e.g. the combiner can be oriented at 50 degrees so the image light from the file lens is incident on the combiner at an oblique angle).

[0115] FIG. 7 illustrates an embodiment of a combiner element 602 at various angles when the combiner element 602 includes a holographic mirror. Normally, a mirrored surface reflects light at an angle equal to the angle that the light is incident to the mirrored surface. Typically, this necessitates that the combiner element be at 45 degrees, 602a, if the light is presented vertically to the combiner so the light can be reflected horizontally towards the wearer's eye. In embodiments, the incident light can be presented at angles other than vertical to enable the mirror surface to be oriented at other than 45 degrees, but in all cases wherein a mirrored surface is employed (including the tristimulus notch mirror described previously), the incident angle equals the reflected angle. As a result, increasing the angle of the combiner 602a requires that the incident image light be presented to the combiner 602a at a different angle which positions the upper optical module 202 to the left of the combiner as shown in FIG. 7. In contrast, a holographic mirror combiner, included in embodiments, can be made such that light is reflected at a different angle from the angle that the light is incident onto the holographic mirrored surface. This allows freedom to select the angle of the combiner element 602b independent of the angle of the incident image light and the angle of the light reflected into the wearer's eye. In embodiments, the angle of the combiner element 602b is greater than 45 degrees (shown in FIG. 7) as this allows a more laterally compact HWC design. The increased angle of the combiner element 602b decreases the front to back width of the lower optical module 204 and may

allow for a thinner HWC display (i.e. the furthest element from the wearer's eye can be closer to the wearer's face).

[0116] FIG. 8 illustrates another embodiment of a lower optical module 204. In this embodiment, polarized image light provided by the upper optical module 202, is directed into the lower optical module 204. The image light reflects off a polarized mirror 804 and is directed to a focusing partially reflective mirror 802, which is adapted to reflect the polarized light. An optical element such as a ¼ wave film located between the polarized mirror 804 and the partially reflective mirror 802, is used to change the polarization state of the image light such that the light reflected by the partially reflective mirror 802 is transmitted by the polarized mirror 804 to present image light to the eye of the wearer. The user can also see through the polarized mirror 804 and the partially reflective mirror 802 to see the surrounding environment. As a result, the user perceives a combined image comprised of the displayed image light overlaid onto the see-thru view of the environment.

[0117] While many of the embodiments of the present disclosure have been referred to as upper and lower modules containing certain optical components, it should be understood that the image light and dark light production and management functions described in connection with the upper module may be arranged to direct light in other directions (e.g. upward, sideward, etc.). In embodiments, it may be preferred to mount the upper module 202 above the wearer's eye, in which case the image light would be directed downward. In other embodiments it may be preferred to produce light from the side of the wearer's eye, or from below the wearer's eye. In addition, the lower optical module is generally configured to deliver the image light to the wearer's eye and allow the wearer to see through the lower optical module, which may be accomplished through a variety of optical components.

[0118] FIG. 8a illustrates an embodiment of the present disclosure where the upper optical module 202 is arranged to direct image light into a TIR waveguide 810. In this embodiment, the upper optical module 202 is positioned above the wearer's eye 812 and the light is directed horizontally into the TIR waveguide 810. The TIR waveguide is designed to internally reflect the image light in a series of downward TIR reflections until it reaches the portion in front of the wearer's eye, where the light passes out of the TIR waveguide 812 into the wearer's eye. In this embodiment, an outer shield 814 is positioned in front of the TIR waveguide 810.

[0119] FIG. 8b illustrates an embodiment of the present disclosure where the upper optical module 202 is arranged to direct image light into a TIR waveguide 818. In this embodiment, the upper optical module 202 is arranged on the side of the TIR waveguide 818. For example, the upper optical module may be positioned in the arm or near the arm of the HWC when configured as a pair of head worn glasses. The TIR waveguide 818 is designed to internally reflect the image light in a series of TIR reflections until it reaches the portion in front of the wearer's eye, where the light passes out of the TIR waveguide 812 into the wearer's eye.

[0120] FIG. 8c illustrates yet further embodiments of the present disclosure where an upper optical module 202 is directing polarized image light into an optical guide 828 where the image light passes through a polarized reflector 824, changes polarization state upon reflection of the optical element 822 which includes a ¼ wave film for example and

then is reflected by the polarized reflector **824** towards the wearer's eye, due to the change in polarization of the image light. The upper optical module **202** may be positioned to direct light to a mirror **820**, to position the upper optical module **202** laterally, in other embodiments, the upper optical module **202** may direct the image light directly towards the polarized reflector **824**. It should be understood that the present disclosure comprises other optical arrangements intended to direct image light into the wearer's eye.

[0121] Another aspect of the present disclosure relates to eye imaging. In embodiments, a camera is used in connection with an upper optical module **202** such that the wearer's eye can be imaged using pixels in the "off" state on the DLP. FIG. 9 illustrates a system where the eye imaging camera **802** is mounted and angled such that the field of view of the eye imaging camera **802** is redirected toward the wearer's eye by the mirror pixels of the DLP **402** that are in the "off" state. In this way, the eye imaging camera **802** can be used to image the wearer's eye along the same optical axis as the displayed image that is presented to the wearer. Wherein, image light that is presented to the wearer's eye illuminates the wearer's eye so that the eye can be imaged by the eye imaging camera **802**. In the process, the light reflected by the eye passes back through the optical train of the lower optical module **204** and a portion of the upper optical module to where the light is reflected by the "off" pixels of the DLP **402** toward the eye imaging camera **802**.

[0122] In embodiments, the eye imaging camera may image the wearer's eye at a moment in time where there are enough "off" pixels to achieve the required eye image resolution. In another embodiment, the eye imaging camera collects eye image information from "off" pixels over time and forms a time lapsed image. In another embodiment, a modified image is presented to the user wherein enough "off" state pixels are included that the camera can obtain the desired resolution and brightness for imaging the wearer's eye and the eye image capture is synchronized with the presentation of the modified image.

[0123] The eye imaging system may be used for security systems. The HWC may not allow access to the HWC or other system if the eye is not recognized (e.g. through eye characteristics including retina or iris characteristics, etc.). The HWC may be used to provide constant security access in some embodiments. For example, the eye security confirmation may be a continuous, near-continuous, real-time, quasi real-time, periodic, etc. process so the wearer is effectively constantly being verified as known. In embodiments, the HWC may be worn and eye security tracked for access to other computer systems.

[0124] The eye imaging system may be used for control of the HWC. For example, a blink, wink, or particular eye movement may be used as a control mechanism for a software application operating on the HWC or associated device.

[0125] The eye imaging system may be used in a process that determines how or when the HWC **102** delivers digitally displayed content to the wearer. For example, the eye imaging system may determine that the user is looking in a direction and then HWC may change the resolution in an area of the display or provide some content that is associated with something in the environment that the user may be looking at. Alternatively, the eye imaging system may identify different user's and change the displayed content or enabled features provided to the user. User's may be iden-

tified from a database of users eye characteristics either located on the HWC **102** or remotely located on the network **110** or on a server **112**. In addition, the HWC may identify a primary user or a group of primary users from eye characteristics wherein the primary user(s) are provided with an enhanced set of features and all other users are provided with a different set of features. Thus in this use case, the HWC **102** uses identified eye characteristics to either enable features or not and eye characteristics need only be analyzed in comparison to a relatively small database of individual eye characteristics.

[0126] FIG. 10 illustrates a light source that may be used in association with the upper optics module **202** (e.g. polarized light source if the light from the solid state light source is polarized such as polarized light source **302** and **458**), and light source **404**. In embodiments, to provide a uniform surface of light **1008** to be directed into the upper optical module **202** and towards the DLP of the upper optical module, either directly or indirectly, the solid state light source **1002** may be projected into a backlighting optical system **1004**. The solid state light source **1002** may be one or more LEDs, laser diodes, OLEDs. In embodiments, the backlighting optical system **1004** includes an extended section with a length/distance ratio of greater than 3, wherein the light undergoes multiple reflections from the sidewalls to mix of homogenize the light as supplied by the solid state light source **1002**. The backlighting optical system **1004** can also include structures on the surface opposite (on the left side as shown in FIG. 10) to where the uniform light **1008** exits the backlight **1004** to change the direction of the light toward the DLP **302** and the reflective polarizer **310** or the DLP **402** and the TIR wedge **418**. The backlighting optical system **1004** may also include structures to collimate the uniform light **1008** to provide light to the DLP with a smaller angular distribution or narrower cone angle. Diffusers or polarizers can be used on the entrance or exit surface of the backlighting optical system. Diffusers can be used to spread or uniformize the exiting light from the backlight to improve the uniformity or increase the angular spread of the uniform light **1008**. Elliptical diffusers that diffuse the light more in some directions and less in others can be used to improve the uniformity or spread of the uniform light **1008** in directions orthogonal to the optical axis of the uniform light **1008**. Linear polarizers can be used to convert unpolarized light as supplied by the solid state light source **1002** to polarized light so the uniform light **1008** is polarized with a desired polarization state. A reflective polarizer can be used on the exit surface of the backlight **1004** to polarize the uniform light **1008** to the desired polarization state, while reflecting the other polarization state back into the backlight where it is recycled by multiple reflections within the backlight **1004** and at the solid state light source **1002**. Therefore by including a reflective polarizer at the exit surface of the backlight **1004**, the efficiency of the polarized light source is improved.

[0127] FIGS. 10a and 10b show illustrations of structures in backlight optical systems **1004** that can be used to change the direction of the light provided to the entrance face **1045** by the light source and then collimates the light in a direction lateral to the optical axis of the exiting uniform light **1008**. Structure **1060** includes an angled sawtooth pattern in a transparent waveguide wherein the left edge of each sawtooth clips the steep angle rays of light thereby limiting the angle of the light being redirected. The steep surface at the

right (as shown) of each sawtooth then redirects the light so that it reflects off the left angled surface of each sawtooth and is directed toward the exit surface **1040**. The sawtooth surfaces shown on the lower surface in FIGS. **10a** and **10b**, can be smooth and coated (e.g. with an aluminum coating or a dielectric mirror coating) to provide a high level of reflectivity without scattering. Structure **1050** includes a curved face on the left side (as shown) to focus the rays after they pass through the exit surface **1040**, thereby providing a mechanism for collimating the uniform light **1008**. In a further embodiment, a diffuser can be provided between the solid state light source **1002** and the entrance face **1045** to homogenize the light provided by the solid state light source **1002**. In yet a further embodiment, a polarizer can be used between the diffuser and the entrance face **1045** of the backlight **1004** to provide a polarized light source. Because the sawtooth pattern provides smooth reflective surfaces, the polarization state of the light can be preserved from the entrance face **1045** to the exit face **1040**. In this embodiment, the light entering the backlight from the solid state light source **1002** passes through the polarizer so that it is polarized with the desired polarization state. If the polarizer is an absorptive linear polarizer, the light of the desired polarization state is transmitted while the light of the other polarization state is absorbed. If the polarizer is a reflective polarizer, the light of the desired polarization state is transmitted into the backlight **1004** while the light of the other polarization state is reflected back into the solid state light source **1002** where it can be recycled as previously described, to increase the efficiency of the polarized light source.

[**0128**] FIG. **11a** illustrates a light source **1100** that may be used in association with the upper optics module **202**. In embodiments, the light source **1100** may provide light to a backlighting optical system **1004** as described above in connection with FIG. **10**. In embodiments, the light source **1100** includes a tristimulus notch filter **1102**. The tristimulus notch filter **1102** has narrow band pass filters for three wavelengths, as indicated in FIG. **11c** in a transmission graph **1108**. The graph shown in FIG. **11b**, as **1104** illustrates an output of three different colored LEDs. One can see that the bandwidths of emission are narrow, but they have long tails. The tristimulus notch filter **1102** can be used in connection with such LEDs to provide a light source **1100** that emits narrow filtered wavelengths of light as shown in FIG. **11d** as the transmission graph **1110**. Wherein the clipping effects of the tristimulus notch filter **1102** can be seen to have cut the tails from the LED emission graph **1104** to provide narrower wavelength bands of light to the upper optical module **202**. The light source **1100** can be used in connection with a combiner **602** with a holographic mirror or tristimulus notch mirror to provide narrow bands of light that are reflected toward the wearer's eye with less waste light that does not get reflected by the combiner, thereby improving efficiency and reducing escaping light that can cause faceglow.

[**0129**] FIG. **12a** illustrates another light source **1200** that may be used in association with the upper optics module **202**. In embodiments, the light source **1200** may provide light to a backlighting optical system **1004** as described above in connection with FIG. **10**. In embodiments, the light source **1200** includes a quantum dot cover glass **1202**. Where the quantum dots absorb light of a shorter wavelength and emit light of a longer wavelength (FIG. **12b**

shows an example wherein a UV spectrum **1202** applied to a quantum dot results in the quantum dot emitting a narrow band shown as a PL spectrum **1204**) that is dependent on the material makeup and size of the quantum dot. As a result, quantum dots in the quantum dot cover glass **1202** can be tailored to provide one or more bands of narrow bandwidth light (e.g. red, green and blue emissions dependent on the different quantum dots included as illustrated in the graph shown in FIG. **12c** where three different quantum dots are used. In embodiments, the LED driver light emits UV light, deep blue or blue light. For sequential illumination of different colors, multiple light sources **1200** would be used where each light source **1200** would include a quantum dot cover glass **1202** with a quantum dot selected to emit at one of the desired colors. The light source **1100** can be used in connection with a combiner **602** with a holographic mirror or tristimulus notch mirror to provide narrow transmission bands of light that are reflected toward the wearer's eye with less waste light that does not get reflected.

[**0130**] Another aspect of the present disclosure relates to the generation of peripheral image lighting effects for a person wearing a HWC. In embodiments, a solid state lighting system (e.g. LED, OLED, etc), or other lighting system, may be included inside the optical elements of an lower optical module **204**. The solid state lighting system may be arranged such that lighting effects outside of a field of view (FOV) of the presented digital content is presented to create an immersive effect for the person wearing the HWC. To this end, the lighting effects may be presented to any portion of the HWC that is visible to the wearer. The solid state lighting system may be digitally controlled by an integrated processor on the HWC. In embodiments, the integrated processor will control the lighting effects in coordination with digital content that is presented within the FOV of the HWC. For example, a movie, picture, game, or other content, may be displayed or playing within the FOV of the HWC. The content may show a bomb blast on the right side of the FOV and at the same moment, the solid state lighting system inside of the upper module optics may flash quickly in concert with the FOV image effect. The effect may not be fast, it may be more persistent to indicate, for example, a general glow or color on one side of the user. The solid state lighting system may be color controlled, with red, green and blue LEDs, for example, such that color control can be coordinated with the digitally presented content within the field of view.

[**0131**] FIG. **13a** illustrates optical components of a lower optical module **204** together with an outer lens **1302**. FIG. **13a** also shows an embodiment including effects LED's **1308a** and **1308b**. FIG. **13a** illustrates image light **1312**, as described herein elsewhere, directed into the upper optical module where it will reflect off of the combiner element **1304**, as described herein elsewhere. The combiner element **1304** in this embodiment is angled towards the wearer's eye at the top of the module and away from the wearer's eye at the bottom of the module, as also illustrated and described in connection with FIG. **8** (e.g. at a 45 degree angle). The image light **1312** provided by an upper optical module **202** (not shown in FIG. **13a**) reflects off of the combiner element **1304** towards the collimating mirror **1310**, away from the wearer's eye, as described herein elsewhere. The image light **1312** then reflects and focuses off of the collimating mirror **1304**, passes back through the combiner element **1304**, and is directed into the wearer's eye. The wearer can also view

the surrounding environment through the transparency of the combiner element **1304**, collimating mirror **1310**, and outer lens **1302** (if it is included). As described herein elsewhere, various surfaces are polarized to create the optical path for the image light and to provide transparency of the elements such that the wearer can view the surrounding environment. The wearer will generally perceive that the image light forms an image in the FOV **1305**. In embodiments, the outer lens **1302** may be included. The outer lens **1302** is an outer lens that may or may not be corrective and it may be designed to conceal the lower optical module components in an effort to make the HWC appear to be in a form similar to standard glasses or sunglasses.

[0132] In the embodiment illustrated in FIG. **13a**, the effects LEDs **1308a** and **1308b** are positioned at the sides of the combiner element **1304** and the outer lens **1302** and/or the collimating mirror **1310**. In embodiments, the effects LEDs **1308a** are positioned within the confines defined by the combiner element **1304** and the outer lens **1302** and/or the collimating mirror. The effects LEDs **1308a** and **1308b** are also positioned outside of the FOV **1305**. In this arrangement, the effects LEDs **1308a** and **1308b** can provide lighting effects within the lower optical module outside of the FOV **1305**. In embodiments the light emitted from the effects LEDs **1308a** and **1308b** may be polarized such that the light passes through the combiner element **1304** toward the wearer's eye and does not pass through the outer lens **1302** and/or the collimating mirror **1310**. This arrangement provides peripheral lighting effects to the wearer in a more private setting by not transmitting the lighting effects through the front of the HWC into the surrounding environment. However, in other embodiments, the effects LEDs **1308a** and **1308b** may be unpolarized so the lighting effects provided are made to be purposefully viewable by others in the environment for entertainment such as giving the effect of the wearer's eye glowing in correspondence to the image content being viewed by the wearer.

[0133] FIG. **13b** illustrates a cross section of the embodiment described in connection with FIG. **13a**. As illustrated, the effects LED **1308a** is located in the upper-front area inside of the optical components of the lower optical module. It should be understood that the effects LED **1308a** position in the described embodiments is only illustrative and alternate placements are encompassed by the present disclosure. Additionally, in embodiments, there may be one or more effects LEDs **1308a** in each of the two sides of HWC to provide peripheral lighting effects near one or both eyes of the wearer.

[0134] FIG. **13c** illustrates an embodiment where the combiner element **1304** is angled away from the eye at the top and towards the eye at the bottom (e.g. in accordance with the holographic or notch filter embodiments described herein). In this embodiment, the effects LED **1308a** is located on the outer lens **1302** side of the combiner element **1304** to provide a concealed appearance of the lighting effects. As with other embodiments, the effects LED **1308a** of FIG. **13c** may include a polarizer such that the emitted light can pass through a polarized element associated with the combiner element **1304** and be blocked by a polarized element associated with the outer lens **1302**.

[0135] Another aspect of the present disclosure relates to the mitigation of light escaping from the space between the wearer's face and the HWC itself. Another aspect of the present disclosure relates to maintaining a controlled light-

ing environment in proximity to the wearer's eyes. In embodiments, both the maintenance of the lighting environment and the mitigation of light escape are accomplished by including a removable and replaceable flexible shield for the HWC. Wherein the removable and replaceable shield can be provided for one eye or both eyes in correspondence to the use of the displays for each eye. For example, in a night vision application, the display to only one eye could be used for night vision while the display to the other eye is turned off to provide good see-thru when moving between areas where visible light is available and dark areas where night vision enhancement is needed.

[0136] FIG. **14a** illustrates a removable and replaceable flexible eye cover **1402** with an opening **1408** that can be attached and removed quickly from the HWC **102** through the use of magnets. Other attachment methods may be used, but for illustration of the present disclosure we will focus on a magnet implementation. In embodiments, magnets may be included in the eye cover **1402** and magnets of an opposite polarity may be included (e.g. embedded) in the frame of the HWC **102**. The magnets of the two elements would attract quite strongly with the opposite polarity configuration. In another embodiment, one of the elements may have a magnet and the other side may have metal for the attraction. In embodiments, the eye cover **1402** is a flexible elastomeric shield. In embodiments, the eye cover **1402** may be an elastomeric bellows design to accommodate flexibility and more closely align with the wearer's face. FIG. **14b** illustrates a removable and replaceable flexible eye cover **1404** that is adapted as a single eye cover. In embodiments, a single eye cover may be used for each side of the HWC to cover both eyes of the wearer. In embodiments, the single eye cover may be used in connection with a HWC that includes only one computer display for one eye. These configurations prevent light that is generated and directed generally towards the wearer's face by covering the space between the wearer's face and the HWC. The opening **1408** allows the wearer to look through the opening **1408** to view the displayed content and the surrounding environment through the front of the HWC. The image light in the lower optical module **204** can be prevented from emitting from the front of the HWC through internal optics polarization schemes, as described herein, for example.

[0137] FIG. **14c** illustrates another embodiment of a light suppression system. In this embodiment, the eye cover **1410** may be similar to the eye cover **1402**, but eye cover **1410** includes a front light shield **1412**. The front light shield **1412** may be opaque to prevent light from escaping the front lens of the HWC. In other embodiments, the front light shield **1412** is polarized to prevent light from escaping the front lens. In a polarized arrangement, in embodiments, the internal optical elements of the HWC (e.g. of the lower optical module **204**) may polarize light transmitted towards the front of the HWC and the front light shield **1412** may be polarized to prevent the light from transmitting through the front light shield **1412**.

[0138] In embodiments, an opaque front light shield **1412** may be included and the digital content may include images of the surrounding environment such that the wearer can visualize the surrounding environment. One eye may be presented with night vision environmental imagery and this eye's surrounding environment optical path may be covered using an opaque front light shield **1412**. In other embodiments, this arrangement may be associated with both eyes.

[0139] Another aspect of the present disclosure relates to automatically configuring the lighting system(s) used in the HWC 102. In embodiments, the display lighting and/or effects lighting, as described herein, may be controlled in a manner suitable for when an eye cover 1408 is attached or removed from the HWC 102. For example, at night, when the light in the environment is low, the lighting system(s) in the HWC may go into a low light mode to further control any amounts of stray light escaping from the HWC and the areas around the HWC. Covert operations at night, while using night vision or standard vision, may require a solution which prevents as much escaping light as possible so a user may clip on the eye cover(s) 1408 and then the HWC may go into a low light mode. The low light mode may, in some embodiments, only go into a low light mode when the eye cover 1408 is attached if the HWC identifies that the environment is in low light conditions (e.g. through environment light level sensor detection). In embodiments, the low light level may be determined to be at an intermediate point between full and low light dependent on environmental conditions.

[0140] Another aspect of the present disclosure relates to automatically controlling the type of content displayed in the HWC when eye covers 1408 are attached or removed from the HWC. In embodiments, when the eye cover(s) 1408 is attached to the HWC, the displayed content may be restricted in amount or in color amounts. For example, the display(s) may go into a simple content delivery mode to restrict the amount of information displayed. This may be done to reduce the amount of light produced by the display (s). In an embodiment, the display(s) may change from color displays to monochrome displays to reduce the amount of light produced. In an embodiment, the monochrome lighting may be red to limit the impact on the wearer's eyes to maintain an ability to see better in the dark.

[0141] Referring to FIG. 15, we now turn to describe a particular external user interface 104, referred to generally as a pen 1500. The pen 1500 is a specially designed external user interface 104 and can operate as a user interface, such as to many different styles of HWC 102. The pen 1500 generally follows the form of a conventional pen, which is a familiar user handled device and creates an intuitive physical interface for many of the operations to be carried out in the HWC system 100. The pen 1500 may be one of several user interfaces 104 used in connection with controlling operations within the HWC system 100. For example, the HWC 102 may watch for and interpret hand gestures 116 as control signals, where the pen 1500 may also be used as a user interface with the same HWC 102. Similarly, a remote keyboard may be used as an external user interface 104 in concert with the pen 1500. The combination of user interfaces or the use of just one control system generally depends on the operation(s) being executed in the HWC's system 100.

[0142] While the pen 1500 may follow the general form of a conventional pen, it contains numerous technologies that enable it to function as an external user interface 104. FIG. 15 illustrates technologies comprised in the pen 1500. As can be seen, the pen 1500 may include a camera 1508, which is arranged to view through lens 1502. The camera may then be focused, such as through lens 1502, to image a surface upon which a user is writing or making other movements to interact with the HWC 102. There are situations where the pen 1500 will also have an ink, graphite, or other system

such that what is being written can be seen on the writing surface. There are other situations where the pen 1500 does not have such a physical writing system so there is no deposit on the writing surface, where the pen would only be communicating data or commands to the HWC 102. The lens configuration is described in greater detail herein. The function of the camera is to capture information from an unstructured writing surface such that pen strokes can be interpreted as intended by the user. To assist in the predication of the intended stroke path, the pen 1500 may include a sensor, such as an IMU 1512. Of course, the IMU could be included in the pen 1500 in its separate parts (e.g. gyro, accelerometer, etc.) or an IMU could be included as a single unit. In this instance, the IMU 1512 is used to measure and predict the motion of the pen 1500. In turn, the integrated microprocessor 1510 would take the IMU information and camera information as inputs and process the information to form a prediction of the pen tip movement.

[0143] The pen 1500 may also include a pressure monitoring system 1504, such as to measure the pressure exerted on the lens 1502. As will be described in greater detail herein, the pressure measurement can be used to predict the user's intention for changing the weight of a line, type of a line, type of brush, click, double click, and the like. In embodiments, the pressure sensor may be constructed using any force or pressure measurement sensor located behind the lens 1502, including for example, a resistive sensor, a current sensor, a capacitive sensor, a voltage sensor such as a piezoelectric sensor, and the like.

[0144] The pen 1500 may also include a communications module 1518, such as for bi-directional communication with the HWC 102. In embodiments, the communications module 1518 may be a short distance communication module (e.g. Bluetooth). The communications module 1518 may be security matched to the HWC 102. The communications module 1518 may be arranged to communicate data and commands to and from the microprocessor 1510 of the pen 1500. The microprocessor 1510 may be programmed to interpret data generated from the camera 1508, IMU 1512, and pressure sensor 1504, and the like, and then pass a command onto the HWC 102 through the communications module 1518, for example. In another embodiment, the data collected from any of the input sources (e.g. camera 1508, IMU 1512, pressure sensor 1504) by the microprocessor may be communicated by the communication module 1518 to the HWC 102, and the HWC 102 may perform data processing and prediction of the user's intention when using the pen 1500. In yet another embodiment, the data may be further passed on through a network 110 to a remote device 112, such as a server, for the data processing and prediction. The commands may then be communicated back to the HWC 102 for execution (e.g. display writing in the glasses display, make a selection within the UI of the glasses display, control a remote external device 112, control a local external device 108), and the like. The pen may also include memory 1514 for long or short term uses.

[0145] The pen 1500 may also include a number of physical user interfaces, such as quick launch buttons 1522, a touch sensor 1520, and the like. The quick launch buttons 1522 may be adapted to provide the user with a fast way of jumping to a software application in the HWC system 100. For example, the user may be a frequent user of communication software packages (e.g. email, text, Twitter, Instagram, Facebook, Google+, and the like), and the user may

program a quick launch button **1522** to command the HWC **102** to launch an application. The pen **1500** may be provided with several quick launch buttons **1522**, which may be user programmable or factory programmable. The quick launch button **1522** may be programmed to perform an operation. For example, one of the buttons may be programmed to clear the digital display of the HWC **102**. This would create a fast way for the user to clear the screens on the HWC **102** for any reason, such as for example to better view the environment. The quick launch button functionality will be discussed in further detail below. The touch sensor **1520** may be used to take gesture style input from the user. For example, the user may be able to take a single finger and run it across the touch sensor **1520** to affect a page scroll.

[0146] The pen **1500** may also include a laser pointer **1524**. The laser pointer **1524** may be coordinated with the IMU **1512** to coordinate gestures and laser pointing. For example, a user may use the laser **1524** in a presentation to help with guiding the audience with the interpretation of graphics and the IMU **1512** may, either simultaneously or when the laser **1524** is off, interpret the user's gestures as commands or data input.

[0147] FIGS. 16A-C illustrate several embodiments of lens and camera arrangements **1600** for the pen **1500**. One aspect relates to maintaining a constant distance between the camera and the writing surface to enable the writing surface to be kept in focus for better tracking of movements of the pen **1500** over the writing surface. Another aspect relates to maintaining an angled surface following the circumference of the writing tip of the pen **1500** such that the pen **1500** can be rolled or partially rolled in the user's hand to create the feel and freedom of a conventional writing instrument.

[0148] FIG. 16A illustrates an embodiment of the writing lens end of the pen **1500**. The configuration includes a ball lens **1604**, a camera or image capture surface **1602**, and a domed cover lens **1608**. In this arrangement, the camera views the writing surface through the ball lens **1604** and dome cover lens **1608**. The ball lens **1604** causes the camera to focus such that the camera views the writing surface when the pen **1500** is held in the hand in a natural writing position, such as with the pen **1500** in contact with a writing surface. In embodiments, the ball lens **1604** should be separated from the writing surface to obtain the highest resolution of the writing surface at the camera **1602**. In embodiments, the ball lens **1604** is separated by approximately 1 to 3 mm. In this configuration, the domed cover lens **1608** provides a surface that can keep the ball lens **1604** separated from the writing surface at a constant distance, such as substantially independent of the angle used to write on the writing surface. For instance, in embodiments the field of view of the camera in this arrangement would be approximately 60 degrees.

[0149] The domed cover lens, or other lens **1608** used to physically interact with the writing surface, will be transparent or transmissive within the active bandwidth of the camera **1602**. In embodiments, the domed cover lens **1608** may be spherical or other shape and comprised of glass, plastic, sapphire, diamond, and the like. In other embodiments where low resolution imaging of the surface is acceptable. The pen **1500** can omit the domed cover lens **1608** and the ball lens **1604** can be in direct contact with the surface.

[0150] FIG. 16B illustrates another structure where the construction is somewhat similar to that described in connection with FIG. 16A; however this embodiment does not

use a dome cover lens **1608**, but instead uses a spacer **1610** to maintain a predictable distance between the ball lens **1604** and the writing surface, wherein the spacer may be spherical, cylindrical, tubular or other shape that provides spacing while allowing for an image to be obtained by the camera **1602** through the lens **1604**. In a preferred embodiment, the spacer **1610** is transparent. In addition, while the spacer **1610** is shown as spherical, other shapes such as an oval, doughnut shape, half sphere, cone, cylinder or other form may be used.

[0151] FIG. 16C illustrates yet another embodiment, where the structure includes a post **1614**, such as running through the center of the lensed end of the pen **1500**. The post **1614** may be an ink deposition system (e.g. ink cartridge), graphite deposition system (e.g. graphite holder), or a dummy post whose purpose is mainly only that of alignment. The selection of the post type is dependent on the pen's use. For instance, in the event the user wants to use the pen **1500** as a conventional ink depositing pen as well as a fully functional external user interface **104**, the ink system post would be the best selection. If there is no need for the 'writing' to be visible on the writing surface, the selection would be the dummy post. The embodiment of FIG. 16C includes camera(s) **1602** and an associated lens **1612**, where the camera **1602** and lens **1612** are positioned to capture the writing surface without substantial interference from the post **1614**. In embodiments, the pen **1500** may include multiple cameras **1602** and lenses **1612** such that more or all of the circumference of the tip **1614** can be used as an input system. In an embodiment, the pen **1500** includes a contoured grip that keeps the pen aligned in the user's hand so that the camera **1602** and lens **1612** remains pointed at the surface.

[0152] Another aspect of the pen **1500** relates to sensing the force applied by the user to the writing surface with the pen **1500**. The force measurement may be used in a number of ways. For example, the force measurement may be used as a discrete value, or discontinuous event tracking, and compared against a threshold in a process to determine a user's intent. The user may want the force interpreted as a 'click' in the selection of an object, for instance. The user may intend multiple force exertions interpreted as multiple clicks. There may be times when the user holds the pen **1500** in a certain position or holds a certain portion of the pen **1500** (e.g. a button or touch pad) while clicking to affect a certain operation (e.g. a 'right click'). In embodiments, the force measurement may be used to track force and force trends. The force trends may be tracked and compared to threshold limits, for example. There may be one such threshold limit, multiple limits, groups of related limits, and the like. For example, when the force measurement indicates a fairly constant force that generally falls within a range of related threshold values, the microprocessor **1510** may interpret the force trend as an indication that the user desires to maintain the current writing style, writing tip type, line weight, brush type, and the like. In the event that the force trend appears to have gone outside of a set of threshold values intentionally, the microprocessor may interpret the action as an indication that the user wants to change the current writing style, writing tip type, line weight, brush type, and the like. Once the microprocessor has made a determination of the user's intent, a change in the current writing style, writing tip type, line weight, brush type, and the like may be executed. In embodiments, the change may

be noted to the user (e.g. in a display of the HWC 102), and the user may be presented with an opportunity to accept the change.

[0153] FIG. 17A illustrates an embodiment of a force sensing surface tip 1700 of a pen 1500. The force sensing surface tip 1700 comprises a surface connection tip 1702 (e.g. a lens as described herein elsewhere) in connection with a force or pressure monitoring system 1504. As a user uses the pen 1500 to write on a surface or simulate writing on a surface the force monitoring system 1504 measures the force or pressure the user applies to the writing surface and the force monitoring system communicates data to the microprocessor 1510 for processing. In this configuration, the microprocessor 1510 receives force data from the force monitoring system 1504 and processes the data to make predictions of the user's intent in applying the particular force that is currently being applied. In embodiments, the processing may be provided at a location other than on the pen (e.g. at a server in the HWC system 100, on the HWC 102). For clarity, when reference is made herein to processing information on the microprocessor 1510, the processing of information contemplates processing the information at a location other than on the pen. The microprocessor 1510 may be programmed with force threshold(s), force signature(s), force signature library and/or other characteristics intended to guide an inference program in determining the user's intentions based on the measured force or pressure. The microprocessor 1510 may be further programmed to make inferences from the force measurements as to whether the user has attempted to initiate a discrete action (e.g. a user interface selection 'click') or is performing a constant action (e.g. writing within a particular writing style). The inferencing process is important as it causes the pen 1500 to act as an intuitive external user interface 104.

[0154] FIG. 17B illustrates a force 1708 versus time 1710 trend chart with a single threshold 1718. The threshold 1718 may be set at a level that indicates a discrete force exertion indicative of a user's desire to cause an action (e.g. select an object in a GUI). Event 1712, for example, may be interpreted as a click or selection command because the force quickly increased from below the threshold 1718 to above the threshold 1718. The event 1714 may be interpreted as a double click because the force quickly increased above the threshold 1718, decreased below the threshold 1718 and then essentially repeated quickly. The user may also cause the force to go above the threshold 1718 and hold for a period indicating that the user is intending to select an object in the GUI (e.g. a GUI presented in the display of the HWC 102) and 'hold' for a further operation (e.g. moving the object).

[0155] While a threshold value may be used to assist in the interpretation of the user's intention, a signature force event trend may also be used. The threshold and signature may be used in combination or either method may be used alone. For example, a single-click signature may be represented by a certain force trend signature or set of signatures. The single-click signature(s) may require that the trend meet a criteria of a rise time between x any y values, a hold time of between a and b values and a fall time of between c and d values, for example. Signatures may be stored for a variety of functions such as click, double click, right click, hold, move, etc. The microprocessor 1510 may compare the real-time force or pressure tracking against the signatures

from a signature library to make a decision and issue a command to the software application executing in the GUI.

[0156] FIG. 17C illustrates a force 1708 versus time 1710 trend chart with multiple thresholds 1718. By way of example, the force trend is plotted on the chart with several pen force or pressure events. As noted, there are both presumably intentional events 1720 and presumably non-intentional events 1722. The two thresholds 1718 of FIG. 4C create three zones of force: a lower, middle and higher range. The beginning of the trend indicates that the user is placing a lower zone amount of force. This may mean that the user is writing with a given line weight and does not intend to change the weight, the user is writing. Then the trend shows a significant increase 1720 in force into the middle force range. This force change appears, from the trend to have been sudden and thereafter it is sustained. The microprocessor 1510 may interpret this as an intentional change and as a result change the operation in accordance with preset rules (e.g. change line width, increase line weight, etc.). The trend then continues with a second apparently intentional event 1720 into the higher-force range. During the performance in the higher-force range, the force dips below the upper threshold 1718. This may indicate an unintentional force change and the microprocessor may detect the change in range however not affect a change in the operations being coordinated by the pen 1500. As indicated above, the trend analysis may be done with thresholds and/or signatures.

[0157] Generally, in the present disclosure, instrument stroke parameter changes may be referred to as a change in line type, line weight, tip type, brush type, brush width, brush pressure, color, and other forms of writing, coloring, painting, and the like.

[0158] Another aspect of the pen 1500 relates to selecting an operating mode for the pen 1500 dependent on contextual information and/or selection interface(s). The pen 1500 may have several operating modes. For instance, the pen 1500 may have a writing mode where the user interface(s) of the pen 1500 (e.g. the writing surface end, quick launch buttons 1522, touch sensor 1520, motion based gesture, and the like) is optimized or selected for tasks associated with writing. As another example, the pen 1500 may have a wand mode where the user interface(s) of the pen is optimized or selected for tasks associated with software or device control (e.g. the HWC 102, external local device, remote device 112, and the like). The pen 1500, by way of another example, may have a presentation mode where the user interface(s) is optimized or selected to assist a user with giving a presentation (e.g. pointing with the laser pointer 1524 while using the button(s) 1522 and/or gestures to control the presentation or applications relating to the presentation). The pen may, for example, have a mode that is optimized or selected for a particular device that a user is attempting to control. The pen 1500 may have a number of other modes and an aspect of the present disclosure relates to selecting such modes.

[0159] FIG. 18A illustrates an automatic user interface(s) mode selection based on contextual information. The microprocessor 1510 may be programmed with IMU thresholds 1814 and 1812. The thresholds 1814 and 1812 may be used as indications of upper and lower bounds of an angle 1804 and 1802 of the pen 1500 for certain expected positions during certain predicted modes. When the microprocessor 1510 determines that the pen 1500 is being held or otherwise positioned within angles 1802 corresponding to writing thresholds 1814, for example, the microprocessor 1510 may

then institute a writing mode for the pen's user interfaces. Similarly, if the microprocessor 1510 determines (e.g. through the IMU 1512) that the pen is being held at an angle 1804 that falls between the predetermined wand thresholds 1812, the microprocessor may institute a wand mode for the pen's user interface. Both of these examples may be referred to as context based user interface mode selection as the mode selection is based on contextual information (e.g. position) collected automatically and then used through an automatic evaluation process to automatically select the pen's user interface(s) mode.

[0160] As with other examples presented herein, the microprocessor 1510 may monitor the contextual trend (e.g. the angle of the pen over time) in an effort to decide whether to stay in a mode or change modes. For example, through signatures, thresholds, trend analysis, and the like, the microprocessor may determine that a change is an unintentional change and therefore no user interface mode change is desired.

[0161] FIG. 18B illustrates an automatic user interface(s) mode selection based on contextual information. In this example, the pen 1500 is monitoring (e.g. through its microprocessor) whether or not the camera at the writing surface end 1508 is imaging a writing surface in close proximity to the writing surface end of the pen 1500. If the pen 1500 determines that a writing surface is within a predetermined relatively short distance, the pen 1500 may decide that a writing surface is present 1820 and the pen may go into a writing mode user interface(s) mode. In the event that the pen 1500 does not detect a relatively close writing surface 1822, the pen may predict that the pen is not currently being used to as a writing instrument and the pen may go into a non-writing user interface(s) mode.

[0162] FIG. 18C illustrates a manual user interface(s) mode selection. The user interface(s) mode may be selected based on a twist of a section 1824 of the pen 1500 housing, clicking an end button 1828, pressing a quick launch button 1522, interacting with touch sensor 1520, detecting a predetermined action at the pressure monitoring system (e.g. a click), detecting a gesture (e.g. detected by the IMU), etc. The manual mode selection may involve selecting an item in a GUI associated with the pen 1500 (e.g. an image presented in the display of HWC 102).

[0163] In embodiments, a confirmation selection may be presented to the user in the event a mode is going to change. The presentation may be physical (e.g. a vibration in the pen 1500), through a GUI, through a light indicator, etc.

[0164] FIG. 19 illustrates a couple pen use-scenarios 1900 and 1901. There are many use scenarios and we have presented a couple in connection with FIG. 19 as a way of illustrating use scenarios to further the understanding of the reader. As such, the use-scenarios should be considered illustrative and non-limiting.

[0165] Use scenario 1900 is a writing scenario where the pen 1500 is used as a writing instrument. In this example, quick launch button 122A is pressed to launch a note application 1910 in the GUI 1908 of the HWC 102 display 1904. Once the quick launch button 122A is pressed, the HWC 102 launches the note program 1910 and puts the pen into a writing mode. The user uses the pen 1500 to scribe symbols 1902 on a writing surface, the pen records the scribing and transmits the scribing to the HWC 102 where symbols representing the scribing are displayed 1912 within the note application 1910.

[0166] Use scenario 1901 is a gesture scenario where the pen 1500 is used as a gesture capture and command device. In this example, the quick launch button 122B is activated and the pen 1500 activates a wand mode such that an application launched on the HWC 102 can be controlled. Here, the user sees an application chooser 1918 in the display(s) of the HWC 102 where different software applications can be chosen by the user. The user gestures (e.g. swipes, spins, turns, etc.) with the pen to cause the application chooser 1918 to move from application to application. Once the correct application is identified (e.g. highlighted) in the chooser 1918, the user may gesture or click or otherwise interact with the pen 1500 such that the identified application is selected and launched. Once an application is launched, the wand mode may be used to scroll, rotate, change applications, select items, initiate processes, and the like, for example.

[0167] In an embodiment, the quick launch button 122A may be activated and the HWC 102 may launch an application chooser presenting to the user a set of applications. For example, the quick launch button may launch a chooser to show all communication programs (e.g. SMS, Twitter, Instagram, Facebook, email, etc.) available for selection such that the user can select the program the user wants and then go into a writing mode. By way of further example, the launcher may bring up selections for various other groups that are related or categorized as generally being selected at a given time (e.g. Microsoft Office products, communication products, productivity products, note products, organizational products, and the like)

[0168] FIG. 20 illustrates yet another embodiment of the present disclosure. FIG. 2000 illustrates a watchband clip on controller 2000. The watchband clip on controller may be a controller used to control the HWC 102 or devices in the HWC system 100. The watchband clip on controller 2000 has a fastener 2018 (e.g. rotatable clip) that is mechanically adapted to attach to a watchband, as illustrated at 2004.

[0169] The watchband controller 2000 may have quick launch interfaces 2008 (e.g. to launch applications and choosers as described herein), a touch pad 2014 (e.g. to be used as a touch style mouse for GUI control in a HWC 102 display) and a display 2012. The clip 2018 may be adapted to fit a wide range of watchbands so it can be used in connection with a watch that is independently selected for its function. The clip, in embodiments, is rotatable such that a user can position it in a desirable manner. In embodiments the clip may be a flexible strap. In embodiments, the flexible strap may be adapted to be stretched to attach to a hand, wrist, finger, device, weapon, and the like.

[0170] In embodiments, the watchband controller may be configured as a removable and replaceable watchband. For example, the controller may be incorporated into a band with a certain width, segment spacing's, etc. such that the watchband, with its incorporated controller, can be attached to a watch body. The attachment, in embodiments, may be mechanically adapted to attach with a pin upon which the watchband rotates. In embodiments, the watchband controller may be electrically connected to the watch and/or watch body such that the watch, watch body and/or the watchband controller can communicate data between them.

[0171] The watchband controller may have 3-axis motion monitoring (e.g. through an IMU, accelerometers, magnetometers, gyroscopes, etc.) to capture user motion. The user motion may then be interpreted for gesture control.

[0172] In embodiments, the watchband controller may comprise fitness sensors and a fitness computer. The sensors may track heart rate, calories burned, strides, distance covered, and the like. The data may then be compared against performance goals and/or standards for user feedback.

[0173] Another aspect of the present disclosure relates to visual display techniques relating to micro Doppler (“mD”) target tracking signatures (“mD signatures”). mD is a radar technique that uses a series of angle dependent electromagnetic pulses that are broadcast into an environment and return pulses are captured. Changes between the broadcast pulse and return pulse are indicative of changes in the shape, distance and angular location of objects or targets in the environment. These changes provide signals that can be used to track a target and identify the target through the mD signature. Each target or target type has a unique mD signature. Shifts in the radar pattern can be analyzed in the time domain and frequency domain based on mD techniques to derive information about the types of targets present (e.g. whether people are present), the motion of the targets and the relative angular location of the targets and the distance to the targets. By selecting a frequency used for the mD pulse relative to known objects in the environment, the pulse can penetrate the known objects to enable information about targets to be gathered even when the targets are visually blocked by the known objects. For example, pulse frequencies can be used that will penetrate concrete buildings to enable people to be identified inside the building. Multiple pulse frequencies can be used as well in the mD radar to enable different types of information to be gathered about the objects in the environment. In addition, the mD radar information can be combined with other information such as distance measurements or images captured of the environment that are analyzed jointly to provide improved object identification and improved target identification and tracking. In embodiments, the analysis can be performed on the HWC or the information can be transmitted to a remote network for analysis and results transmitted back to the HWC. Distance measurements can be provided by laser range finding, structured lighting, stereoscopic depth maps or sonar measurements. Images of the environment can be captured using one or more cameras capable of capturing images from visible, ultraviolet or infrared light. The mD radar can be attached to the HWC, located adjacently (e.g. in a vehicle) and associated wirelessly with the HWC or located remotely. Maps or other previously determined information about the environment can also be used in the analysis of the mD radar information. Embodiments of the present disclosure relate to visualizing the mD signatures in useful ways.

[0174] FIG. 21 illustrates a FOV 2102 of a HWC 102 from a wearer’s perspective. The wearer, as described herein elsewhere, has a see-through FOV 2102 wherein the wearer views adjacent surroundings, such as the buildings illustrated in FIG. 21. The wearer, as described herein elsewhere, can also see displayed digital content presented within a portion of the FOV 2102. The embodiment illustrated in FIG. 21 is indicating that the wearer can see the buildings and other surrounding elements in the environment and digital content representing traces, or travel paths, of bullets being fired by different people in the area. The surroundings are viewed through the transparency of the FOV 2102. The traces are presented via the digital computer display, as described herein elsewhere. In embodiments, the trace pre-

sented is based on a mD signature that is collected and communicated to the HWC in real time. The mD radar itself may be on or near the wearer of the HWC 102 or it may be located remote from the wearer. In embodiments, the mD radar scans the area, tracks and identifies targets, such as bullets, and communicates traces, based on locations, to the HWC 102.

[0175] There are several traces 2108 and 2104 presented to the wearer in the embodiment illustrated in FIG. 21. The traces communicated from the mD radar may be associated with GPS locations and the GPS locations may be associated with objects in the environment, such as people, buildings, vehicles, etc, both in latitude and longitude perspective and an elevation perspective. The locations may be used as markers for the HWC such that the traces, as presented in the FOV, can be associated, or fixed in space relative to the markers. For example, if the friendly fire trace 2108 is determined, by the mD radar, to have originated from the upper right window of the building on the left, as illustrated in FIG. 21, then a virtual marker may be set on or near the window. When the HWC views, through its camera or other sensor, for example, the building’s window, the trace may then virtually anchor with the virtual marker on the window. Similarly, a marker may be set near the termination position or other flight position of the friendly fire trace 2108, such as the upper left window of the center building on the right, as illustrated in FIG. 21. This technique fixes in space the trace such that the trace appears fixed to the environmental positions independent of where the wearer is looking. So, for example, as the wearer’s head turns, the trace appears fixed to the marked locations.

[0176] In embodiments, certain user positions may be known and thus identified in the FOV. For example, the shooter of the friendly fire trace 2108 may be from a known friendly combatant and as such his location may be known. The position may be known based on his GPS location based on a mobile communication system on him, such as another HWC 102. In other embodiments, the friendly combatant may be marked by another friendly. For example, if the friendly position in the environment is known through visual contact or communicated information, a wearer of the HWC 102 may use a gesture or external user interface 104 to mark the location. If a friendly combatant location is known the originating position of the friendly fire trace 2108 may be color coded or otherwise distinguished from unidentified traces on the displayed digital content. Similarly, enemy fire traces 2104 may be color coded or otherwise distinguished on the displayed digital content. In embodiments, there may be an additional distinguished appearance on the displayed digital content for unknown traces.

[0177] In addition to situationally associated trace appearance, the trace colors or appearance may be different from the originating position to the terminating position. This path appearance change may be based on the mD signature. The mD signature may indicate that the bullet, for example, is slowing as it propagates and this slowing pattern may be reflected in the FOV 2102 as a color or pattern change. This can create an intuitive understanding of where the shooter is located. For example, the originating color may be red, indicative of high speed, and it may change over the course of the trace to yellow, indicative of a slowing trace. This pattern changing may also be different for a friendly, enemy and unknown combatant. The enemy may go blue to green for a friendly trace, for example.

[0178] FIG. 21 illustrates an embodiment where the user sees the environment through the FOV and may also see color coded traces, which are dependent on bullet speed and combatant type, where the traces are fixed in environmental positions independent on the wearer's perspective. Other information, such as distance, range, range rings, time of day, date, engagement type (e.g. hold, stop firing, back away, etc.) may also be displayed in the FOV.

[0179] Another aspect of the present disclosure relates to mD radar techniques that trace and identify targets through other objects, such as walls (referred to generally as through wall mD), and visualization techniques related therewith. FIG. 22 illustrates a through wall mD visualization technique according to the principles of the present disclosure. As described herein elsewhere, the mD radar scanning the environment may be local or remote from the wearer of a HWC 102. The mD radar may identify a target (e.g. a person) that is visible 2204 and then track the target as he goes behind a wall 2208. The tracking may then be presented to the wearer of a HWC 102 such that digital content reflective of the target and the target's movement, even behind the wall, is presented in the FOV 2202 of the HWC 102. In embodiments, the target, when out of visible sight, may be represented by an avatar in the FOV to provide the wearer with imagery representing the target.

[0180] mD target recognition methods can identify the identity of a target based on the vibrations and other small movements of the target. This can provide a personal signature for the target. In the case of humans, this may result in a personal identification of a target that has been previously characterized. The cardio, heartbeat, lung expansion and other small movements within the body may be unique to a person and if those attributes are pre-identified they may be matched in real time to provide a personal identification of a person in the FOV 2202. The person's mD signatures may be determined based on the position of the person. For example, the database of personal mD signature attributes may include mD signatures for a person standing, sitting, laying down, running, walking, jumping, etc. This may improve the accuracy of the personal data match when a target is tracked through mD signature techniques in the field. In the event a person is personally identified, a specific indication of the person's identity may be presented in the FOV 2202. The indication may be a color, shape, shade, name, indication of the type of person (e.g. enemy, friendly, etc.), etc. to provide the wearer with intuitive real time information about the person being tracked. This may be very useful in a situation where there is more than one person in an area of the person being tracked. If just one person in the area is personally identified, that person or the avatar of that person can be presented differently than other people in the area.

[0181] FIG. 23 illustrates an mD scanned environment 2300. An mD radar may scan an environment in an attempt to identify objects in the environment. In this embodiment, the mD scanned environment reveals two vehicles 2302a and 2302b, an enemy combatant 2309, two friendly combatants 2308a and 2308b and a shot trace 2318. Each of these objects may be personally identified or type identified. For example, the vehicles 2302a and 2302b may be identified through the mD signatures as a tank and heavy truck. The enemy combatant 2309 may be identified as a type (e.g. enemy combatant) or more personally (e.g. by name). The friendly combatants may be identified as a type (e.g. friendly

combatant) or more personally (e.g. by name). The shot trace 2318 may be characterized by type of projectile or weapon type for the projectile, for example.

[0182] FIG. 23a illustrates two separate HWC 102 FOV display techniques according to the principles of the present disclosure. FOV 2312 illustrates a map view 2310 where the mD scanned environment is presented. Here, the wearer has a perspective on the mapped area so he can understand all tracked targets in the area. This allows the wearer to traverse the area with knowledge of the targets. FOV 2312 illustrates a heads-up view to provide the wearer with an augmented reality style view of the environment that is in proximity of the wearer.

[0183] An aspect of the present disclosure relates to suppression of extraneous or stray light. As discussed herein elsewhere, eyeglow and faceglow are two such artifacts that develop from such light. Eyeglow and faceglow can be caused by image light escaping from the optics module. The escaping light is then visible, particularly in dark environments when the user is viewing bright displayed images with the HWC. Light that escapes through the front of the HWC is visible as eyeglow as it that light that is visible in the region of the user's eyes. Eyeglow can appear in the form of a small version of the displayed image that the user is viewing. Light that escapes from the bottom of the HWC shines onto the user's face, cheek or chest so that these portions of the user appear to glow. Eyeglow and faceglow can both increase the visibility of the user and highlight the use of the HWC, which may be viewed negatively by the user. As such, reducing eyeglow and faceglow is advantageous. In combat situations (e.g. the mD trace presentation scenarios described herein) and certain gaming situations, the suppression of extraneous or stray light is very important.

[0184] The disclosure relating to FIG. 6 shows an example where a portion of the image light passes through the combiner 602 such that the light shines onto the user's face, thereby illuminating a portion of the user's face in what is generally referred to herein as faceglow. Faceglow be caused by any portion of light from the HWC that illuminates the user's face.

[0185] An example of the source for the faceglow light can come from wide cone angle light associated with the image light incident onto the combiner 602. Where the combiner can include a holographic mirror or a notch mirror in which the narrow bands of high reflectivity are matched to wavelengths of light by the light source. The wide cone angle associated with the image light corresponds with the field of view provided by the HWC. Typically the reflectivity of holographic mirrors and notch mirrors is reduced as the cone angle of the incident light is increased above 8 degrees. As a result, for a field of view of 30 degrees, substantial image light can pass through the combiner and cause faceglow.

[0186] FIG. 24 shows an illustration of a light trap 2410 for the faceglow light. In this embodiment, an extension of the outer shield lens of the HWC is coated with a light absorbing material in the region where the converging light responsible for faceglow is absorbed in a light trap 2410. The light absorbing material can be black or it can be a filter designed to absorb only the specific wavelengths of light provided by the light source(s) in the HWC. In addition, the surface of the light trap 2410 may be textured or fibrous to further improve the absorption.

[0187] FIG. 25 illustrates an optical system for a HWC that includes an outer absorptive polarizer 2520 to block the faceglow light. In this embodiment, the image light is polarized and as a result the light responsible for faceglow is similarly polarized. The absorptive polarizer is oriented with a transmission axis such that the faceglow light is absorbed and not transmitted. In this case, the rest of the imaging system in the HWC may not require polarized image light and the image light may be polarized at any point before the combiner. In embodiments, the transmission axis of the absorptive polarizer 2520 is oriented vertically so that external glare from water (S polarized light) is absorbed and correspondingly, the polarization of the image light is selected to be horizontal (S polarization). Consequently, image light that passes through the combiner 602 and is then incident onto the absorptive polarizer 2520, is absorbed. In FIG. 25 the absorptive polarizer 2520 is shown outside the shield lens, alternatively the absorptive polarizer 2520 can be located inside the shield lens.

[0188] FIG. 26 illustrates an optical system for a HWC that includes a film with an absorptive notch filter 2620. In this case, the absorptive notch filter absorbs narrow bands of light that are selected to match the light provided by the optical system's light source. As a result, the absorptive notch filter is opaque with respect to the faceglow light and is transparent to the remainder of the wavelengths included in the visible spectrum so that the user has a clear view of the surrounding environment. A triple notch filter suitable for this approach is available from Iridian Spectral Technologies, Ottawa, ON: <http://www.ilphotonics.com/cdv2/Iridian-Interference%20Filters/New%20filters/Triple%20Notch%20Filter.pdf>

[0189] In embodiments, the combiner 602 may include a notch mirror coating to reflect the wavelengths of light in the image light and a notch filter 2620 can be selected in correspondence to the wavelengths of light provided by the light source and the narrow bands of high reflectivity provided by the notch mirror. In this way, image light that is not reflected by the notch mirror is absorbed by the notch filter 2620. In embodiments of the disclosure the light source can provide one narrow band of light for a monochrome imaging or three narrow bands of light for full color imaging. The notch mirror and associated notch filter would then each provide one narrow band or three narrow bands of high reflectivity and absorption respectively.

[0190] FIG. 27 includes a microlouver film 2750 to block the faceglow light. Microlouver film is sold by 3M as ALCF-P, for example and is typically used as a privacy filter for computer. See [http://multimedia.3m.com/mws/mediawebserver?mwsId=SSSSSuH8gc7nZxtUoY_xIY_eevUqel7zhVtSevTSevTSeSSSSSS--&fn=ALCF-P_ABR2_Control_Film_DS.pdf](http://multimedia.3m.com/mws/mediawebserver?mwsId=SSSSSuH8gc7nZxtUoY_xIY_eevUqel7zhVtSevTSeSSSSSS--&fn=ALCF-P_ABR2_Control_Film_DS.pdf) The microlouver film transmits light within a somewhat narrow angle (e.g. 30 degrees of normal and absorbs light beyond 30 degrees of normal). In FIG. 27, the microlouver film 2750 is positioned such that the faceglow light 2758 is incident beyond 30 degrees from normal while the see-through light 2755 is incident within 30 degrees of normal to the microlouver film 2750. As such, the faceglow light 2758 is absorbed by the microlouver film and the see-through light 2755 is transmitted so that the user has a bright see-thru view of the surrounding environment.

[0191] We now turn back to a description of eye imaging technologies. Aspects of the present disclosure relate to various methods of imaging the eye of a person wearing the

HWC 102. In embodiments, technologies for imaging the eye using an optical path involving the "off" state and "no power" state, which is described in detail below, are described. In embodiments, technologies for imaging the eye with optical configurations that do not involve reflecting the eye image off of DLP mirrors is described. In embodiments, unstructured light, structured light, or controlled lighting conditions, are used to predict the eye's position based on the light reflected off of the front of the wearer's eye. In embodiments, a reflection of a presented digital content image is captured as it reflects off of the wearer's eye and the reflected image may be processed to determine the quality (e.g. sharpness) of the image presented. In embodiments, the image may then be adjusted (e.g. focused differently) to increase the quality of the image presented based on the image reflection.

[0192] FIGS. 28a, 28b and 28c show illustrations of the various positions of the DLP mirrors. FIG. 28a shows the DLP mirrors in the "on" state 2815. With the mirror in the "on" state 2815, illumination light 2810 is reflected along an optical axis 2820 that extends into the lower optical module 204. FIG. 28b shows the DLP mirrors in the "off" state 2825. With the mirror in the "off" state 2825, illumination light 2810 is reflected along an optical axis 2830 that is substantially to the side of optical axis 2820 so that the "off" state light is directed toward a dark light trap as has been described herein elsewhere. FIG. 28c shows the DLP mirrors in a third position, which occurs when no power is applied to the DLP. This "no power" state differs from the "on" and "off" states in that the mirror edges are not in contact with the substrate and as such are less accurately positioned. FIG. 28c shows all of the DLP mirrors in the "no power" state 2835. The "no power" state is achieved by simultaneously setting the voltage to zero for the "on" contact and "off" contact for a DLP mirror, as a result, the mirror returns to a no stress position where the DLP mirror is in the plane of the DLP platform as shown in FIG. 28c. Although not normally done, it is also possible to apply the "no power" state to individual DLP mirrors. When the DLP mirrors are in the "no power" state they do not contribute image content. Instead, as shown in FIG. 28c, when the DLP mirrors are in the "no power" state, the illumination light 2810 is reflected along an optical axis 2840 that is between the optical axes 2820 and 2830 that are respectively associated with the "on" and "off" states and as such this light doesn't contribute to the displayed image as a bright or dark pixel. This light can however contribute scattered light into the lower optical module 204 and as a result the displayed image contrast can be reduced or artifacts can be created in the image that detract from the image content. Consequently, it is generally desirable, in embodiments, to limit the time associated with the "no power" state to times when images are not displayed or to reduce the time associated with having DLP mirrors in the "no power" state so that the effect of the scattered light is reduced.

[0193] FIG. 29 shows an embodiment of the disclosure that can be used for displaying digital content images to a wearer of the HWC 102 and capturing images of the wearer's eye. In this embodiment, light from the eye 2971 passes back through the optics in the lower module 204, the solid corrective wedge 2966, at least a portion of the light passes through the partially reflective layer 2960, the solid illumination wedge 2964 and is reflected by a plurality of DLP mirrors on the DLP 2955 that are in the "no power"

state. The reflected light then passes back through the illumination wedge 2964 and at least a portion of the light is reflected by the partially reflective layer 2960 and the light is captured by the camera 2980.

[0194] For comparison, illuminating light rays 2973 from the light source 2958 are also shown being reflected by the partially reflective layer 2960. Where the angle of the illuminating light 2973 is such that the DLP mirrors, when in the “on” state, reflect the illuminating light 2973 to form image light 2969 that substantially shares the same optical axis as the light from the wearer’s eye 2971. In this way, images of the wearer’s eye are captured in a field of view that overlaps the field of view for the displayed image content. In contrast, light reflected by DLP mirrors in the “off” state form dark light 2975 which is directed substantially to the side of the image light 2969 and the light from eye 2971. Dark light 2975 is directed toward a light trap 2962 that absorbs the dark light to improve the contrast of the displayed image as has been described above in this specification.

[0195] In an embodiment, partially reflective layer 2960 is a reflective polarizer. The light that is reflected from the eye 2971 can then be polarized prior to entering the corrective wedge 2966 (e.g. with an absorptive polarizer between the upper module 202 and the lower module 204), with a polarization orientation relative to the reflective polarizer that enables the light reflected from the eye 2971 to substantially be transmitted by the reflective polarizer. A quarter wave retarder layer 2957 is then included adjacent to the DLP 2955 (as previously disclosed in FIG. 3b) so that the light reflected from the eye 2971 passes through the quarter wave retarder layer 2957 once before being reflected by the plurality of DLP mirrors in the “no power” state and then passes through a second time after being reflected. By passing through the quarter wave retarder layer 2957 twice, the polarization state of the light from the eye 2971 is reversed, such that when it is incident upon the reflective polarizer, the light from the eye 2971 is then substantially reflected toward the camera 2980. By using a partially reflective layer 2960 that is a reflective polarizer and polarizing the light from the eye 2971 prior to entering the corrective wedge 2964, losses attributed to the partially reflective layer 2960 are reduced.

[0196] FIG. 28c shows the case wherein the DLP mirrors are simultaneously in the “no power” state, this mode of operation can be particularly useful when the HWC 102 is first put onto the head of the wearer. When the HWC 102 is first put onto the head of the wearer, it is not necessary to display an image yet. As a result, the DLP can be in a “no power” state for all the DLP mirrors and an image of the wearer’s eyes can be captured. The captured image of the wearer’s eye can then be compared to a database, using iris identification techniques, or other eye pattern identification techniques to determine, for example, the identity of the wearer.

[0197] In a further embodiment illustrated by FIG. 29 all of the DLP mirrors are put into the “no power” state for a portion of a frame time (e.g. 50% of a frame time for the displayed digital content image) and the capture of the eye image is synchronized to occur at the same time and for the same duration. By reducing the time that the DLP mirrors are in the “no power” state, the time where light is scattered by the DLP mirrors being in the “no power” state is reduced such that the wearer doesn’t perceive a change in the

displayed image quality. This is possible because the DLP mirrors have a response time on the order of microseconds while typical frame times for a displayed image are on the order of 0.016 seconds. This method of capturing images of the wearer’s eye can be used periodically to capture repetitive images of the wearer’s eye. For example, eye images could be captured for 50% of the frame time of every 10th frame displayed to the wearer. In another example, eye images could be captured for 10% of the frame time of every frame displayed to the wearer.

[0198] Alternately, the “no power” state can be applied to a subset of the DLP mirrors (e.g. 10% of the DLP mirrors) within while another subset is in busy generating image light for content to be displayed. This enables the capture of an eye image(s) during the display of digital content to the wearer. The DLP mirrors used for eye imaging can, for example, be distributed randomly across the area of the DLP to minimize the impact on the quality of the digital content being displayed to the wearer. To improve the displayed image perceived by the wearer, the individual DLP mirrors put into the “no power” state for capturing each eye image, can be varied over time such as in a random pattern, for example. In yet a further embodiment, the DLP mirrors put into the “no power” state for eye imaging may be coordinated with the digital content in such a way that the “no power” mirrors are taken from a portion of the image that requires less resolution.

[0199] In the embodiments of the disclosure as illustrated in FIGS. 9 and 29, in both cases the reflective surfaces provided by the DLP mirrors do not preserve the wavefront of the light from the wearer’s eye so that the image quality of captured image of the eye is somewhat limited. It may still be useful in certain embodiments, but it is somewhat limited. This is due to the DLP mirrors not being constrained to be on the same plane. In the embodiment illustrated in FIG. 9, the DLP mirrors are tilted so that they form rows of DLP mirrors that share common planes. In the embodiment illustrated in FIG. 29, the individual DLP mirrors are not accurately positioned to be in the same plane since they are not in contact with the substrate. Examples of advantages of the embodiments associated with FIG. 29 are: first, the camera 2980 can be located between the DLP 2955 and the illumination light source 2958 to provide a more compact upper module 202. Second, the polarization state of the light reflected from the eye 2971 can be the same as that of the image light 2969 so that the optical path of the light reflected from the eye and the image light can be the same in the lower module 204.

[0200] FIG. 30 shows an illustration of an embodiment for displaying images to the wearer and simultaneously capturing images of the wearer’s eye, wherein light from the eye 2971 is reflected towards a camera 3080 by the partially reflective layer 2960. The partially reflective layer 2960 can be an optically flat layer such that the wavefront of the light from the eye 2971 is preserved and as a result, higher quality images of the wearer’s eye can be captured. In addition, since the DLP 2955 is not included in the optical path for the light from the eye 2971, and the eye imaging process shown in FIG. 30 does not interfere with the displayed image, images of the wearer’s eye can be captured independently (e.g. with independent of timing, impact on resolution, or pixel count used in the image light) from the displayed images.

[0201] In the embodiment illustrated in FIG. 30, the partially reflective layer 2960 is a reflective polarizer, the illuminating light 2973 is polarized, the light from the eye 2971 is polarized and the camera 3080 is located behind a polarizer 3085. The polarization axis of the illuminating light 2973 and the polarization axis of the light from the eye are oriented perpendicular to the transmission axis of the reflective polarizer so that they are both substantially reflected by the reflective polarizer. The illumination light 2973 passes through a quarter wave layer 2957 before being reflected by the DLP mirrors in the DLP 2955. The reflected light passes back through the quarter wave layer 2957 so that the polarization states of the image light 2969 and dark light 2975 are reversed in comparison to the illumination light 2973. As such, the image light 2969 and dark light 2975 are substantially transmitted by the reflective polarizer. Where the DLP mirrors in the “on” state provide the image light 2969 along an optical axis that extends into the lower optical module 204 to display an image to the wearer. At the same time, DLP mirrors in the “off” state provide the dark light 2975 along an optical axis that extends to the side of the upper optics module 202. In the region of the corrective wedge 2966 where the dark light 2975 is incident on the side of the upper optics module 202, an absorptive polarizer 3085 is positioned with its transmission axis perpendicular to the polarization axis of the dark light and parallel to the polarization axis of the light from the eye so that the dark light 2975 is absorbed and the light from the eye 2971 is transmitted to the camera 3080.

[0202] FIG. 31 shows an illustration of another embodiment of a system for displaying images and simultaneously capturing image of the wearer’s eye that is similar to the one shown in FIG. 30. The difference in the system shown in FIG. 31 is that the light from the eye 2971 is subjected to multiple reflections before being captured by the camera 3180. To enable the multiple reflections, a mirror 3187 is provided behind the absorptive polarizer 3185. Therefore, the light from the eye 2971 is polarized prior to entering the corrective wedge 2966 with a polarization axis that is perpendicular to the transmission axis of the reflective polarizer that comprises the partially reflective layer 2960. In this way, the light from the eye 2971 is reflected first by the reflective polarizer, reflected second by the mirror 3187 and reflected third by the reflective polarizer before being captured by the camera 3180. While the light from the eye 2971 passes through the absorptive polarizer 3185 twice, since the polarization axis of the light from the eye 2971 is oriented parallel to the polarization axis of the light from the eye 2971, it is substantially transmitted by the absorptive polarizer 3185. As with the system described in connection with FIG. 30, the system shown in FIG. 31 includes an optically flat partially reflective layer 2960 that preserves the wavefront of the light from the eye 2971 so that higher quality images of the wearer’s eye can be captured. Also, since the DLP 2955 is not included in the optical path for the light reflected from the eye 2971 and the eye imaging process shown in FIG. 31 does not interfere with the displayed image, images of the wearer’s eye can be captured independently from the displayed images.

[0203] FIG. 32 shows an illustration of a system for displaying images and simultaneously capturing images of the wearer’s eye that includes a beam splitter plate 3212 comprised of a reflective polarizer, which is held in air between the light source 2958, the DLP 2955 and the camera

3280. The illumination light 2973 and the light from the eye 2971 are both polarized with polarization axes that are perpendicular to the transmission axis of the reflective polarizer. As a result, both the illumination light 2973 and the light from the eye 2971 are substantially reflected by the reflective polarizer. The illumination light 2873 is reflected toward the DLP 2955 by the reflective polarizer and split into image light 2969 and dark light 3275 depending on whether the individual DLP mirrors are respectively in the “on” state or the “off” state. By passing through the quarter wave layer 2957 twice, the polarization state of the illumination light 2973 is reversed in comparison to the polarization state of the image light 2969 and the dark light 3275. As a result, the image light 2969 and the dark light 3275 are then substantially transmitted by the reflective polarizer. The absorptive polarizer 3285 at the side of the beam splitter plate 3212 has a transmission axis that is perpendicular to the polarization axis of the dark light 3275 and parallel to the polarization axis of the light from the eye 2971 so that the dark light 3275 is absorbed and the light from the eye 2971 is transmitted to the camera 3280. As in the system shown in FIG. 30, the system shown in FIG. 31 includes an optically flat beam splitter plate 3212 that preserves the wavefront of the light from the eye 2971 so that higher quality images of the wearer’s eye can be captured. Also, since the DLP 2955 is not included in the optical path for the light from the eye 2971 and the eye imaging process shown in FIG. 31 does not interfere with the displayed image, images of the wearer’s eye can be captured independently from the displayed images.

[0204] Eye imaging systems where the polarization state of the light from the eye 2971 needs to be opposite to that of the image light 2969 (as shown in FIGS. 30, 31 and 32), need to be used with lower modules 204 that include combiners that will reflect both polarization states. As such, these upper modules 202 are best suited for use with the lower modules 204 that include combiners that are reflective regardless of polarization state, examples of these lower modules are shown in FIGS. 6, 8a, 8b, 8c and 24-27.

[0205] In a further embodiment shown in FIG. 33, the partially reflective layer 3360 is comprised of a reflective polarizer on the side facing the illumination light 2973 and a short pass dichroic mirror on the side facing the light from the eye 3371 and the camera 3080. Where the short pass dichroic mirror is a dielectric mirror coating that transmits visible light and reflects infrared light. The partially reflective layer 3360 can be comprised of a reflective polarizer bonded to the inner surface of the illumination wedge 2964 and a short pass dielectric mirror coating on the opposing inner surface of the corrective wedge 2966, wherein the illumination wedge 2964 and the corrective wedge 2966 are then optically bonded together. Alternatively, the partially reflective layer 3360 can be comprised of a thin substrate that has a reflective polarizer bonded to one side and a short pass dichroic mirror coating on the other side, where the partially reflective layer 3360 is then bonded between the illumination wedge 2964 and the corrective wedge 2966. In this embodiment, an infrared light is included to illuminate the eye so that the light from the eye and the images captured of the eye are substantially comprised of infrared light. The wavelength of the infrared light is then matched to the reflecting wavelength of the shortpass dichroic mirror and the wavelength that the camera can capture images, for example an 800 nm wavelength can be used. In this way, the

short pass dichroic mirror transmits the image light and reflects the light from the eye. The camera 3080 is then positioned at the side of the corrective wedge 2966 in the area of the absorbing light trap 3382, which is provided to absorb the dark light 2975. By positioning the camera 3080 in a depression in the absorbing light trap 3382, scattering of the dark light 2975 by the camera 3080 can be reduced so that higher contrast images can be displayed to the wearer. An advantage of this embodiment is that the light from the eye need not be polarized, which can simplify the optical system and increase efficiency for the eye imaging system.

[0206] In yet another embodiment shown in FIG. 32a a beam splitter plate 3222 is comprised of a reflective polarizer on the side facing the illumination light 2973 and a short pass dichroic mirror on the side facing the light from the eye 3271 and the camera 3280. An absorbing surface 3295 is provided to trap the dark light 3275 and the camera 3280 is positioned in an opening in the absorbing surface 3295. In this way the system of FIG. 32 can be made to function with unpolarized light from the eye 3271.

[0207] In embodiments directed to capturing images of the wearer's eye, light to illuminate the wearer's eye can be provided by several different sources including: light from the displayed image (i.e. image light); light from the environment that passes through the combiner or other optics; light provided by a dedicated eye light, etc. FIGS. 34 and 34a show illustrations of dedicated eye illumination lights 3420. FIG. 34 shows an illustration from a side view in which the dedicated illumination eye light 3420 is positioned at a corner of the combiner 3410 so that it doesn't interfere with the image light 3415. The dedicated eye illumination light 3420 is pointed so that the eye illumination light 3425 illuminates the eyebox 3427 where the eye 3430 is located when the wearer is viewing displayed images provided by the image light 3415. FIG. 34a shows an illustration from the perspective of the eye of the wearer to show how the dedicated eye illumination light 3420 is positioned at the corner of the combiner 3410. While the dedicated eye illumination light 3420 is shown at the upper left corner of the combiner 3410, other positions along one of the edges of the combiner 3410, or other optical or mechanical components, are possible as well. In other embodiments, more than one dedicated eye light 3420 with different positions can be used. In an embodiment, the dedicated eye light 3420 is an infrared light that is not visible by the wearer (e.g. 800 nm) so that the eye illumination light 3425 doesn't interfere with the displayed image perceived by the wearer.

[0208] FIG. 35 shows a series of illustrations of captured eye images that show the eye glint (i.e. light that reflects off the front of the eye) produced by a dedicated eye light. In this embodiment of the disclosure, captured images of the wearer's eye are analyzed to determine the relative positions of the iris 3550, pupil, or other portion of the eye, and the eye glint 3560. The eye glint is a reflected image of the dedicated eye light 3420 when the dedicated light is used. FIG. 35 illustrates the relative positions of the iris 3550 and the eye glint 3560 for a variety of eye positions. By providing a dedicated eye light 3420 in a fixed position, combined with the fact that the human eye is essentially spherical, or at least a reliably repeatable shape, the eye glint provides a fixed reference point against which the determined position of the iris can be compared to determine where the wearer is looking, either within the displayed

image or within the see-through view of the surrounding environment. By positioning the dedicated eye light 3420 at a corner of the combiner 3410, the eye glint 3560 is formed away from the iris 3550 in the captured images. As a result, the positions of the iris and the eye glint can be determined more easily and more accurately during the analysis of the captured images, since they do not interfere with one another. In a further embodiment, the combiner includes an associated cut filter that prevents infrared light from the environment from entering the HWC and the camera is an infrared camera, so that the eye glint is only provided by light from the dedicated eye light. For example, the combiner can include a low pass filter that passes visible light while absorbing infrared light and the camera can include a high pass filter that absorbs visible light while passing infrared light.

[0209] In an embodiment of the eye imaging system, the lens for the camera is designed to take into account the optics associated with the upper module 202 and the lower module 204. This is accomplished by designing the camera to include the optics in the upper module 202 and optics in the lower module 204, so that a high MTF image is produced, at the image sensor in the camera, of the wearer's eye. In yet a further embodiment, the camera lens is provided with a large depth of field to eliminate the need for focusing the camera to enable sharp image of the eye to be captured. Where a large depth of field is typically provided by a high $f/\#$ lens (e.g. $f/\# > 5$). In this case, the reduced light gathering associated with high $f/\#$ lenses is compensated by the inclusion of a dedicated eye light to enable a bright image of the eye to be captured. Further, the brightness of the dedicated eye light can be modulated and synchronized with the capture of eye images so that the dedicated eye light has a reduced duty cycle and the brightness of infrared light on the wearer's eye is reduced.

[0210] In a further embodiment, FIG. 36a shows an illustration of an eye image that is used to identify the wearer of the HWC. In this case, an image of the wearer's eye 3611 is captured and analyzed for patterns of identifiable features 3612. The patterns are then compared to a database of eye images to determine the identity of the wearer. After the identity of the wearer has been verified, the operating mode of the HWC and the types of images, applications, and information to be displayed, can be adjusted and controlled in correspondence to the determined identity of the wearer. Examples of adjustments to the operating mode depending on who the wearer is determined to be or not be include: making different operating modes or feature sets available, shutting down or sending a message to an external network, allowing guest features and applications to run, etc.

[0211] FIG. 36b is an illustration of another embodiment using eye imaging, in which the sharpness of the displayed image is determined based on the eye glint produced by the reflection of the displayed image from the wearer's eye surface. By capturing images of the wearer's eye 3611, an eye glint 3622, which is a small version of the displayed image can be captured and analyzed for sharpness. If the displayed image is determined to not be sharp, then an automated adjustment to the focus of the HWC optics can be performed to improve the sharpness. This ability to perform a measurement of the sharpness of a displayed image at the surface of the wearer's eye can provide a very accurate measurement of image quality. Having the ability to measure and automatically adjust the focus of displayed images can

be very useful in augmented reality imaging where the focus distance of the displayed image can be varied in response to changes in the environment or changes in the method of use by the wearer.

[0212] An aspect of the present disclosure relates to controlling the HWC 102 through interpretations of eye imagery. In embodiments, eye-imaging technologies, such as those described herein, are used to capture an eye image or series of eye images for processing. The image(s) may be processed to determine a user intended action, an HWC predetermined reaction, or other action. For example, the imagery may be interpreted as an affirmative user control action for an application on the HWC 102. Or, the imagery may cause, for example, the HWC 102 to react in a predetermined way such that the HWC 102 is operating safely, intuitively, etc.

[0213] FIG. 37 illustrates a eye imagery process that involves imaging the HWC 102 wearer's eye(s) and processing the images (e.g. through eye imaging technologies described herein) to determine in what position 3702 the eye is relative to its neutral or forward looking position and/or the FOV 3708. The process may involve a calibration step where the user is instructed, through guidance provided in the FOV of the HWC 102, to look in certain directions such that a more accurate prediction of the eye position relative to areas of the FOV can be made. In the event the wearer's eye is determined to be looking towards the right side of the FOV 3708 (as illustrated in FIG. 37, the eye is looking out of the page) a virtual target line may be established to project what in the environment the wearer may be looking towards or at. The virtual target line may be used in connection with an image captured by camera on the HWC 102 that images the surrounding environment in front of the wearer. In embodiments, the field of view of the camera capturing the surrounding environment matches, or can be matched (e.g. digitally), to the FOV 3708 such that making the comparison is made more clear. For example, with the camera capturing the image of the surroundings in an angle that matches the FOV 3708 the virtual line can be processed (e.g. in 2d or 3d, depending on the camera images capabilities and/or the processing of the images) by projecting what surrounding environment objects align with the virtual target line. In the event there are multiple objects along the virtual target line, focal planes may be established corresponding to each of the objects such that digital content may be placed in an area in the FOV 3708 that aligns with the virtual target line and falls at a focal plane of an intersecting object. The user then may see the digital content when he focuses on the object in the environment, which is at the same focal plane. In embodiments, objects in line with the virtual target line may be established by comparison to mapped information of the surroundings.

[0214] In embodiments, the digital content that is in line with the virtual target line may not be displayed in the FOV until the eye position is in the right position. This may be a predetermined process. For example, the system may be set up such that a particular piece of digital content (e.g. an advertisement, guidance information, object information, etc.) will appear in the event that the wearer looks at a certain object(s) in the environment. A virtual target line(s) may be developed that virtually connects the wearer's eye with an object(s) in the environment (e.g. a building, portion of a building, mark on a building, gps location, etc.) and the virtual target line may be continually updated depending on

the position and viewing direction of the wearer (e.g. as determined through GPS, e-compass, IMU, etc.) and the position of the object. When the virtual target line suggests that the wearer's pupil is substantially aligned with the virtual target line or about to be aligned with the virtual target line, the digital content may be displayed in the FOV 3704.

[0215] In embodiments, the time spent looking along the virtual target line and/or a particular portion of the FOV 3708 may indicate that the wearer is interested in an object in the environment and/or digital content being displayed. In the event there is no digital content being displayed at the time a predetermined period of time is spent looking at a direction, digital content may be presented in the area of the FOV 3708. The time spent looking at an object may be interpreted as a command to display information about the object, for example. In other embodiments, the content may not relate to the object and may be presented because of the indication that the person is relatively inactive. In embodiments, the digital content may be positioned in proximity to the virtual target line, but not in-line with it such that the wearer's view of the surroundings are not obstructed but information can augment the wearer's view of the surroundings. In embodiments, the time spent looking along a target line in the direction of displayed digital content may be an indication of interest in the digital content. This may be used as a conversion event in advertising. For example, an advertiser may pay more for an add placement if the wearer of the HWC 102 looks at a displayed advertisement for a certain period of time. As such, in embodiments, the time spent looking at the advertisement, as assessed by comparing eye position with the content placement, target line or other appropriate position may be used to determine a rate of conversion or other compensation amount due for the presentation.

[0216] An aspect of the disclosure relates to removing content from the FOV of the HWC 102 when the wearer of the HWC 102 apparently wants to view the surrounding environments clearly. FIG. 38 illustrates a situation where eye imagery suggests that the eye has or is moving quickly so the digital content 3804 in the FOV 3808 is removed from the FOV 3808. In this example, the wearer may be looking quickly to the side indicating that there is something on the side in the environment that has grabbed the wearer's attention. This eye movement 3802 may be captured through eye imaging techniques (e.g. as described herein) and if the movement matches a predetermined movement (e.g. speed, rate, pattern, etc.) the content may be removed from view. In embodiments, the eye movement is used as one input and HWC movements indicated by other sensors (e.g. IMU in the HWC) may be used as another indication. These various sensor movements may be used together to project an event that should cause a change in the content being displayed in the FOV.

[0217] In embodiments, to remove the entire displayed image from the FOV and thereby provide an unencumbered view of the surrounding environment, power to the light source is turned OFF while power to the electronics in the HWC is left ON. As a result, the entire displayed image disappears instantly but the electronics associated with displaying images continues to run so that when eye movement or other triggering event occurs, a displayed image can be instantly provided without having to wait for the electronics to reboot. By turning the light source OFF and ON, to make

the displayed image respectively disappear and then reappear, rapid changes between a display mode and a see-through mode can be provided. In an example, a rapid eye movement to the side as captured by eye imaging can cause the light source to turn OFF thereby providing an unencumbered view of the environment. Later when the eye returns to a central position, the light source may be turned ON so the displayed image returns. In another example, a rapid eye movement or rapid head nod by the wearer can be used in an operating mode to cause the light source to be turned OFF to obtain an unencumbered view of the environment for a predetermined period of time. After the predetermined period of time, the light source is turned ON and the displayed image is returned.

[0218] Another aspect of the present disclosure relates to determining a focal plane based on the wearer's eye convergence. Eyes are generally converged slightly and converge more when the person focuses on something very close. This is generally referred to as convergence. In embodiments, convergence is calibrated for the wearer. That is, the wearer may be guided through certain focal plane exercises to determine how much the wearer's eyes converge at various focal planes and at various viewing angles. The convergence information may then be stored in a database for later reference. In embodiments, a general table may be used in the event there is no calibration step or the person skips the calibration step. The two eyes may then be imaged periodically to determine the convergence in an attempt to understand what focal plane the wearer is focused on. In embodiments, the eyes may be imaged to determine a virtual target line and then the eye's convergence may be determined to establish the wearer's focus, and the digital content may be displayed or altered based thereon.

[0219] FIG. 39 illustrates a situation where digital content is moved 3902 within one or both of the FOVs 3908 and 3910 to align with the convergence of the eyes as determined by the pupil movement 3904. By moving the digital content to maintain alignment, in embodiments, the overlapping nature of the content is maintained so the object appears properly to the wearer. This can be important in situations where 3D content is displayed.

[0220] An aspect of the present disclosure relates to controlling the HWC 102 based on events detected through eye imaging. A wearer winking, blinking, moving his eyes in a certain pattern, etc. may, for example, control an application of the HWC 102. Eye imaging (e.g. as described herein) may be used to monitor the eye(s) of the wearer and once a pre-determined pattern is detected an application control command may be initiated.

[0221] An aspect of the disclosure relates to monitoring the health of a person wearing a HWC 102 by monitoring the wearer's eye(s). Calibrations may be made such that the normal performance, under various conditions (e.g. lighting conditions, image light conditions, etc.) of a wearer's eyes may be documented. The wearer's eyes may then be monitored through eye imaging (e.g. as described herein) for changes in their performance. Changes in performance may be indicative of a health concern (e.g. concussion, brain injury, stroke, loss of blood, etc.). If detected the data indicative of the change or event may be communicated from the HWC 102.

[0222] Aspects of the present disclosure relate to security and access of computer assets (e.g. the HWC itself and related computer systems) as determined through eye image

verification. As discussed herein elsewhere, eye imagery may be compared to known person eye imagery to confirm a person's identity. Eye imagery may also be used to confirm the identity of people wearing the HWCs 102 before allowing them to link together or share files, streams, information, etc.

[0223] An aspect of the present disclosure relates to securely linking HWC 102 and securely sharing files, streams, etc. (referred to generally as file sharing) with other HWC's 102 and/or other computers. Eye imaging, position, and tracking described herein elsewhere may be used in connection with the secure linking and file sharing. For example, a first HWC 102 may only be permitted to securely link with another HWC 102 if the wearer of the other HWC 102 is verified as a known person of a certain security level. In embodiments, the security level may be a government determined security level, a known person, a known friend, etc. Eye imaging may be used to identify the other HWCs 102 that may be allowed for sharing. For example, GPS or other location technologies may be used to identify other HWC's 102 in the proximity of a first HWC 102 and those proximal HWC's may be sorted into ones verified as secure HWC's, as verified by eye imaging, for example, and ones not verified. The sorted information or portion thereof may be presented in the first HWC 102 such that the wearer of the first HWC 102 can select secure sharing partners. Other sensor information may be used in connection with the secure sharing process. For example, identifying that two HWC's 102 are looking at one another (e.g. through e-compass readings, or HWC 102 forward facing camera image capture processing, etc.) may indicate that the two would like to share files or otherwise link communications and this information may be used in connection with the eye imaging verification for the secure sharing process. Similarly, facial recognition, biometric information (e.g. heart rate signature, lung signature, etc.), near field communication identification, gestures by and between people wearing the HWC's, external user interfaces, voice commands, voice signatures, light emission signatures/signals, wireless communication signals (e.g. encrypted signals/commands), etc. may be used in combination with eye imaging and each other as a way of identifying potential secure share partners and sharing. In the event secure share partner(s) are identified, linking may be done automatically or through a user interface action, for example. In the event a user action is required, the display in the HWC 102 may display indications of who is a potential secure share partner by presented the indications on a map, through AR, or otherwise. The AR interface may involve presenting the indication in at positions in the field of view of the HWC 102 that are indicative of a GPS location of the potential secure sharing partner (as described herein elsewhere). For further information on secure linking and file sharing see U.S. patent application Ser. No. 14/181,473, entitled Secure Sharing in Head Worn Computing, filed Feb. 14, 2014, which is hereby incorporated by reference herein in its entirety.

[0224] Another aspect of the present disclosure relates to presentation techniques relating to the presentation of a known location or person or object at the known location. In embodiments, a spatially three-dimensional target line may be established between a first HWC 102 and a known geo-spatial location (e.g. as described by a gps location or other triangulation technology). Digital content may then be presented in a position in the field of view of the HWC 102

that corresponds, or is in-line, with the target line. The digital content may further be presented such that it comes into the wearer's view when the wearer focuses on a particular focal plane in the distance. The focal plane could then be aligned with the geo-spatial location such that when the wearer looks at the geo-spatial location, which is in-line with the target line, the digital content will come into view for the wearer and indicate the location with a proper visual perspective. In embodiments, the perceived environmental position indicative of the geo-spatial location may be verified by comparing the distance and angle defined by the virtual target line with a distance and angle measured by a range finder. This may be done to confirm that there are no obstacles in between the wearer of the HWC **102** and the geo-spatial location, for example. In the event that the verification indicates that there is an obstacle and that the geo-spatial location cannot be directly viewed, the digital content indicative of the location may be altered to indicate that the location is obstructed. The digital content may indicate if the location is in close proximity to the obstruction, far from the obstruction, etc. For further information on geo-spatial position visualizations see U.S. patent application Ser. No. 14/205,313 entitled Spatial Location Presentation in Head Worn Computing, filed Mar. 11, 2014, which is hereby incorporated by reference herein in its entirety.

[0225] An aspect of the present disclosure relates to presenting digital content in a field of view of a see-through head worn optical system at a position that is dependent on feedback from a sensor. In embodiments, the sensor provides information relating to a speed of forward motion of a person wearing the see-through head worn optical system. In embodiments, the content may be shifted to a portion of the FOV that provides for greater see-through visibility for the wearer. For example, if the wearer is walking, the content may be shifted towards the edge of the FOV so the person can focus on the surrounding environment while walking but still be able to view the content at the edges of the FOV. In other embodiments, the person may be moving very fast, driving a car, for example, and the content may be shifted even further towards the edge of the FOV, or even past the FOV such that the person can more intently focus on the environment. In embodiments, when the content is shifted beyond the FOV, the content may be removed from display entirely and it may re-appear when an indication is presented that the wearer wants to view it or that the motion has slowed. For example, the wearer may use an external UI, gesture eye control command, etc. to cause the content to come back into the FOV. In embodiments, the wearer may be able to affirmatively cause the content to be moved to a location in the FOV dependent on his needs and this may modify or over-ride the content position shift based on the person's movement speed. For example, if the wearer is driving a car and the car is moving quickly, the wearer may choose to have the content displayed closer to the middle of the FOV and over-ride the auto-shift content position function.

[0226] When a user is moving through an environment while wearing a head worn computer, the method in which information is displayed may differ depending on a variety of factors that describe the way in which the user is moving. Factors such as speed, gaze direction, rate of change of gaze direction, rate of change of movement direction and the type of information being displayed may all affect how the user wants the information to be displayed.

[0227] In describing the method of display when moving, the pertinent information includes the heading that the user is looking along (generally referred to herein as "sight heading" or "sight vector"), the heading that the user is moving along (generally referred to herein as "movement heading" or "movement vector") and the heading where the displayed information is visible by the user (generally referred to herein as "display heading" or "display vector"). Where headings are described in term of degrees as measured, for example, with a compass. Sight heading can be determined, for example, with an electronic compass or magnetometer in the HWC. Movement heading can be determined by multiple GPS readings, IMU readings, etc.

[0228] A method of presenting content is to provide the displayed information directly in front of the user all the time. In this case, the sight heading is the same as the display heading. This method can be less than ideal when the user is moving because the displayed information interferes with the view of the surrounding environment. With a see-through HWC, there can be times when the user would prefer to be provided with an unencumbered view of the environment. As such, there will be times when the user would prefer to not have displayed information in the see-through field of view. In embodiments, the process adjusts the display heading in response to the sight heading, movement heading and speed of movement. In further embodiments the method of the disclosure adjusts the display heading based on the type of information being displayed and in response to the sight heading, movement heading and speed of movement. In yet other embodiments, the method adjusts the display heading in response to indications of how the user is moving. In further embodiments, the brightness of the displayed image is reduced in response to the sight heading, movement heading and speed of movement.

[0229] Another example of when a user may not want to have displayed information presented in the see-through field of view is when some type of stimulus occurs in the adjacent vicinity such as a loud noise to the side of the user. Typically people respond to loud noises by turning their head to look toward the loud noise. At that point in time, the user would prefer to have an unencumbered view of the environment and, in embodiments, the content is removed based on the sound received at the HWC.

[0230] In another example, the user moves through an environment at various speeds. When a person is stationary, the person can look in any direction so the sight heading can change, but the movement heading doesn't change because there is no movement. If a person is walking, the person can look back and forth while moving, as such the sight heading can vary on either side of the movement heading and the sight heading can vary slowly. As the speed increases, it becomes more difficult for the person to look to the side for long periods of time so the sight heading can change more rapidly as the person glances to the side and in general the sight heading is more likely to match the movement heading. At high speed, such as running, the person needs to look directly ahead most of the time, so the sight heading matches the movement heading most of the time. When in a vehicle traveling at even greater speed, the person can only look briefly to the side when driving and most of the time must look ahead at the road where the sight heading matches the movement heading with only brief departures. Of course when the person is riding in a vehicle but not driving the

vehicle, the person can look sideways for extended periods of time, as a result the sight heading can vary substantially from the movement heading.

[0231] FIG. 45 shows an example set of data for a person moving through an environment over a path that starts with a movement heading of 0 degrees and ends with a movement heading of 114 degrees during which time the speed of movement varies from 0 m/sec to 20 m/sec. The sight heading can be seen to vary on either side of the movement heading while moving as the person looks from side to side. Large changes in sight heading occur when the movement speed is 0 m/sec when the person is standing still, followed by step changes in movement heading.

[0232] Embodiments provide a process for determining the display heading that takes into account the way a user moves through an environment and provides a display heading that makes it easy for the user to find the displayed information while also providing unencumbered see-through views of the environment in response to different movements, speed of movement or different types of information being displayed.

[0233] FIG. 46 illustrates a see-through view as may be seen when using a HWC wherein information is overlaid onto a see-through view of the environment. The tree and the building are actually in the environment and the text is displayed in the see-through display such that it appears overlaid on the environment. In addition to text information such as, for example, instructions and weather information, some augmented reality information is shown that relates to nearby objects in the environment.

[0234] In an embodiment, the display heading is determined based on speed of movement. At low speeds, the display heading may be substantially the same as the sight heading while at high speed the display heading may be substantially the same as the movement heading. In embodiments, as long as the user remains stationary, the displayed information is presented directly in front of the user and HWC. However, as the movement speed increases (e.g. above a threshold or continually, etc.) the display heading becomes substantially the same as the movement heading regardless of the direction the user is looking, so that when the user looks in the direction of movement, the displayed information is directly in front of the user and HMD and when the user looks to the side the displayed information is not visible.

[0235] Rapid changes in sight heading can be followed by a slower change in the display heading to provide a damped response to head rotation. Alternatively, the display heading can be substantially the time averaged sight heading so that the displayed information is presented at a heading that is in the middle of a series of sight headings over a period of time. In this embodiment, if the user stops moving their head, the display heading gradually becomes the same as the sight heading and the displayed information moves into the display field of view in front of the user and HMD. In embodiments, when there is a high rate of sight heading change, the process delays the effect of the time averaged sight heading on the display heading. In this way, the effect of rapid head movements on display heading is reduced and the positioning of the displayed information within the display field of view is stabilized laterally.

[0236] In another embodiment, display heading is determined based on speed of movement where at high-speed, the display heading is substantially the same as the movement

heading. At mid-speed the display heading is substantially the same as a time averaged sight heading so that rapid head rotations are damped out and the display heading is in the middle of back and forth head movements.

[0237] In yet another embodiment, the type of information being displayed is included in determining how the information should be displayed. Augmented reality information that is connected to objects in the environment is given a display heading that substantially matches the sight heading. In this way, as the user rotates their head, augmented reality information comes into view that is related to objects that are in the see-through view of the environment. At the same time, information that is not connected to objects in the environment is given a display heading that is determined based on the type of movements and speed of movements as previously described in this specification.

[0238] In yet a further embodiment, when the speed of movement is determined to be above a threshold, the information displayed is moved downward in the display field of view so that the upper portion of the display field of view has less information or no information displayed to provide the user with an unencumbered see-through view of the environment.

[0239] FIGS. 47 and 48 show illustrations of a see-through view including overlaid displayed information. FIG. 47 shows the see-through view immediately after a rapid change in sight heading from the sight heading associated with the see-through view shown in FIG. 46 wherein the change in sight heading comes from a head rotation. In this case, the display heading is delayed. FIG. 48 shows how at a later time, the display heading catches up to the sight heading. The augmented reality information remains in positions within the display field of view where the association with objects in the environment can be readily made by the user.

[0240] FIG. 49 shows an illustration of a see-through view example including overlaid displayed information that has been shifted downward in the display field of view to provide an unencumbered see-through view in the upper portion of the see-through view. At the same time, augmented reality labels have been maintained in locations within the display field of view so they can be readily associated with objects in the environment.

[0241] In embodiments, the content may be positioned with respect to other types of sensors. For example, a sensor may detect an environmental condition that may be of interest and this may affect the position of the content in the display. For example, the sensor may be a chemical sensor, fire sensor, mechanical sensor, electrical sensor, audio sensor, biologic sensor, etc. and the sensor may detect the presence of danger or other condition that causes the wearer to want to view the surroundings in a clear view so the content may then shift in or out of the field of view, as described herein. In embodiments, the sensor(s) may be mounted on/in the HWC 102, local to the HWC 102, remote from the HWC 102, or otherwise located. In embodiments, the sensor input may cause content to be presented in the field of view and then the sensor input, from the same or a different sensor or combination of sensors, may cause the content to be re-positioned.

[0242] FIG. 40 illustrates an embodiment in which digital content presented in a see-through FOV is positioned based on the speed in which the wearer is moving. When the person is not moving, as measured by sensor(s) in the HWC

102 (e.g. IMU, GPS based tracking, etc.), digital content may be presented at the stationary person content position **4004**. The content position **4004** is indicated as being in the middle of the see-through FOV **4002**; however, this is meant to illustrate that the digital content is positioned within the see-through FOV at a place that is generally desirable knowing that the wearer is not moving and as such the wearer's surrounding see through view can be somewhat obstructed. So, the stationary person content position, or neutral position, may not be centered in the see-through FOV; it may be positioned somewhere in the see-through FOV deemed desirable and the sensor feedback may shift the digital content from the neutral position. The movement of the digital content for a quickly moving person is also shown in FIG. **40** wherein as the person turns their head to the side, the digital content moves out of the see-through FOV to content position **4008** and then moves back as the person turns their head back. For a slowly moving person, the head movement can be more complex and as such the movement of the digital content in an out of the see-through FOV can follow a path such as that shown by content position **4010**.

[0243] In embodiments, the sensor that assesses the wearer's movements may be a GPS sensor, IMU, accelerometer, etc. The content position may be shifted from a neutral position to a position towards a side edge of the field of view as the forward motion increases. The content position may be shifted from a neutral position to a position towards a top or bottom edge of the field of view as the forward motion increases. The content position may shift based on a threshold speed of the assessed motion. The content position may shift linearly based on the speed of the forward motion. The content position may shift non-linearly based on the speed of the forward motion. The content position may shift outside of the field of view. In embodiments, the content is no longer displayed if the speed of movement exceeds a predetermined threshold and will be displayed again once the forward motion slows.

[0244] In embodiments, the content position may generally be referred to as shifting; it should be understood that the term shifting encompasses a process where the movement from one position to another within the see-through FOV or out of the FOV is visible to the wearer (e.g. the content appears to slowly or quickly move and the user perceives the movement itself) or the movement from one position to another may not be visible to the wearer (e.g. the content appears to jump in a discontinuous fashion or the content disappears and then reappears in the new position).

[0245] Another aspect of the present disclosure relates to removing the content from the field of view or shifting it to a position within the field of view that increases the wearer's view of the surrounding environment when a sensor causes an alert command to be issued. In embodiments, the alert may be due to a sensor or combination of sensors that sense a condition above a threshold value. For example, if an audio sensor detects a loud sound of a certain pitch, content in the field of view may be removed or shifted to provide a clear view of the surrounding environment for the wearer. In addition to the shifting of the content, in embodiments, an indication of why the content was shifted may be presented in the field of view or provided through audio feedback to the wearer. For instance, if a carbon monoxide sensor detects a high concentration in the area, content in the field of view may be shifted to the side of the field of view or removed

from the field of view and an indication may be provided to the wearer that there is a high concentration of carbon monoxide in the area. This new information, when presented in the field of view, may similarly be shifted within or outside of the field of view depending on the movement speed of the wearer.

[0246] FIG. **41** illustrates how content may be shifted from a neutral position **4104** to an alert position **4108**. In this embodiment, the content is shifted outside of the see-through FOV **4102**. In other embodiments, the content may be shifted as described herein.

[0247] Another aspect of the present disclosure relates to identification of various vectors or headings related to the HWC **102**, along with sensor inputs, to determine how to position content in the field of view. In embodiments, the speed of movement of the wearer is detected and used as an input for position of the content and, depending on the speed, the content may be positioned with respect to a movement vector or heading (i.e. the direction of the movement), or a sight vector or heading (i.e. the direction of the wearer's sight direction). For example, if the wearer is moving very fast the content may be positioned within the field of view with respect to the movement vector because the wearer is only going to be looking towards the sides of himself periodically and for short periods of time. As another example, if the wearer is moving slowly, the content may be positioned with respect to the sight heading because the user may more freely be shifting his view from side to side.

[0248] FIG. **42** illustrates two examples where the movement vector may effect content positioning. Movement vector A **4202** is shorter than movement vector B **4210** indicating that the forward speed and/or acceleration of movement of the person associated with movement vector A **4202** is lower than the person associated with movement vector B **4210**. Each person is also indicated as having a sight vector or heading **4208** and **4212**. The sight vectors A **4208** and B **4210** are the same from a relative perspective. The white area inside of the black triangle in front of each person is indicative of how much time each person likely spends looking at a direction that is not in line with the movement vector. The time spent looking off angle A **4204** is indicated as being more than that of the time spent looking off angle B **4214**. This may be because the movement vector speed A is lower than movement vector speed B. The faster the person moves forward the more the person tends to look in the forward direction, typically. The FOVs A **4218** and B **4222** illustrate how content may be aligned depending on the movement vectors **4202** and **4210** and sight vectors **4208** and **4212**. FOV A **4218** is illustrated as presenting content in-line with the sight vector **4220**. This may be due to the lower speed of the movement vector A **4202**. This may also be due to the prediction of a larger amount of time spent looking off angle A **4204**. FOV B **4222** is illustrated as presenting content in line with the movement vector **4224**. This may be due to the higher speed of movement vector B **4210**. This may also be due to the prediction of a shorter amount of time spent looking off angle B **4214**.

[0249] Another aspect of the present disclosure relates to damping a rate of content position change within the field of view. As illustrated in FIG. **43**, the sight vector may undergo a rapid change **4304**. This rapid change may be an isolated event or it may be made at or near a time when other sight vector changes are occurring. The wearer's head may be

turning back and forth for some reason. In embodiments, the rapid successive changes in sight vector may cause a damped rate of content position change **4308** within the FOV **4302**. For example, the content may be positioned with respect to the sight vector, as described herein, and the rapid change in sight vector may normally cause a rapid content position change; however, since the sight vector is successively changing, the rate of position change with respect to the sight vector may be damped, slowed, or stopped. The position rate change may be altered based on the rate of change of the sight vector, average of the sight vector changes, or otherwise altered.

[0250] Another aspect of the present disclosure relates to simultaneously presenting more than one content in the field of view of a see-through optical system of a HWC **102** and positioning one content with the sight heading and one content with the movement heading. FIG. **44** illustrates two FOV's **A 4414** and **B 4420**, which correspond respectively to the two identified sight vectors **A 4402** and **B 4404**. FIG. **44** also illustrates an object in the environment **4408** at a position relative to the sight vectors **A 4402** and **B 4404**. When the person is looking along sight vector **A 4402**, the environment object **4408** can be seen through the field of view **A 4414** at position **4412**. As illustrated, sight heading aligned content is presented as TEXT in proximity with the environment object **4412**. At the same time, other content **4418** is presented in the field of view **A 4414** at a position aligned in correspondence with the movement vector. As the movement speed increases, the content **4418** may shift as described herein. When the sight vector of the person is sight vector **B 4404** the environmental object **4408** is not seen in the field of view **B 4420**. As a result, the sight aligned content **4410** is not presented in field of view **B 4420**; however, the movement aligned content **4418** is presented and is still dependent on the speed of the motion.

[0251] In a further embodiment, in an operating mode such as when the user is moving in an environment, digital content is presented at the side of the user's see-through FOV so that the user can only view the digital content by turning their head. In this case, when the user is looking straight ahead, such as when the movement heading matches the sight heading, the see-through view FOV does not include digital content. The user then accesses the digital content by turning their head to the side whereupon the digital content moves laterally into the user's see-through FOV. In another embodiment, the digital content is ready for presentation and will be presented if an indication for its presentation is received. For example, the information may be ready for presentation and if the sight heading or predetermined position of the HWC **102** is achieved the content may then be presented. The wearer may look to the side and the content may be presented. In another embodiment, the user may cause the content to move into an area in the field of view by looking in a direction for a predetermined period of time, blinking, winking, or displaying some other pattern that can be captured through eye imaging technologies (e.g. as described herein elsewhere).

[0252] In yet another embodiment, an operating mode is provided wherein the user can define sight headings wherein the associated see-through FOV includes digital content or does not include digital content. In an example, this operating mode can be used in an office environment where when the user is looking at a wall digital content is provided within the FOV, whereas when the user is looking toward a hallway,

the FOV is unencumbered by digital content. In another example, when the user is looking horizontally digital content is provided within the FOV, but when the user looks down (e.g. to look at a desktop or a cellphone) the digital content is removed from the FOV.

[0253] Another aspect of the present disclosure relates to collecting and using eye position and sight heading information. Head worn computing with motion heading, sight heading, and/or eye position prediction (sometimes referred to as "eye heading" herein) may be used to identify what a wearer of the HWC **102** is apparently interested in and the information may be captured and used. In embodiments, the information may be characterized as viewing information because the information apparently relates to what the wearer is looking at. The viewing information may be used to develop a personal profile for the wearer, which may indicate what the wearer tends to look at. The viewing information from several or many HWC's **102** may be captured such that group or crowd viewing trends may be established. For example, if the movement heading and sight heading are known, a prediction of what the wearer is looking at may be made and used to generate a personal profile or portion of a crowd profile. In another embodiment, if the eye heading and location, sight heading and/or movement heading are known, a prediction of what is being looked at may be predicted. The prediction may involve understanding what is in proximity of the wearer and this may be understood by establishing the position of the wearer (e.g. through GPS or other location technology) and establishing what mapped objects are known in the area. The prediction may involve interpreting images captured by the camera or other sensors associated with the HWC **102**. For example, if the camera captures an image of a sign and the camera is in-line with the sight heading, the prediction may involve assessing the likelihood that the wearer is viewing the sign. The prediction may involve capturing an image or other sensory information and then performing object recognition analysis to determine what is being viewed. For example, the wearer may be walking down a street and the camera that is in the HWC **102** may capture an image and a processor, either on-board or remote from the HWC **102**, may recognize a face, object, marker, image, etc. and it may be determined that the wearer may have been looking at it or towards it.

[0254] FIG. **50** illustrates a scene where a person is walking with a HWC **102** mounted on his head. In this scene, the person's geo-spatial location **5004** is known through a GPS sensor, which could be another location system, and his movement heading, sight heading **5014** and eye heading **5002** are known and can be recorded (e.g. through systems described herein). There are objects and a person in the scene. Person **5012** may be recognized by the wearer's HWC **102** system, the person may be mapped (e.g. the person's GPS location may be known or recognized), or otherwise known. The person may be wearing a garment or device that is recognizable. For example, the garment may be of a certain style and the HWC may recognize the style and record it's viewing. The scene also includes a mapped object **5018** and a recognized object **5020**. As the wearer moves through the scene, the sight and/or eye headings may be recorded and communicated from the HWC **102**. In embodiments, the time that the sight and/or eye heading maintains a particular position may be recorded. For example, if a person appears to look at an object or person

for a predetermined period of time (e.g. 2 seconds or longer), the information may be communicated as gaze persistence information as an indication that the person may have been interested in the object.

[0255] In embodiments, sight headings may be used in conjunction with eye headings or eye and/or sight headings may be used alone. Sight headings can do a good job of predicting what direction a wearer is looking because many times the eyes are looking forward, in the same general direction as the sight heading. In other situations, eye headings may be a more desirable metric because the eye and sight headings are not always aligned. In embodiments herein examples may be provided with the term “eye/sight” heading, which indicates that either or both eye heading and sight heading may be used in the example.

[0256] FIG. 51 illustrates a system for receiving, developing and using movement heading, sight heading, eye heading and/or persistence information from HWC(s) 102. The server 5104 may receive heading or gaze persistence information, which is noted as persistence information 5102, for processing and/or use. The heading and/or gaze persistence information may be used to generate a personal profile 5108 and/or a group profile 5110. The personal profile 5018 may reflect the wearer’s general viewing tendencies and interests. The group profile 5110 may be an assemblage of different wearer’s heading and persistence information to create impressions of general group viewing tendencies and interests. The group profile 5110 may be broken into different groups based on other information such as gender, likes, dislikes, biographical information, etc. such that certain groups can be distinguished from other groups. This may be useful in advertising because an advertiser may be interested in what a male adult sports go’er is generally looking at as oppose to a younger female. The profiles 5108 and 5110 and raw heading and persistence information may be used by retailers 5114, advertisers 5118, trainers, etc. For example, an advertiser may have an advertisement posted in an environment and may be interested in knowing how many people look at the advertisement, how long they look at it and where they go after looking at it. This information may be used as conversion information to assess the value of the advertisement and thus the payment to be received for the advertisement.

[0257] In embodiments, the process involves collecting eye and/or sight heading information from a plurality of head-worn computers that come into proximity with an object in an environment. For example, a number of people may be walking through an area and each of the people may be wearing a head worn computer with the ability to track the position of the wearer’s eye(s) as well as possibly the wearer’s sight and movement headings. The various HWC wearing individuals may then walk, ride, or otherwise come into proximity with some object in the environment (e.g. a store, sign, person, vehicle, box, bag, etc.). When each person passes by or otherwise comes near the object, the eye imaging system may determine if the person is looking towards the object. All of the eye/sight heading information may be collected and used to form impressions of how the crowd reacted to the object. A store may be running a sale and so the store may put out a sign indicating such. The storeowners and managers may be very interested to know if anyone is looking at their sign. The sign may be set as the object of interest in the area and as people navigate near the sign, possibly determined by their GPS locations, the eye/

sight heading determination system may record information relative to the environment and the sign. Once, or as, the eye/sight heading information is collected and associations between the eye headings and the sign are determined, feedback may be sent back to the storeowner, managers, advertiser, etc. as an indication of how well their sign is attracting people. In embodiments, the sign’s effectiveness at attracting people’s attention, as indicated through the eye/sight headings, may be considered a conversion metric and impact the economic value of the sign and/or the signs placement.

[0258] In embodiments, a map of the environment with the object may be generated by mapping the locations and movement paths of the people in the crowd as they navigate by the object (e.g. the sign). Layered on this map may be an indication of the various eye/sight headings. This may be useful in indicating wear people were in relation to the object when then viewed they object. The map may also have an indication of how long people looked at the object from the various positions in the environment and where they went after seeing the object.

[0259] In embodiments, the process involves collecting a plurality of eye/sight headings from a head-worn computer, wherein each of the plurality of eye/sight headings is associated with a different pre-determined object in an environment. This technology may be used to determine which of the different objects attracts more of the person’s attention. For example, if there are three objects placed in an environment and a person enters the environment navigating his way through it, he may look at one or more of the objects and his eye/sight heading may persist on one or more objects longer than others. This may be used in making or refining the person’s personal attention profile and/or it may be used in connection with other such people’s data on the same or similar objects to determine an impression of how the population or crowd reacts to the objects. Testing advertisements in this way may provide good feedback of its effectiveness.

[0260] In embodiments, the process may involve capturing eye/sight headings once there is substantial alignment between the eye/sight heading and an object of interest. For example, the person with the HWC may be navigating through an environment and once the HWC detects substantial alignment or the projected occurrence of an upcoming substantial alignment between the eye/sight heading and the object of interest, the occurrence and/or persistence may be recorded for use.

[0261] In embodiments, the process may involve collecting eye/sight heading information from a head-worn computer and collecting a captured image from the head-worn computer that was taken at substantially the same time as the eye/sight heading information was captured. These two pieces of information may be used in conjunction to gain an understanding of what the wearer was looking at and possibly interested in. The process may further involve associating the eye/sight heading information with an object, person, or other thing found in the captured image. This may involve processing the captured image looking for objects or patterns. In embodiments, gaze time or persistence may be measured and used in conjunction with the image processing. The process may still involve object and/or pattern recognition, but it may also involve attempting to identify

what the person gazed at for the period of time by more particularly identifying a portion of the image in conjunction with image processing.

[0262] In embodiments, the process may involve setting a pre-determined eye/sight heading from a pre-determined geospatial location and using them as triggers. In the event that a head worn computer enters the geospatial location and an eye/sight heading associated with the head worn computer aligns with the pre-determined eye/sight heading, the system may collect the fact that there was an apparent alignment and/or the system may record information identifying how long the eye/sight heading remains substantially aligned with the pre-determined eye/sight heading to form a persistence statistic. This may eliminate or reduce the need for image processing as the triggers can be used without having to image the area. In other embodiments, image capture and processing is performed in conjunction with the triggers. In embodiments, the triggers may be a series of geospatial locations with corresponding eye/sight headings such that many spots can be used as triggers that indicate when a person entered an area in proximity to an object of interest and/or when that person actually appeared to look at the object.

[0263] In embodiments, eye imaging may be used to capture images of both eyes of the wearer in order to determine the amount of convergence of the eyes (e.g. through technologies described herein elsewhere) to get an understanding of what focal plane is being concentrated on by the wearer. For example, if the convergence measurement suggests that the focal plane is within 15 feet of the wearer, than, even though the eye/sight headings may align with an object that is more than 15 feet away it may be determined that the wearer was not looking at the object. If the object were within the 15 foot suggested focal plane, the determination may be that the wearer was looking at the object.

[0264] Another aspect of the present disclosure relates to collecting other peoples' eye/sight heading and predicting what they appear to be looking at. In embodiments, the process involves capturing image(s) of others through the use of a head-worn computer, understanding the geospatial location of the head-worn computer, processing the captured image(s) of the others to determine a sight heading for each of the others, estimating a geospatial position for each of the others, and then predicting, based on the other persons geospatial location and eye/sight direction, what the other person may be looking at. In embodiments, the image capture process may involve taking a series of images or video such that a persistence factor can be determined. As with other techniques described herein elsewhere, a prediction of the other person's eye/sight heading may be taken after it is recognized that the other person persisted in looking in a direction for a period of time (e.g. 1 or 2 seconds). In embodiments, the person collecting other people's interests (sometimes referred to as a "collector" herein) may locate himself at a particular geospatial location and the capture process may involve capturing images when another person is perceived as looking in a particular direction, as determined by their eye/sight heading, and they persist to look in the direction for a period of time. In embodiments, the series of images or video may be used to observe how the other person's eye/sight heading changes with their movement. For example, if their eye/sight heading continually changes, as if it is connected to something in the environment, while they move, the continual change may be under-

stood as a persistence of gazing at an object in the environment. In embodiments, such a continual eye/sight change may be noted with respect to a person that is not moving, or moving slowly, and understood as a persistence of gaze with respect to a moving object in the environment. In embodiments, eye/sight headings may have a component of vertical aspect as well as horizontal to determine at what altitude the other person appears to be observing.

[0265] FIG. 52 illustrates a person acting as a collector 5202 of others' eye/sight headings and predicting the others' geospatial locations for a prediction of object sight lines. The other people, in this embodiment, are generally referred to as observers. The collector 5202 is wearing a HWC 102 with an internal camera that has a field of view 5214. The collector's HWC 102 also has a GPS sensor so his geospatial location 5218 is known to the HWC 102 and related systems. The collector 5202 captures images of the observers A-D, 5204, 5208, 5210, and 5212. The images can then be processed to determine the apparent eye/sight heading of each of the observers. The eye/sight headings may be associated with a heading that appears to be in-line with an object in the environment (e.g. object A 5220 or object B 5222). Once an association is noted between the eye/sight heading and the object, prediction analytics can be used to establish how long the person appeared to look at the object, if it was truly the object that the person was looking at, if the person was interested in the object, etc.

[0266] Observer A 5204 is in close proximity to the collector 5202. In this embodiment, the predicted GPS location of observer A 5204 appears to be within the predicted GPS location of the collector 5202, or at least near or within the measurement error of the GPS location. In this situation, the collector 5202 may establish observer A's 5204 eye/sight headings and then project an object line from the collector's GPS location, which can be used as an estimate of observer A's 5204 location, to understand if the object line intersects with an object of interest in the environment. Here, as indicated in the illustration, observer A 5204 has an eye/sight heading that appears in line with object B 5222. This may be an indication that observer A 5204 was looking at object B 5222 in the environment.

[0267] Observers B, C, and D, 5208, 5210, and 5212 are not as close to the collector 5202 as observer A 5204. This may cause a prediction of geospatial locations to be made. In embodiments, the collector captures an image of observer B 5208 and processes the image, or the image is processed remotely, to determine the observer's eye/sight heading and a prediction of the observer's geospatial location is also made. The geospatial location prediction may be made through the image processing (e.g. comparing the size of a known object with the size of the observer or portions of the observer, reviewing camera focal distance, etc.) or the location prediction may be based on other sensory input (e.g. a range finder, stereo camera parallax, structured light 3D solutions, etc.). With a prediction of geospatial location and eye/sight headings, an object sight line can be determined and the observer's interest in an intersecting object can be predicted.

[0268] In embodiments, eye and sight headings may be determined through image processing. For example, similar in nature to technologies described herein elsewhere with respect to determining a wearer's eye position, if the observer's eyes are visible in images captured by the camera in the collector's HWC, the observer's eye position may be pre-

dicted based on pupil's position, sclera viewed, symmetry of imagery of the two eyes, etc. If the observer's eyes are not visible in images captured by the camera in the collector's HWC, an approximation of the observer's sight heading may be still be determined by analyzing images captured of the observer by determining the direction of the shoulders and head, the angle of the head to the body, glasses to the body, other head or head-worn items to body parts, etc. For example, from the captured image, one may understand that the shoulders of the observer are at an angle as compared to the collector's camera. Where, the collector's camera angle may be known through an e-compass, or other position sensor, in the HWC 102 of the collector. A determination of the absolute value of the observer's shoulder position may be estimated from image analysis of the collector's body based on a comparison to the collector's e-compass heading. The observer's head position may then be determined by comparing various parts of the observer's head with the position of the observer's shoulders, to establish the observer's sight heading. The sight heading may be determined as a compass angle based on the references in the calculation. If eye position is of interest in addition to the sight heading, the eye position may be referenced by the sight heading to determine the eye heading.

[0269] In a further embodiment, sight headings for a group of observers can be collected by the collector moving through the group. The collected sight heading data can be presented in aggregate or by location within an area. Additional analysis of the images of the observers can be used to simultaneously determine general characteristics of the observers such as: height, volume (or weight), gender, age or race. This general characteristic data can be combined with the determined sight heading data to determine additional information about the type of people that are looking at specific objects in the environment.

[0270] Another aspect of the present disclosure relates to an optical configuration that provides digitally displayed content to an eye of a person wearing a head-worn display (e.g. as used in a HWC 102) and allows the person to see through the display such that the digital content is perceived by the person as augmenting the see through view of the surrounding environment. The optical configuration may have a variable transmission optical element that is in-line with the person's see-through view such that the transmission of the see-through view can be increased and decreased. This may be helpful in situations where a person wants or would be better served with a high transmission see-through view and when, in the same HWC 102, the person wants or would be better served with less see-through transmission. The lower see-through transmission may be used in bright conditions and/or in conditions where higher contrast for the digitally presented content is desirable. The optical system may also have a camera that images the surrounding environment by receiving reflected light from the surrounding environment off of an optical element that is in-line with the person's see-through view of the surrounding. In embodiments, the camera may further be aligned in a dark light trap such that light reflected and/or transmitted in the direction of the camera that is not captured by the camera is trapped to reduce stray light.

[0271] In embodiments, a HWC 102 is provided that includes a camera that is coaxially aligned with the direction that the user is looking. FIG. 53 shows an illustration of an optical system 5315 that includes an absorptive polarizer

5337 and a camera 5339. The image source 5310 can include light sources, displays and reflective surfaces as well as one or more lenses 5320. Image light 5350 is provided by the image source 5310 wherein, a portion of the image light 5350 is reflected toward the user's eye 5330 by a partially reflective combiner 5335. At the same time, a portion of the image light 5350 may be transmitted by the combiner 5335 such that it is incident onto the absorptive polarizer 5337. In this embodiment, the image light 5350 is polarized light with the polarization state of the image light 5350 oriented relative to the transmission axis of the absorptive polarizer 5337 such that the incident image light 5350 is absorbed by the absorptive polarizer 5337. In this way, faceglow produced by escaping image light 5350 is reduced. In embodiments, the absorptive polarizer 5337 includes an antireflection coating to reduce reflections from the surface of the absorptive polarizer 5337.

[0272] FIG. 53 further shows a camera 5339 for capturing images of the environment in the direction that the user is looking. The camera 5339 is positioned behind the absorptive polarizer 5337 and below the combiner 5335 so that a portion of light from the environment 5370 is reflected by the combiner 5335 toward the camera 5339. Light from the environment 5370 can be unpolarized so that a portion of the light from the environment 5370 that is reflected by the combiner 5335 passes through the absorptive polarizer 5337 and it is this light that is captured by the camera 5339. As a result, the light captured by the camera will have a polarization state that is opposite that of the image light 5350. In addition, the camera 5339 is aligned relative to the combiner 5335 such that the field of view associated with the camera 5339 is coaxial to the display field of view provided by image light 5350. At the same time, a portion of scene light 5360 from the environment is transmitted by the combiner 5335 to provide a see-through view of the environment to the user's eye 5330. Where the display field of view associated with the image light 5350 is typically coincident to the see-through field of view associated with the scene light 5360 and thereby the see through field of view and the field of view of the camera 5339 are at least partially coaxial. By attaching the camera 5339 to the lower portion of the optical system 5315, the field of view of the camera 5339 as shown by the light from the environment 5370 moves as the user moves their head so that images captured by the camera 5339 correspond to the area of the environment that the user is looking at. By coaxially aligning the camera field of view with the displayed image and the user's view of the scene, augmented reality images with improved alignment to objects in the scene can be provided. This is because the captured images from the camera 5339 provide an accurate representation of the user's perspective view of the scene. As an example, when the user sees an object in the scene as being located in the middle of the see-through view of the HWC, the object will be located in the middle of the image captured by the camera and any augmented reality imagery that is to be associated with the object can be located in the middle of the displayed image. As the user moves their head, the relative position of the object as seen in the see-through view of the scene will change and the position of the augmented reality imagery can be changed within the displayed image in a corresponding manner. When a camera 5339 is provided for each of the user's eyes, an accurate representation of the 3D view of the scene can be provided as well. This is an important advantage provided by the

disclosure because images captured by a camera located in the frame of the HWC (e.g. between the eyes or at the corners) capture images that are laterally offset from the user's perspective of the scene and as a result it is difficult to align augmented reality images with objects in the scene as seen from the user's perspective.

[0273] In the optical system 5315 shown in FIG. 53, the absorptive polarizer 5337 simultaneously functions as a light trap for escaping image light 5350, a light blocker of the image light 5350 for the camera 5339 and a window for light from the environment 5370 to the camera 5339. This is possible because the polarization state of the image light 5350 is perpendicular to the transmission axis of the absorptive polarizer 5337 while the light from the environment 5370 is unpolarized so that a portion of the light from the environment 5370 that is the opposite polarization state to the image light is transmitted by the absorptive polarizer 5337. The combiner 5335 can be any partially reflective surface including a simple partial mirror, a notch mirror and a holographic mirror. The reflectivity of the combiner 5335 can be selected to be greater than 50% (e.g. 55% reflectivity and 45% transmission over the visible wavelength spectral band) whereby a majority of the image light 5350 will be reflected toward the user's eye 5330 and a majority of light from the environment 5370 will be reflected toward the camera 5339, this system will provide a brighter displayed image, a brighter captured image with a dimmer see-through view of the environment. Alternatively, the reflectivity of the combiner 5335 can be selected to be less than 50% (e.g. 20% reflectivity and 80% transmission over the visible wavelength spectral band) whereby the majority of the image light 5350 will be transmitted by the combiner 5335 and a majority of light from the environment 5370 will be transmitted to the user's eye 5330, this system will provide a brighter see-through view of the environment, while providing a dimmer displayed image and a dimmer captured image. As such, the system can be designed to favor the anticipated use by the user.

[0274] In embodiments, the combiner 5335 is planar with an optical flatness that is sufficient to enable a sharp displayed image and a sharp captured image, such as a flatness of less than 20 waves of light within the visible wavelengths. However, in embodiments, the combiner 5335 may be curved in which case the displayed image and the captured image will both be distorted and this distortion will have to be digitally corrected by the associated image processing system. In the case of the displayed image, the image is digitally distorted by the image processing system in a direction that is opposite to the distortion that is caused by the curved combiner so the two distortions cancel one another and as a result the user sees an undistorted displayed image. In the case of the captured image, the captured image is digitally distorted after capture to cancel out the distortion caused by the curved combiner so that the image appears to be undistorted after image processing.

[0275] In embodiments, the combiner 5335 is an adjustable partial mirror in which the reflectivity can be changed by the user or automatically to better function within different environmental conditions or different use cases. The adjustable partial mirror can be an electrically controllable mirror such as for example, the e-Transflector that can be obtained from Kent Optronics (<http://www.kentoptronics.com/mirror.html>) where the reflectivity can be adjusted based on an applied voltage. The adjustable partial mirror

can also be a fast switchable mirror (e.g. a switching time of less than 0.03 seconds) wherein the perceived transparency is derived from the duty cycle of the mirror rapidly switching between a reflecting state and a transmitting state. In embodiments, the images captured by the camera 5339 can be synchronized to occur when the fast switchable mirror is in the reflecting state to provide an increased amount of light to the camera 5339 during image capture. As such, an adjustable partial mirror allows for the transmissivity of the partial mirror to be changed corresponding to the environmental conditions, e.g. the transmissivity can be low when the environment is bright and the transmissivity can be high when the environment is dim.

[0276] In a further embodiment, the combiner 5335 includes a hot mirror coating on the side facing the camera 5339 wherein visible wavelength light is substantially transmitted while a spectral wavelength band of infrared light is substantially reflected and the camera 5339 captures images that include at least a portion of the infrared wavelength light. In these embodiments, the image light 5350 includes visible wavelength light and a portion of the visible wavelength light is transmitted by the combiner 5335, where it is then absorbed by the absorptive polarizer 5337. A portion of the scene light 5360 is comprised of visible wavelength light and this is also transmitted by the combiner 5335, to provide the user with a see-through view of the environment. The light from the environment 5370 is comprised of visible wavelength light and infrared wavelength light. A portion of the visible wavelength light along with substantially all of the infrared wavelength light within the spectral wavelength band associated with the hot mirror, is reflected by the combiner 5335 toward the camera 5339 thereby passing through the absorptive polarizer 5337. In embodiments, the camera 5339 is selected to include an image sensor that is sensitive to infrared wavelengths of light and the absorptive polarizer 5337 is selected to substantially transmit infrared wavelengths of light of both polarization states (e.g. ITOS XP44 polarizer which transmits both polarization states of light with wavelengths above 750 nm: see <http://www.itos.de/english/polarisatoren/linear/linear.php>) so that an increased % of infrared light is captured by the camera 5339. In these embodiments, the absorptive polarizer 5337 functions as a light trap for the escaping image light 5350 and thereby blocking the image light 5350 that is in the visible wavelengths from the camera 5339 while simultaneously acting as a window for infrared wavelength light from the environment 5370 for the camera 5339.

[0277] By coaxially aligning the camera field of view with the displayed image and the user's view of the scene, augmented reality images with improved alignment to objects in the scene can be provided. This is because the captured images from the camera provide an accurate representation of the user's perspective view of the scene. In embodiments, the camera that is coaxially aligned with the user's view captures an image of the scene, the processor then identifies an object in the captured image and identifies a field of view position for the object, which can be compared to the displayed field of view correlated position so digital content is then displayed relative to the position of the object.

[0278] Another aspect of the present disclosure relates to an optical assembly that uses a reflective display where the reflective display is illuminated with a front light arranged to direct the illumination at angles around 90 degrees from the

active reflective surface of the reflective display. In embodiments, the optical configuration is light weight, small and produces a high quality image in a head-worn see-through display.

[0279] FIG. 54 provides a cross sectional illustration of the compact optical display assembly for a HWC 102 according to principles of the present disclosure along with illustrative light rays to show how the light passes through the assembly. The display assembly is comprised of upper optics and lower optics. The upper optics include a reflective image source 5410, a quarter wave film 5415, a field lens 5420, a reflective polarizer 5430 and a polarized light source 5450. The upper optics convert illumination light 5437 into image light 5435. The lower optics comprise a beam splitter plate 5470 and a rotationally curved partial mirror 5460. The lower optics deliver the image light to a user who is wearing the HWC 102. The compact optical display assembly provides the user with image light 5435 that conveys a displayed image along with scene light 5465 that provides a see-through view of the environment so that user sees the displayed image overlaid onto the view of the environment.

[0280] In the upper optics, linearly polarized light is provided by the polarized light source 5450. Where the polarized light source 5450 can include one or more lights such as LEDs, QLEDs, laser diodes, fluorescent lights, etc. The polarized light source 5450 can also include a backlight assembly with light scattering surfaces or diffusers to spread the light uniformly across the output area of the polarized light source. Light control films or light control structures can be included as well to control the distribution of the light (also known as the cone angle) that is provided by the polarized light source 5450. The light control films can include, for example, diffusers, elliptical diffusers, prism films and lenticular lens arrays. The light control structures can include prism arrays, lenticular lenses, cylindrical lenses, Fresnel lenses, refractive lenses, diffractive lenses or other structures that control the angular distribution of the illumination light 5437. The output surface of the polarized light source 5450 is a polarizer film to ensure that the illumination light 5437 provided to the upper optics is linearly polarized.

[0281] The illumination light 5437 provided by the polarized light source 5450 is reflected by a reflective polarizer 5430. Where the polarizer on the output surface of the polarized light source 5450 and the reflective polarizer 5430 are oriented so that their respective transmission axes are perpendicular to one another. As a result, the majority of the illumination light 5437 provided by the polarized light source 5450 is reflected by the reflective polarizer 5430. In addition, the reflective polarizer 5430 is angled so that the illumination light 5437 is reflected toward the reflective image source 5410 thereby illuminating the reflective image source 5410 as shown in FIG. 54.

[0282] The illumination light 5437 passes through a field lens 5420 and is then incident onto the reflective image source 5410. The illumination light 5437 is then reflected by the reflective image source (otherwise referred to as a reflective display herein elsewhere) 5410. Wherein the reflective image source 5410 can comprise a liquid crystal on silicon (LCOS) display, a ferroelectric liquid crystal on silicon (FLCSO) display, a reflective liquid crystal display, a cholesteric liquid crystal display, a bistable nematic liquid crystal display, or other such reflective display. The display can be a monochrome reflective display that is used with

sequential red/green/blue illumination light 5437 or a full color display that is used with white illumination light 5437. The reflective image source 5410 locally changes the polarization state of the illumination light 5437 in correspondence to the pixel by pixel image content that is displayed by the reflective image source 5410 thereby forming image light 5435. Wherein if the reflective image source 5410 is a normally white display, the areas of the image light 5435 that correspond to bright areas of the image content end up with a polarization state that is opposite to the polarization state of the illumination light and dark areas of the image light 5435 end up with a polarization state that is the same as the illumination light 5437 (it should be noted that the disclosure can be used with normally black displays which provide an opposite effect on polarization in the image light). As such, the image light 5435 as initially reflected by the reflective image source 5410 has a mixed polarization state pixel by pixel. The image light 5435 then passes through the field lens 5420 which modifies the distribution of the image light 5435 while preserving the wavefront to match the requirements (such as for example, magnification and focus) of the lower optics. As the image light 5435 passes through the reflective polarizer 5430, the bright areas of the image light 5435 that have a polarization state that is opposite to the illumination light 5437 are transmitted through the reflective polarizer 5430 and the dark areas of the image light 5435 that have the same polarization state as the illumination light 5437 are reflected back toward the polarized light source 5450, as a result, the image light 5435 after passing through the reflective polarizer 5430 is linearly polarized with a single polarization state in all the pixels of the image but now with different intensities pixel by pixel. Thus the reflective polarizer 5430 acts first as a reflector for the illumination light 5437 and then second as an analyzer polarizer for the image light 5435.

[0283] As such, the optical axis of the illumination light 5437 is coincident with the optical axis of the image light 5435 between the reflective polarizer 5430 and the reflective image source 5410. The illumination light 5437 and the image light

[0284] 5435 both pass through the field lens 5420, but in opposite directions. Wherein the field lens acts to expand the illumination light 5437 so it illuminates the entire active area of the reflective image source 5410 and also to expand the image light 5435 so it fills the eyepiece 5482 after passing through the rest of the compact optical display system. By overlapping the portion of the compact optical display assembly associated with the illumination light 5437 with the portion of the compact optical display assembly associated with the image light 5435, the overall size of the compact optical display assembly is reduced. Given that the focal length associated with the field lens 5420 requires some space in the compact optical display assembly, the reflective polarizer 5430 and the polarized light source 5450 are located in space that would otherwise be unused so the overall size of the display assembly is more compact.

[0285] The reflective polarizer 5430 can be a relatively thin film (e.g. 80 microns) or thin plate (e.g. 0.2 mm) as shown in FIG. 54. The reflective polarizer 5430 can be a wiregrid polarizer such as is available from Asahi Kasei under the name WGF, or a multilayer dielectric film polarizer such as is available from 3M under the name DBEF. As previously described, the reflective polarizer 5430 has two functions. First, the reflective polarizer 5430 reflects the

illumination light 5437 provided by the polarized light source 5450 and redirects the illumination light 5437 toward the reflective image source 5410. Second, the reflective polarizer 5430 acts as an analyzer polarizer to the image light 5435 thereby converting the mixed polarization state of the image light 5435 above the reflective polarizer 5430 to linearly polarized light with a single polarization state below the reflective polarizer 5430. While the illumination light 5437 incident on the reflective polarizer 5430 is incident on a relatively small portion of the reflective polarizer 5430, the image light 5435 is incident on the majority of the area of the reflective polarizer 5430. Consequently, the reflective polarizer 5430 extends at least across the entire area of the field lens 5420 and may extend across the entire area between the field lens 5420 and the beam splitter 5470 as shown in FIG. 54. In addition, the reflective polarizer 5430 is angled at least in the portion where the illumination light 5437 is incident to redirect the illumination light 5437 toward the reflective image source 5410. However, since reflective polarizers (such as a wiregrid polarizer) can be relatively insensitive to the incident angle, in a preferred embodiment, the reflective polarizer 5430 is a flat surface angled to redirect the illumination light 5437 toward the reflective image source 5410 wherein the flat surface extends substantially across the entire area between the field lens 5420 and the beam splitter 5470 in one continuously flat surface to make manufacturing easier. The thin film or thin plate of the reflective polarizer 5470 can be retained at the edges to position it at the desired angle and to make the surface flat.

[0286] The systems and methods described herein with respect to FIGS. 54 through 57 have a number of advantages. By avoiding grazing angles of the illumination light 5437 and the image light 5435 at all the surfaces in the compact optical display assembly, scattering of light in the assembly is reduced and as a result the contrast of the image presented to the user's eye 5480 is higher with blacker blacks. In addition, the reflective image source 5410 can include a compensating retarder film 5415 as is known to those skilled in the art, to enable the reflective image source 5410 to provide a higher contrast image with more uniform contrast over the area of the displayed image. Further, by providing an optical display assembly that is largely comprised of air, the weight of the compact optical display assembly is substantially reduced. By using coincident optical axes for the illumination light 5437 and the image light 5435 and overlapping the illumination light 5437 and image light 5435 for a substantial portion of the optical display assembly, the overall size of the compact optical display assembly is reduced. Where the coincident optical axes are provided by passing the illumination light 5437 and the image light 5435 in opposite directions through the field lens 5420. To maintain a uniform polarization state for the illumination light 5437, the field lens 5420 is made from a low birefringence material such as glass or a plastic such as OKP4 as available from Osaka Gas Chemicals. By positioning the polarized light source 5450 and the associated illumination light 5437 below the field lens 5420, and by folding the optical path of both the illumination light 5437 at the reflective polarizer 5430 and the image light 5435 at the beam splitter 5470, the overall height of the compact optical display assembly is greatly reduced. For example the overall height of the compact optical display assembly can be less than 24 mm as measured from the reflective image source 5410 to the bottom edge of the rotationally curved

partial mirror 5460 for a display that provides a 30 degree diagonal field of view with a 6x10 mm eyebox.

[0287] In a preferred case, the light control structure in the polarized light source 5450 includes a positive lens, such as for example a positive Fresnel lens, a positive diffractive lens or a positive refractive lens. Wherein a positive Fresnel lens or a positive diffractive lens is preferred because they can be very thin. The illumination light 5437 is thereby focused to form a smaller area or pupil at the reflective polarizer 5430 that has a direct relationship to the area of an eyebox 5482 at the other end of the optics wherein image light 5435 is provided to the user's eye 5480 as shown in FIG. 54. Where the positive lens concentrates the illumination light 5437 from the polarized light source 5450 both in terms of intensity and angular distribution to match the etendue of the optical system and thereby fills the eyebox with image light 5435. By using the positive lens to converge the light from the polarized light source 5450 as provided to the reflective polarizer 5430 and then using the field lens 5420 to expand the illumination light 5437 to illuminate the active area of the reflective image source 5410, efficiency is improved since illumination light 5437 is substantially delivered only where needed to form image light 5435. Further, illumination light 5437 outside the pupil can be controlled by the positive lens and clipped by masked edges of the positive lens. By focusing the illumination light 5437 and clipping light outside the pupil, illumination light 5437 is prevented from impinging adjacent surfaces at grazing angles in the compact optical display assembly to reduce scattering of light and thereby increase contrast in the image provided to the user's eye 5480 by providing blacker blacks.

[0288] It should be noted that while FIGS. 54, 55 and 56 show optical layouts wherein the illumination light 5437 is provided from behind the rotationally curved partial mirror 5460, other optical layouts are possible within the disclosure. The location of the polarized light source 5450 can be changed for example to be at the side of the rotationally curved partial mirror 5460 wherein the reflective polarizer 5430 is oriented to receive the illumination light 5437 from the side. And reflect it toward the reflective image source 5410 (not shown).

[0289] In a further embodiment, the portion of the image light 5435 that is reflected back toward the polarized light source 5450 is recycled in the polarized light source 5450 to increase the efficiency of the polarized light source 5450. In this case, a diffuser and a reflective surface is provided behind the polarized light source 5450 so the polarization of the light is scrambled and reflected back toward the reflective polarizer 5430.

[0290] In yet another embodiment, another reflective polarizer is provided in the polarized light source 5450 and behind the linear polarizer previously disclosed. Wherein the respective transmission axes of the reflective polarizer and the linear polarizer are parallel to one another. The other reflective polarizer then reflects the light back into the backlight that has the polarization state that would not be transmitted by the linear polarizer. The light that is reflected back into the backlight passes through diffusers associated with the polarized light source 5450 where the polarization state is scrambled and reemitted thereby recycling the light and increasing efficiency.

[0291] In another embodiment, the system according to the principles of the present disclosure includes an eye

imaging system. FIG. 55 is an illustration of a compact optical display assembly, which includes an eye imaging camera 5592 that captures an image of the user's eye 5480 that is coaxial with the displayed image provided to the user so that a full image of the user's iris can be reliably captured. The eye imaging camera 5592 is reflected into the lower optics by a reflective polarizer 5530 that includes a notch mirror coating, facing the eye imaging camera 5592, that reflects the wavelengths of light that are captured by the eye imaging camera 5592 (e.g. near infrared wavelengths) while transmitting wavelengths associated with the image light 5435 (e.g. visible wavelengths). Eye light rays 5595 shown in FIG. 55 illustrate how the field of view associated with the eye imaging camera 5592 is a relatively narrow field of view because it is multiply reflected through the lower optics to capture an image of the user's eye 5480. However, to enable the eye imaging camera 5592 to focus onto the user's eye 5480, the eye imaging camera 5592 needs to have a very near focus distance (e.g. 35 mm). In addition, the field of view and focus distance of the eye imaging camera must take into account the reducing effect of the optical power provided by the rotationally curved partial mirror 5460. To increase the efficiency of capturing the light reflected from the user's eye 5480 and thereby enable a brighter image of the eye, the rotationally curved partial mirror 5460 can be coated with a partial mirror coating that acts as a full mirror in the wavelengths being captured by the eye imaging camera 5592, for example the coating can reflect 50% of visible light associated with the image light and 90% of near infrared light associated with the eye light 5595. Where the reflections and associated changes in polarization state are similar to those associated with the image light 5435 but in the opposite order since the eye light rays 5595 are coming from the user's eye 5480. LEDs or other miniature lights are provided adjacent to the user's eye 5480 to illuminate the user's eye 5480 wherein the wavelengths associated with the LED's or other miniature lights are different than the wavelengths associated with the image light 5435 such as for example near infrared wavelengths (e.g. 850 nm, 940 nm or 1050 nm). Alternatively, the image light 5435 is used to illuminate the user's eye 5480 and a reflective polarizer 5530 with a low extinction ratio in reflection (e.g. reflective extinction ratio <15) is used so that some of the eye light rays are reflected toward the eye imaging camera 5592.

[0292] In an alternative embodiment, the reflective and partially reflective surfaces can extend laterally to the sides of the areas used for displaying an image to the user. In this case, the eye imaging camera can be located adjacent to the field lens and pointed in a direction to image the user's eye after reflecting from the beam splitter and the rotationally curved partial mirror as shown in FIG. 56. Where FIG. 56 is an illustration that shows an eye imaging camera 5692 positioned to the side of the field lens 5420 and reflective polarizer 5430. The eye imaging camera 5692 is pointed such that the field of view captured by the eye imaging camera 5692 includes the user's eye 5480 as illustrated by the eye light rays 5695. The quarter wave film 5490 is also extended laterally to change the polarization state of the eye light 5695 in the same way that the polarization state of the image light is changed so that the eye light passes through the beam splitter 5470 and quarter wave 5490, is partially reflected by the rotationally curved partial mirror 5460 and is then reflected by the beam splitter 5470 and is then captured by the eye imaging camera 5692. By positioning

the eye imaging camera 5692 to the side of the field lens 5420 and reflective polarizer 5430, the complexity of the optics associated with displaying an image to the user is reduced. In addition, the space available for the eye imaging camera 5692 is increased since interferences with the display optics are reduced. By positioning the eye imaging camera 5692 adjacent to the display optics, the eye image is captured nearly coaxially with the displayed image.

[0293] In a yet another embodiment, the systems according to the principles of the present disclosure include a field lens with an internal reflective polarizer and one or more surfaces with optical power. FIG. 57 is an illustration of the upper optics including a field lens 5721 comprised of upper prism 5722 and lower prism 5723. The upper prism 5722 and the lower prism 5723 can be molded to shape or grind and polished. A reflective polarizer 5724 is interposed on the flat surface between the upper prism 5722 and the lower prism 5723. The reflective polarizer 5724 can be a wiregrid polarizer film or a multilayer dielectric polarizer as previously mentioned. The reflective polarizer 5724 can be bonded into place with a transparent UV curable adhesive that has the same refractive index as the upper prism 5722 or the lower prism 5723. Typically the upper prism 5722 and the lower prism 5723 would have the same refractive index. Wherein upper prism 5722 includes an angled surface for illumination light 5437 to be provided to illuminate the reflective image source 5410. The illumination light is provided by a light source that includes lights such as LEDs, a backlight 5751, a diffuser 5752 and a polarizer 5753 as has been previously described. The lower prism 5723 includes a curved surface on the exit surface for controlling the wavefront of the image light 5435 as supplied to the lower optics. The upper prism may also include a curved surface on the upper surface next to the reflective image source 5410 as shown in FIG. 57 for manipulating the chief ray angles of the light at the surface of the reflective image source 5410. Illumination light 5437 is polarized by the polarizer 5753 prior to entering the upper prism 5722. The transmission axes of the polarizer 5753 and the reflective polarizer 5724 are perpendicular to one another so that the illumination light 5437 is reflected by the reflective polarizer 5724 so that the illumination light is redirected toward the reflective image source 5410. The polarization state of the illumination light 5437 is then changed by the reflective image source 5410 in correspondence with the image content to be displayed as previously described and the resulting image light 5435 then passes through the reflective polarizer 5724 to form the bright and dark areas associated with the image that is displayed to the user's eye 5480.

[0294] In another embodiment, the field lens 5721 of FIG. 57 comprises a polarizing beam splitter cube including two prisms, upper prism 5722 and lower prism 5723. In this case, the reflective polarizer 5724 is replaced by a coating that is polarization sensitive so that light of one polarization state (typically S polarized light for example) is reflected and light of the other polarization state is transmitted. The illumination light 5437 is then provided with the polarization state that is reflected by the coating and the image light is provided with the polarization state that is transmitted by the coating. As shown in FIG. 57, the beam splitter cube includes one or more curved surfaces in the upper prism 5722 or the lower prism 5723. The beam splitter cube can also include one or more angled surfaces where the illumination light is supplied. The angled surface can include light

control structures such as a microlens array to improve the uniformity of the illumination light **5437**, or a lenticular array to collimate the illumination light **5437**.

[0295] In yet another embodiment, the curved surface(s) or the angled surface(s) illustrated in FIG. **57** can be molded onto a rectangularly shaped beam splitter cube by casting a UV curable material (e.g. UV curable acrylic) onto a flat surface of a beam splitter cube, placing a transparent mold with a cavity that has the desired curve onto the flat surface to force the UV curable material into the desired curve and applying UV light to cure the UV curable material. The beam splitter cube can be made of a material that has the same or different refractive index than the UV curable material.

[0296] In a further embodiment, polarization sensitive reflective coatings such as dielectric partial mirror coatings, can be used in place of reflective polarizers or beam splitters as shown in FIG. **54**. In this case, the reflective films and plates that comprise the reflective polarizers **5430** and beam splitters **5470** include polarization sensitive coatings that substantially reflect light with one polarization state (e.g. S polarization) while substantially transmitting light with the other polarization state (e.g. P polarization). Since the illumination light source includes a polarizer **5753**, the illumination light **5437** is one polarization state and it is not important that the reflective polarizer **5724** be sensitive to the polarization state in reflection, the polarization state just needs to be maintained and presented uniformly over the surface of the reflective image source **5410**. However, it is important that the reflective polarizer **5724** be highly sensitive to polarization state in transmission (e.g. extinction ratio >200) to be an effective polarizer analyzer and to provide a high contrast image (e.g. contrast ratio >200) to the user's eye **5480**.

[0297] In a further embodiment, the field lens **5721** shown in FIG. **57** can comprise a reflective polarizer **5724** with a curved surface (not shown) instead of a flat surface and wherein the reflective polarizer **5724** is not a film and instead is a polarization sensitive coating, a printed wiregrid polarizer or a molded wiregrid pattern that is then metallized. In this case, the upper prism **5722** and the lower prism **5723** are made as a matched pair with mating curved surfaces that together form the surface of the reflective polarizer. Wherein the polarization sensitive coating, the printed wiregrid or the molded wiregrid pattern are applied to the mating curved surface associated either the upper prism **5722** or the lower prism **5723** and a transparent adhesive is applied to the other mating surface to bond the upper prism **5722** and lower prism **5723** together to form the field lens **5721** with an internal curved reflective polarizer **5721**.

[0298] Although embodiments of HWC have been described in language specific to features, systems, computer processes and/or methods, the appended claims are not necessarily limited to the specific features, systems, computer processes and/or methods described. Rather, the specific features, systems, computer processes and/or methods are disclosed as non-limited example implementations of HWC.

[0299] All documents referenced herein are hereby incorporated by reference.

We claim:

1. An optical system for a head-worn computer, comprising:

an upper optical module adapted to convert illumination into image light by illuminating a reflective display through a field lens, wherein the image light is transmitted back through the field lens, then through a partially reflective partially transmissive surface and into a lower optic module adapted to present the image light to an eye of a user wearing the head-worn computer; and

the upper optical module being positioned within a housing for the head-worn computer and having a height of less than 24 mm, as measured from the reflective display to the bottom edge of the rotationally curved partial mirror.

2. An optical system for a head-worn computer, comprising:

a polarized light source including a lens with positive optical power positioned in the head-worn computer within an upper optical assembly provides illumination light, wherein the illumination light is projected away from a reflective image source and towards a partially reflective partially transmissive surface and wherein the lens converges the illumination light into a small area in a central region of the partially reflective partially transmissive surface to prevent the illumination light from impinging on sidewalls of the upper optical assembly and thereby reduce scattering;

the partially reflective partially transmissive surface positioned to reflect the polarized light through a field lens and towards the reflective display, wherein the field lens expands the illumination light to illuminate an active area of the reflective image source; and

an eye image display optical assembly positioned to receive image light reflected from the reflective display, through the field lens and through the partially reflective partially transmissive surface and present the image light to an eye of a user wearing the head-worn computer.

* * * * *