

COMMONWEALTH of AUSTRALIA
Patents Act 1952

APPLICATION FOR A STANDARD PATENT

62 1377

I/We

Robert L. Propst

of

18845 N. E. 49th Place, Redmond, Washington, 98052, United States of America

hereby apply for the grant of a Standard Patent for an invention entitled:

Building enclosure system and method

which is described in the accompanying complete specification.

Details of basic application(s):-

<u>Number</u>	<u>Convention Country</u>	<u>Date</u>
208896	United States of America	17 June 1988

The address for service is care of DAVIES & COLLISON, Patent Attorneys, of 1 Little Collins Street, Melbourne, in the State of Victoria, Commonwealth of Australia.

DATED this FIFTEENTH day of JUNE 1989

To: THE COMMISSIONER OF PATENTS



.....
a member of the firm of
DAVIES & COLLISON for
and on behalf of the
applicant(s)

Davies & Collison, Melbourne

M 009881 150689

COMMONWEALTH OF AUSTRALIA
Patents Act 1952
DECLARATION IN SUPPORT OF CONVENTION OR
NCN-CONVENTION APPLICATION FOR A PATENT

In support of the Application made for a patent for an invention entitled:

BUILDING ENCLOSURE SYSTEM AND METHOD

I, Robert L. Propst, 18845 North East 49th Place, Redmond, Washington 98052, do solemnly and sincerely declare that:

1. I am the actual inventor of the invention.

1a. I am the applicant for the Patent.

2. The basic application as defined by Section 141 of the Act was made in the United States on the June 17, 1988, by Robert L. Propst.

3. The basic application referred to in paragraph 2 of this Declaration was the first application made in a Convention Country in respect of the invention the subject of the application.

Declared at ¹⁴²⁰ 13th this 13th day of June
Redmond, WA

Robert L. Propst
Robert L. Propst

(12) PATENT ABRIDGMENT (11) Document No. AU-B-36450/89
(19) AUSTRALIAN PATENT OFFICE (10) Acceptance No. 621377

- (54) Title
WALL PANELS
- International Patent Classification(s)
(51)⁴ E04B 002/74 E04B 001/40 E04B 002/82
- (21) Application No. : 36450/89 (22) Application Date : 15.06.89
- (30) Priority Data
- (31) Number (32) Date (33) Country
208896 17.06.88 US UNITED STATES OF AMERICA
- (43) Publication Date : 21.12.89
- (44) Publication Date of Accepted Application : 12.03.92
- (71) Applicant(s)
ROBERT L. PROPST
- (72) Inventor(s)
ROBERT L. PROPST
- (74) Attorney or Agent
DAVIES COLLISON CAVE , 1 Little Collins Street, MELBOURNE VIC 3000
- (56) Prior Art Documents
US 4045927
- (57) Claim

1. A building structure comprising:
 - a floor structure;
 - a ceiling structure;
 - a support structure between the floor structure and ceiling structure for supporting the latter;
 - a wall structure between the ceiling structure and the floor structure which does not support the ceiling structure, said wall structure including a row of side-by-side wall panels, said panels being spaced by a gap beneath said ceiling structure and interfitting with the floor structure such as to be removable when tilted from a vertical position;
 - extendible means operable between adjacent said wall panels for interfitting with said ceiling structure when engaged for holding said panels in vertical position when the wall panels interfit with said floor structure;
 - and
 - panel gripping means operable between adjacent said wall panels when engaged for holding the wall panels against movement relative to one another, said wall panels having accessways therebetween to said extendible means and panel gripping means for operation thereof;
 - said extendible means and panel gripping means

(11) AU-B-36450/89
(10) 621377

-2-

being adapted to be moved through said accessways and to be engaged and disengaged by a tool inserted through said accessways when a cover means is removed therefrom, whereby each of said wall panels may be individually installed and removed without moving adjacent wall panels.

6. A wall structure comprising:

a pair of coplanar panels having opposed longitudinal meeting edges presenting opposed longitudinal recesses, each having opposed longitudinal recess faces, said panels collectively providing a longitudinal accessway giving external access to said longitudinal recesses along substantially the length thereof when said meeting edges are in engagement; and

clamping means gripping said recess faces by a spreading action, said clamping means having a clamping mode and a released mode, said clamping means being adapted when in its released mode to pass in its entirety through said accessway to a position between said recesses and to be then turned into a position occupying said opposed recesses and activated to its clamping mode gripping said matching recess faces by operation of a tool passing through said accessway.

13. A method for connecting two side-by-side panels that are formed with opposed edge grooves each having a center groove face between front and back groove faces and that provide a front entryway to said grooves:

providing a connecting unit having two spreader elements which are narrower than the entry way and longer than the distance between said center groove faces of the opposed edge grooves, and having a central screw operating when turned to spread said spreader elements apart when they are restrained from turning;

passing said connector unit through said entryway to said grooves with the length of the spreader elements lengthwise of the entryway and said screw exposed to the entryway;

turning the connecting unit until the ends of the

(11) AU-B-36450/89
(10) 621377

- 3 -

spreader elements engage said center groove faces, thereby restraining the spreader elements from further turning;

turning said screw with a tool passing through the entryway such as to spread the spreader elements apart until they firmly engage said front and back groove faces; and

removing the tool.

621377

COMMONWEALTH OF AUSTRALIA
PATENTS ACT 1952
COMPLETE SPECIFICATION

NAME & ADDRESS
OF APPLICANT:

Robert L. Propst
18845 N. E. 49th Place
Redmond Washington 98052
United States of America

NAME(S) OF INVENTOR(S):

Robert L. PROPST

ADDRESS FOR SERVICE:

DAVIES & COLLISON
Patent Attorneys
1 Little Collins Street, Melbourne, 3000.

COMPLETE SPECIFICATION FOR THE INVENTION ENTITLED:

Building enclosure system and method

The following statement is a full description of this invention, including the best method of performing it known to me/us:-

The present invention relates to building systems of the type having interior and exterior non-load-bearing walls formed by modular, prefabricated wall panel, which can be moved and substituted on site to vary floor plans and wall details.

In the past, various systems have been used to connect prefabricated wall panels in place, but they have normally failed to preserve a modular relationship making it possible to assemble the panels exactly in accordance with a preset layout program and they have failed to enable the panels to be easily changed without disturbing adjoining panels. These failures have resulted in large part because the location of each successive panel during the erection process was made dependent upon the position of the previously erected panels, and the hardware interconnecting the panels tended to draw the panels toward one another during installation. Also, normally the hardware was either permanently attached or screw-attached to the wall panels, and if designed to be hidden from view, commonly required special recesses or pockets to be formed in the panels for housing the hardware. Release of the hardware of an intermediate wall panel was either impossible, difficult, or required access to both sides of the panel, or required releasing space and access at the top of the panels.

According to a first aspect of the present invention there is provided a building structure comprising:

- a floor structure;
- a ceiling structure;
- a support structure between the floor structure and ceiling structure for supporting the latter;
- a wall structure between the ceiling structure and the floor structure which does not support the ceiling structure, said wall structure including a row of side-by-side wall panels, said panels being spaced by a gap beneath said ceiling structure and interfitting with the floor

5
10
15
20
25
30
35



structure such as to be removable when tilted from a vertical position;

extendible means operable between adjacent said wall panels for interfitting with said ceiling structure
5 when engaged for holding said panels in vertical position when the wall panels interfit with said floor structure; and

panel gripping means operable between adjacent said wall panels when engaged for holding the wall panels
10 against movement relative to one another, said wall panels having accessways therebetween to said extendable means and panel gripping means for operation thereof;

said extendable means and panel gripping means being adapted to be moved through said accessways and to be
15 engaged and disengaged by a tool inserted through said accessways when a cover means is removed therefrom, whereby each of said wall panels may be individually installed and removed without moving adjacent wall panels.

According to a second aspect of the present
20 invention there is provided a wall structure comprising:

a pair of coplanar panels having opposed longitudinal meeting edges presenting opposed longitudinal recesses, each having opposed longitudinal recess faces, said panels collectively providing a longitudinal accessway
25 giving external access to said longitudinal recesses along substantially the length thereof when said meeting edges are in engagement; and

clamping means gripping said recess faces by a spreading action, said clamping means having a clamping
30 mode and a released mode, said clamping means being adapted when in its released mode to pass in its entirety through said accessway to a position between said recesses and to be then turned into a position occupying said opposed recesses and activated to its clamping mode gripping said
35 matching recess faces by operation of a tool passing through said accessway.



According to a third aspect of the present invention there is provided a wall structure comprising:

two side-by-side panels formed with opposed longitudinal channel grooves each having a center groove face between front and back groove faces, said panels being recessed at the front to form a front entryway to said channel grooves;

front and back elongated spreader elements having a width less than the width of said entryway and having a length greater than the distance between said center groove faces;

said front and back spreader elements bearing, respectively, against the front and back faces of said retaining grooves and the ends of the spreader elements engaging said center groove faces;

force-applying means including a screw threaded through said front spreader element and having a front head exposed to said entryway for application of a screw turning tool inserted through the entryway; and

alignment means extending between said spreader elements for maintaining them in front-to-back parallel alignment during operation of said screw;

said spreader elements being adapted to be passed together through said entryway when said spreader elements have their length extending along the length of the entryway and to be bodily turned by turning said screw until their ends engage said center groove faces, whereupon further turning of said screw spreads said spreader elements apart until they firmly engage the front and back faces of said retaining grooves.

According to a fourth aspect of the present invention there is provided a method for connecting two side-by-side panels that are formed with opposed edge grooves each having a center groove face between front and back groove faces and that provide a front entryway to said grooves;



providing a connecting unit having two spreader elements which are narrower than the entryway and longer than the distance between said center groove faces of the opposed edge grooves, and having a central screw operating
5 when turned to spread said spreader elements apart when they are restrained from turning;

passing said connector unit through said entryway to said grooves with the length of the spreader elements lengthwise of the entryway and said screw exposed to the
10 entryway;

turning the connecting unit until the ends of the spreader elements engage said center groove faces, thereby restraining the spreader elements from further turning;

turning said screw with a tool passing through
15 the entryway such as to spread the spreader elements apart until they firmly engage said front and back groove faces; and removing the tool.

Embodiments of the present invention provide modular floor rails which accurately define the positions
20 for the lower ends of prefabricated modular wall panels. The wall panels interfit with the floor rails such that they can be tilted into vertical position and be restrained at their lower ends by the interfit against horizontal movement both transverse and longitudinal of the floor
25 rails. While being tilted into vertical position on the floor rails, the upper ends of the wall panels clear ceiling rails which interfit with the heads of slide bolt elements provided by slide bolt units clamped to the wall panels by spreader clamps to restrain the upper ends of the
30 wall panels against transverse movement. The interfit between the heads of the slide bolt elements and the ceiling rails is such as to vertically restrain the slide bolt elements and permit relative vertical movement between the wall panels and the vertically restrained slide bolt
35 elements. As a result, the ceiling can move vertically relative to the wall panels to compensate for any ongoing



variances in the space between the top of the wall panels and the ceiling.

5 The wall panels have channel grooves along their vertical edges, and the spreader clamps firmly engage the side walls of these grooves. Additional spreader clamp units may be applied at other elevations to assist in holding the wall panels in coplanar alignment and may also be used near the lower ends of the wall panels to hold anchor hooks which interfit with the floor rails to prevent
10 the wall panels from being vertically displaced.

The exterior wall panels may be recessed along their indoors side to provide indoor accessways which extend beyond the channel grooves to an outside lip, whereas the interior wall panels are preferably spaced
15 apart at both sides to provide accessways to the channel grooves at either side of the interior walls. These accessways are used to introduce the slide bolt units, anchor hooks, and spreader clamps after the wall panels are in vertical position, and are then filled with trim strips or hanger strips, or otherwise covered. All of the joints
20 may be provided with suitable moisture barriers, insulation and moldings.

An embodiment of the spreader clamp has a pair of spreader plates held in alignment by dowels and are caused
25 to move apart by action of a screw element which is threaded through one of the spreader plates and passes freely through the other by way of a nonthreaded stem portion of reduced diameter originating at an annular stop shoulder and having an annular groove adjacent its other
30 end. Spring washers are positioned between the stop shoulder and the nonthreaded spreader plate. The spreader clamp is held in assembled relation by a C-element fitting into the annular groove in the stem portion of the screw. The screw element of the spreader clamps used to mount the
35 slide bolt and anchor hook units also passes through a mounting bracket or plate on the units which is located between the nonthreaded spreader plate and the spring



washers and does not restrict clockwise turning of the spreader plates relative to the units.

5 The spreader plates are shaped to pass through the accessways when held in an entry position and to extend into the channel grooves for the full depth thereof when turned about eighty degrees from the entry position into an operative position. Continued turning of the screw element then causes the spreader plates to move apart and firmly engage the side walls of the channel grooves. This spreading action results in compression of the spring washers. The clamping action of the spreader plates helps to vertically align the wall panels but does not pull the wall panels toward one another or push them apart. Thus the modular relationship of the wall panels established by the floor rails is not disturbed. This makes it possible to remove and substitute wall panels at will, without effecting the positions of the adjoining panels, merely by releasing the spreader clamps and the respective slide bolts and anchor hooks. The compressed spring washers maintain a firm gripping action by the spreader plates under varying conditions such, for example, as thermal changes.

15
20
25 The invention will now be further described, by way of example only, with reference to the accompanying drawings in which:

Figure 1 is an exploded perspective view of the parts of an embodiment of a spreader clamp unit;

Figure 2 is a perspective view of the spreader clamp of Figure 1 after assembly;

30 Figure 3 is a perspective view of an embodiment showing a ceiling lock assembly with its related spreader clamps in position to be moved into operative position between wall panels;

35 Figure 4 is a perspective view of the ceiling lock assembly of Figure 3 illustrating the spreader clamps moved to clamping position and a slide bolt raised into its locking position;



Figure 5 is a front elevational view of a bracket element of the ceiling lock assembly;

Figure 6 is an exploded perspective view of the parts of a floor lock assembly;

5 Figure 7 is a perspective view of the floor lock assembly of Figure 6 with its related spreader clamps in position to be moved into operative position between wall panels;

10 Figure 8 is a perspective view of the floor lock assembly showing the spreader clamps moved to clamping position;

Figure 9 is an exploded perspective view illustrating two rail sections and a related spring clip ready to be inserted;

15 Figure 10 is an exploded perspective view similar to Figure 9 illustrating two rail sections after insertion of the spring clip and showing a cup gasket and plug ready to be inserted;

20 Figure 11 is a transverse cross-sectional view through the joint between adjoining floor rail sections after installation of the cup gasket and plug;

Figure 12 is a top plan view of an exterior corner unit and related wall panels;

25 Figure 13 is a top plan view of an interior corner unit;

Figure 14 is a fragmentary perspective view of a mounting channel for fitting in an accessway between adjoining panels;

30 Figure 15 is a perspective view of a mounting clip for use in conjunction with the mounting channel;

Figure 16 is a transverse cross-sectional view through the joint between adjoining interior wall panels at the location of a spreader clamp unit associated with a mounting channel and mounting clip;

35 Figure 17 is a fragmentary front elevational view, with part of a wall panel broken away, showing the floor locking unit in operative position;



Figure 18 is a fragmentary vertical sectional view through the joint between adjoining exterior wall panels showing the ceiling lock and floor lock assemblies in operative position;

5 Figure 19 is a transverse cross-sectional view through the joint between adjoining exterior wall panels and showing a spreader clamp unit in top plan view in clamping position;

10 Figure 20 is a top plan view of a spreader clamp unit in position to be inserted through the accessway between wall panels;

Figure 21 is a front elevational view of a spreader clamp unit as in Figure 19 when turned into clamping position;

15 Figure 22 is a perspective view showing a corner floor rail section in mounted position between two straight rail sections;

Figure 23 is an exploded perspective view of parts of the curved corner rail section;

20 Figure 24 is a fragmentary perspective view illustrating a typical weather shell for use with the present invention; and

25 Figure 25 is a fragmentary perspective view corresponding to Figure 23 after installation of wall panels and showing a wall panel being tilted up into position.

Embodiments of the present invention incorporate a ceiling structure 20 having ceiling rails 21, a floor structure 22 having floor rails 23, and nonbearing wall structures including side-by-side panels 25. The ceiling structure 20 is supported in parallel spaced relationship to the floor structure as part of a weather shell structure 24 providing a foundation, roof, roughed-in utilities, and suitable external load-bearing columns 24a or narrow wall sections 24b which are preferably situated such as to limit only to a minor extent the locations of outside walls, doors and windows and leave the interior floor area



unrestricted as to layout. The floor structure 22 may
comprise a floor system with removable floor panels mounted
on pedestals in a plenum containing wiring, plumbing, and
ducts. Similarly, the ceiling structure 20 may comprise a
5 ceiling system with removable ceiling panels giving access
to an overhead plenum.

The wall panels 25 interfit with the floor rails
23 and are provided with ceiling lock assemblies 26
10 engaging the ceiling rails 21, and floor lock assemblies 28
having a hooking engagement with the floor rails 23. The
wall panels are preferably used in conjunction with corner
units 27. Basic to both the ceiling and floor lock

SECRET



assemblies are panel gripping units 30 which are also used independently as alignment clamps.

Preferably, the wall panels 25 are precision molded by well-known laid-up, twin-sheet or blow-molding techniques resulting in a rigid unit having a durable skin 25a enclosing a foam core 25b having good insulating and sound-absorbing characteristics. Each panel 25 is formed along each of its two vertical side edges with a channel groove 32 located between coplanar side edge faces 25c, 25d and is formed along its bottom edge with a positioning groove 34. For panel symmetry, the top edge of the panels may also be grooved. The vertical edge faces 25c, 25d may be interrupted by vertical keeper grooves 33.

The panels for exterior walls, designated 25x, are preferably thicker than those for interior walls, with the add-on thickness being on the exterior (outdoor facing) side and forming outer lips 25e along the vertical edges which have longitudinal edge faces 25f and extend for the full height of the panels 25x. The floor rails 23x and top and bottom positioning grooves 34x formed in the exterior walls are preferably wider than the floor rails 23 and grooves 34 for the interior panels 34. Other than width, the exterior and interior floor rails 23, 23x may be identical. They each have a generally rectangular, transverse cross section with an upper side formed with end positioning ledges 23a which are stepped above the level of an intermediate section 23b at sloped retaining shoulders 23c. The wall panels are internally recessed at the intersection of the channel grooves 32 and positioning grooves 34 to provide vertical sloped shoulders 25g which complement in slope and spacing that of the positioning shoulders 23c of the floor rails 23. The total length of each floor rail 23, 23x is the same as an established panel module and is maintained during production. In this regard, the horizontal distance between the lip edge faces 25f of each exterior panel 25x would be made slightly less than the

panel module so that there will be a narrow exterior gap 36 between adjoining panels 25x for weather stripping.

It is preferred that the floor rails 23, 23x be formed with a row of countersunk vertical holes 23d to receive nails or screws for attachment to the underlying floor structure. One or both of the side faces 23h of the floor rails 23, 23x are formed at their ends with horizontal anchor slots 38 to receive the floor lock assemblies 28. The anchor slots 38 preferably slope upwardly within the floor rails. It will be apparent that the floor rails 23, 23x may be made to a length equal to multiple of the panel modules, in which case the resulting interior ledges 23a would have double width longitudinally of the rails. There is no need for the ceiling rails 21 to be modular in length.

To assist in aligning the floor rails 23 and 23x during initial layout on the floor, and allowing a loose initial assembly of all of the floor rail sections to assure location of all elements, the floor rail sections are fastened to the floor unit, the end ledges 23a thereof are each provided with a transverse slot 23e adjacent the shoulder 23c and a pair of shallower longitudinal slots 23f extending from the ends of the transverse slot to the respective end of the floor rail section. These slots 23e, 23f of adjoining floor rail sections are adapted to receive a wire spring clip 39 having depending U-sections 39a at its ends joined by tension links 39b. The U-sections are shaped to occupy the transverse slots 23e at adjoining ends of the two floor rail sections and the tension links 39b are located to occupy the related longitudinal slots 23f. The spacing of the transverse slots 23e slightly exceeds the length of the tension links 39b so that they will be tensioned when the U-sections 39a are pressed downwardly into the transverse slots 23e.

It will be noted that the ends of the floor rail sections have semicylindrical recesses 23g at their ends so that two end-to-end floor rail sections provide a cylindri-

cal pocket for receiving a cup gasket 41. This cup gasket is pressed firmly into sealing relation with the related floor rail sections and underlying weatherstripping by use of a rigid tapered plug 41a which is forced downwardly within the cup gasket.

When two of the interior wall panels 25 are properly positioned side-by-side on floor rails 23, the adjoining side edge faces 25c-25c and 25d-25d are spaced apart to provide respective accessways 42 at opposite sides of the panels which give access to the corresponding grooves 32. Similarly, when two of the exterior wall panels 25x are properly positioned side-by-side on floor rails 23x, the adjoining side edge faces 25c-25c are spaced apart to provide an accessway 42x at the indoor side of the panels. The lips 25c on the exterior side of the panel 25x block the outer end of the space between side edge faces 25d of adjoining exterior panels 25x so that it functions as an extension 43 of accessway 42x.

The panel gripping units 30 include a pair of front and back clamping plates 44F, 44B with outside gripping faces 44a which are preferably formed with gripping teeth 44b or other suitable gripping elements for engaging and gripping the opposite side faces 32a, 32b of the vertical panel grooves 32 in the interior or exterior panels. The front plate 44F has a central threaded bore 46 which aligns with a central bore 47 of lesser diameter in the back plate 44B. Alignment means is provided in the form of a pair of diagonally opposite dowels 48 projecting forwardly from the back plate 44B to register with holes 50 through the front plate 44F. Each gripping unit 30 is completed by a screw 52, C-ring 54, and a pair of Belleville spring washers 56.

The screw 52 has a threaded head portion 52a formed at its forward end with a flat-sided recess 52b for receiving a complementing tool. The opposite end of the screw 52 is preferably also recessed to receive a suitable screw driver. Behind the head portion 52a, the screw 52 is

stepped at a shoulder 52c to a rear stem portion 52d which is formed with an annular groove adjacent its rear end for receiving the C-ring 54.

To assemble a gripping unit 30, the screw may be passed rearwardly through the bore 46 in the front plate 44F and screwed into the bore 46 only partway along the length of the threaded portion 52a. Then the screw is passed through center openings 56a in the spring washers and through the bore 47 in the back plate 44B, while the dowels 48 are registered with the front openings 50. The spring washers 56 are then confined on the stem portion 52d between the shoulder 52e and the front face of the back plate 44B, and the rear portion of the stem portion projects rearwardly behind the back plate 44B sufficiently to expose the groove 52c so that the C-ring 54 can be applied thereto to hold the assembly together.

Clamping plates 44F, 44B are generally a parallelogram in shape and the width thereof between longitudinal edges 44a, 44b is less than the width of the accessways 42, 43, whereas the length thereof between end edges 44c, 44d measured parallel to the longitudinal edges 44a, 44b exceeds the width of the accessways 42, 43. It will also be noted that the two diagonally opposite apexes 44e, 44f of the plates 44F, 44B, which are in the lead when the gripping unit 30 is turned clockwise as viewed from the front, are the closer of the four apexes to the center of the plates 44F, 44B and have their noses rounded.

A pair of the clamping units 30 are used as part of each ceiling lock assembly 26 and one of the clamping units is incorporated in each anchoring unit 28. Referring to a ceiling lock assembly, it is seen that it has a mounting bracket 58 and a slide bolt 60. The mounting bracket 58 comprises an elongated vertical plate 58a having horizontal top and bottom flanges 58b, 58c with aligned openings 58h, 58i for receiving the slide bolt 60. C-rings 59 filling into annular grooves in the slide keep the slide

bolt and bracket 58 in assembled relation before and during installation.

The mounting plate 58a and bottom flange 58c are narrower than the accessways between panels so that they can pass therethrough, and the top flange 58b is preferably wider than the mounting plate 58 and accessways so that it can rest on top of adjoining panels. Along its vertical edges, the mounting plate 58 is formed with vertically staggered pairs of notches 58d, 58e. The mounting plate also has a pair of central openings 58f, 58g located midway between the two notches of each pair of notches. The spacing and arrangement of the notches 58d, 58e and openings 58f correspond to those of the dowels 48 and central opening 47 in the back plates 44B of the clamping units 30 so that the dowels can occupy the notches when a pair of the clamping units are mounted on the mounting bracket 58, with their screws passing through the bracket openings 58f, 58g and the mounting plate 58a positioned between the back clamping plate 44B and spring washers 56 of each clamping unit. For such an assembly, the spacing between the shoulder 52d and annular groove 52a of the clamping screws 52 is increased by the thickness of the mounting plate 58a. It will be noted that the arrangement of the pairs of notches 58d, 58e is such that the clamping units can be turned clockwise relative to the mounting bracket 58.

The slide bolt 60 has a spherical head 60a adapted to have a snap interfit with a central locking channel 62 extending along the ceiling rail and having opposed bottom gripping lips 62a. As an alternative, the head of the slide bolt can be given a cross section similar to that of the locking channel 62, and the locking channel can be given a suitable cross section similar to that of the head 60a. The interfit between the head of each slide bolt and the related ceiling rail holds the slide bolts against vertical movement relative to the ceiling and leaves the ceiling structure and slide bolts free to float

relative to the wall panels by way of the sliding fit between the slide bolts and the brackets 58. This compensates for any ongoing variances in the space between the top of the wall panels and the ceiling.

5 Referring to the floor lock assemblies 28, each has a hook plate 64 formed with an upper vertical mounting section 64a, a forwardly sloped central section 64b, a front vertical section 64c, and a bottom, upwardly sloping, terminal hook section 64d adapted to fit into adjoining
10 anchor slots 38 of floor rail sections 23. The upper mounting section 64a is formed with a central slot 64e and notches 64f, 64g in its opposite edges. The hook plate 64 receives one of the clamping units 30, with the screw passing through the slot 64e and the mounting section 64a
15 located between the back clamping plate 44B and the spring washers 56. The dowels 48 of the clamping unit occupy the notches 64f, 64g when the length of the clamping plates 44F, 44B is aligned with the length of the hook plate 64. The arrangement of the notches permits the clamping plates
20 to then be turned clockwise relative to the hook plate. Thus, a floor lock assembly 28 can be inserted through the accessway between two adjoining wall panels and the hook 64d fitted into the anchor slots 38 of the underlying floor rail sections preparatory to locking the clamping unit 30
25 of the floor lock assembly in place by turning its screw 52.

It is preferable to provide at the exterior corners of the building structure non-load-bearing interior and exterior corner units 27, 27x comprising molded
30 intermediate sectors 71 and end sections 72 connected together at weatherproof joints. The end sectors have their outer longitudinal end walls formed to the same configuration as the vertical side edges of the wall panels
25 so that the panels adjoining the corner units can be secured to the corner post by clamping units 30 and to the floor and ceiling rails by ceiling and floor lock
35 assemblies 26, 28 at the joints between the corner



post units and the adjoining wall panels. The number of intermediate sectors 71 can be varied to vary the corner angle. The corner units 27, 27x are basically the same except that in the case of the interior corners, the longitudinal end walls will be narrower to match in size and configuration the vertical side edges of the interior wall panels 25. It is preferred to provide curved floor rail sections 73 (Figure 21) to fit between the ends of the straight floor rail sections 23 adjoining the corners and to provide the lower ends of the corner units 27, 27x with grooves to interfit with these corner curved floor rail sections 73 in the same manner as the wall panels interfit with the other floor rail sections 23. The curved floor rail sections 73 may be molded as a single piece or may comprise multiple intermediate segments 73a fitting between end pieces 73b. Each intermediate segment 73a encompasses an angle module, such as, for example, $7\frac{1}{2}$ or 15 degrees, so that multiple of the segments can be selected to form the desired corner angle. The segments 73a each present a tongue 73c at one side and a matching socket 73d at the opposite side for interfitting the segments. Alternate of the pieces 73b are formed at their inner end with a tongue 73c or socket 73d to interfit with the selected intermediate segments 73a. Mating vertical holes 73e, 73f are provided for passing nails 73g through the tongues 73c and into the underlying floor structure.

Referring to Figures 14-16, the accessways between the wall panels may be covered by trim strips 74, which have longitudinal feet 74a which snap-fit into the grooves 33. The accessways can also house mounting channels 76 for holding shelf or cabinet brackets, for example. Each mounting channel 76 has a back T-slot 76a for slidably receiving clips 78, having a handle 78a at one end and an opening 78b at its other end for fitting over the screw 52 of one of the clamping units 30. The back wall of the mounting channel 76 is formed with openings 76b for receiving the head end portion of the screw 52 of clamps 30.

With this arrangement, a mounting channel 76 can be connected by clips 78 to two or more clamping units 30, and then the mounting channel 76, clips 78 and clamping units 30 can be inserted as a unit into one of the accessways while the clamping units have the longer dimension of their clamping plates 44F, 44B extending vertically. Then the clamping units 30 can be turned and engaged with the wall panels in the same manner as previously described by turning the screws 52, which are accessible through the front of the mounting channel.

Suitable weatherstripping gaskets 80, 81 are placed between the floor rail sections 25, 73 and the underlying floor structure and between the bottom edge of the wall panels 25 and the top of the floor rail sections. Also, suitable moisture-resistant insulation is placed between the tops of the external wall panels 25x and the ceiling rails, and in the extensions 43 of the accessways 42x of the exterior wall panels. Gaskets may also be placed between the opposed joint faces 25f of adjoining exterior wall panels.

Preliminary to installing walls according to the invention, the layout for the floor rail sections 23, 73 is planned and marked, and preferably is computer justified. The installation steps are then as follows:

1. The floor rail sections 23, 73 are located on the floor with bottom weatherstripping 80 in place and are connected together by way of the spring clips 39, following which the floor rail sections are fastened to the floor structure.
2. The ceiling rail is located and installed using a plumb-bob to the floor rail and corner members.
3. The weatherstripping cup members 41 and gasket strips 81 are applied.
4. The wall panels 25, 25x are tilted up in place using the floor rails as jig guides.
5. The ceiling lock assemblies 26 are installed.

6. Joint insulation is installed between the wall panels.

7. Clamp units 30 are applied at one or more mid-panel locations.

5 8. the floor lock assemblies 28 are installed.

9. Panel-to-ceiling insulation is inserted.

10. Face trim is installed between the panels.

11. Ceiling trim 82 is installed.

To later remove a wall panel for substitution, 10 for example, of another panel containing a window, it is only necessary to remove the face trim to gain access to the ceiling lock assemblies 26, floor lock assemblies 28, and intermediate clamp units 30. In each instance, the screws 52 are unscrewed sufficiently to loosen the clamping 15 plates 44f, 44b and turn them into vertical position for removal through the accessways 42, 42x after the slide bolts 60 have been lowered free of the ceiling rail and the anchor hook elements 64d have been loosened from the floor rail slots 38. The wall panel is then free to be tilted 20 out of vertical position and removed without disturbing the adjoining panels.

It will be apparent that entire walls can be easily removed and relocated by removing the wall panels as above described, relocating the related floor rail and 25 ceiling rail sections, and reinstalling the wall panels. Depending upon the change in floor plan, additional wall panels and floor rail and ceiling rail sections may, of course, be required.

The described embodiments provide a wall system 30 making it possible to use and interchange precision-molded wall panels without any hardware having to be attached thereto for use, and making it possible to easily release and replace a wall panel without disturbing adjacent panels and without requiring access from the top or both sides of 35 the panels.



THE CLAIMS DEFINING THE INVENTION ARE AS FOLLOWS:

1. A building structure comprising:

a floor structure;

5 a ceiling structure;

a support structure between the floor structure and ceiling structure for supporting the latter;

10 a wall structure between the ceiling structure and the floor structure which does not support the ceiling structure, said wall structure including a row of side-by-side wall panels, said panels being spaced by a gap beneath said ceiling structure and interfitting with the floor structure such as to be removable when tilted from a vertical position;

15 extendible means operable between adjacent said wall panels for interfitting with said ceiling structure when engaged for holding said panels in vertical position when the wall panels interfit with said floor structure; and

20 panel gripping means operable between adjacent said wall panels when engaged for holding the wall panels against movement relative to one another, said wall panels having accessways therebetween to said extendible means and panel gripping means for operation thereof;

25 said extendible means and panel gripping means being adapted to be moved through said accessways and to be engaged and disengaged by a tool inserted through said accessways when a cover means is removed therefrom, whereby each of said wall panels may be individually installed and
30 removed without moving adjacent wall panels.

2. A building structure according to claim 1, wherein said accessways extend along substantially the full vertical length of the panels.

35



3. A building structure according to claim 1 or claim 2, wherein there are more than one of said panel gripping means between adjoining panels, and said extendable means is carried by two of said panel gripping means.

5

4. A building structure according to any preceding claim in which an anchor foot interfits with said floor structure and is carried by one of said panel gripping means.

10 5. A building structure according to any preceding claim in which a removable cover means interfits with said panels and covers said accessways.

6. A wall structure comprising:

15 a pair of coplanar panels having opposed longitudinal meeting edges presenting opposed longitudinal recesses, each having opposed longitudinal recess faces, said panels collectively providing a longitudinal accessway giving external access to said longitudinal recesses along
20 substantially the length thereof when said meeting edges are in engagement; and

clamping means gripping said recess faces by a spreading action, said clamping means having a clamping mode and a released mode, said clamping means being adapted
25 when in its released mode to pass in its entirety through said accessway to a position between said recesses and to be then turned into a position occupying said opposed recesses and activated to its clamping mode gripping said matching recess faces by operation of a tool passing
30 through said accessway.

7. A wall structure according to claim 6, wherein the accessway extends along substantially the full vertical length of the panels.

35



8. A wall structure according to claim 6 or claim 7 in which said recesses comprise opposed grooves extending the full length of said panels and presenting said matching recess faces, said clamping means including a pair of
5 spreader elements and a cooperating screw operative when turned in one direction to spread said spreader elements into said clamping mode, and operative when turned in the opposite direction to retract said spreader elements into said released mode, said screw being exposed to said
10 accessway for engagement by said tool.

9. A wall structure according to claim 8 in which compression spring means is sleeved on said screw and urges said spreader elements apart.
15

10. A wall structure comprising:
two side-by-side panels formed with opposed longitudinal channel grooves each having a center groove face between front and back groove faces, said panels being
20 recessed at the front to form a front entry way to said channel grooves;

front and back elongate spreader elements having a width less than the width of said entryway and having a length greater than the distance between said center groove
25 faces;

said front and back spreader elements bearing, respectively, against the front and back faces of said retaining grooves and the ends of the spreader elements engaging said center groove faces;
30

force-applying means including a screw threaded through said front spreader element and having a front head exposed to said entryway for application of a screw turning tool inserted through the entryway; and

alignment means extending between said spreader
35 elements for maintaining them in front-to-back parallel alignment during operation of said screw;

said spreader elements being adapted to be passed



together through said entryway when said spreader elements have their length extending along the length of the entryway and to be bodily turned by turning said screw until their ends engage said center groove faces, whereupon
5 further turning of said screw spreads said spreader elements apart until they firmly engage the front and back faces of said retaining grooves.

11. A wall structure according to claim 10, wherein the
10 entryway extends along substantially the full vertical length of the panels.

12. A wall structure according to claim 10 or claim 11,
15 wherein compression spring means is carried by said force applying means and is compression loaded when said spreader elements engage said front and back faces.

13. A method for connecting two side-by-side panels that are formed with opposed edge grooves each having a center
20 groove face between front and back groove faces and that provide a front entryway to said grooves:

providing a connecting unit having two spreader elements which are narrower than the entry way and longer than the distance between said center groove faces of the
25 opposed edge grooves, and having a central screw operating when turned to spread said spreader elements apart when they are restrained from turning;

passing said connector unit through said entryway to said grooves with the length of the spreader elements
30 lengthwise of the entryway and said screw exposed to the entryway;

turning the connecting unit until the ends of the spreader elements engage said center groove faces, thereby restraining the spreader elements from further turning;

35 turning said screw with a tool passing through the entryway such as to spread the spreader elements apart until they firmly engage said front and back groove faces;



and

removing the tool.

14. A wall structure according to any one of claims 6 to
5 9, wherein the clamping means is a clamp comprising:

front and back gripping elements having gripping
faces;

a screw pin having a front threaded section, a head
adapted to interfit with a turning tool, a shoulder
10 rearwardly of the threaded section and facing the back
gripping element, and a nonthreaded stem section to the
rear of the threaded section;

a central threaded hole through said front gripping
element interfitting with said front threaded section;

15 a nonthreaded hole through said back gripping
element freely receiving said stem section;

an alignment pin projecting from one of said
gripping elements and slidably interfitting with the other
gripping element;

20 and means on said stem section for preventing
separation of said gripping element to the extent that said
alignment pin is disengaged from its interfit with said
other spreader element.

25 15. A wall structure according to claim 14, wherein a
compression spring is sleeved on said stem section between
said shoulder and back gripping element.

16. A wall structure according to claim 15, wherein said
30 gripping elements comprise spreader plates of generally
parallelogram configuration having outer gripping faces.

17. A wall structure according to claim 16, wherein
35 diagonally opposite apexes of said spreader plates are
rounded.



18. A structure substantially as hereinbefore described with reference to the accompanying drawings.

19. A method for connecting two side-by-side panels
5 substantially as hereinbefore described with reference to the accompanying drawings.

10

Dated this 19th day of December 1991

ROBERT L PROPST

By DAVIES COLLISON CAVE

15 Patent Attorneys for the applicant(s)

SECRET



36450/89

FIG. 1

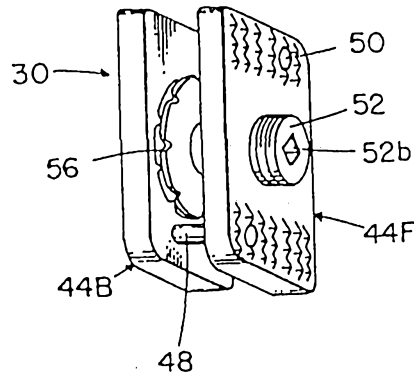
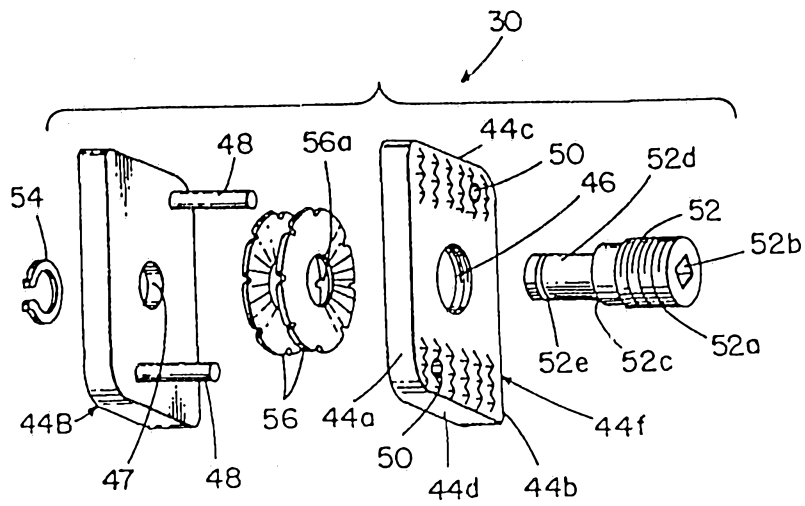

FIG. 2

FIG.3

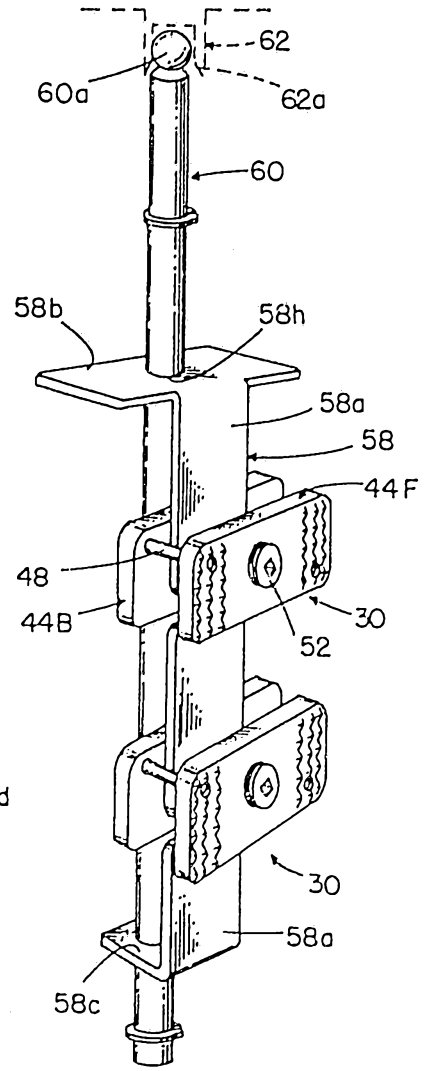
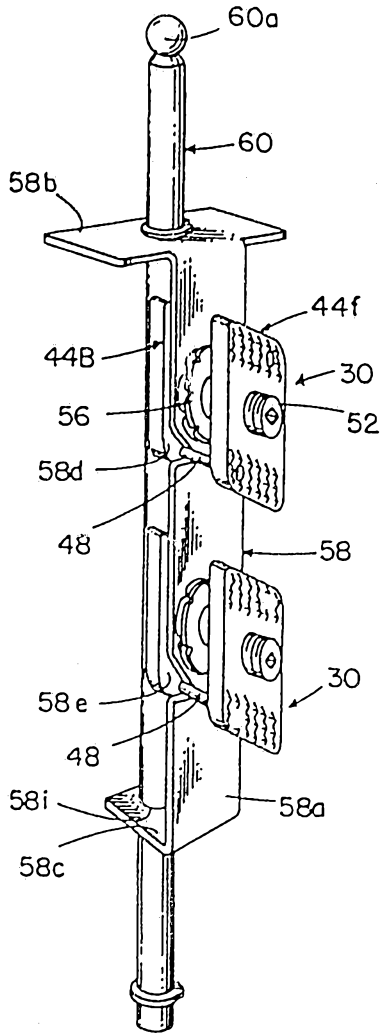

FIG.5

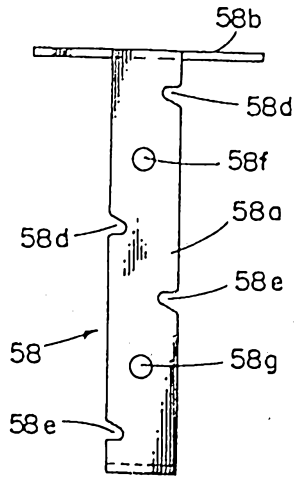

FIG.4

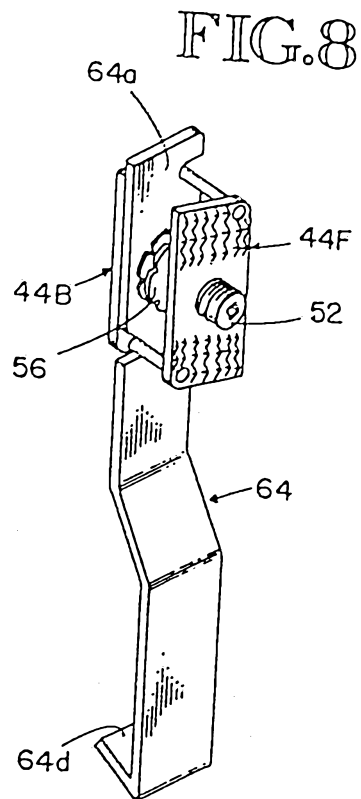
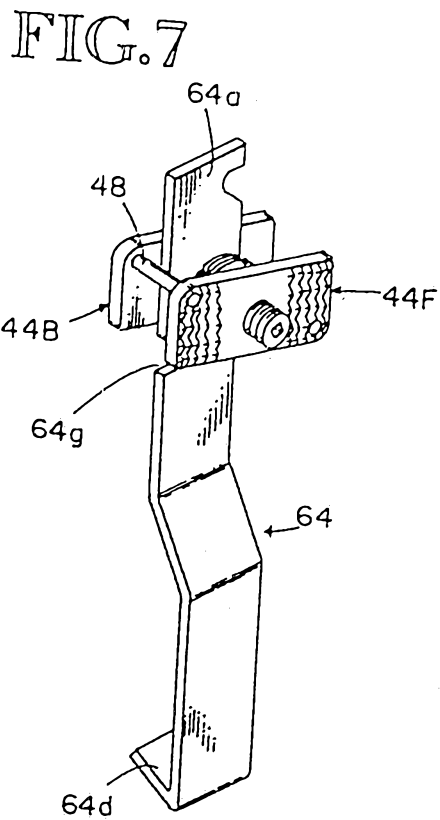
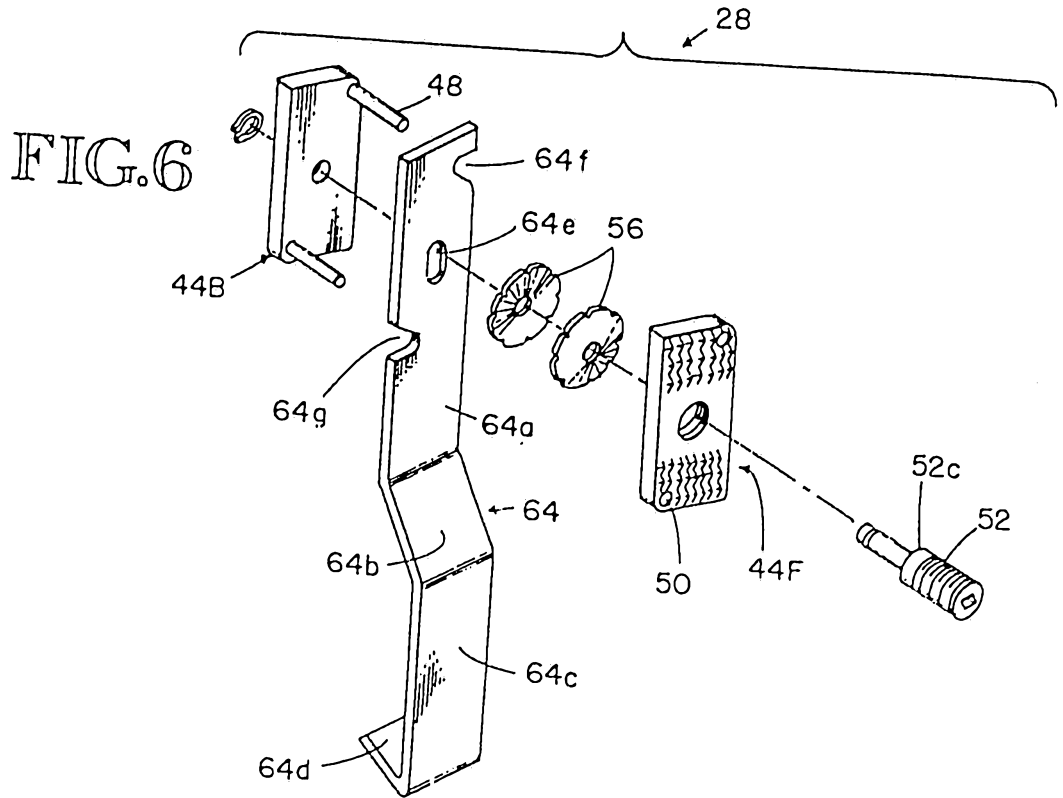

FIG.9

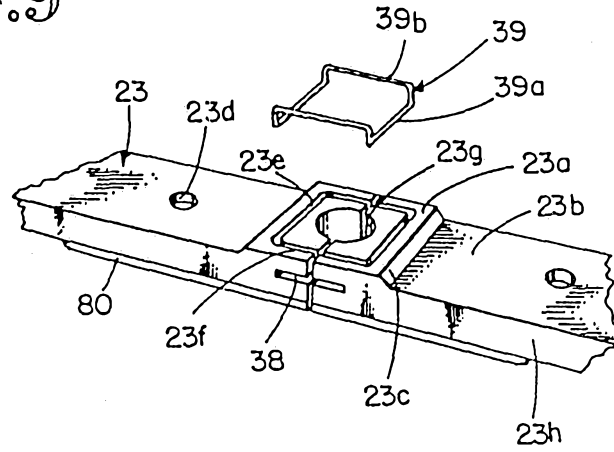

FIG.10

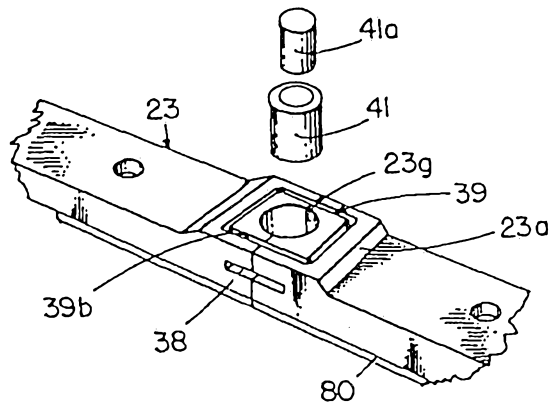

FIG.11

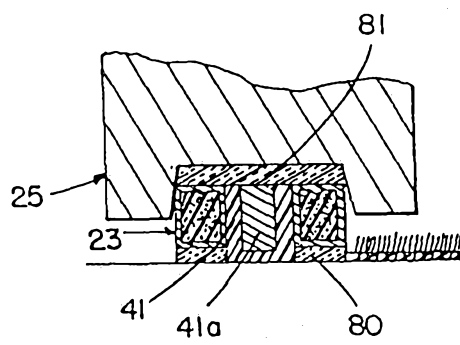

FIG.12

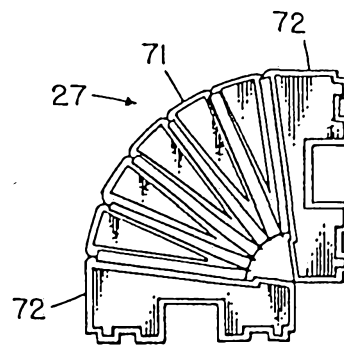
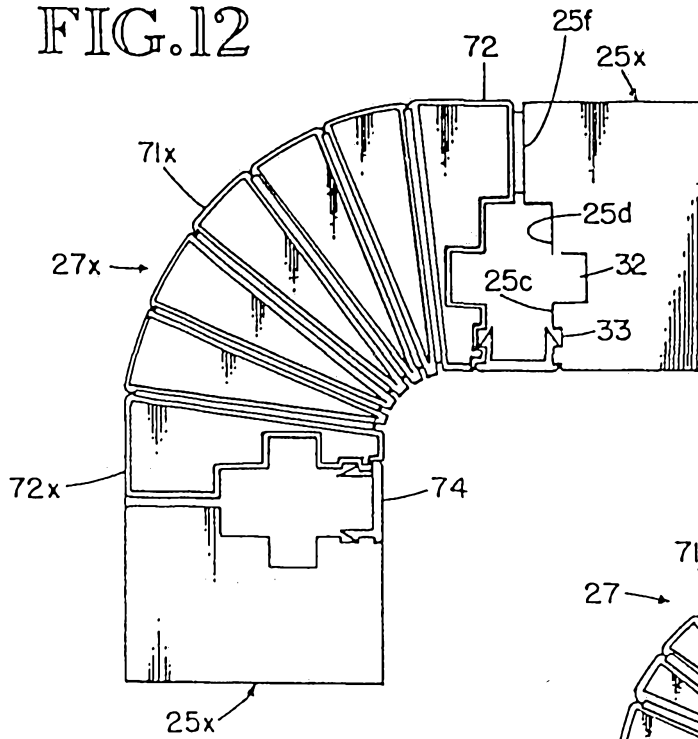

FIG.13

FIG. 16

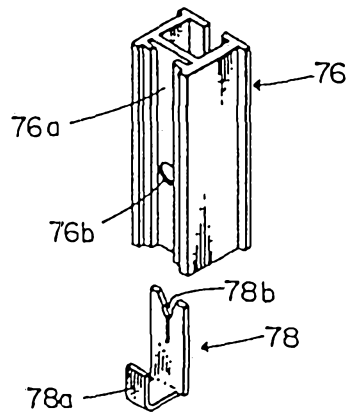
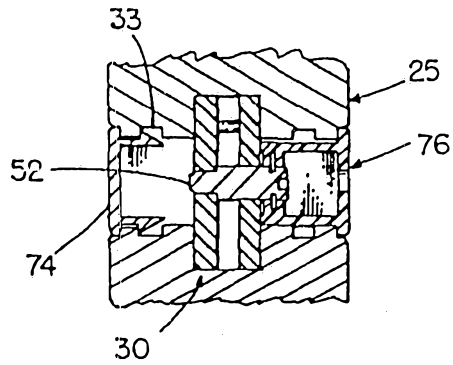
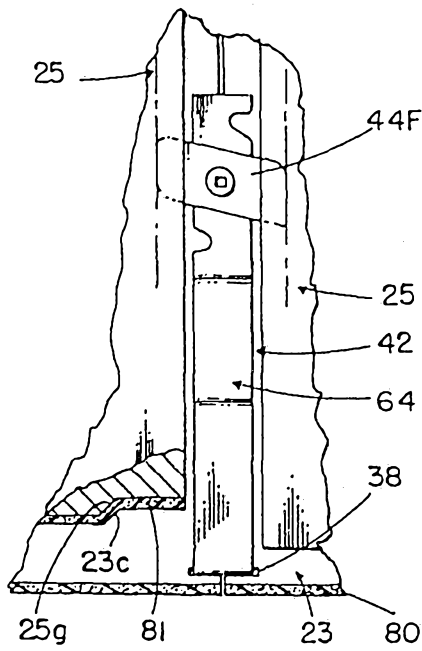

FIG. 14

FIG. 15

FIG. 17



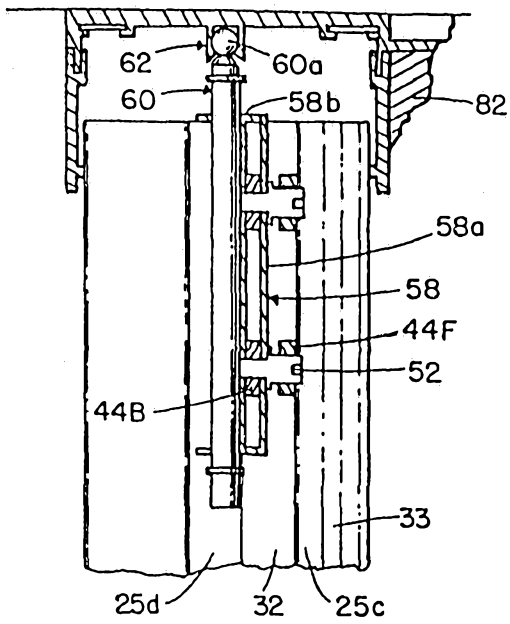

FIG. 18

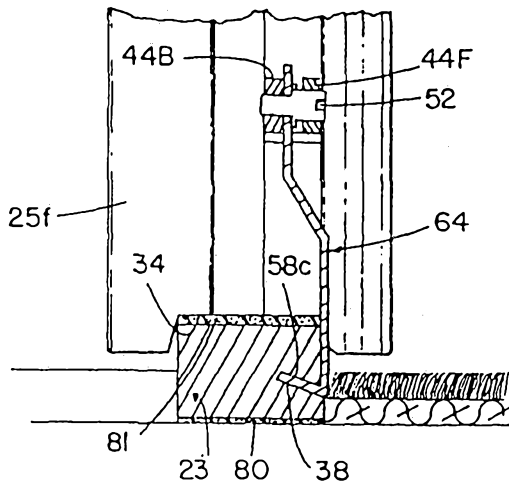

FIG. 19

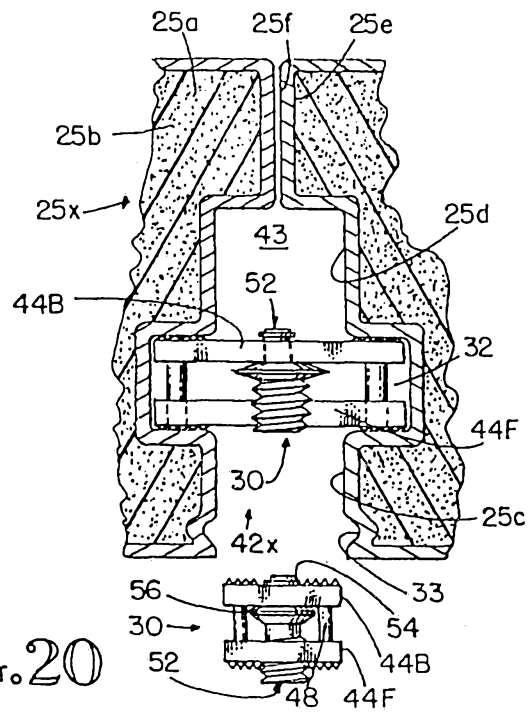

FIG. 21

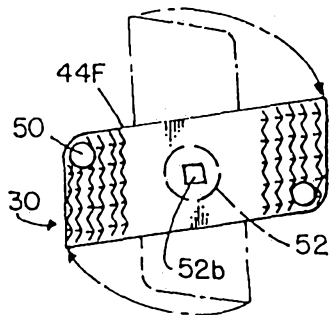

FIG. 20

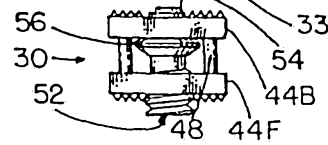

FIG.22

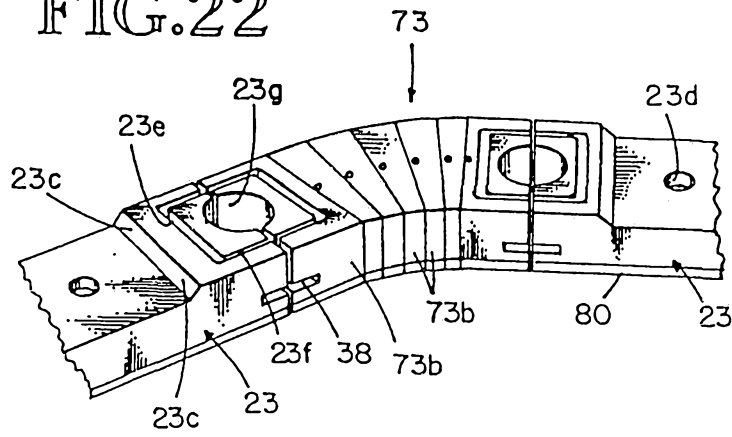
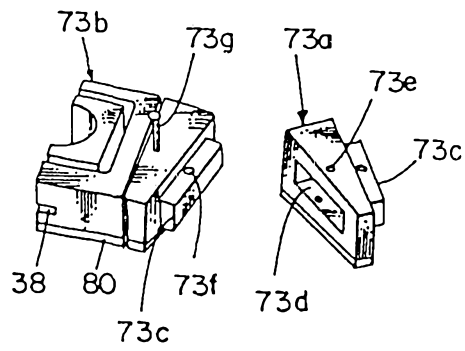

FIG.23



36450/89

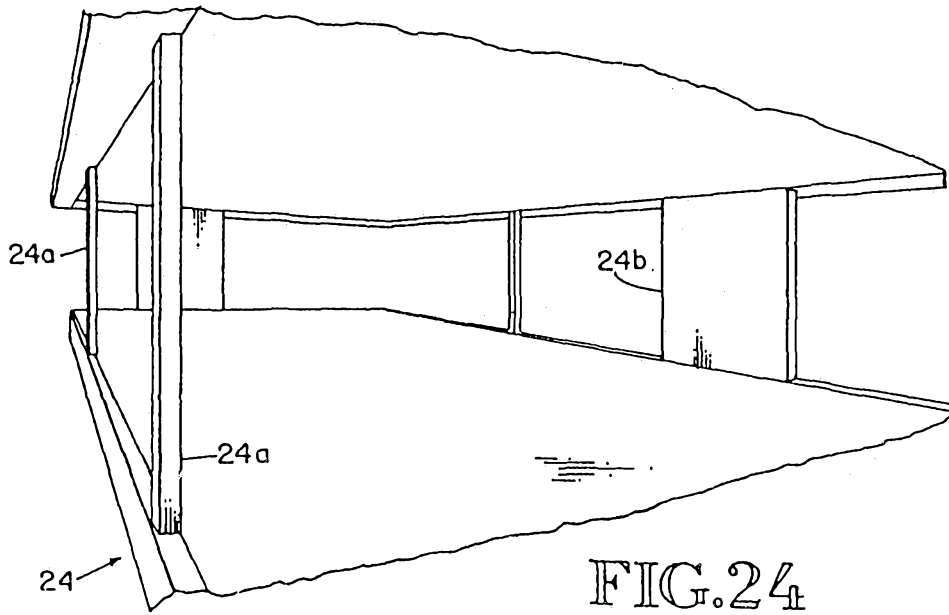

FIG. 24

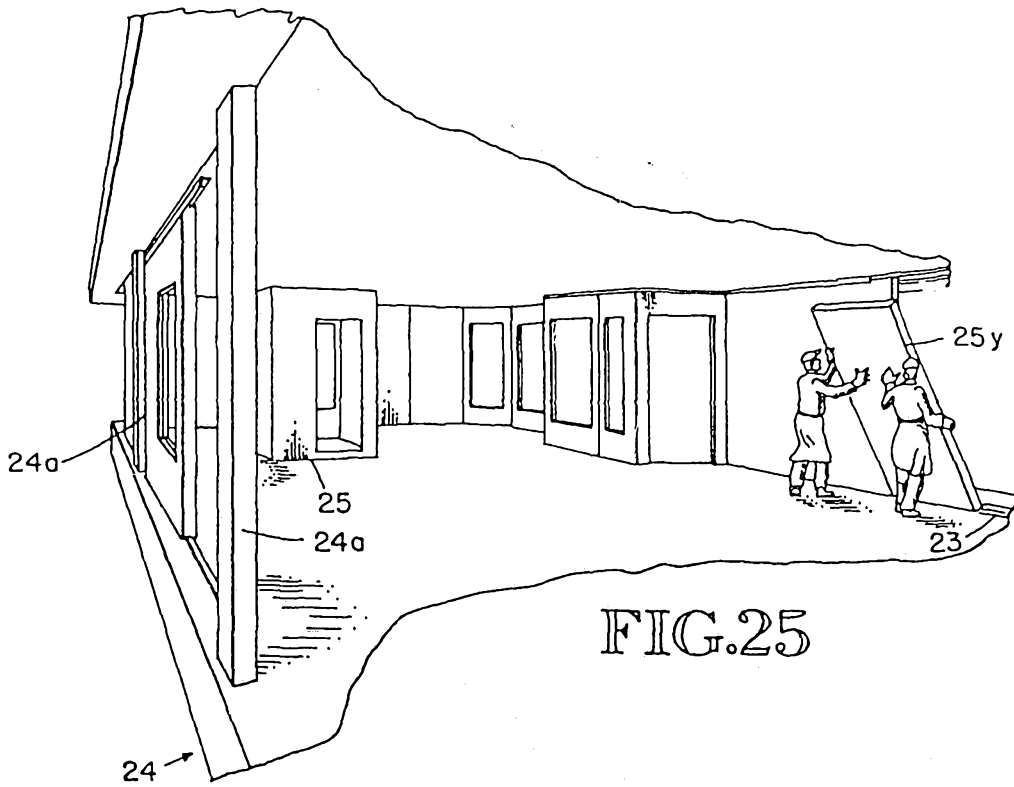

FIG. 25

