

(12) UK Patent Application (19) GB (11) 2 175 222 A

(43) Application published 26 Nov 1986

(21) Application No 8613923

(22) Date of filing 5 Jul 1985

Date lodged 9 Jun 1986

(30) Priority data

(31) 8508892 (32) 4 Apr 1985 (33) GB

(60) Derived from Application No 8517799 under Section 15(4) of the Patents Act 1977

(71) Applicant
Thule United Limited (United Kingdom),
South College Street, Aberdeen, Scotland

(72) Inventor
Marshall Graham Bailey

(74) Agent and/or Address for Service
Keith W. Nash & Co., 90-92 Regent St.,
Cambridge CB2 1DP

(51) INT CL⁴
B07B 1/46

(52) Domestic classification (Edition H):
B1D 1804 1819 1821 1902 1903 1911 2101 2301 PG
B2H 34

(56) Documents cited
GB 1578948

(58) Field of search
B1D
B1T
B2H
Selected US specifications from IPC sub-classes B01D
B07B

(54) Filtering screen

(57) A filtering screen comprises a first filter mesh, a second filter mesh having a different mesh size from the first and overlying the first mesh, and an apertured support to which both of the meshes are bonded so as to maintain the two meshes in tension, the tension in one of the meshes being greater than that in the other. At least one other filter mesh may be bonded over the first two meshes. The support comprises a rectilinear frame 64,66,72 divided by transverse bars 68 and reinforced by additional rods (70). The screen is used in a vibrating screening machine.

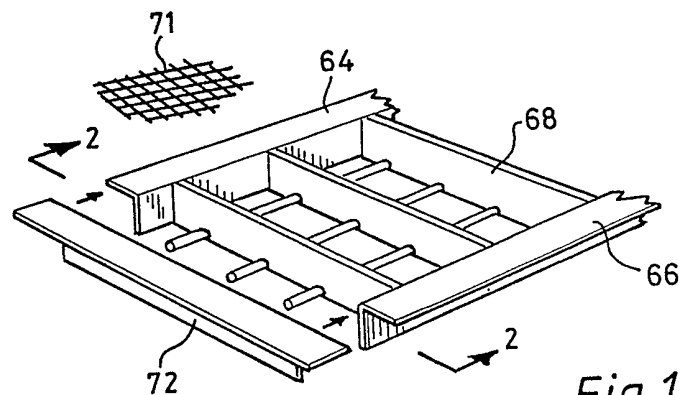

Fig.1

The drawings originally filed were informal and the print here reproduced is taken from a later filed formal copy.

This print embodies corrections made under Section 117(1) of the Patents Act 1977.

The date of filing shown above is that provisionally accorded to the application in accordance with the provisions of Section 15(4) of the Patents Act 1977 and is subject to ratification or amendment.

GB 2 175 222 A

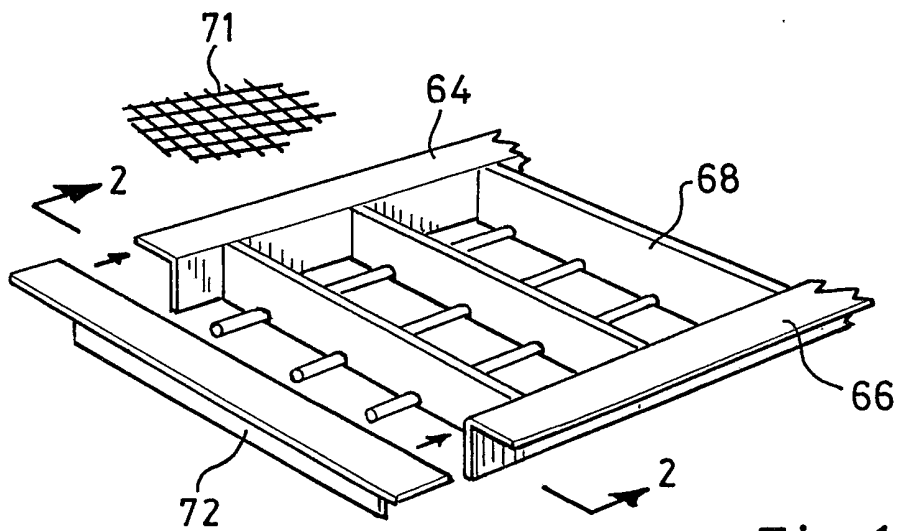

Fig. 1

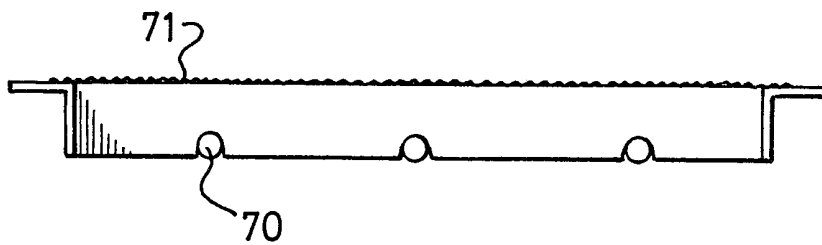

Fig. 2

SPECIFICATION

Improvements in filtering screens5 *Field of the invention*

This invention relates to a screen for use in a filtering process, especially for filtering a particle-containing suspension or a slurry.

10 *Background to the invention*

Commonly, in filtering processes generally of the kind referred to, a plurality of differently-sized mesh filter elements are mounted one above the other in a vibratory cradle or the like. Each wire mesh screen may be tensioned across the cradle by use of fixing hooks. Alternatively, each single mesh screen may be mounted and possibly stretched within a screen insertable into the cradle.

20 *Object of the invention*

It is an object of this invention to provide an improved filtering screen, for example a filtering screen which can usefully be employed in a vibratory cradle.

25

Summary of the invention

According to one aspect of the present invention, a filtering screen comprises:

- a) a first filter mesh,
- 30 b) a second filter mesh having a different mesh size from the first and overlying the first mesh, and
- c) an apertured support to which the meshes are bonded so as to maintain the two meshes in tension, the tension in one of the meshes being
- 35 greater than that in the other, wherein
- d) the screen support is in the form of a rectangular frame of rigid supports similar to a picture frame with transversely extending intermediate struts to define apertures within the frame.

40 The invention is not limited to the use of only two screen meshes and additional meshes having the same or different mesh size and having the same or different tension may be incorporated by bonding over the first two mentioned meshes.

45 By incorporating a rigid apertured support and bonding the meshes to the support, so differential tensions within the meshes can be maintained and the meshes are kept flat even under load thereby preventing migration of slurry and uneven distribution across the screen.

50 Where meshes or cloths are to be secured to an apertured support as aforesaid, the bonding may be achieved using a thermosetting adhesive, a chemically setting adhesive, or by fusion where the rigid support is of an appropriate material such as a plastics material.

55 There is no limitation on the material which can be used for the rigid screen support. Thus for example any of wood, steel, plastics or a composite material including fibres for reinforcement may be used, or any combination thereof.

60 As is known, the use of two meshes of differing tension overlying one another enables the screen to be self-cleaning. By providing a rigid support to which the meshes or filter cloths are bonded, the

self-cleaning aspect of the invention is enhanced since the meshes or screen cloths do not need to be tensioned to the same extent as is the case if they are to be self supporting.

70 In one embodiment of the invention a polyester is used to bond the mesh to a relatively rigid support of glass reinforced plastics material.

The support preferably has a regular pattern of apertures.

75 The meshes or screen cloths are preferably formed from woven wire.

Typical mesh sizes are 12 wires per cm (30 wires per inch) and 60 wires per cm (150 wires per inch), the coarser mesh always being the mesh which is in contact with the support and the finer mesh (60 wires per cm) being secured over the coarser mesh.

80 Bonding of the meshes to the support may be aided by the application of heat and pressure applied by a press or by means of rollers.

85 The differential tensioning imparted during bonding allows one mesh to flap against the other during vibration so as to render the screen self-cleaning.

90

Description of drawings

The invention will now be described, by way of example, with reference to the accompanying drawings, in which:

95 *Figure 1* illustrates in perspective part of a practical embodiment of screen support; and *Figure 2* is a cross-section through *Figure 1* on the line 2-2.

100 *Detailed description of drawings*

In *Figure 1* a screen support is shown comprising angled members 64 and 66 between which extend rigid bars such as 68, typically welded at their ends. As shown in *Figure 2* each bar is cut away on its underside to accommodate transversely extending rods such as 70. Also as shown in *Figure 2*, the upper surface of the bars 68 and the out turned flanges of the members 64 and 66 are coplanar and two or more meshes typically of woven wire as at 71 can be stretched over the frame and secured to the coplanar surfaces of the members 64, 66 and 68 using a suitable adhesive.

110 The frame may be completed by means of members such as 72 which again may be welded or otherwise secured to the side struts 64 and 66.

115 The screen described herein is intended to be firmly clamped in a vibratory screening machine, in use.

120 CLAIMS

1. A filtering screen comprising:
 - a) a first filter mesh,
 - b) a second filter mesh having a different mesh
 - 125 size from the first and overlying the first mesh, and
 - c) an apertured support to which the meshes are bonded so as to maintain the two meshes in tension, the tension in one of the means being greater than that in the other, wherein
 - 130 d) the screen support is in the form of a recti-

linear frame of rigid supports similar to a picture frame with transversely extending intermediate struts to define apertures within the frame.

2. A filtering screen as claimed in claim 1, in which at least one other filter mesh is bonded over the first two meshes.

3. A filtering screen as claimed in claim 1 or claim 2, wherein the bonding agent is a thermosetting adhesive or a chemically setting adhesive.

4. A filtering screen comprising:

support constituted by a rectilinear structure defining an outer frame and intermediate struts defining apertures within the frame,
a first filter mesh,

a second filter mesh having a different mesh size from the first and overlying the first mesh,
wherein the meshes are bonded to the support so as to maintain the meshes in tension, with the tension in one mesh greater than that in the other.

5. A filtering screen as claimed in claim 4, wherein the support has longitudinal outer frame members, transversely extending intermediate bars, and longitudinally extending intermediate rods assisting rigidity.

6. A filtering screen as claimed in claim 5, wherein the side members and intermediate bars have coplanar upper surfaces and the at least two meshes are stretched over the frame and bonded to said coplanar surfaces with the required differential tensions.

7. A filtering screen as claimed in claim 5 or claim 6, wherein the longitudinal side members comprise angled members providing upper surfaces of substantial area to which the meshes are bonded.

8. A filtering screen as claimed in claim 7, wherein the outer frame is completed by transverse angled members secured to the longitudinal angled members, said transverse angled members also providing upper surfaces of substantial area.

9. A filtering screen as claimed in claim 5 or any claim appendant to claim 5, wherein the intermediate rods are accommodated in aligned cut away regions on the undersides of the transversely extending intermediate bars.

10. A filtering screen substantially as hereinbefore described with reference to the accompanying drawings.