



US007532677B2

(12) **United States Patent**
Simon

(10) **Patent No.:** **US 7,532,677 B2**
(45) **Date of Patent:** **May 12, 2009**

(54) **APPARATUS, SYSTEMS AND METHODS FOR PRODUCING COHERENT SYMBOLS IN A SINGLE FREQUENCY NETWORK**

(75) Inventor: **Michael Simon**, Frederick, MD (US)

(73) Assignee: **Rohde & Schwarz GmbH & Co., KG**, Munich (DE)

(*) Notice: Subject to any disclaimer, the term of this patent is extended or adjusted under 35 U.S.C. 154(b) by 430 days.

(21) Appl. No.: **11/276,453**

(22) Filed: **Feb. 28, 2006**

(65) **Prior Publication Data**

US 2007/0223612 A1 Sep. 27, 2007

Related U.S. Application Data

(60) Provisional application No. 60/740,424, filed on Nov. 29, 2005, provisional application No. 60/657,416, filed on Mar. 2, 2005.

(51) **Int. Cl.**
H04L 5/12 (2006.01)

(52) **U.S. Cl.** **375/265; 375/354**

(58) **Field of Classification Search** **375/265, 375/354**

See application file for complete search history.

(56) **References Cited**

U.S. PATENT DOCUMENTS

6,005,605 A	12/1999	Kostreski et al.	
6,130,898 A	10/2000	Kostreski et al.	370/522
6,269,092 B1	7/2001	Schilling	
6,313,885 B1	11/2001	Patel et al.	348/725
6,477,180 B1	11/2002	Aggarwal et al.	370/468

6,480,236 B1	11/2002	Limberg	348/555
6,772,434 B1	8/2004	Godwin	
7,110,048 B2	9/2006	Weiss	348/723
7,382,838 B2 *	6/2008	Peting	375/327
2002/0001349 A1	1/2002	Bretl et al.	
2002/0097336 A1	7/2002	Oshima	348/487
2002/0140867 A1	10/2002	Weiss	
2003/0099303 A1	5/2003	Birru et al.	
2003/0201932 A1	10/2003	Rabinowitz et al.	
2004/0062283 A1	4/2004	Takeuchi et al.	
2004/0160344 A1	8/2004	Bretl et al.	
2004/0237024 A1 *	11/2004	Limberg	714/784
2004/0240460 A1	12/2004	Hwang et al.	370/412

(Continued)

FOREIGN PATENT DOCUMENTS

WO 2004062283 A1 7/2004

(Continued)

OTHER PUBLICATIONS

Wang, "A new implementation of single frequency network based on DMB-T", 2004 International Conference on Communications, Circuits and Systems, 2004, ICCAS 2004, vol. 1, Jun. 27-29, 2004 pp. 246-249 vol. 1.*

(Continued)

Primary Examiner—Juan A Torres

(74) Attorney, Agent, or Firm—Fitzpatrick, Cella, Harper & Scinto

(57) **ABSTRACT**

A system, method, apparatus and computer code are provided for producing coherent symbols from digital RF transmitters. A receiver receives a first initialization packet containing a plurality of stuff bytes and Trellis coders are deterministically initialized using the first initialization packet.

85 Claims, 9 Drawing Sheets

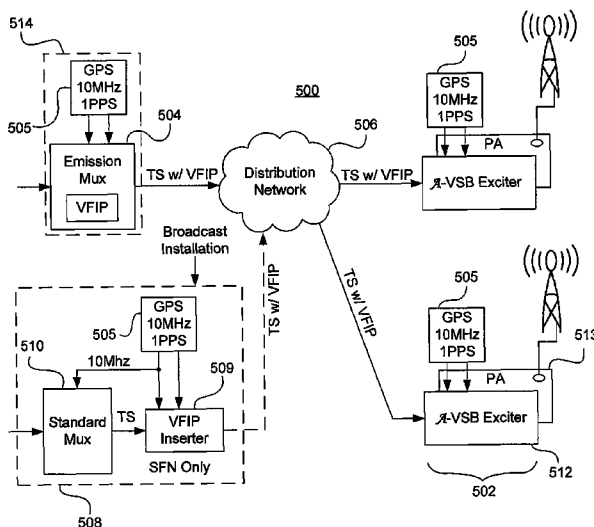

U.S. PATENT DOCUMENTS

2005/0013249	A1	1/2005	Kong et al.	370/235
2005/0074074	A1 *	4/2005	Limberg	375/285
2005/0249300	A1 *	11/2005	Jeong et al.	375/265
2005/0249301	A1 *	11/2005	Jeong et al.	375/265
2005/0259643	A1	11/2005	Chuah et al.	370/389
2006/0088023	A1 *	4/2006	Muller	370/350
2006/0200852	A1	9/2006	Simon	725/118
2006/0200853	A1	9/2006	Simon	725/118
2006/0244865	A1	11/2006	Simon	348/614
2006/0245516	A1	11/2006	Simon	375/295
2006/0246836	A1	11/2006	Simon	455/3.01
2007/0066272	A1	3/2007	Vassiliou et al.	

FOREIGN PATENT DOCUMENTS

WO 2006/094054 9/2006

OTHER PUBLICATIONS

Battista, "Spectrally efficient high data rate waveforms for the UFO SATCOM channel", Military Communications Conference, 1998, MILCOM 98. Proceedings, IEEE vol. 1, Oct. 18-21, 1998 pp. 134-139 vol. 1.*

International Search Report and Written Opinion of the International Searching Authority, PCT/US06/20599, Aug. 31, 2007.

International Search Report and Written Opinion of the International Searching Authority, PCT/US06/07265, Sep. 4, 2007.

International Preliminary Report on Patentability and Written Opinion of the International Searching Authority, PCT/US2006/022300, Dec. 27, 2007.

International Preliminary Report on Patentability and Written Opinion of the International Application, PCT/US2006/007265, Nov. 1, 2007.

"ATSC Standard: Synchronization Standard for Distributed Transmission (A/110)", Advanced Television Systems Committee (Jul. 14, 2004).

"ATSC Standard: Synchronization Standard for Distributed Transmission, Revision A (A/110A)", Advanced Television Systems Committee (Jul. 19, 2005).

Whitaker, J. C., "Standard Handbook of Video and Television Engineering", Chapter 17.2 "ATSC DTV Received Systems", pp. 17-63 to 17-99 (2000).

"Lecture 4: Digital Television The DVB transport stream", obtained from <http://www.abo.fi/~jbjorkqv/digitv/lect4.pdf> (last visited May 4, 2006).

Wang, X. et al., "Transmitter Identification in Distributed Transmission Network and Its Applications in Position Location and a New Data Transmission Scheme", NAB Broadcast Engineering Conference, Las Vegas, NV, p. 511-520 (Apr. 16-21, 2005).

Vogel, W. J., et al., "Propagation Effects and Satellite Radio Design", Paper No. 1445, Maastricht Exhibition and Congress Centre (MECC) Maastricht, the Netherlands (Aug. 17-24, 2002).

Patel, C. B., et al., "Proposal to ATSC Subcommittee T3/S9 to Provide 8-VSB with a Repetitive-PN1023 Signal For Rapidly and Reliably Initializing Tracking in an Adaptive Equalizer Despite Adverse Multipath Conditions" (Apr. 12, 2001).

Raghunandan, K., "Satellite Digital Audio Radio Service (SDARS) System Architecture and Receiver Review", IEEE (Oct. 27, 2005).

Owen, H., "Proposed Modifications to ATSC Digital Television Standard to Improve Performance in the Face of Dynamic Multipath for both Fixed and Mobile Operation", Sarnoff Corporation, Princeton, NJ (Apr. 2, 2001).

"ATSC Technology Group Report: DTV Signal Reception and Processing Considerations", Doc. T3-600r4, Advanced Television Systems Committee (Sep. 18, 2003).

Proposal for Enhancement of ATSC RF Transmission System (Revision to A/53), submitted by Samsung, Draft ver. 1.0 (Sep. 16, 2004).

Citta, R., et al., "ATSC Transmission System: VSB Tutorial", Zenith Electronics Corporation, Symposium Handout, Montreux Symposium (Jun. 12, 1997).

"ATSC Recommended Practice: Design of Synchronized Multiple Transmitter Networks (A/111)", Advanced Television Systems Committee (Sep. 3, 2004).

Lee, Y., et al., "ATSC Terrestrial Digital Television Broadcasting Using Single Frequency Networks", ETRI Journal, vol. 26, No. 2, pp. 92-100, Apr. 2004.

"ATSC Digital Television Standard (A/53) Revision E", Advanced Television Systems Committee (Dec. 27, 2005).

International Search Report and Written Opinion of the International Searching Authority, PCT/US06/015317, May 14, 2008.

International Search Report and Written Opinion of the International Searching Authority, PCT/US06/07251, May 20, 2008.

"Digital Video Broadcasting (DVB); DVB mega-frame for Single Frequency Network (SFN) synchronization", European Broadcasting Union, ETSI TS 101 191 v1.4.1 (Jun. 2004).

* cited by examiner

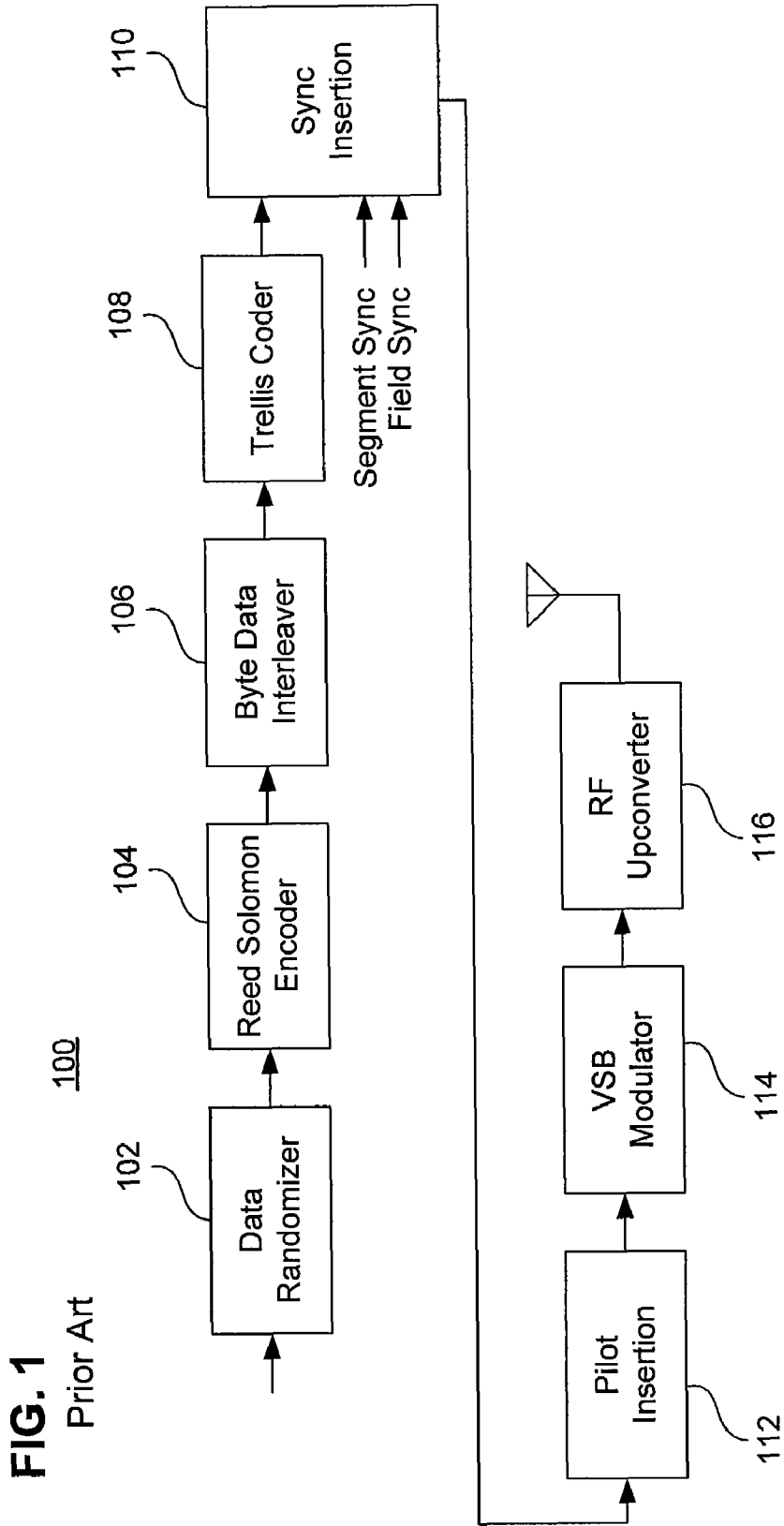

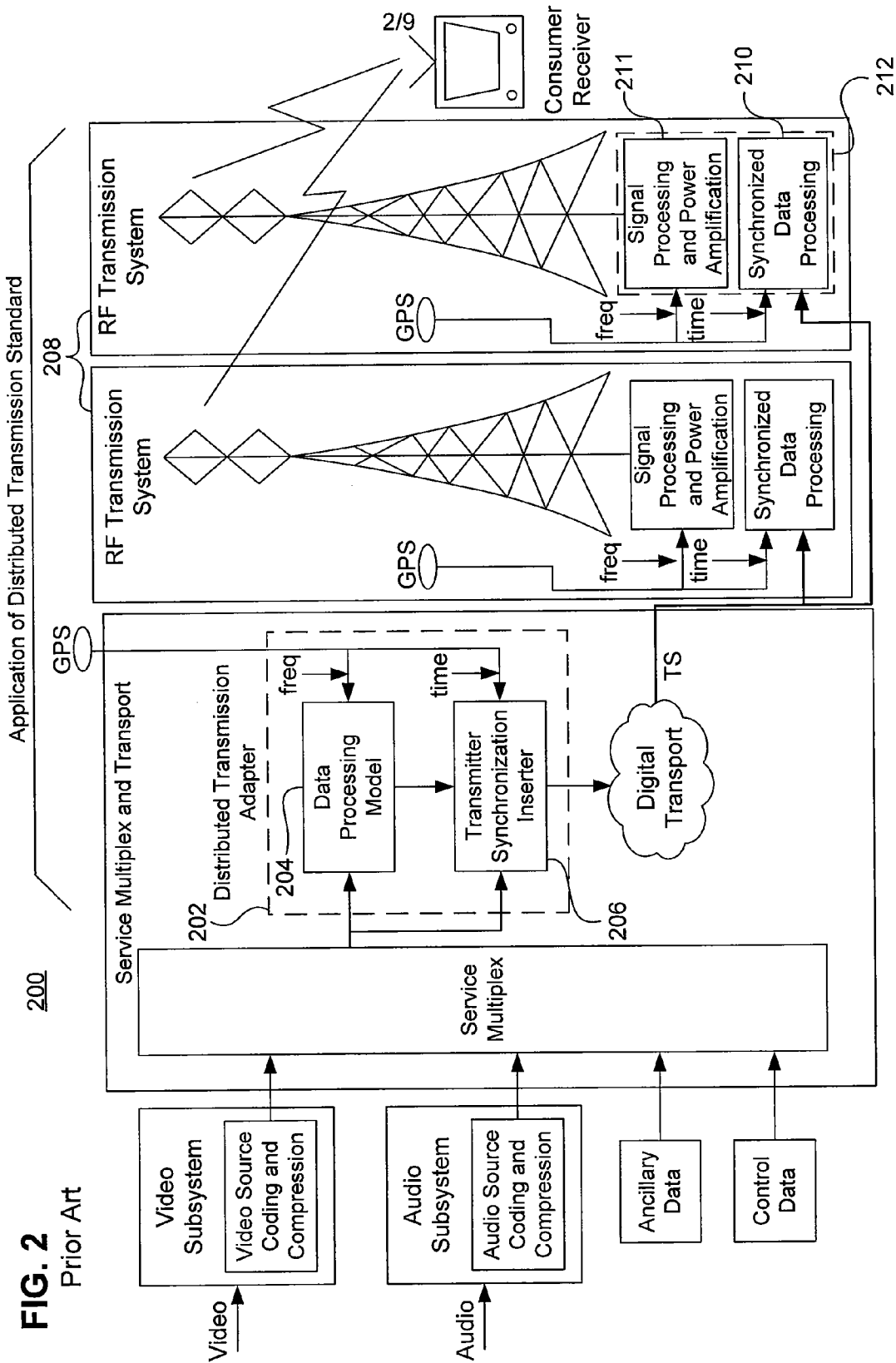

FIG. 2
Prior Art

FIG. 3
Prior Art

Syntax	No. of Bits	Format
DTx_packet (){		
reserved	8	0xFF
for (i=0; i<12; i++) {		
trellis_code_state	8	riuimsbfpw
}		
synchronization_time_stamp	24	uimsbf
maximum_delay	24	uimsbf
network_identifier_pattern	12	uimsbf
stream_locked_flag	1	bslbf
reserved	1	'1'
packet_number	10	uimsbf
reserved	32	0xFFFFFFFF
tx_group_number	8	uimsbf
for (i=0; i<16; i++) {		
tx_address	12	uimsbf
tx_identifier_level	3	uimsbf
tx_data_inhibit	1	bslbf
tx_time_offset	16	tcimsbf
tx_power	12	uipfmsbf
reserved	4	'1111'
}		
reserved	320	for (i=0; i<40; i++) 0xFF
DTxP_ECC	160	uimsbf
}		

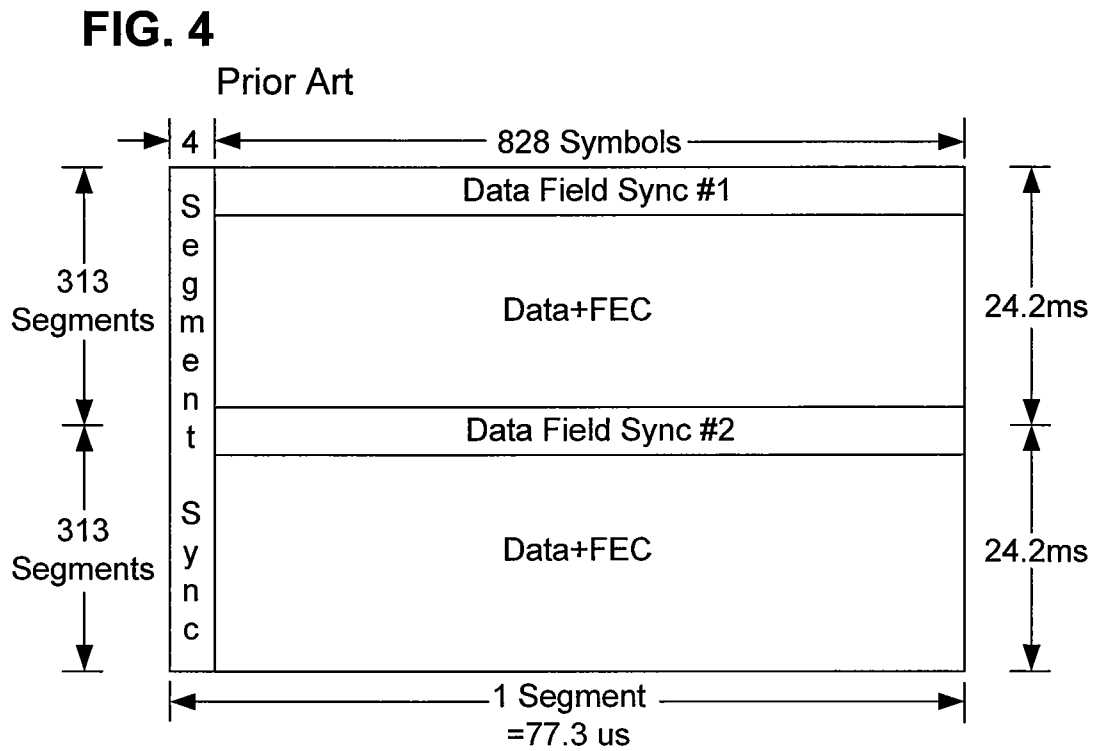

FIG. 5

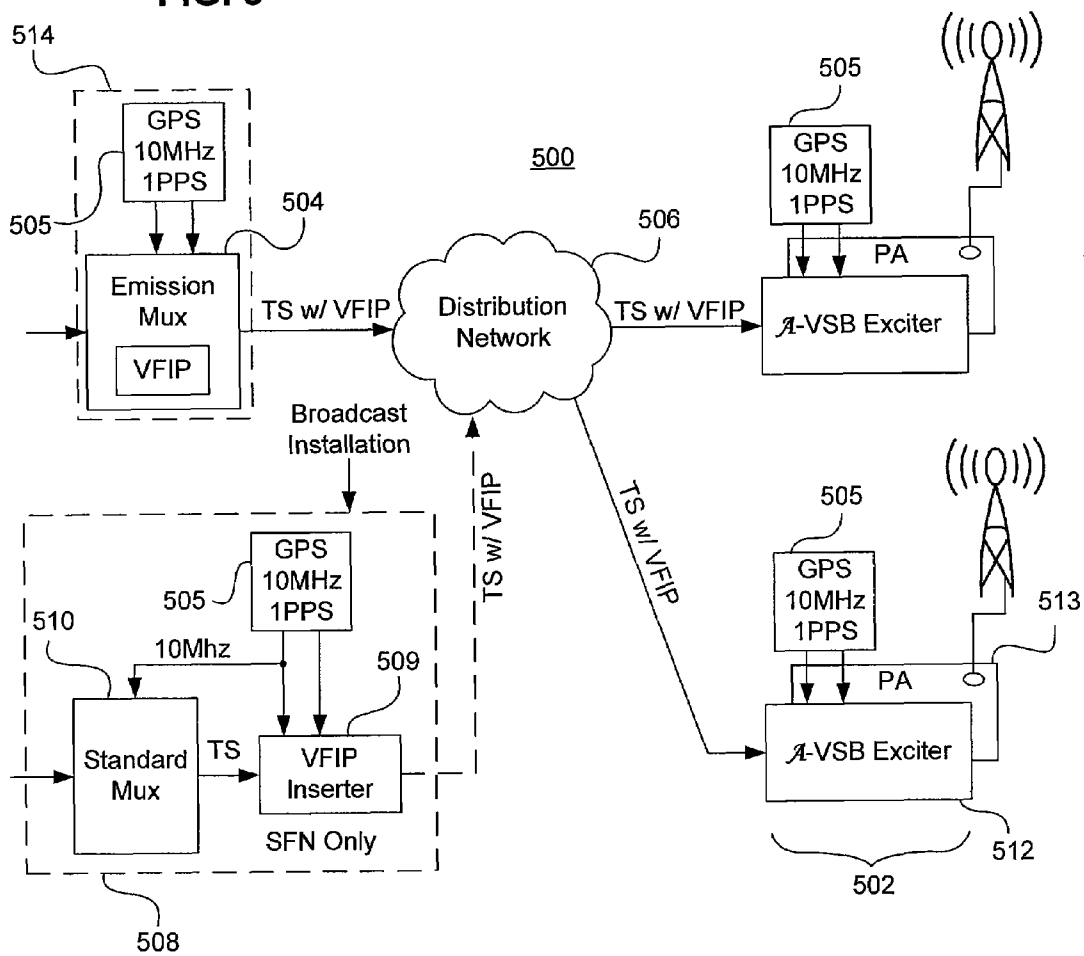

FIG. 6

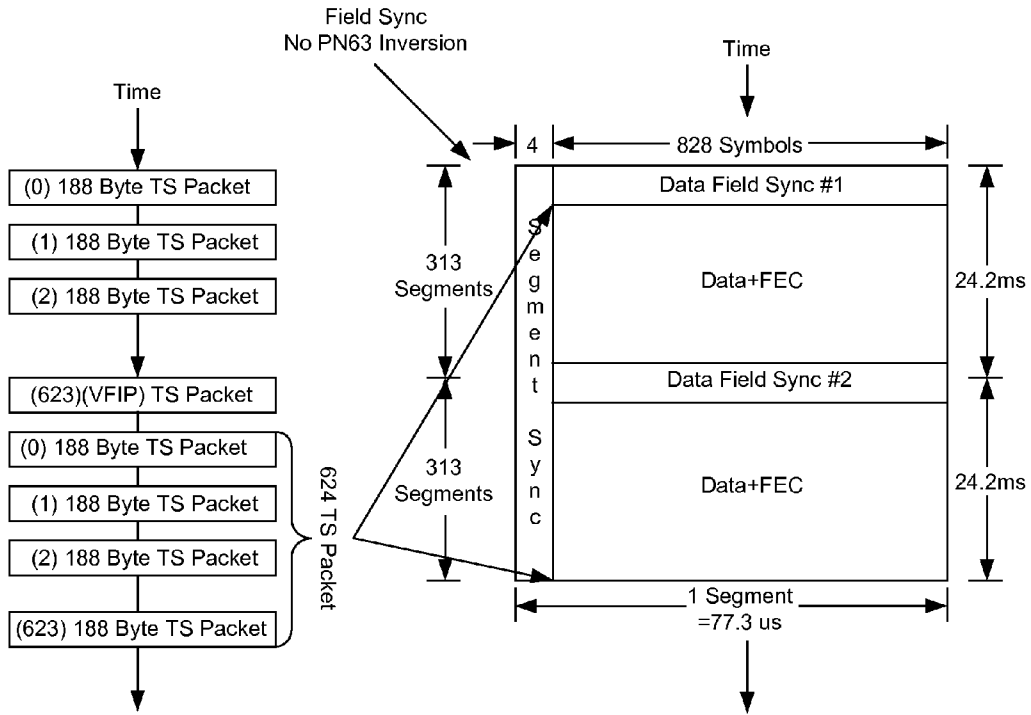
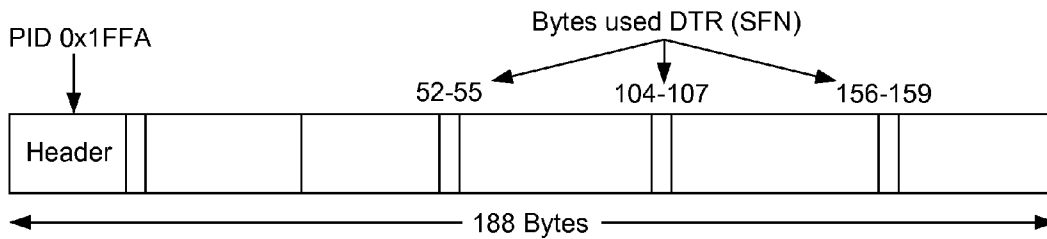
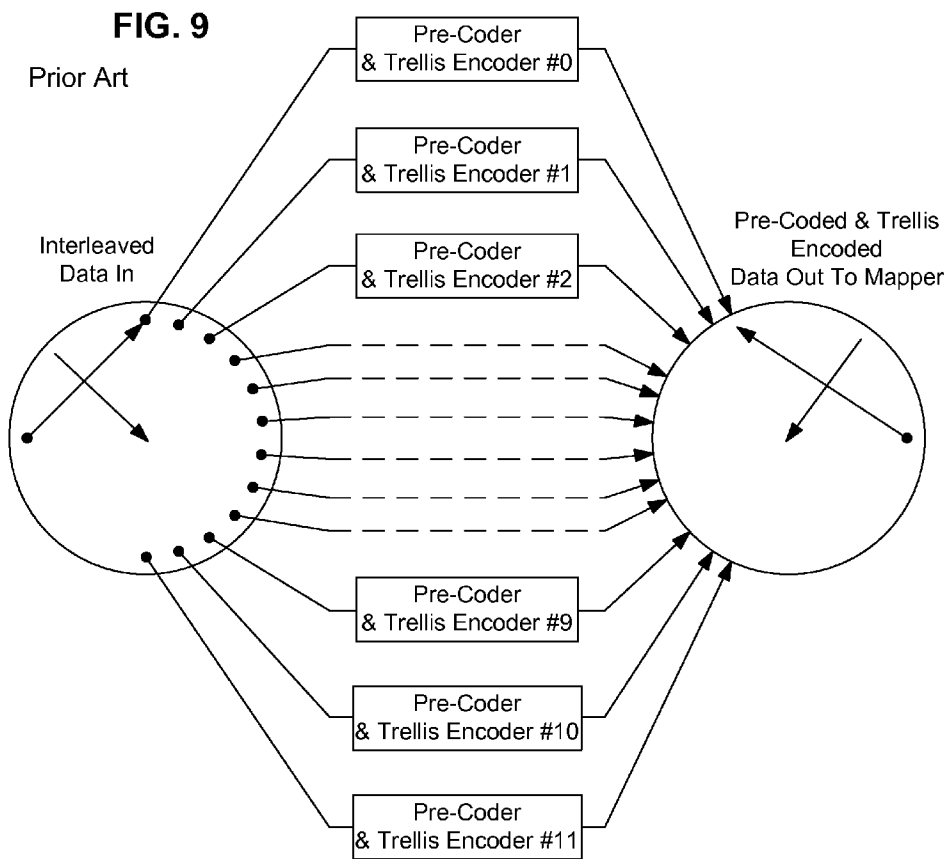
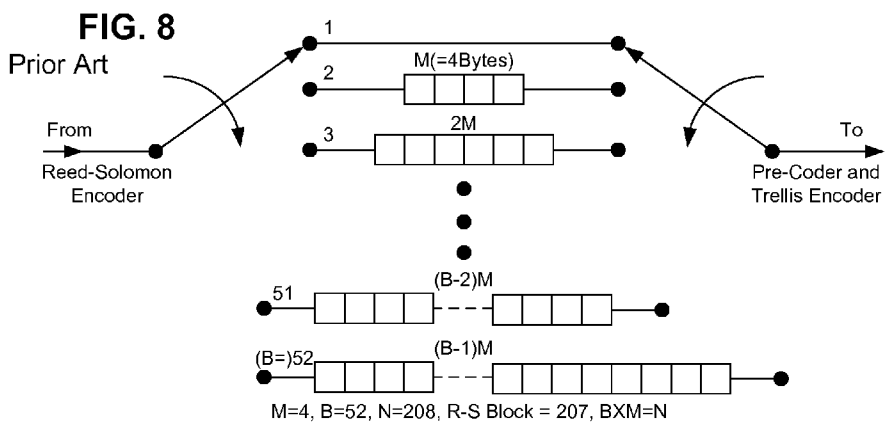

FIG. 7





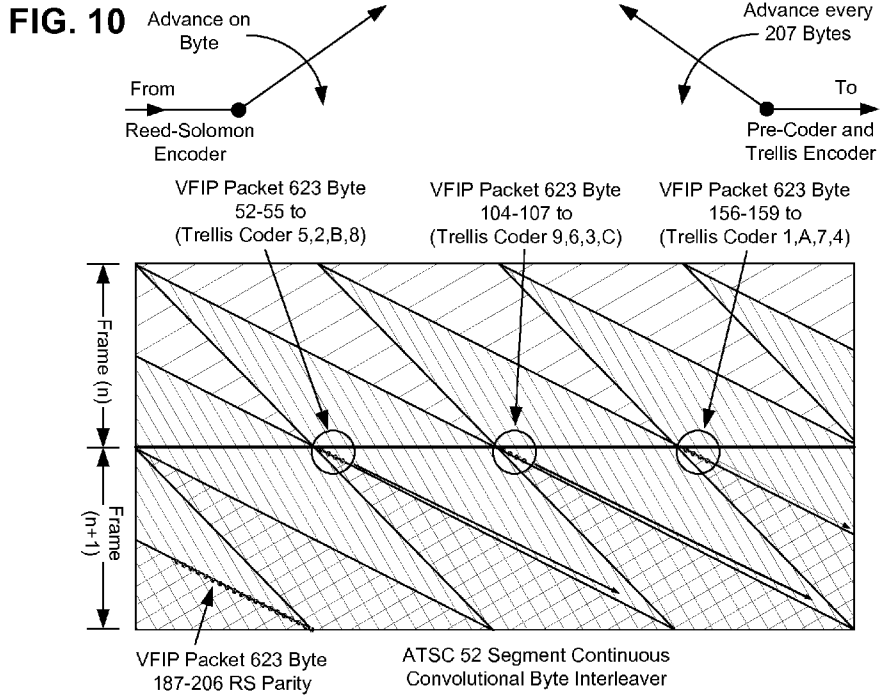
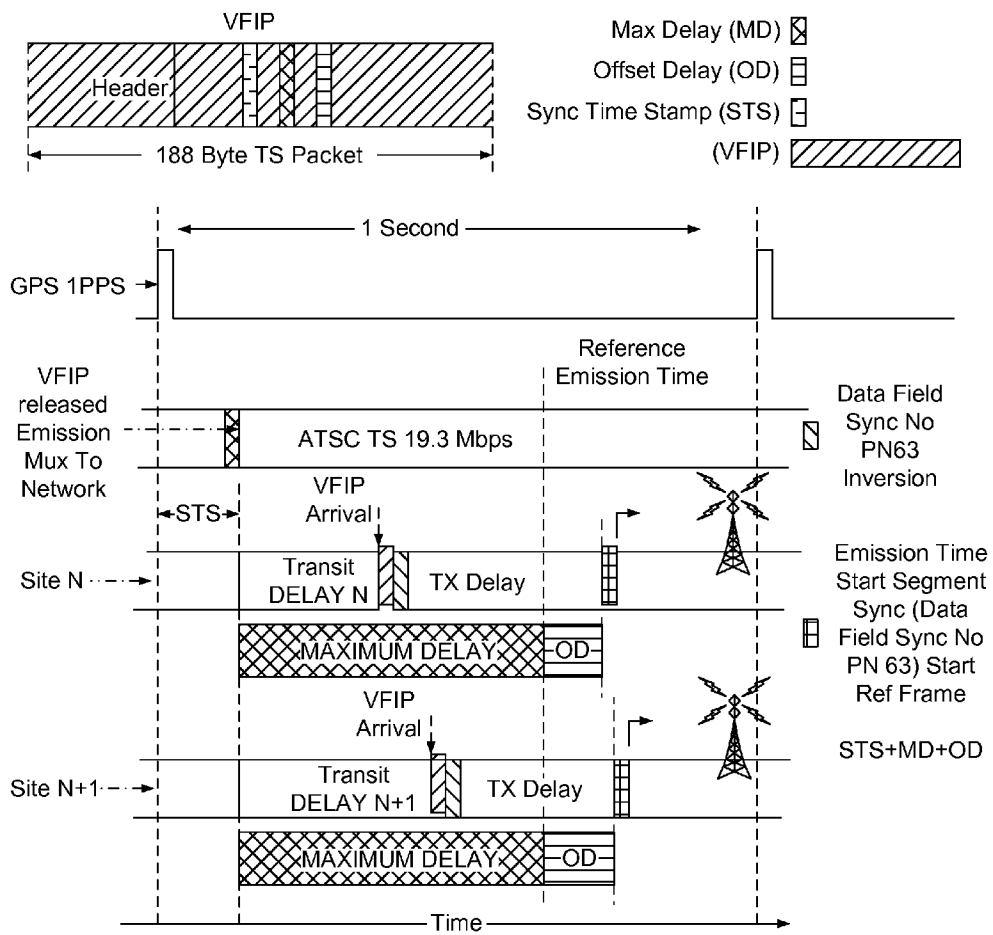

FIG. 11

Syntax	# bits	
VSF_Init_Packet(){		
Transport_packet_header	32	
periodic_flag	1	} Period Of VFIP
periodic_value	8	
sync_time_stamp	24	} Network Delay Compensation
maximum_delay	24	
network_ID	12	
For (i=0; i<20 i++) {		
tx_address	12	
tx_ID_level	3	
tx_Data_Inhibit	1	
tx_time_offset	16	} Individual Tx Delay
tx_power }	12	
Reserved stuff bytes DTR	96	
Reserved future use	xxx	
VFIP_FEC }	160	} 20 Bytes RS Parity

FIG. 12



APPARATUS, SYSTEMS AND METHODS FOR PRODUCING COHERENT SYMBOLS IN A SINGLE FREQUENCY NETWORK

CROSS REFERENCE TO RELATED APPLICATIONS

This application claims priority to, and the benefit of, U.S. Provisional Patent Application Ser. No. 60/657,416, filed Mar. 2, 2005, and U.S. Provisional Application Ser. No. 60/740,424, filed Nov. 29, 2005, both of which are hereby incorporated herein by reference in their entirety.

BACKGROUND OF THE INVENTION

1. Field of the Invention

The present invention generally relates to single frequency networks (SFNs) using a multiplicity of transmitters, and more particularly to technology for producing coherent symbols to implement SFNs.

2. Related Art

A single-frequency network (SFN) is a collection of transmitters operating on the same frequency for carrying the same information to receivers in a given area. The transmitters emit identical signals, several of which may be received more or less simultaneously by individual receivers. One advantage of using multiple transmitters instead of one powerful transmitter is that multiple transmitters provide alternate paths for the signal to enter a structure, such as a house, thereby providing better reception. In mountainous areas, for example, it may be difficult to find one location capable of serving all the population centers in the area, since they are often located in valleys. Multiple transmitters can be strategically placed to cover such small areas and fill in the gaps.

One application of SFNs is for transmission of digitally encoded data such as digital television (DTV), the system and related standards for which have been established by the Advanced Television Systems Committee ("ATSC"). Under the ATSC's DTV standard (or A/53 standard), hereby incorporated herein by reference in its entirety, it is possible to transmit large amounts of data including high definition pictures, high quality sound, multiple standard definition pictures, and other ancillary related or unrelated communications, which may be accessible by using a computer or television set.

The DTV standard includes the following layers: the video/audio layer, compression layer, transport layer, and the transmission layer. At the top of the hierarchy is the uncompressed digital signal in one of the various digital data formats (e.g., video/audio formats). The data stream that corresponds with the video/audio layer is known as the elementary stream.

The compression layer compresses the elementary stream into a bitstream with a lower data rate. In the ATSC DTV standard, MPEG-2 compression is used for the video and the Dolby AC-3 compression is used for the audio. The compressed bitstream, in turn, may be packetized and multiplexed with other bitstreams into a higher data rate digital bitstream in the transport layer by an multiplexer. The MPEG-2 transport protocol defines (among several other things) how to packetize and multiplex packets into an MPEG-2 transport stream. The result is a stream of highly compressed data packets in a multiplexed bitstream which may include multiple programs and/or multiple data signals.

The multiplexed bitstream from the transport layer is modulated onto a radio frequency ("RF") carrier in the transmission layer by a transmission system. The terrestrial broadcast mode utilized in the current ATSC DTV standard to

transmit digital signals over the airwaves is called eight-level Trellis Coded vestigial sideband (8T-VSB).

FIG. 1 is a block diagram of a well known Trellis-coded 8T-VSB transmitter **100** used in an RF transmission system. The transmitter receives the incoming data packets of interspersed video, audio, and ancillary data, and, using a data randomizer **102**, randomizes the data to produce a flat, noise-like spectrum. A Reed-Solomon (RS) encoder **104**, known for its good burst noise correction capability and data overhead efficiency, RS-encodes the randomized data to add parity bytes to the end of each data packet. In turn, the data is convolutionally interleaved (i.e., spread out) over many data segments by a byte data interleaver **106**.

A pre-coder and Trellis encoder **108** (referred to in the specification hereafter as a "Trellis coder") adds additional redundancy to the signal in the form of multiple data levels, creating multilevel data symbols for transmission. A synchronization insertion component **110** multiplexes the segment and frame synchronizations with the multilevel data symbols before a DC offset is added by a pilot insertion component **112** for creation of the low-level, in-phase pilot. Segment and frame synchronizations are not interleaved. A VSB modulator **114** provides a filtered intermediate frequency (IF) signal at a standard frequency, with most of one sideband removed. Finally, an RF upconverter **116** translates the signal to the desired RF channel.

Multipath propagation is a common problem in single transmitter broadcast environments because it places a burden on a receiver equalizer's ability to handle signal echoes. In a distributed transmission system, where multiple transmitters are utilized, the multipath propagation problem is compounded. It is necessary, therefore, to synchronize or adjust the timing of the SFN system to control the delay spread seen by receivers in areas of SFN induced multipath not to exceed delay handling range of receiver equalizers and become problematic.

In addition, the output symbols of each transmitter is based on the transport stream received, how this is then mapped into a Data Frame and the initial states of the Trellis coders, which are normally random. When the transmitters emit the same symbols as one another for the same data inputs, they are said to be made "coherent". If the transmitters in an SFN are not synchronized, they will not emit coherent symbols.

The ATSC has promulgated a standard, referred to as the A/110 standard, which provides rules for synchronization of multiple transmitters emitting Trellis-coded 8T-VSB signals in an SFN or distributed transmission system (DTx) to create a condition which allows multiple transmitters being fed by the same transport stream to produce coherent symbols. SFN and DTx are to be understood to be synonymous terms. The A/110 standard is hereby incorporated herein by reference in its entirety.

FIG. 2 shows a block diagram of an ATSC SFN system **200** using A/110 distributed transmission (DTx). SFN system **200** includes three elements: an external time and frequency reference (shown as GPS), a distributed transmission adapter (DTxA) **202** situated at the source end of the distribution (or studio-to-transmitter link (STL)) subsystem, and plural RF transmission systems **208**. DTxA includes two basic blocks: a transmitter synchronization inserter **206** and a data processing model **204**. Transmitter synchronization inserter **206** inserts information (described in more detail below) into the transport stream (TS). The data processing model **204** is a model of the data processing in an ATSC modulator which serves as a master reference to the slaved synchronized data processing blocks **210** in the RF transmission systems **208**. Generally, each RF transmission system **208** includes two

blocks: synchronized data processing block **210** and signal processing and power amplification block **211**, which collectively are sometimes referred to as a “modulator” **212**. These low level stages of the transmitter are also generally referred to as the “exciter” component. Herein the terms exciter and modulator are use interchangeably.

In an ATSC SFN system each synchronized data processing block **210** also includes a Trellis-coded 8-VSB transmitter **100** discussed above with reference to FIG. 1. As shown in FIG. 2, the DTxA produces a transport stream (TS) and feeds this stream to all of the synchronized data processing blocks **210**.

FIG. 3 shows the structure of a distributed transmission packet in accordance with the A/110 standard and FIG. 4 depicts a VSB data frame, which includes packets of data and forward error correction (FEC), and data field synchronization (DFS) fields.

The A/110 standard requires the following three ATSC system elements to be synchronized: 1. frequency synchronization of the pilot or carrier frequencies, 2. data frame synchronization, and 3. pre-coder and Trellis encoder (Trellis coder) synchronization. A description of how these three elements are synchronized in a group of separately located transmitters follows.

According to the A/110 standard, control of two specific transmitter frequencies is required. First the RF frequency of the transmitted signal, as measured by the frequency of its pilot, must be accurately controlled to maintain frequencies of the transmitters close enough to one another that the receiver is not over-burdened with apparent Doppler shift between the signals. The symbol clock frequency must be accurately controlled to allow the output symbol stream to maintain stable, relative, time offsets between transmitters in a network. A flag, stream_locked_flag, in the DTxP packet structure is used to identify one of two options for performing symbol frequency synchronization. This flag is a 1-bit field that indicates to a slave transmitter whether it is to lock its symbol clock frequency to the incoming transport stream clock frequency (normal ATSC methodology) or to lock its symbol clock frequency to the same external precision reference frequency used throughout the network (e.g., GPS).

Data frame synchronization requires all of the slave modulators **212** in an SFN to use the same transport stream (TS) packet to start a VSB data frame (FIG. 4). In the current ATSC A/110 standard, this is accomplished by using DTxA **202** by inserting a cadence signal. In particular, a cadence signal (CS) is inserted at a deterministic point in time, once every 624 packets, into the MPEG-2 transport stream from the DTxA to each of the modulators **212**. Dividing the rate of CS by half produces a Data Field Sync (DFS). The A/53 standard specifies that the data randomizer **102**, RS encoder **104**, and data interleaver **106** and intra-segment interleaver in part of **108** in the slave synchronized data processing blocks **210** shall all slave to DFS.

In addition, the A/110 standard provides that it is necessary to develop a state condition for the Trellis coder memories to be applied at a specific epoch in the data stream simultaneously by all RF transmission systems **208** in a network. According to the A/110 standard, “in order to put the precoders and trellis encoders of all the transmitters in a network in the same state at the same time, it is necessary to ‘jam sync’ them to the trellis coder model in the Distributed Transmission Adapter.” In other words, Trellis coders cannot be synchronized by identifying an epoch in the transport stream (TS). Instead, to place the Trellis coders of all the transmitters in a network in the same states at the same time, a sample of all Trellis coder states in the data processing model **204** is

captured, and this data is carried in an element of the DXP, Trellis_code_state (FIG. 3), from DTxA **202** to all the slave modulators **212**.

At a later, deterministic point in time, the Trellis code states that have been extracted from the DXP are used to initialize the memory of each Trellis coder in the slave modulators **212**, to the state of the data processing model **204** in DTxA **202**. Once this has been performed, the modulator Trellis coders are synchronized and all the modulators **212** should produce “coherent symbols.” In addition, the DTxA indicates operating mode to the transmitters and provides information to be transmitted in the data field sync data segment through a field rate side channel, which carries information updated regularly at a data field rate.

The method used by A/110 standard to achieve Trellis coder synchronization adds much complexity to the overall SFN distributed transmission system design by requiring the DTxA **202** to sample the data processing model’s Trellis coder states. Moreover, the A/110 does not provide the ability to post process data in the modulator once it exits the DTxA. A change of one bit in data stream after DTxA will break the Trellis code synchronization scheme thus making it difficult, if not impossible, to add enhancements to ATSC standard A/53. Moreover, as more transmitters are added in a multi-tier (e.g., distributed-translator) scheme the complexity of an SFN under the A/110 standard grows since an additional data processing model **204** must be added for each tier. Thus, what is needed is a technology that is scalable in SFN applications without adding additional complexity or constraints on system extensibility of the overall system.

Given the foregoing, what is needed is a system, method and computer program product for apparatus, systems and methods for producing coherent symbols in a single frequency network.

BRIEF DESCRIPTION OF THE INVENTION

The present invention meets the above-identified needs by providing apparatus, systems, and methods for producing coherent symbols in a single frequency network.

An advantage of the present invention is that it is backward compatible with existing ATSC standards and legacy ATSC receivers.

Another advantage of the present invention is that it provides a deterministic Trellis reset.

Yet another advantage of the present invention is that it provides deterministic VSB frame synchronization and can do so simultaneously with the deterministic Trellis reset in an efficient manner.

In one aspect of the present invention, systems, methods, apparatus and computer code are provided for producing a plurality of coherent symbols from a plurality of digital RF transmitters. A receiver receives a first initialization packet containing a plurality of stuff bytes and Trellis coders are deterministically initialized using the first initialization packet.

Further features and advantages of the present invention as well as the structure and operation of various embodiments of the present invention are described in detail below with reference to the accompanying drawings.

BRIEF DESCRIPTION OF THE DRAWINGS

The features and advantages of the present invention will become more apparent from the detailed description set forth

5

below when taken in conjunction with the drawings in which like reference numbers indicate identical or functionally similar elements.

FIG. 1 is a block diagram of a Trellis-coded 8-VSB transmitter **100**.

FIG. 2 shows a block diagram of an ATSC SFN system using A/110 distributed transmission where multiple Trellis coded 8T-VSB transmitters are fed by the same transport stream.

FIG. 3 shows the structure of distributed transmission packet in accordance with the A/110 standard.

FIG. 4 depicts a VSB data frame in accordance with the ATSC A/53 standard.

FIG. 5 is a system diagram of an exemplary SFN in accordance with an embodiment of the present invention.

FIG. 6 illustrates a method for inserting VSB frame initialization packets (VFIPs) in accordance with an embodiment of the present invention.

FIG. 7 depicts a structure of a VSB frame initialization packet (VFIP) in accordance with an embodiment of the present invention.

FIG. 8 is a block diagram of a data interleaver for interleaving a transport stream with VFIPs in accordance with an embodiment of the present invention.

FIG. 9 is a block diagram of an interleaver commutator feeding interleaved VFIPs to Trellis coders in accordance with an embodiment of the invention.

FIG. 10 depicts the output of an ATSC **52** segment continuous convolutional byte interleaver with an interleaved VFIP in accordance with an embodiment of the present invention.

FIG. 11 shows the structure of a VFIP in accordance with an embodiment of the present invention.

FIG. 12 depicts SFN synchronization timelines showing the timing syntax and semantics for an ATSC SFN in accordance with an embodiment of the present invention.

DETAILED DESCRIPTION

The present invention is now described in more detail herein in terms of an exemplary system, method and apparatus for producing coherent symbols in a single frequency network. This is for convenience only and is not intended to limit the application of the present invention. In fact, after reading the following description, it will be apparent to one skilled in the relevant art(s) how to implement the following invention in alternative embodiments (e.g., multi-frequency networks).

Generally, the present invention performs the required ATSC synchronizations: 1. frequency synchronization of the pilot or carrier frequencies, 2. data frame synchronization, and 3. pre-coder/trellis coder synchronization.

Frequency synchronization of the pilot or carrier is achieved by locking the carrier frequency of an exciter in the RF transmitter system to a reference from a GPS timebase.

The start of a data frame is determined (i.e., synchronized) by identifying a point in the transport stream via a special timing packet. Generally, a transport stream (TS) having a specialized timing packet is generated at a broadcast installation. The TS rate is locked to a GPS clock (e.g., 10 MHz), and the GPS temporal reference (e.g., one pulse per second (1PPS)) is used to construct the timing packet. The synchronization packets identify a cadence "epoch" point in the TS, which is used to slave all the data frames to be broadcast from one or more RF transmission systems, and hence provide data frame synchronization (DFS).

6

The present invention further provides a deterministic initialization of the Trellis coder memories by creating packets with predetermined data patterns located at deterministic positions throughout a data frame. The predetermined data patterns are transmitted from the broadcast station to an exciter to cause its Trellis coder states to be initialized in a fixed predictable fashion. Data frame synchronization and Trellis coder synchronization can thus occur using a single initialization packet.

FIG. 5 is a system diagram of an SFN **500** in accordance with an embodiment of the present invention. A transport stream emitter **514** in a broadcast installation such as a studio or network operations center ("NOC") is fed a data stream (e.g. MPEG-2 data stream). Transport stream emitter **514** transmits the data stream to a distribution network **506** in the form of a transport stream (TS) having VSB frame initialization packets (VFIPs). VFIPs are specialized synchronization packets generated by an emission multiplexer **504** of the transport stream emitter **514**. In one embodiment, a VFIP module within an emission multiplexer **504** generates VFIPs. The TS with a VFIP is transmitted to one or more transmission systems **502** through a distribution network **506** (e.g., fiber, satellite, microwave and the like). Emission multiplexer **504** is clocked by a GPS timebase **505**.

Another transport stream emitter configuration may be used instead of transport stream emitter **514**. Transport stream emitter **508**, for example, provides broadcast installations with the ability to use a standard multiplexer **510** with a VFIP inserter unit **509**. In this alternative transport stream emitter configuration, transport stream emitter **508** includes an external VFIP inserter unit **509** communicatively coupled to a standard multiplexer **510**. A transport stream (TS) with VFIP packets is similarly communicated from transport stream emitter **508** to RF transmission systems **502** through distribution network **506**.

RF transmission systems **502** down stream from the broadcast installation include an exciter **512** which can detect the VFIPs in the transport stream. In addition, RF transmission systems **502** include other components such as power amplifiers (PAs) **513**. As noted above exciters are also sometimes referred to as modulators.

In one embodiment of the present invention, emission multiplexer **504** as well as all the other nodes in SFN **500** are clocked by a common timebase, GPS timebase **505**. Frequency synchronization of the pilot or carrier is thus achieved by locking the carrier frequency of exciter **512** to the 10 MHz reference from the GPS timebase **505** to regulate the apparent Doppler shift seen by ATSC receiver from the SFN in overlapping coverage areas.

The following description of data frame synchronization and Trellis coder synchronization is applicable to both transport stream emitter configurations (**514** and **508**). For convenience, the following description is in terms of emission multiplexer **504**. In the foregoing discussion when appropriate corresponding components of transport stream emitter **508** are identified.

As explained above, data frame synchronization requires that all exciters in an SFN choose the same packet from the incoming TS to begin a VSB data frame. In the present invention, each exciter **512** follows the frame synchronization timing of emission multiplexer **504** to achieve initial frame synchronization and to maintain this condition.

Emission multiplexer **504**, has its data rate locked to the GPS reference **505**, and initiates frame synchronization by selecting one of the TS packets to begin a VSB Frame. Once an initial TS packet has been selected to start the count, emission multiplexer **504** counts 623 TS packets inclusive of

the selected packet (e.g., 0-622) emission multiplexer **504** inserts a VFIP as the last (623) packet. This corresponds to a container of data (624 packets) which is equivalent to the payload in an ATSC A/53 VSB frame having 624 payload segments.

Emission multiplexer **504** inserts a VSB frame initialization packet (VFIP), as shown in FIG. 6. By the placement of VFIP in the last packet slot (623) signaling of VSB frame is made implicit. Upon reception of the VFIP, each exciter **512** is signaled to the start a new data frame after the last bit of VFIP packet is received. The cadence also referred to as timing or frame rate of the VSB frames is thus based on the frame synchronization timing which is maintained by emission multiplexer **504**. Since emission multiplexer **504** is locked to GPS timebase **505**, the 0-623 packet count becomes the cadence of the VSB frame rate. After the first VFIP insertion, additional VFIPs can be inserted subsequently thereafter at a predetermined periodicity (e.g., approximately once per second). For example, whenever emission multiplexer **504** inserts a VFIP, it will appear in the 623 slot as determined by a cadence counter in emission multiplexer. As described in more detail below, additional timing parameters can be adjusted based on values of particular fields in the VFIP.

FIG. 7 depicts the structure of a VFIP in accordance with one embodiment of the present invention. As shown in FIG. 7, VFIP includes a packet identifier (PID) field stored in the header portion of the VFIP packet. Exciter **512** identifies a VFIP packet by its PID. In an exemplary embodiment, exciter **512** identifies a packet as a VFIP packet when its PID value is 0x1FFA. After the VFIP packet has been read, exciter **512** inserts a VSB data field sync (DFS). The frame payload segments thus begins after Data Field Sync #1. Exciter **512** in turn makes a determination whether 312 TS packets have been received. If so, exciter **512** inserts additional DFSs per the A/53 standard.

As described in the ATSC A/53 standard, a DFS includes a series of pseudorandom number (PN) sequences of length 511, 63, 63, and 63 symbols, respectively. The PN63 sequences are identical, except that the middle sequence is of opposite sign in every other field sync. This inversion allows the receiver to recognize the alternate data fields comprising a frame. In Data Field Sync #1 all three PN63 sequences are in the same phase and in Data Field Sync #2 the middle PN63 sequence is inverted and the other two have the same phase. The exciter **512** inserts a DFS with no PN63 inversion directly after the last bit of the VFIP packet and then continues with normal VSB frame construction starting with next TS packet (0) as first data-segment of the next VSB frame.

If an exciter **512** has already been frame synchronized, a received VFIP packet can be used to verify the exciter is still in phase with frame cadence maintained in emission multiplexer because of the implicit placement of VFIP in transport stream.

As explained above, it is also necessary to develop a state condition for the Trellis coder memories to be applied at a specific epoch in the data stream simultaneously by all transmitters in a network. The present invention uses a deterministic Trellis reset (DTR) to perform Trellis coder synchronization by forcing the Trellis coder to go into a known zero state as a pre-determined byte in the VFIP packet enters the Trellis coder.

Trellis coder synchronization is accomplished based on a priori knowledge of the location of the interleaved VFIP packet at the output of byte data interleaver **106** (FIG. 1) before the Trellis coder stage **108** (FIG. 1). With the knowledge of the output of the ATSC interleaver **106** once the data frame synchronization data has been achieved, twelve pre-

terminated byte positions in VFIP are identified and used to trigger a DTR in each of the twelve Trellis coders in all of the exciters in the SFN. The initialization occurs as soon as each of these deterministically assigned bytes first enter its designated Trellis coder. More particularly, all Trellis coders are synchronized after the first four (4) segments of the VSB Data Frame without any need for any syntax in VFIP itself. Additional syntax, described in more detail below, can be added to control the emission timing and other auxiliary transmitter functions. Thus, by using emission multiplexer **504** (or standard multiplexer **510** and VFIP inserter **509**) to insert a VFIP, VSB frame synchronization is implicitly signaled. By the time the fourth data segment of a new VSB frame is transmitted, all Trellis coders in all exciters will be deterministically reset to a common zero state. Coherent symbols will be produced by all transmitters in SFN.

FIG. 8 is a more detailed block diagram of an ATSC **52** segment continuous convolutional data interleaver. As shown, the interleaver is illustrated as shift registers which permute the symbols in the input signal, where the shift registers (except for the first one) cause a delay. FIG. 9 depicts how the interleaved data is fed to the Trellis coders (#0 through #11). The A/53 defines a deterministic starting point at the beginning of the first data segment of each data field. Based on this starting point and the beforehand knowledge of how byte data interleaver **106** will process a data stream, stuff bytes in a VFIP are pre-calculated and inserted in the correct byte positions to feed a respective one of the twelve Trellis coders. As each designated stuff byte enters a target Trellis coder, the DTR will be triggered.

FIG. 10 shows a memory map of the ATSC **52** segment continuous convolution data interleaver. As illustrated in FIG. 8, bytes are clocked in as illustrated by the commutator on left (i.e., from the Reed-Solomon encoder **104** output), and bytes are clocked out as illustrated by the commutator on the right from left to right (i.e., from the byte data interleaver **106** memory) and sent to the following stages of twelve (12) Trellis coders. As explained above, a Data Field Sync (DFS) is inserted later by the sync insertion unit **110** in the process by exciter **512**. The DFS temporal position is shown in the mapping as a horizontal line across middle of diagram depicted in the mapping shown in FIG. 10 to aide in the understanding of the present invention. In particular, FIG. 10 shows the insertion of a DFS (with no PN63 inversion) in response to a VFIP in the last packet slot (i.e., the 623rd packet) of the previous data frame.

The diagonal arrows in FIG. 10 show the positions assumed by bytes of the VFIP in the interleaver. As shown, a temporal dispersion of packets across VSB frame boundaries exists. Three of the VFIP bytes (**51,103,153**) reside in the last 52 segment group before the end of the previous frame (Frame n). The remaining data (bytes) are in the first 52 segments of current (Frame n+1). The (4) bytes marked on each of the three diagonal sections (i.e., the VFIP bytes **52-55, 104-107, 156-159** or "stuff bytes") will be delivered deterministically to each of the (12) Trellis coders numbered **5, 2, B, 8; 9, 6, 3, C; 1, A, 7, 4** (hex), respectively, when they exit the interleaver memory. This allows a deterministic trellis reset (DTR) to occur using each of the designated stuff bytes. Thus, a DTR occurs on processing of stuff bytes in a VFIP, and without affecting or occurring on packets carrying content (Video, Audio, Data). The VFIP Bytes **52-55, 104-107, 156-159** also are shown in FIG. 7 and in FIG. 11 ("Reserved stuff bytes DTR").

By knowing with certainty which VFIP bytes in an interleaved VFIP will pass through the Trellis coders, the stuff bytes can be used to trigger a Trellis reset (DTR) in all of the

exciters in the SFN. More particularly, when each one of these (12) stuff bytes first enter its respective Trellis coders, it will cause the Trellis coder to initialize to a predetermined state. This will occur in a serial fashion over four (4) segments and effectively synchronizes all (12) Trellis coders in all exciters **512** in a deterministic fashion. Advantageously, the deterministic Trellis coder reset is thus implemented in exciter **512** such that it adheres to the normal Trellis coder trajectories of a four state Trellis coder. This permits well known switch combinational logic to be used to achieve a common state.

A parity error will occur on every VFIP by the action of the DTR on the twelve designated stuff bytes; this is accepted and will not affect packets carrying normal content. As described above, the twelve Trellis Encoders in each exciter **512** will be reset over the first four segments (0,1,2,3) of Frame N+1 using the stuff bytes. More particularly, each stuff byte used for DTR will cause a deterministic (1) byte error in the RS decoder when VFIP is received. The RS encoding in A/53 allows for correction of up to 10 byte errors per packet. The twelve stuff bytes when DTR is performed will exceed this correction range by two bytes and will generate packet error in RS Decoder. An ATSC receiver ignores a packet error on a VFIP because the VFIP is a reserved PID value defined for use as an operational and maintenance packet (i.e., no content is carried within a VFIP). In particular, ATSC receivers demultiplex based on the PID value and ignore reserved packets (e.g., PID=0x1FFA) known not to be of any use to it. ATSC receivers also will ignore a packet if a parity byte error flag has been set in the header of that packet by the RS decoder in an ATSC receiver.

Referring to FIG. 11, another field in the VFIP is a 20 Byte RS parity field, VFIP_FEC, this additional outer RS coding provides byte errors correction (e.g., 10 byte error corrections) to protect the VFIP from possible errors introduced during transmission. This protects against errors on the distribution network link to the transmitters, and also permits special automated test and measurement equipment in the field to recover the payload of VFIP for network test and monitoring purposes. It should be understood that any type of correction coding that can provide the ability to detect and correct errors may be used instead of RS encoding and still be within the scope of the invention. In addition, the error-correction coding can be performed in the emission multiplexer **504** or by the VFIP inserter **509**, depending on the transport stream emitter configuration used.

The remaining unused space in VFIP is used for syntax for the timing and control of the SFN. The VFIP period is controlled by a field in the VFIP called the periodic_value. Setting this flag to high causes the VFIP to be inserted on a periodic_value field periodic basis. In particular, a value in a periodic_value field indicates the number of frames between insertions of VFIP. For example, a value of 20 would indicate a VFIP packet will be inserted by emission multiplexer **504** every 20 data frames, i.e., approximately once per second. Instead of making the VFIP delay periodic, a VFIP can be inserted at any multiple of a data frame in step with cadence counter described above.

The distribution network **506** to the transmission system **502** inherently has a delay due to the type of distribution network, e.g., fiber, microwave, satellite and the like, and other connections, e.g., coax cables and the like. Timing syntax within the VFIP allows each RF transmitter **502** to calculate an overall delay to compensate for these delays and provide tight temporal control of the emission time of the coherent symbols from the antennas of all transmitters in a SFN and thus provides control over the delay spread seen by receiver.

FIG. 12 depicts SFN synchronization timelines showing the timing syntax and semantics for an ATSC SFN in accordance with an embodiment of the present invention. Referring to FIGS. 11 and 12, sync_time_stamp (STS) and max_delay (MD or Maximum Delay) fields in the VFIP are used to provide compensation to all of the transmitters in the SFN for the unequal or time varying delay in distribution network **506**. In addition, the tx_time_offset (OD) field is used to fine tune or adjust timing of a particular RF transmitter **502** in the SFN.

As described above, the transport stream emitter (**514** and **508**) and all the exciters **512** in the SFN (i.e., all nodes) use a GPS timebase **505** to receive a frequency 10 MHz and a temporal 1PPS reference. A 24 bit binary counter within the transport stream emitters keeps track of the reference clock based on the GPS timebase **505**. This 24 bit counter is also available at all exciters **512**. The 1PPS signal from the GPS timebase **505** is used to reset a 24 bit binary counter to zero on rising edge of 1PPS. The counter is clocked by a 10 MHz frequency reference and counts from 0-9999999 in one second, then resets to zero. Each clock tick and count advance is 100 nano seconds. This 24 bit binary counter technique is available in all nodes of the network and forms the basis for all time stamps used in the SFN.

The sync_time_stamp (STS) field in a VFIP is a 24 bit field containing the value the 24-bit counter will assume in emission multiplexer **504** observed at the instant VFIP leaves the emission multiplexer **504** to distribution network **506**. In the alternative configuration, the sync_time_stamp (STS) field in a VFIP is a 24 bit field containing the value the 24 bit binary counter will assume in the VFIP inserter **509** observed at the instant VFIP leaves the VFIP inserter **509** to distribution network **506**. Similar 24-bit counters are included in the RF transmitter systems **502**. All counters at all the nodes in the network are synchronized to the same GPS 10 MHz and 1PPS, allowing their counts to be synchronized. Each increment of the counter is 100 nano seconds. This known value is used in each RF transmitter **502** to calculate a transit delay (TD) through its respective distribution network (e.g., Satellite, Microwave, Fiber, and the like). More particularly, as described above, the STS value is the time that the VFIP left emission multiplexer **504** and entered distribution network **506**. The STS value is compared to an observation of the current count of the 24 bit counter in exciter **512** the instant the VFIP is received to determine the TD of how long (i.e., how many 100 nano second increments) the VFIP packet took to arrive through the distribution network **506**. FIG. 12 shows graphically the release of VFIP into distribution network **506** and the instant VFIP arrives at a transmitter **502** as a function of time.

The maximum_delay field in the VFIP (corresponding to Maximum Delay or MD in FIG. 12) is a 24-bit value containing a predetermined delay value established based on a quantitative review of the delays of all distribution paths to all digital RF transmitters in the SFN. Particularly, the maximum delay value entered is calculated to be greater than the delay of the longest path in distribution network **506**. By selecting an MD value larger than the maximum transit delay expected through all distribution paths, an input buffer can be calculated and setup in each exciter **512** to delay the incoming TS packets such that they are transmitted from all transmitters simultaneously regardless of the transit time of a packet through distribution network **506**. This is shown in FIG. 12 as the Reference Emission Time. The reference emission time is the start of segment sync in DFS (without PN63 inversion) immediately following VFIP.

11

The tx_time_offset (OD) field is a 16 bit value addressed to each transmitter that contains an optional delay value used to fine tune the delay spread of particular transmitters to optimize the network.

Thus, based on the calculation of how long the VFIP packet took to arrive using in part the synch_time_stamp (STS), the maximum_delay (MD) value and a tx_offset_delay (OD), an RF transmitter 502 can set its input delay buffer, TX Delay. Accordingly, the value of the delay buffer in each exciter 512, TX Delay, is shown in FIG. 12 and defined by Equation (1) as follows:

$$TX\ Delay = STS + MD + OD - TD \quad (1)$$

Thus, the TX delay for each exciter in the SFN 500 is independently calculated. Each RF transmitter 502, in turn, uses the delay global values (e.g., STS, MD) to establish the reference emission time. The individually addressed OD allows fine control of the emission time of the coherent symbols from all the antennas of all transmitters in a SFN and hence will control the delay spread seen by ATSC receiver. A local value (e.g., 16 bit value, not shown) also can be entered at each site to compensate for the delay calculated through the transmitters, output filters and transmission line length feeding the Antenna. This value is subtracted from MD for a particular transmitter to obtain fine resolution on emission time from the antenna which is the reference or demarcation point in an SFN system (i.e., the point at which the RF signal guided wave transitions into free space).

While various embodiments of the present invention have been described above, it should be understood that they have been presented by way of example, and not limitation. It will be apparent to persons skilled in the relevant art(s) that various changes in form and detail can be made therein without departing from the spirit and scope of the present invention. Thus, the present invention should not be limited by any of the above described exemplary embodiments, but should be defined only in accordance with the following claims and their equivalents.

In addition, it should be understood that the figures illustrated in the attachments, which highlight the functionality and advantages of the present invention, are presented for example purposes only. The architecture of the present invention is sufficiently flexible and configurable, such that it may be utilized in ways other than that shown in the accompanying figures.

Further, the purpose of the foregoing Abstract is to enable the U.S. Patent and Trademark Office and the public generally, and especially the scientists, engineers and practitioners in the art who are not familiar with patent or legal terms or phraseology, to determine quickly from a cursory inspection the nature and essence of the technical disclosure of the application. The Abstract is not intended to be limiting as to the scope of the present invention in any way. It is also to be understood that the steps and processes recited in the claims need not be performed in the order presented.

What is claimed is:

1. A method for producing a plurality of coherent symbols from a plurality of digital RF transmitters, each of the plurality of digital RF transmitters having a plurality of Trellis coders, the method comprising the steps of:

receiving a first initialization packet containing a plurality of stuff bytes, each stuff byte positioned in a predetermined byte position, respectively; and

setting each one of the plurality of Trellis coders to a predetermined state as a corresponding stuff byte enters, thereby causing the plurality of digital RF transmitters to transmit a plurality of symbols coherently.

12

2. The method according to claim 1, further comprising the step of:

receiving another initialization packet after a multiple of a predetermined number of packets.

3. The method of claim 1, wherein the initialization packet is received from a transport stream.

4. The method of claim 1, further comprising the step of: error-correction decoding the initialization packet.

5. The method of claim 1, wherein the initialization packet further contains a synchronization timestamp based from a common timebase, a predetermined maximum delay value, an offset delay value, and a transmitter address corresponding to the offset delay.

6. The method according to claim 5, wherein the common timebase is the global positional system (GPS).

7. The method according to claim 1, further comprising: interleaving the initialization packet.

8. The method of claim 1, further comprising the step of: locking a symbol clock and a carrier frequency to a common timebase.

9. The method of claim 8, further comprising the step of: locking a digital signal comprising the initialization packet to the common timebase.

10. The method according to claim 9, wherein the common timebase is the global positional system (GPS).

11. The method of claim 1, further comprising the step of: modulating a digital signal using at least one of an eight-level vestigial sideband (8-VSB) modulation and an eight-level Trellis vestigial sideband (8T-VSB) modulation.

12. The method of claim 1, further comprising the step of: synchronizing a plurality of data frames based on the arrival of the initialization packet.

13. The method of claim 1, further comprising the step of: slaving a plurality of data frames to be broadcasted from the plurality of digital RF transmitters based on reception of an initialization packet.

14. The method of claim 1, further comprising the step of: calculating a delay metric corresponding to a synchronization timestamp, a maximum delay value, and an offset delay value in the initialization packet, and a common timebase, wherein the synchronization timestamp is a value of the common timebase observed when the initialization packet is transmitted into a distribution network, wherein the maximum delay value corresponds to a delay in a distribution network, and the offset delay value corresponds to a delay value addressed to a respective one of the plurality of digital RF transmitters.

15. The method according to claim 14, wherein the common timebase is the global positional system (GPS).

16. The method of claim 1, further comprising the step of: delaying the digital signal from being transmitted by the plurality of RF transmitters by a predetermined delay.

17. The method of claim 16, wherein the predetermined delay is greater than the longest delay path in a distribution network to the plurality of digital RF transmitters.

18. A apparatus for producing a plurality of coherent symbols from a plurality of digital RF transmitters, comprising:

a packet receiver operable to receive a first initialization packet containing a plurality of stuff bytes, each stuff byte positioned in a predetermined byte position, respectively; and

a plurality of Trellis coders, each Trellis coder operable to set to a predetermined state as a corresponding stuff byte enters, thereby causing the plurality of digital RF transmitters to transmit a plurality of symbols coherently.

13

19. The apparatus according to claim 18, wherein the packet receiver is further operable to detect another initialization packet after a multiple of a predetermined number of packets.

20. The apparatus of claim 18, wherein the initialization packet is received from a transport stream.

21. The apparatus of claim 18, further comprising: a decoder operable to error-correction decode the initialization packet.

22. The apparatus of claim 18, wherein the initialization packet further contains a synchronization timestamp based from a common timebase, a predetermined maximum delay value, an offset delay value, and a transmitter address corresponding to the offset delay.

23. The apparatus according to claim 22, wherein the common timebase is the global positional system (GPS).

24. The apparatus according to claim 18, further comprising: an interleave operable to interleave the initialization packet.

25. The apparatus of claim 18, further comprising: a timing unit operable to lock a symbol clock and a carrier frequency to a common timebase.

26. The apparatus of claim 25, wherein the timing unit is further operable to lock a digital signal including the initialization packet to the common timebase.

27. The apparatus according to claim 26, wherein the common timebase is the global positional system (GPS).

28. The apparatus of claim 18, further comprising: a signal processor operable to modulate a digital signal carrying the initialization packet using at least one of an eight-level vestigial sideband (8-VSB) modulation and an eight-level Trellis vestigial sideband (8T-VSB) modulation.

29. The apparatus of claim 18, further comprising: a timing unit operable to synchronize a plurality of data frames based on the arrival of the initialization packet.

30. The apparatus of claim 18, further comprising: a controller operable to slave a plurality of data frames to be broadcasted from the plurality of digital RF transmitters based on reception of an initialization packet.

31. The apparatus of claim 18, further comprising: a timing unit operable to calculate a delay metric corresponding to a synchronization timestamp, a maximum delay value, and an offset delay value in the initialization packet, and a common timebase, wherein the synchronization timestamp is a value of the common timebase observed when the initialization packet is transmitted into a distribution network, wherein the maximum delay value corresponds to a delay in a distribution network, and the offset delay value corresponds to a delay value addressed to a respective one of the plurality of digital RF transmitters.

32. The apparatus according to claim 31, wherein the common timebase is the global positional system (GPS).

33. The apparatus of claim 18, further comprising: a timing unit operable to delay the digital signal from being transmitted by the plurality of RF transmitters by a predetermined delay.

34. The apparatus of claim 33, wherein the predetermined delay is greater than the longest delay path in a distribution network to the plurality of digital RF transmitters.

35. A computer-readable medium having stored thereon sequences of instructions, the sequences of instructions including instructions which when executed by a computer system causes the computer system to:

14

receive a first initialization packet containing a plurality of stuff bytes, each stuff byte positioned in a predetermined byte position, respectively; and

set each one of the plurality of Trellis coders to a predetermined state as a corresponding stuff byte enters, thereby causing the plurality of digital RF transmitters to transmit a plurality of symbols coherently.

36. The computer-readable medium of claim 35, further including instructions which when executed by a computer system causes the computer system to:

receive another initialization packet after a multiple of a predetermined number of packets.

37. The computer-readable medium of claim 35, wherein the initialization packet is received from a transport stream.

38. The computer-readable medium of claim 35, further including instructions which when executed by a computer system causes the computer system to:

error-correction decode the initialization packet.

39. The computer-readable medium of claim 35, wherein the initialization packet further contains a synchronization timestamp based from a common timebase, a predetermined maximum delay value, an offset delay value, and a transmitter address corresponding to the offset delay.

40. The computer-readable medium of claim 39, wherein the common timebase is the global positional system (GPS).

41. The computer-readable medium of claim 35, further including instructions which when executed by a computer system causes the computer system to:

interleave the initialization packet.

42. The computer-readable medium of claim 35, further including instructions which when executed by a computer system causes the computer system to:

lock a symbol clock and a carrier frequency to a common timebase.

43. The computer-readable medium of claim 42, further including instructions which when executed by a computer system causes the computer system to:

lock a digital signal comprising the initialization packet to the common timebase.

44. The computer-readable medium of claim 43, wherein the common timebase is the global positional system (GPS).

45. The computer-readable medium of claim 35, further including instructions which when executed by a computer system causes the computer system to:

modulate a digital signal carrying the initialization packet using at least one of an eight-level vestigial sideband (8-VSB) modulation and an eight-level Trellis vestigial sideband (8T-VSB) modulation.

46. The computer-readable medium of claim 35, further including instructions which when executed by a computer system causes the computer system to:

synchronize a plurality of data frames based on the arrival of the initialization packet.

47. The computer-readable medium of claim 35, further including instructions which when executed by a computer system causes the computer system to:

slave a plurality of data frames to be broadcasted from the plurality of digital RF transmitters based on reception of an initialization packet.

48. The computer-readable medium of claim 35, further including instructions which when executed by a computer system causes the computer system to:

calculate a delay metric corresponding to a synchronization timestamp, a maximum delay value, and an offset delay value in the initialization packet, and a common timebase, wherein the synchronization timestamp is a value of the common timebase observed when the ini-

15

tialization packet is transmitted into a distribution network, wherein the maximum delay value corresponds to a delay in a distribution network, and the offset delay value corresponds to a delay value addressed to a respective one of the plurality of digital RF transmitters.

49. The computer-readable medium of claim 48, wherein the common timebase is the global positional system (GPS).

50. The computer-readable medium of claim 35, further including instructions which when executed by a computer system causes the computer system to:

computer readable program code means for causing the computer to delay the digital signal from being transmitted by the plurality of RF transmitters by a predetermined delay.

51. The computer-readable medium of claim 50, wherein the predetermined delay is greater than the longest delay path in a distribution network to the plurality of digital RF transmitters.

52. An apparatus for producing a plurality of coherent symbols from a plurality of digital RF transmitters, each of the plurality of digital RF transmitters having a plurality of Trellis coders, comprising:

means for receiving a first initialization packet containing a plurality of stuff bytes, each stuff byte positioned in a predetermined byte position, respectively; and

means for setting each one of the plurality of Trellis coders to a predetermined state as a corresponding stuff byte enters, thereby causing the plurality of digital RF transmitters to transmit a plurality of symbols coherently.

53. The apparatus according to claim 52, further comprising:

means for receiving another initialization packet after a multiple of a predetermined number of packets.

54. The apparatus of claim 52, wherein the initialization packet is received from a transport stream.

55. The apparatus of claim 52, further comprising:

means for error-correction decoding the initialization packet.

56. The apparatus of claim 52, wherein the initialization packet further contains a synchronization timestamp based from a common timebase, a predetermined maximum delay value, an offset delay value, and a transmitter address corresponding to the offset delay.

57. The apparatus according to claim 56, wherein the common timebase is the global positional system (GPS).

58. The apparatus according to claim 52, further comprising:

means for interleaving the initialization packet.

59. The apparatus of claim 52, further comprising:

means for locking a symbol clock and a carrier frequency to a common timebase.

60. The apparatus of claim 59, further comprising:

means for locking a digital signal comprising the initialization packet to the common timebase.

61. The apparatus according to claim 60, wherein the common timebase is the global positional system (GPS).

62. The apparatus of claim 52, further comprising:

means for modulating a digital signal using at least one of an eight-level vestigial sideband (8-VSB) modulation and an eight-level Trellis vestigial sideband (8T-VSB) modulation.

63. The apparatus of claim 52, further comprising:

means for synchronizing a plurality of data frames based on the arrival of the initialization packet.

16

64. The apparatus of claim 52, further comprising:

means for slaving a plurality of data frames to be broadcasted from the plurality of digital RF transmitters based on reception of an initialization packet.

65. The apparatus of claim 52, further comprising:

means for calculating a delay metric corresponding to a synchronization timestamp, a maximum delay value, and an offset delay value in the initialization packet, and a common timebase, wherein the synchronization timestamp is a value of the common timebase observed when the initialization packet is transmitted into a distribution network, wherein the maximum delay value corresponds to a delay in a distribution network, and the offset delay value corresponds to a delay value addressed to a respective one of the plurality of digital RF transmitters.

66. The apparatus according to claim 65, wherein the common timebase is the global positional system (GPS).

67. The apparatus of claim 52, further comprising:

means for delaying the digital signal from being transmitted by the plurality of RF transmitters by a predetermined delay.

68. The apparatus of claim 67, wherein the predetermined delay is greater than the longest delay path in a distribution network to the plurality of digital RF transmitters.

69. A system for producing a plurality of coherent symbols from a plurality of digital RF transmitters, comprising:

a multiplexer operable to receive a digital signal containing content data to be broadcast from the plurality of digital RF transmitters and to insert a first initialization packet into the digital signal, the first initialization packet containing a plurality of stuff bytes, each stuff byte positioned in a predetermined byte position, respectively, and to transmit the digital signal to the plurality of digital RF transmitters; and

a modulator having a plurality of Trellis coders, the modulator operable to receive the digital signal, extract the first initialization packet and to set each one of the plurality of Trellis coders to a predetermined state as a corresponding stuff byte enters, thereby causing the plurality of digital RF transmitters to transmit a plurality of symbols coherently.

70. The system of claim 69, wherein the multiplexer is further operable to generate another initialization packet after a multiple of a predetermined number of packets.

71. The system of claim 69, wherein the multiplexer transmits the digital signal to the modulator in over a distribution network.

72. The system of claim 69, the multiplexer further comprising an encoder operable to error-correction encode the initialization packet and the modulator further comprising a decoder operable to error-correction decode the initialization packet.

73. The system of claim 69, wherein the initialization packet further contains a synchronization timestamp based from a common timebase, a predetermined maximum delay value, an offset delay value, and a transmitter address corresponding to the offset delay.

74. The system according to claim 73, wherein the common timebase is the global positional system (GPS).

75. The system according to claim 69, the modulator further comprising:

an interleave operable to interleave the initialization packet

76. The system of claim 69, further comprising:

a timing unit operable to lock a symbol clock and a carrier frequency to a common timebase.

17

77. The system of claim 76, wherein the timing unit is further operable to lock a digital signal including the initialization packet to the common timebase.

78. The system according to claim 77, wherein the common timebase is the global positional system (GPS).

79. The system of claim 69, wherein the modulator is further operable to modulate a digital signal carrying the initialization packet using at least one of an eight-level vestigial sideband (8-VSB) modulation and an eight-level Trellis vestigial sideband (8T-VSB) modulation.

80. The system of claim 69, the modulator further comprising:

a timing unit operable to synchronize a plurality of data frames based on the arrival of the initialization packet.

81. The system of claim 69, the modulator further comprising:

a controller operable to slave a plurality of data frames to be broadcasted from the plurality of digital RF transmitters based on reception of an initialization packet.

18

82. The system of claim 69, further comprising: a timing unit operable to calculate a delay metric corresponding to a synchronization timestamp, a maximum delay value, and an offset delay value in the initialization packet, and a common timebase, wherein the synchronization timestamp is a value of the common timebase observed when the initialization packet is transmitted into a distribution network, wherein the maximum delay value corresponds to a delay in a distribution network, and the offset delay value corresponds to a delay value addressed to a respective one of the plurality of digital RF transmitters.

83. The system according to claim 82, wherein the common timebase is the global positional system (GPS).

84. The system of claim 69, further comprising: a timing unit operable to delay the digital signal from being transmitted by the plurality of RF transmitters by a predetermined delay.

85. The system of claim 84, wherein the predetermined delay is greater than the longest delay path in a distribution network to the plurality of digital RF transmitters.

* * * * *

UNITED STATES PATENT AND TRADEMARK OFFICE
CERTIFICATE OF CORRECTION

PATENT NO. : 7,532,677 B2
APPLICATION NO. : 11/276453
DATED : May 12, 2009
INVENTOR(S) : Michael Simon

Page 1 of 2

It is certified that error appears in the above-identified patent and that said Letters Patent is hereby corrected as shown below:

COLUMN 1

Line 58, "an" should read --a--.

COLUMN 4

Line 2, "DTXA" should read --DTxA--.
Line 18, "DTXA 202" should read --DTxA 202--.

COLUMN 6

Line 36, "down stream" should read --downstream--.

COLUMN 8

Line 42, "aide" should read --aid--.

COLUMN 10

Line 56, "maximum" should read --maximum_delay--.
Line 57, "delay" should be deleted.

COLUMN 11

Line 23, "Antenna." should read --antenna.--.

COLUMN 12

Line 57, "A" should read --An--.

COLUMN 13

Line 19, "interleave" should read --interleaver--.

COLUMN 15

Line 11-12, "computer readable program code means for causing the computer to"
should be deleted.

COLUMN 16

Line 47, "in" should be deleted.

Line 63, "interleave" should read --interleaver--. (1st occurrence)

Signed and Sealed this

Twenty-third Day of February, 2010

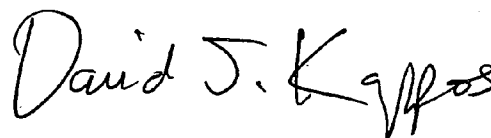
A handwritten signature in black ink that reads "David J. Kappos". The signature is written in a cursive style with a large initial "D" and "K".

David J. Kappos
Director of the United States Patent and Trademark Office