



US005947546A

United States Patent [19]
Hilliard et al.

[11] **Patent Number:** **5,947,546**
[45] **Date of Patent:** **Sep. 7, 1999**

- [54] **APPARATUS FOR ATTACHING A SOFT TOP TO A MOTOR VEHICLE**
- [75] Inventors: **Michael E. Hilliard**, Plymouth; **Kipp D. Owen**, Franklin; **Mark G. Vervaeke**, Sterling Heights; **John F. Miller**, Lambertville, all of Mich.; **John C. Wainwright**, Loudon, Tenn.; **Robert L. Hart**, Golden; **Nancy L. Brunner**, Broomfield, both of Colo.

3,090,646	5/1963	Johnson	296/107.11
3,285,259	11/1966	Hale	135/6
3,307,566	3/1967	Hale	135/6
3,367,349	2/1968	O'Link	135/6
3,371,672	3/1968	Hale et al.	135/6
3,536,354	10/1970	Ingram	296/147
3,773,379	11/1973	Loiseau	296/107
3,994,524	11/1976	Lehmann	296/107

(List continued on next page.)

FOREIGN PATENT DOCUMENTS

- [73] Assignees: **Chrysler Corporation**, Auburn Hills, Mich.; **Bestop, Inc.**, Broomfield, Colo.
- [21] Appl. No.: **08/955,959**
- [22] Filed: **Oct. 22, 1997**

0 146 884	12/1984	European Pat. Off.	.
129392	7/1932	Germany	.
1152899	8/1963	Germany	.
3127525	1/1983	Germany	.
004114823 A1	11/1992	Germany	.

(List continued on next page.)

Related U.S. Application Data

- [60] Provisional application No. 60/029,154, Oct. 22, 1996, provisional application No. 60/028,994, Oct. 23, 1996, provisional application No. 60/028,995, Oct. 23, 1996, provisional application No. 60/028,996, Oct. 23, 1996, provisional application No. 60/028,997, Oct. 23, 1996, provisional application No. 60/028,998, Oct. 23, 1996, provisional application No. 60/028,999, Oct. 23, 1996, and provisional application No. 60/029,737, Nov. 23, 1996.

- [51] **Int. Cl.⁶** **B60J 7/00**
- [52] **U.S. Cl.** **296/107.11; 296/107.12; 296/121; 296/102**
- [58] **Field of Search** **296/121, 107.11, 296/107.12, 102; 160/395, 403; 135/119, 907**

References Cited

U.S. PATENT DOCUMENTS

974,072	10/1910	Kenyon	.
1,741,318	12/1929	Kroh	.
1,808,298	6/1931	Du Pont	.
2,580,337	12/1951	Votyпка	296/107
2,682,427	6/1954	Bright	296/44
2,697,633	12/1954	Slason	296/116
2,817,345	12/1957	Woodruff, Sr.	135/6
2,823,684	2/1958	Sartori	135/6
2,864,388	12/1958	Oliver	135/1
2,893,782	7/1959	Pollock	296/107.11

OTHER PUBLICATIONS

Robert C. Ackerson, Standart Catalog of 4x4's 1945-1993, pp. 385-415, no date.

Primary Examiner—Joseph D. Pape
Assistant Examiner—Kiran Patel
Attorney, Agent, or Firm—William J. Coughlin

[57] **ABSTRACT**

An apparatus for attaching a soft top to a motor vehicle includes a retainer member for engaging a channel located in a structural element attached to the motor vehicle. In one application, the structural element is a removable door frame having a molded-in channel which opens downwardly and is disposed above a door opening. The retainer member includes a first flange adapted to fixedly attach to a lateral edge of the top section of the soft top. The retainer member further includes a second flange for engaging the molded-in channel in an interference fit. The first flange laterally extends beyond the door of the vehicle to thereby shingle the door from condensation and rain which may gather on the soft top. In an alternative embodiment, the retainer member is configured to form a trough for carrying the condensation and rain rearward away from the door.

17 Claims, 14 Drawing Sheets

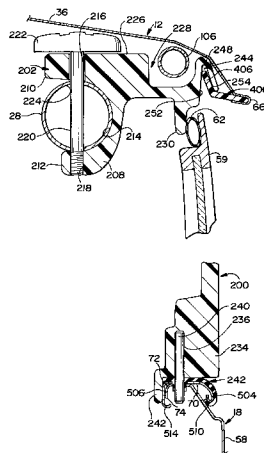

U.S. PATENT DOCUMENTS

4,066,292	1/1978	Carli	296/137	5,066,063	11/1991	Mullally	296/100
4,260,188	4/1981	Bauer	296/107	5,072,987	12/1991	Allen	296/107
4,310,194	1/1982	Biller	296/159	5,238,288	8/1993	Chandler	296/100
4,402,544	9/1983	Artim et al.	296/110	5,267,771	12/1993	Rothe	296/107.12
4,440,436	4/1984	Giddens et al.	296/107	5,299,850	4/1994	Kaneko et al.	296/107
4,593,641	6/1986	Adams et al.	114/343	5,303,667	4/1994	Zirkelbach et al.	114/361
4,639,034	1/1987	Amos	296/100	5,385,377	1/1995	Girard	296/36
4,729,593	3/1988	Nisiguchi et al.	296/154	5,531,497	7/1996	Cheng	296/100
4,789,196	12/1988	Fields	296/100	5,540,476	7/1996	Cowsert	296/107.11
4,828,317	5/1989	Muscat	296/122	5,544,934	8/1996	Murkett et al.	296/102
4,850,634	7/1989	Taubitz	296/107	5,556,156	9/1996	Kirk	296/100
4,898,420	2/1990	Takada	296/219	5,673,959	10/1997	Padlo	296/116
4,915,440	4/1990	Daniel et al.	296/104	5,765,903	6/1998	Essig et al.	296/102
4,927,202	5/1990	Wagner	296/107	FOREIGN PATENT DOCUMENTS			
4,930,835	6/1990	Brice et al.	296/102	0192631	8/1988	Japan .	
4,962,960	10/1990	Wurl et al.	296/121	0164623	6/1989	Japan .	
4,964,669	10/1990	Geier	296/108	0204129	8/1990	Japan .	
5,004,291	4/1991	Bauer et al.	296/116	406106986	4/1994	Japan .	
5,005,896	4/1991	Li	296/100	406106989	4/1994	Japan .	
5,033,787	7/1991	Takada	296/102	406106990	4/1994	Japan .	
5,042,868	8/1991	Nothaft et al.	296/107	0652977	12/1985	Switzerland .	
5,058,943	10/1991	Louderback	296/107	486283	6/1938	United Kingdom .	

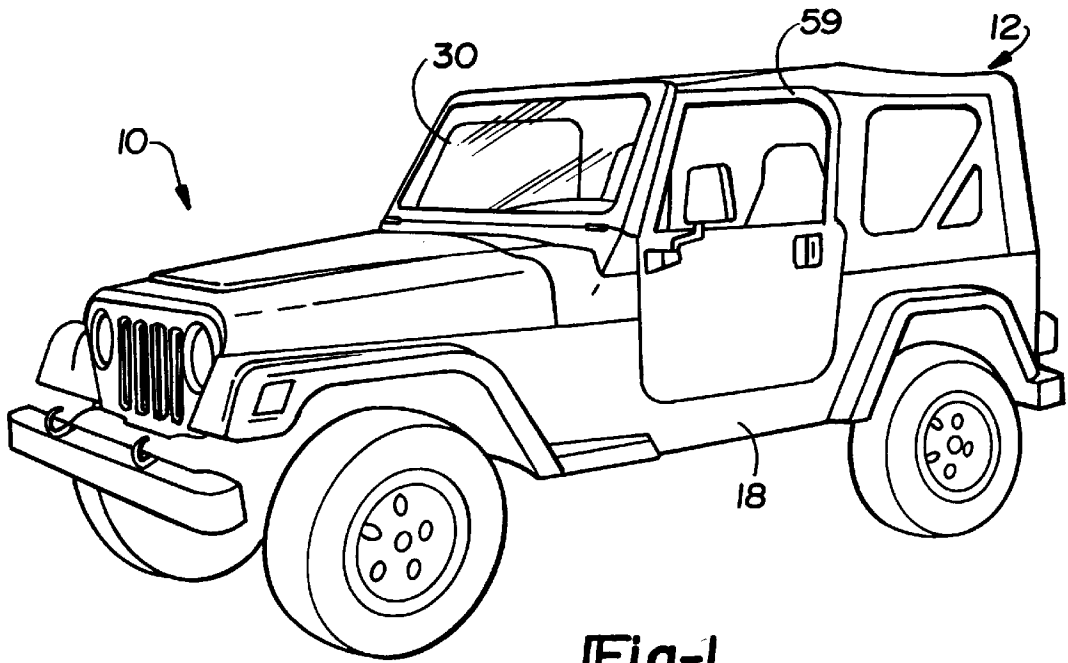

Fig-1

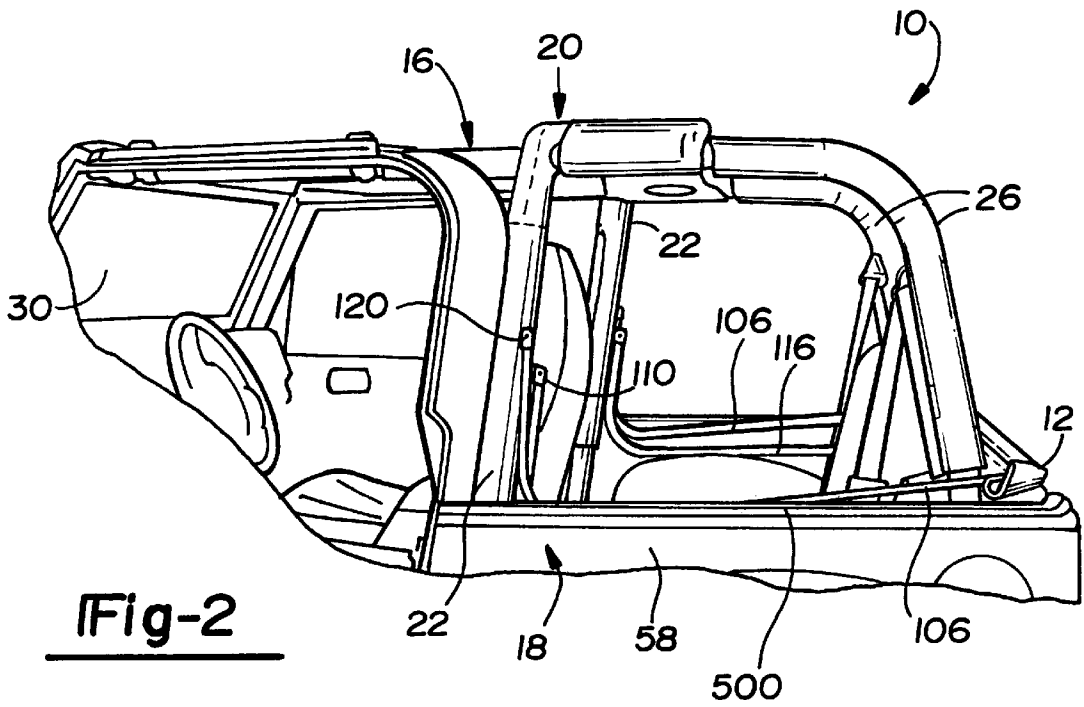

Fig-2

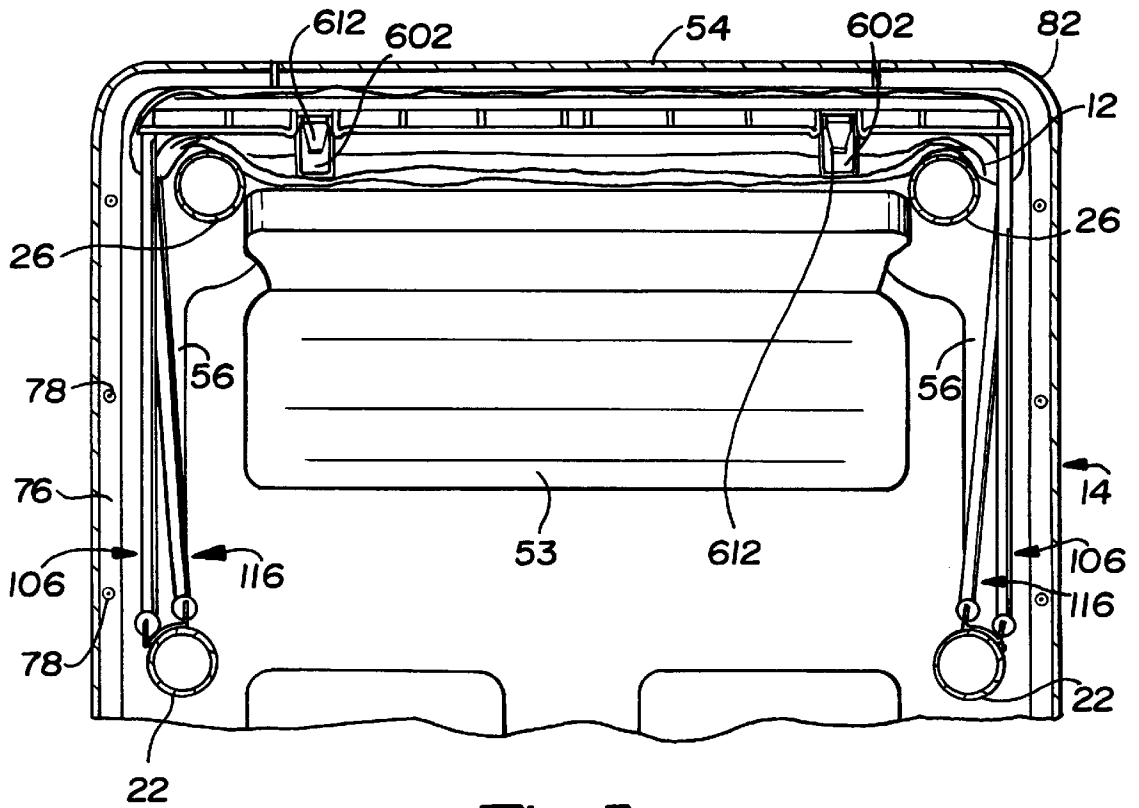

Fig-5

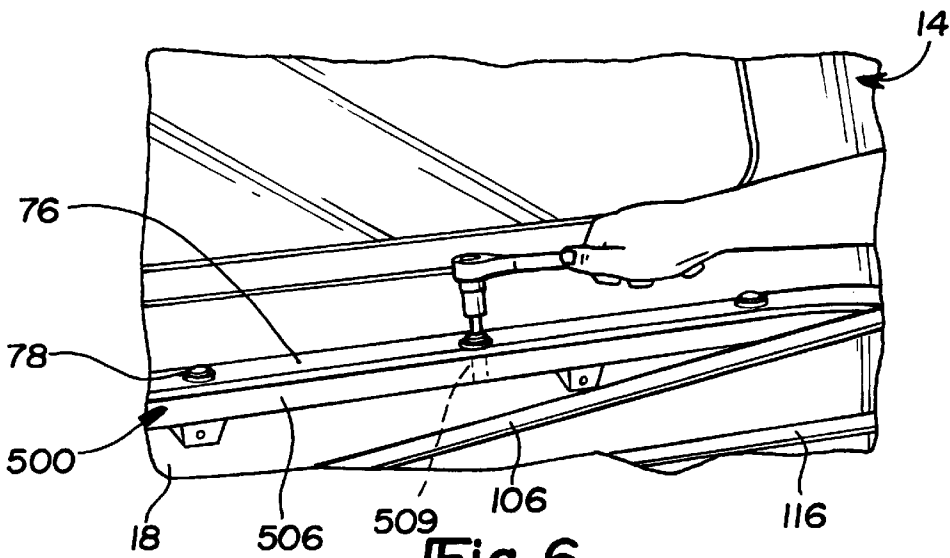
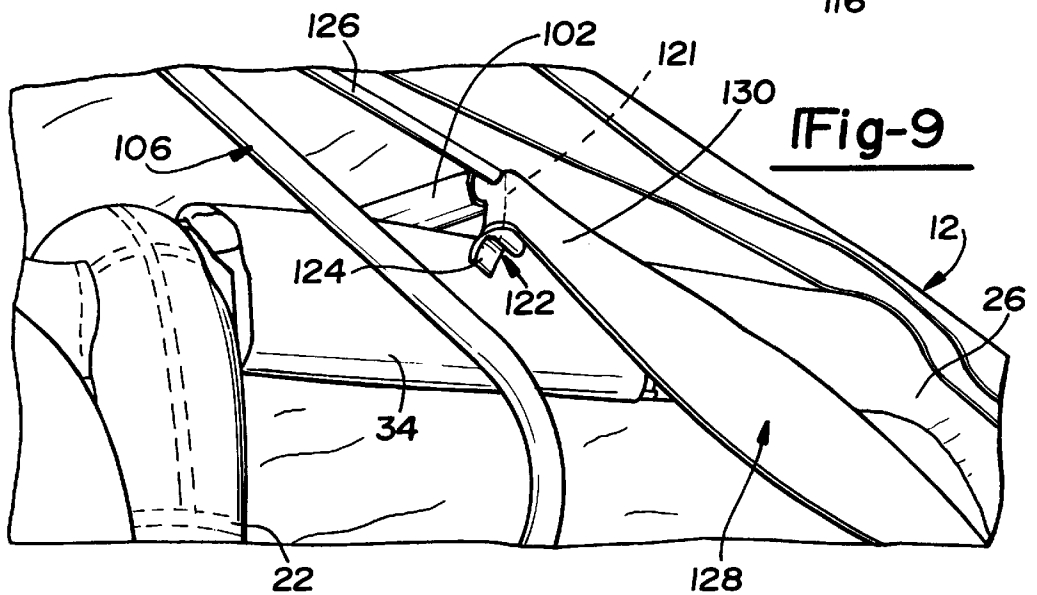
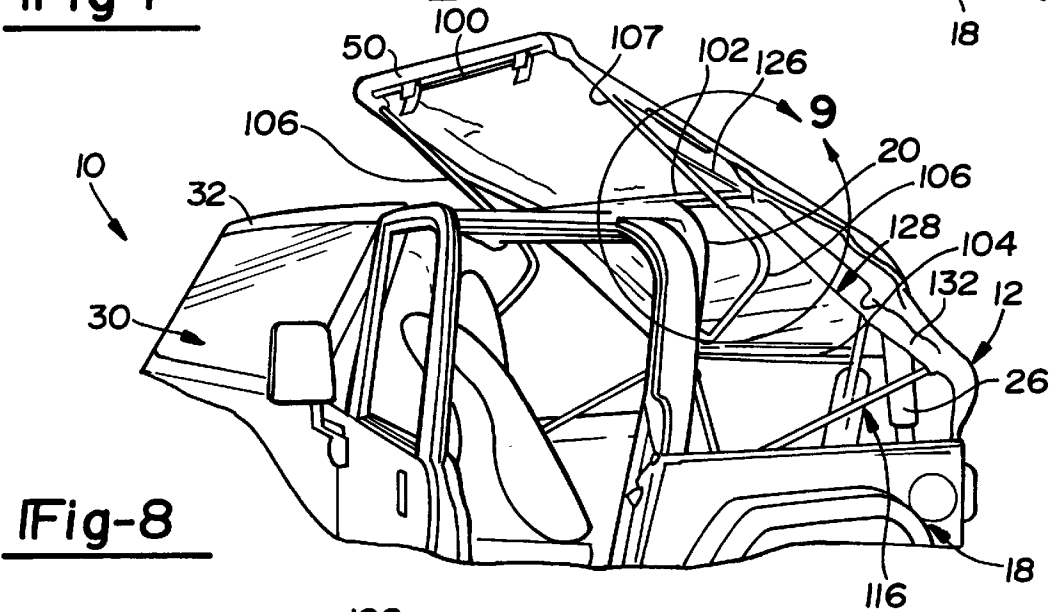
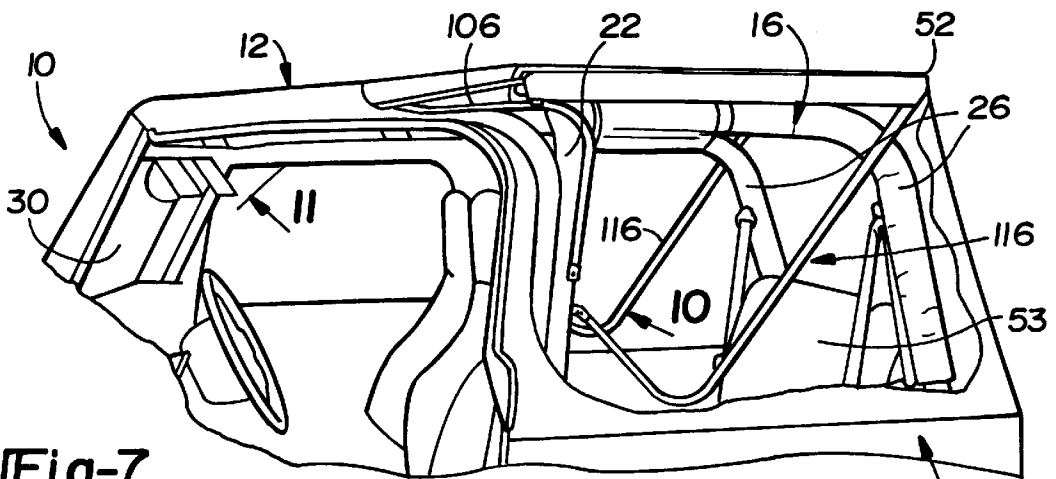

Fig-6



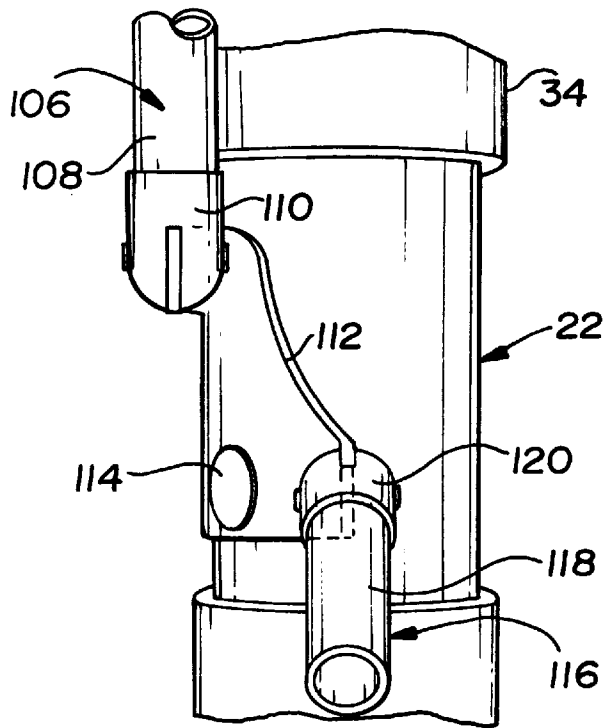

Fig-10

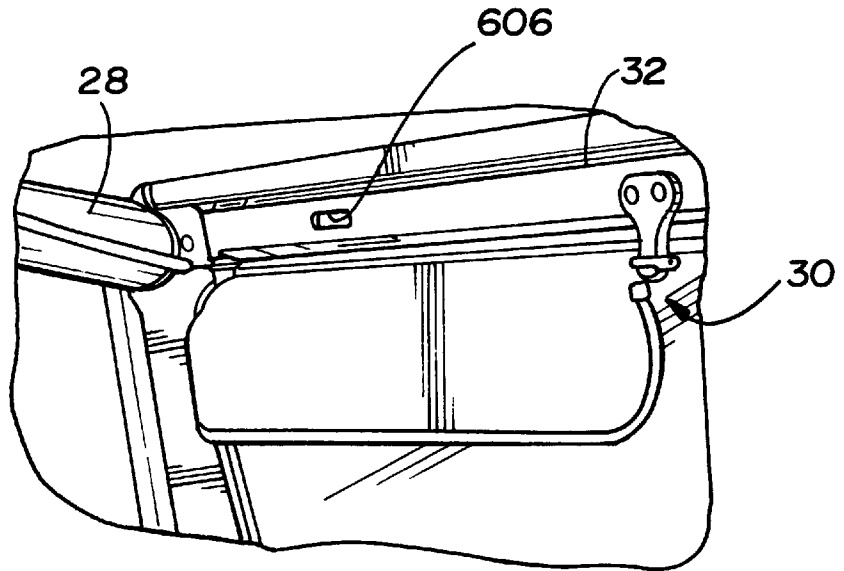

Fig-11

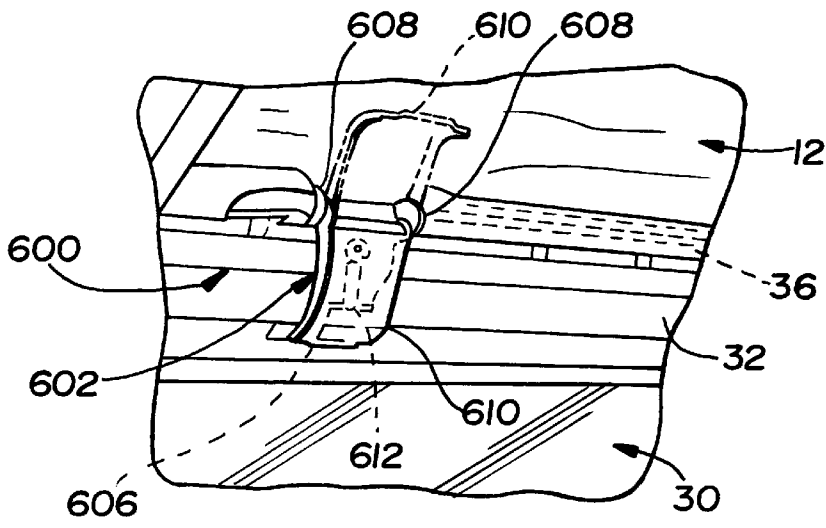

Fig-12A

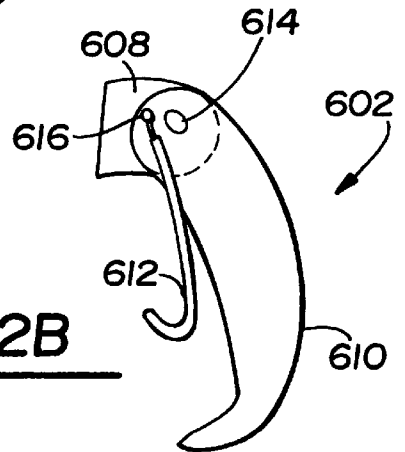

Fig-12B

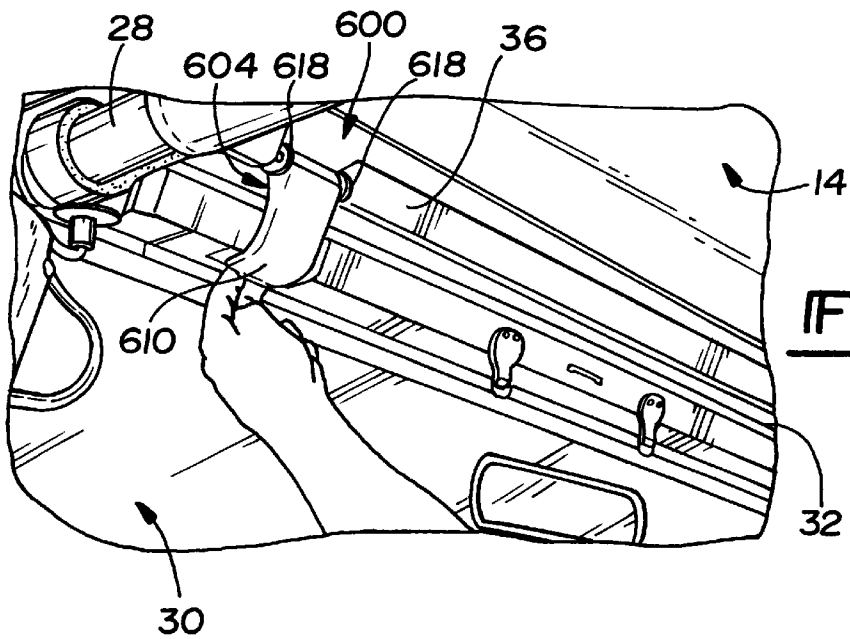

Fig-13

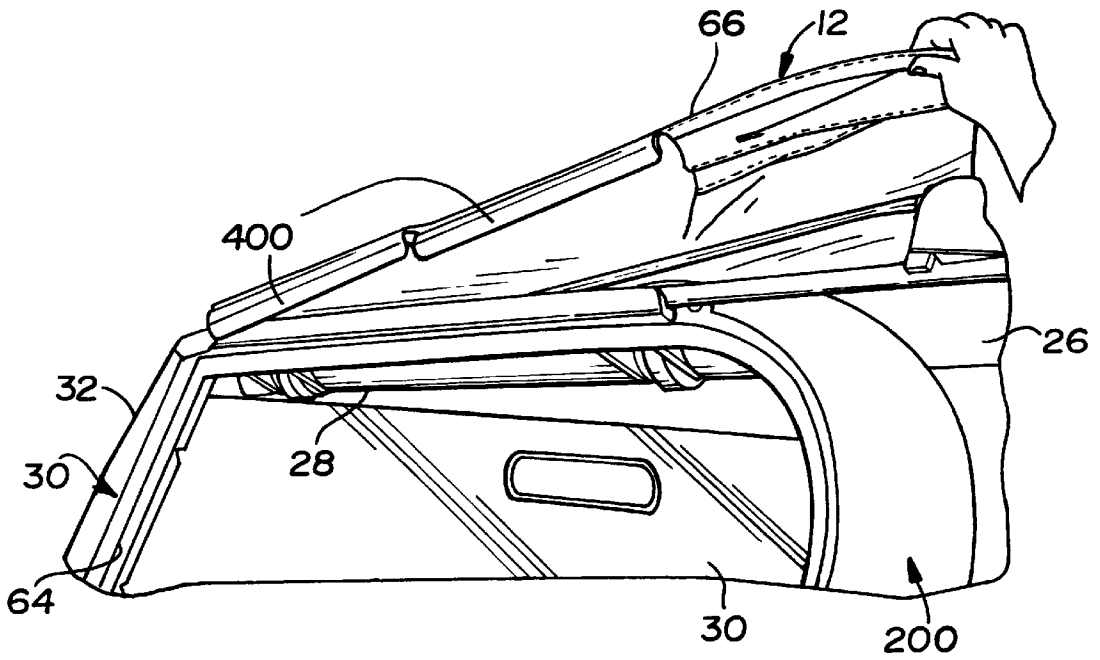

Fig-14

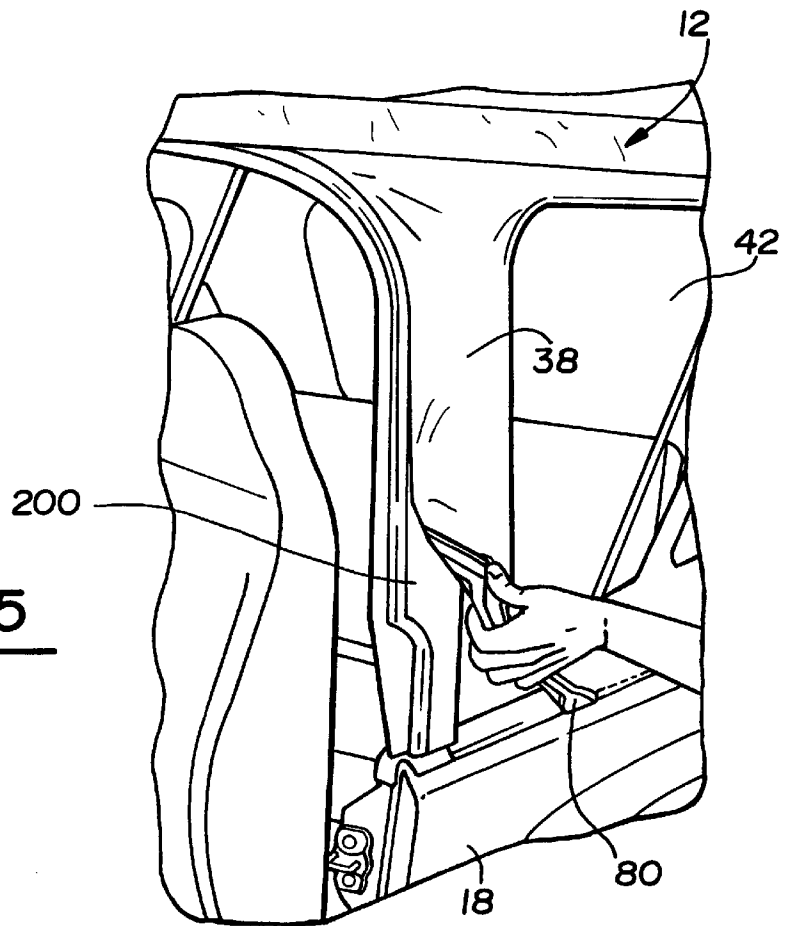
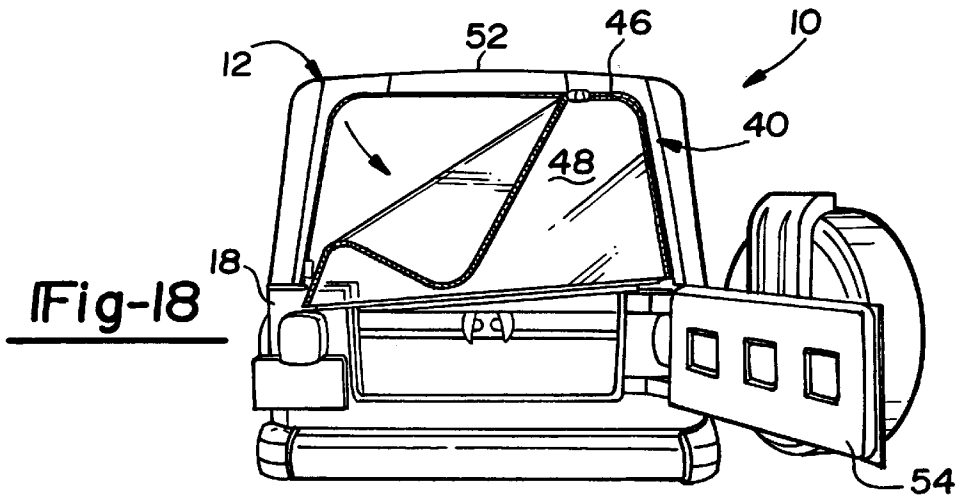
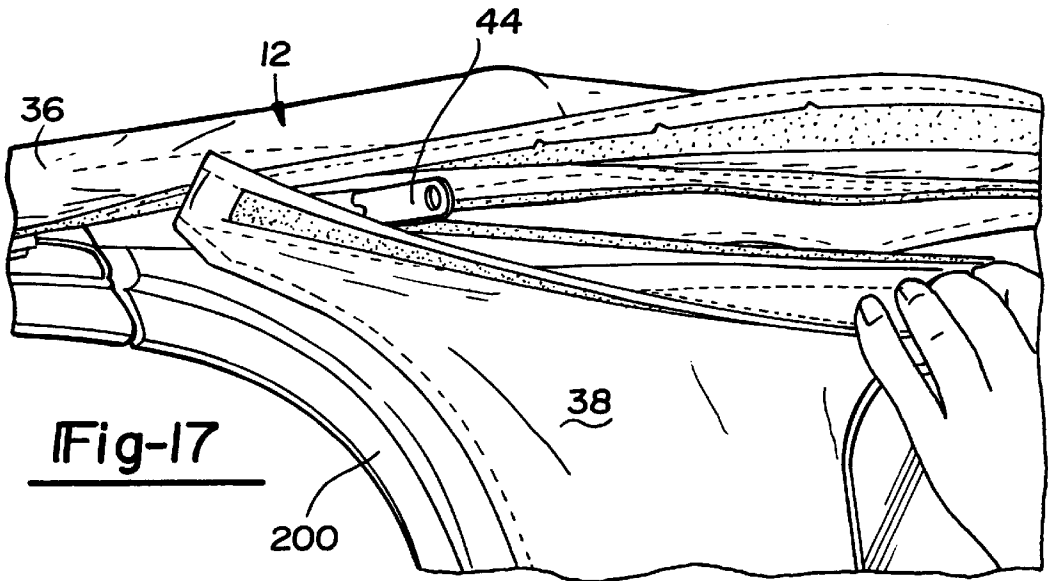
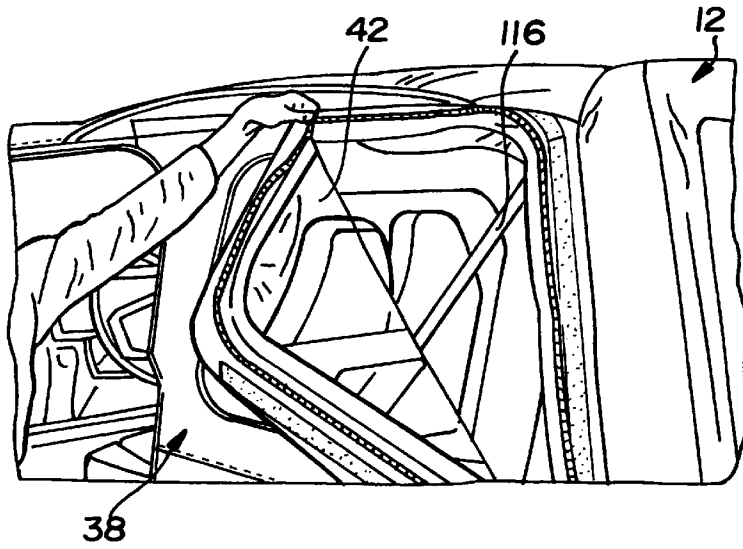

Fig-15



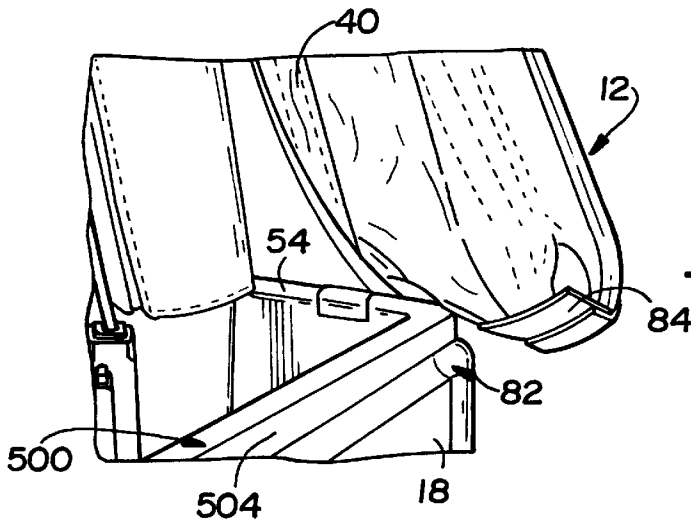

Fig-19

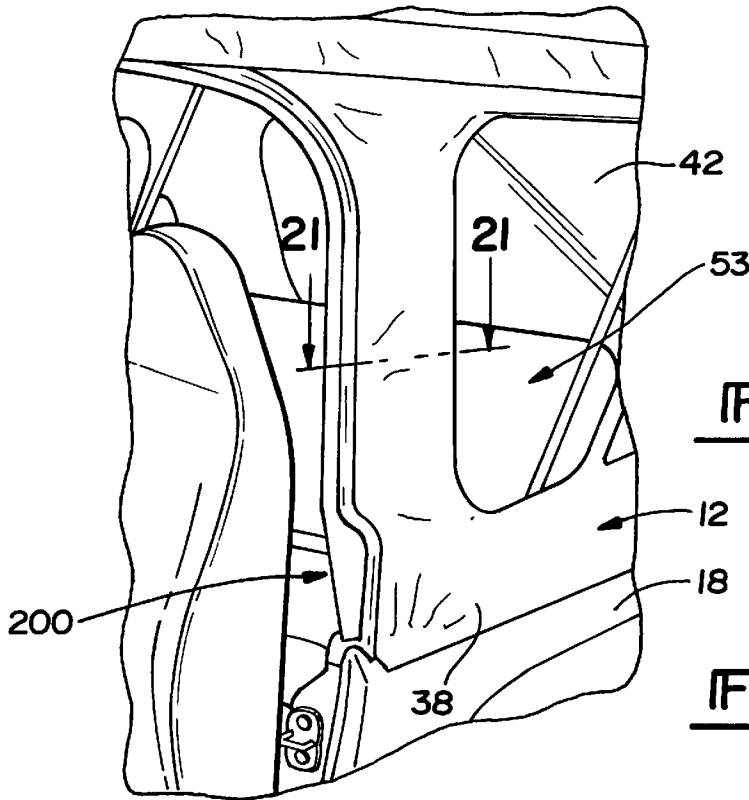

Fig-20

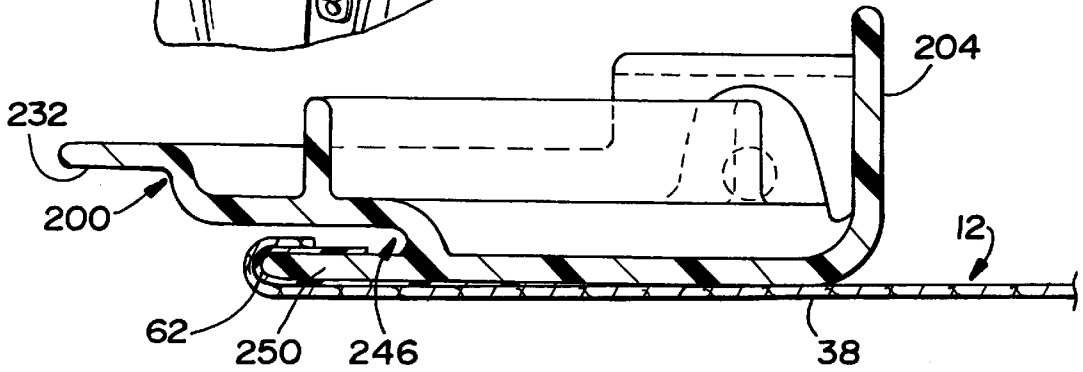

Fig-21

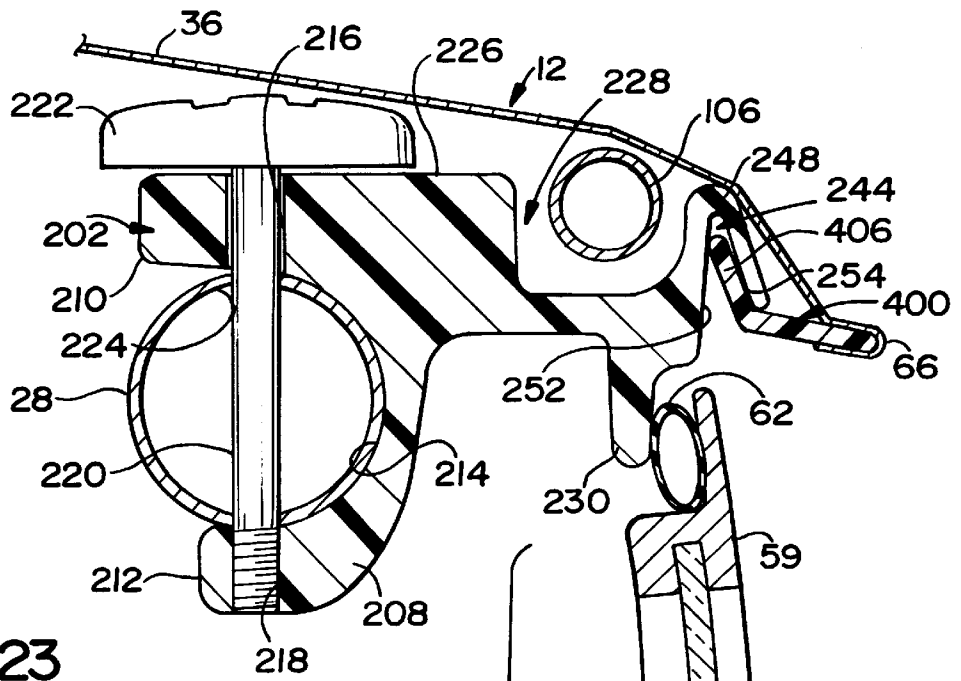

Fig-23

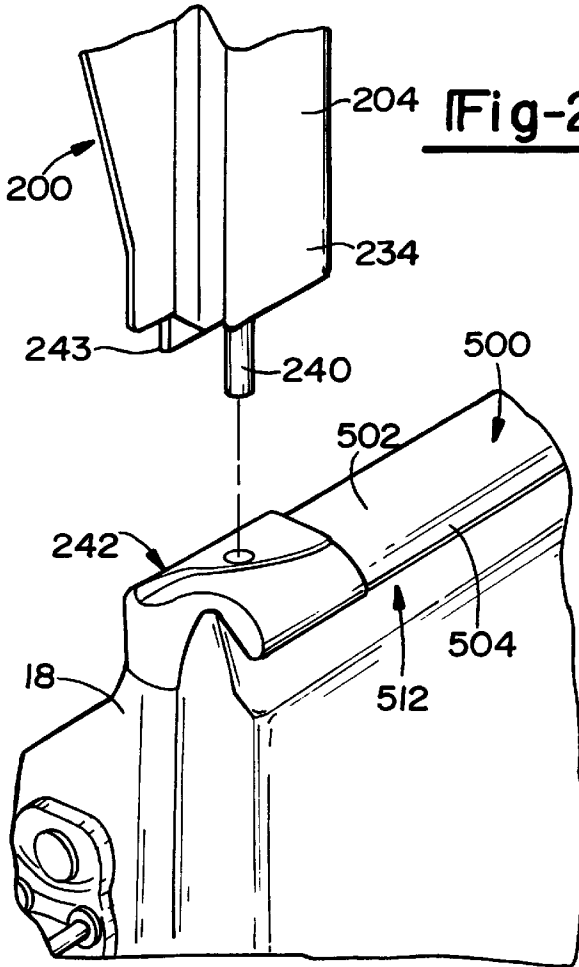
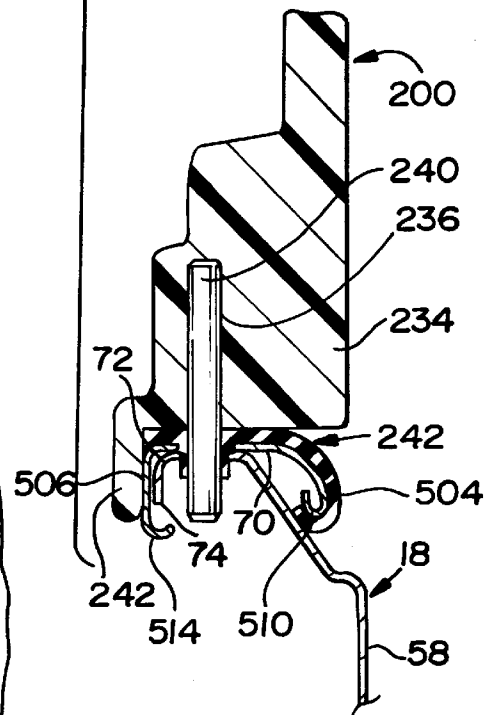

Fig-22



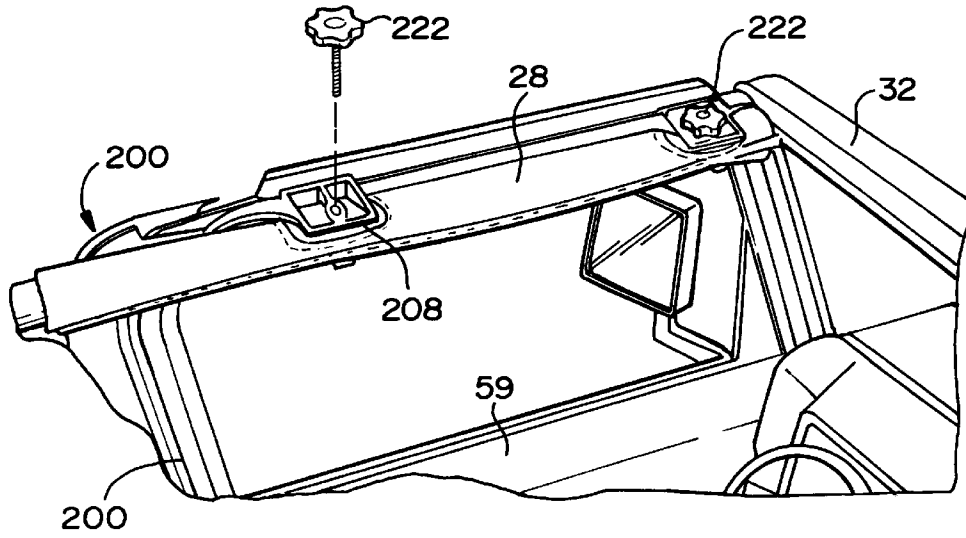

Fig-24

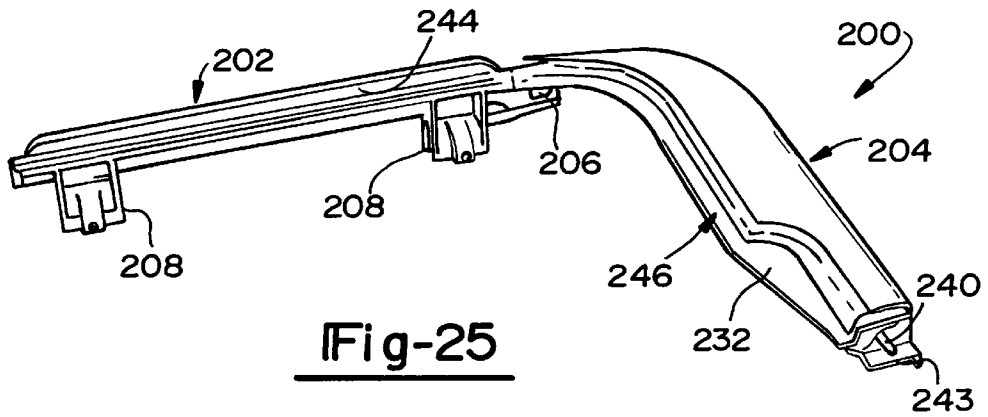

Fig-25

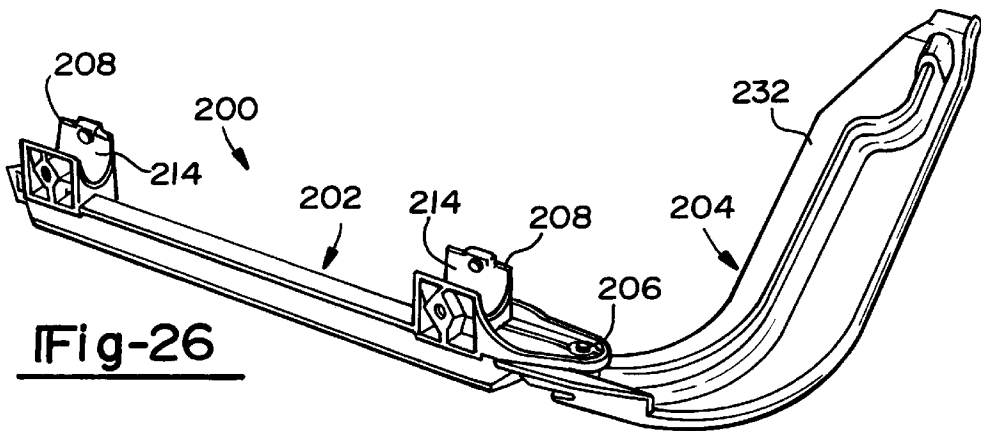
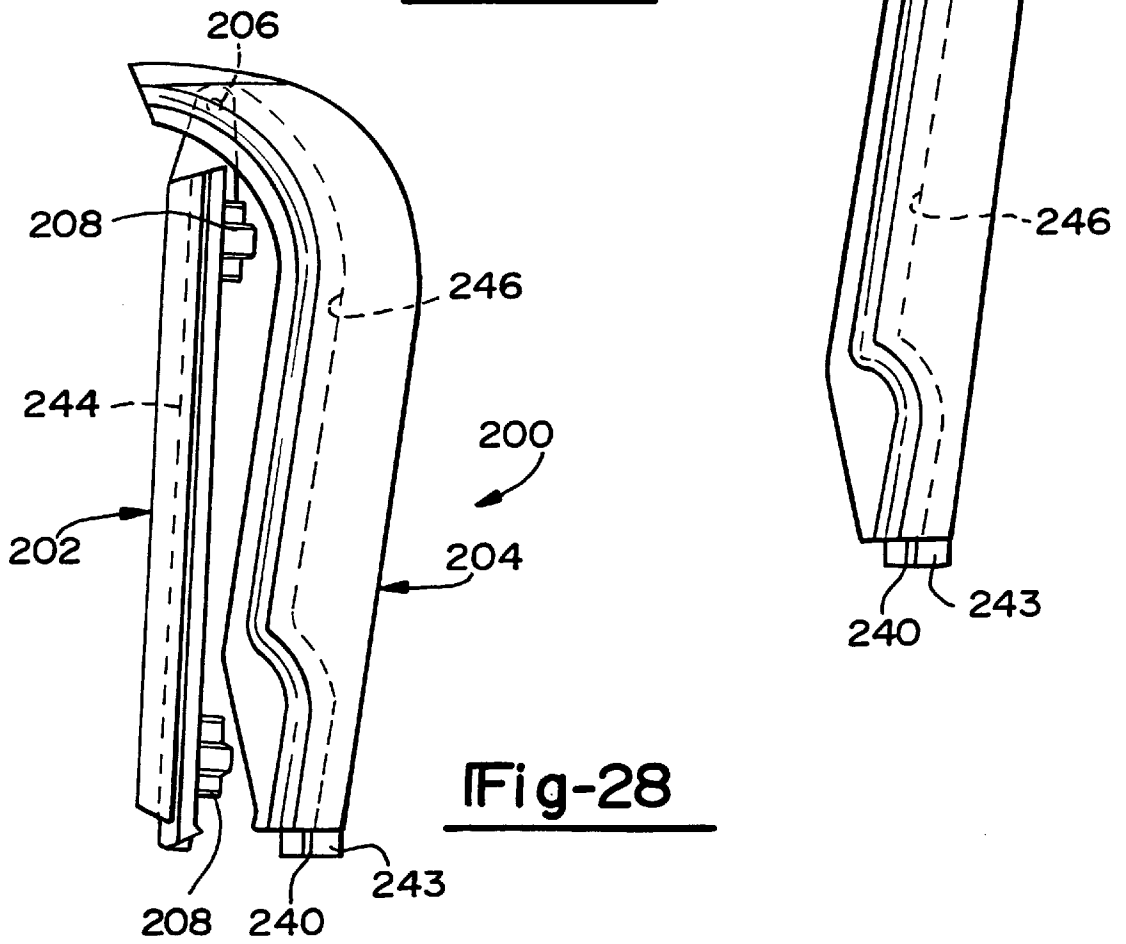
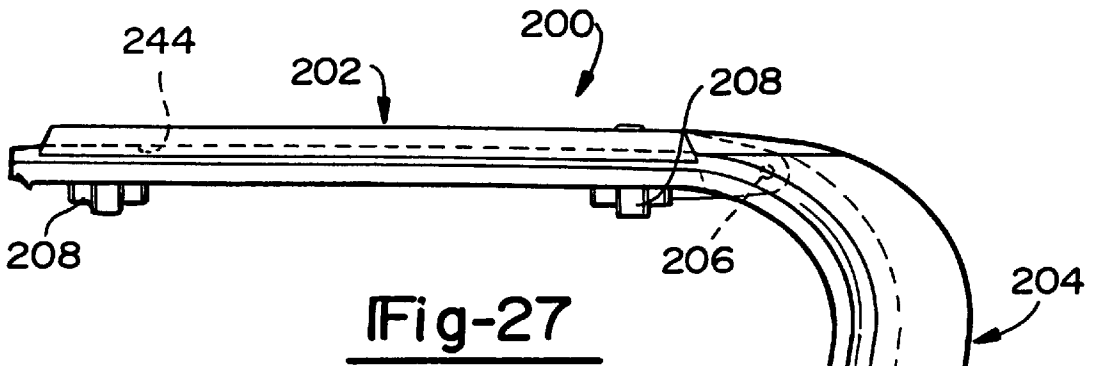

Fig-26



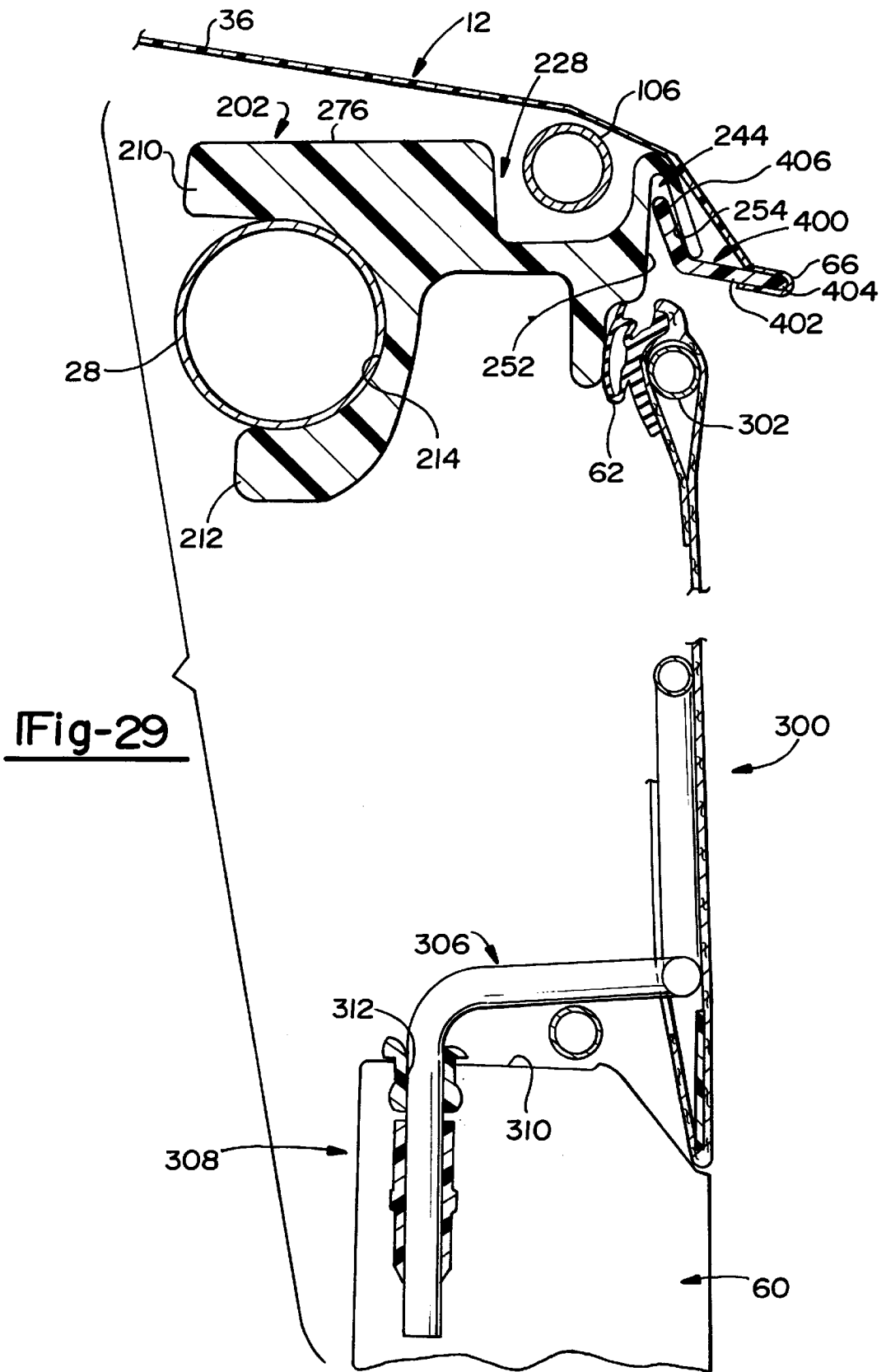

Fig-30

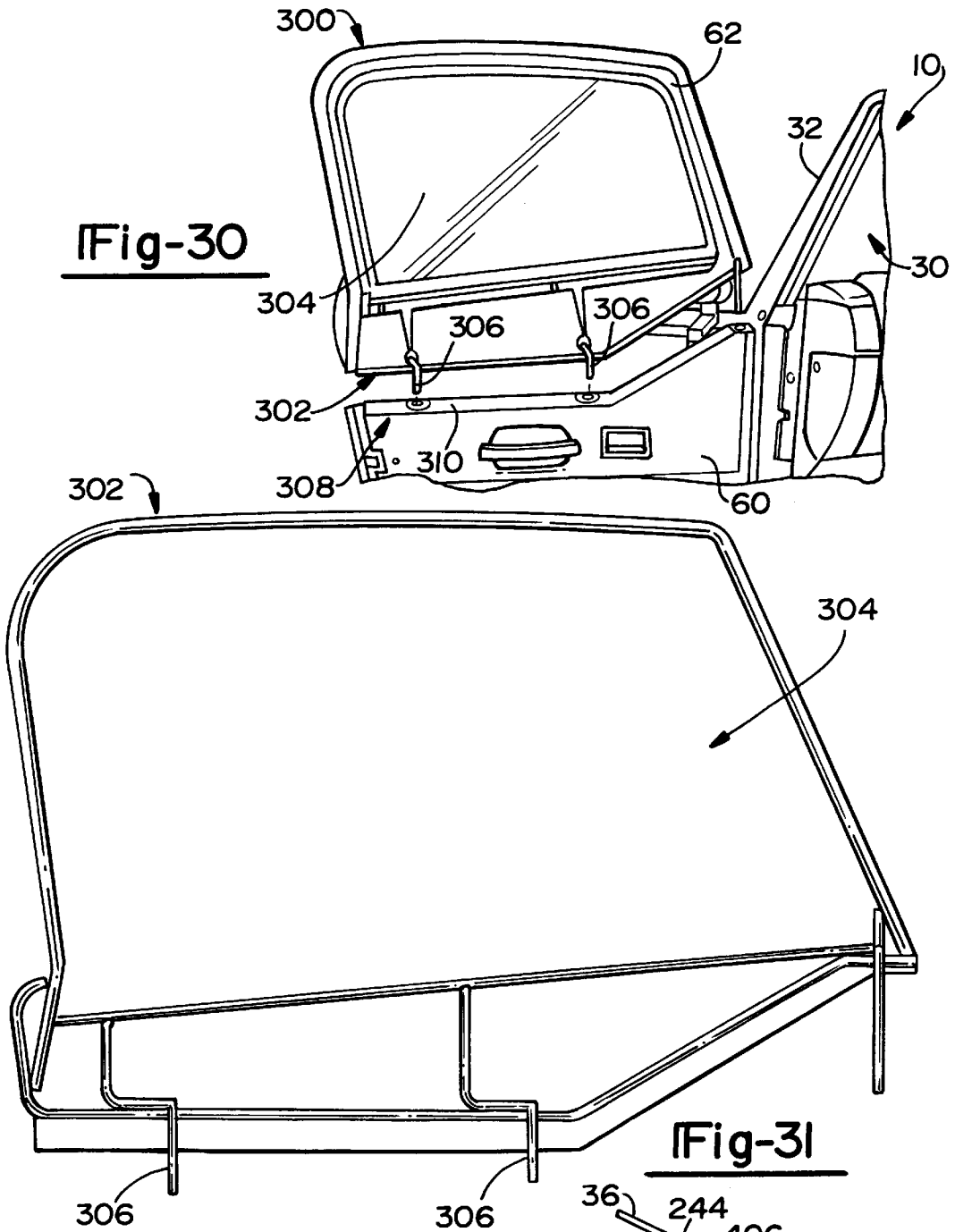

Fig-31

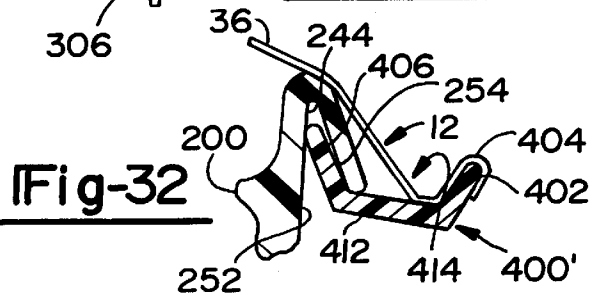
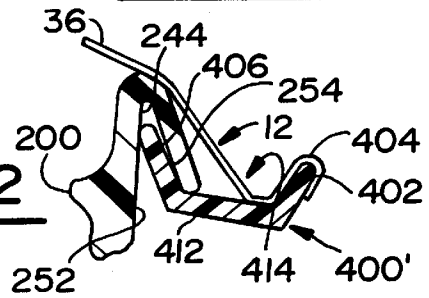

Fig-32



APPARATUS FOR ATTACHING A SOFT TOP TO A MOTOR VEHICLE

CROSS-REFERENCE TO RELATED APPLICATIONS

This is a conventional application based on the provisional applications assigned the following U.S. Ser. Nos.: U.S. Ser. No. 60/029,154, filed Oct. 22, 1996 U.S. Ser. Nos. 60/028,994; 60/028,995; 60/028,996; 60/028,997; 60/028,998; 60/028,999 all filed Oct. 23, 1996; and 60/029,737, filed Nov. 23, 1996.

BACKGROUND OF THE INVENTION

1. Field of the Invention

The present invention relates generally to motor vehicles. More particularly, the present invention relates to an apparatus for attaching a soft top to the body of a motor vehicle.

2. Discussion

It is well known in the motor vehicle art to provide a convertible top which may be folded back or removed from the vehicle. In one common form, the convertible top is constructed of a flexible fabric (referred to as a soft top) and can be folded back to a storage position or otherwise removed from an installed position. In another common form, the convertible top is constructed from a rigid material such as plastic and/or metal (referred to as a hard top) and is intended to be completely removed from the vehicle.

Soft tops are desired by a large segment of purchasers since they provide the user with the benefit of open air driving while affording available protection in the event of adverse weather conditions. Most known soft tops are designed to be easily retracted to a stored position, either under a source of power or manually. Other factors which make soft tops desirable include less associated expense, readily removable panels, and compact storage size. Among other advantages, vehicle hard tops provide for greater comfort and noise due to reduced wind and road noise and improved insulation from extreme ambient conditions.

It is also known in the art of motor vehicles to provide a single motor vehicle designed to cooperate with both a soft top and a hard top. One such vehicle is sold by the assignee of the present application under their registered trademark JEEP. While JEEP® brand vehicles having top systems with both a soft top and a hard top have been extremely popular with consumers, it remains desirable to further improve certain aspects of such top systems. The present invention addresses improvements to known top systems for motor vehicles, including the top system for JEEP® brand vehicles.

SUMMARY OF THE INVENTION

It is a principal object of the present invention to provide a rain shedding arrangement for a soft top of a motor vehicle which forces water (e.g. rain and condensation) to fall below and away from the top of the door, thereby preventing water intrusion onto the seal.

In one form, the present invention provides a retainer member for attaching a lateral edge of a soft top to a structural element of a motor vehicle, the structural element defines a channel which opens in a downward direction. The retainer element includes a first portion and a second portion. The first portion is adapted to fixedly attached to the lateral edge of the soft top. The second portion is adapted to be inserted into the channel of the structural element and cooperate with the channel to oppose a bending moment introduced by tensioning of the soft top in a lateral direction.

In another form, the present invention provides a top system for a motor vehicle. The top system includes a fabric top having a top section with a pair of laterally spaced apart sides. The top system further includes a door frame attached to the motor vehicle. The door frame defines a molded-in-recess. The top system further includes a retainer element interconnecting the door frame and the fabric soft top. The retainer element includes a first portion fixedly attached to one of the laterally spaced apart sides of the fabric soft top and a second portion retained by an interference fit within the molded-in-recess of the door frame.

BRIEF DESCRIPTION OF THE DRAWINGS

FIG. 1 is a front perspective view of an exemplary motor vehicle incorporating the teachings of the preferred embodiment of the present invention, shown with the soft top in an operative position.

FIG. 2 is a fragmentary view of the exemplary motor vehicle of FIG. 1 illustrating the soft top folded to a retracted or stored position.

FIG. 3 is a front perspective view similar to FIG. 1, illustrating the exemplary motor vehicle with the hard top operatively mounted over the soft top.

FIG. 4 is a cutaway view of a portion of the motor vehicle of FIG. 3 further illustrating the soft top stored within the hard top.

FIG. 5 is a partial cross-sectional view taken along the line 5—5 of FIG. 3.

FIG. 6 is a view of an interior portion of the motor vehicle of FIG. 4 taken in the direction of Arrow 6 of FIG. 4 illustrating attachment of the hard top to the body of the motor vehicle.

FIG. 7 is an enlarged side view of a portion of the exemplary motor vehicle of FIGS. 1 and 2, partially cutaway to illustrate the support arrangement for the soft top.

FIG. 8 is an enlarged partial view of the exemplary motor vehicle of FIGS. 1 and 2 similar to FIG. 7, illustrating the soft top rotated to an intermediate position.

FIG. 9 is an enlarged view detailing the area identified in Circle 9 of FIG. 8.

FIG. 10 is an enlarged view taken in the direction of Arrow 10 of FIG. 7 showing a portion of the padding cut-away from the main hoop of the sport bar assembly to illustrate the mounting bracket for the bows of the soft top.

FIG. 11 is a view of an interior portion of the exemplary motor vehicle of FIGS. 1 and 2 taken in the direction of Arrow 11 in FIG. 7.

FIG. 12A is a view similar to FIG. 11, illustrating the latching arrangement of the top system of the present invention interconnecting the soft top to the windshield frame.

FIG. 12B is a side view of the latching arrangement of FIG. 12A.

FIG. 13 is a view similar to FIG. 11, illustrating the latching arrangement of the top system of the present invention interconnecting the hard top to the windshield.

FIG. 14 is another enlarged perspective view of a portion of the exemplary motor vehicle of FIGS. 1 and 2, illustrating the step of attaching the deck fabric retainers into a horizontally oriented molded-in channel provided in a removable door frame assembly.

FIG. 15 is another perspective view of a portion of the exemplary motor vehicle of FIG. 1 and, illustrating the step of attaching the forward retainer in the quarter window into

a vertically oriented molded-in channel provided in the removable door frame assembly.

FIG. 16 is an enlarged perspective view of a portion of the exemplary motor vehicle of FIGS. 1 and 2, illustrating the step of attaching one of the side windows to the soft top.

FIG. 17 is a further enlarged view of a portion of the exemplary motor vehicle of FIGS. 1 and 2.

FIG. 18 is a rear view of the exemplary motor vehicle of FIGS. 1 and 2, illustrating the step of attaching the rear window to the soft top.

FIG. 19 is a perspective view illustrating the step of attaching the rear corner retainers for the soft top.

FIG. 20 is an enlarged view of a portion of the exemplary motor vehicle of FIGS. 1 and 2.

FIG. 21 is a cross-sectional view taken along the line 21—21 of FIG. 20.

FIG. 22 is a cross-sectional vertically view taken through the removable door frame assembly of the present invention as it is operatively attached to the motor vehicle.

FIG. 23 is an exploded view of a portion of the motor vehicle of FIGS. 1 and 2, illustrating the interconnection between the vehicle body and the removable door frame assembly.

FIG. 24 is a top view of a portion of the motor vehicle of FIGS. 1 and 2 illustrating attachment of the removable door frame assembly to the sport bar assembly.

FIG. 25 is a perspective view of one of the removable door frame assemblies of the present invention.

FIG. 26 is another perspective view of the removable door frame assembly of FIG. 25.

FIG. 27 is a side view of the removable frame member of FIG. 20 illustrated in its operative position.

FIG. 28 is a side view of the removable door frame assembly of FIG. 20 illustrated collapsed to a stored position.

FIG. 29 is a cross-sectional view vertically taken through the removable window assembly of the present invention as it operatively attached to the motor vehicle.

FIG. 30 is a rear side view of the removable window assembly of the present invention illustrated prior to attachment to the lower door assembly of the motor vehicle.

FIG. 31 is a rear side view of the frame of the removable window assembly of the present invention.

FIG. 32 is a portion of the cross-sectional view of FIG. 22 illustrating an alternative retainer element for interconnecting the soft top and the removable door frame assembly.

DETAILED DESCRIPTION OF THE PREFERRED EMBODIMENT

The present invention relates to various aspects of an improved top system for a motor vehicle. As will become apparent from the remainder of this detailed description, the present invention more particularly relates to features of a top system which preferably includes both a hard top and a soft top. These features, which are described in detail below, are shown in the drawings cooperatively arranged within a single preferred embodiment. However, it will be appreciated that the scope of the present invention as it independently relates to each of the features described is not so limited. In other words, while a preferred embodiment of a motor vehicle is shown and described, it will be understood that the various features may be utilized independent from one another. Furthermore, it will be understood that the remainder of the motor vehicle illustrated throughout the

drawings is only exemplary, the teachings of the present invention being applicable for a wide range of applications.

The principal features of the present invention which will be discussed in detail below relate to: (1) an apparatus for articulating the soft top between an operative position and a stored position; (2) a removable door frame assembly; (3) a removable door window assembly; (4) a retainer member for attaching the soft top to the motor vehicle and shingling water away from the vehicle; (5) a multi-purpose retainer for the motor vehicle which facilitates selective attachment of the hard top and the soft top; (6) a latching arrangement for latching one of the tops to the motor vehicle; and (7) a top system in which the hard top may be operatively installed over the soft top. Prior to addressing the particular features of the present invention, a brief introduction of the exemplary vehicle as it relates thereto is warranted.

Turning generally to the drawings, an exemplary motor vehicle shown to include a top system constructed in accordance with the teachings of the present invention is generally identified with reference numeral 10. The motor vehicle 10 will be understood to be generally of the type sold by Chrysler Corporation, the assignee of this application, under their registered trademark JEEP. FIG. 1 shows the exemplary motor vehicle 10 with a soft top 12 installed to an operative position to protect passengers in the occupant compartment from wind, rain and other adverse weather conditions. FIG. 2 is an enlarged side view of the exemplary motor vehicle 10 shown with the soft top 12 folded to a stored position. In a manner which will be described below, the soft top 12 may be articulated between its operative position and its stored position. FIG. 3 shows the exemplary motor vehicle 10 with a hard top 14 mounted thereon.

The exemplary motor vehicle 10 is shown to include a sport bar assembly 16 which upwardly extends from the vehicle body 18. The sport bar assembly 16 is shown most clearly in FIG. 2 to include a main hoop 20 which is generally U-shaped. The main hoop 20 includes a pair of laterally spaced apart vertical members 22 interconnected by a transverse member (not shown). The sport bar assembly 16 is shown to further include a pair of rear hoops 26 welded to the main hoop 20 and extending rearward therefrom. Further, the sport bar assembly 16 includes a pair of side bars 28 bolted to the main hoop 20 and forwardly extending adjacent to a vehicle windshield assembly 30. The side bars 28 are received in cylindrical recesses (not shown) provided in a frame 32 of the windshield assembly 30. The sport bar assembly 16 is shown in the drawings partially covered with suitable padding 34.

The soft top 12 is constructed of fabric and illustrated to generally include a top section 36, laterally spaced apart side sections 38, and a rear section 40. A quarter window 42 is attached to each of the laterally spaced apart side sections 38 with a zipper 44. In a similar manner, a zipper 46 attaches a rear window 48 to the rear section 40.

With the foregoing description of the exemplary motor vehicle 10 as background, the various specific features of the present invention will now be described.

I. Apparatus for Articulating the Soft Top Between an Operative Position and a Stored Position

With specific reference to FIGS. 2, 4, 5 and 7-10, the motor vehicle 10 is shown to include an apparatus for articulating the soft top 12 between the operative position and the stored position. As will become apparent below, the apparatus further functions to support the soft top 12 in its operative position.

The apparatus for articulating the soft top 12 has a plurality of support members including a forward support member 100 (or #1 bow), an intermediate support member 102 (or #2 bow), and a rearward support member 104 (or #3 bow). The #1 bow comprises a header portion 100 which is conventionally sewn within a forward edge 50 of the top section 36 of the soft top 12 (shown in FIG. 12). The #2 bow 102 transversely extends across the underside of the soft top 12 for supporting the fabric of the soft top 12 in a cross-car direction and the #3 bow 104 supports an upper rear corner 52 of the soft top 12 when the soft top 12 is in the operative position.

The #1 bow 100 is interconnected to the motor vehicle 10 for rotation about a first transverse pivot axis through a pair of side bows 106. The side bows 106 are each generally L-shaped, having a first end 107 operatively interconnected with the #1 bow 100 and a second end 108 pivotally attached to the main hoop 20 of the sport bar assembly 16. The second ends 108 of the side bows 106 are each received in a knuckle 110 which is pivotally attached to a respective mounting plate 112. The mounting plate 112 is fixedly attached to an associated vertical member 22 of the main hoop 20 of the sport bar assembly 16 with threaded fasteners 114. The second ends 108 of the side bows 106 cooperate to define the first transverse pivot axis.

The #3 bow 104 extends in a transverse direction and is captured within the upper rear edge 52 of the soft top 12. The #3 bow 104 is preferably integrally formed with a pair of L-shaped members 116 which function to pivotally interconnect the #3 bow 104 to the motor vehicle 10 for rotation about a second transverse pivot axis. Both of the L-shaped members 116 of the #3 bow 104 include an end 118 which is received into a knuckle 120 pivotally attached to the mounting plate 112. The ends 118 of the L-shaped members 116 cooperate to define the second transverse pivot axis. In the preferred embodiment, the first and second transverse pivot axes are spaced apart from each other both vertically and horizontally.

As shown most clearly in the top sectional view of FIG. 5, the L-shaped members 116 attaching the #3 bow 104 to the sport bar assembly 20 both diverge in an outboard direction as they extend from the sport bar assembly 20. This geometry provides a full shape for the soft top 12 in its operative position while allowing the plurality of support members 100, 102, and 104 to be positioned entirely within the body 18 of the vehicle 10 when the soft top 12 is stored. The significance of this feature will become more apparent below when concurrent mounting of the hard top 14 and the soft top 12 to the motor vehicle 10 is described.

The specific manner in which the soft top is installed is described below. Briefly, when the side sections 38 and the rear section 40 of the top 12 are attached to the motor vehicle 10, the L-shaped members 116 are permitted to flex. Such flexing provides a spring load which serves as a counterforce to the fabric of the soft top 12, thereby retaining the soft top 12 in a taut condition.

The #2 bow 102 includes two downwardly extending ends 121 (shown most clearly in FIG. 9) which are supported on an associated one of the side bows 106 when the soft top 12 is in its installed position. To this end, each downwardly extending end 121 of the #2 bow 102 is attached to a support member 122 which defines a groove 124 for receiving one of the side bows 106. The #2 bow 104 is preferably pivotally interconnected to each of the side bows 106 through a link rod 126.

The apparatus for articulating the soft top 12 of the present invention further includes a pair of tension straps

128. Each of the tension straps 128 includes a first end 130 attached to one of the downwardly extending ends 121 of the #2 bow 102 and a second end 132 attached to one of the side bows 106 immediately adjacent the #3 bow 104. The tension straps 128 cooperate to draw the soft top 12 taut in a longitudinal direction when the soft top 12 is in its operative position.

When the soft top 12 is articulated from its stored position (shown in FIG. 2), through an intermediate position (shown in FIG. 8), and ultimately to an operative position (shown in FIG. 1), the side bows 106 function to carry the #1 bow 100 and the #2 bow 102 through corresponding pivoting arcs from a cavity located between the rear seat 53 and the tailgate 54 to the top of the windshield frame 32. Concurrently, the #3 bow 104, which when the soft top 12 is in its operative position frames and supports the upper rear corner 52 of the soft top 12, pivots about the second transverse pivot axis which is disposed immediately rearward and below the first transverse pivot axis. The #3 bow 104 pivots down to rest on the top of the rear wheel house panels 56 which are inboard of the body side panels 58 and forward of the tailgate 54. As the side bows 106 articulate forward, the #2 bow 102 pivots on the side bows 102 to clear the rear hoops 26 of the sport bar assembly 16. The #2 bow 102 comes to rest on the top of the L-shaped members 116, and the side bow 106 and the #1 bow 100 come to rest on top of the #2 bow 102.

In the stored position, the fabric of the soft top 12 is attached to the #1, #2, and #3 bows 100, 102 and 104 and is folded around and into a stowed bow assembly to form a minimal visible stack. A wrap or boot (not shown) may be used to gather the loose fabric and also may be used to contain the rear and quarter windows 48 and 42.

II. Removable Door Frame Assembly

With specific reference to FIGS. 14, 15 and 20-28, the top system of the present invention is shown to include a removable door frame assembly 200. The removable door frame assembly 200 shown throughout the drawings is specifically configured for the driver's side of the motor vehicle 10. However, it will be understood by those skilled in the art that the exemplary motor vehicle 10 includes a removable door frame assembly for the passenger's side which is a substantial mirror image thereof. As will become apparent below, the removable door frame assembly 200 continues the shut-face or opening aperture into which either a full door 59 or a removable window assembly 300 for a lower door assembly 60 sits. The removable door frame assembly 200 further functions to retain the top section 36 of the soft top 12 in a cross-car direction and the side section 38 of the soft top 12 in a longitudinally direction.

The removable door frame assembly 200 is shown to include a first portion 202 which is adapted to releasably engage the motor vehicle 10 in a horizontal orientation and a second portion 204 adapted to releasably engage the motor vehicle 10 in a vertical orientation. Preferably, the first and second portions 202 and 204 are pivotally interconnected with a pin 206. Such pivotal interconnection permits the removable door frame assembly 200 to be folded (as specifically shown in FIG. 28), thereby facilitating storage within the motor vehicle 10 upon removal.

With particular reference to the cross-sectional view of FIG. 22, the first portion 202 of the removable door frame assembly 200 is integrally formed to include a pair of mounting portions 208. The mounting portions 208 are similarly constructed to include an upper flange 210 and a

lower flange **212** which cooperate to partially define an arcuate recess **214**. The arcuate recess **214** is sized to receive one of the side bars **28** of the sport bar assembly **16**. The upper and lower flanges **210** and **212** are formed to include aligning apertures **216** and **218**, respectively, adapted to receive a threaded fastener **220**. The fastener **220**, which has an oversized head **222** to facilitate manual installation, is passed through the aperture **216** in the upper flange **210**, through an aperture **224** in the side bar **28**, and engages a captured nut (not specifically shown) provided in the lower flange **212**.

An upper side **226** of the first portion **202** is integrally formed to include a longitudinally extending recess **228** which accommodates an adjacent one of the side bows **106** when the soft top **12** is in the operative position. The first portion **202** is further integrally formed to include a downwardly extending lip **230** which partially defines the door shut-face. The downwardly extending lip **230** is adapted to abut a seal **62** carried by the full vehicle door **59** or the removable window assembly **300**.

The second portion **204** of the removable door frame assembly **200** is integrally formed to include a lip or flange **232** (shown most clearly in FIG. **21**) which forwardly extends and cooperates with the downwardly extending lip **230** of the first portion **202** to partially define the door shut-face. A lower end **234** of the second portion **204** is formed to include a cylindrical aperture **236** for receiving a locating pin **240**. The locating pin **240** is adapted to engage a B-pillar grommet assembly **242** carried by the vehicle body **18**.

The lower end **234** of the second portion **204** is further integrally formed to include a downwardly extending flange **243** which cooperates with the body **18** of the vehicle **10** to prevent rotation of the second portion **204** relative to the motor vehicle **10**. Thus, the pin **240** and flange **243** cooperate to provide positive containment of the removable door frame assembly **200** in the longitudinally and cross-car directions, while being passive in a vertical direction. Vertical containment of the removable door frame assembly **200** is managed through the molded upper and lower flanges **210** and **212** of the first portion **202** which are attached to the side bar **28**.

The first and second portions **202** and **204** of the removable door frame assembly **200** are formed to include molded-in-channels **244** and **246**, respectively, for retaining the soft top **12** in an operative position. In this regard, the molded-in-channel **244** of the first portion **202** extends in a generally longitudinally direction and is adapted to removably receive a retainer element **400** fixedly attached to the top section **36** of the soft top **12**. As shown most clearly in the cross-sectional view of FIG. **22**, the molded-in-channel **244** of the first portion **202** is defined by a generally U-shaped segment **248** of the first portion **202** which opens downwardly. The distal end of the segment **248** is angled slightly outward as it extends down to facilitate entry of the retainer element **400**. The retainer element **400**, which is described in more detail in Section IV below, is retained under the tension of the top section **36** of the soft top **12**, thereby retaining and tensioning the soft top **12** in a cross-car direction.

In a similar manner, the molded-in-channel **246** (shown most clearly in FIG. **21**) of the second portion **204** of the removable door frame assembly **200** is defined by a generally U-shaped segment **250** which is adapted to receive a portion of a U-shaped forward retainer element **62** fixedly attached to the side portion **38** of the soft top **12**. In the

preferred embodiment, the retainer elements **62** and **400** are attached to their associated portions of the soft top **12** through stitching (not shown). The molded-in-channel **246** of the second portion **204** functions to longitudinally retain the side section **38** of the soft top **12**.

III. Removable Door Window Assembly

With specific reference to FIGS. **29–31**, the removable window assembly **300** of the present invention is shown to include a wire window frame **302** which defines a window opening **304** and a mounting arrangement for removably attaching the wire window frame **302** to the lower door assembly **60**. In the exemplary embodiment illustrated, the mounting arrangement includes a plurality of wire pins **306** interconnected to the window frame **302** in a corresponding plurality of grommet assemblies **308** provided in an upper surface **310** of the lower door assembly **60**. The wire pins **306** are preferably L-shaped so as to position the outer surface of the door and its seals relative to the grommet assemblies **308**.

The wire of the wire window frame **302** has a diameter sufficient to hold it against the seal flange (not specifically shown) carried by the windshield frame **32**. The grommet assemblies **308** define apertures **312** for receiving the pins **306** as a result of limited clearance between the pins **306** and their corresponding apertures **312**, the window frame **302** must be lifted in a substantially vertical direction in order to remove it from the lower door assembly **60**.

The window frame **302** is configured to cooperate with the shut-face surface which is cooperatively provided by the lateral edge **64** of the windshield frame **32** and the removable door frame assembly **200**. In this regard, the downward extending flange **230** of the removable door frame assembly **200** and a similar flange provided by the lateral edge **64** of the windshield frame **32** to prevent removal of the window frame **302** when the lower door assembly **60** is in the closed position. The lateral side **64** of the windshield frame **32** and the removable door frame assembly **200** laterally extend beyond the window frame **302**. Thus, the windshield frame **32** and the removable door frame assembly **200** cooperate as a passive interference device to prevent the window frame **302** from being removed when the lower door assembly **60** is closed while allowing the window frame **302** to be easily removed when the lower door assembly **60** is open.

IV. Retainer Member for Attaching the Soft Top to the Motor Vehicle

With specific reference to FIG. **14**, and the cross-sectional views of FIGS. **22** and **29**, the retainer elements **400** introduced above in Section II regarding the removable door frame assembly **200** will be further described. The retainer elements **400** functions to retain the fabric of the soft top **12** in a cross-car direction (i.e., a transverse direction) and further functions to shingle the vehicle door **59** or **60** by forcing water (e.g., rain and condensation) to fall away from the top of the door **59** or **60**, thereby preventing water intrusion.

As shown in the perspective view of FIG. **14**, the present invention preferably includes a pair of substantially identical retainer elements **400** which interconnect a lateral edge **66** of the top section **36** of the soft top **12** with the molded-in channel **244** of the first portion **202** of the removable door frame assembly **200**. Each retainer elements **400** is integrally formed of a rigid plastic material to include a first portion preferably in the form of a first flange **402**. The first flange **402** is adapted to be fixedly attached to the lateral

edge 66 of the soft top 12. In the exemplary embodiment, the lateral edge 66 of the soft top 12 wraps around an edge 404 of the first flange 402 and is sewn to the first flange 402.

Each of the retainer elements 400 is shown to further include a second portion 406. The second portion 406 is illustrated to preferably comprise a second flange adapted to be inserted into the molded-in channel or recess 244 of the removable door frame assembly 200 and cooperate with the channel 244 to oppose a bending moment introduced by tensioning of the soft top 12 in a lateral direction. The second flange 406 is shown to be preferably disposed at an obtuse angle relative to the first flange 402.

As shown in the cross-sectional views of FIGS. 22 and 29, the channel 244 defined by the removable door frame assembly 200 is integrally molded into the first portion 202 of door frame assembly 200 and opens in a generally downward direction. The opposing sides 252 and 254 which define the molded-in channel 244 retain the retainer member 400 in an interference fit. In this regard, the second flange 406 of the retainer element 400 is fully inserted into the channel 244. The tension of the fabric top 12 in a lateral direction introduces a bending moment to the retaining element 400 which is opposed through contact of the opposing sides 252 and 254 with the second flange 406, thus holding the soft top 12 cross-car between the doors 59. The first flange 402 laterally extends beyond the removable door frame assembly 200 so that condensation and rain is laterally carried away from the door 59.

Turning to FIG. 32, an alternative construction of a retaining member 400' is illustrated. In this construction, the first flange 402' is upwardly turned and interconnected to the second flange 406' through an intermediate portion 412. The first and second flanges 402' and 406' and the intermediate portion 412 cooperate to define a rain trough 414 for carrying water and condensation rearward. Preferably the fabric of the soft top 12 is attached (e.g., sewn) to both the intermediate portion 412 and the first flange 402'.

V. An Apparatus for Selectively Mounting the Hard Top and the Soft Top to the Motor Vehicle

With specific reference to FIGS. 2, 6, 19, 22 and 23, the present invention is shown to include an apparatus 500 for selectively mounting the hard top 14 and the soft top 12 to the motor vehicle 10. As will become apparent below, the apparatus for selectively mounting the hard top 14 and the soft top 12 further functions to cover a raw sheet metal edge of the body side panel 58 in an effective and cost efficient manner. Pertinent to the present invention, the body side panel 58 (shown most clearly in FIG. 22) of the motor vehicle 10 upwardly extends and includes a generally horizontal upper portion 70. The body side panel 58 also includes a downwardly extending distal flange 72 on the inboard side which terminates at a raw edge 74.

The apparatus comprises a retaining member 500 which is longitudinally elongated to extend the entire length of the body side panel 58 of the motor vehicle 10. The retainer member 500 is shown to generally include an intermediate portion 502, an outboard flange 504 and an inboard flange 506. The intermediate portion 502 is adapted to be horizontally oriented and fixedly attached to the generally horizontal upper portion 70 of the body side panel 58. In the preferred embodiment 502, the intermediate portion 502 is welded to the body side panel 58. As shown in FIG. 19, the retainer member 500 preferably extends around a rear corner 82 of the motor vehicle 10 and includes a substantially identical portion which is attached to a sheet metal panel adjacent the vehicle tailgate 54.

The upper surface of the intermediate portion 502 provides a flat surface for supporting the hard top 14. As shown in FIGS. 5 and 6, the hard top 14 includes an inwardly extending flange 76 which rests on the intermediate portion 502. Threaded fasteners 78 pass through apertures (not specifically shown) provided in the inwardly extending flange 76 and engage captured nuts 509 retained by the intermediate portion 502.

The outboard flange 504 downwardly extends from the intermediate portion 502 and terminates in an inner curled portion 510. The inner curled portion 510 is spaced apart from the outer surface of the body side panel 58 of the motor vehicle 10 and defines a gap 512 for receiving one or more rigid retainers 80 (identified in FIG. 15) attached to the bottom edge of the side section 38 of the soft top 12.

The inboard flange 506 extends downwardly beyond the downwardly extending distal flange 72 of the body side panel 58. The inboard flange 506 terminates at a curled inner edge 514. The curled inner edge 514 functions to conceal the raw sheet metal edge 74.

In the preferred embodiment, the retainer member 500 is a one-piece, seamless and continuous part constructed from steel. The retainer member 500 is preferably welded to the body side panel 58 before the motor vehicle 10 is painted. By attaching the retainer member 500 a motor vehicle 10, a customer may initially purchase a hard top 14, and at any later date add a soft top 12 without the necessity of adding any body side retainers for properly retaining the soft top 12.

VI. Apparatus for Latching the Hard Top or the Soft Top to the Motor Vehicle

With specific reference to FIGS. 11–13, an apparatus 600 for latching the hard top 14 or the soft top 12 to the motor vehicle 10 (e.g., a latching arrangement 600) of the present invention will be described. The latching arrangement 600 as it relates to the soft top 12 is shown in FIG. 12 and as it relates to the hard top 14 in FIG. 13. The latching arrangement 600 includes a latching mechanism 602 for the soft top 12, a latching mechanism 604 for the hard top 14, and a horizontally elongated slot 606 located in an upper portion of the windshield frame 32. The slot 606 in the sheet metal of the windshield frame 32 is extruded and formed to present a rugged, durable attachment area.

As shown in FIGS. 12A and 12B, the latching mechanism 602 for the soft top 12 includes a pair of base plates 608 attached to the header 100, a manually displaceable handle 610 and a hook member 612. The handle 610 is pivotally attached to the base plates 608, which are attached to spaced apart portions of the header 100. In this regard, the handle 610 is pivotable about an axis defined by a pin 614 between a latched position (shown in solid lines in FIG. 12A) and an unlatched position (shown in broken lines in FIG. 12B).

The hook member 612 of the latching mechanism 602 for the soft top 12 is shown in FIG. 12B pivotally attached to the handle through a pin 616. The pivot axis for the hook member 612 defined by the pin 616 is offset from the pivot axis for the handle 610. When the handle 610 is in its latched position, the pivot axis for the hook member 612 is slightly above the pivot axis for the handle 610. As a result, an undercenter mechanical geometry (essentially an overcenter mechanical geometry with a reverse orientation) is established between the two pivot axes.

In latching the soft top 12 to the windshield frame 32, the handle 610 is rotated downward to its latched position, and the hook member 612 is engaged with the horizontally elongated slot 606. Such downward rotation of the handle

11

member 610 draws the hook member 612 upward to engage the slot 606. The handle 610 provides a lever arm for creating the necessary force to actuate the hook member 612 and further provides a mechanical advantage to draw the hook member 612 into the elongated slot 606 and compress a header seal (not shown) located on the top of the windshield frame 32. The header seal and the fabric of the soft top 12 provide a resistance force for keeping the latching mechanism 602 in tension such that the undercenter orientation retains the latch mechanism 602 closed and secure.

Turning to FIG. 13, the latching mechanism 604 for the hard top 14 is illustrated in its latched position. The hook member 612 and handle 610 of the hard top latching mechanism 604 are identical in construction and function to corresponding elements of the soft top latching mechanism 602. The base plates 618 of the hard top latching mechanism 604 similarly function to pivotally interconnect the handle with the top header 100 and are the only components not identical between the latching mechanisms 602 and 604.

VII. Motor Vehicle Top System in which the Hard Top may be Operatively Installed over the Folded Soft Top

As noted above, the top system of the present invention allows the hard top 14 to be operatively installed over the folded soft top 12. One purpose of this feature is to allow delivery of both tops 12 and 14 to the customer. Another purpose is to allow for an expanded range of uses of the vehicle 10. The owner/user can have the hard top 14 on for greater comfort and less noise on long trips and on arrival, take the hard top 14 off and have the soft top 12 for local use with the benefit of open air driving. The soft top 12 is ready to be moved to its operative position or retained in the stored position for available protection from the element from adverse weather conditions.

The ability of the top system to allow the hard top 14 to be operatively installed over the folded soft top 12 is made possible largely in part due to the several unique aspects of the present invention described above. For example, the soft top 12 folds back and is contained within the boundaries of the body side 18 and the tailgate area while having a low stack height. Additionally, the retainer members 500 welded onto the body side section 58 allow the tops 12 and 14 to function interchangeably. As noted above, the captured nuts 509 carried in the retainer members 500 allow the hard top fasteners 78 to be easily accessible and installed even with the support bows 102-106 of the soft top 12 down in that area (as shown in FIG. 6). These features discussed above combine to allow the soft top 12 to fit under the hard top 14. In addition, a lower rear portion (not specifically shown) of the hard top side section is configured with a clearance on each side to allow the soft top 12 to fit under the hard top 14.

VIII. Method of Installing the Soft Top

Installation of the soft top 12 utilizing the features of the present invention provides an improved method of tensioning the fabric of the soft top 12. The preferred method, which is illustrated throughout the drawings, includes the following general steps:

1. Articulating the soft top 12 from its stored position to its operative position (as shown in FIG. 8).
2. Engaging the latching mechanism 602 carried by the forward edge 50 of the soft top 12 with the windshield slot 606 by moving the handle 610 from the upper (unlatched) position to the lower (latched) position (as shown in FIG. 12A).

12

3. Zipping the rear window 48 in the rear panel 40 and the quarter windows 42 in the side sections 38 (as shown in FIG. 18).

4. Tucking in the retainers 400 into the horizontally oriented molded-in channels 244 of the removable door frame assembly 200 (as shown in FIG. 14).

5. Tucking the forward retainer 62 attached to the side section 38 of the soft top 12 into the vertically oriented molded-in channels 246 of the removable door frame assembly 200 (as shown in FIG. 15).

6. Tucking the retainer 80 of the side section 38 of the soft top 12 into the slot 512 defined by the welded-on retainer 500 on top of the body side panel 58, working from the front to the rear. As these retainers 80 are tucked in, the soft top 12 is gradually tensioned against the flexing of the L-shaped members 116.

7. Finally, rear corner retainers 84 in the soft top cover 12 are tucked in, effectively completing the securement and tensioning of the soft top

12. The fabric stretched over the bows provides the soft top's total tension (as shown in FIG. 19).

As noted above, the arrangement for articulating the soft top 12, especially the L-shaped members 116 connected to the #3 bow 104, provides a spring load which serves as a counter-force to the fabric. Thus, the method for attaching the soft top effectively employs a spring load in the bow assembly structure and the fabric of the soft top 12 without separate tensioning devices.

While the above description constitutes the preferred embodiment of the present invention, it will be appreciated that the invention is susceptible to modification, variation, and change without departing from the proper scope or fair meaning of the present invention. In this regard, while the various features of the present invention have been shown and described in connection with a specific motor vehicle, it will be appreciated by those skilled in that art that many of these features are suitable in connection with motor vehicles.

We claim:

1. An arrangement for attaching a soft top having a transverse edge to a motor vehicle having a body, the body defining an opening, the arrangement comprising:

a retainer element including a first portion and a second portion, the first portion fixedly attached to the transverse edge of the soft top; and

a structural element interconnected to the vehicle body, the structural element defining a channel for operatively receiving the second portion and retaining the soft top in a transverse direction;

wherein the first portion of the retainer is oriented substantially horizontal and laterally extends beyond the structural element so that rain and condensation are shed laterally away the opening in the body.

2. The arrangement for attaching a soft top to a motor vehicle of claim 1, wherein the second portion is disposed at an angle relative to the first flange.

3. The arrangement for attaching a soft top to a motor vehicle of claim 2, wherein the channel opens in a generally downward direction for receiving the retainer.

4. The arrangement for attaching a soft top to a motor vehicle of claim 3, wherein the structural member is a door frame.

5. The arrangement for attaching a soft top to a motor vehicle of claim 2, wherein the first portion is disposed at an obtuse angle relative to the second portion.

6. The apparatus for attaching a soft top to a motor vehicle of claim 1, wherein the second portion is interconnected to

13

the first portion through an intermediate portion, the first portion, second portion and intermediate portion defining a trough extending in a longitudinal direction.

7. The apparatus for attaching a soft top to a motor vehicle of claim 6, wherein the soft top is fixedly attached to the intermediate portion and the first portion.

8. A top system for a motor vehicle in combination with the motor vehicle, the motor vehicle including a body defining a door opening, the top system including:

a fabric soft top having a top section with a pair of laterally spaced apart edges;

a door frame attached to the motor vehicle, the door frame defining a molded-in channel; and

a retainer element interconnecting the door frame and the fabric soft top, the retainer element including a first portion fixedly attached to one of the laterally spaced apart edges of the fabric soft top above the door opening and a second portion retained by an interference fit within the molded-in recess of the door frame, the first portion extending laterally beyond the door frame a substantial distance;

whereby the top system functions to shed rain and condensation laterally away from the door opening.

9. The top system for a motor vehicle of claim 8, wherein the first portion laterally extends beyond the door frame.

10. The top system for a motor vehicle of claim 9, wherein the first portion comprises a first flange.

11. The top system for a motor vehicle of claim 10, wherein the second portion comprises a second flange disposed at an angle relative to the first flange.

12. The top system for a motor vehicle of claim 11, wherein the second flange is disposed at an obtuse angle relative to the first flange.

13. The top system for a motor vehicle of claim 8, wherein the retainer element includes an intermediate portion interconnecting the first portion and the second portion, the retainer element defining a trough extending in a longitudinal direction.

14

14. The top system for a motor vehicle of claim 8, wherein the first portion is oriented substantially horizontal.

15. A top system for a motor vehicle in combination with the motor vehicle, the motor vehicle including a body defining a door opening, the top system including:

a fabric soft top having a top section with a pair of laterally spaced apart edges;

a door frame attached to the motor vehicle, the door frame defining a molded-in channel; and

a retainer element interconnecting the door frame and the fabric soft top, the retainer element including a first portion fixedly attached to one of the laterally spaced apart edges of the fabric soft top above the door opening and a second portion retained by an interference fit within the molded-in recess of the door frame, the first portion oriented substantially horizontal and extending laterally beyond the door frame a substantial distance;

whereby the retainer element operates in cooperation with the soft top to shed rain and condensation away from the door opening.

16. The top system for a motor vehicle of claim 15, wherein the retainer element includes an intermediate portion interconnecting the first portion and the second portion, the first portion and the second portion disposed at angles relative to the intermediate portion and cooperating with the intermediate portion to define a trough extending in a longitudinal direction.

17. The top system for a motor vehicle of claim 16, wherein the one of the laterally spaced apart edges is securely attached to the first portion and the intermediate portion.

* * * * *