

(19)
(12)

(KR)
(B1)

(51) 。 Int. Cl.⁶
H02P 6/00

(45)
(11)
(24)

2004 04 14
10-0404782
2003 10 28

(21) 10-1996-0029093
(22) 1996 07 19

(65)
(43)

10-1997-0008821
1997 02 24

(30) 95-183824 1995 07 20 (JP)

(73) 가 가 가 4-6

(72) 가 10-6

2196-65

가 2-29-1

(74)

:

(54)

U VP 가 W , OA 가 V , UP WN 가 가 .

3

1 1
2 1
3 1

가, OA 가 ,가
 , OA 가 ,가 (, HDD)
)가 , HDD ()
 1 5-161387 , 120- 180 0, 180- 30
 0 , 300 360 0 , 0 0- 120 , 3 가
 , 5-137384 , 3 가
 120 , NEC Res. amp; Develop., Vol. 32, No. 3, pp. 368-378, July 1991 3 (PWM)
 , HDD 가 , 6 n MOSFET
 3 , 3 PWM , PWM duty 가
 PWM , , 3
 , 100kHz
 PWM duty가 , PWM 가 PW
 , 3 (U, V, W) U 가 , V V
 M , , U V , V
 PWM (). 120 가
 , 5-161387 120 0
 , , L · di/dt(L : , di/dt :)
 , 가 PWM 가 , 가
 가 가 , 가 , 가
 가 , 가 , 가
 120 加藤- 「 IC」 pp. 57 3
 , 5-137384 120 , 5-161387 가 ,
 , 120 180 가 ,
 , 120
 3 (8 13) 2 (10, 11) 1 2 (25, 26)
 , 2 (10, 11) 1 (25)
 3 (27, 28) 2 (28)
 1 (23, 24) 1 (23)

2 (10, 11) 1 (25)
 3 (27, 28) 2 (28)
 가 , 1 (23, 24) 1
 2 가 (23, 24) , 2 가 (10, 11) 1 (25)
 가 , 1 (23, 24) 1 (23)
 , 1 1 7 1 (1) 3 3 1
 U , (2) (1) V
 , (3)
 PWM W , (4) U
 , (5) V , (6) W
 (1) (2) 가 (, r
 (1)) ,
 , 1 , PWM 1 4가
 1) U , W ,
 2) U , W ,
 3) U , W ,
 4) U , W ,
 , V , W V
 (V상 출력전류)=(W상 출력전류)-(U상 출력전류) 【식 1】
 [1] W 가 , U V
 가 , U 4가
 2) , U U
 U , V 가
 1 3.5 , (100) , (7) , (8) (13)
 2 , 2 , (14) , (15)
 (16) 1 , (17)
 , (18) (17) , (1)
 9) , (20) , (21) (19)
 , (15) 가 , (22)
 , (8) (13) , 가 (14)
 , (100) () 가 (101)
 , , (8) (13) ,
 ET , V W 3 3 MOSF
 MOSFET , (24), (26), (28) N MOSFET , (29) P
 , (30) , (31) , (32) , (33) MOSFET , (34) , (35) PWM
 , (36) PWM , (37) V Iv, (38) Iv', (39) ()
 , P MOS 가 가 3 4
 . PWM 가 가 (35) . 3 (34)가 , PWM (36)
 (28) (35) ()가 , (29)
 (30) Vref(31) , (32) (33) (28) , ()
 34)가 (PWM (36) (35) , 가 가
 () (39)가 가 , 가 가
 , U V 가 가 U 가

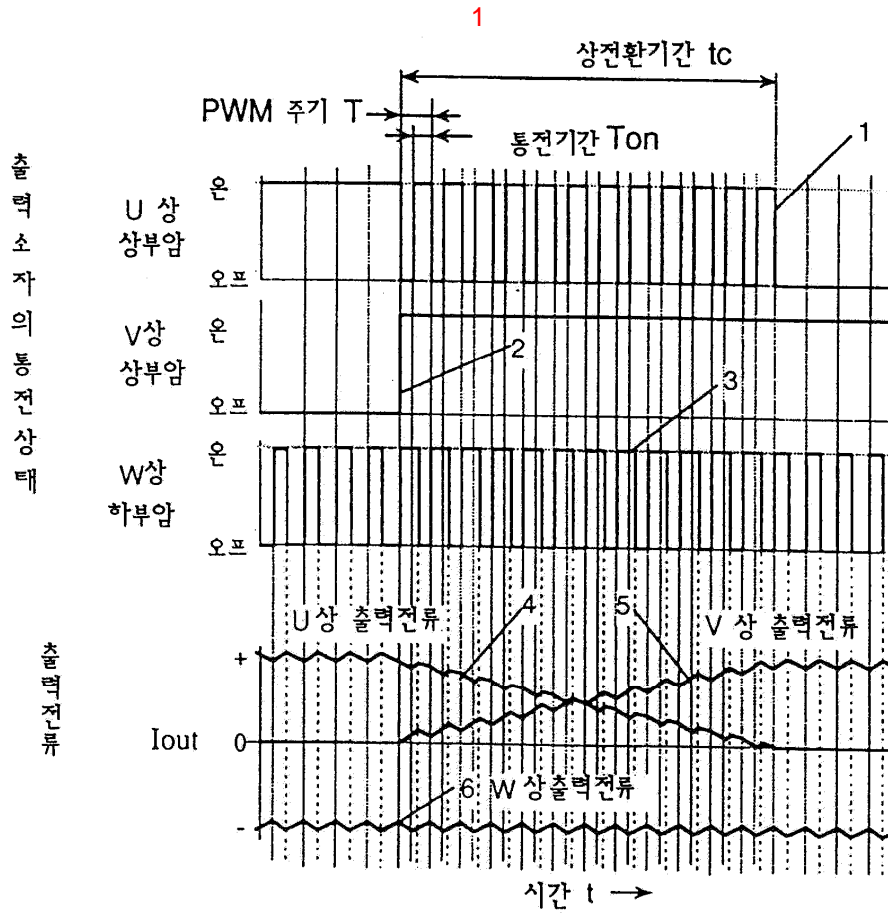

2

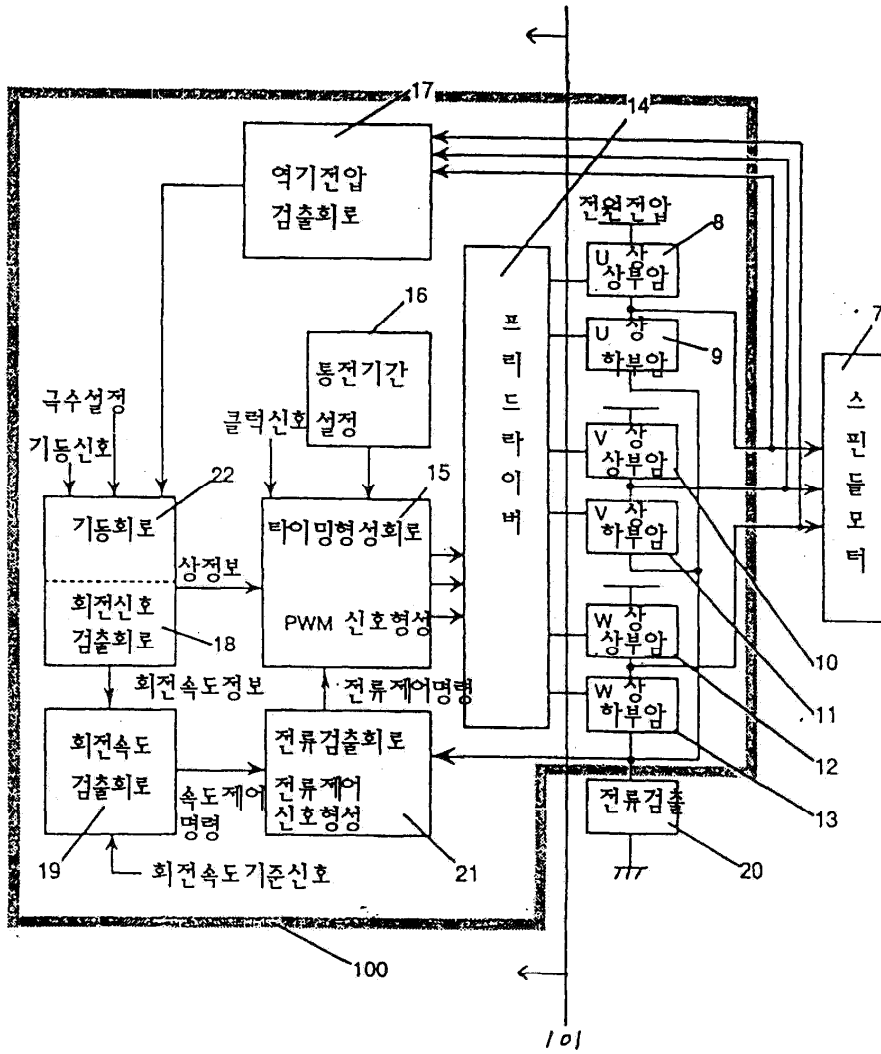

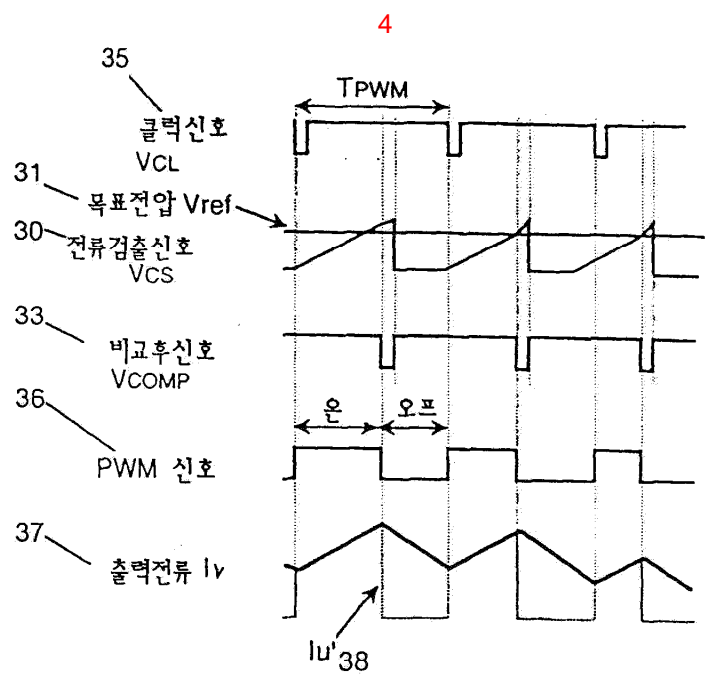
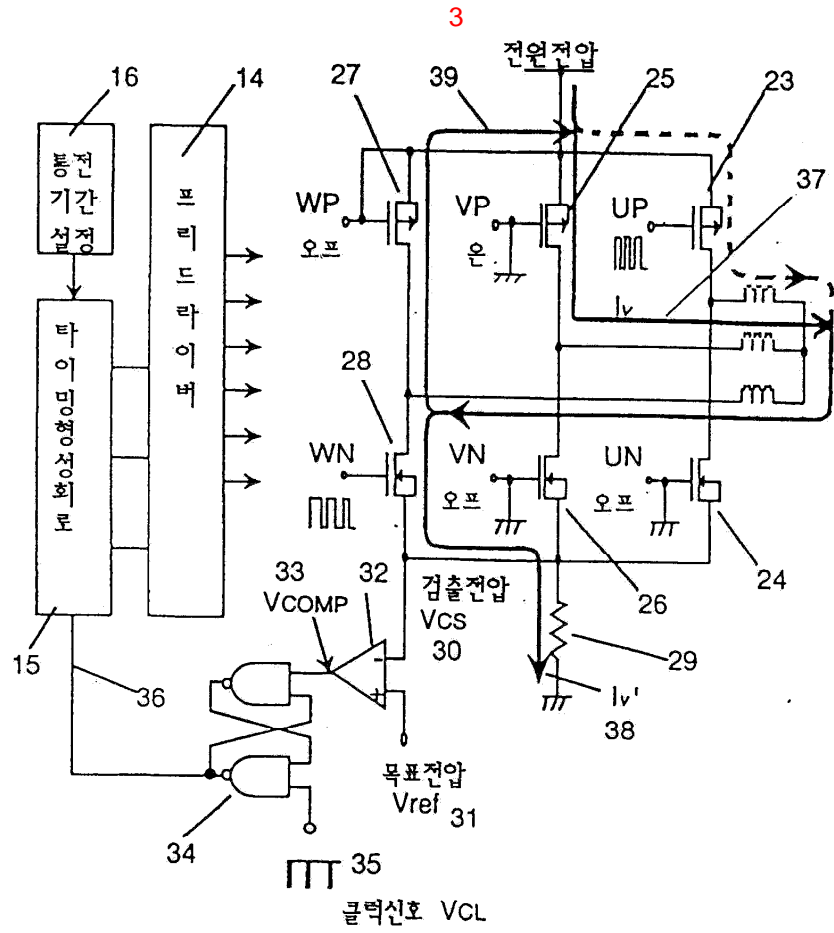

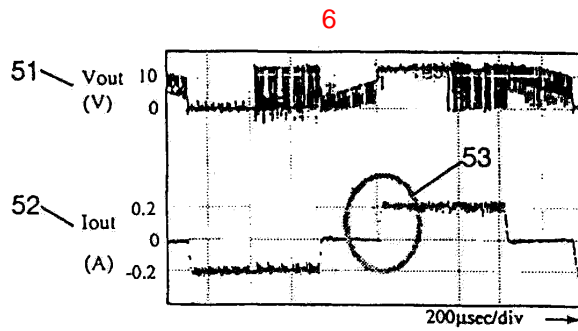
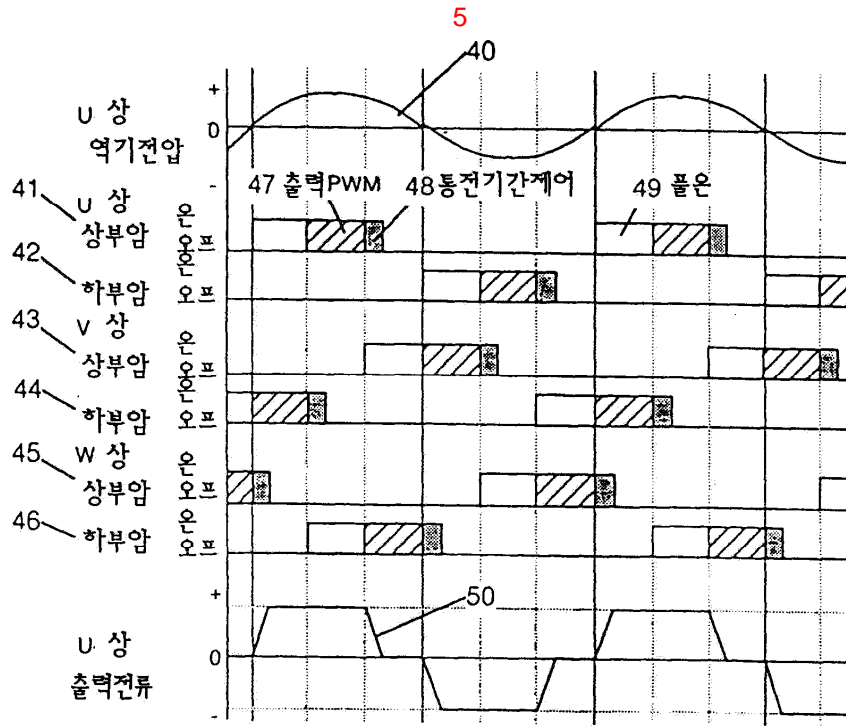

(a) 구형파 PWM

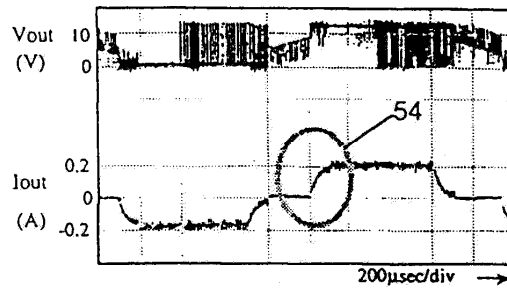

(b) 75 % duty

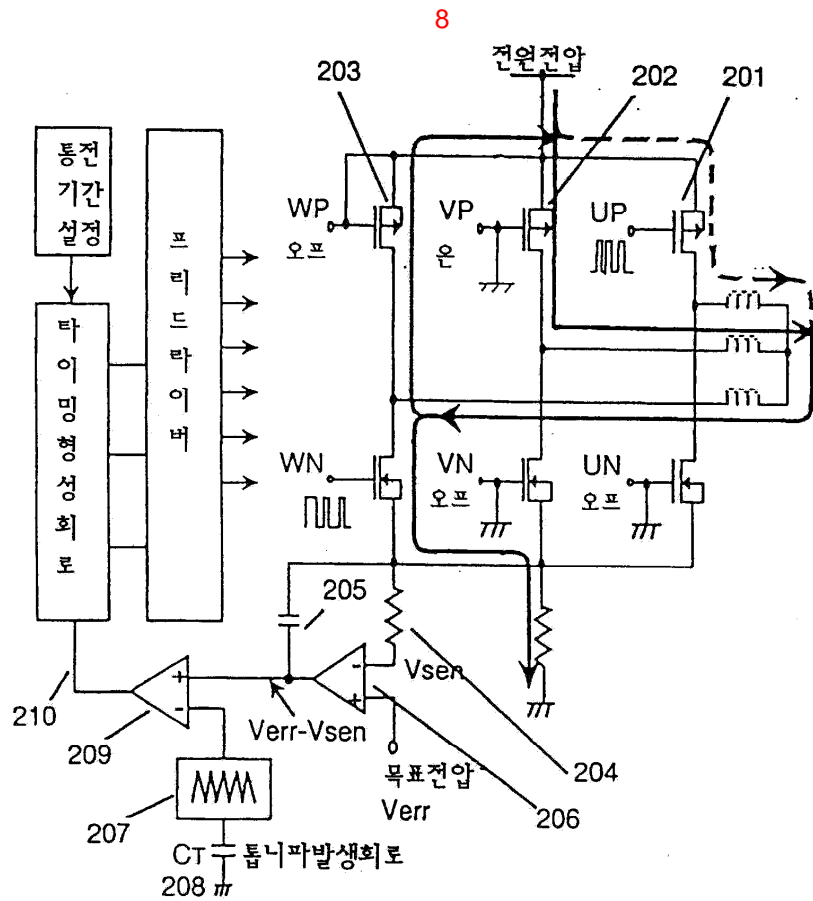
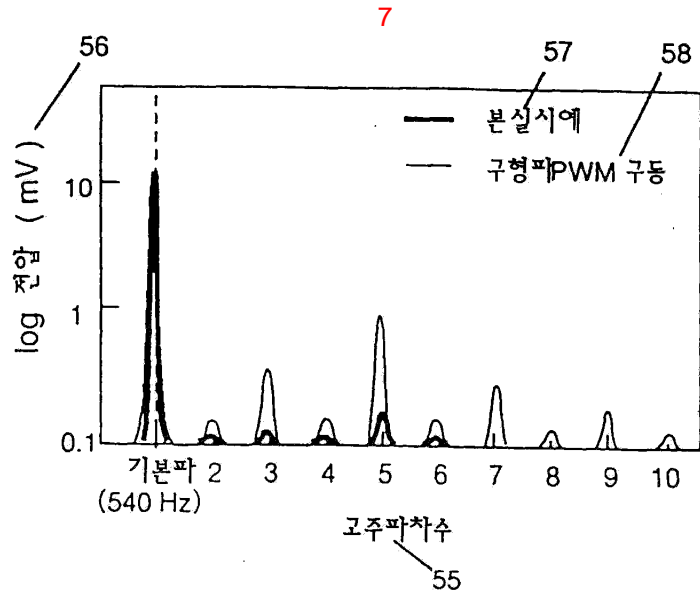

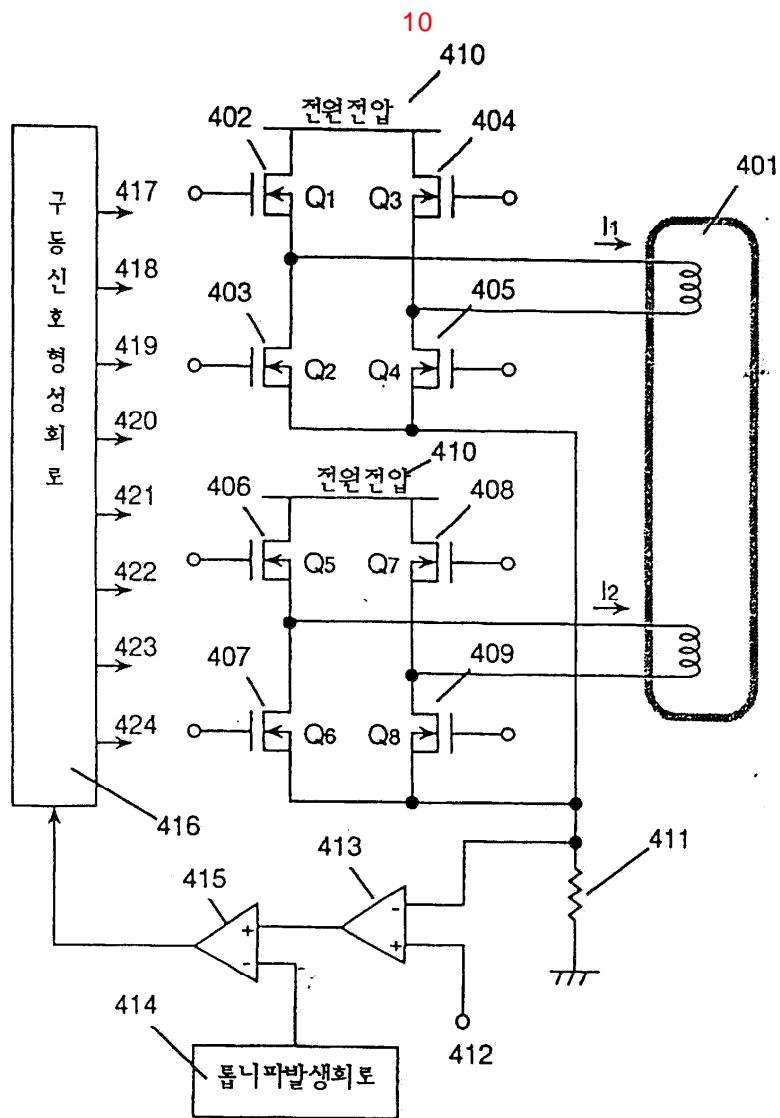
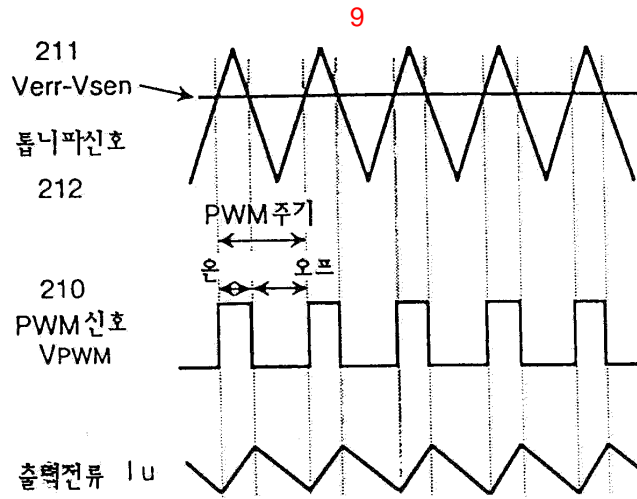

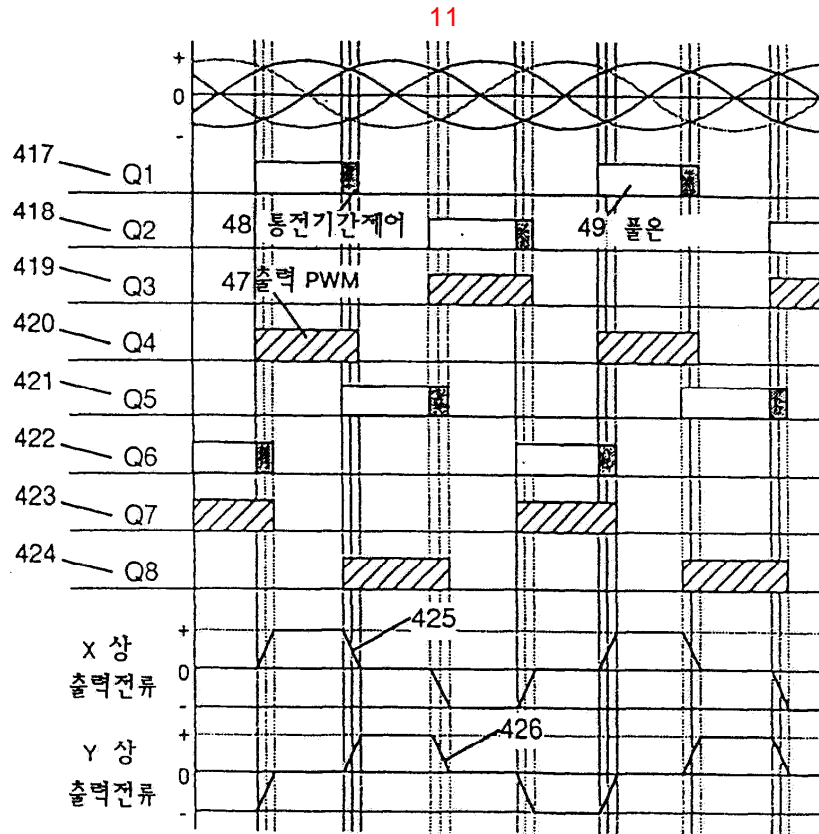

(a) 상면도

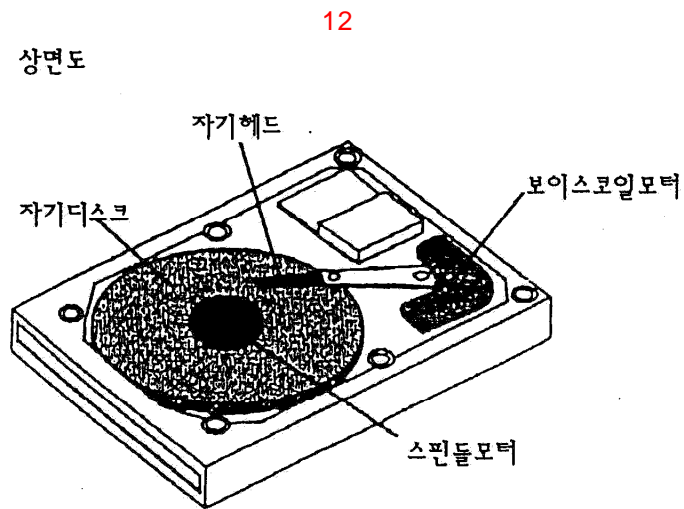

(b) 하면도

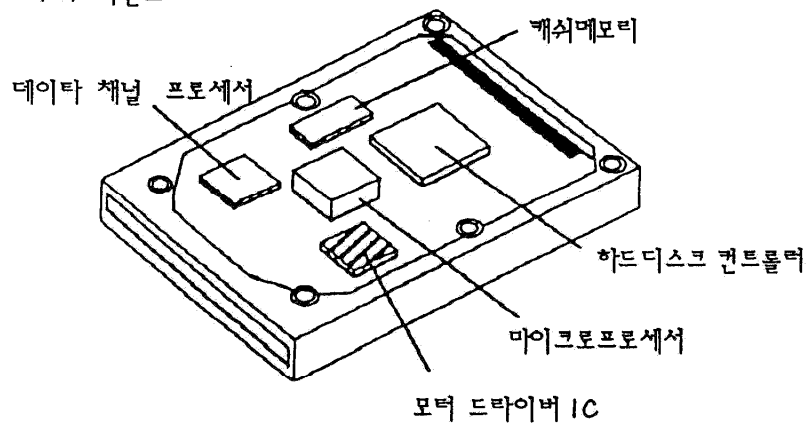

13

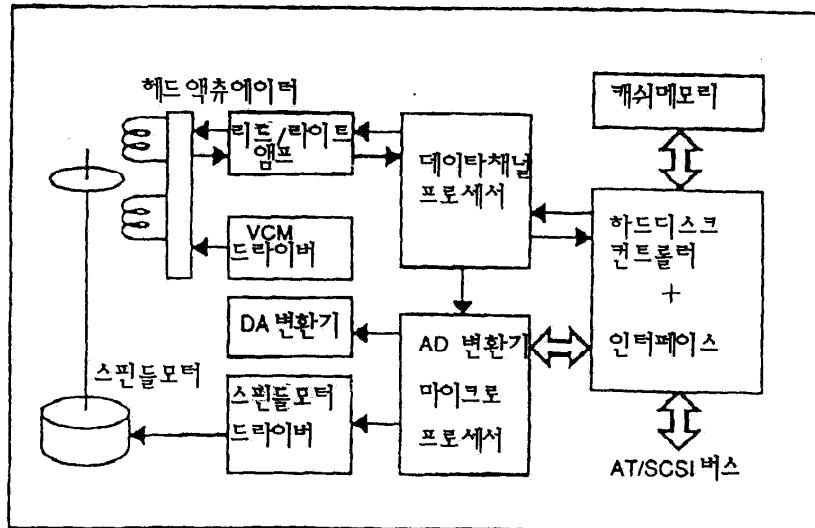

14

