



(11) **EP 1 566 900 B1**

(12) **EUROPEAN PATENT SPECIFICATION**

(45) Date of publication and mention of the grant of the patent:
26.05.2010 Bulletin 2010/21

(51) Int Cl.:
H04B 7/26^(2006.01) H04B 7/15^(2006.01)

(21) Application number: **05250933.8**

(22) Date of filing: **18.02.2005**

(54) **Wireless relay system, apparatus and method**

Anordnung, Gerät und Verfahren für drahtloses Relais

Système, appareil et méthode de relais sans fil

(84) Designated Contracting States:
DE GB

(30) Priority: **19.02.2004 JP 2004042789**

(43) Date of publication of application:
24.08.2005 Bulletin 2005/34

(73) Proprietor: **NTT DoCoMo, Inc.**
Tokyo 100-6150 (JP)

(72) Inventors:

- **Fujii, Hiromasa,**
Int. Prop. Dpt.,
NTT DoCoMo Inc.
Chiyoda-ku,
Tokyo 100-6150 (JP)
- **Suda, Hirohito,**
Int. Prop. Dpt.,
NTT DoCoMo Inc.
Chiyoda-ku,
Tokyo 100-6150 (JP)

- **Tanaka, Tetsu,**
Int. Prop. Dpt.,
NTT DoCoMo Inc.
Chiyoda-ku,
Tokyo 100-6150 (JP)

(74) Representative: **Maury, Richard Philip**
Marks & Clerk LLP
90 Long Acre
London
WC2E 9RA (GB)

(56) References cited:
EP-A- 0 851 606 EP-A1- 1 087 559
WO-A-2004/001986 US-A- 5 115 514
US-A- 6 061 548 US-A1- 2002 039 383
US-A1- 2003 124 976 US-B1- 6 377 612

EP 1 566 900 B1

Note: Within nine months of the publication of the mention of the grant of the European patent in the European Patent Bulletin, any person may give notice to the European Patent Office of opposition to that patent, in accordance with the Implementing Regulations. Notice of opposition shall not be deemed to have been filed until the opposition fee has been paid. (Art. 99(1) European Patent Convention).

Description**BACKGROUND OF THE INVENTION**

5 1. Field of the Invention

[0001] The present invention generally relates to a wireless relay system, a wireless relay apparatus, and a wireless relay method for wireless communication between a transmission apparatus and a reception apparatus via a single or a plurality of wireless relay apparatuses.

10

2. Description of the Related Art

[0002] Recently and continuing, a method of executing relay between a transmission apparatus and a reception apparatus by using the same frequency band with a wireless relay apparatus (=relay device) is being considered. In employing the wireless relay apparatus, it is important to control oscillation created by a coupling loop interference wave from a transmitter antenna to a receiver antenna. That is, a characteristic degraded by generation of oscillation is a problem.

15

[0003] Furthermore, since the relay is considered as a method that is mainly employed for broadcasting, controlling the coupling loop interference wave is relatively easy. Meanwhile, in a case where the wireless relay apparatus is situated in the same environment (not a steel tower or on top of a building) as a typical mobile terminal, such as in a mobile communication system, changes of channel of the coupling loop interference wave become more frequent in accordance with movement of the wireless relay apparatus or changes of the surrounding environment. There is a problem in which a highly advanced technology of canceling the coupling loop interference wave is required for swiftly corresponding to abrupt changes of the coupling loop interference wave.

20

[0004] In order to solve the problems of the conventional wireless relay apparatus, various methods are proposed.

25

[0005] For example, a method of canceling the coupling loop interference wave, which uses a pilot signal inserted by a transmitter apparatus, is proposed (See, for example, Japanese Laid-Open Patent Application Nos.2003-174392 and 2003-298548). Japanese Laid-Open Patent Application No.2003-174392 focuses on amplitude and phase being inserted into a predetermined pilot signal beforehand, in which an error signal is obtained by detecting frequency characteristics throughout the entire signal band by using the pilot signal, multipath components of transmission signals from a master station and other relay stations and a replica signal of the coupling loop interference wave are generated, and the replica signal is subtracted from the reception signal. Accordingly, even in a propagation environment where a large number of coupling loop interference waves exist or even in a propagation environment where multipath components of the main station transmission signal exist, the influences of both the coupling loop interference waves and the multipath components of the master station transmission signal can be eliminated.

30

35

[0006] According to Japanese Laid-Open Patent Application No.2003-298548, a subtractor for subtracting duplications of coupling loop interference signals from input signals, an FIR filter for generating duplications of coupling loop interference signals, and a filter coefficient generation part for generating an FIR filter from the output of the subtractor are provided. The filter coefficient generation part performs a hard decision and remodulates a data carrier, calculates a transmission path characteristic by referring to the re-modulated data carrier, calculates cancellation residue from the transmission path characteristic, and updates the coefficient of the FIR filter based on the results of applying IFFT to the cancellation residue. Accordingly, a coupling loop canceller enables tracking performance to be improved and cancelable delay time to be expanded.

40

[0007] A configuration of a conventional wireless relay apparatus, which uses a coupling loop cancellation method by using a pilot signal inserted by a transmitter apparatus, is described below.

45

[0008] Fig. 15 is block diagram showing a configuration of a conventional wireless relay apparatus. As shown in Fig. 15, the wireless relay apparatus includes a subtractor 201 for subtracting a replica of a coupling loop interference signal from an input signal, an FIR filter 202 for generating the replica of the coupling loop interference signal, a coefficient update part 203 for generating a coefficient of the FIR filter 202, a pilot signal generation part 204 for generating a pilot signal with an amplitude and phase that are predefined, and an amplifier 205.

50

[0009] In the conventional wireless relay apparatus, the coefficient update part 203 obtains a characteristic of a transmission path, calculates a cancellation residue from the characteristic of the transmission path, and updates the coefficient of the FIR filter 202. Accordingly, tracking performance can be improved and cancelable delay time can be expanded.

55

[0010] As for other methods, there are a method of estimating a coupling loop interference by adding a pilot signal (a relatively long PN sequence with low electric power) to a relay signal of a wireless relay apparatus (see, for example, Japanese Laid-Open Patent Application No.2001-186073); a method of estimating a coupling loop interference wave by transmitting a pilot signal from a wireless relay apparatus with a different frequency band (see, for example, Japanese

Laid-Open Patent Application No.8-331016); and a method of estimating a coupling loop interference wave by temporarily stopping relay (see, for example, Japanese Laid-Open Patent Application No. 2000-244382) .

[0011] However, the coupling loop cancellation method disclosed in Japanese Laid-Open Patent Application No. 2003-174392 has a problem of increasing noise in the receiver.

[0012] In the coupling loop cancellation method disclosed in Japanese Laid-Open Patent Application No.2003-298548, a part of noise voltage of a sub-carrier will be excessively amplified and transmitted since a transmission signal is amplified stronger as the signal received by a wireless relay apparatus becomes weaker. Accordingly, the bit error rate tends to increase.

[0013] Furthermore, the coupling loop cancellation method disclosed in Japanese Laid-Open Patent Application No. 2001-186073 has a problem of increasing the error rate in the receiver apparatus by applying a disturbance to a signal that is to be originally transmitted.

[0014] Furthermore, in the coupling loop cancellation method disclosed in Japanese Laid-Open Patent Application No.8-331016, since the estimated channel value relies on a frequency that is used, accuracy in estimating the channel of the coupling loop is liable to deteriorate, and reparation of a frequency band for estimating the coupling loop interference wave would be necessary.

[0015] Furthermore, in the coupling loop cancellation method disclosed in Japanese Laid-Open Patent Application No.2000-244382, there is a problem that communication between a transmitter apparatus and a receiver apparatus is temporarily interrupted at a timing unexpected by the transmitted apparatus.

[0016] EP-A-0851606 discloses a system as defined in the pre-characterising portion of claim 1.

[0017] The invention provides a relay system, relay apparatus and relay method as defined in claims 1, 11 and 12.

[0018] The present invention can substantially overcome one or more of the problems caused by the limitations and disadvantages of the related art.

[0019] Features and advantages of the present invention are set form in the description which follows, and in part will become apparent from the description and the accompanying drawings, or may be learned by practice of the invention according to the teachings provided in the description. Objects as well as other features and advantages of the present invention will be realized and attained by a wireless relay system, a wireless relay apparatus, and a wireless relay method particularly pointed out in the specification in such full, clear, concise, and exact terms as to enable a person having ordinary skill in the art to practice the invention.

[0020] In the wireless relay system according to an embodiment of the present invention, the first wireless station may include a control signal transmission part for transmitting a control signal that is included in the transmission symbols transmitted to the wireless relay apparatus, wherein the wireless relay apparatus includes a relay refrain control part for refraining from relaying the radio signals in a section of the control signal.

[0021] In the wireless relay system according to an embodiment of the present invention, the control signal transmission part may include a frame generation part for generating a frame of the transmission symbols with a null symbol inserted therein, wherein the relay refraining control part includes a relay refraining part for refraining relay of signals in a section where the null signal is inserted.

[0022] In the wireless relay system according to an embodiment of the present invention, the wireless relay apparatus may include a delay part for delaying the relay of the transmission symbols to an extent of N symbols, wherein N represents an integer which is not less than 1.

[0023] In the wireless relay system according to an embodiment of the present invention, in a case of relaying a signal by using an OFDM transmission method, the wireless relay apparatus may include an IFFT part for performing an IFFT process to generate the transmission signal, and an FFT part for performing an FFT process on the reception signal, and the first wireless station includes an OFDM frame generation part for inserting a null signal into a portion of a time/frequency domain and generating a frame that is to be transmitted to the wireless relay apparatus.

[0024] In the wireless relay system according to an embodiment of the present invention, the OFDM frame generation part may calculate a sub-carrier interval for inserting the the null signal in accordance with a formula of $\text{ceil} \{ (\text{FFT point value}) / (\text{GI point value}) \}$, wherein "ceil (x)" represents a numeric function that returns a least integer greater than x, "FFT" represents Fast Fourier Transform and "GI" represents guard interval.

[0025] In the wireless relay system according to an embodiment of the present invention, the wireless relay apparatus may include a channel estimation part for receiving the pilot signal and estimating a channel in accordance with the received pilot signal, and a signal amplitude control part for controlling an amplitude of the reception signal based on a result of the channel estimation by the channel estimation part.

[0026] In the wireless relay system according to an embodiment of the present invention, the signal amplitude control part may employ a water filling theorem for controlling the amplitude of the reception signal.

[0027] In the wireless relay system according to an embodiment of the present invention, the first wireless station, the second wireless station, and the wireless relay apparatus each may include a plurality of antennas, wherein the antennas are used to form a MIMO channel, wherein the relay control part, a pilot signal transmission part, the coupling loop interference wave estimation part, and the coupling loop interference wave cancelation part are employed when executing

transmission of MIMO channel signals.

[0028] Other objects and further features of the present invention will be apparent from the following detailed description when read in conjunction with the accompanying drawings.

5 **BRIEF DESCRIPTION OF THE DRAWINGS**

[0029]

10 Fig. 1 is drawing showing an exemplary configuration of a wireless relay system including a wireless relay apparatus according to a first embodiment of the present invention;

Fig. 2 is a drawing showing an exemplary configuration of the wireless relay apparatus shown in Fig. 1;

Fig. 3A is a drawing showing an exemplary configuration of a conventional transmission apparatus;

Fig. 3B is a drawing showing an exemplary configuration of a transmission apparatus according to an embodiment of the present invention;

15 Fig. 4 is a drawing showing an exemplary configuration of a transmission frame according to a first embodiment of the present invention;

Fig. 5 is a drawing showing an exemplary configuration of a wireless relay apparatus according to a second embodiment of the present invention;

20 Fig. 6 is a drawing showing an exemplary configuration of a transmission frame according to a second embodiment of the present invention;

Fig. 7 is a drawing showing an exemplary configuration of a wireless relay apparatus according to a third embodiment of the present invention;

Fig. 8 is a sequence diagram for describing control of insertion of null signals according to a fourth embodiment of the present invention;

25 Fig. 9 is a drawing showing an exemplary configuration of a transmission apparatus according to a fourth embodiment of the present invention;

Fig. 10 is a drawing showing an exemplary configuration of a wireless relay apparatus according to a fifth embodiment of the present invention;

30 Figs. 11A-11B are drawings showing for describing delay operation according to a two symbol delay element according to a fifth embodiment of the present invention;

Fig. 12 is a drawing showing an exemplary configuration of a conventional multi-point relay transmission system according to an MIMO channel signal transmission method;

Fig. 13 is a drawing showing an exemplary configuration of a wireless relay apparatus used in an MIMO channel configuration;

35 Fig. 14 is a drawing showing an exemplary configuration of a coupling loop interference suppression part of the wireless relay apparatus shown in Fig. 13; and

Fig. 15 is a drawing showing an exemplary configuration of a conventional wireless relay apparatus.

40 **DESCRIPTION OF THE PREFERRED EMBODIMENTS**

[0030] In the following, embodiments of the present invention are described with reference to the accompanying drawings.

(First Embodiment)

45 **[0031]** An example of a wireless relay system according to a first embodiment of the present invention is shown in Fig. 1. In Fig. 1, the wireless relay system includes a transmission apparatus 1, a wireless relay apparatus 2, and a reception apparatus 3.

50 **[0032]** The transmission apparatus 1 and the reception apparatus 3 in the first embodiment of the present invention are described below by assuming that the relation between the transmission apparatus 1 and the reception apparatus 3 is a relation of a base station (transmission apparatus 1) and a mobile station (reception apparatus 3).

[0033] The signals received by the reception apparatus 3 include a signal directly received from the transmission apparatus 1 and a signal received via the wireless relay apparatus 2. A signal transmitted from the transmission apparatus 1 is first received in the wireless relay apparatus 2, and is retransmitted to the reception apparatus 3 at the same frequency. Furthermore, the wireless relay system of the first embodiment of the present invention is a system in which signal relay is executed according to a single carrier transmission method or a multicarrier transmission method (e.g. OFDM transmission method).

[0034] Fig. 2 is a drawing showing an exemplary configuration of the wireless relay apparatus 2 shown in Fig. 1.

[0035] In Fig.2, the wireless relay apparatus 2 includes a reception antenna 11, a reception part 12, a subtractor 13, an FIR filter 14, a coefficient determination part 15, a pilot signal generation part 16, a pilot insertion timing detection part 17, a switch circuit 18, an amplifier 19, and a transmission antenna 20.

[0036] In the transmission apparatus 1 shown in Fig.1 according to the first embodiment of the present invention, a null signal(s) is inserted into a transmission frame. First, this insertion of the null signal is described with reference to Figs.3A, 3B and 4. Fig.3A is a drawing showing an exemplary configuration of a conventional transmission apparatus, Fig.3B is a drawing showing an exemplary configuration of a transmission apparatus 1 of the present invention, and Fig. 4 is a drawing showing an exemplary configuration of a transmission frame according to the first embodiment of the present invention.

[0037] As shown in Fig. 3A, the conventional transmission apparatus includes a data symbol generation part 21 for receiving input of information bits and generating a data symbol, a pilot signal generation part 22 for generating a pilot signal, and a frame generation part 23 for generating a transmission frame. The frame generation part 23 forms the transmission frame by multiplexing the data symbol output from the data symbol generation part 21 and the pilot signal output from the pilot signal generation part 22.

[0038] Meanwhile, although the transmission apparatus 1 according to the first embodiment of the present invention has a basic configuration similar to that of the conventional transmission apparatus, as shown in Figs.3A and 3B, the transmission apparatus 1 executes a different frame generation process at a frame generation part 33. That is, the frame generation part 33 according to the first embodiment of the present invention inserts a null signal in a transmission frame, multiplexes the transmission frame with a null signal position signal that includes information regarding the position at which the null signal is inserted, and transmits the transmission frame (See Fig. 3B). The null signal position information includes, for example, the number of null signals, the time of null signals, or the interval of null signal insertion in a frequency direction.

[0039] Fig.4 is a drawing showing an exemplary configuration of a transmission frame generated by the frame generation part 33 in the above-described manner. As shown in Fig.4, the frame generation part 33 according to the first embodiment of the present invention inserts m null symbols (illustrated as an outlined white space) (for example, $m=1$) at intervals of N symbols (illustrated as a diagonal line space). A pilot signal is inserted in the section of the null signal by the wireless relay apparatus 2 (described in further detail below).

[0040] Although m null symbols are inserted between each N symbol section in the example of the first embodiment of the present invention, the value of m null symbols may be set in accordance with a desired accuracy for estimating the coupling loop interference wave. For example, in a case where high accuracy is desired for estimating the coupling loop interference wave, m is set with a large value. For example, in a case where m is set as $m>2$, channel estimation accuracy can be heightened by obtaining the average of the channel estimation value obtained from m pilot signals and the estimation value of each channel.

[0041] Furthermore, the value of the m null symbols is required to be set with a fixed value, but may alternatively be a value that is changed adaptively. For example, in a case where estimation accuracy of coupling loop interference wave is poor, bit error rate may increase even if reception power is secured in the reception apparatus 3; therefore, the value of m null symbols may be controlled in accordance with reception power in the reception apparatus 3 and the bit error rate. In this case, the transmission apparatus 1 changes the value of the m null symbols based on information indicative of reception power and bit error rate transmitted from the reception apparatus 3.

[0042] Furthermore, since a coupling loop interference wave is received in the wireless relay apparatus 2 in a case where accuracy for estimating the coupling loop interference wave is poor, decrease in estimation accuracy of the coupling loop interference wave channel can be detected by obtaining a correlation between a reception waveform of a received signal and a time waveform of a reception signal received in the wireless relay apparatus 2 at a previous predetermined time.

[0043] Meanwhile, although N may be set as the frame size, N can be set in accordance with fluctuation velocity of the coupling loop interference wave of the wireless relay apparatus 2 (fluctuation velocity in a case where fluctuation velocity of the coupling loop interference wave fluctuates in accordance with travel speed of the wireless relay apparatus and the transmission apparatus). For example, in this case, N may be set as $N < (\text{frame size})$, and m null symbols may be inserted in plural portions in a single frame.

[0044] In general, the fluctuation amount of the coupling loop interference wave is indicated by the difference of impulse response of the coupling loop interference wave between a time point t_1 and a time point $t_1 + \Delta t$. Therefore, by obtaining a difference of channel estimation value between the current and previous coupling loop interference wave with respect to the impulse signals, and using the squared sums of the obtained values as an index, the fluctuation velocity of the coupling loop interference wave can be estimated.

[0045] Accordingly, by allowing the wireless relay apparatus 2 to detect fluctuation velocity of the coupling loop interference wave and report the detection results to the transmission apparatus 1, the value of N can be adaptively variable in accordance with fluctuation velocity of the coupling loop interference wave.

[0046] Next, operation of the wireless relay apparatus 2 is described with reference to Fig.2. The wireless relay

apparatus 2 receives a relay signal transmitted from the transmission apparatus 1 at the reception part 12 via the reception antenna 11. The relay signal received at the reception part 12 is input to the pilot insertion timing detection part 17. The pilot insertion timing detection part 17 extracts the null signal position signal from the input relay signal and detects the insertion position of the null signal. The pilot insertion timing detection part 17 transmits the pilot signal generated at the pilot signal generation part 16 instead of a reception signal during the period where the null signal is inserted. In order to do so, the pilot insertion timing detection part 17 connects point c and b in the switch circuit 18 in the insertion section of the null signal.

[0047] A pilot signal is generated in the pilot signal generation part 16. The generated pilot signal is inserted within the period of the null signal and is input to the amplifier 19. Then, the amplifier 19 amplifies the pilot signal to a desired electric power value, and transmits the pilot signal via the transmission antenna 20.

[0048] Furthermore, at the same time of executing the above-described operation, the coefficient determination part 15 estimates the channel of the coupling loop interference wave (transmission path characteristic) that fluctuates in accordance with, for example, changes in the surrounding environment, by referring to the reception signal corresponding to the pilot signal, and determines the coefficient of the FIR filter indicating said channel, that is, the filter coefficient that can cancel the coupling loop interference wave. That is, the FIR filter 14 is set with a coefficient so that the transfer function thereof is the same as that of the coupling loop interference wave.

[0049] The subtractor 13 subtracts the coupling loop interference wave (replica of the coupling loop interference wave) generated by the FIR filter 14 from the reception signal, thereby canceling the coupling loop interference. Then, a switch junction b of the switch circuit 18 is switched on. The reception signal having the replica subtracted therefrom is input to the amplifier 19, is amplified to a desired power level, and is transmitted to the transmission antenna 20.

[0050] Since the wireless relay apparatus 2 according to the first embodiment of the present invention transmits a pilot signal at the section in which the null signal is inserted, and at the same time, estimates the channel of the coupling loop interference wave in accordance with the reception signal corresponding to the pilot signal, the wireless relay apparatus 2 is able to estimate the coupling loop interference wave without interrupting communications between the transmission apparatus 1 and the reception apparatus 3.

[0051] Furthermore, since the wireless relay apparatus 2 cancels the coupling loop interference wave by generating a pseudo coupling loop interference wave with the FIR filter 14 in accordance with the estimated coupling loop interference wave and subtracting the output of the FIR filter 14 (output pseudo coupling loop interference wave) from a signal received by the wireless relay apparatus 2 with the subtractor 13, the wireless relay apparatus 2 can prevent oscillation due to the coupling loop interference wave with high accuracy. Accordingly, increases in bit error rate of the relay signal can be prevented, and reception quality of the relay signal can be enhanced.

[0052] It is to be noted that, since the signals prior to the first null symbol cannot be subjected to cancellation of the coupling loop interference wave, the signals may be excluded from being relayed and may be used to serve as a preliminary notification to the wireless relay apparatus 2

(Second Embodiment)

[0053] In a system executing OFDM communication, all transmission signals in a predetermined time do not need to be inserted with null signals, but alternatively, a symbol(s), which only forms a part of a sub-carrier, may be made into a null signal(s).

[0054] Fig.5 is a drawing showing an exemplary configuration of a wireless relay apparatus according to a second embodiment of the present invention. Fig.6 is a drawing showing an exemplary configuration of a transmission frame generated by a transmission frame generation part of a transmission apparatus according to the second embodiment of the present invention.

[0055] The wireless relay apparatus shown in Fig.5 has a configuration similar to that of the wireless relay apparatus 2 according to the first embodiment of the present invention shown in Fig.2, but is also provided with an FFT part 51 for performing an FFT process on a reception signal(s), and an IFFT part 59 for performing an IFFT process on a transmission signal(s). The parts, which suppress loop interference, are provided to each of the sub-carriers 50₁-50_n. Here, points that are different from the first embodiment of the present invention are described in detail.

[0056] In Fig.5, the IFFT part 59 performs IFFT (Inverse Fast Fourier Transform) on plural symbol data and transforms the symbol data into time domain signals (OFDM transmission signals). Meanwhile, the FFT part 51 performs FFT (Fast Fourier Transform) on reception signals and transforms the reception signals into frequency domain signals (OFDM reception signals).

[0057] Next, a configuration of a transmission frame according to the second embodiment of the present invention is described with reference to Fig.6. Fig.6 illustrates OFDM signals, before being subjected to the IFFT process, which are arranged in time and frequency domain. In Fig.6, vertical axis shows frequency and vertical axis shows time. In Fig.6, the diagonal line spaces represent data or pilot symbols, and the outlined white spaces represent null symbols.

[0058] Here, the frequency interval of the sub-carriers is determined in accordance with, for example, a formula

described below:

$\text{ceil} \{ (\text{sub-carrier number}) / (\text{GI point number}) \},$

wherein "ceil (x)" represents a numeric function that returns a least integer greater than x, and "GI" represents guard interval.

[0059] In a case where the values of channel estimations in an interval of $\text{ceil}((\text{subcarrier number}) / (\text{GI point number}))$ are obtained, it is ideal to estimate the channels of all sub-carriers by interpolating these values. However, since channel estimation accuracy may deteriorate depending on the interpolation method, null signals may be suitably inserted in a shorter frequency interval.

[0060] Since null signals are included only in a portion of the symbols of the sub-carriers, the present invention can decrease the loss of throughput due to the null symbol insertion. Accordingly, such a system can attain the same advantages as those of the first embodiment of the present invention.

(Third Embodiment)

[0061] Although the second embodiment of the present invention is described supposing the same power amplification factor is allocated against all subcarriers, in a case where OFDM transmission is employed, a wireless relay apparatus according to a third embodiment of the present invention changes the electric power amplification factor of each sub-carrier for attaining a more satisfactory communications quality. That is, the wireless relay apparatus according to the third embodiment of the present invention has a function of controlling the electric power amplification factor of each sub-carrier.

[0062] As shown in Fig. 7, the wireless relay apparatus according to the third embodiment of the present invention has a configuration similar to that of the wireless relay apparatus 2 according to the second embodiment of the present invention shown in Fig. 5, but is also provided with a transmission apparatus insertion pilot signal generation part 62 which generates the same pilot signals inserted by the transmission apparatus, a channel estimation part 63, a power control amount determination part 64, and a multiplier 69 for multiplying the power control amount determined in the power control amount determination part 64 and a reception signal(s). Next, points that are different from the second embodiment of the present invention shown in Fig. 5 are described in detail.

[0063] In Fig. 7, first, a pilot signal(s) inserted in the transmission apparatus is generated in the transmission apparatus insertion pilot signal generation part 62. The channel estimation part 63 estimates the channel between the transmission apparatus and the wireless relay apparatus in accordance with the reception signal corresponding to the pilot signal, and outputs the estimation result to the power control amount determination part 64. The power control amount determination part 64 determines the amount of power to be provided for each sub-carrier based on the state of the channel of each sub-carrier obtained from the channel estimation part 63. In determining the power control amount, a water filling theorem, for example, may be employed for obtaining a suitable result. The power control amount in a case of employing the water filling theorem can be expressed with the formula shown below.

$$\text{Power control amount} = (\text{reception power of each sub-carrier})^{0.5} \times (\text{constant})$$

[0064] Here, the constant is a value determined by a condition of making the relay gain in all bands constant. Furthermore, such value may be controlled by a feedback signal that is transmitted from a reception apparatus based on the reception quality of the reception apparatus.

[0065] The power control amount determined by the above-described formula is multiplied by a reception signal at the multiplier 69 and is input to an amplifier 71. Subsequent operations are the same as those described above in the foregoing embodiments.

[0066] In the system executing OFDM communication according to the third embodiment of the present invention, reception quality for receiving relay signals can be enhanced at the reception side since the power amplification factor of the wireless relay apparatus is changed for each sub-carrier.

(Fourth Embodiment)

[0067] In each of the above-described embodiments of the present invention, the transmission apparatus constantly

inserts null signals into the transmission frame even when relay is not executed constantly by the wireless relay apparatus. Nevertheless, the present invention is not limited to such embodiments; alternatively, null signals may be inserted according to necessity.

5 [0068] For example, as shown in a sequence diagram in Fig.8, in a case where a reception apparatus A is unable to receive a control signal from a transmission apparatus ((a) in Fig. 8), the reception apparatus A transmits a predetermined relay request signal to a wireless relay apparatus ((b) in Fig. 8) . Furthermore, before the reception apparatus A commences communication ((d) in Fig. 8), the reception apparatus A informs the transmission apparatus that the communication which is going to be commenced will be executed via the wireless relay apparatus by using a control signal ((c) in Fig.8). By doing so, the transmission apparatus is able to know that the reception apparatus A requests relay via the wireless relay apparatus.

10 [0069] Meanwhile, the reception apparatus B does not transmit the above-described relay request signal since the reception apparatus B is able to receive a control signal from the transmission apparatus ((a') in Fig.8). The transmission apparatus is able to know that the reception apparatus B has not requested relay via the wireless relay apparatus since no signal corresponding to (c) is received.

15 [0070] The transmission apparatus stores information whether or not terminal requires relay (for example, using a table) ((e) in Fig.8). The transmission apparatus transmits a transmission frame being inserted with null signals ((f), (g) in Fig.8) to a reception apparatus that is requesting communication via a wireless relay apparatus (in this example, reception apparatus A). The transmission apparatus transmits a transmission frame without insertion of null signals ((h) in Fig.8) to a reception apparatus that is directly communicating with the transmission apparatus (in this example, reception apparatus B).

20 [0071] Accordingly, loss of throughput due to insertion of null signals can be prevented with respect to the reception apparatus that does not communicate via the wireless relay apparatus.

[0072] The fourth embodiment of the present invention also requires to constantly insert null signals into the relay frame of the control signal, or to employ another method or part for canceling coupling loop interference.

25 [0073] Fig.9 is a drawing showing an exemplary configuration of a transmission apparatus according to the fourth embodiment of the present invention. The transmission apparatus according to the fourth embodiment of the present invention has a configuration which is basically the same as that of the transmission apparatus shown in Fig.3, except that a frame generation rule determination part 77 is added. The frame generation rule determination part 77 has a function of determining whether null signals are inserted.

30 [0074] The frame generation rule determination part 77, as shown in the sequence diagram in Fig. 8, monitors relay request signals from each reception apparatus (here, the signals are referred to as feedback signals from the reception apparatus), determines whether null signals are inserted with respect to each of the reception apparatuses using, for example, a table. Furthermore, the frame generation rule determination part 77 outputs the determination results to a frame generation part 78 at a predetermined timing. In accordance with the determination results output from the frame generation rule determination part 77, the frame generation part 78 controls insertion of null signals into the transmission frame.

35 [0075] According to the fourth embodiment of the present invention, overhead due to insertion of null signals can be reduced for a reception apparatus that does not communicate via a wireless relay apparatus; thereby the throughput of the reception apparatus can be enhanced.

40 (Fifth Embodiment)

[0076] Fig.10 is a drawing showing an exemplary configuration of a wireless relay apparatus according to a fifth embodiment of the present invention.

45 [0077] In Fig.10, the wireless relay apparatus includes a reception antenna 81, a reception part 82, a two symbol delay element 83, a subtractor 84, an FIR filter 85, a coefficient determination part 86, a pilot signal generation part 87, a pilot insertion timing detection part 88, a switch circuit 89, and an amplifier 90.

[0078] Here, the fifth embodiment of the present invention is different from the foregoing embodiments in that the two symbol delay element 83 is included. A delay operation of the two symbol delay element 83 is described with reference to Figs. 11A-11F. In Figs.11A-11F, letter D indicates a delay element (Delay Line). Since the fifth embodiment of the present invention employs the two symbol delay element 83, letter D is serially allocated in two steps.

50 [0079] Fig.11A shows an initial state prior to inputting symbols to the two symbol delay element 83. First, a reception of a first symbol in a forthcoming timing (Fig.11B) triggers a delay of two symbols for the symbols input in the two symbol delay element 83. After the two symbol delay of the symbols in the two symbol delay element 83, a pilot signal (letter P) generated in a pilot signal generation part 87 is transmitted in a timing of receiving a second symbol (Fig. 11C) .

55 [0080] By transmitting the pilot signal, the wireless relay apparatus receives a reception signal corresponding to the pilot signal in a timing of receiving the second symbol (in this case, the second symbol is a null signal). While a third symbol is being received in a reception part 82 of the wireless relay apparatus, a coefficient determination part 86 of the

wireless relay apparatus estimates the channel of the coupling loop interference wave in accordance with the reception signal and the pilot signal, determines the coefficient of the FIR filter 85, and sets a coefficient capable of canceling the coupling loop interference wave, to an FIR filter 85 (Fig. 11D). In the timing for transmitting the second symbol, a coupling loop interference wave of the first symbol added to the reception signal of the third symbol is cancelled (Fig. 11E). Then,

the third symbol is transmitted in a forthcoming timing (Fig. 11F).
[0081] The fifth embodiment of the present invention is effective in a case where no or very weak direct waves are transmitted from the transmission apparatus to the reception apparatus, and is also effective in a case where it is allowed a large process delay of the wireless relay apparatus, since digital signal processing is also executed in the wireless relay apparatus.

(Sixth Embodiment)

[0082] A sixth embodiment of the present invention is a case where MIMO (Multiple Input Multiple Output) channel signal transmission is applied to the wireless relay apparatus of the present invention. MIMO channel signal transmission is a signal transmission method in which multiple information sequences are wirelessly transmitted in the same frequency band by a transmission apparatus, and radio signals on the same frequency band are received and separated into respective information sequences by a reception apparatus.

[0083] First, an operation of a conventional MIMO channel signal transmission method is described. Fig. 12 is a drawing showing an exemplary configuration of a multi-point relay transmission system according to the conventional MIMO channel signal transmission method.

[0084] In the multi-point relay transmission system shown in Fig. 12, a transmission apparatus 100 transmits M number (M being an integer which is not less than 2) of information sequences S_1, \dots, S_M from its transmission antennas As_1, \dots, As_M in the form of vertical polarized plane wave radio signals of the same frequency band. L number (L being an integer which is not less than 1) of wireless relay apparatuses $110_1, \dots, 110_L$ receive M radio signals and temporarily store the radio signals. Then, when the transmission apparatus 100 stops transmission after a transmission amounting to a single message or a single burst is completed, the stored radio signals are amplified and transmitted to a reception apparatus 120 in the form of vertical polarized plane wave radio signals. A reception apparatus 120 receives the radio signals at its N number (N being an integer which is not less than M) of linearly polarized wave reception antennas Ar_1, \dots, Ar_N and separates the received signals to M information sequences S_1, \dots, S_M by applying an MIMO equalization process thereto.

[0085] Fig. 13 is a drawing showing an exemplary configuration of a wireless relay apparatus used for the above-described MIMO channel configuration. The wireless relay apparatus according to the sixth embodiment of the present invention may include a different polarization plane wave relay function.

[0086] The wireless relay apparatus shown in Fig. 13 includes: U number (U being an integer which is not less than 1) of first polarization reception antennas; V number (V being an integer which is not less than 1) of second polarization reception antennas having an orthogonal polarization characteristic to that of the first reception antenna; U second polarization transmission antennas having an orthogonal polarization characteristic to that of the first polarization reception antenna; and V first polarization transmission apparatuses having a polarization characteristic orthogonalized to that of the second polarization reception antenna.

[0087] The example shown in Fig. 13 is a case where $U = V = 1$. In Fig. 13, the two antennas having polarization characteristics orthogonalized to each other are shown in a manner where one is illustrated as a triangle having its apex facing downward (inverted triangle) and the other is illustrated as a triangle having its apex facing upward.

[0088] The wireless relay apparatus in Fig. 13 includes a first polarization reception antenna 150_1 and a second polarization reception antenna 150_2 . The radio signals received in the first and second polarization reception antennas 150_1 and 150_2 are suppressed in coupling loop interference suppression parts 154_1 and 154_2 , and are supplied to amplifiers 153_1 and 153_2 . The radio signals amplified by amplifiers 153_1 and 153_2 are transmitted from the first and second polarization transmission antennas 151_1 and 151_2 .

[0089] In a case where the present invention is applied to the wireless relay apparatus including a different polarization plane wave relay function, the coupling loop interference suppression parts 154_1 and 154_2 may have a configuration similar to the configuration of the wireless relay apparatus shown in Fig. 2 (however, excluding the amplifier 19). Accordingly, in a case of executing relay with the same frequency, oscillation due to coupling loop interference can be prevented with more accuracy and multiple radio signals with the same frequency with orthogonalized polarization can simultaneously be relayed and amplified with a relatively high gain.

[0090] Fig. 14 is another embodiment where MIMO channel signal transmission is applied to the wireless relay apparatus of the present invention.

[0091] In this embodiment, when the reception radio signal of the second polarization reception antenna 150_2 is transmitted from the first polarization transmission apparatus 151_2 and is received at the first polarization reception antenna 150_1 as a coupling loop interference signal, the coupling loop interference signal is suppressed. That is, when

a coupling loop signal enters the closed loop, the coupling loop signal is suppressed before passing through the amplifier. Accordingly, the transmission channel characteristic (also referred to as impulse response, channel characteristic) of a coupling loop interference transmission channel 170, through which the coupling loop interference signal is transmitted from the first polarization transmission antenna 151₂ to the first polarization reception antenna 150₁, is estimated by a coupling loop interference channel estimation part 180₁.

[0092] The characteristic of the coupling loop interference transmission channel 170, which is estimated by the coupling loop interference channel estimation part 180₁, is convoluted in an FIR filter 182₁ with respect to the signal received in the second polarization reception antenna 150₂ (in this example, the signal input to the amplifier 153₂), to thereby generate a replica of the coupling loop interference signal of the coupling loop interference transmission channel 170. The replica of the coupling loop interference signal is subtracted from the reception radio signal of the first polarization reception antenna 150₁ by a subtractor part 183₁. The signal output from the subtractor part 183₁ is input to the amplifier 153₁.

[0093] Accordingly, from the reception radio signal of the first polarization reception antenna 150₁, the reception radio signal of the second polarization reception antenna 150₂, which is transmitted to first polarization reception antenna 150₁ via the coupling loop interference transmission channel 170 as the coupling loop interference signal, is suppressed by the coupling loop interference signal replica from the FIR filter 182₁. That is, coupling loop interference signal is suppressed before the reception radio signal of the second polarization reception antenna 150₂ is input to the closed loop, thereby preventing the coupling loop interference signal from being amplified by the amplifier and noise from being created.

[0094] Accordingly, by applying the present invention to a system executing MIMO channel signal transmission, oscillation due to coupling loop interference waves can be prevented with high accuracy and channel capacity between the transmission apparatus and the reception apparatus can be increased with the MIMO channel configuration.

[0095] Further, the present invention is not limited to these embodiments, but variations and modifications may be made without departing from the scope of the present invention.

Claims

1. A wireless relay system for relaying a radio signal transmitted from a first wireless station (1) to a second wireless station (3) via a wireless relay apparatus (2), the wireless relay system comprising:

a relay control part for receiving transmission symbols transmitted from the first wireless station and refraining from relaying a portion of the symbols;

a pilot signal transmission part for transmitting a pilot signal that is inserted into a section of the portion of the transmission symbols;

a coupling loop interference wave estimation part for receiving the pilot signal and estimating a coupling loop interference wave based on the pilot signal; and

a coupling loop interference wave cancellation part for subtracting the estimated coupling loop interference wave from a reception signal;

characterised in that the portion of the symbols to be refrained from relay is transmitted by the first wireless station, and **in that** the first wireless station includes a control signal transmission part for transmitting a control signal that is included in the transmission symbols transmitted to the wireless relay apparatus, wherein the wireless relay apparatus includes a relay refrain control part for refraining from relaying the radio signals in a section specified by the control signal.

2. The wireless relay system as claimed in claim 1, wherein control signal variably determines the portion of the symbols to be refrained from relay in accordance with a predetermined criterion.

3. The wireless relay system as claimed in claim 1, wherein the control signal transmission part includes a frame generation part (33) for generating a frame of the transmission symbols with a null symbol inserted therein, wherein the relay refraining control part includes a relay refraining part for refraining relay of signals in a section where the null signal is inserted.

4. The wireless relay system as claimed in claim 1, wherein the wireless relay apparatus includes a delay part (83) for delaying the relay of the transmission symbols to an extent of N symbols, wherein N represents an integer which is not less than 1.

5. The wireless relay system as claimed in claim 1, wherein in a case of relaying a signal by using an OFDM transmission method,

the wireless relay apparatus includes an IFFT part (59) for performing an IFFT process to generate the transmission signal, and an FFT part (51) for performing an FFT process on the reception signal, and the first wireless station includes an OFDM frame generation part for inserting a null signal into a portion of a time/frequency domain and generating a frame that is to be transmitted to the wireless relay apparatus.

6. The wireless relay system as claimed in claim 5, wherein the OFDM frame generation part calculates a sub-carrier interval for inserting the null signal in accordance with a formula of $\text{ceil} \{(\text{FFT point value})/(\text{GI point value})\}$, wherein "ceil (x)" represents a numeric function that returns a least integer greater than x, "FFT" represents Fast Fourier Transform and "GI" represents guard interval.

7. The wireless relay system as claimed in claim 6, wherein the wireless relay apparatus includes a channel estimation part (63) for receiving the pilot signal and estimating a channel in accordance with the received pilot signal, and a signal amplitude control part for controlling an amplitude of the reception signal based on a result of the channel estimation by the channel estimation part.

8. The wireless relay system as claimed in claim 7, wherein the signal amplitude control part employs a water filling theorem for controlling the amplitude of the reception signal.

9. The wireless relay system as claimed in claim 1, wherein of the first wireless station, the second wireless station, and the wireless relay apparatus each includes a plurality of antennas, wherein the antennas are used to form a MIMO channel, wherein the relay control part, a pilot signal transmission part, the coupling loop interference wave estimation part, and the coupling loop interference wave cancellation part are employed when executing transmission of MIMO channel signals.

10. A wireless relay apparatus (2) for relaying a radio signal transmitted from a first wireless station (1) to a second wireless station (3), the wireless relay apparatus comprising:

a relay control part for receiving transmission symbols transmitted from the first wireless station and refraining from relaying a portion of the symbols;
 a pilot signal transmission part for transmitting a pilot signal that is inserted into a section of the portion of the transmission symbols;
 a coupling loop interference wave estimation part for receiving the pilot signal and estimating a channel impulse response of coupling loop interference wave based on the pilot signal; and
 a coupling loop interference wave cancellation part for subtracting the estimated coupling loop interference wave from a reception signal;

characterised in that the portion of the symbols to be refrained from relay is transmitted by the first wireless station, and **in that** the first wireless station includes a control signal transmission part for transmitting a control signal that is included in the transmission symbols transmitted to the wireless relay apparatus, wherein the wireless relay apparatus includes a relay refrain control part for refraining from relaying the radio signals in a section specified by the control signal.

11. A wireless relay method for relaying a radio signal transmitted from a first wireless station to a second wireless station, the wireless relay method comprising the steps of:

a) receiving transmission symbols transmitted from the first wireless station;
 b) refraining from relaying a portion of the symbols;
 c) transmitting a pilot signal that is inserted into a section of the portion of the transmission symbols;
 d) receiving the pilot signal;
 e) estimating a coupling loop interference wave based on the pilot signal; and
 f) subtracting the estimated coupling loop interference wave from a reception signal;

characterised in that the portion of the symbols to be refrained from relay is transmitted by the first wireless station, and **in that** the first wireless station transmits a control signal that is included in the transmission symbols transmitted to the wireless relay apparatus, wherein the wireless relay apparatus refrains from relaying the radio signals in a

section specified by the control signal.

Patentansprüche

- 5
1. Drahtloses Relaisystem zum Weiterleiten eines Funksignals, das von einer ersten Funkstation (1) über eine drahtlose Relaisvorrichtung (2) an eine zweite Funkstation (3) übertragen wird, wobei das drahtlose Relaisystem umfasst:
- 10
- einen Relaissteuerteil zum Empfangen von Übertragungssymbolen, die von der ersten Funkstation übertragen werden, und zum Unterlassen der Weiterleitung eines Teils der Symbole;
- einen Pilotsignal-Übertragungsteil zum Übertragen eines Pilotsignals, das in einen Abschnitt des Teils der Übertragungssymbole eingefügt wird;
- einen Koppelschleifen-Störwellen-Schätzteil zum Empfangen des Pilotsignals und zum Schätzen einer Koppelschleifen-Störwelle auf der Basis des Pilotsignals; und
- 15
- einen Koppelschleifen-Störwellen-Auslöschteil zum Subtrahieren der geschätzten Koppelschleifen-Störwelle aus einem Empfangssignal;
- dadurch gekennzeichnet, dass** der Teil der Symbole, dessen Weiterleitung zu unterlassen ist, durch die erste Funkstation übertragen wird und dass die erste Funkstation einen Steuersignal-Übertragungsteil zum Übertragen eines Steuersignals enthält, das in den an die drahtlose Relaisvorrichtung übertragenen Übertragungssymbolen enthalten ist, worin die drahtlose Relaisvorrichtung einen Relaisunterlassungs-Steuerteil zum Unterlassen der Weiterleitung der Funksignale in einem durch das Steuersignal spezifizierten Abschnitt enthält.
- 20
2. Drahtloses Relaisystem nach Anspruch 1, worin das Steuersignal gemäß einem vorbestimmten Kriterium den Teil der Symbole variabel bestimmt, dessen Weiterleitung zu unterlassen ist.
- 25
3. Drahtloses Relaisystem nach Anspruch 1, worin der Steuersignal-Übertragungsteil einen Rahmenerzeugungsteil (33) zum Erzeugen eines Rahmens der Übertragungssymbole mit einem darin eingefügten Nullsymbol enthält, worin der Relaisunterlassungs-Steuerteil einen Relaisunterlassungsteil enthält, um das Weiterleiten von Signalen in einem Abschnitt zu unterlassen, wo das Nullsignal eingefügt ist.
- 30
4. Drahtloses Relaisystem nach Anspruch 1, worin die drahtlose Relaisvorrichtung einen Verzögerungsteil (83) zum Verzögern der Weiterleitung der Übertragungssymbole einer Länge von N Symbolen enthält, worin N eine ganze Zahl nicht kleiner als 1 repräsentiert.
- 35
5. Drahtloses Relaisystem nach Anspruch 1, worin in einem Fall der Weiterleitung eines Signals unter Verwendung eines OFDM-Übertragungsverfahrens:
- 40
- die drahtlose Relaisvorrichtung einen IFFT-Teil (59) zum Ausführen eines IFFT-Prozesses enthält, um das Übertragungssignal zu erzeugen, und einen FFT-Teil (51) zum Ausführen eines FFT-Prozesses am Empfangssignal, und
- die erste Funkstation einen OFDM-Rahmenerzeugungsteil zum Einfügen eines Nullsignals in einen Teil einer Zeit/Frequenz-Domäne und zum Erzeugen eines Rahmens enthält, der an die drahtlose Relaisvorrichtung zu übertragen ist.
- 45
6. Drahtloses Relaisystem nach Anspruch 5, worin der OFDM-Rahmenerzeugungsteil ein Subträgerintervall zum Einfügen des Nullsignals gemäß folgender Formel berechnet:
- 50
- $$\text{ceil}\{(\text{FFT-Punktwert})/(\text{GI-Punktwert})\},$$
- worin "ceil(x)" eine numerische Funktion darstellt, die eine kleinste ganze Zahl größer als x ausgibt, "FFT" die schnelle Fouriertransformation repräsentiert und "GI" das Schutzintervall repräsentiert.
- 55
7. Drahtloses Relaisystem nach Anspruch 6, worin die drahtlose Relaisvorrichtung einen Kanalschätzteil (63) zum Empfangen des Pilotsignals und zum Schätzen eines Kanals gemäß dem empfangenen Pilotsignal enthält, und einen Signalamplituden-Steuerteil zum Steuern einer Amplitude des Empfangssignals auf der Basis eines Ergeb-

nisses der Kanalschätzung durch den Kanalschätzteil.

8. Drahtloses Relaisystem nach Anspruch 7, worin der Signalamplituden-Steuerteil ein "Water Filling"(Wasserfüll)-Theorem anwendet, um die Amplitude des Empfangssystems zu steuern.

9. Drahtloses Relaisystem nach Anspruch 1, worin die erste Funkstation, die zweite Funkstation und die drahtlose Relaisvorrichtung alle eine Vielzahl von Antennen enthalten, worin die Antennen verwendet werden, um einen MIMO (Mehrfacheingang/Mehrfachausgang)-Kanal zu formen, worin der Relaissteuerteil, ein Pilotsignal-Übertragungsteil, der Koppelschleifen-Störwellen-Schätzteil und der Koppelschleifen-Störwellen-Auslöschteil beim Ausführen der Übertragung von MIMO-Kanalsignalen eingesetzt werden.

10. Drahtlose Relaisvorrichtung (2) zum Weiterleiten eines Funksignals, das von einer ersten Funkstation (1) an eine zweite Funkstation (3) übertragen wird, wobei die drahtlose Relaisvorrichtung umfasst:

einen Relaissteuerteil zum Empfangen von Übertragungssymbolen, die von der ersten Funkstation übertragen werden, und zum Unterlassen der Weiterleitung eines Teils der Symbole;
einen Pilotsignal-Übertragungsteil zum Übertragen eines Pilotsignals, das in einen Abschnitt des Teils der Übertragungssymbole eingefügt wird;
einen Koppelschleifen-Störwellen-Schätzteil zum Empfangen des Pilotsignals und zum Schätzen einer Kanalimpulsantwort einer Koppelschleifen-Störwelle auf der Basis des Pilotsignals; und
einen Koppelschleifen-Störwellen-Auslöschteil zum Subtrahieren der geschätzten Koppelschleifen-Störwelle aus einem Empfangssignal;

dadurch gekennzeichnet, dass der Teil der Symbole, dessen Weiterleitung zu unterlassen ist, durch die erste Funkstation übertragen wird und dass die erste Funkstation einen Steuersignal-Übertragungsteil zum Übertragen eines Steuersignals enthält, das in den an die drahtlose Relaisvorrichtung übertragenen Übertragungssymbolen enthalten ist, worin die drahtlose Relaisvorrichtung einen Relaisunterlassungs-Steuerteil zum Unterlassen der Weiterleitung der Funksignale in einem Abschnitt enthält, der durch das Steuersignal spezifiziert wird.

11. Drahtlose Relaisverfahren zum Weiterleiten eines Funksignals, das von einer ersten Funkstation an eine zweite Funkstation übertragen wird, wobei das drahtlose Relaisverfahren folgende Schritte umfasst:

a) Empfangen von Übertragungssymbolen, die von der ersten Funkstation übertragen werden;
b) Unterlassen der Weiterleitung eines Teils der Symbole;
c) Übertragen eines Pilotsignals, das in einen Abschnitt des Teils der Übertragungssymbole eingefügt ist;
d) Empfangen des Pilotsignals;
e) Schätzen einer Koppelschleifen-Störwelle auf der Basis des Pilotsignals; und
f) Subtrahieren der geschätzten Koppelschleifen-Störwelle aus einem Empfangssignal;

dadurch gekennzeichnet, dass der Teil der Symbole, dessen Weiterleitung zu unterlassen ist, durch die erste Funkstation übertragen wird und dass die erste Funkstation ein Steuersignal überträgt, das in den Übertragungssymbolen enthalten ist, die an die drahtlose Relaisvorrichtung übertragen werden, worin die drahtlose Relaisvorrichtung es unterlässt, die Funksignale in einem Abschnitt weiterzuleiten, der durch das Steuersignal spezifiziert wird.

Revendications

1. Système de relais sans fil destiné à relayer un signal radio transmis d'une première station sans fil (1) à une seconde station sans fil (3) via un dispositif de relais sans fil (2), le système de relais sans fil comportant :

une partie de commande de relais pour recevoir des symboles de transmission transmis à partir de la première station sans fil et interdire le relais d'une partie des symboles ;
une partie de transmission de signal pilote pour transmettre un signal pilote qui est inséré dans une section de la partie des symboles de transmission ;
une partie d'estimation d'onde de brouillage de sonde inductive pour recevoir le signal pilote et estimer une onde de brouillage de sonde inductive sur la base du signal pilote ; et
une partie de suppression d'onde de brouillage de sonde inductive pour soustraire l'onde de brouillage de sonde inductive estimée d'un signal de réception ;

caractérisé en ce que la partie des symboles dont le relais est interdit est transmise par la première station sans fil, et **en ce que** la première station sans fil comporte une partie de transmission de signal de commande pour transmettre un signal de commande qui est inclus dans les symboles de transmission transmis au dispositif de relais sans fil, dans lequel le dispositif de relais sans fil comporte une partie de commande d'interdiction de relais pour interdire le relais des signaux radio dans une section spécifiée par le signal de commande.

- 5
2. Système de relais sans fil selon la revendication 1, dans lequel le signal de commande détermine de manière variable la partie des symboles dont le relais est interdit selon un critère prédéterminé.
- 10
3. Système de relais sans fil selon la revendication 1, dans lequel la partie de transmission de signal de commande comporte une partie de génération de trames (33) pour générer une trame des symboles de transmission avec un symbole nul introduit dans celle-ci, dans lequel la partie de commande d'interdiction de relais comporte une partie d'interdiction de relais pour interdire de relayer des signaux dans une section où le signal nul est inséré.
- 15
4. Système de relais sans fil selon la revendication 1, dans lequel le dispositif de relais sans fil comporte une partie de retard (83) pour retarder le relais des symboles de transmission d'une longueur de N symboles, où N représente un nombre entier qui n'est pas inférieur à 1.
- 20
5. Système de relais sans fil selon la revendication 1, dans lequel, dans le cas du relais d'un signal en faisant appel à un procédé de transmission OFDM,

le dispositif de relais sans fil comporte une partie IFFT (59) pour mettre en oeuvre un processus IFFT en vue de générer le signal de transmission, et une partie FFT (51) pour mettre en oeuvre un processus FFT sur le signal de réception, et

25 la première station sans fil comporte une partie de génération de trames OFDM pour insérer un signal nul dans une partie d'un domaine temps/fréquence et générer une trame qui doit être transmise au dispositif de relais sans fil.

30

6. Système de relais sans fil selon la revendication 5, dans lequel la partie de génération de trames OFDM calcule un intervalle de sous-porteuse pour insérer le signal nul selon une formule de modèle « ceil » $\{(\text{valeur de point de FFT}) / (\text{valeur de point de GI}) \}$, dans laquelle « ceil (x) » représente une fonction numérique qui retourne un entier moindre supérieur à x, « FFT » représente une transformée de Fourier rapide et « GI » représente un intervalle de garde.

35

7. Système de relais sans fil selon la revendication 6, dans lequel le dispositif de relais sans fil comporte une partie d'estimation de canal (63) pour recevoir le signal pilote et estimer un canal selon le signal pilote reçu, et une partie de commande d'amplitude de signal pour commander l'amplitude du signal de réception sur la base d'un résultat de l'estimation de canal par la partie d'estimation de canal.

40

8. Système de relais sans fil selon la revendication 7, dans lequel la partie de commande d'amplitude de signal utilise un théorème de spectre de canal pour commander l'amplitude du signal de réception.

45

9. Système de relais sans fil selon la revendication 1, dans lequel la première station sans fil, la seconde station sans fil, et le dispositif de relais sans fil comporte chacun une pluralité d'antennes, où les antennes sont utilisées pour former un canal MIMO, dans lequel la partie de commande de relais, une partie de transmission de signal pilote, la partie d'estimation d'onde de brouillage de sonde inductive, et la partie de suppression d'onde de brouillage de sonde inductive sont utilisées lors de la mise en oeuvre d'une transmission de signaux de canal MIMO.

50

10. Dispositif de relais sans fil (2) destiné à relayer un signal radio transmis d'une première station sans fil (1) à une seconde station sans fil (3) le dispositif de relais sans fil comportant :

une partie de commande de relais pour recevoir des symboles de transmission transmis à partir de la première station sans fil et interdire le relais d'une partie des symboles ;

55 une partie de transmission de signal pilote pour transmettre un signal pilote qui est inséré dans une section de la partie des symboles de transmission ;

une partie d'estimation d'onde de brouillage de sonde inductive pour recevoir le signal pilote et estimer une réponse impulsionnelle de canal d'onde de brouillage de sonde inductive sur la base du signal pilote ; et

une partie de suppression d'onde de brouillage de sonde inductive pour soustraire l'onde de brouillage de sonde

EP 1 566 900 B1

inductive estimée d'un signal de réception ;

5 **caractérisé en ce que** la partie des symboles dont le relais est interdit est transmise par la première station sans fil, et **en ce que** la première station sans fil comporte une partie de transmission de signal de commande pour transmettre un signal de commande qui est inclus dans les symboles de transmission transmis au dispositif de relais sans fil, dans lequel le dispositif de relais sans fil comporte une partie de commande d'interdiction de relais pour interdire le relais des signaux radio dans une section spécifiée par le signal de commande.

10 **11.** Procédé de relais sans fil pour relayer un signal radio transmis d'une première station sans fil à une seconde station sans fil, le procédé de relais sans fil comportant les étapes ci-dessous consistant à :

- 15 a) recevoir des symboles de transmission transmis à partir de la première station sans fil ;
b) interdire le relais d'une partie des symboles ;
c) transmettre un signal pilote qui est inséré dans une section de la partie des symboles de transmission ;
d) recevoir le signal pilote ;
e) estimer une onde de brouillage de sonde inductive sur la base du signal pilote ; et
f) soustraire l'onde de brouillage de sonde inductive estimée d'un signal de réception ;

20 **caractérisé en ce que** la partie des symboles dont le relais est interdit est transmise par la première station sans fil, et **en ce que** la première station sans fil transmet un signal de commande qui est inclus dans les symboles de transmission transmis au dispositif de relais sans fil, dans lequel le dispositif de relais sans fil interdit le relais des signaux radio dans une section spécifiée par le signal de commande.

25

30

35

40

45

50

55

FIG.1

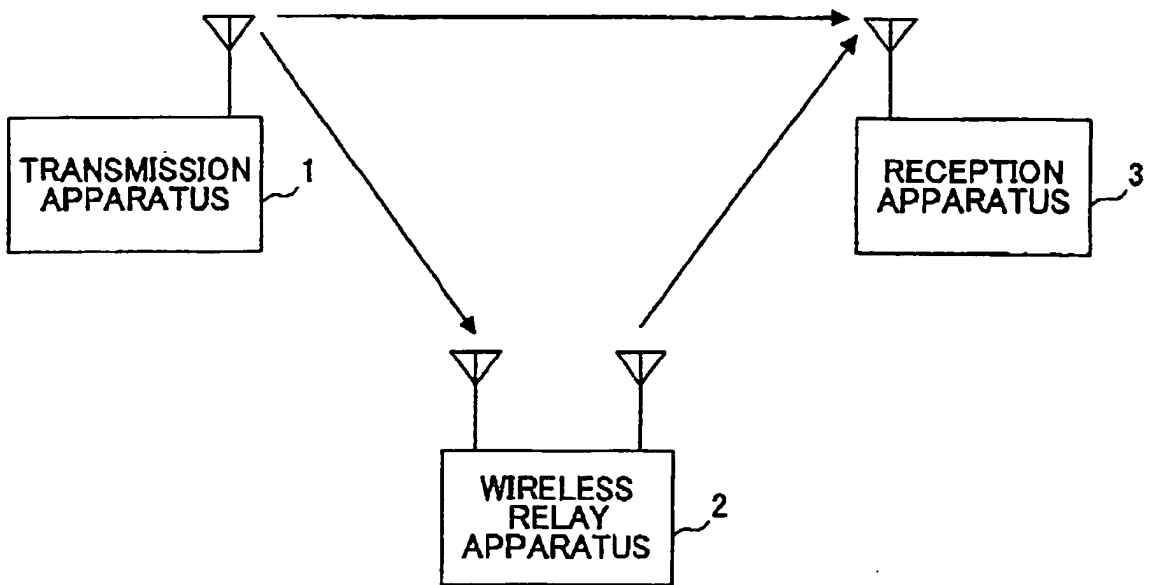
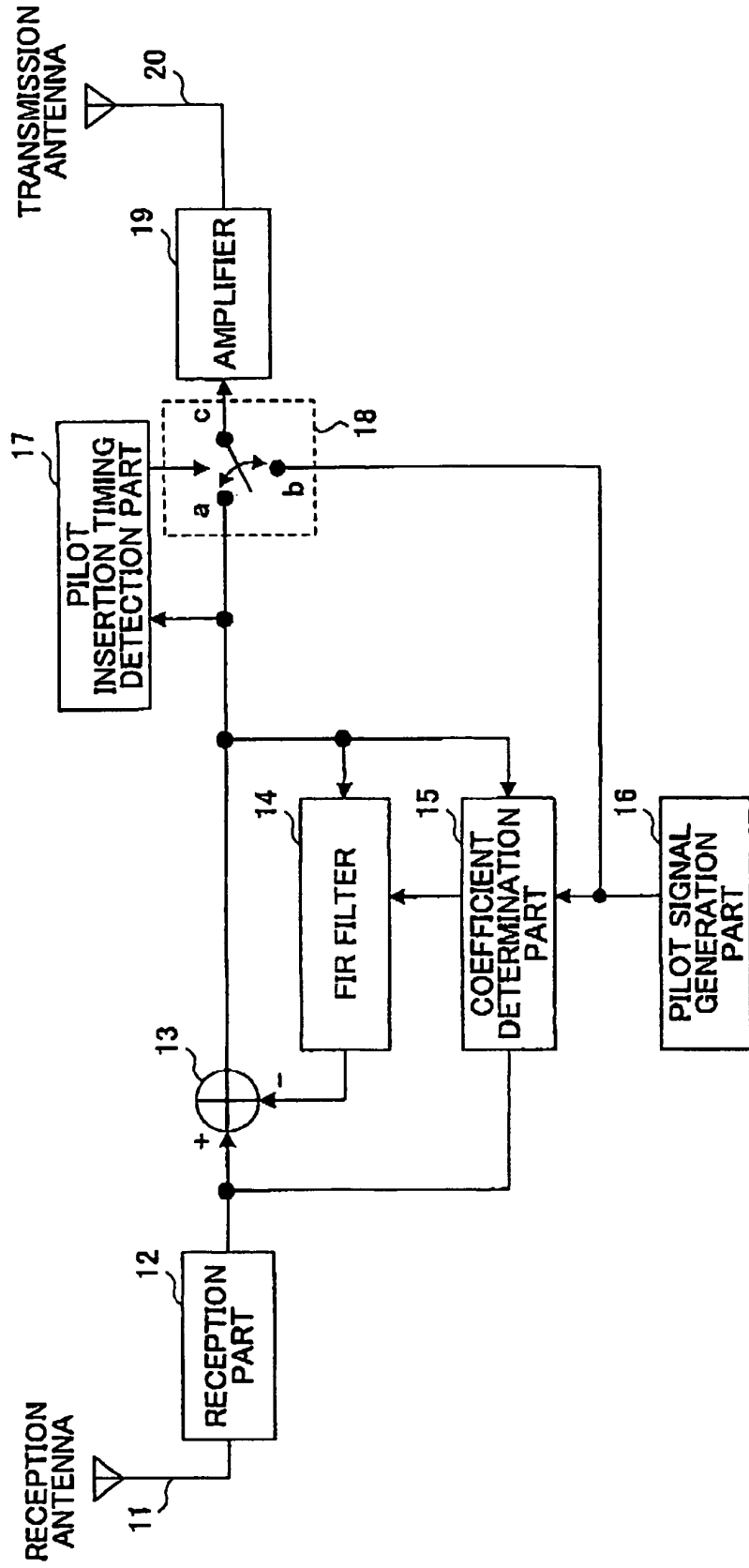

FIG.2



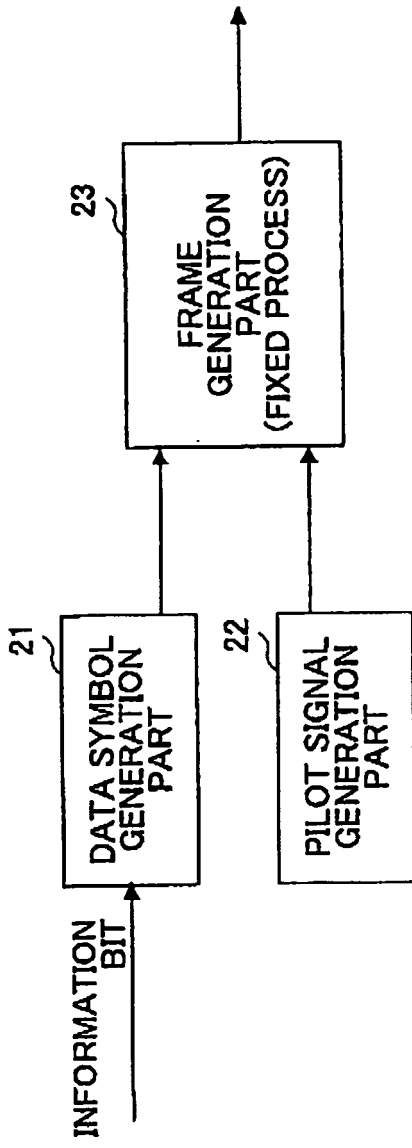

FIG.3A

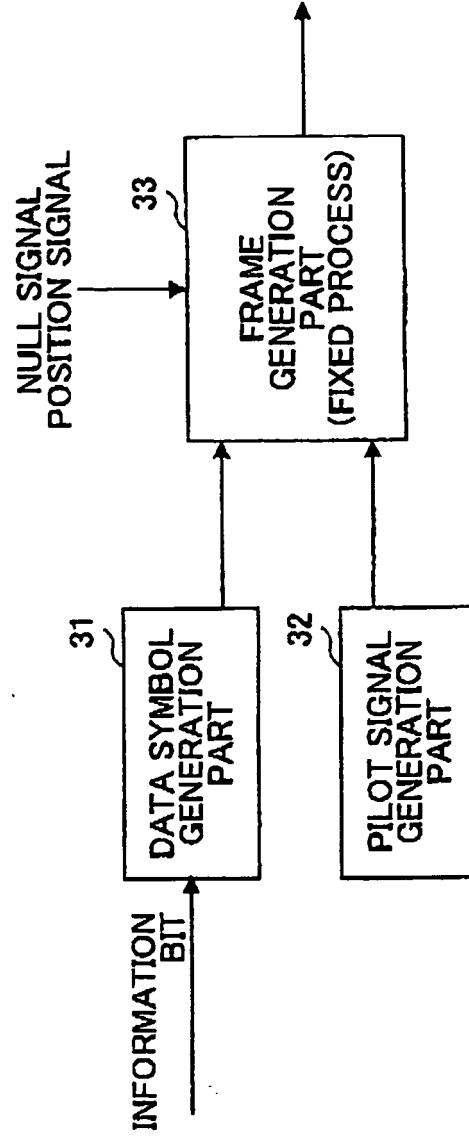

FIG.3B

FIG.4

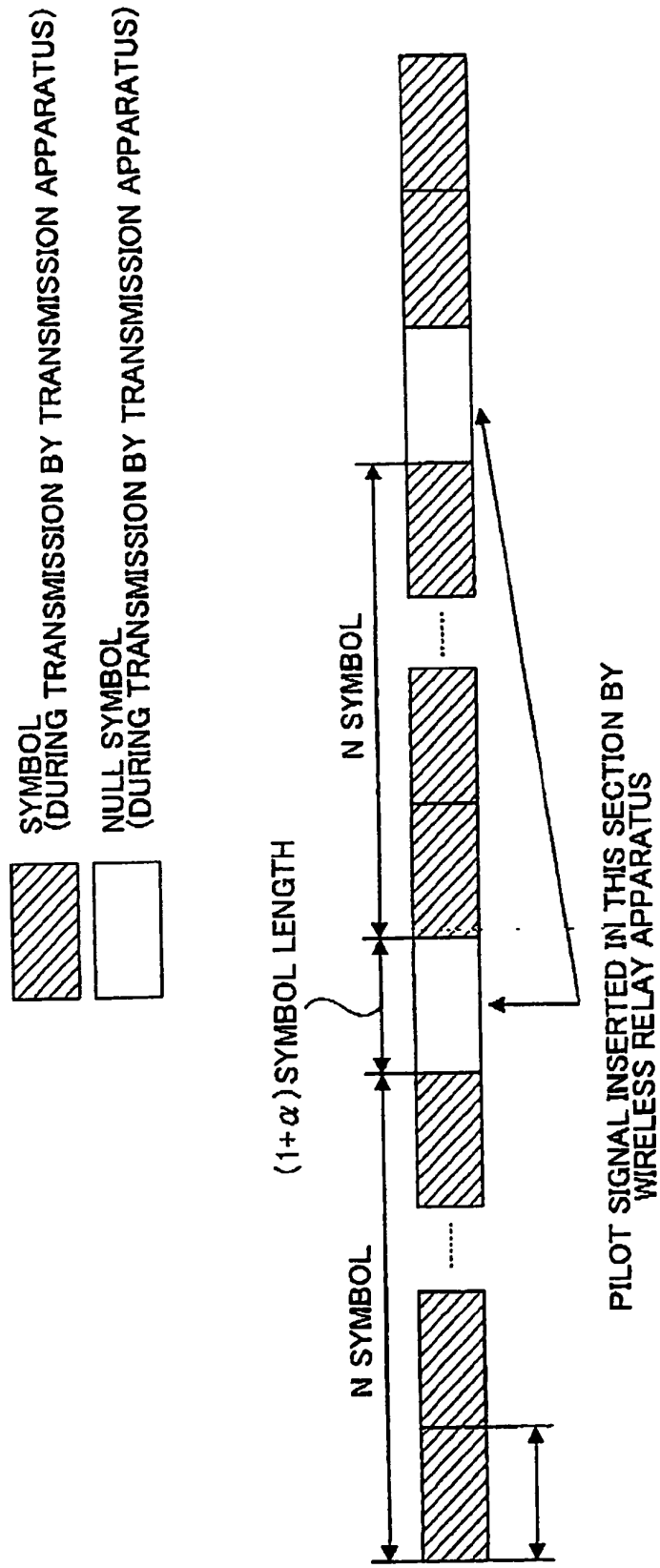

FIG.5

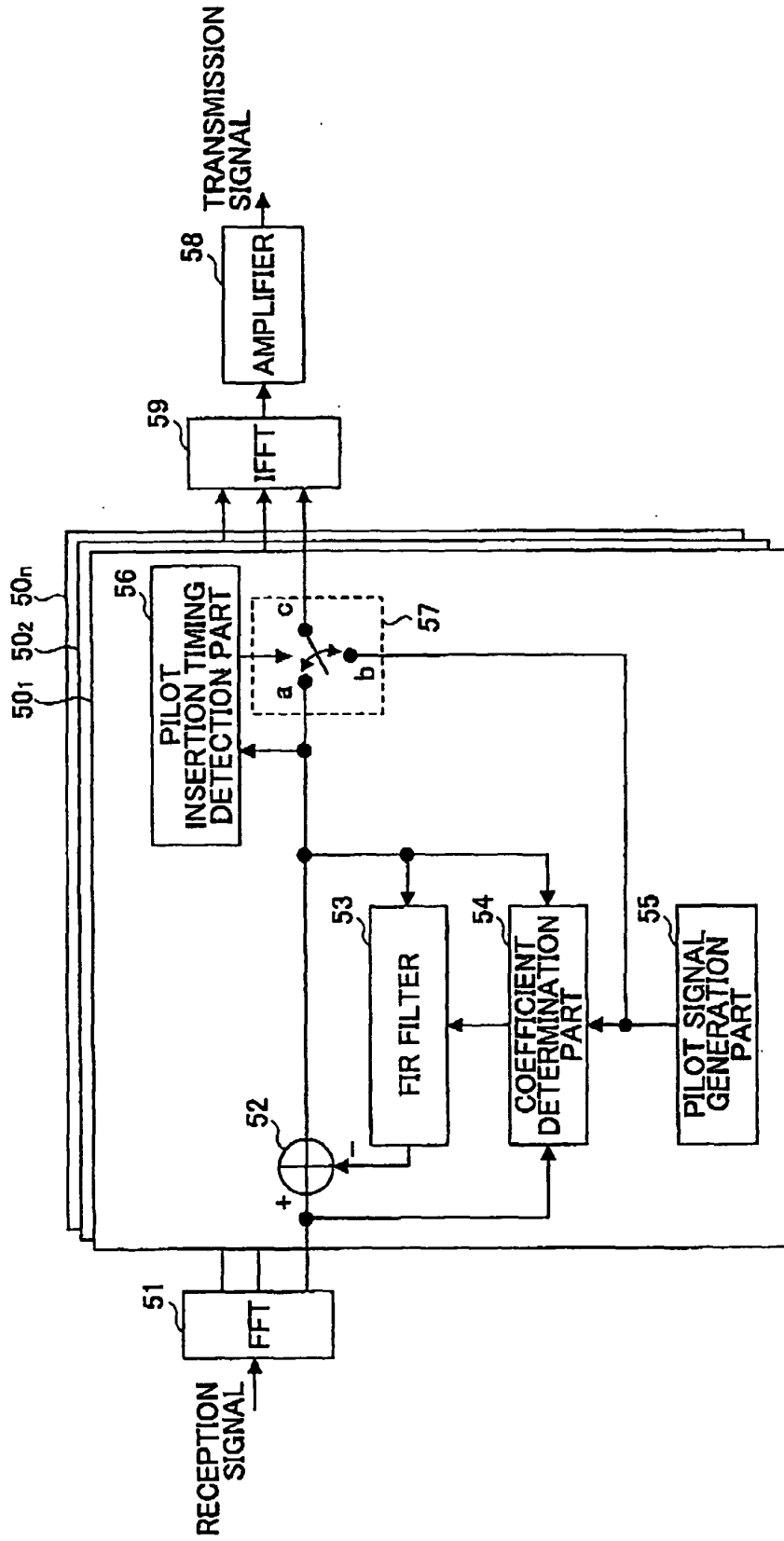

FIG.6

SYMBOL
(DURING TRANSMISSION BY TRANSMISSION APPARATUS)

NULL SYMBOL
(DURING TRANSMISSION BY TRANSMISSION APPARATUS)

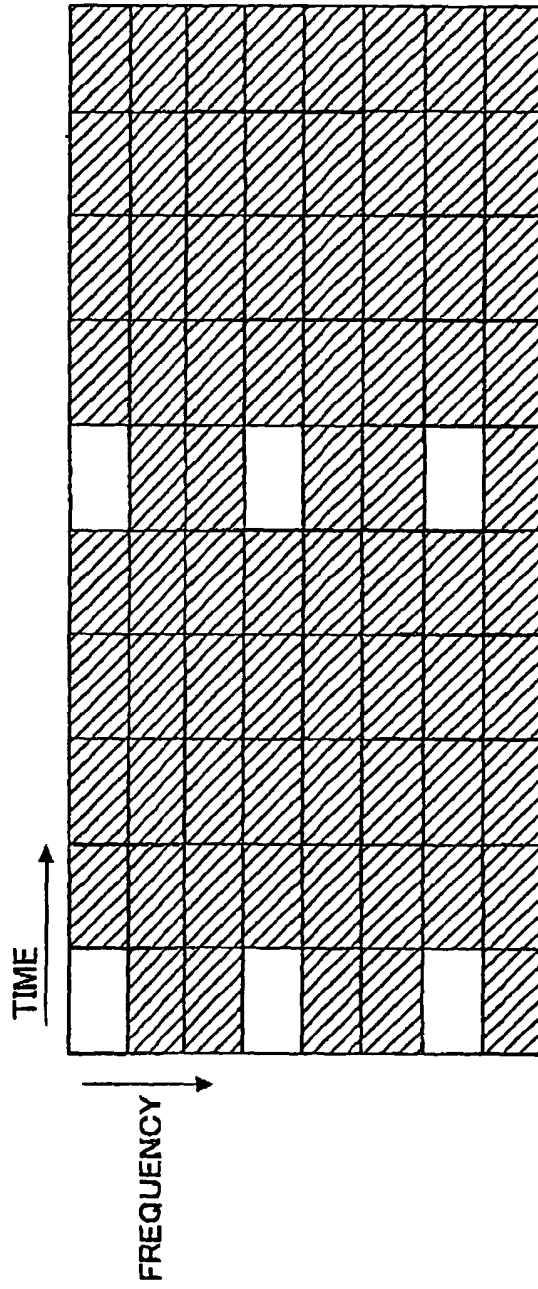
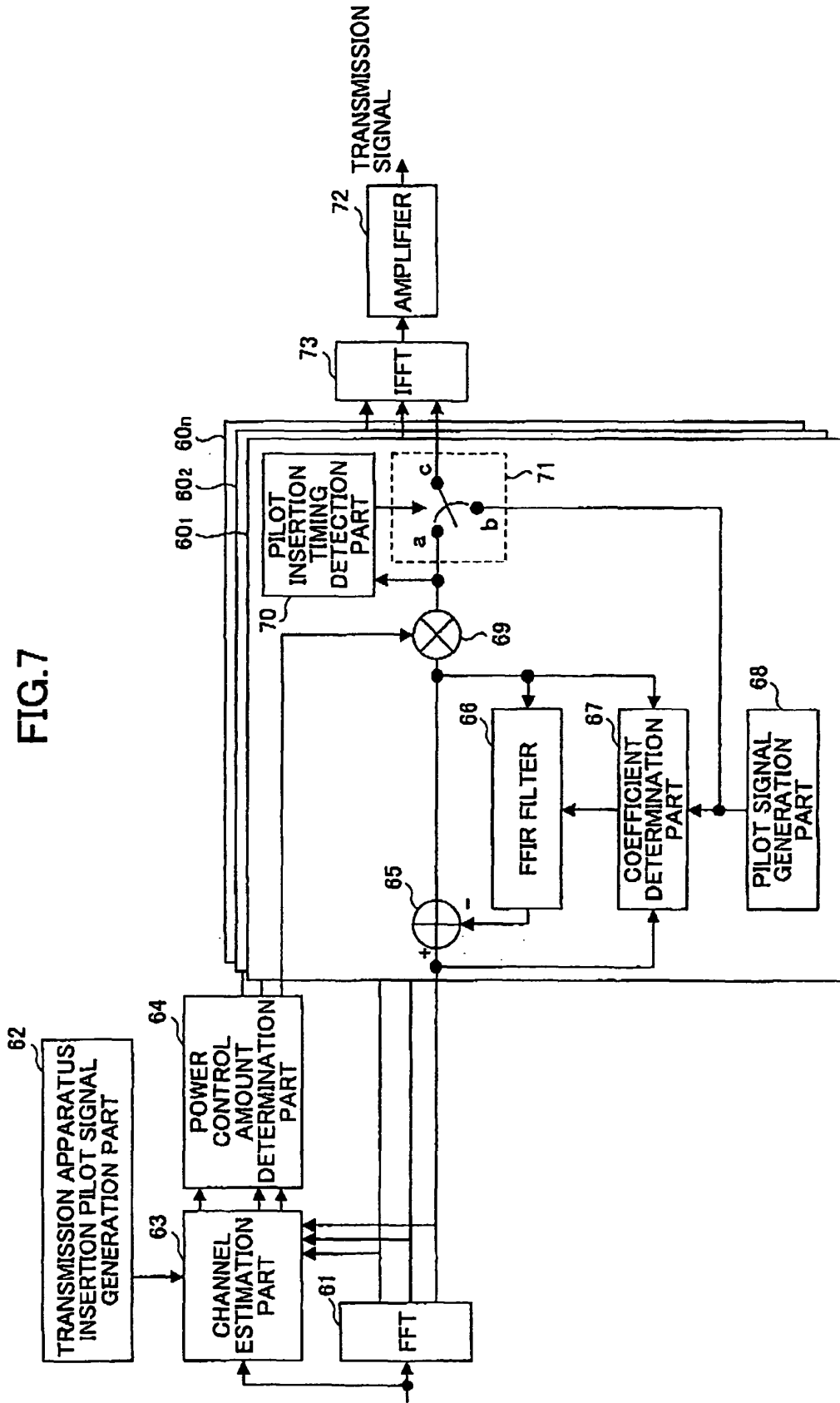

FIG.7



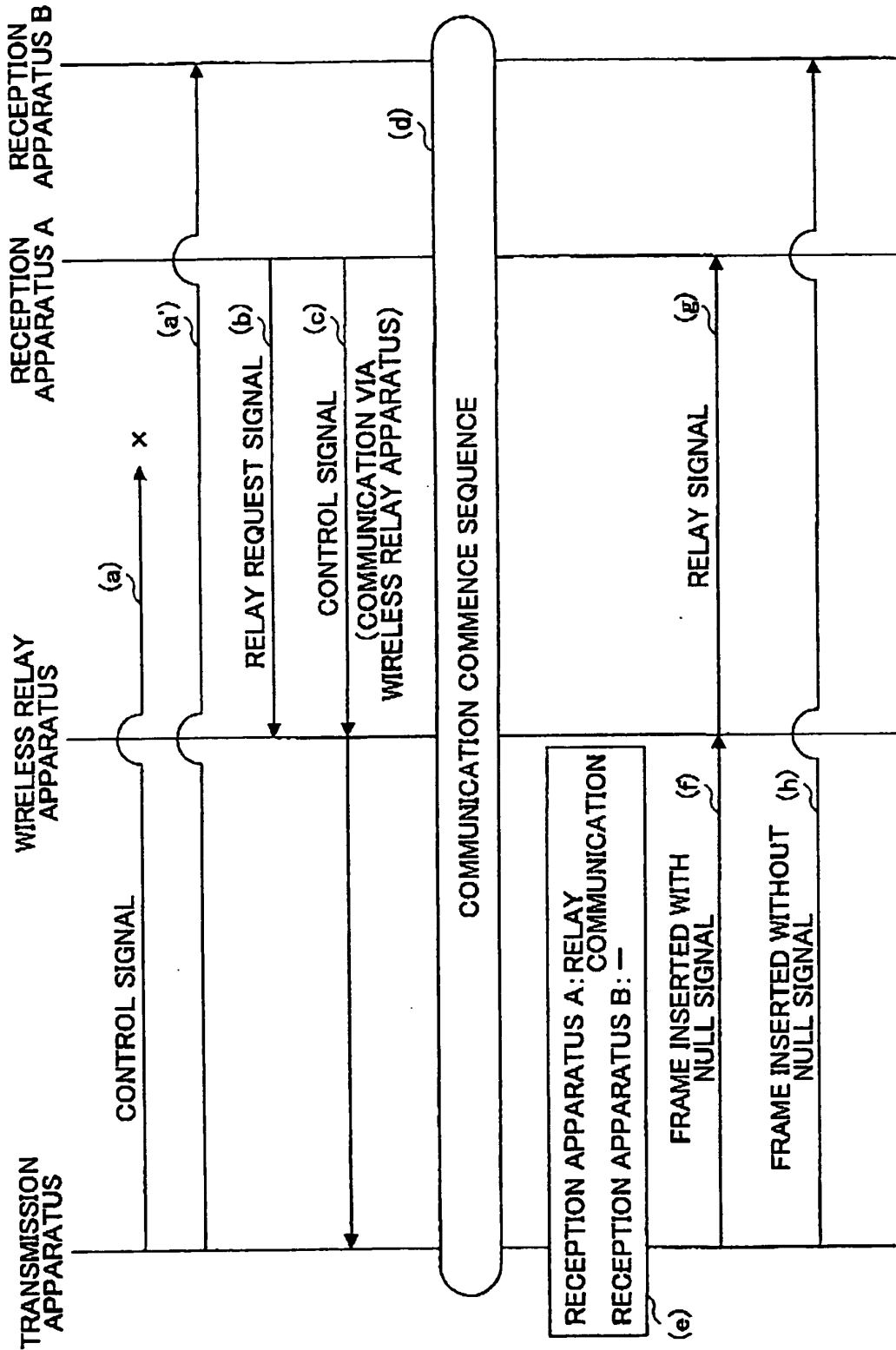

FIG.8

FIG.9

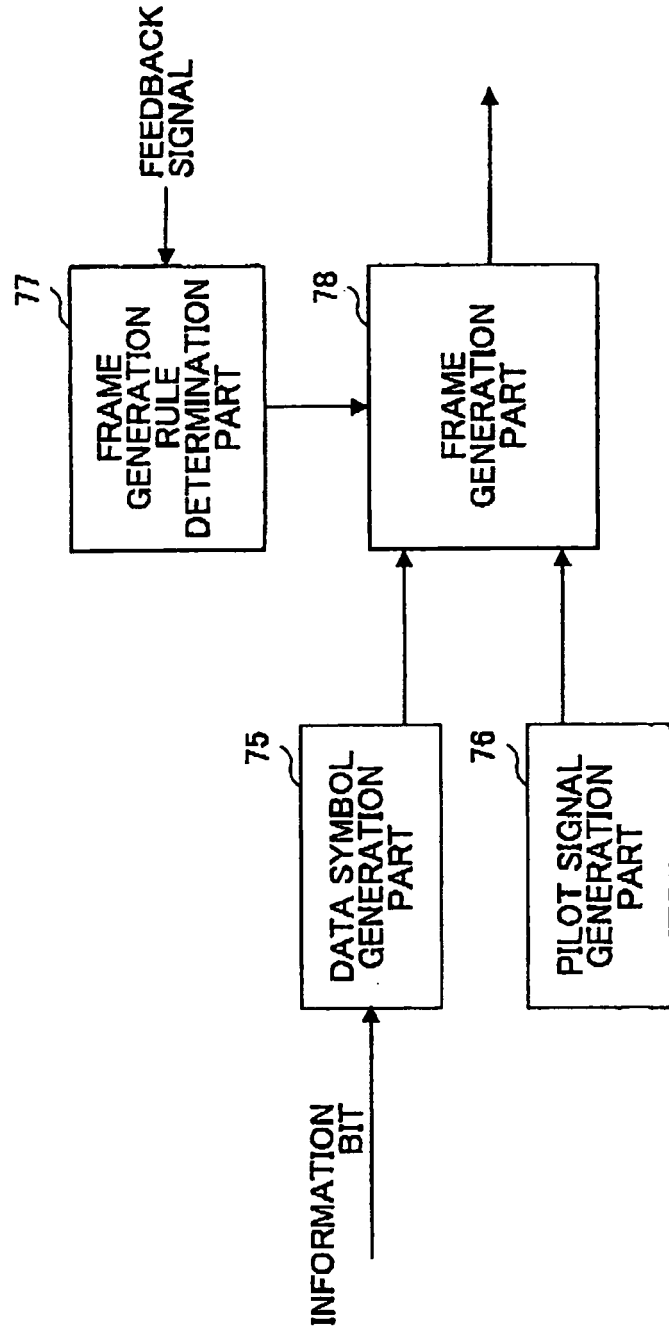
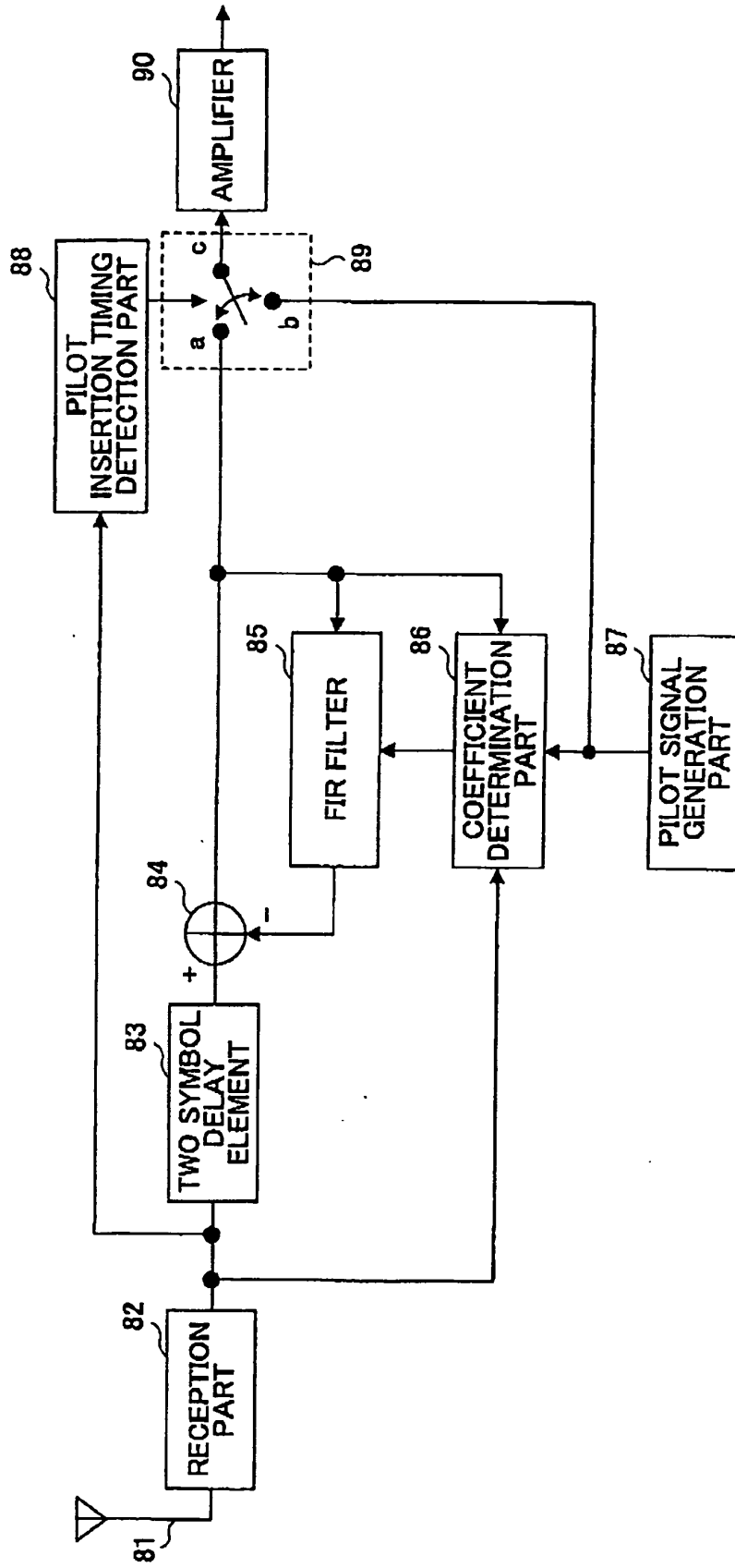

FIG. 10



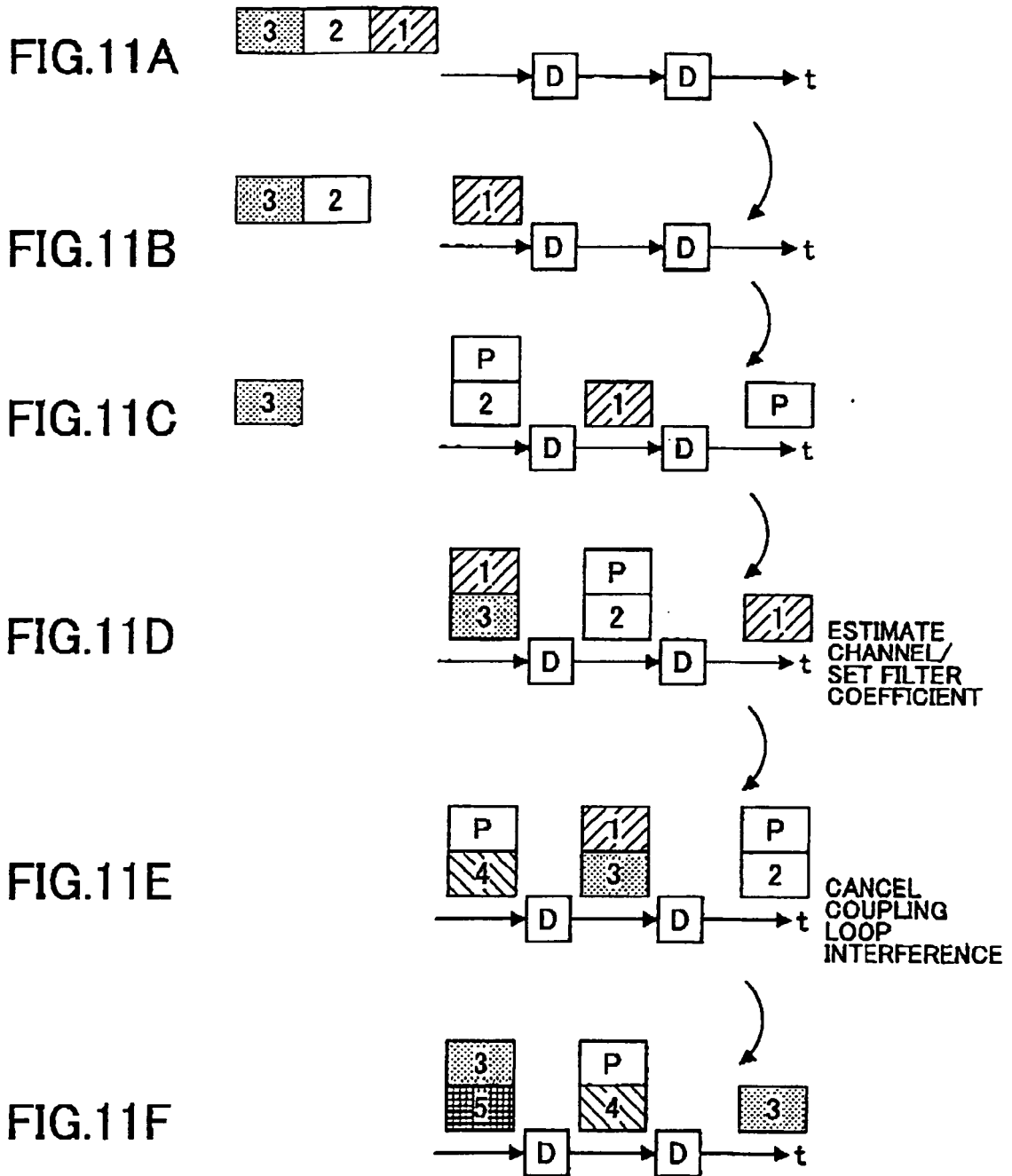

FIG.12

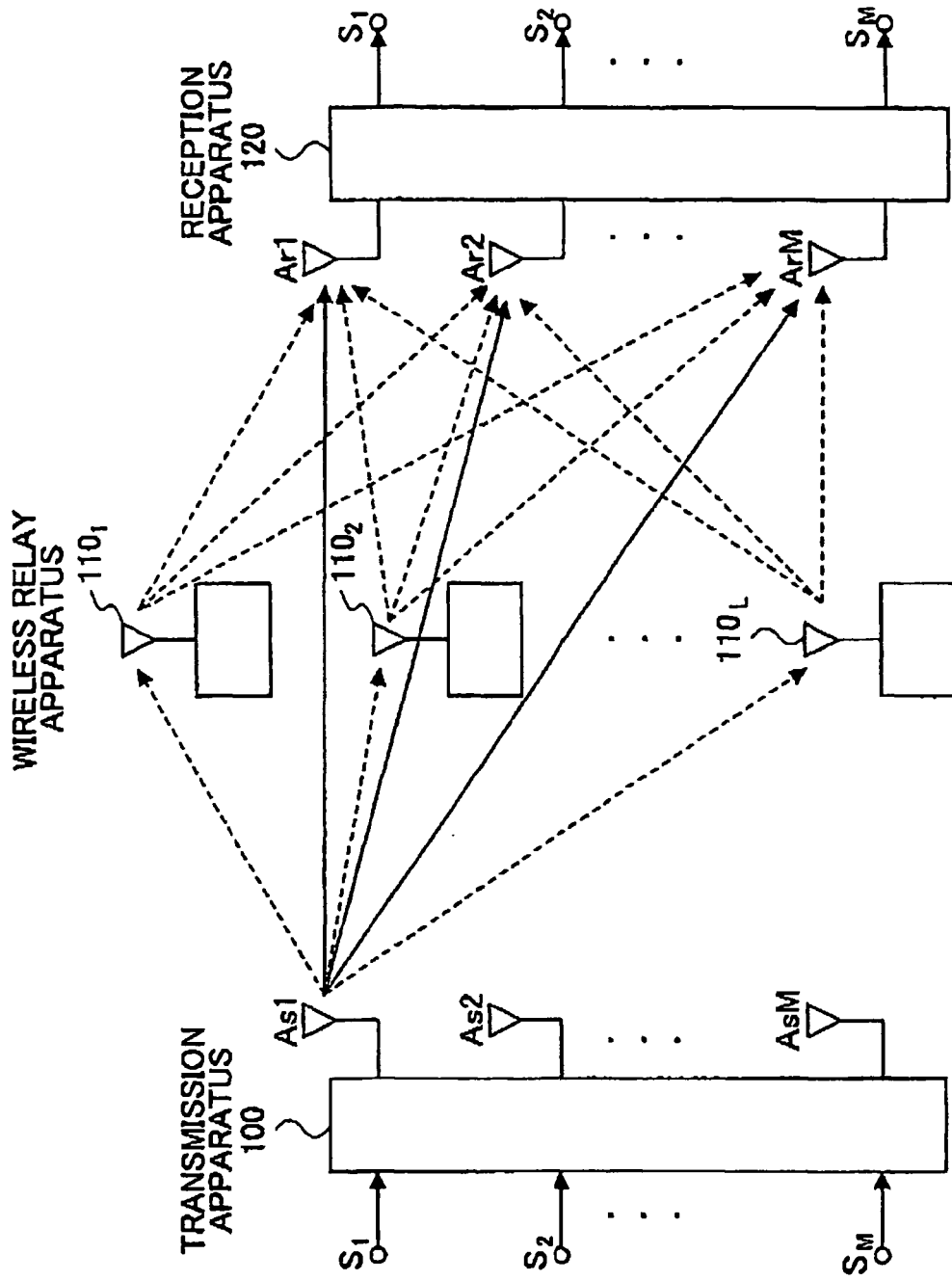
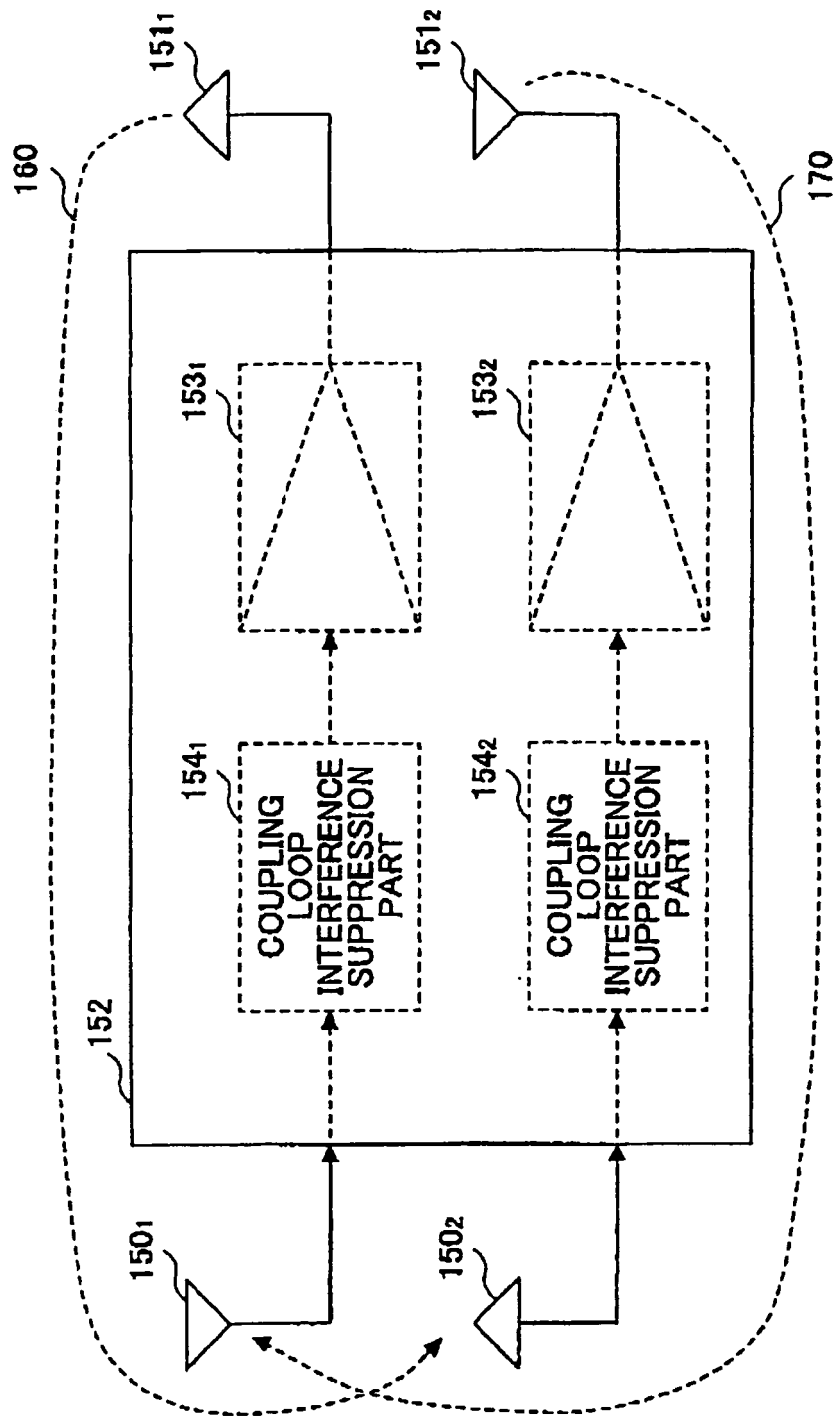

FIG.13



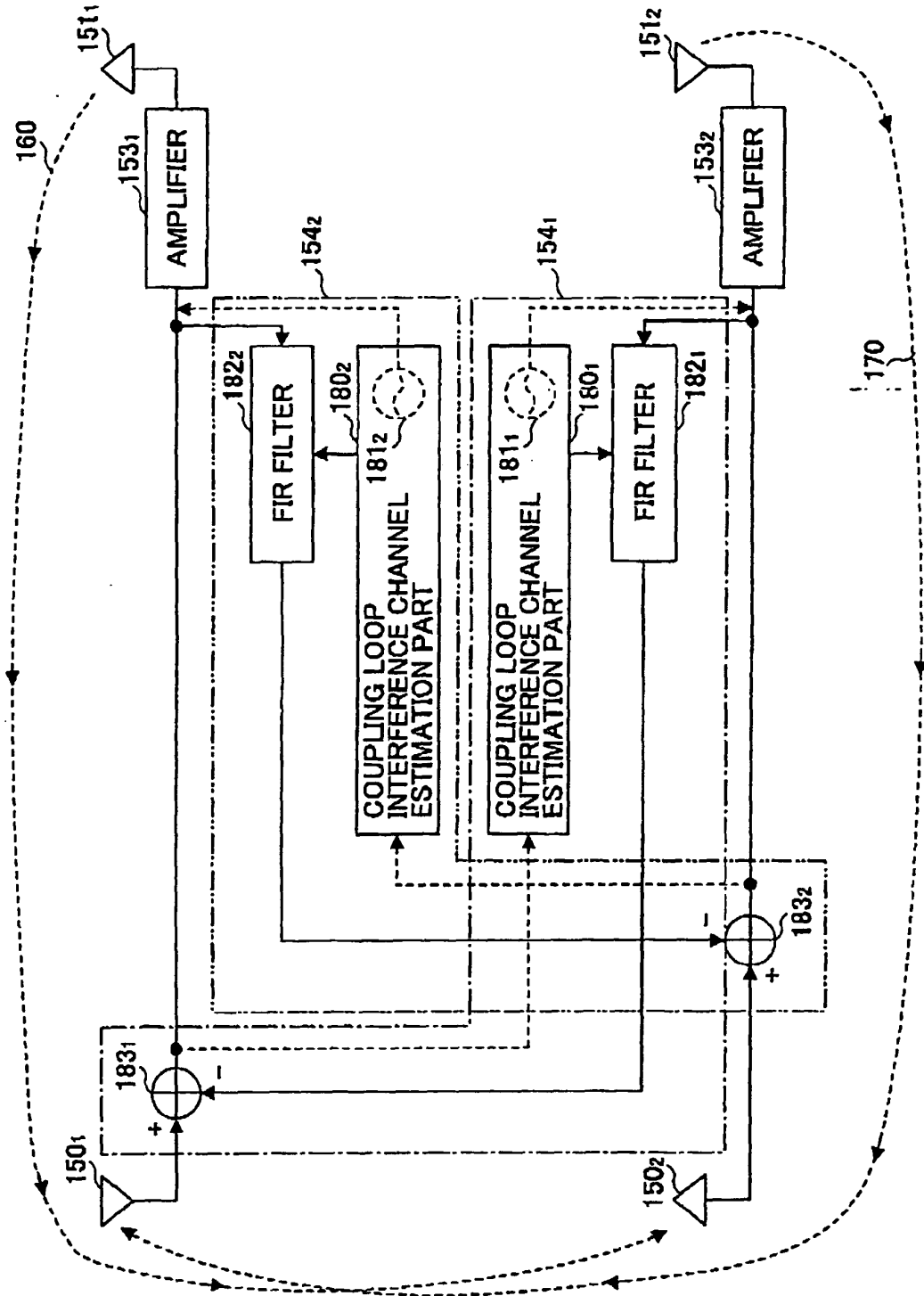
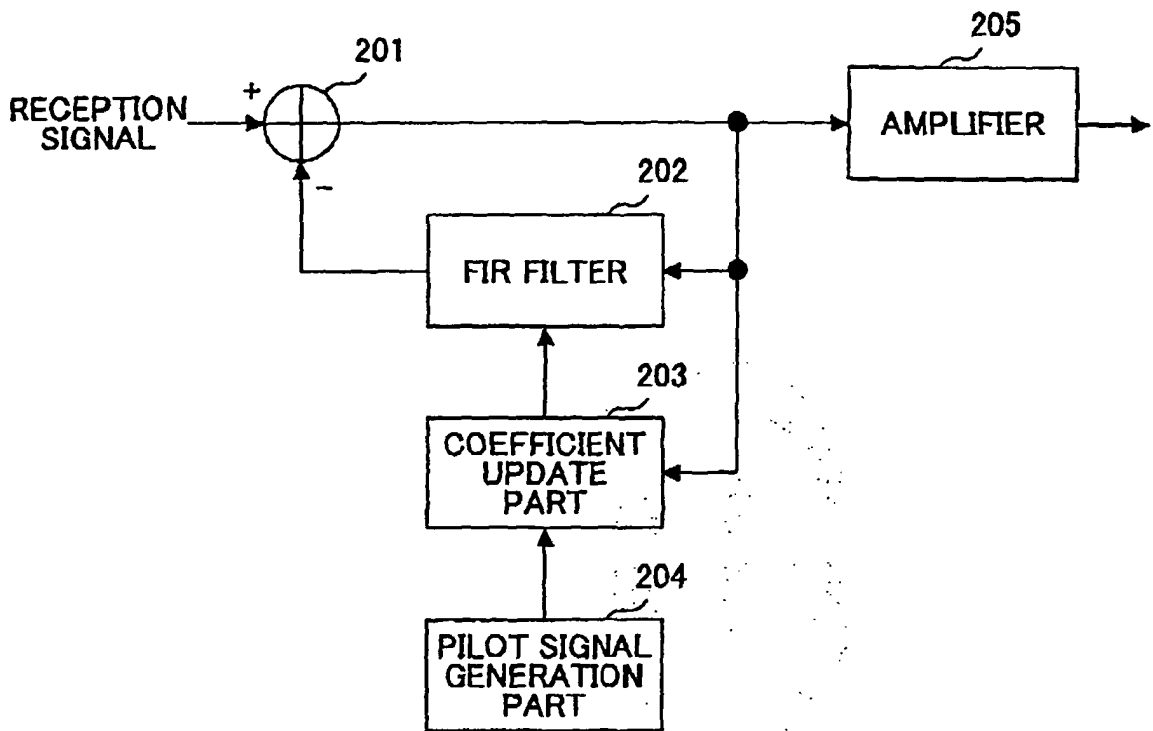

FIG.14

FIG.15



REFERENCES CITED IN THE DESCRIPTION

This list of references cited by the applicant is for the reader's convenience only. It does not form part of the European patent document. Even though great care has been taken in compiling the references, errors or omissions cannot be excluded and the EPO disclaims all liability in this regard.

Patent documents cited in the description

- JP 2003174392 A [0005] [0011]
- JP 2003298548 A [0005] [0006] [0012]
- JP 2001186073 A [0010] [0013]
- JP 8331016 A [0010] [0014]
- JP 2000244382 A [0010] [0015]
- EP 0851606 A [0016]