



US 20210074613A1

(19) **United States**

(12) **Patent Application Publication**

Eugene Lee et al.

(10) **Pub. No.: US 2021/0074613 A1**

(43) **Pub. Date: Mar. 11, 2021**

(54) **FLIPPABLE LEADFRAME FOR PACKAGED ELECTRONIC SYSTEM HAVING VERTICALLY STACKED CHIP AND COMPONENTS**

H01L 21/56 (2006.01)

H01L 21/78 (2006.01)

H01L 23/31 (2006.01)

H01L 51/56 (2006.01)

(71) Applicant: **TEXAS INSTRUMENTS INCORPORATED**, Dallas, TX (US)

(52) **U.S. Cl.**

CPC .. *H01L 23/49551* (2013.01); *H01L 23/49555*

(2013.01); *H01L 21/4842* (2013.01); *H01L*

21/565 (2013.01); *H01L 21/78* (2013.01);

H01L 23/49537 (2013.01); *H01L 23/49589*

(2013.01); *H01L 23/49568* (2013.01); *H01L*

23/49503 (2013.01); *H01L 51/56* (2013.01);

H01L 2224/97 (2013.01); *H01L 23/49586*

(2013.01); *H01L 23/3114* (2013.01)

(72) Inventors: **Lee Han Meng@ Eugene Lee**, Muar (MY); **Anis Fauzi Bin Abdul Aziz**, Melaka (MY); **Wei Fen, Sueann Lim**, Melaka (MY)

(21) Appl. No.: **16/953,189**

(22) Filed: **Nov. 19, 2020**

Related U.S. Application Data

(62) Division of application No. 15/287,561, filed on Oct. 6, 2016, now Pat. No. 10,879,154, which is a division of application No. 14/683,277, filed on Apr. 10, 2015, now Pat. No. 9,496,206.

Publication Classification

(51) **Int. Cl.**

H01L 23/495 (2006.01)

H01L 21/48 (2006.01)

(57)

ABSTRACT

A leadframe for electronic systems comprising a first sub-leadframe connected by links to a second sub-leadframe, the first and second sub-leadframe connected by tiebars to a frame; and each link having a neck suitable for bending the link, the necks arrayed in a line operable as the axis for bending the second sub-leadframe towards the first sub-leadframe with the necks operable as rotation pivots.

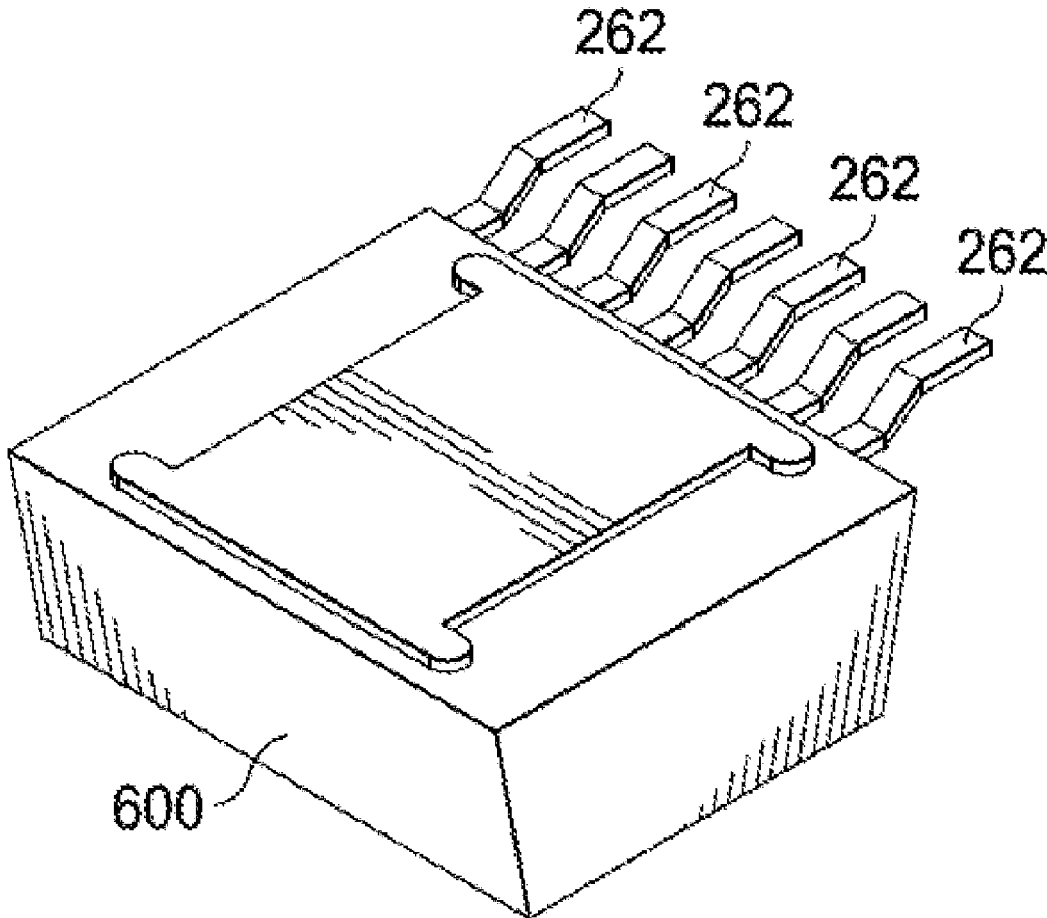

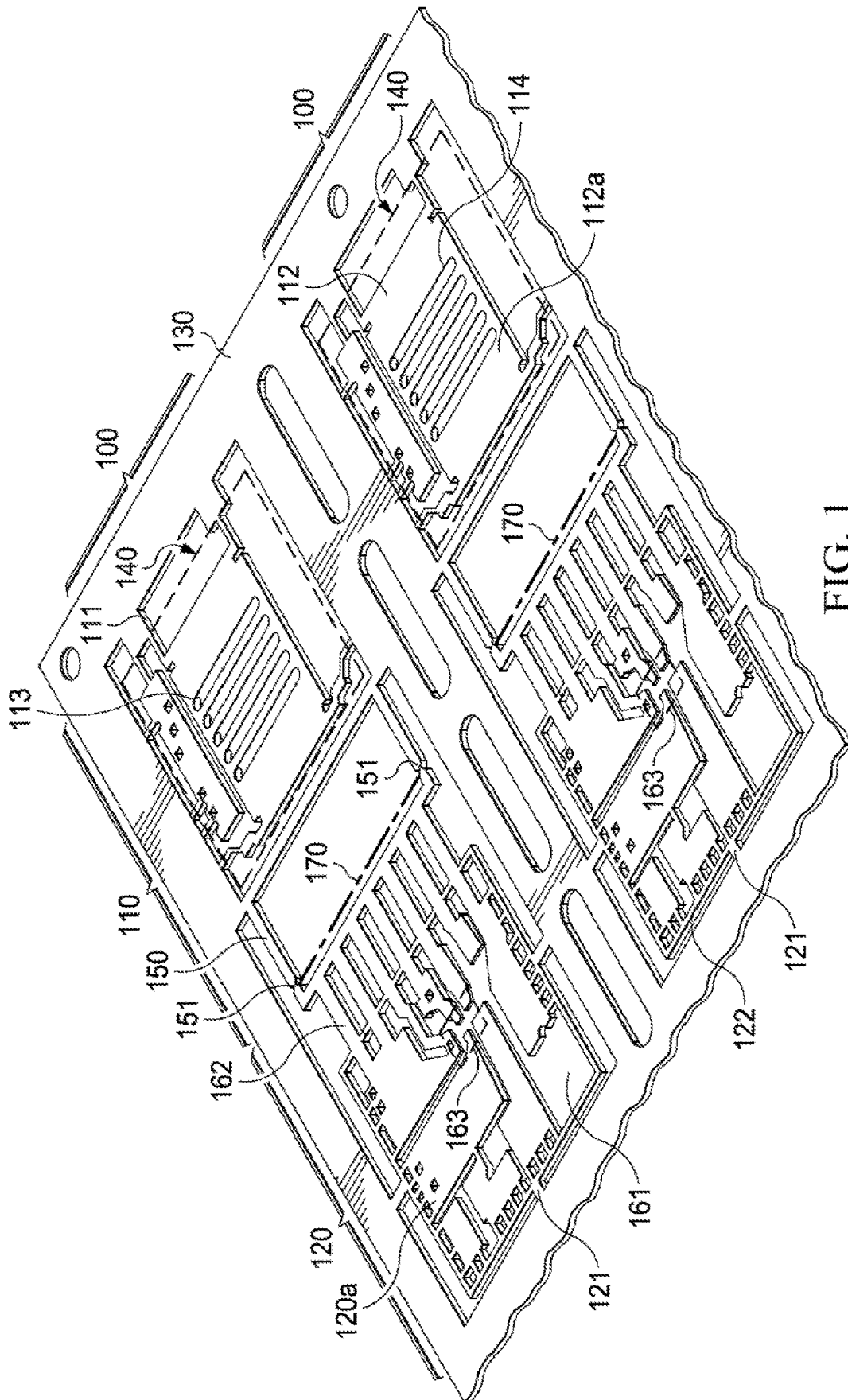

FIG. 1

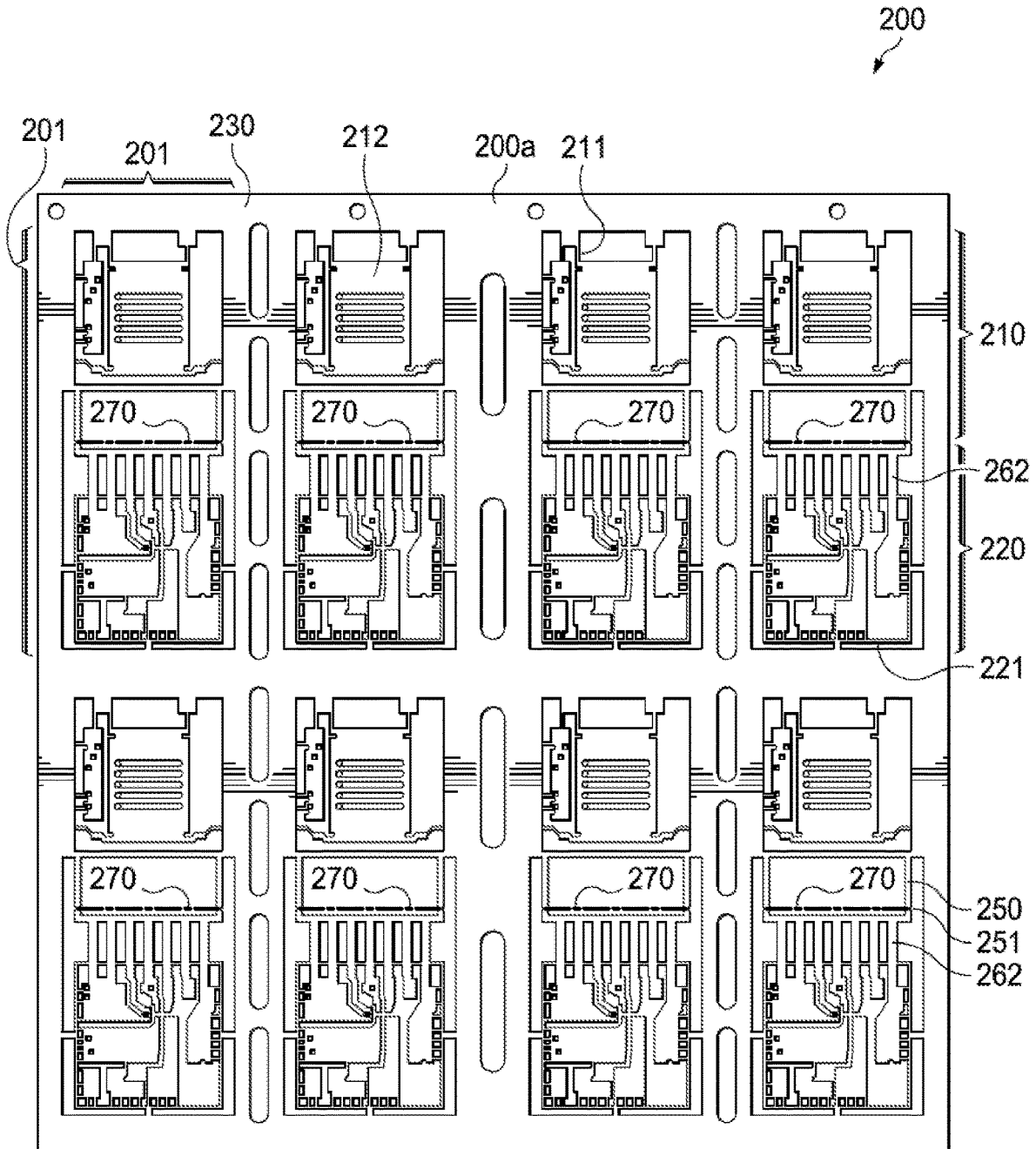

FIG. 2

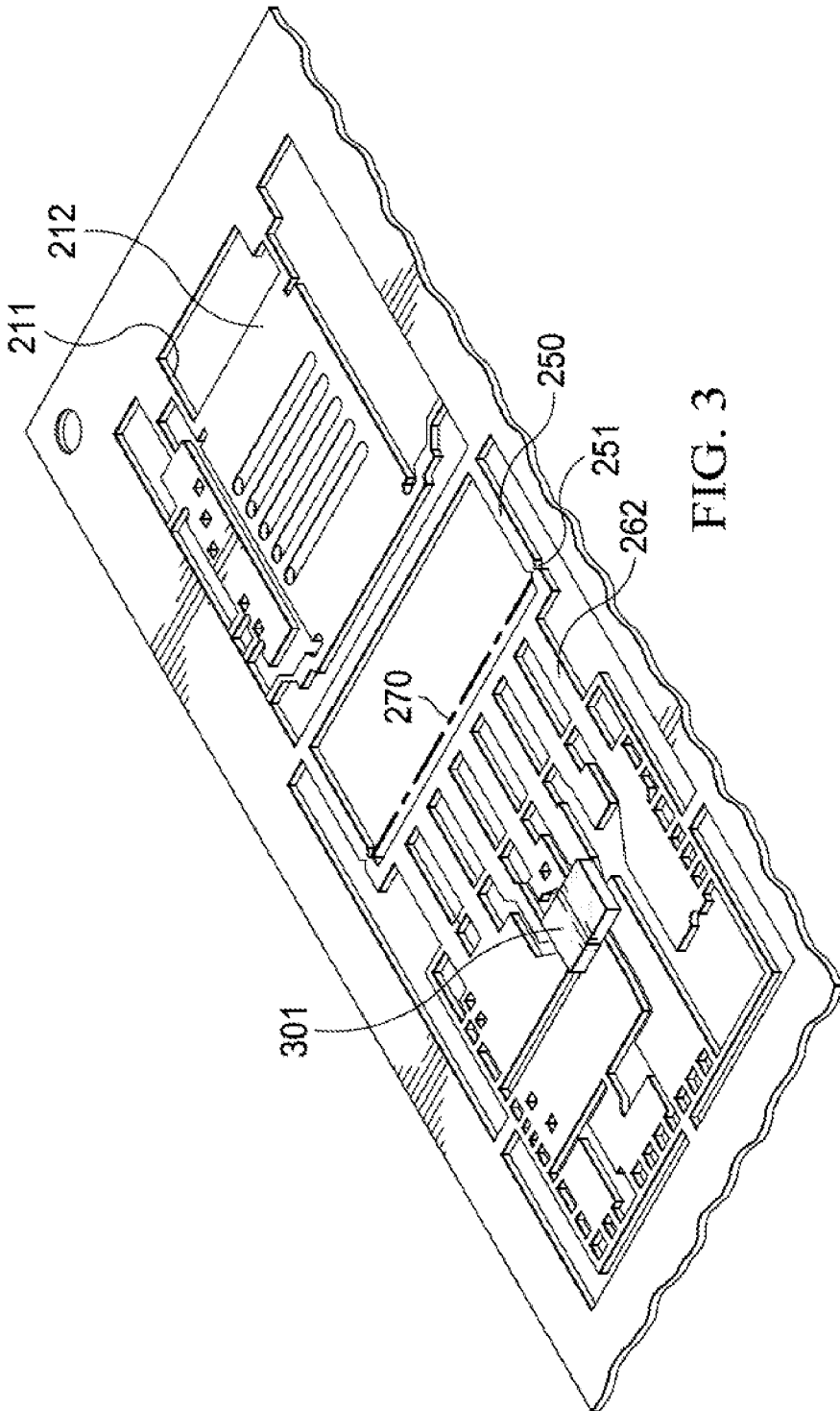

FIG. 3

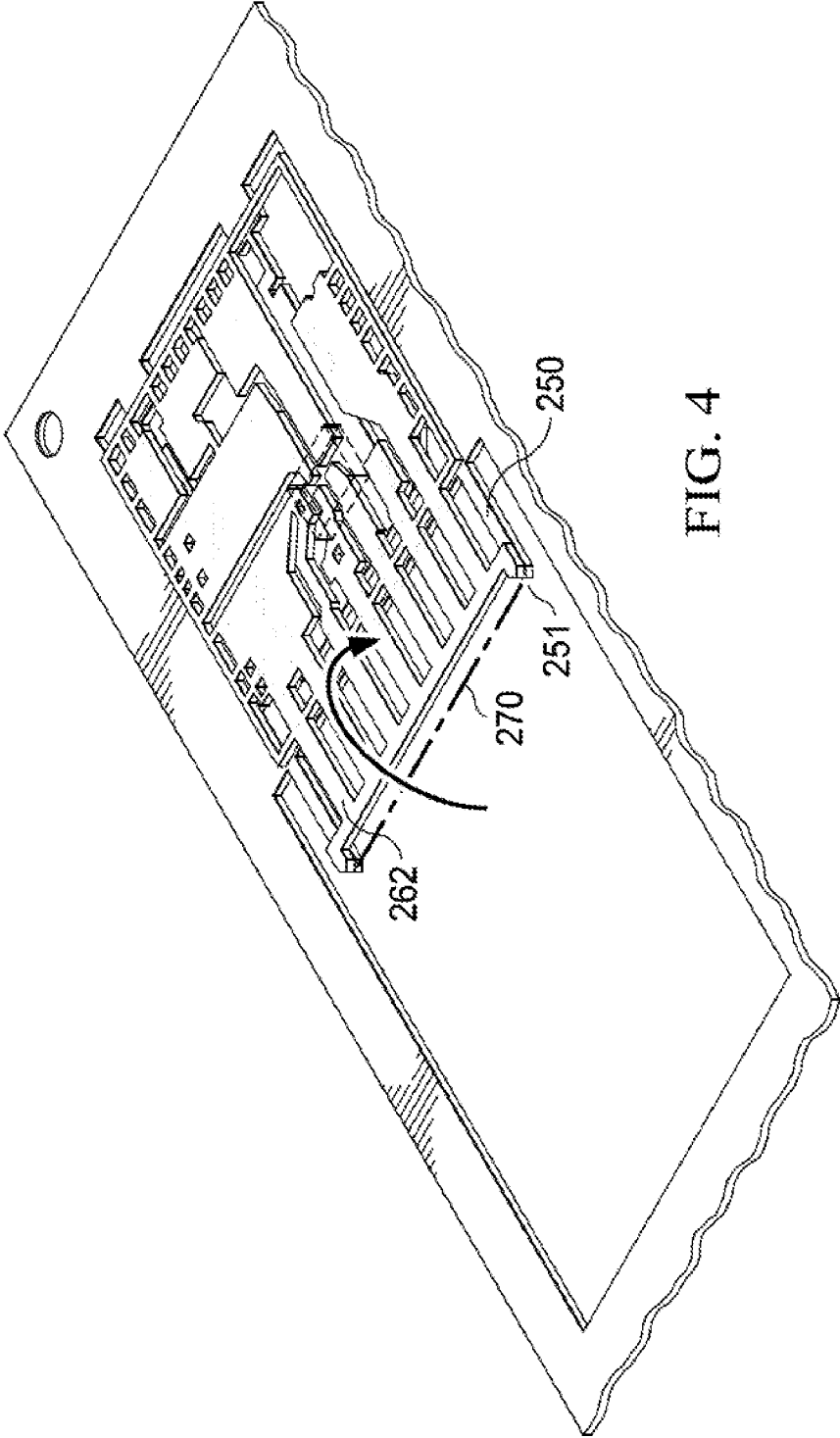

FIG. 4

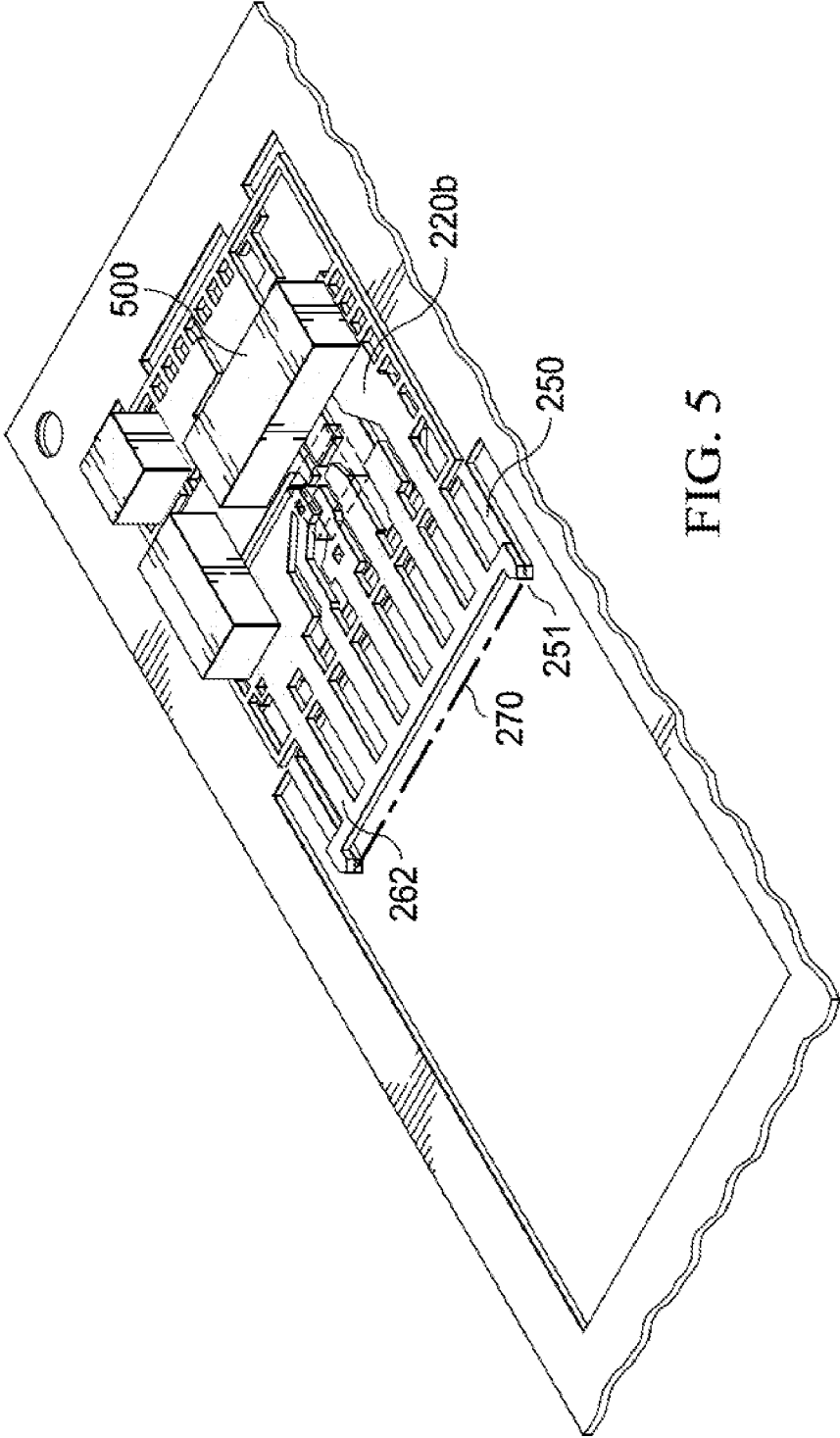

FIG. 5

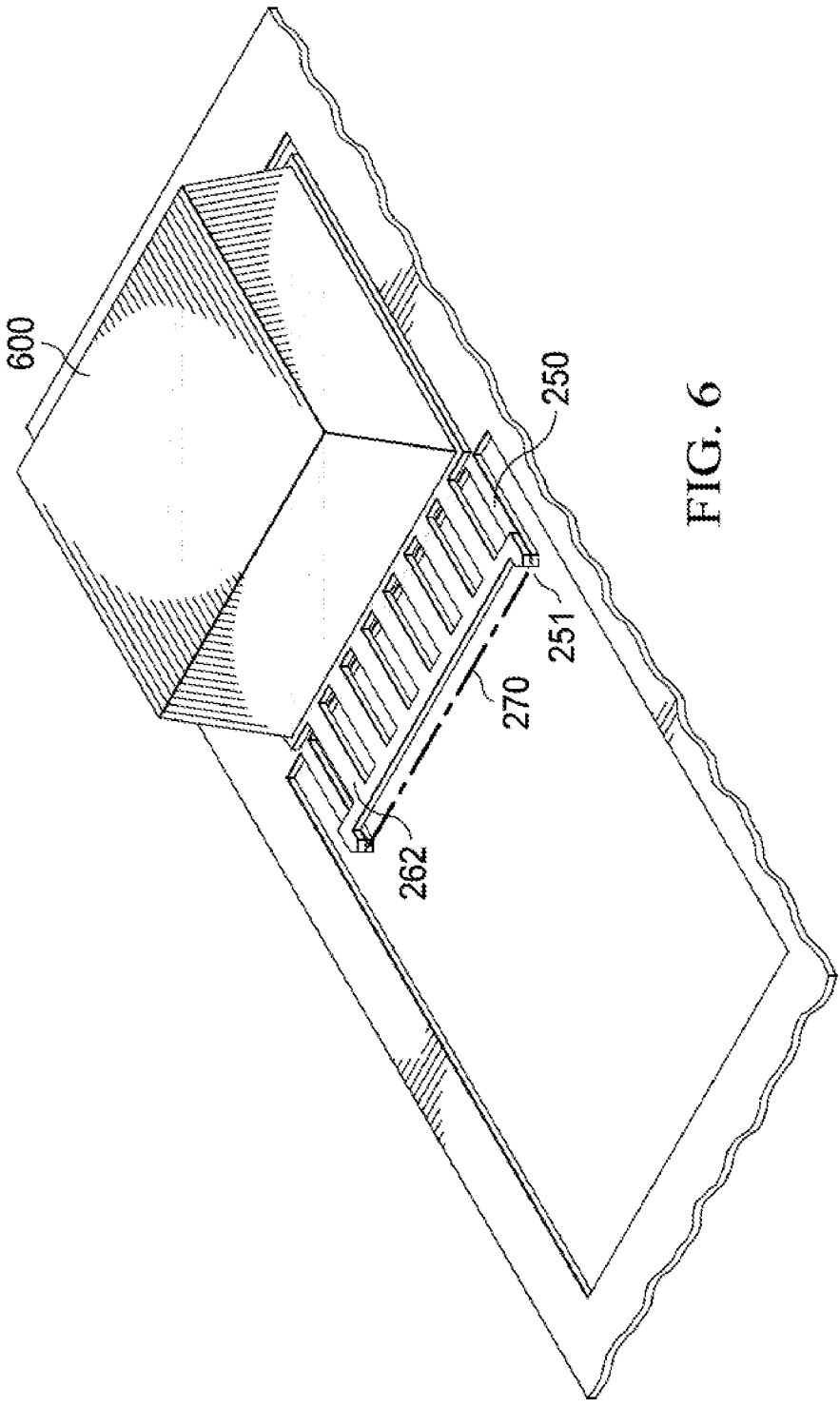

FIG. 6

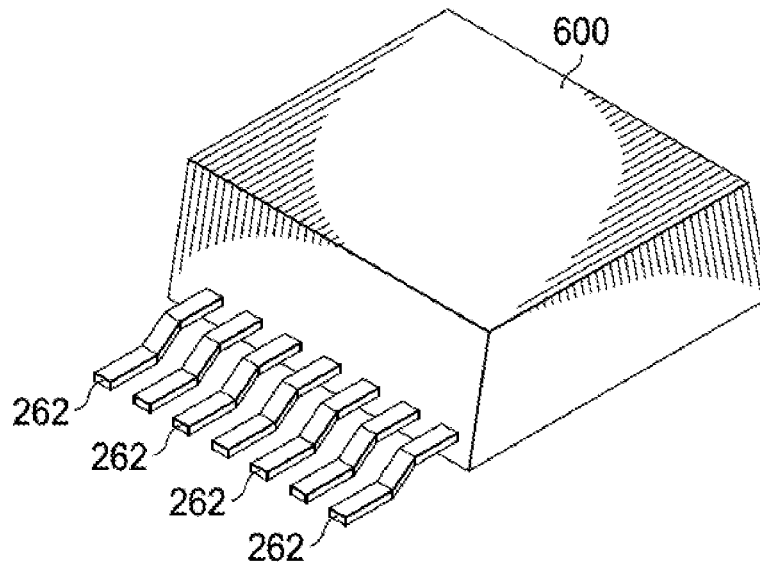

FIG. 7A

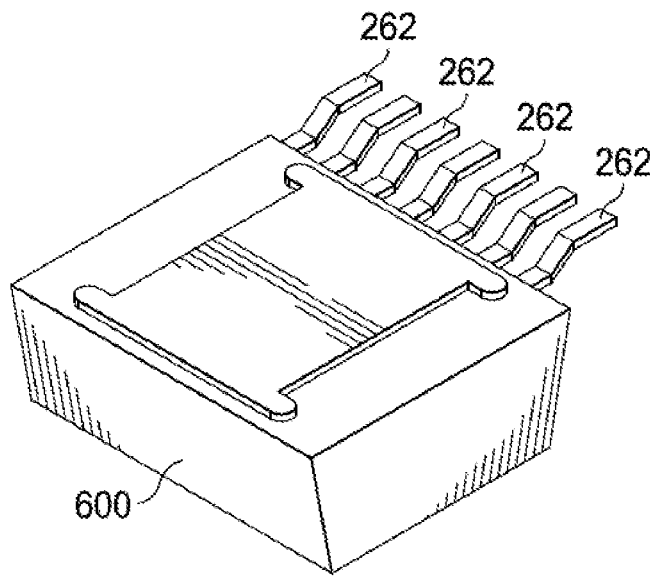

FIG. 7B

**FLIPPABLE LEADFRAME FOR PACKAGED
ELECTRONIC SYSTEM HAVING
VERTICALLY STACKED CHIP AND
COMPONENTS**

**CROSS-REFERENCE TO RELATED
APPLICATIONS**

[0001] This application is a Divisional of and claims priority to U.S. patent application Ser. No. 15/287,561 filed on Oct. 6, 2016 which is a Divisional of and claims priority to U.S. patent application Ser. No. 14/683,277 filed on Apr. 10, 2015, now U.S. Pat. No. 9,495,206 granted Oct. 13, 2016, which is incorporated herein by reference in its entirety.

FIELD

[0002] Embodiments of the invention are related in general to the field of semiconductor devices and processes, and more specifically to the structure and fabrication method of packaged electronic systems having a plurality of leadframes, vertically stacked by folding, together with semiconductor chips and passive components.

DESCRIPTION OF RELATED ART

[0003] Driven by the desire to reduce the board area needed to assemble a semiconductor device into electronic products such as hand-held telephones, today's semiconductor devices often use vertically stacked chips inside the packages. These chip stacks frequently include chips of significantly different sizes, assembled mostly by wire bonding techniques on interposers commonly made of rigid materials such as ceramics or fiber-enforced plastics such as FR-4 and others.

[0004] In applications where a whole system is to be encapsulated into a package, it is desirable to add passive components such as capacitors, resistors, and inductors to the stacked chips and incorporate the components into the package without unduly complicating the vertical stack. A frequently practiced solution for this integration, especially in power and converter systems, is the use of a first and a second metallic leadframe as a means for providing simultaneously the benefit for a significantly higher number of inputs/outputs, for freedom of choosing chips of different sizes and rerouting needs, for higher reliability based on reduced stress on the contact joints and on low-k dielectrics in the chips, and on reduced package warpage, and for reduced package thickness due to avoidance of wire bonding.

[0005] When the assembly of the system involves two leadframes sequentially, the process flow needs to pay attention to careful alignment of the second leadframe with the first leadframe—a process which involves a lot of manual handling and control of coplanarity. As an example, in some devices the first leadframe for signal connection involves a high number of leads connected to the chip terminals by a dense array of bonding wires; the signal connections are aligned along two opposite sides of the semiconductor chip. In addition, the power supply is provided by a second leadframe involving a low number of leads, but requiring broad geometry. The power leads are preferably attached by solder balls to the chip and require careful positioning along the remaining two chip sides.

SUMMARY

[0006] Applicants realized that in conventional semiconductor manufacturing, the advantage of using two leadframes on semiconductor devices with needs for high density stacking is frequently offset by the disadvantage of excessive manual handling, difficult alignments, and hard-to-control coplanarity. Difficulties of achieving compactness and avoiding misalignment and solder reflow limitations are compiled when passive components have to be merged in close proximity to active chips.

[0007] The problems of assembling two separate leadframes with the associate mating process have been solved when applicants discovered a methodology for constructing and processing a single leadframe, which combines both leadframes in an arrangement so that the second leadframe can be rotated and effortlessly aligned relative to the first leadframe.

[0008] In the new leadframe, a first sub-leadframe is connected by links to a second sub-leadframe so that each link has a neck suitable for bending the link. The necks of adjacent links are arrayed in a line operable as an axis for bending the second sub-leadframe towards the first sub-leadframe wherein the necks operable as rotation pivots.

[0009] For packaged electronic systems, the first sub-leadframe may include a pad suitable as substrate of an electronic system. The pad may have through-holes extending into grooves across the pad surface. In an encapsulation process, packaging material can be pressed through the through-holes and grooves in order to fill the space between the first and the folded second sub-leadframe with insulating material.

[0010] The second sub-leadframe may include leads having wide portions in an area approximately matching the area of the pad, and narrow portions outside the matched area. In the assembly process flow of an electronic system, the second sub-leadframe is folded at the bendable necks so that the second sub-leadframe is rotated around the axis until the second sub-leadframe is aligned on top of the first sub-leadframe and spaced from the first sub-leadframe by a gap. One or more semiconductor chips are disposed between the leads and the pad; and one or more passive components can be attached to the surface of the leads facing away from the chips.

[0011] The folded sub-leadframes, together with the attached passive components, can be encapsulated in a packaging compound.

BRIEF DESCRIPTION OF THE DRAWINGS

[0012] FIG. 1 illustrates the perspective view of a plurality of leadframes, each having a first and a second sub-leadframe connected by links having a neck suitable for bending the link according to the invention.

[0013] FIG. 2 shows a top view of a leadframe strip including a plurality of leadframes with first and second sub-leadframes.

[0014] FIG. 3 depicts a perspective view of a leadframe in the process of attaching a semiconductor chip onto the leads of the second sub-leadframe.

[0015] FIG. 4 illustrates the process of folding the second sub-leadframe at the bendable necks to rotate the second sub-leadframe around the axis formed by the aligned necks, until the second sub-leadframe is on top of the first sub-leadframe and spaced from it by a gap.

[0016] FIG. 5 shows the process of attaching passive components to the second sub-leadframe on the surface facing away from the first sub-leadframe.

[0017] FIG. 6 depicts the process of encapsulating the folded sub-leadframes together with the attached passive components in a packaging compound.

[0018] FIG. 7A illustrates a perspective top view of a discrete packaged system after the processes of trimming the first and second sub-leadframes and forming the un-encapsulated leads.

[0019] FIG. 7B depicts a perspective bottom view of a discrete packaged system.

DETAILED DESCRIPTION OF THE PREFERRED EMBODIMENTS

[0020] An exemplary embodiment of the invention is a leadframe as illustrated in FIG. 1 and generally designated 100. For cost-effective manufacturing and enabling batch-processing, it is practical to start with a leadframe strip 200 as shown in FIG. 2, which includes a plurality of leadframes 100. Leadframe strip 200 is stamped or etched from a flat sheet of metal selected from a group including copper, copper alloys, aluminum, iron-nickel alloys, and Kovar™. When the metal sheet is made of copper, the preferred thickness of the sheet is between 100 and 300 μm. For some applications, the sheet may be thicker or thinner. The metal sheet has a first surface and an opposite second surface. In FIGS. 1 and 2, the first surface is depicted and the opposite second surface is not shown. The metallurgical preparation of the second surface may be the same as the first surface, or it may be different. As an example, one surface, or at least a portion of the surface, may be prepared for facilitating solder attachment; or may be prepared for enhancing adhesion to polymeric compounds.

[0021] Generally, leadframe 100 is intended for an electronic system. The system may include at least one active semiconductor chip and one or more passive components. Consequently, the leadframe feature include elements for assembling and supporting semiconductor chips and for assembling and supporting component, as well as interconnecting leads within the leadframe and to external parts, and supporting rails for stability and handling.

[0022] Referring now to the embodiment of FIG. 1, each leadframe 100 comprises two sub-leadframes 110 and 120. Herein, sub-leadframe 110 is called first sub-leadframe, and sub-leadframe 120 is called second sub-leadframe. FIG. 1 indicates that first sub-leadframe 110 and second sub-leadframe 120 are connected by tiebars 111 and 121, respectively, to frame 130. Especially tiebars 121 are mechanically weak to allow an easy trimming process. In addition, sub-leadframe 120 is surrounded by dambars 122 for encapsulation control. For explanatory purpose, FIG. 1 includes the outline of the encapsulating package of the finished product.

[0023] As FIG. 1 illustrates, first sub-leadframe 110 is connected to second sub-leadframe 120 by a couple of links 150; in other embodiments, there may be more than two links. Each link 150 has a narrow neck 151, which is suitable for allowing easy bending of the link. The plurality (or more) of necks of adjacent links is arrayed in a line 170, which is operable as the axis for bending the second sub-leadframe 120 towards the first sub-leadframe 110 in the assembly process described below, whereby the necks 151 operate as rotation pivots.

[0024] For the electronic system realized by the exemplary embodiment of FIG. 1, first sub-leadframe 110 includes a pad 112 suitable as substrate of the electronic system. FIG. 1 shows the first surface 112a of pad 112. For the purposes of electrically grounding the system and of dissipating the operational heat, pad 112 is preferably intended to be exposed from the encapsulating package. Consequently, second surface 112b (not shown in FIG. 1) has a metallurgical configuration to enhance solderability, such as a surface layer of nickel followed by a layer of palladium (and a layer of gold).

[0025] In FIG. 1, pad 112 further includes through-holes 113, which extend into elongated grooves 114 across first surface 112a. The through-holes and the grooves are suitable for channeling a viscous encapsulation compound. In the encapsulation process (see below), the semi-liquid encapsulation compound is pressured from surface 112b through the holes 113 to surface 112a, where the compound can form an insulating layer between the folded first and second sub-leadframes.

[0026] For the electronic system realized in the exemplary embodiment of FIG. 1, second sub-leadframe 120 includes a set of leads, which have wide portions 161 in an area outlined by dashed lines 140, and narrow portions 162 outside the matched area. The area of the wide portion 161 may substantially coincide with the area of pad 112 of the first sub-leadframe. It may be advantageous for the assembly of some embodiments, when some spots 163 of the wide lead portions 161 have recesses relative to first surface 120a; such recesses may facilitate the attachment of semiconductor chip terminals, preferably with the help of solder balls. Sometimes these recesses 163 are referred to as first recesses. In addition, the wide portions of some leads may have recesses relative to the second surface (not shown in FIG. 1; see however FIGS. 4 and 5); such recess may facilitate the attachment of passive components. Sometimes these recesses are referred to as second recesses. Furthermore, it may be advantageous for assembling electronic systems when the first and the second recesses of the wide lead portions have a metallurgical configuration suitable for solder attachment.

[0027] Another embodiment of the invention is a method for assembling an electronic system. The method starts by the process of providing a leadframe strip, such as exemplary strip 200 of FIG. 2. The strip has a first surface 200a and an opposite second surface (not shown in FIG. 2). The strip includes a plurality of assembly sites 201. Each site 201 includes a leadframe 230, which holds a pair of sub-leadframes 210 and 220 by tiebars 211 and 221, respectively.

[0028] First sub-leadframe 210 is connected by links 250 to second sub-leadframe 220. Each link 250 of the pair has a neck 251 suitable for bending the link. The necks 251 of adjacent links are arrayed in a line 270 operable as the axis for bending the second sub-leadframe 220 towards the first sub-leadframe 210 with the necks 251 operable as rotation pivots.

[0029] The exemplary leadframes depicted in strip 200 of FIG. 2 are for an exemplary electronic system analogous to the system described in FIG. 1. Thus, the structure of the first sub-leadframe 210 includes a pad 212 suitable as substrate of the electronic system. As mentioned above, it may be advantageous for many systems that pad 212 includes through-holes, which extend into elongated grooves across the first surface of the pad. These through-holes and the

grooves are suitable for channeling a viscous encapsulation compound so that an insulating layer between the folded first and second sub-leadframes can be formed.

[0030] The second sub-leadframe **220** includes leads with wide portions **261** of various configurations in an area approximately matching the area of pad **212**, and narrow portions **262** outside the matched area; after the packaging process, the narrow lead portions are operable to connect the packaged system to external parts.

[0031] The next process is indicated in FIG. **3**. A semiconductor chip **301** with terminals is selected. The terminals are connected to the first surface of spots of leads **261**, which belong to the wide portion of the leads. These spots may have a suitable recess or a specific metallurgy, such as an enhanced affinity to solder attachment (for example thin layers of nickel and palladium), which facilitates the connection to the chip terminals.

[0032] In the next process, shown in FIG. **4**, the tiebars **221**, which connect sub-leadframe **220** to frame **230**, are trimmed so that sub-leadframe **230** becomes movable. Then, the second sub-leadframe **220** is folded at the bendable necks **251** in order to rotate the second sub-leadframe around the axis constituted by the line **270** running through the necks of adjacent links, until second sub-leadframe **220** is aligned on top of first sub-leadframe **210**. In this aligned position, second sub-leadframe **220** is spaced from first sub-leadframe **210** by a gap, while the side of semiconductor chip **301** opposite the attached chip terminals touches the first surface of pad **212**. In FIG. **4**, the second surface of sub-leadframe **220** is visible and is therefore obscuring the view of the gap and chip **301** disposed between the first and second sub-leadframes.

[0033] FIG. **5** illustrates the next process of attaching one or more discrete components **500** onto the second surface **220b** of the second sub-leadframe. The attachment process can be facilitated when the second surface **220b** has recesses for the components, and when the recesses further have a surface metallurgy enhancing solder adhesion. For copper leadframes, an example is offered by thin layers of nickel, palladium, and gold.

[0034] The next procedure, shown in FIG. **6**, is the process of encapsulating the folded sub-leadframes **210** and **220** together with the attached passive components in a packaging compound **600**. However, the narrow portions **262** of the leads are left un-encapsulated. A preferred process is the transfer molding of an epoxy-based polymeric packaging compound. During the encapsulation process the packaging compound propagates through any through-hole and groove of the pad in order to fill the gap between the first and the second sub-leadframe; in this process, an insulating layer is formed between the first and second sub-leadframe, except for the chip disposed between the first and second sub-leadframe.

[0035] In the next process, depicted in FIGS. **7A** and **7B**, the first and second sub-leadframes are trimmed, and concurrently the un-encapsulated leads are formed. Subsequently, the strip is singulated into discrete packaged electronic systems. FIG. **7A** shows a discrete packaged system in perspective top view, and FIG. **7B** in perspective bottom view, displaying the second surface of the pad **212** of the first sub-leadframe. Preferably, the second pad surface has a metallurgical configuration for facilitating solder attachment to boards and external parts.

[0036] Another embodiment of the invention is a packaged electronic system based on a metallic leadframe. An exemplary embodiment includes a vertical stack, which includes a second sub-leadframe aligned over and insulated from a first sub-leadframe, at least one semiconductor chip disposed between the first and second sub-leadframe, and one or more on top of the second sub-leadframe. In this exemplary system, the first sub-leadframe has a pad suitable to operate as the substrate of the system; as the system substrate, the second surface of the pad preferably has the metallurgical configuration to be solderable to external boards. The second sub-leadframe has leads with narrow and wide portions; preferably, the wide portions have first recesses facing the pad and second recesses facing away from the pad, wherein the recesses preferably have a metallurgical configuration to be solderable. Other systems may use flat leads shaped like in QFN (Quad Flat No-Lead) and SON (Small Outline No-Lead) devices.

[0037] The at least one chip of the exemplary system is disposed in the space between the first recesses and the pad. The remainder of the space between first and second sub-leadframe is filled with insulating material. A preferred method of filling the space uses a plurality of holes through the pad to allow ingress of insulating compound during the encapsulation process; the holes feed into an array of grooves across the pad surface so that the compound can spread from the grooves to fill the available space. Discrete components are attached to the second recesses. Topping the vertical stack, the components are in close proximity to the chips, minimizing parasitic resistances and inductances whereby they top the second sub-leadframe. The components may include resistors, capacitors, and inductances.

[0038] While this invention has been described in reference to illustrative embodiments, this description is not intended to be construed in a limiting sense. Various modifications and combinations of the illustrative embodiments, as well as other embodiments of the invention, will be apparent to persons skilled in the art upon reference to the description. As an example, the invention applies not only to active semiconductor devices with low and high pin counts, such as transistors and integrated circuits, but also to combinations of active and passive components on a leadframe pad.

[0039] As another example, the invention applies not only to silicon-based semiconductor devices, but also to devices using gallium arsenide, gallium nitride, silicon germanium, and any other semiconductor material employed in industry.

[0040] It is therefore intended that the appended claims encompass any such modifications or embodiments.

We claim:

1. A leadframe for electronic systems comprising:
 - a first sub-leadframe connected by links to a second sub-leadframe, the first and second sub-leadframe connected by tiebars to a frame; and
 - each link having a neck suitable for bending the link, the necks arrayed in a line operable as the axis for bending the second sub-leadframe towards the first sub-leadframe with the necks operable as rotation pivots.
2. The leadframe of claim **1** wherein the first and second sub-leadframes and the frame are cut from a flat metal sheet having a first surface and an opposite second surface.
3. The leadframe of claim **2** wherein the first sub-leadframe includes a pad suitable as substrate of the electronic system.

4. The leadframe of claim 3 wherein the pad further includes through-holes extending into elongated grooves across the first surface, the through-holes and the grooves suitable for channeling a viscous encapsulation compound.

5. The leadframe of claim 3 wherein the second sub-leadframe includes a set of leads having wide portions in an area approximately matching the area of the pad, and narrow portions outside the matched area.

6. The leadframe of claim 5 wherein the wide portions of the leads have first recesses in the first surface and second recesses in the second surface.

7. The leadframe of claim 6 wherein the first and the second recesses of the leads have a metallurgical configuration suitable for solder attachment.

* * * * *