



US007520554B2

(12) **United States Patent**
Brown et al.

(10) **Patent No.:** **US 7,520,554 B2**
(45) **Date of Patent:** **Apr. 21, 2009**

(54) **SEAT CONFIGURATION SYSTEM FOR AN AUTOMOTIVE INTERIOR**

(75) Inventors: **Gregory Philip Brown**, Dearborn, MI (US); **Warren Nally**, South Lyon, MI (US); **Thomas Green**, Farmington, MI (US)

(73) Assignee: **Ford Global Technologies, LLC**, Dearborn, MI (US)

(*) Notice: Subject to any disclaimer, the term of this patent is extended or adjusted under 35 U.S.C. 154(b) by 0 days.

1,306,498 A *	6/1919	Moses	296/64
1,443,479 A	1/1923	Lambert	
1,644,528 A	10/1927	Huff	
2,007,471 A *	7/1935	Landgrebe	297/94
2,979,098 A	4/1961	Greaves	
3,165,350 A	1/1965	Willson	
3,785,325 A *	1/1974	Mycroft	440/12.57
4,168,860 A	9/1979	Garza et al.	
4,341,415 A *	7/1982	Braun et al.	296/64
4,407,542 A	10/1983	Kehl et al.	
4,468,051 A *	8/1984	Kobayashi	280/751
4,487,452 A	12/1984	Tanizaki et al.	
4,585,273 A	4/1986	Higgs et al.	

(21) Appl. No.: **11/865,182**

(22) Filed: **Oct. 1, 2007**

(65) **Prior Publication Data**

US 2008/0018151 A1 Jan. 24, 2008

Related U.S. Application Data

(62) Division of application No. 10/709,403, filed on May 3, 2004, now Pat. No. 7,281,761.

(51) **Int. Cl.**

B60N 2/02 (2006.01)

A47B 83/02 (2006.01)

(52) **U.S. Cl.** **296/65.01**; 296/68.1; 297/94; 297/157.1

(58) **Field of Classification Search** 296/64, 296/65.01, 68.1, 65.06; 297/94, 95, 157.1, 297/257, 243, 283.1, 283.3, 92, 93, 96-104, 297/283.2, 188.04

See application file for complete search history.

(56) **References Cited**

U.S. PATENT DOCUMENTS

505,246 A	9/1893	Hale
629,258 A	7/1899	Johnston
923,197 A	6/1909	Murchison
1,096,678 A	5/1914	Budd

(Continued)

FOREIGN PATENT DOCUMENTS

JP 57041234 A * 3/1982

(Continued)

Primary Examiner—Milton Nelson, Jr.

(74) *Attorney, Agent, or Firm*—Gregory Brown; Brooks Kushman P.C.

(57) **ABSTRACT**

A unique and versatile seating system for automobiles is provided. The seating system includes aspects to improve the functionality of the seating arrangement while maintaining the safety and comfort of the automotive seats. In certain embodiments, the seating system includes a reversible automotive seat that includes a seat cushion and a backrest. The backrest is movable between a forward seating position and a rearward seating position and includes an integrated restraint system which is operable to secure an occupant seated when the backrest is in either the forward or rearward seating positions.

21 Claims, 21 Drawing Sheets

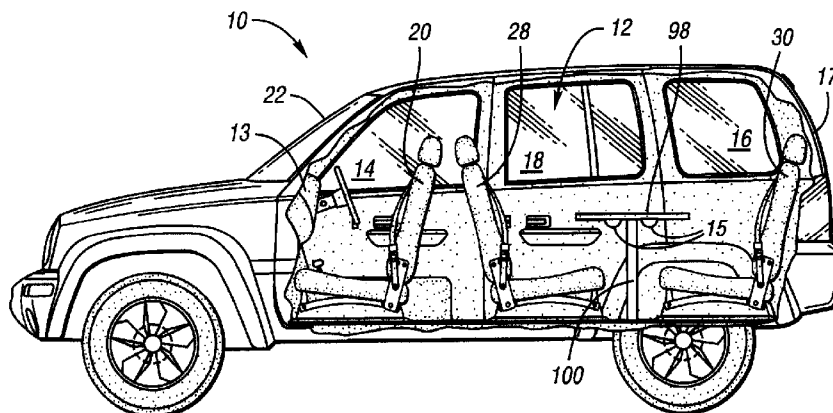

U.S. PATENT DOCUMENTS

4,592,588 A 6/1986 Isono et al.
 4,655,503 A 4/1987 Kamijo et al.
 4,668,010 A 5/1987 Fujiwara
 4,685,719 A 8/1987 Hanemaayer
 4,779,917 A 10/1988 Campbell et al.
 4,792,188 A 12/1988 Kawashima
 5,000,505 A 3/1991 Kawashita et al.
 5,046,433 A 9/1991 Kramer et al.
 5,056,849 A * 10/1991 Norris et al. 296/65.05
 5,149,171 A 9/1992 Gilevich et al.
 5,197,774 A 3/1993 Diaz
 5,322,341 A * 6/1994 Harrison et al. 297/94
 5,451,009 A 9/1995 Rumpf
 5,482,354 A 1/1996 Gryp
 5,524,962 A 6/1996 Fulgenzi et al.
 5,611,589 A * 3/1997 Fujii et al. 296/64
 5,639,141 A 6/1997 Hanemaayer
 5,720,515 A * 2/1998 Haffner 297/188.04
 5,947,541 A 9/1999 Behrens et al.
 5,967,608 A 10/1999 Van Sickle
 6,000,742 A 12/1999 Schaefer et al.
 D419,520 S 1/2000 Bergh
 6,017,074 A * 1/2000 Biskup 296/39.1

6,065,798 A 5/2000 Sankrithi
 6,079,773 A 6/2000 Hassan
 D430,534 S 9/2000 Golenz
 6,126,218 A 10/2000 Karhumaki
 6,129,404 A 10/2000 Mattarella et al.
 6,168,234 B1 1/2001 Haynes et al.
 6,199,945 B1 3/2001 Kim
 6,315,352 B1 11/2001 Nomura
 6,402,246 B1 6/2002 Mundell
 6,439,443 B1 8/2002 Liao
 6,457,694 B1 10/2002 Haynes et al.
 6,471,297 B1 10/2002 Runde et al.
 6,474,739 B1 11/2002 Lagerweij
 6,474,741 B2 11/2002 Kamida et al.
 6,488,333 B2 12/2002 Kim
 6,494,531 B1 12/2002 Kim
 6,575,420 B2 6/2003 Yoshida et al.
 6,715,825 B2 4/2004 Tame
 6,957,853 B2 * 10/2005 Williams et al. 297/93

FOREIGN PATENT DOCUMENTS

WO 0214103 A1 2/2002

* cited by examiner

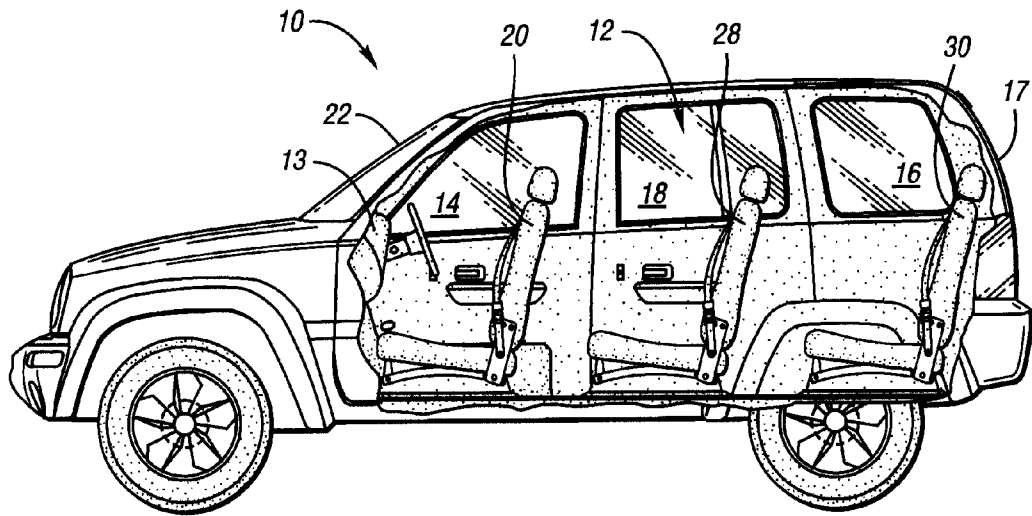

Fig. 1a

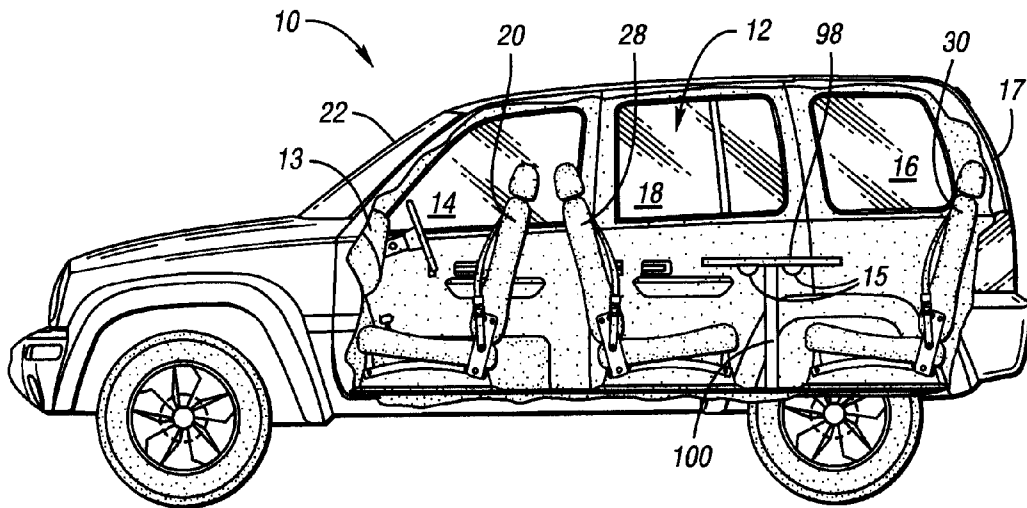

Fig. 1b

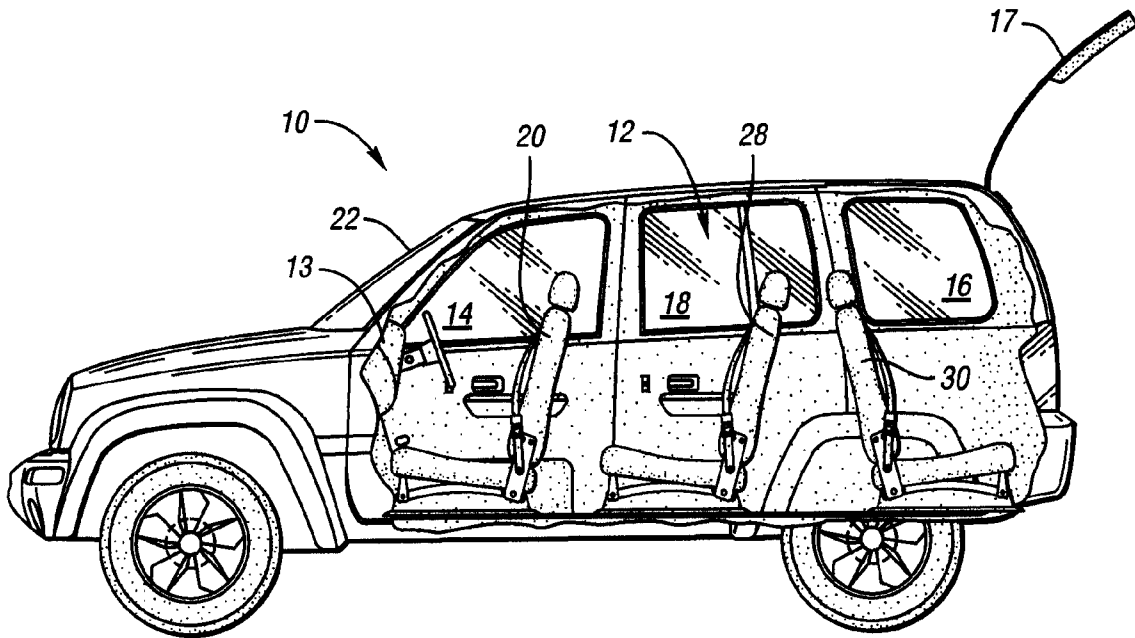

Fig. 1c

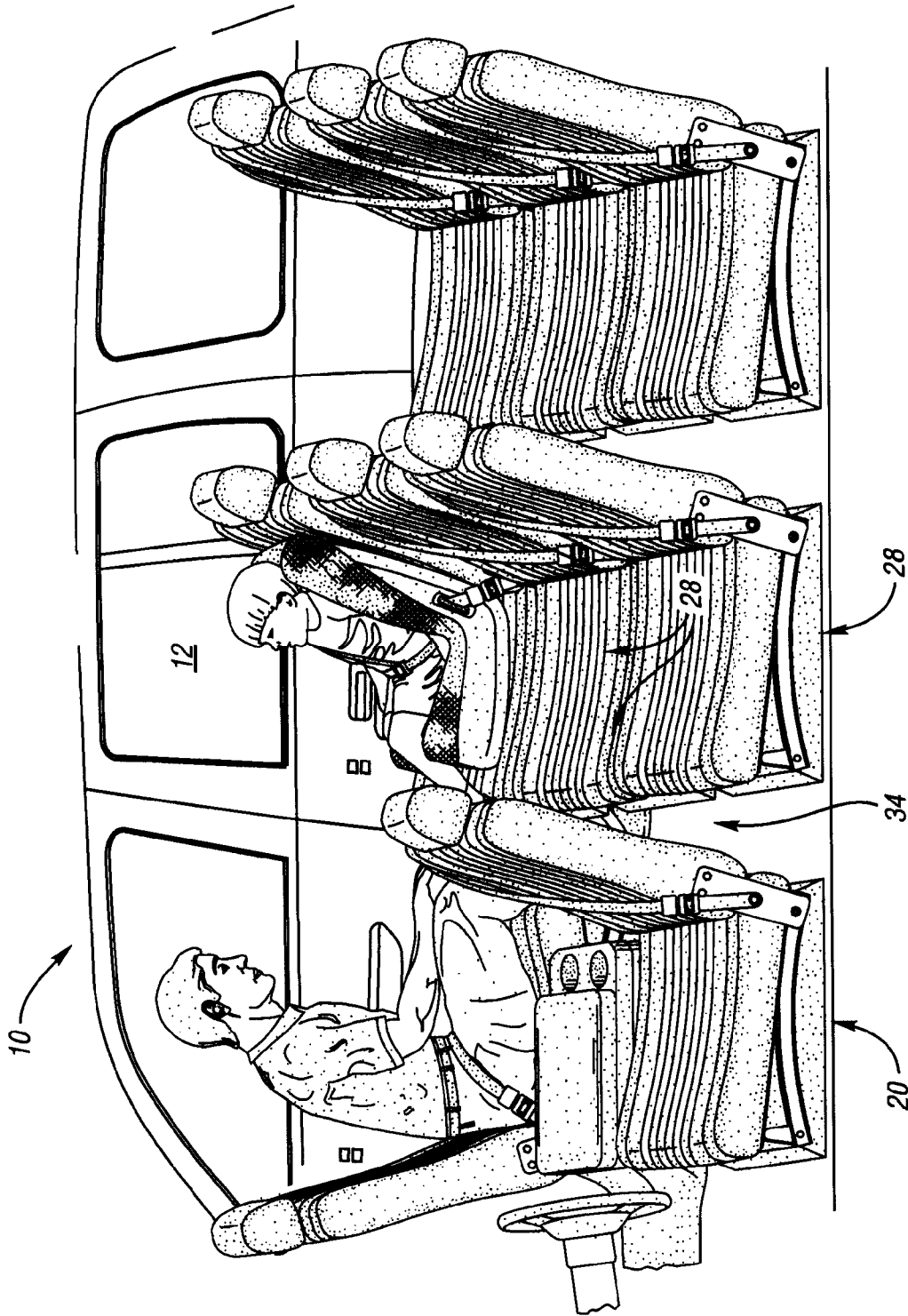

Fig. 2a

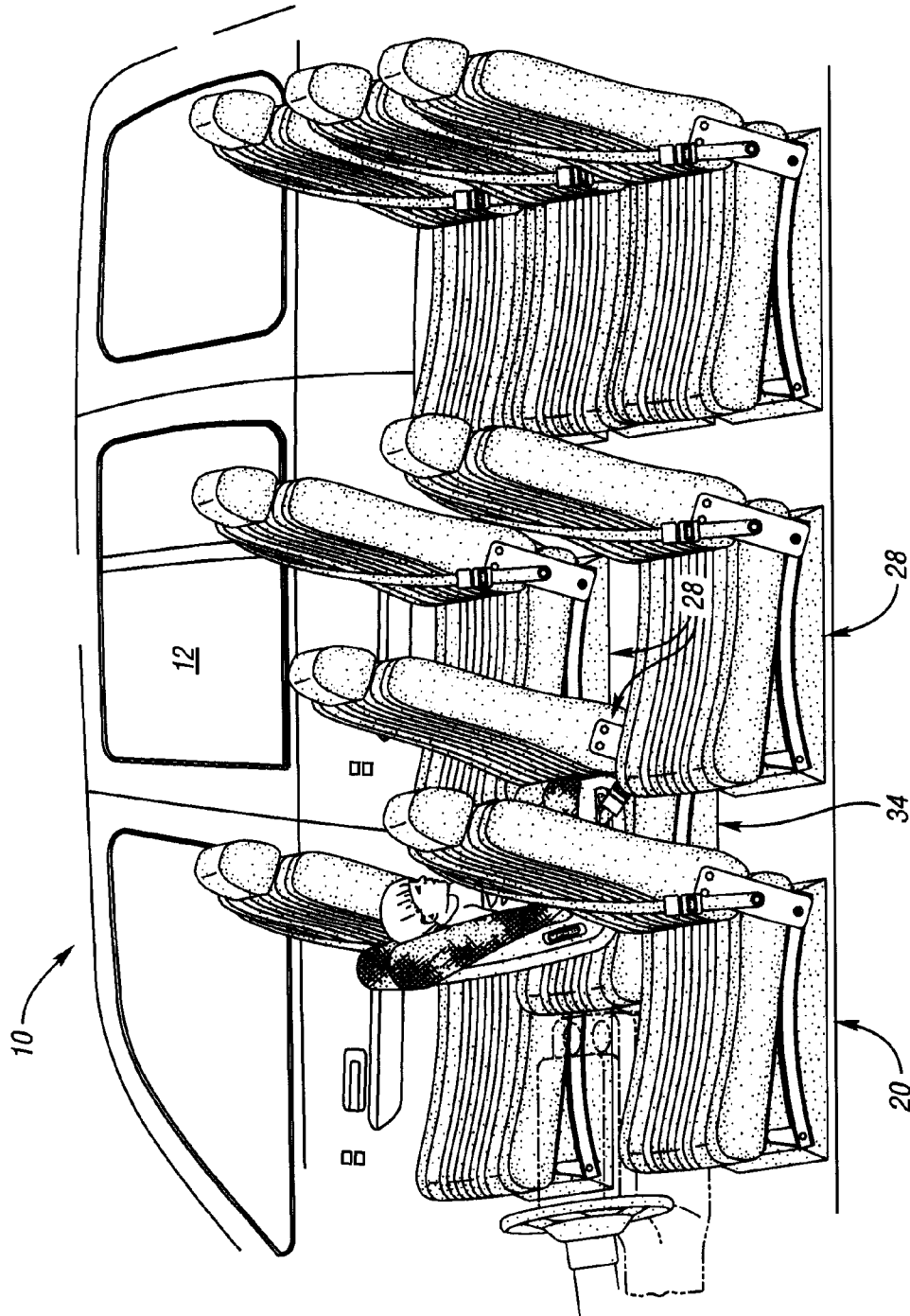

Fig. 2b

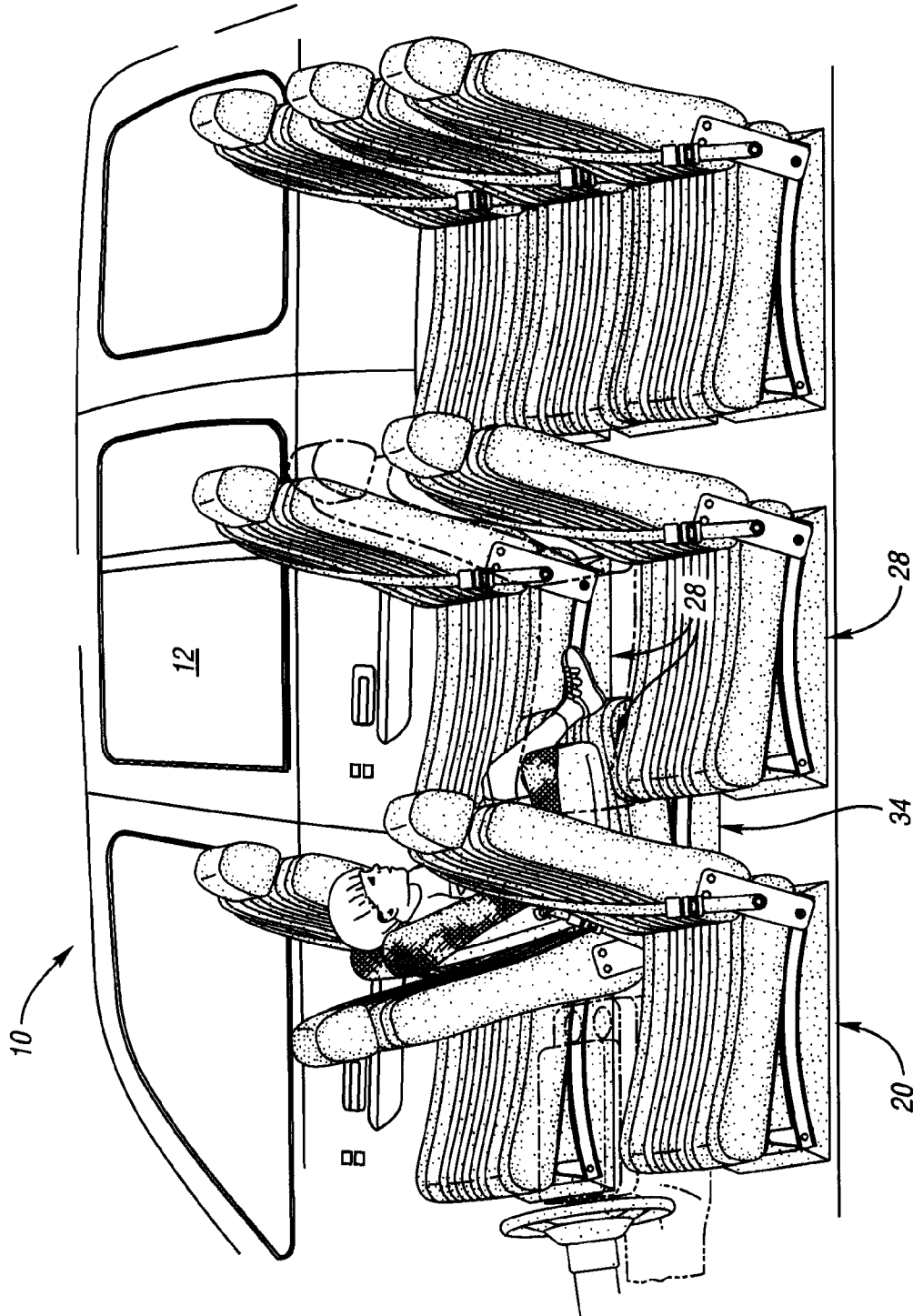

Fig. 2c

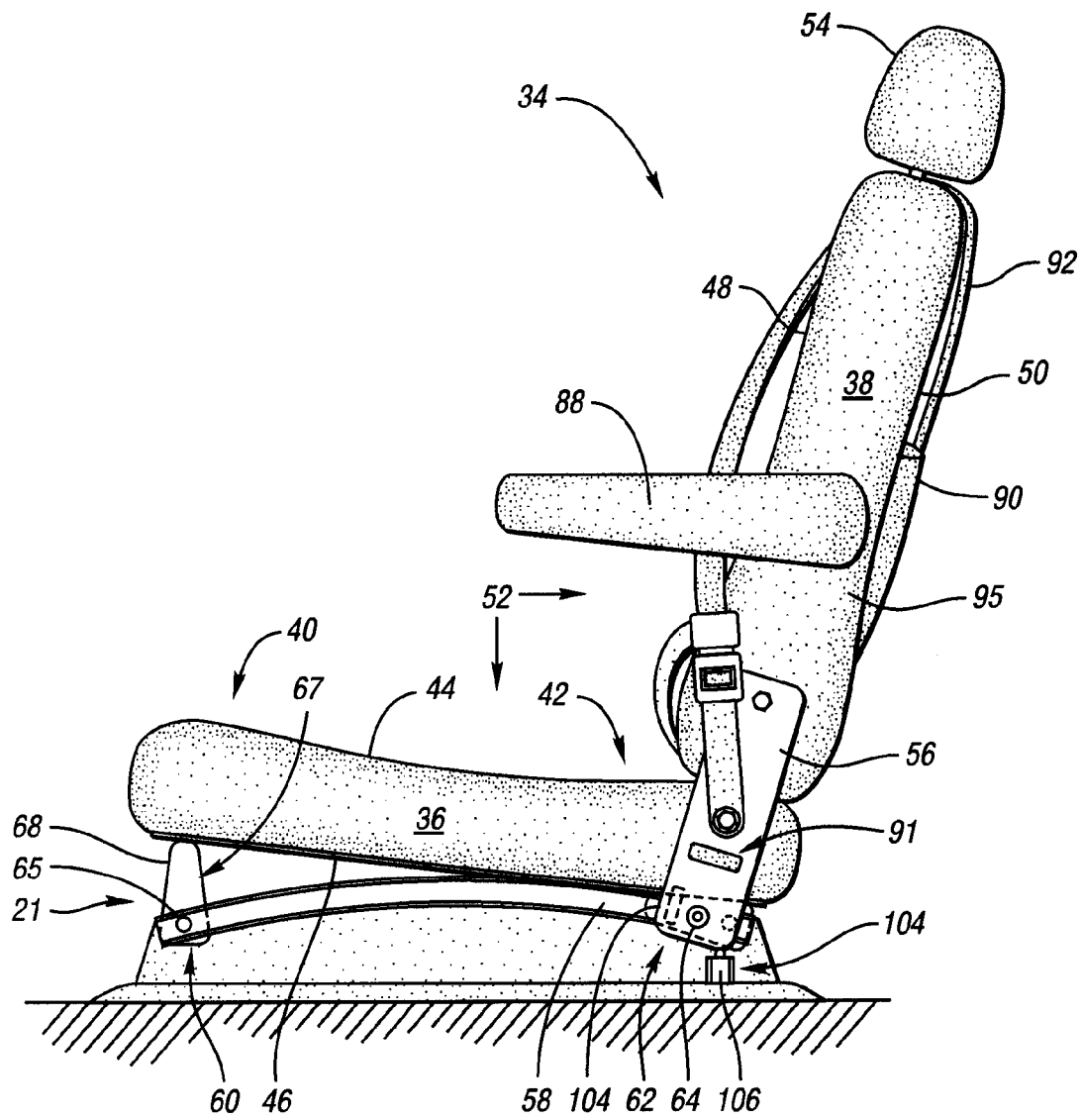

Fig. 3a

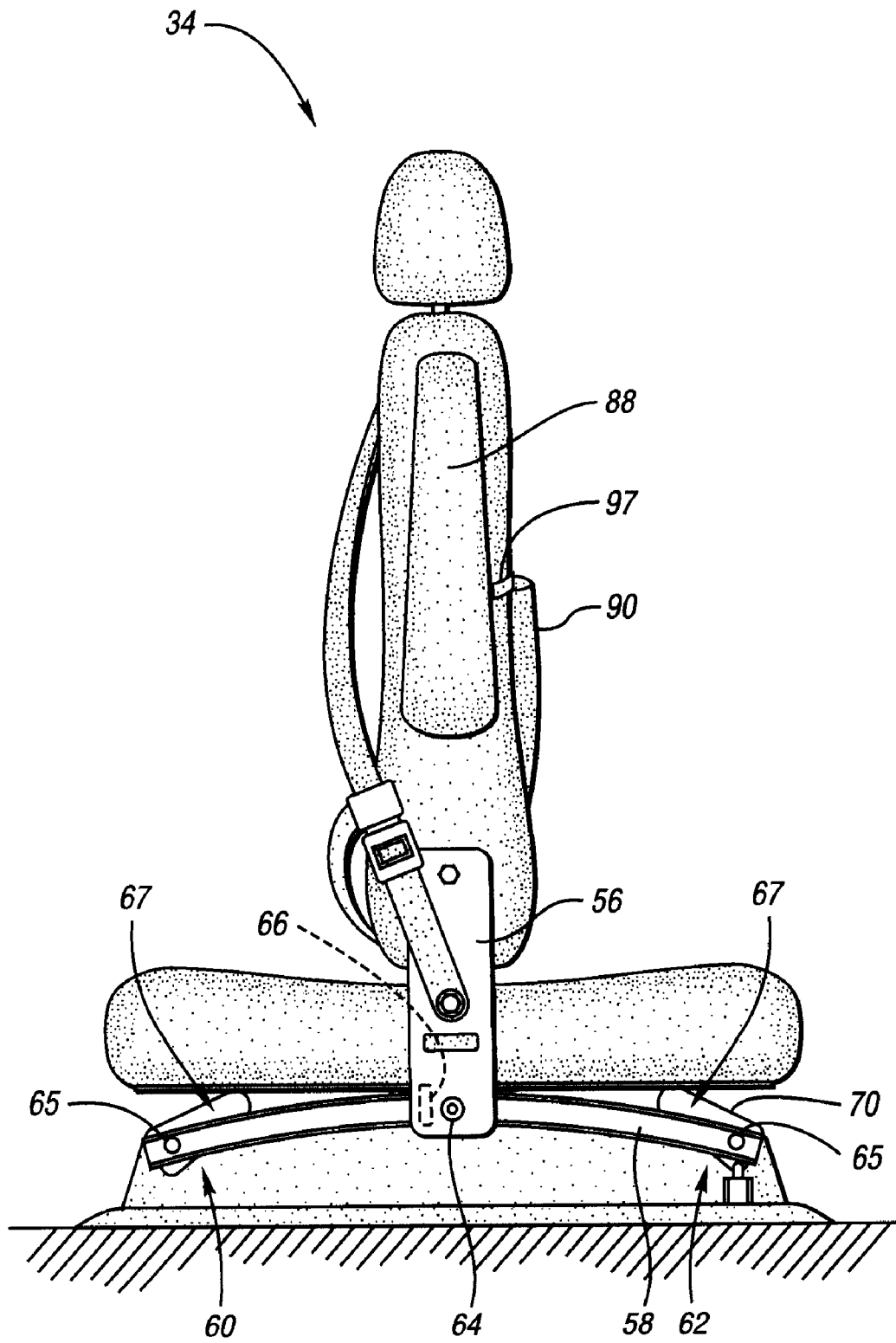

Fig. 3b

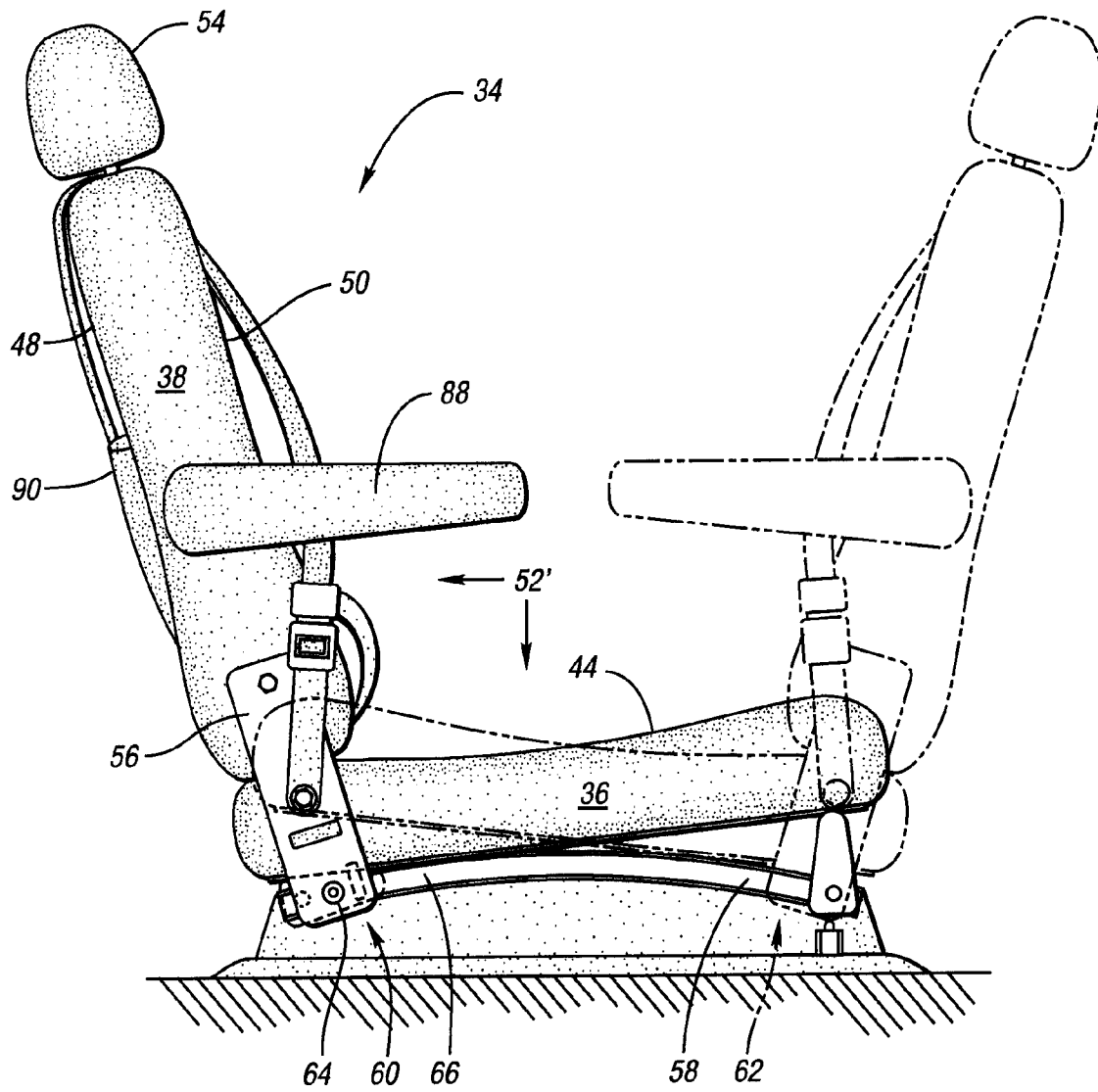

Fig. 3c

Fig. 3d

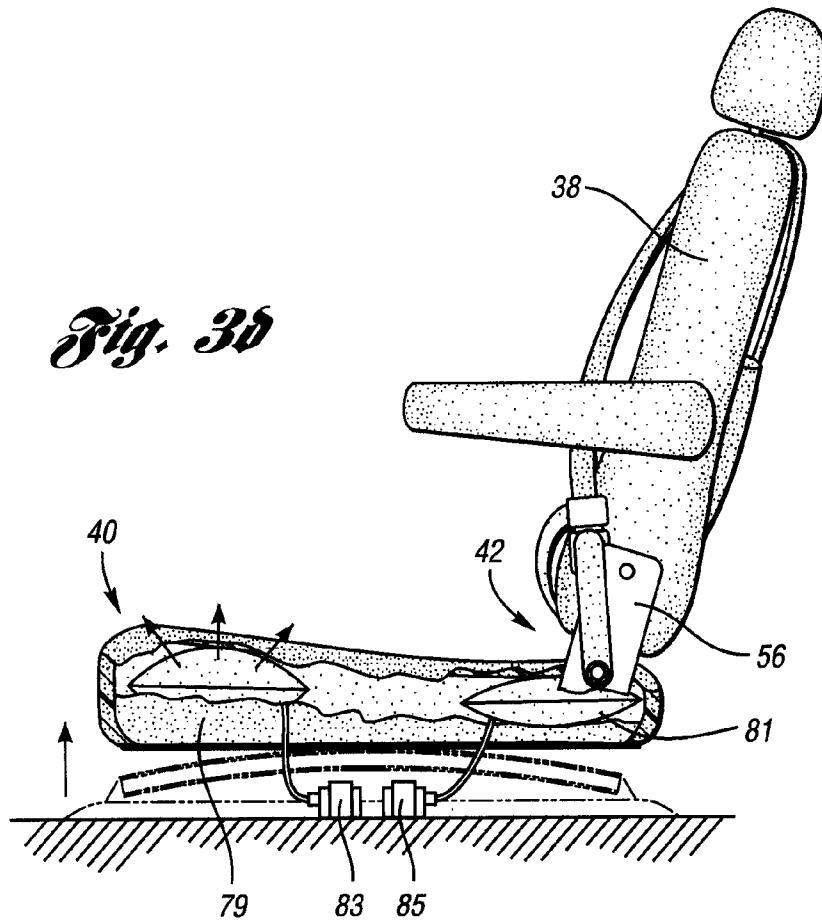
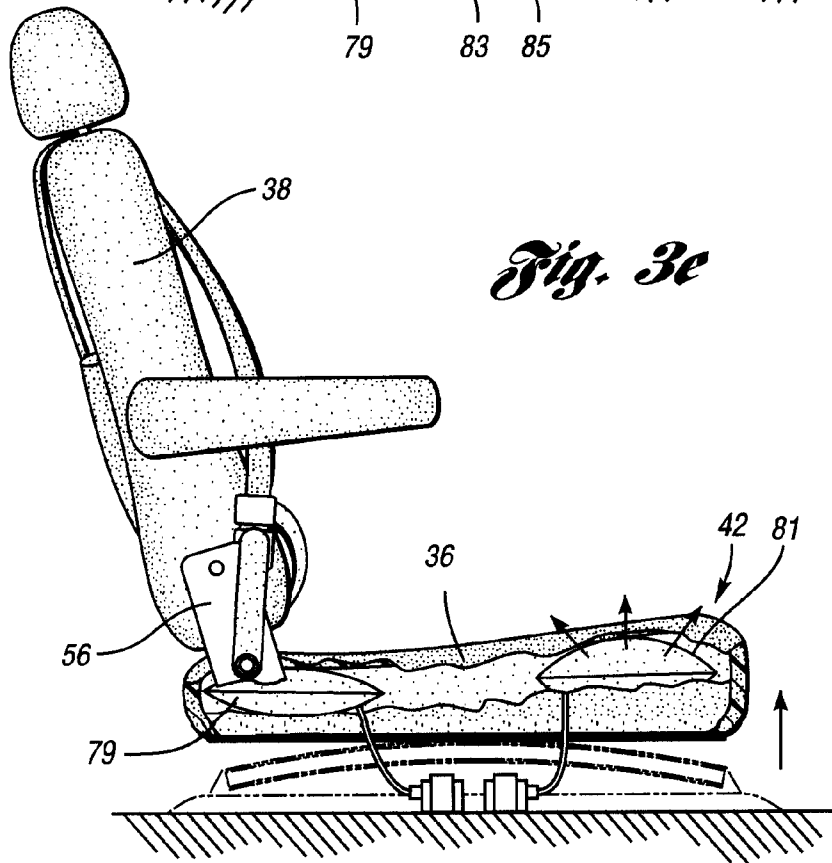
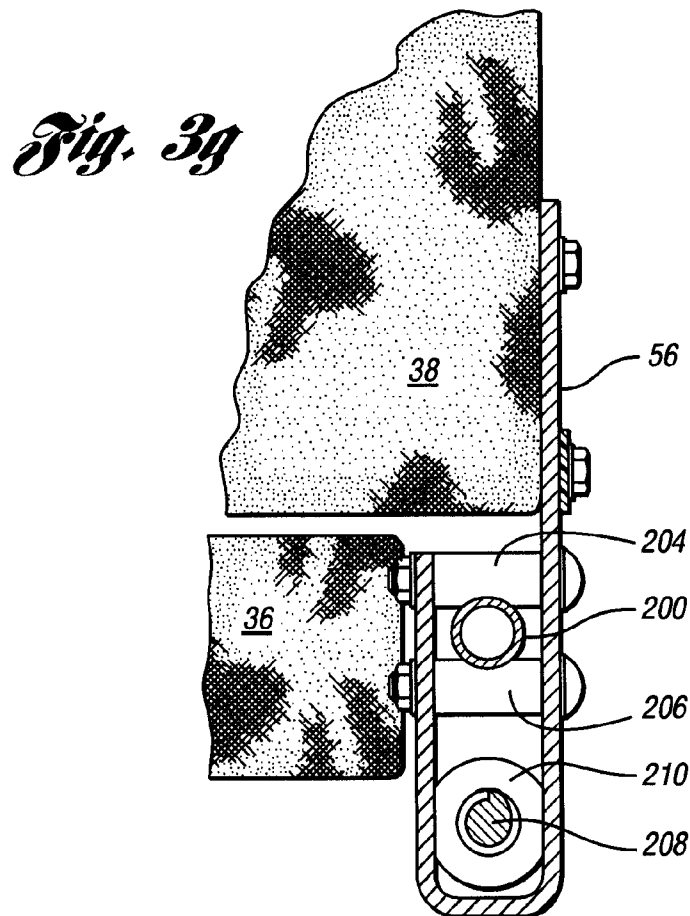
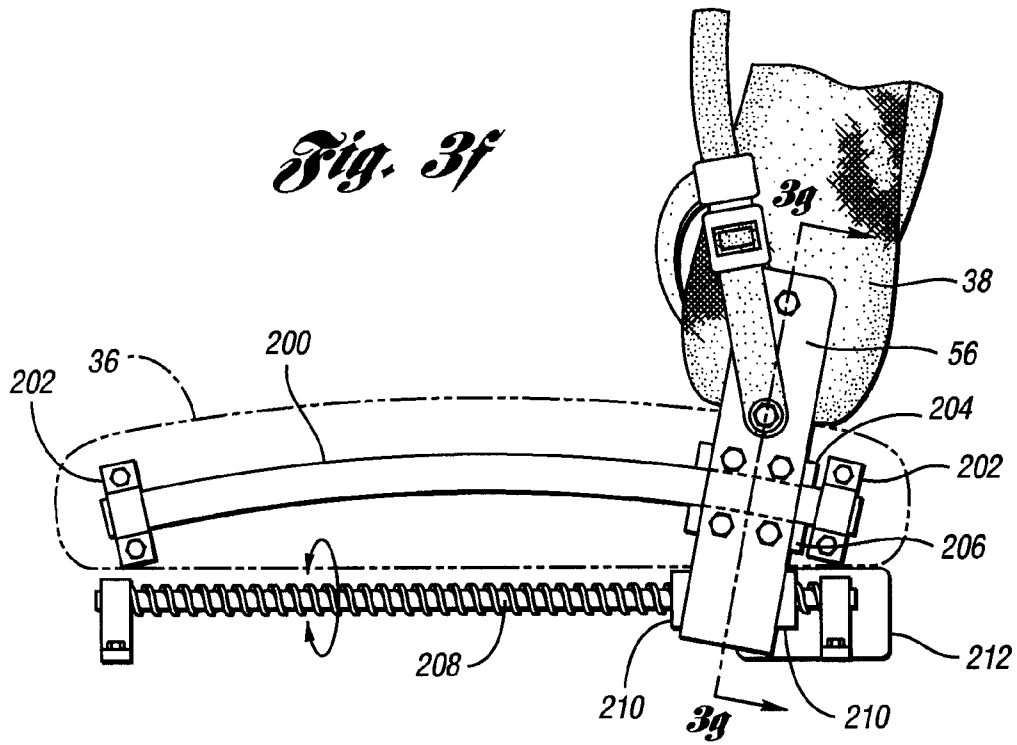

Fig. 3e





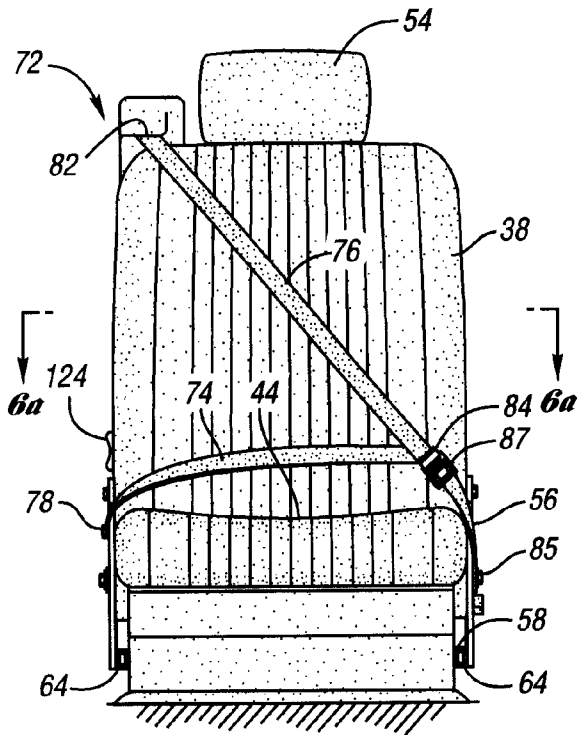

Fig. 4a

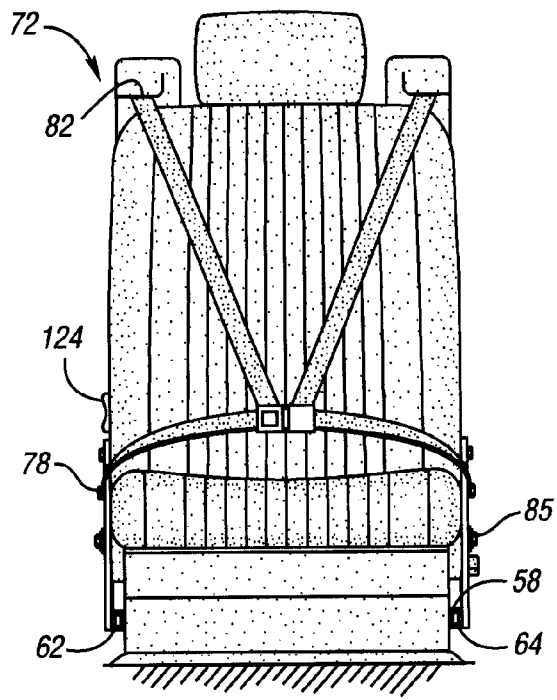

Fig. 4c

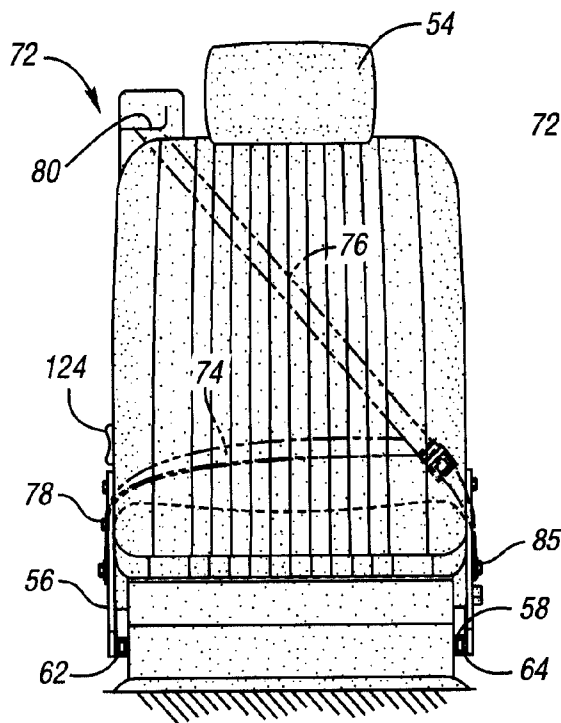

Fig. 4b

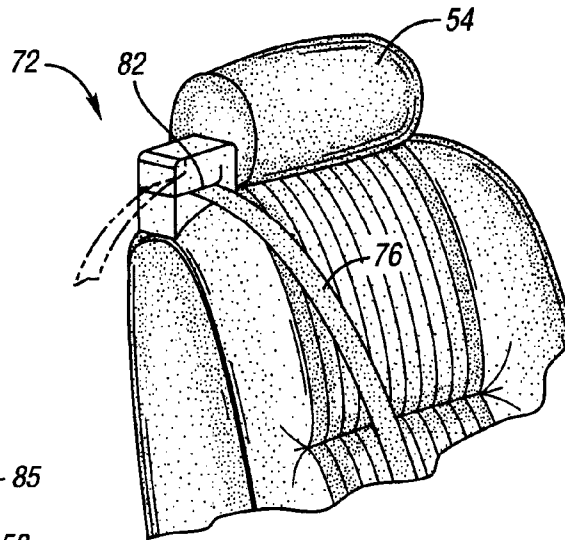

Fig. 4d

Fig. 5a

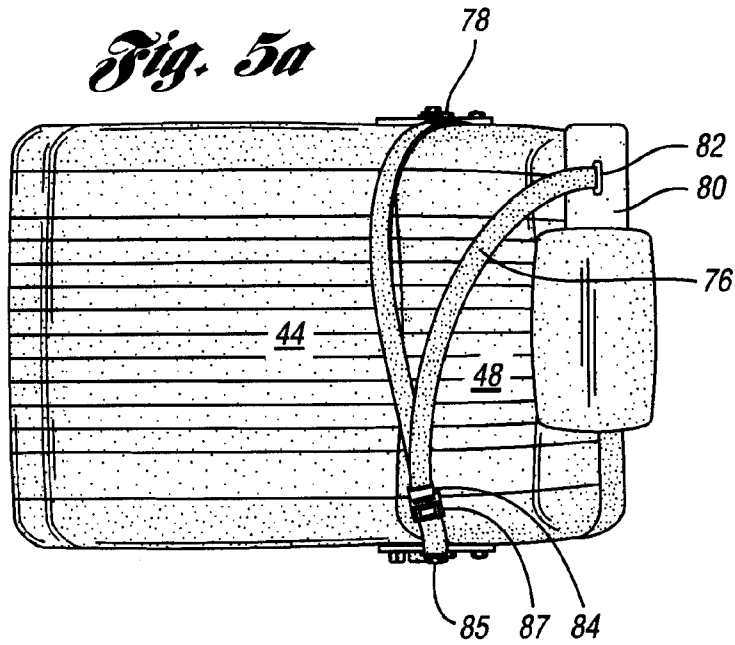

Fig. 5b

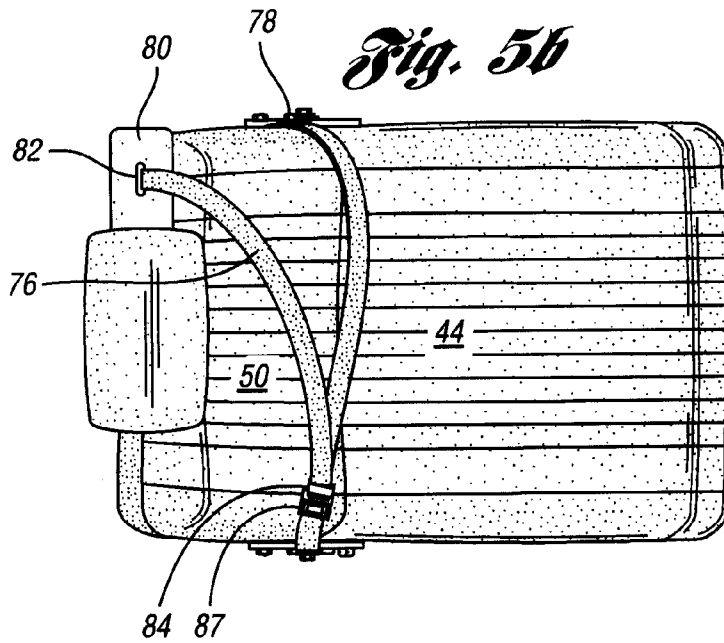
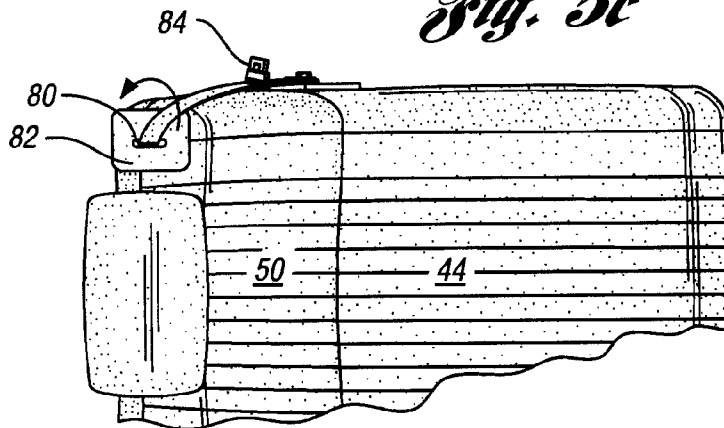

Fig. 5c



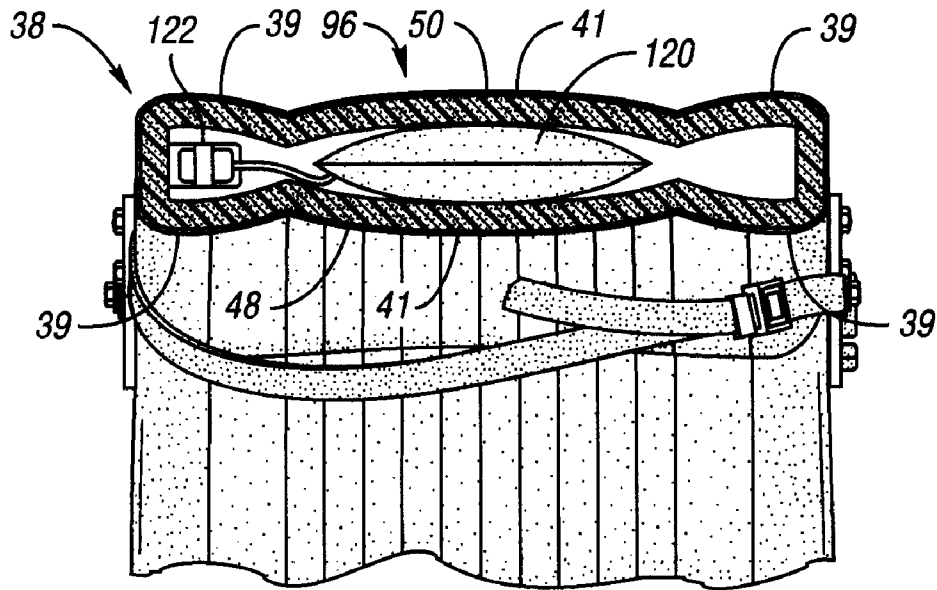

Fig. 6a

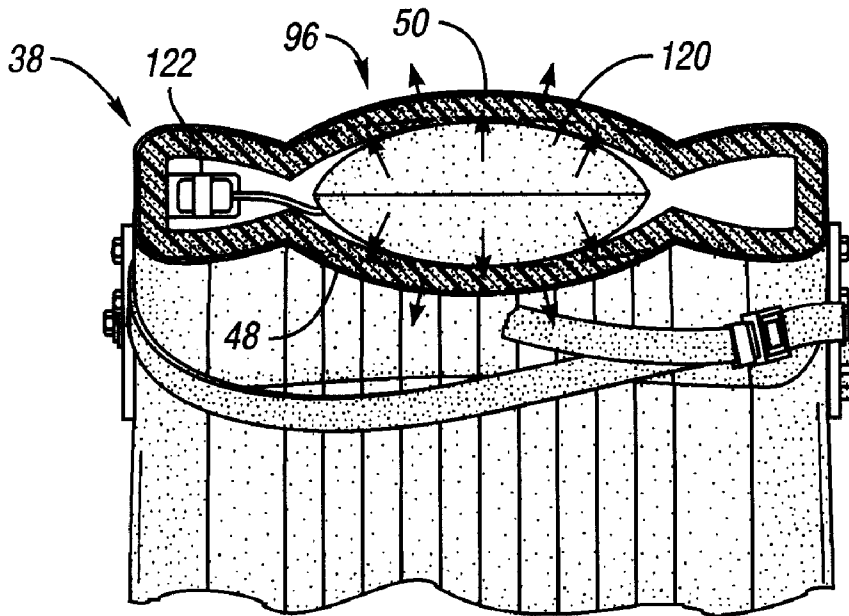

Fig. 6b

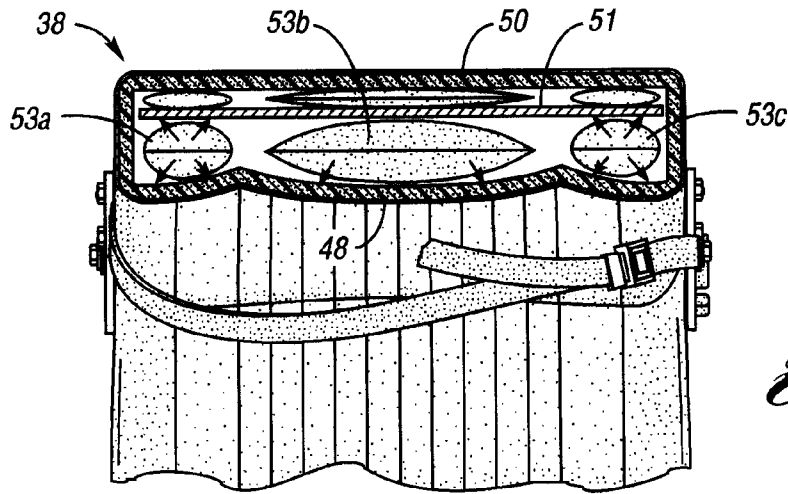

Fig. 6c

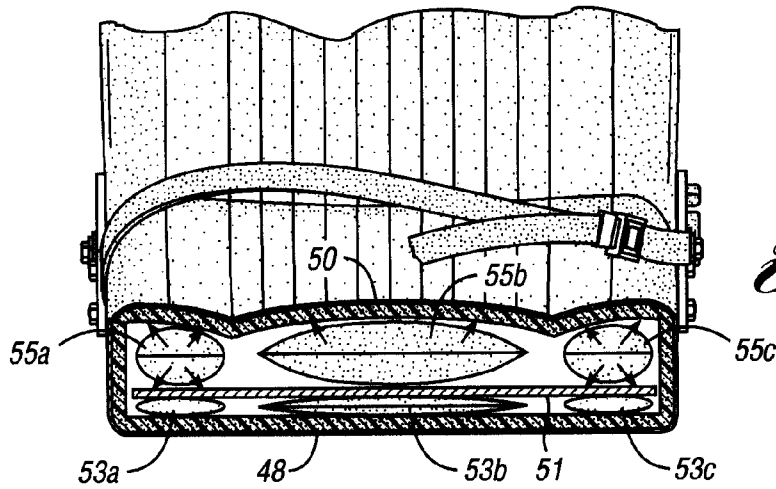

Fig. 6d

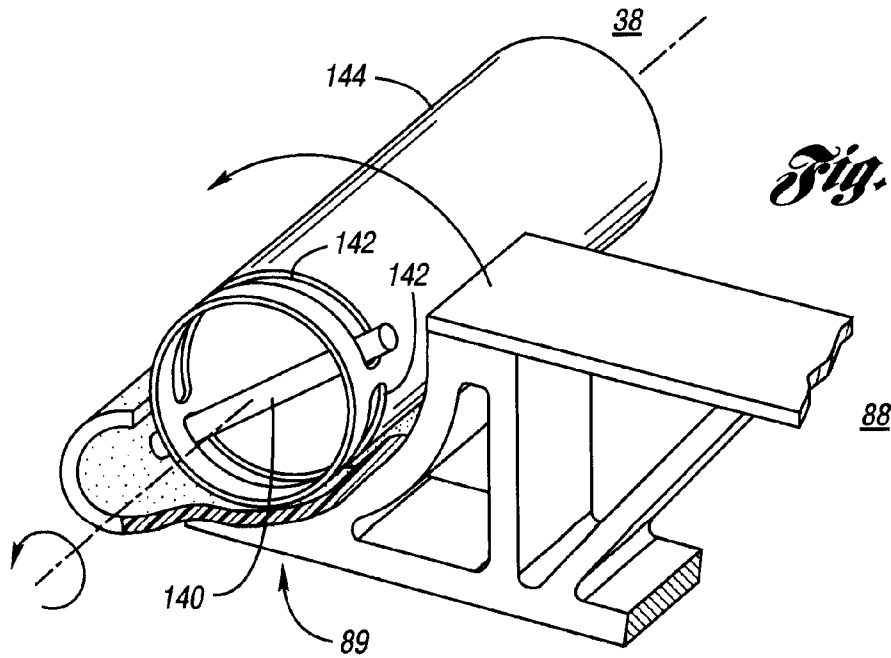

Fig. 7

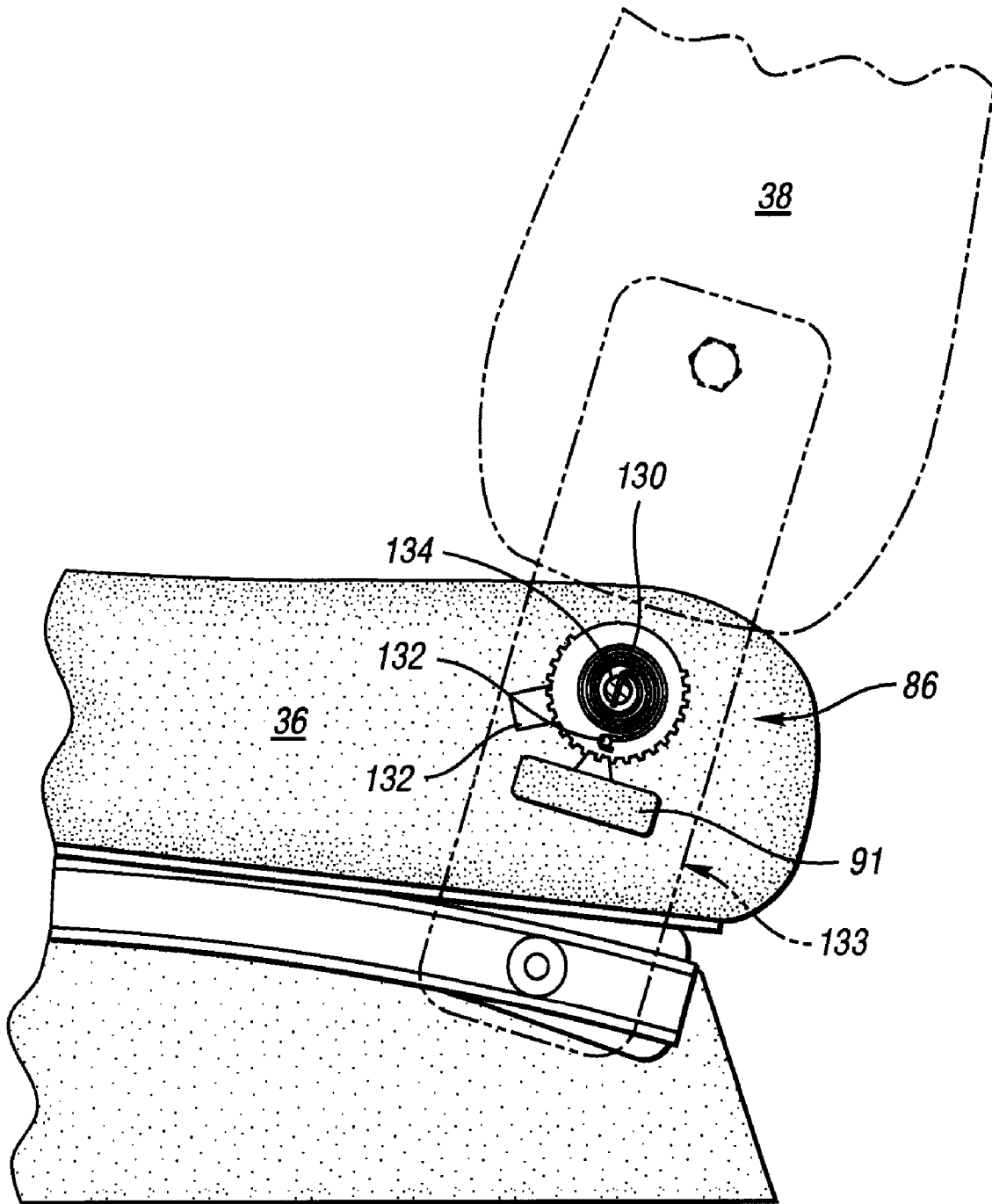

Fig. 8

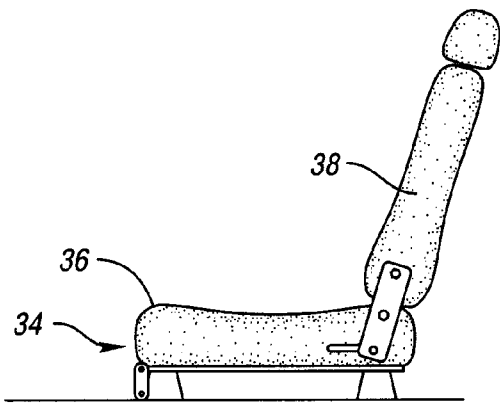

Fig. 9a

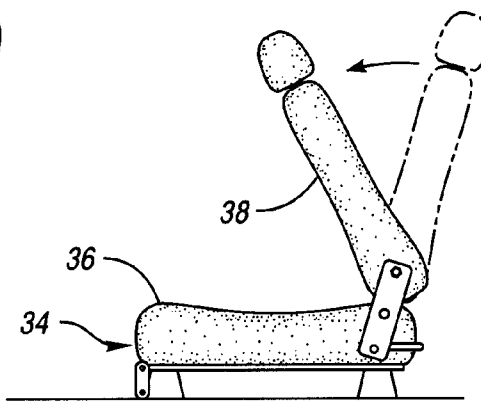

Fig. 9b

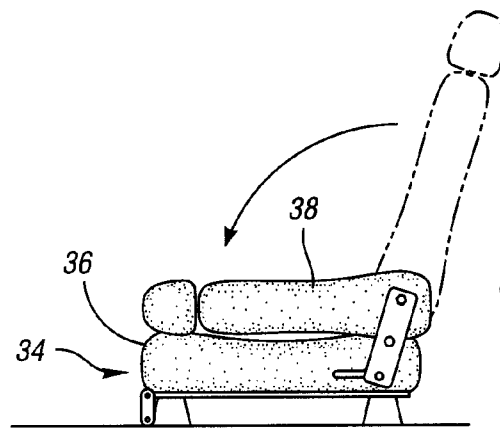

Fig. 9c

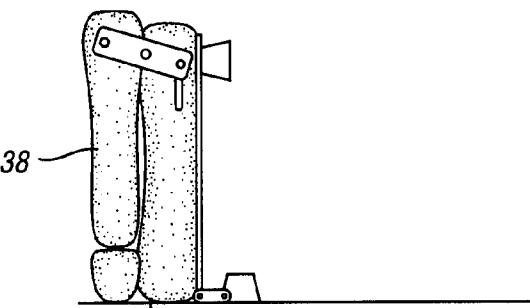

Fig. 9d

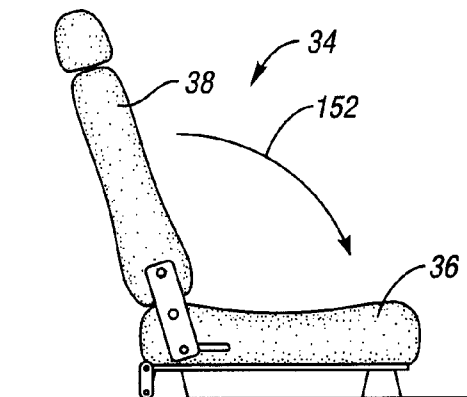

Fig. 10a

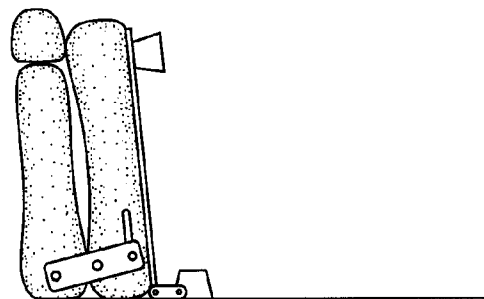

Fig. 10b

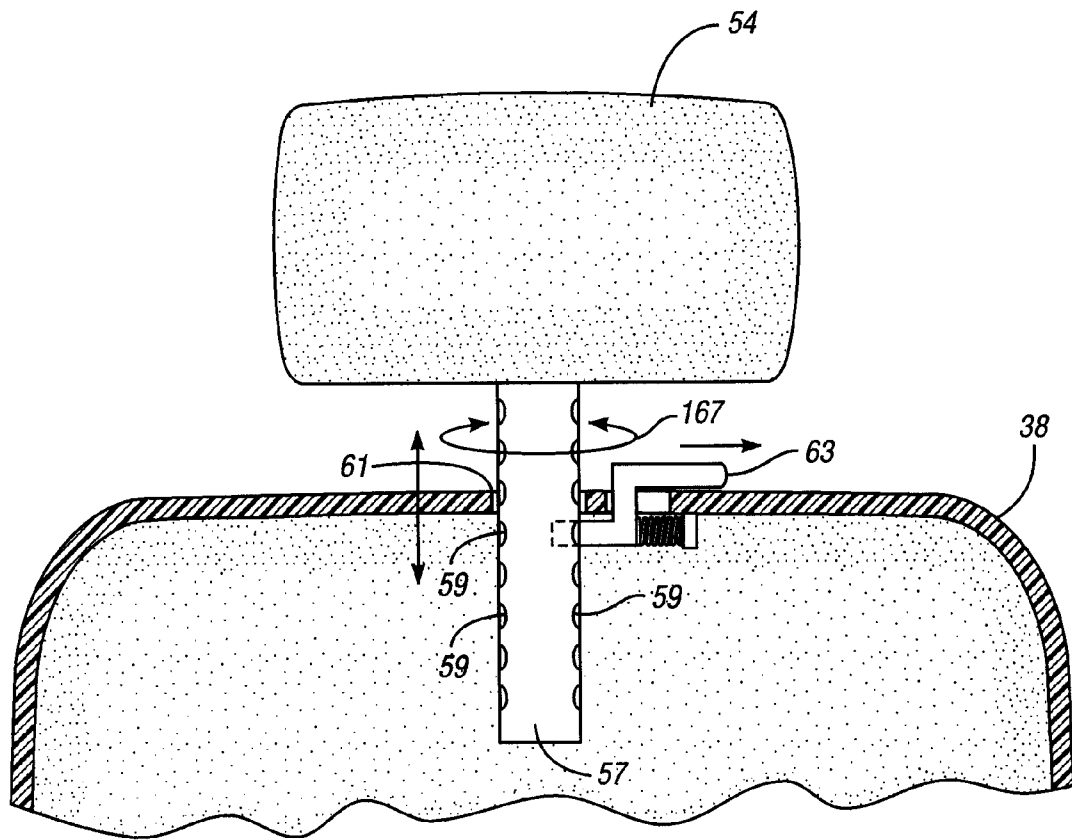

Fig. 11

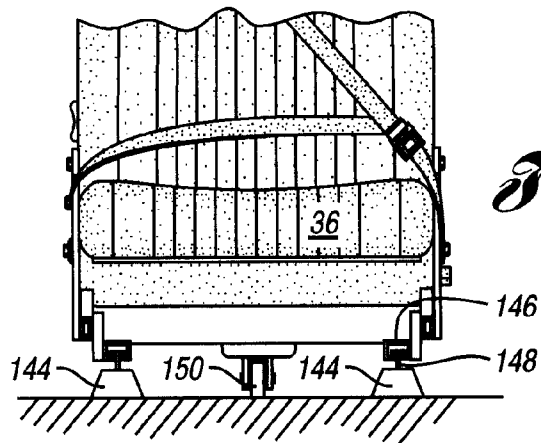
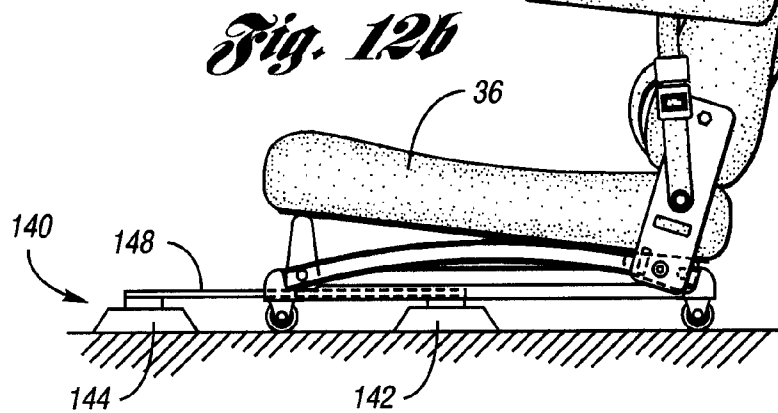
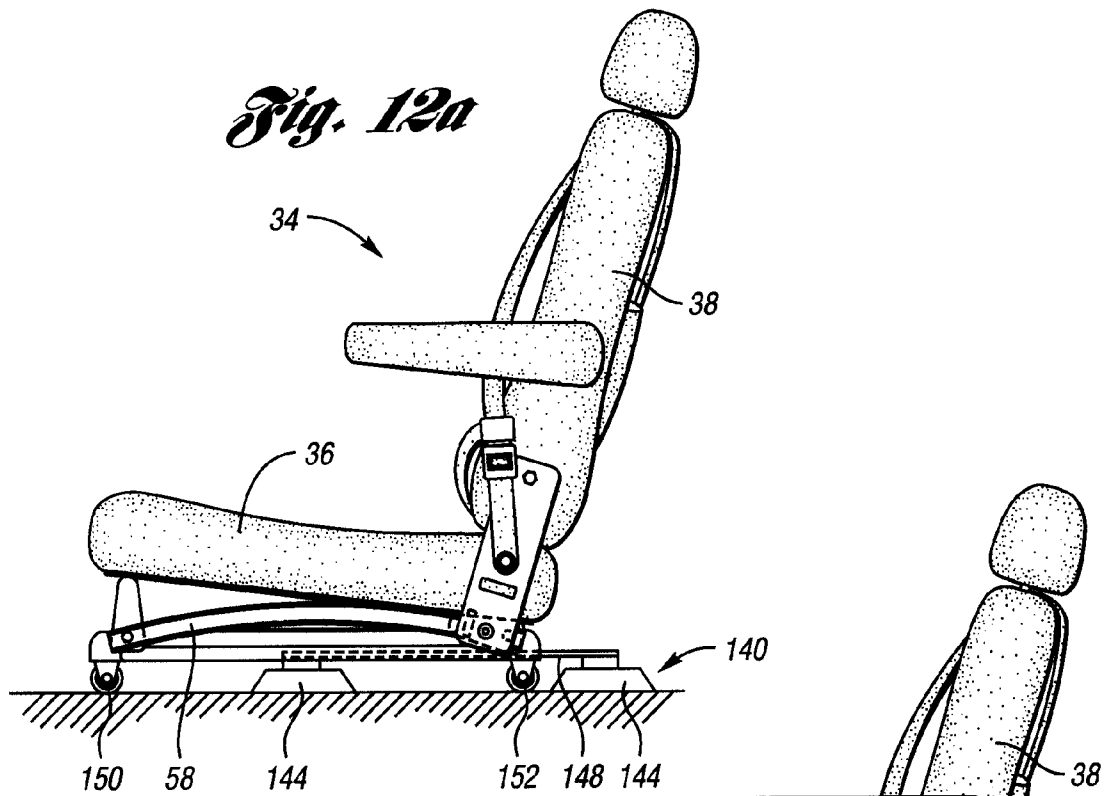

Fig. 13a

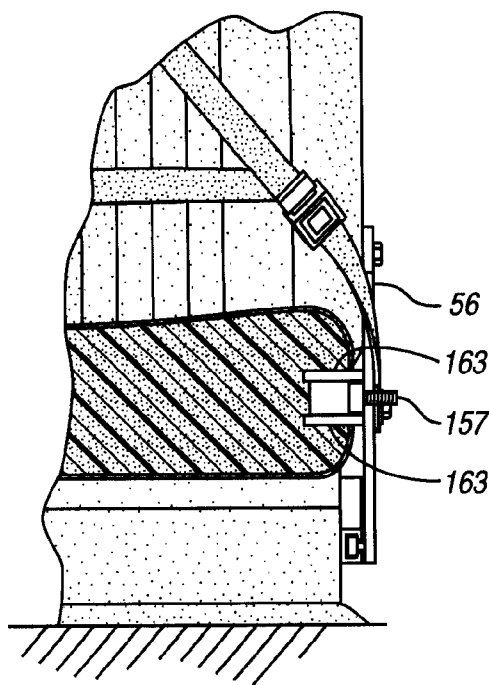
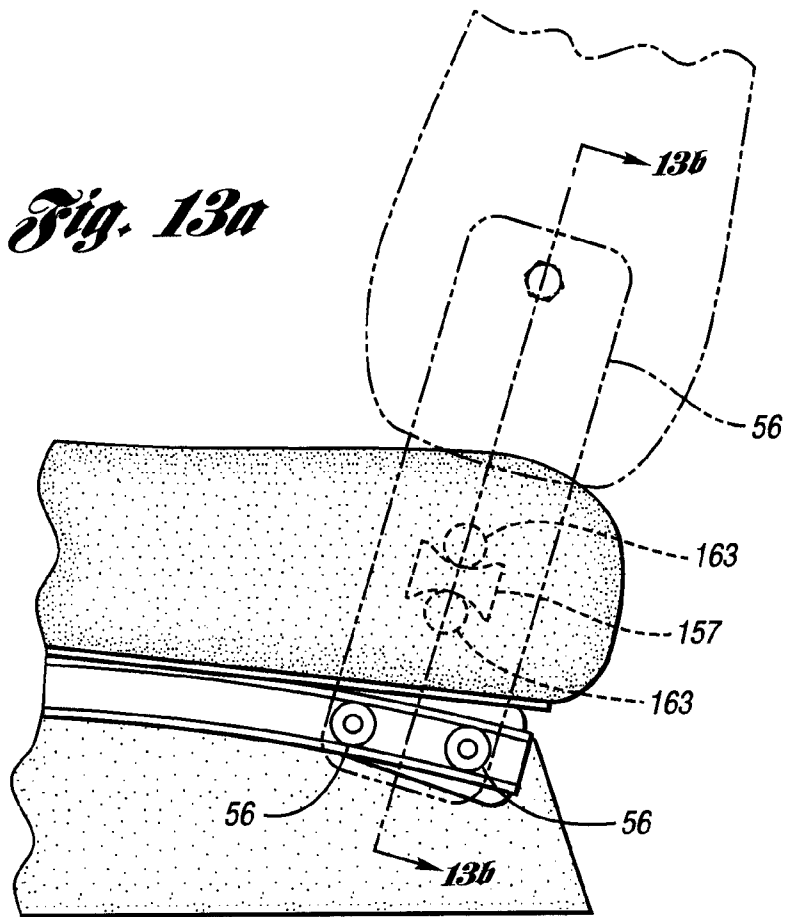

Fig. 13b

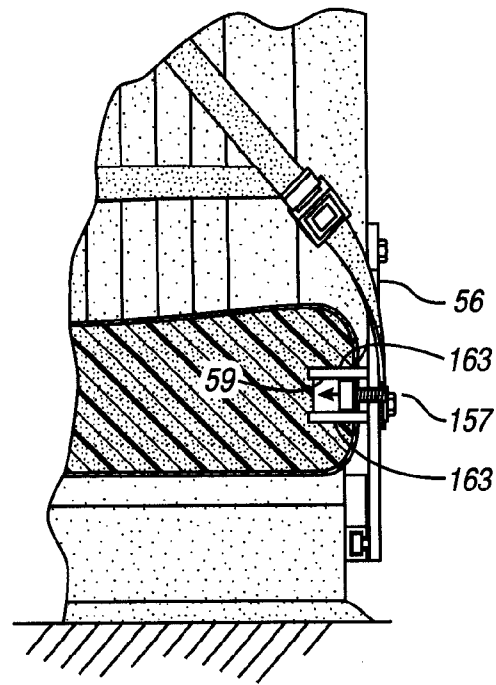

Fig. 13c

Fig. 13b

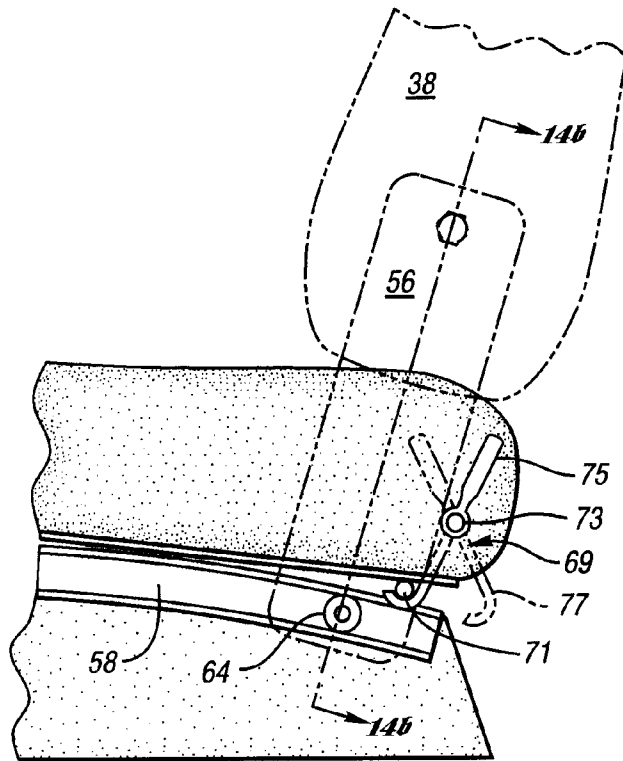
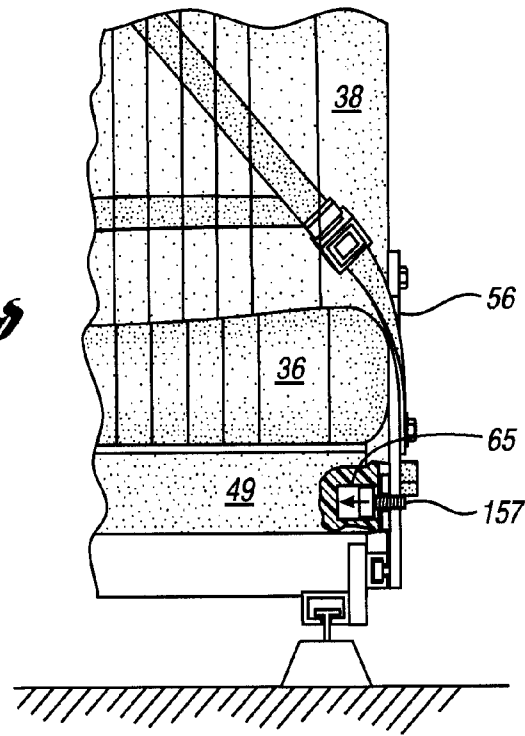

Fig. 14a

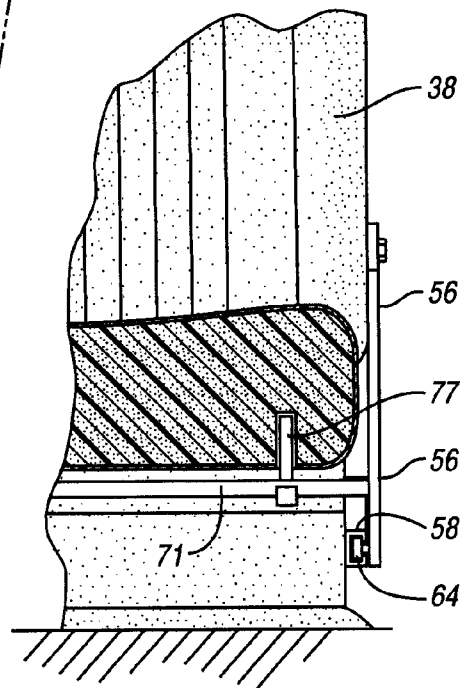

Fig. 14b

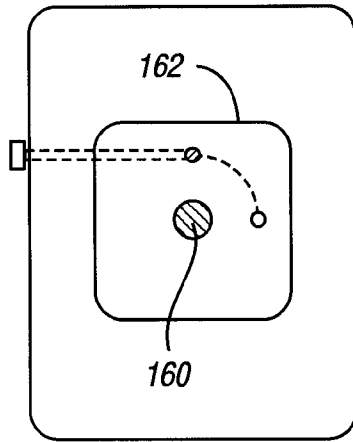

Fig. 15a

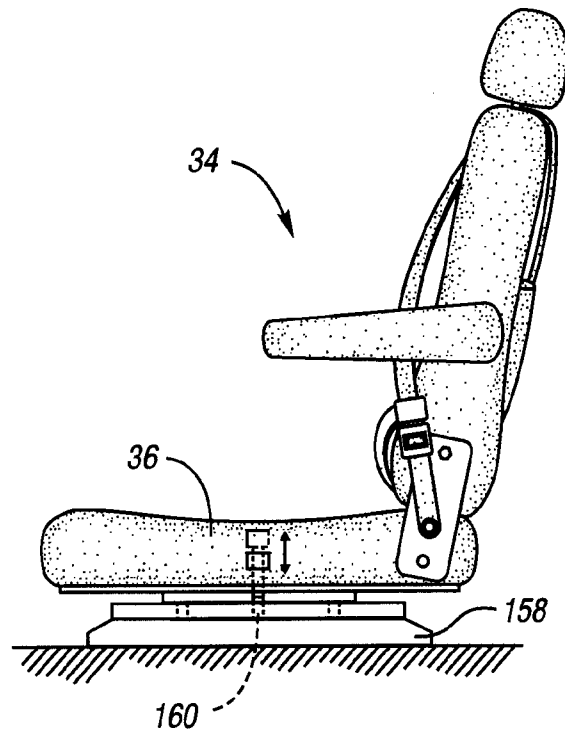

Fig. 15c

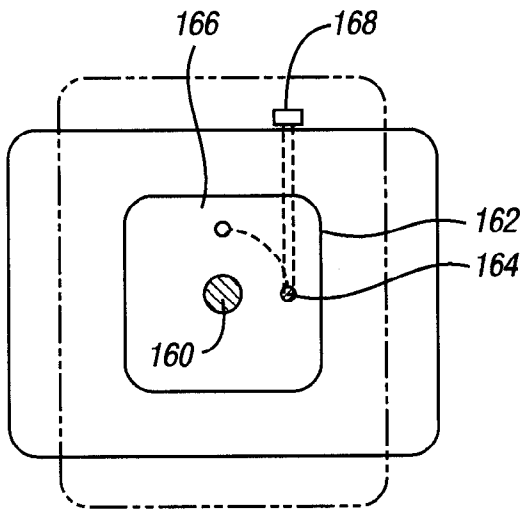

Fig. 15b

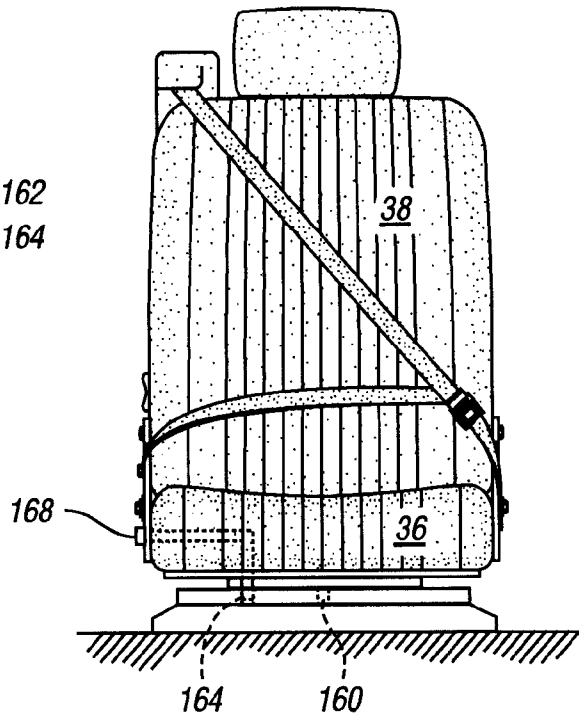

Fig. 15d

1

SEAT CONFIGURATION SYSTEM FOR AN AUTOMOTIVE INTERIOR

CROSS-REFERENCE TO RELATED APPLICATIONS

This application is a division of U.S. application Ser. No. 10/709,403 filed May 3, 2004, now U.S. Pat. No. 7,281,761.

BACKGROUND OF THE INVENTION

1. Field of the Invention

The invention relates to seating arrangements and configurations for automotive vehicles, and, in particular, to seating systems for flexible, comfortable and safe automotive travel.

2. Background Art

Comfort, convenience and versatility are at a premium for today's modern traveler. Accordingly, the automotive industry has taken significant steps to accommodate the evolving needs of its customers. Examples of such recent improvements in the automotive world include multi-zone climate control systems, passenger entertainment modules, and interior/exterior vision systems.

To meet the needs of its customers, the desire to provide seats adaptable for various travel situations has emerged. Families and other groups often compromise between the need for comfortable and convenient seating arrangements and storage. To accommodate the varying needs amongst potential customers, various seating systems have become known in the art.

One such seating apparatus allows users to detach and remove a vehicle seat from the vehicle's interior to increase the amount of storage space available. The vehicle seat can then be returned to the vehicle should additional seating capacity be needed. While the removable seat application provides increased versatility for hauling either a large amount of cargo, or rather, a large family, inserting and removing such seats can be a cumbersome task. Further, such seats are often limited in their movement and adjustability within the vehicle. Generally, two or more individuals are required to unlatch and remove the seat from the vehicle. Once removed, a storage location for the bulky seat is then needed when the seat can be kept clean and dry.

Other seating devices allow for the flexibility between additional storage and additional seating capacity without necessarily removing one or more seats. For example, many vehicles have foldable seats wherein the backrest can be folded forward towards the seat cushion when not in use to provide additional cargo room. Generally, the folded seat collapses to create a portion of a floor for a cargo area. Such seats are popular in SUVs and vans, but have also been introduced into the backseat of cars to access the trunk. While such seating devices are convenient for rapidly alternating between extra cargo room and extra seating, they provide little versatility for varying the seating configuration to adjust for a host of traveling situations.

Recent trends show that today's travelers have a greater need for flexibility in their automotive interiors. More individuals are taking their business on the road and spend a great deal of time in their automobile. Still others have young families they wish to take on long drives, perhaps during a vacation. To better accommodate the needs of these travelers, more flexible seating arrangements and configurations are in need. For example, nothing currently in production provides for a flexible, convenient, safe, and comfortable way to travel while still allowing passengers to conduct business face-to-face. Further, families are not afforded the option of allowing

2

their children to either face forward or rearward, without concern over seat belt restraint mechanisms or unsafe air bag deployment.

The previous known seating systems are problematic with regard to flexibility convenience, safety, and/or comfort. The present invention overcomes the above disadvantages by providing a unique and truly versatile seating arrangement and configuration system that maintains comfort and safety standards during vehicle operation.

SUMMARY OF THE INVENTION

Therefore, it is an aspect of the present invention to provide a truly unique and versatile automotive seating system.

It is another aspect of the present invention to provide an apparatus for flexible, convenient, and versatile seating during automotive travel, including safe and comfortable alternative seating arrangements and configurations.

Another aspect of the present invention is to provide automotive seating having a reversible seat wherein the backrest can be adjusted to face either forward or rearward.

Yet another aspect of the present invention is to provide reversible seats that allow the backrest to slide from the rear end of the seat cushion towards the front end of the seat cushion enabling the backrest to position in either the fore or the aft position.

Yet another aspect of the present invention is to provide automotive seating wherein both sides of the backrest are contoured to offer comparable comfort, support, and safety in either the rearward-facing or forward-facing directions.

Still another aspect of the present invention is to provide safe, convenient, and flexible automotive seating arrangements and configurations for all types of travel, including conferencing/work areas for the business traveler and entertainment/play areas for the traveling family.

Still another aspect of the present invention is to provide safe, convenient, and flexible reversible seats that can function similarly in either the forward-facing or rearward-facing direction, including seat cushion adjustment vertically in both the front and rear, horizontally, and reclining.

Still yet another aspect of the present invention is to provide safe, convenient, and flexible automotive reversible seats wherein the seat belt restraint system can adapt to properly restrain passengers facing either forward or rearward.

Still yet another aspect of the present invention is to provide safe, convenient, and flexible automotive seating wherein airbag deployment can be deactivated upon adjusting the reversible seats in the rearward-facing direction.

Yet another aspect of the present invention is to provide a rotatable headrest to provide comparable comfort in a reversible seat when the seat is either forward-facing or rearward-facing.

And still yet another aspect of the present invention is to provide safe, convenient, and flexible reversible seating wherein a map pocket or pouch is attached to the seat such that it can alternate its position in relation to the backrest depending on whether the backrest is in the fore or aft position.

Accordingly, numerous automotive seats of the present invention are disclosed in this application. One such automotive seat comprises a seat cushion having a front portion and a rear portion. A backrest is coupled to the seat cushion and is movable between a forward seating position (front facing) and a rearward seating (rear facing) position. In the forward seating position, the backrest adjoins the rear portion of the seat cushion. In the rearward seating position, the backrest adjoins the front portion of the seat cushion. The backrest contains a front face and a back face. When in the forward

3

seating position, a seating surface, generally defined by the front face of the backrest and the seat cushion, is provided. The seat cushion is tilted to provide an inclination from the seat back toward the edge of the seat for comfort and safety. However, when the backrest is in the rearward seating position, the seating surface is generally defined by the back face of the backrest and the seat cushion. Further when in the rearward seating position, the inclination of the seat cushion is reversed to provide comparable comfort and safety.

Other seats disclosed also comprise a restraint system integrated with the backrest for securing a seat occupant thereto. The restraint system is adaptable for securing the seat occupant when the backrest is in either the forward seating position or the rearward seating position. Moreover, the front face and the back face of the backrest are substantially similarly contoured, both of which having lateral supports.

Still other automotive seats described comprise an airbag deactivation device. The airbag deactivation device allows for a vehicle airbag to be deployed upon a vehicle collision when the backrest is in the forward seating position. However, the airbag deactivation device deactivates the airbag when the backrest is moved to the rearward seating position.

Also provided with other automotive seats disclosed is a recline mechanism for altering the angle between the backrest and the seat cushion. The recline mechanism is operable with the backrest in either the forward or rearward seating positions. A pair of armrests pivotally attached to the backrest, are also adapted between the forward seating position and the rearward seating position. Moreover, a two-way adjustable lumbar support is retained within the backrest between the front face and the back face. The lumbar support is selectively adjustable to support an occupant when the backrest is in either the forward or rearward seating positions.

Correspondingly, an automotive vehicle interior having a seating arrangement system is provided. The automotive vehicle comprises an interior having a front cabin, a rear cabin, and an intermediate cabin. A first row of seats generally located within the front cabin of the interior is provided. Behind the first row of seats is a second row of seats, generally parallel to the first row and located within the intermediate cabin of the interior. Finally, a third row of seats, generally parallel to and positioned behind the second row, is located within the rear cabin of the interior. The vehicle utilizes at least one of the numerous seats disclosed and may include a seat cushion and a backrest movable between a forward seating position and a rearward seating position. The backrest adjoins a rear portion of the seat cushion when in the forward seating position, while the backrest adjoins a front portion of the seat cushion when in the rearward seating position. The backrest further comprises a front face and a back face, both substantially similarly contoured. Further, the seat includes a two-way lap and shoulder restraint system integrated with the backrest for use in connection with either the front face or the back face of the backrest.

Further the at least one of the numerous seats disclosed may be located in the second row such that the at least one seat can be adjusted so that the backrest is in the rearward seating position, allowing an occupant to face the third row of seats. Moreover, the at least one seat can be located in the third row such that the at least one seat can be adjusted so that the backrest is in the rearward seating position, allowing an occupant to face the rear of the vehicle. Finally, the at least one seat is located in the first row such that the at least one seat can be adjusted so that the backrest is in the rearward seating position, allowing an occupant to face the second row of seats.

The above aspects and other objects, features, and advantages of the present invention are readily apparent from the

4

following detailed description of the best mode for carrying out the invention when taken in connection with the accompanying drawings.

BRIEF DESCRIPTION OF THE DRAWINGS

FIG. 1a is an environmental view of a vehicle interior having a reversible seat, according to a certain embodiment of the present invention;

FIG. 1b is an environmental view of a vehicle interior having a reversible seat, according to an alternate embodiment of the present invention;

FIG. 1c is an environmental view of a vehicle interior having a reversible seat, according to yet another embodiment of the present invention;

FIG. 2a is a perspective view of a certain embodiment of the present invention;

FIG. 2b is another perspective view of a certain embodiment of the present invention;

FIG. 2c is another perspective view of a certain embodiment of the present invention;

FIG. 3a is a side view of a reversible seat in the forward seating position;

FIG. 3b is a side view of a reversible seat in FIG. 3a being translated from the forward seating position to the rearward seating position;

FIG. 3c is a side view of a reversible seat in FIG. 3a in the rearward seating position including the reversible seat in the forward seating position shown in phantom;

FIG. 3d is a side view of another reversible seat in the forward seating position;

FIG. 3e is a side view of the reversible seat in FIG. 3d in the rearward seating position;

FIG. 3f is a side view of another reversible seat in the forward seating position;

FIG. 3g is a cross-sectional view along the line, 3g, of FIG. 3f.

FIG. 4a is a front view of a reversible seat in the forward seating position;

FIG. 4b is a front view of the reversible seat in FIG. 4a in the rearward seating position;

FIG. 4c is an alternate reversible seat in the forward seating position;

FIG. 4d is a plan view illustrating the shoulder strap of one of the seats of the present invention;

FIG. 5a is a top view of a reversible seat in the forward seating position;

FIG. 5b is a top view of the reversible seat in FIG. 5a in the rearward seating position;

FIG. 5c is a top view of the reversible seat in FIG. 5a illustrating pivotal movement of the seat belt bezel;

FIG. 6a is a top sectional view of a reversible seat taken along the line 6a-6a shown in FIG. 4a, and illustrating a lumbar support feature;

FIG. 6b is a top sectional view of the reversible seat in FIG. 4a illustrating the lumbar support of FIG. 6a activated;

FIG. 6c is a top sectional view of a reversible seat taken along the line 6a-6a shown in FIG. 4a illustrated in the forward seating position.

FIG. 6d is a view of the cross section of the reversible seat in FIG. 6c shown in the rearward seating position;

FIG. 7 is a perspective view of the stop mechanism internal to an armrest according to a certain embodiment of the present invention;

FIG. 8 is a side view detailing the reversible recline mechanism according to a certain embodiment of the present invention;

5

FIG. 9a is a side view of one of the seats of the present invention shown in the forward seating position;

FIG. 9b is a side view of one of the seats of the present invention illustrating a first fold mechanism;

FIG. 9c is a side view of a seat of the present invention further illustrating the first fold mechanism;

FIG. 9d is a seat of the present invention illustrating a first tumble mechanism;

FIG. 10a is a seat of the present invention illustrated in the rearward seating position;

FIG. 10b is a side view of a seat of the present invention utilizing a second fold and tumble mechanism;

FIG. 11 is a frontal view of a headrest of one of the seats of the present invention;

FIG. 12a is a side view of one of the seats of the present invention illustrated in its forward most position;

FIG. 12b is a side view of the seat of the present invention shown in FIG. 12a in its rear most seating position;

FIG. 12c is a frontal view of the seat of the present invention shown in FIG. 12a;

FIG. 13a is a side view of one of the seats of the present invention illustrating a locking mechanism for the seat back;

FIG. 13b is a frontal view with a cross section through the seat cushion illustrating the locking mechanism of one of the seats of the present invention in the unlocked position;

FIG. 13c is a frontal view with a cross section through the seat cushion illustrating the locking mechanism of one of the seats of the present invention in the locked position;

FIG. 13d is an alternate locking arrangement for one of the seats of the present invention illustrated in the unlocked position;

FIG. 14a is a side view of an alternate embodiment of one of the seats of the present invention illustrating a seat back locking mechanism;

FIG. 14b is a frontal view with a cross section through the seat cushion illustrating the locking mechanism illustrated in FIG. 14a;

FIG. 15a is a view of a seat plate of one of the seats of the present invention in a forward or rearward seating position;

FIG. 15b is a seat plate of one of the seats of the present invention illustrated in the sideward seating position;

FIG. 15c is a side view of one of the seats of the present invention illustrated in the forward seating position; and

FIG. 15d is a front view of one of the seats of the present invention illustrated in the forward seating position.

DETAILED DESCRIPTION OF THE PREFERRED EMBODIMENTS

Detailed embodiments of the present invention are disclosed herein. However, it is to be understood that the disclosed embodiments are merely exemplary of an invention that may be embodied in various and alternative forms. Therefore, specific functional details disclosed herein are not to be interpreted as limiting, but merely as a representative basis for the claims and/or as a representative basis for teaching one skilled in the art to variously employ the present invention.

One aspect of the present invention is directed to an apparatus and system for providing a more flexible interior package for automotive vehicles described in greater detail below, the system, according to the present invention, allows vehicle passengers to readily adapt their seating arrangement to be more conducive to practical travel situations, without compromising passenger comfort and safety. The ability of the

6

system of the present invention to allow unique and versatile seating options decreases the burden on passengers when traveling via automobile.

Referring generally to FIGS. 1a-1d, vehicle 10 having a flexible interior package in accordance with a certain embodiment of the present invention is illustrated. Vehicle 10 is preferably a sport utility vehicle (SUV), van, or any such vehicle having at least three rows of seats, but may also be included in a standard sedan-type vehicle. Vehicle 10 includes interior 12 comprised of front cabin 14, rear cabin 16, and intermediate cabin 18. Front cabin 14 generally encompasses the area of interior 12 nearest the instrument panel 13, while rear cabin 16 generally encompasses the area of interior 12 nearest the rear of vehicle 10. Correspondingly, intermediate cabin 18 generally encompasses the area interposed between front cabin 14 and rear cabin 16.

Interior 12 further comprises first row seats 20 located within front cabin 14. Preferably, at least two seats comprise first row 20. Typically, as shown in FIGS. 1a-1c, first row seats 20 face forward toward windshield 22 and are generally aligned laterally across vehicle 10. In a certain embodiment, each seat in first row 20 is capable of translating linearly along the vehicle floor between a fore position, towards the front of vehicle 10, and an aft position, towards the rear of vehicle 10. It is therefore contemplated that any apparatus and method for providing horizontal travel of a vehicle seat between a fore position and an aft position can be utilized in accordance with the present invention, such as is known in the seat track art. For example, International Publication No. WO 02/14103 A1 discloses such a seat track arrangement, and is hereby incorporated by reference. An improved and unique seat track arrangement is also disclosed herein and described subsequently with regard to FIGS. 12a-12c.

Front cabin 14 is further defined by a forward boundary and a rearward boundary. The forward boundary, for example, can be dashboard 13 or some other object generally defining a boundary between interior 12 and an engine compartment of vehicle 10. The rearward boundary, on the other hand, is generally defined by the rearmost limit of a seat in first row 20 when translated in the aft position.

Second row of seats 28 is generally located within intermediate cabin 18. Preferably, at least two seats comprise second row 28. More preferably, three seats comprise second row 28. Second row 28 is generally parallel to and positioned behind first row 20, as depicted in FIGS. 1a-1c. In a certain embodiment, each seat in second row 28 is capable of translating linearly along the vehicle floor between a fore position, towards the front of vehicle 10, and an aft position, towards the back of vehicle 10, similar to first row 20. Again, it is contemplated that any apparatus and method for providing horizontal travel of a vehicle seat between a fore position and an aft position can be utilized in accordance with the present invention. Further, the rearmost limit of a seat in second row 28 when translated in the aft position defines the boundary between intermediate cabin 18 and rear cabin 16.

Finally, third row of seats 30, generally located within rear cabin 16, is provided. Preferably at least two seats comprise third row 30. More preferably, three seats comprise third row 30. Third row 30 is generally parallel to and positioned behind second row 28, as illustrated in FIGS. 1a-1d. Like first row 20 and second row 28, each seat in third row 30 may be capable of translating linearly along the vehicle floor between a fore position, towards the front of vehicle 10, and an aft position, towards the back of vehicle 10. It is contemplated that any apparatus and method for providing horizontal travel of a vehicle seat between a fore position and an aft position can be utilized in accordance with the present invention, such as is

known in the seat track art. Further, rear cabin 16 is bounded to the rear by an object such as liftgate 17, or a rear door, or possibly an additional row of seats. It is fully contemplated that additional rows of seats can be provided without limiting the scope of this invention.

Referring now to FIGS. 3a-3c, a seat 34 according to a certain embodiment of the present invention is illustrated. Reversible seat 34 is generally comprised of seat cushion 36 and backrest 38. Seat cushion 36 includes front portion 40, rear portion 42, upper surface 44, and lower surface 46. Seat cushion 36 is operatively coupled to supporting structure 21. Front portion 40 is the portion of seat cushion 36 nearest the front of vehicle 10, while rear portion 42 is the portion of seat cushion 36 nearest the rear of vehicle 10. Preferably, upper surface 44 is contoured to provide lateral support, best shown in FIG. 4a. Moreover, upper surface 44 is generally symmetrical such that front portion 40 and rear portion 42 are substantially similarly contoured to allow an occupant to sit on seat cushion 36 and comfortably face either forward or rearward.

Backrest 38 is coupled to seat cushion 36 such that it is movable between a forward seating position (FIG. 3a) and a rearward seating position (FIG. 3c). The term seat cushion is used herein, but it should be appreciated that the term is intended to include not only the cushion itself but all related structure such as the seat base, rail or anchor. When backrest 38 is adjusted in the forward seating position, adjoining rear portion 42 of seat cushion 36, reversible seat 34 faces forward, as is illustrated in FIG. 3a. When backrest 38 is adjusted in the rearward seating position, adjoining front portion 40 of seat cushion 36, of reversible seat 34 faces rearward, as illustrated in FIG. 3c. Accordingly, the backrest 38 has a front face 48 and a back face 50, which may be substantially similarly contoured and adapted to support an occupant's back which rests thereupon. For example, an occupant in reversible seat 34 is supported by front face 48 of backrest 38 when backrest 38 is in the forward seating position. Alternatively, an occupant in reversible seat 34 is supported by back face 50 of backrest 38 when backrest 38 is in the rearward seating position. Preferably, both front face 48 and back face 50 are contoured to provide lateral support. Therefore, an occupant can comfortably rest in reversible seat 34 while facing rearward without foregoing any of the comfort normally obtained from standard non-reversible automotive seats.

Alternate constructions and designs of a seat back for use in the present invention are further disclosed in FIGS. 6a-6d when the substantial similar contour of the seat back is shown in detail. As shown, the cross section of a seat back 38 includes side lateral supports 39 and center support 41. The lateral supports in 39 and center supports 41 are disposed on both the front face 48 and back face 50 of the seat back 38. As can be appreciated by viewing FIG. 6a, a desirable shape for seat back 38 is contoured to provide lateral support when used in both a forward and a rearward seating position. FIGS. 6a-6b also disclose lumbar support 96 is illustrated within backrest 38. Lumbar support 96 provides varying degrees of back support depending on the preferences of a seat occupant. Lumbar support 96 can provide sufficient support to a user whether seated when backrest 38 is in the forward seating position or rearward seating position. In a certain embodiment, lumbar support 96 comprises bladder 120 and pump and solenoid assembly 122. The solenoid is electrically coupled to rocker switch 124 (shown in FIGS. 4a-4b). The depression of rocker switch 124 in one direction activates pump and solenoid assembly 122, thereby inflating bladder 120. The inflation of bladder 120 causes both front face 48 and back face 50 to extend outward effectuating support for

occupants regardless of whether they face forward or rearward, as depicted in FIG. 6b. Of course, if less support is desired, a user merely depresses rocker switch 124 in the opposite direction to relieve bladder 120.

FIGS. 6c and 6d provide an alternative arrangement for the substantially similarly contoured seat back 38 of FIGS. 6a and 6b. In FIG. 6c, the back face 50 of the seat back 38 is substantially planar. However, front face 48 is appropriately contoured to provide lateral support for the occupant. The construction of the seat back 38 includes a center plate 51 with at least one airbag or bladder 53a, 53b and 53c disposed near the front face the bladders can be inflated to provide the appropriate contour for the front face 48. When in the rearward seating position, illustrated in FIG. 6d, the airbags 53a, 53b and 53c are substantially deflated disposed on the opposing side of the center plate 51 is a second compliment of airbags 55a, 55b and 55c which may be inflated to provide a contour to the back face 50 while the seat is in the rearward seating position. It should be noted that the bladders 53 and 55 can be automatically or manually controlled or adjusted by use of an electric motor.

Returning to FIG. 3a, seating surface 52 is illustrated. Seating surface 52 is the surface created by seat cushion 36 and backrest 38 for supporting an occupant when reversible seat 34 is facing forward. Accordingly, seating surface 52 is generally defined by upper surface 44 and front face 48 of seat back 38 when backrest 38 is in the forward seating position.

Seating surface 52' is illustrated in FIG. 3c. Seating surface 52' is the surface created by seat cushion 36 and backrest 38 for supporting an occupant when reversible seat 34 is facing rearward. As such, seating surface 52' is defined by upper surface 44 and back face 50 when backrest 38 is in the rearward seating position. Seating surface 52' is substantially the mirror image of seating surface 52.

Seat 34 further includes headrest 54 affixed to the top of backrest 38. Preferably, headrest 54 is shaped and positioned to provide adequate support for an occupant's head whether backrest 38 is in the forward seating position or the rearward seating position. Most preferably, headrest 54 is contoured such that it affords an occupant the same comfort and safety regardless of which direction the occupant faces when sitting in reversible seat 34. Alternatively, headrest 54 may rotate about the z-axis. For example, headrest 54 may include a single post 57 extending therefrom. Post 57 may include a plurality of slots 59 for setting the height of headrest 54. Post 57 is disposed to extend into an opening 61 in the seat back 38. Operatively coupled to the seat back 38 is an engagement member 63 that is adapted for insertion into one of said plurality of slots 59. The engaging member 63 is biased toward the post 57 by a spring or other suitable structure so as to firmly maintain the headrest 54 in position. It should be appreciated that post 57 can rotate about a z-axis in accordance with the arrow 167. It should also be appreciated that the plurality of openings 59 extend laterally through post 57 such that when headrest 54 is rotated 180° the engaging member 63 may be also used to position the headrest 54 in the desired height position.

In a certain embodiment, generally illustrated in FIGS. 3a-3c, backrest 38 is slidably movable from a forward seating position to a rearward seating position. Accordingly, backrest 38 is coupled either directly or indirectly (through a related structure) to seat cushion 36 or base by a pair of seat brackets 56, one on either side of reversible seat 34 (see FIG. 4a or 4b). Seat brackets 56 can be either fixedly or pivotally attached to backrest 38 at one end. At the other end, seat bracket 56 is affixed to a pair of laterally spaced guide members 58. Guide members 58 may contact the lower surface 46 of seat cushion

36. The opposing guide members 58 are spaced apart such that each guide member generally runs below a corresponding side of seat cushion 36, as best shown in FIG. 4a. Each guide member 58 extends from first end 60 to second end 62. First end 60 is positioned adjacent front portion 40, while second end 62 is positioned adjacent rear portion 42. Contact members 56 are slidably engaged with guide members 58 by use of a sliding member 64 linking contact members 56 to guide members 58. Sliding member 64 can be a bearing, roller, or the like, that can smoothly travel along guide members 58 from second end 62 corresponding to a forward seating position, to first end 60, corresponding to the rearward seating position. FIG. 3b depicts backrest 38 when sliding from the forward seating position to the rearward seating position at approximately the half-way point of travel.

Guide members 58 can be an arcuate metal track, such as depicted in FIGS. 3a-3c, certain implementations of the present invention may utilize a straight or linear metal track. In either instance, both first ends 60 and second ends 62 may include a locking member 65 for securing backrest 38 in either the forward seating position or the rearward seating position. Locking member 65 prevents backrest 38 from sliding along guide members 58, when it is not desired to do so. Locking member 65 can be a mechanical latch, tether, or the like. Certain locking designs are illustrated in FIGS. 13 and 14. It should be appreciated that instead of using a guide member or related structure to translate the seat back, the seat back may be selectively engageable at a forward position and a rearward position.

FIGS. 13a-13c illustrate a first locking design. As illustrated, the seat bracket 56 includes an action bolt 157 operatively connected thereto. Preferably, the action bolt is formed in a bow-tie shape and is movable from a first position (illustrated in FIG. 13b) and a lock position disclosed in (illustrated in FIG. 13c). The action bolt 157 may cooperate with a reinforced opening formed in the seat cushion 36, or alternatively, stiffening rods 163 formed as part of the seat. Further, it is also contemplated that the action bolt 157 may be attached to the seat cushion and cooperate with a mating hole formed in the seat bracket 56. It also should be appreciated that although the lefthand side of the vehicle seat is illustrated, a similar apparatus is preferably disclosed on the opposing side of the vehicle seat. For simplicity, however, only the lefthand side structure is disclosed in detail herein. It should also be appreciated that action bolt 157 may cooperate with a slot 65 formed in the seat frame structure 67 disposed below seat cushion 38.

An alternative locking mechanism could be accomplished by way of a pivotable latch 69 and attachment bar 71 illustrated in FIGS. 14a and 14b. The pivotable latch 69 is attached to the seat cushion or related structure is disposed to move about a pivot pin 73 having a first lever hand 75 and a second locking hand 77. Second locking hand 77 is disposed to engage with attachment bar 71 to retain backrest 38 in the desired position. It should be appreciated that pivotable latch 69 can be activated manually, or preferably, activated by electric motor automatically when backrest 38 is in the desired forward or rearward seating position.

Also disclosed in FIG. 13a is an alternate sliding member 64 construction. As illustrated, sliding member 64 can be constructed of two formations or rollers to facilitate ease of travel and support of the backrest.

Returning to FIG. 3, in another certain embodiment, reversible seat 34 further comprises biasing member 67. Biasing member 67 is operably connected to guide members 58 to tilt or incline front portion 40 of seat cushion 36 such that front portion 40 is positioned higher than rear portion 42

when backrest 38 is in the forward seating position. Alternatively, biasing member 67 tilts rear portion 42 such that it is positioned higher than front portion 40 when backrest 38 is in the rearward seating position. Biasing member 67 comprises first pivoting cam 68 and second pivoting cam 70. First pivoting cam 68 is coupled between the first ends 60 of guide members 58, while second pivoting cam 70 is coupled between the second ends 62 of guide members 58. Both first pivoting cam 68 and second pivoting cam 70 are generally vertically biased by a spring, coil, or D.C. motor. When sliding member 64 reaches second end 62 of guide member 58, the vertical bias of second pivoting cam 70 is overcome such that second pivoting cam 70 is caused to be rotated to a more horizontal position, as shown in FIG. 3a. Preferably, sliding member 64 contacts and releases the spring, coil, or D.C. motor that vertically biases the second pivoting cam 70. It should be noted that the D.C. motor used for biasing the pivoting cams 68 and 70 can also be used to provide power to translate the vehicle seat fore and aft on the vehicle floor. Moving sliding member 64 away from second end 62 while transitioning backrest 38 from the forward seating position toward the rearward seating position, second pivoting cam 70 returns to its vertically biased position. Once sliding member 64 terminates in first end 60 of guide member 58, the vertical bias of first pivoting cam 68 is overcome, causing first pivoting cam 68 to rotate toward a generally horizontal position, as illustrated in FIG. 3c. Accordingly, first pivoting cam 68 aligns front portion 40 of seat cushion 36 slightly above rear portion 42 when backrest 38 is moved to the forward seating position. Correspondingly, second pivoting cam 70 aligns rear portion 42 of seat cushion 36 slightly above front portion 40 when backrest 38 is moved to the rearward seating position.

An alternate tilting or inclination mechanism is illustrated in FIGS. 3d-3e. The front portion of the seat cushion 40 may be raised by inflating a front bladder 79 via an electric D.C. motor. To lower the front portion 40 of cushion 36, bladder 79 is deflated. The rear portion 42 of cushion 36 can then be raised by inflating a second rear bladder 81 as shown in FIG. 3e. Each bladder 79 and 81 is illustrated as being operated by a separate motor 83 and 85. It should be, however, appreciated that both may be inflated by the use of only one motor. The inflating and deflating of bladders 79 and 81 corresponds to the position of the backrest 38, such that when the backrest 38 is in the forward seating position, front bladder 79 is inflated while rear bladder 81 is deflated providing an inclination such that the front portion 40 of the seat cushion 36 is positioned higher than the rear portion 42 of the seat cushion 36. As the backrest 38 is transitioned to the rearward seating position, the first bladder 79 is deflated and the rear bladder 81 is inflated automatically to provide an inclination such that the rear portion 42 of the seat cushion 36 is positioned higher than the front portion 40 of the seat cushion 36.

FIGS. 3f and 3g illustrate yet another reversing mechanism of the present invention. FIG. 3e includes an illustration of a guide tube 200. The tube is attached at its ends to the seat cushion 36 or related structure. Attachments brackets 202 couple the guide tube to the seat cushion. The backrest 38 includes a seat back bracket 56. The seat back bracket 56 is preferably J-shaped as shown in FIG. 3g. Attached to the seat back bracket 56 is a pair of follower blocks 204 and 206. Follower blocks 204 and 206 are adapted to cooperate with guide tube 200 to provide a track upon which seat back 38 is translated from a forward seating position to a rearward seating position. Seat back bracket 56 also is attached to a screw 208 with a pair of nuts 210. Screw 208 is attached to a DC motor 212. Activation of the motor causes the screw to rotate

which turns around nuts 210 and causes seat back 38 to transition from a rearward seating position to a forward seating position.

In yet another certain embodiment, reversible seat 34 includes armrests 88 pivotally attached to backrest 38 for providing support for an occupant's arms. Preferably, armrests 88 can pivot approximately 180°. As shown in FIG. 3a, armrests 88 are positioned such that it can be utilized when backrest 38 of reversible seat 34 is in the forward seating position. Should an occupant desire to move backrest 38 to the rearward seating position, then armrests 88 can be rotated about a pivot to provide similar arm support, as illustrated in FIG. 3c. Of course, if an occupant does not desire to utilize armrests 88, then the occupant can rotate armrests 88 to a vertical position alongside backrest 38, as depicted in FIG. 3b.

Referring now to FIG. 7, the internal mechanical interaction of armrest 88 and backrest 38 is illustrated. Armrest 88 further comprises armrest stop 89 operably connected to armrest 88. Armrest stop 89 which, in the preferred embodiment, is a mechanical stop formed by pin 140 which extends through two semi-circular circumferential slots 142 in tube 144 fixedly attached to backrest 38. Stop 89 prevents movement of armrest 88 below a generally horizontal plane whether rotated to support the arm of an occupant in the forward or rearward seating position.

With reference to FIGS. 4a-4d, restraint system 72 is preferably a three-point restraint system having lap strap 74 and shoulder strap 76. However, it is fully contemplated that other restraint systems may be available for use in the present invention, such as the 4-point restraint system illustrated in FIG. 4c. Restraint system 72 is fully integrated with backrest 38, and reversible such that it can be utilized when backrest 38 is in either the forward seating position or the rearward seating position. As such, restraint system 72 further comprises lap strap fastener 78 affixed to a bottom corner of backrest 38 and shoulder strap retractor affixed to a top corner of backrest 38. In the present aspect of the invention, shoulder strap retractors have been used for many years. For example, U.S. Pat. No. 5,895,090 discloses a retractor integrated within a seat, and is hereby incorporated by reference. Shoulder strap retractor (disposed within backrest 38) receives the belt through slot 82, best shown in FIG. 4d. Slot 82 extends from the front face 48 of backrest 38 through the side of a collapsible can 89 to the rear face 50 of the backrest. It should be appreciated that shoulder strap 76 can be translated from a first position shown in FIG. 4d to a second position shown in phantom in FIG. 4d for use when the seat backrest is in its rearward facing position.

Another embodiment of a retractor is shown in FIG. 5a where slot 82 is located at its top such that shoulder strap 76 extends and retracts from or near the top of backrest 38. Lap strap 74 is pivotally attached to the side of backrest 38 by lap strap fastener 78. Lap strap 74 and shoulder strap 76 engage seat buckle 84 for securing the lap strap 74 and shoulder strap 76 to a seat latch 87. Preferably, latch 87 is pivotally attached at seat latch fastener 85 to a side of backrest 38 opposite lap strap fastener 78. However, it is fully contemplated that latch 87 can be attached directly to backrest 38, or a similar part movable with backrest 38. When backrest 38 is moved from the forward seating position to the rearward seating position, restraint system 72 is modified from securing an occupant to front face 48 to instead securing an occupant to back face 50. Lap strap 74 and shoulder strap 76 can be reversed so that they extend over backrest 38 proximate back face 50, as is best shown in FIG. 5b. Further, seat latch 87 pivots a sufficient amount to be accessible by an occupant in reversible seat 34

facing rearward for securement to back face 50. Alternatively, the seatbelt retractor may be placed in the lower portion of the backrest 38 such that the lap strap 74 is directed into the backrest 38, preferably at or near the top portion thereof. The slot 82, however, may be pivotally attached via bezel 80 to the backrest 38 such that the bezel may pivot about the backrest to allow the shoulder strap 76 to be positioned on the front face 48 of the backrest when in the forward seating position and on the rear face 50 when the seat is in the rearward facing position as shown in FIG. 5c.

With regard now to FIG. 8, reversible seat 34 contains recline mechanism 86 for reclining backrest 38. Recline mechanism 86 alters the angle between backrest 38 and seat cushion 36 to adjust to the particular preference of each occupant. Moreover, recline mechanism 86 is operable to adjust the angle of backrest 38 in relation to seat cushion 36 when backrest 38 is in either the forward seating position or the rearward seating position. Recline mechanism 86 is comprised of spring coil 130 having a coil first end 132 and a coil second end 134. First end 132 is affixed to backrest 38, while second end 134 is fixed to either the backrest 38 at its pivot point or to a plate 133 extending from the backrest 38. Spring coil 130 vertically biases backrest 38 to an upright position. Rotational movement about a pivot near the base of backrest 38 causes spring coil 130 to extend or contract, depending on whether a user is reclining backrest 34 in the forward seating position or rearward seating position. In either instance, spring coil 130 desires to return backrest 38 to the biased upright and vertical position. Spring coil 130 can include any number of turns as is necessary to provide a sufficient vertical bias. Moreover, it is contemplated that multiple spring coils may be used in conjunction with the present invention. It is also contemplated to provide a stop mechanism 136 to limit the rotational movement of the backrest 38.

Additionally, it is quite common for the backside of a backrest of an automobile seat to contain a pouch for retaining items such as travel maps, books, or other articles commonly associated with travel for the convenience of the passenger immediately behind the particular seat. Typically, such pouches are sewn or permanently attached to the backside of the backrest. However, such a pouch would not be practical for use in conjunction with a reversible seat because it is permanently attached to the backside of a backrest and would make for an uncomfortable surface for an occupant to rest against, particularly if the pouch contains any items. Accordingly, in yet another certain embodiment, reversible pocket 90 is attached to backrest 38 of reversible seat 34, as shown in FIGS. 3a-3b. Reversible pocket 90 is movable from back face 50 to front face 48 to accommodate reversible seat 34 when backrest 38 is in either the forward seating position or rearward seating position, respectively. Pocket 90 is designed to retain articles for travel similar to that of traditional backrest pouches. Pocket 90, for example, can be selectively attached to back face 50 as shown in FIG. 3a, wherein upper strap 92 is secured around headrest 54. Upon moving backrest 38 from the forward seating position to the rearward seating position, lower strap 94 can be disengaged from the base of backrest 38 so that pocket 90 can be rotated such that it rests against front face 48, as shown in FIG. 3c. Once in position, lower strap 94 can then again be secured to the base of backrest 38. It is, of course, fully contemplated that alternative methods for implementing and securing reversible pocket 90 are available, such as attaching pocket 90 to lateral sides 95 of backrest 38 by an elastic material 97 that allows for the pocket 90 to be moved from the front face 48 to the back face 50 and vice

13

versa by stretching the elastic material **97** such that the pocket **90** can be translated over the backrest **38** as shown in FIG. **3b**.

With reference now to FIGS. **2a**, **2b**, and **2c**, a perspective view of interior **12** of vehicle **10** is provided. In a certain embodiment, at least one seat **34** in second row **28** is equipped with a seat travel mechanism for linearly translating the at least one reversible seat **34** to a fore position and to an aft position. The seat travel mechanism, according to this embodiment, is capable of translating the at least one reversible seat to the fore position such that the at least one reversible seat located in second row **20** surpasses the rearward boundary of front cabin **14**, positioning the at least one second row seat between a pair of seats located in first row **20**. As a result, at least a portion of the at least one second row seat resides in front cabin **14**. In this instance, a driver or a passenger in first row **20** can more readily attend to an infant or child occupying the at least one second row seat. Moreover, the at least one second row seat can be reversible seat **34** adaptable between a forward seating position and a rearward seating position. For example, the at least one second row seat translated to the fore position such that a portion of it resides in front cabin **14** can be adapted to the rearward seating position for securing an infant seat thereto.

A mechanism to provide for linearly translating the seat is illustrated in FIGS. **12a-12c**. The translation mechanism includes a base support **140** which preferably includes two mounting structures **142** and **144**. A base track **146** is disposed connecting mounting structures **142** and **144**. A mating seat track **148** is attached either directly or indirectly to seat cushion **36** and may extend the length of the seat cushion **36**. Seat track **148** matingly attaches to base track **146** for linear travel thereon. Vehicle seat **34** can be translated from a fore-position (illustrated in FIG. **12a**) to an aft-position (illustrated in FIG. **12b**). It should also be appreciated that there may be a base track disposed on each lateral side of seat cushion **36**. Likewise, there may be two seat tracks **148** disposed on lateral sides of the seat cushion. Further, seat cushion **36** has disposed therefrom at least one caster **150** used to ensure balance and smooth transition of the vehicle seat **34**. Additionally, the seat may include a second caster **152** disposed near the rear portion **42** of the seat cushion **36**. As illustrated in FIGS. **12a** and **12b**, seat **34** can be translated substantially from a fore-position to an aft-position.

In the present invention, when the seat **34** is in the forward facing position, backrest **38** may be pivoted downward as shown in FIG. **9b** to a position where the backrest **38** is substantially parallel to the vehicle floor **150**. The seat cushion **36** and backrest **38** can then be pivoted such that both are positioned perpendicular to the vehicle floor **150** as shown in FIG. **9d**. If the vehicle seat **34** is positioned in the rearward seating position as shown in FIG. **10a**, the backrest **38** may be pivoted downward in the direction of arrow **152** such that the backrest **38** and seat cushion **36** are both disposed parallel to vehicle floor **150**. The mechanism to recline the backrest **38** to a position parallel with vehicle floor **150** is disclosed in FIG. **8**. Once folded, the seat back and seat cushion may be pivoted such that they are both disposed in a vertical position with respect to the vehicle floor **150** as shown in FIG. **10b**. The mechanism for this adjustment may be identical to the mechanism that provides the translation between seat positions shown in FIGS. **9c** and **9d**.

The present invention provides an improved uniquely versatile vehicle seat. To provide additional functionality and flexibility, the seat disclosed in the present application may be pivoted about its base to provide for a left or right seating position. As shown in FIGS. **15** and **16**, the seat cushion **36** may be pivotally mounted to a seat base **158** having a pivot

14

160 and a plate **162**. The plate **162** is disposed with at least two anchor positions **164** and **166** so that the seat cushion **36** can be rotated 90°. The seat cushion **36** also includes an attached locking structure **168** which may engage **164** or **166**. It should be appreciated that vehicle seat can pivot 90° about pin **160** so that the seat may be translated from a forward facing position to a leftwardly seating position. It should be appreciated that the backrest **38** of the present invention can then be positioned on the opposing side of the seat cushion in a manner disclosed previously primarily with regard to FIGS. **3a-3g** such that a leftwardly facing seat can be modified to a rightwardly facing seat. Additionally, the seat **34** can be positioned such that, if preferable, when in the leftwardly facing position or the rightwardly facing position, the vehicle door cannot be closed nor can the ignition be operated.

Referring back now to FIGS. **1a-1d**, at least one reversible seat **34** is provided in vehicle **10**. Preferably, reversible seat **34** is of the type previously described in detail herein.

In accordance with a certain embodiment of the present invention, the at least one reversible seat **34** is located in second row **28**. Accordingly, the at least one reversible seat **34** can be adapted to face third row **30**, as shown in FIG. **1b**. Preferably, second row **28** comprises a plurality of reversible seats such that each reversible seat **34** can be adapted to face third row **30**. In this embodiment, occupants in second row **28** face occupants in third row **30** facilitating face-to-face communications and easing interaction therebetween. For example, passengers traveling for business purposes can conduct meetings or conferences, while a driver takes them to their destination. Table **98** can be erected between second row **28** and third row **30** to enhance productivity by providing a surface by which to rest business papers or other work materials. In this embodiment, table **98** is similar to a conference table. As another example, families traveling on long road trips, such as during a vacation, may want to create an area for children to interact with one another. If desired, families could use table **98** to have a family meal during a trip. In this embodiment, table **98** is similar to a café table. In a certain embodiment, table **98** includes table base **100**, which is received by a receptacle in the floor of vehicle **10**, affixing table **98** thereto. Alternately, table **98** may not include a base, but rather is attachable to the sides of interior **12** such that it is supported laterally across interior **12** from one side to the other by projections **15** formed on the indoor walls. It is fully contemplated that there are many other reasons and uses for second row **28** to be adapted to face third row **30**, such as common viewing of an entertainment system placed on the side wall of the vehicle in accordance with the teachings of the present invention. Further, the uses suggested for table **98** are merely exemplary, and it is contemplated that alternate uses are available.

Referring now to FIG. **1c**, the at least one seat **34** is located in third row **30**. Accordingly, the at least one reversible seat **34** can be adapted to face rearward such that occupants in third row **30** can peer out the rear of vehicle **10**. It is contemplated that the at least one reversible seat **34** comprises a plurality of reversible seats such that each reversible seat **34** can be adapted to face rearward. In this particular embodiment, children of traveling families can sit in third row **30** and watch the scenery behind vehicle **10** disappear off in the distance. Often, vehicles of the type shown and described herein as vehicle **10** have liftgate **17** for providing access to rear cabin **16**. When vehicle **10** is at rest, passengers can open liftgate **17**, climb into reversible seat **34** located in third row **30**, and enjoy the environment. For example, during a camping trip, while watching sporting events, or while tailgating, passengers can partake in the festivities from third row **30**, with liftgate **17**

15

ajar. In the event the weather becomes inclement, the passengers will be shielded while still having a great seat for enjoying the activities.

Additionally, the at least one seat **34** is located in first row **20**. Accordingly, the at least one reversible seat **34** can be adapted to face second row **28**. Preferably, the at least one reversible seat **34** in first row **20** comprises a plurality of reversible seats such that each reversible seat **34** can be adapted to face second row **28**. In this particular embodiment, a passenger can adjust his seat to face rearward toward the passengers in second row **28** or third row **30**, while the driver remains facing forward to navigate vehicle **10**. When vehicle **10** is not in motion, the driver may also adjust his seat to face rearward toward passengers in second row **28** or third row **30**. However, when vehicle **10** is in motion, the driver's seat is prevented from being adjusted to face rearward by a seat locking device **104**. Seat locking device **104** prevents backrest **38** of the driver's seat from being adjusted to the rearward seating position when the vehicle ignition switch is in the run-start mode. Conversely, seat locking device **104** prevents turning the ignition switch to the run-start mode when backrest **38** of the driver's seat is adjusted in the rearward seating position. Seat locking device **104** can be an electromechanical device, such as a limit switch, proximity switch, or the like, that sends a signal to corresponding locking member **66** when the ignition switch is in the run-start position. Conversely, seat locking device **104** can send a signal to the vehicle's computer to either allow or prevent vehicle **10** from starting, depending on the position of reversible seat **34**. Alternatively, seat locking device could engage the transmission lock so that the engine will only idle to provide HVAC and accessory power to the cabin. However, it is contemplated that the ignition switch may be turned to the accessory mode regardless of driver seat position.

Although the at least one reversible seat **34** is shown and described in either first row **20**, second row **28** or third row **30**, it is fully contemplated that the at least one reversible seat **34** can be located in first row **20**, second row **28** and third row **30**. Moreover, it is preferable that each seat in vehicle **10** comprises reversible seat **34**.

Although reversible seat **34** provides for flexible seating within vehicle **10** for a multitude of travel situations standard on most vehicles today are airbags, both for driver and passenger, to protect in the event of a collision. These airbags are designed to be deployed when an occupant is facing forward toward the front of a vehicle. It may be unnecessary to deploy an airbag while an occupant faces rearward. Accordingly, each reversible seat **34** is equipped with airbag deactivation device **106**. Airbag deactivation device **106** enables an airbag to be deployed upon collision when backrest **38** of reversible seat **34** is in the forward position. However, when reversible seat **34** is adjusted such that backrest **38** is in the rearward seating position, airbag deactivation device **106** disables the airbag. Airbag deactivation device **106** controls only the airbags corresponding to the reversible seat **34** to which the device is attached, but may be designed to correspond to a multitude of seating arrangements. Moreover, it is contemplated that airbag deactivation device **106** can enable one or more airbags, while disabling one or more other airbags, when reversible seat **34** is in the forward seating position. Upon adjusting reversible seat **34** to the rearward seating position, the previously enabled airbags become disabled, while the previously disabled airbags become enabled.

Airbag deactivation device **106** can be any device that senses the position of backrest **38** and can differentiate between backrest **38** being in the forward seating position or the rearward seating position, such as a limit switch or a

16

proximity sensor, or the like. Airbag deactivation device **106** then sends an appropriate signal to the control unit of the airbag enabling or disabling the airbag. Airbag deactivation device **106** can be used in conjunction with seat locking device **104** to send signals to the appropriate modules. Moreover, it is contemplated that seat locking device **104** is the same as airbag deactivation device **106**.

Primarily in the second row of seats **28**, there may be a need to reposition the seat to facilitate the ingress and egress of a third row passenger. Illustrated in FIGS. **9** and **10** are alternative mechanisms to facilitate the ingress and egress. Various multi-positional seats are known in the art such as the "Multi-positional Seat Mounting Apparatus" of U.S. Pat. No. 6,000,742 which is incorporated herein by reference.

While the best mode for carrying out the invention has been described in detail, those familiar with the art to which this invention relates will recognize various alternative designs and embodiments for practicing the invention as defined by the following claims.

What is claimed:

1. A vehicle interior including a plurality of seats translatable along a vehicle floor from a fore position to an aft position, said vehicle interior comprising:

first row seats located within a front cabin of the vehicle interior, said front cabin having a rearward limit defined by the aft position of at least one of said first row seats; and

second row seats;

wherein at least one of said second row seats translates to the fore position where at least a portion of said at least one of said second row seats is disposed in said front cabin of the vehicle interior;

wherein the at least one second row seat includes a seat cushion and a backrest adaptable between a forward seating position and a rearward seating position, the backrest adjoining a rear portion of the seat cushion when in the forward seating position and a front portion of the seat cushion when in the rearward seating position; and

wherein the at least one second row seat includes a lap and shoulder restraint system integrated with the backrest for use with either the front face or the back face of said backrest.

2. The vehicle interior of claim **1**, further comprising:

third row seats disposed generally behind said second row seats;

wherein at least one third row seat includes a seat cushion and a backrest adaptable between a forward seating position and a rearward seating position, the backrest adjoining a rear portion of the seat cushion when in the forward seating position and a front portion of the seat cushion when in the rearward seating position.

3. The vehicle interior of claim **2**, wherein said at least one third row seat is accessible via a vehicle tailgate when in the rearward seating position.

4. The invention according to claim **1**, wherein said backrest includes a front face and a back face, said back face contoured similar to said front face.

5. The invention according to claim **1**, wherein said backrest has a horizontal cross section having two lateral sides and a midsection therebetween, wherein said cross section is wider at each lateral side than in the midsection.

6. An automotive vehicle having a seating arrangement system, the vehicle comprising:

an interior having a front cabin adjacent a vehicle dashboard, a rear cabin adjacent a vehicle liftgate, and an intermediate cabin interposed therebetween;

17

a first row of seats generally located within the front cabin of the interior and arranged laterally across said vehicle; a second row of seats generally parallel to and positioned behind the first row, the second row generally located within the intermediate cabin of the interior;

at least one reversible seat having a seat cushion and a backrest movable between a forward seating position and a rearward seating position;

a third row of seats generally parallel to and positioned behind the second row, the third row generally located within the rear cabin of the interior;

wherein the at least one reversible seat is located in the second row such that the at least one reversible seat can be adjusted so that the backrest is in the rearward seating position; and

a table interposed between the second row and the third row, and mounted directly to the interior independent of the second row and the third row.

7. The vehicle of claim 6, wherein the interior includes a receptacle oriented in a floor of the interior between the second row and the third row; and

wherein the vehicle further comprises a base mounted to the table and sized to be received in the receptacle for supporting the table on the floor of the interior.

8. The vehicle of claim 6, wherein the interior includes a series of projections extending inward from indoor walls of the interior for receiving and laterally supporting the table.

9. An automotive vehicle having a seating arrangement system, the vehicle comprising:

an interior having a front cabin adjacent a vehicle dashboard, a rear cabin adjacent a vehicle liftgate, and an intermediate cabin interposed therebetween;

a first row of seats generally located within the front cabin of the interior and arranged laterally across said vehicle; a second row of seats generally parallel to and positioned behind the first row, the second row generally located within the intermediate cabin of the interior; and

at least one reversible seat having a seat cushion and a backrest movable between a forward seating position where the backrest is adjacent a rear portion of the seat cushion and a rearward seating position where the backrest is adjacent a front portion of the seat cushion, the reversible seat including a two-way lap and shoulder restraint system integrated with the backrest for use in connection with either a front face or a back face of said backrest.

10. The automotive vehicle of claim 9, further comprising a third row of seats generally parallel to and positioned behind the second row, the third row generally located within the rear cabin of the interior.

11. The vehicle of claim 10, wherein the at least one reversible seat is located in the second row such that the at least one reversible seat can be adjusted so that the backrest is in the rearward seating position allowing a second row occupant to face the third row of seats.

12. The vehicle of claim 10, wherein the at least one reversible seat is located in the third row such that the at least one reversible seat can be adjusted so that the backrest is in the rearward seating position.

13. The vehicle of claim 12, further comprising a table surface interposed between the second row and the third row.

14. The vehicle of claim 9, wherein said first row includes a driver's seat and a passenger seat, and wherein said at least one reversible seat is said passenger seat which can be adjusted so that the backrest is in the rearward seating position allowing a first row occupant to face the second row of seats.

18

15. The vehicle of claim 14, further comprising a deactivation switch in cooperation with said passenger seat, such that when said passenger seat is in said rearward seating position the deactivation switch is actuated thereby deactivating a passenger airbag of the vehicle.

16. The vehicle of claim 9, wherein said first row includes a driver's seat and a passenger seat, and wherein said at least one reversible seat is said driver's seat.

17. The vehicle of claim 16, further comprising a locking device in cooperation with the driver's seat, such that the backrest of the driver's seat is prevented from being adjusted to the rearward seating position when a vehicle ignition switch is in a run-start position, and the vehicle ignition switch is prevented from being adjusted to the run-start position when the backrest of the driver's seat is in the rearward seating position.

18. The vehicle of claim 9, wherein said front face includes front lateral supports for use when the backrest is in the forward seating position, and said back face includes rear lateral supports for use when the backrest is in the rearward seating position.

19. The vehicle of claim 9, wherein the at least one reversible seat further comprises:

a guide member affixed to the seat cushion, said guide member extending from a first end adjacent the front portion to a second end adjacent the rear portion;

a seat bracket slidably engaged with said guide member, the backrest being coupled to the seat cushion by said seat bracket and slidably movable along the guide members between the forward seating position when the backrest adjoins the rear portion and the rearward seating position when the backrest adjoins the front portion; and

a biasing member operably connected to said guide member to tilt said front seating portion of said seat cushion such that said front portion is positioned higher than said rear portion when in said forward seating position;

wherein said biasing member further comprises a first pivoting cam coupled to said guide member near said first end, wherein said first cam is positioned to tilt said front portion of the seat cushion above the rear portion when said backrest is in said forward seating position.

20. The vehicle of claim 9, wherein the at least one reversible seat further comprises:

a guide member affixed to the seat cushion, said guide member extending from a first end adjacent the front portion to a second end adjacent the rear portion;

a seat bracket slidably engaged with said guide member, the backrest being coupled to the seat cushion by said seat bracket and slidably movable along the guide member between the forward seating position when the backrest adjoins the rear portion and the rearward seating position when the backrest adjoins the front portion;

a biasing member operably connected to said guide member to tilt said front seating portion of said seat cushion such that said front portion is positioned higher than said rear portion when in said forward seating position; and

a locking member at each end of said guide member for securing the backrest in either the forward seating position or the rearward seating position.

21. An automotive vehicle having a seating arrangement system, the vehicle comprising:

an interior having a front cabin adjacent a vehicle dashboard, a rear cabin adjacent a vehicle liftgate, and an intermediate cabin interposed therebetween;

19

a first row of seats generally located within the front cabin of the interior and arranged laterally across said vehicle wherein said first row includes a driver's seat and a passenger seat;
a second row of seats generally parallel to and positioned 5 behind the first row, the second row generally located within the intermediate cabin of the interior;
at least one reversible seat having a seat cushion and a backrest movable between a forward seating position and a rearward seating position wherein said at least one

20

reversible seat is said passenger seat which can be adjusted so that the backrest is in the rearward seating position allowing a first row occupant to face the second row of seats; and
a deactivation switch in cooperation with said passenger seat, such that when said passenger seat is in said rearward seating position the deactivation switch is actuated thereby deactivating a passenger airbag of the vehicle.

* * * * *