



- (51) International Patent Classification:
F16J 10/04 (2006.01) *C23C 26/00* (2006.01)
B24B 1/00 (2006.01)
- (21) International Application Number: PCT/EP2014/074513
- (22) International Filing Date: 13 November 2014 (13.11.2014)
- (25) Filing Language: English
- (26) Publication Language: English
- (30) Priority Data:
10 2013 030435 2
27 November 2013 (27.11.2013) BR
- (71) Applicants: MAHLE METAL LEVE S/A [BR/BR]; Rodovia Anhanguera, sentido interior - capital, Km 49,7, CEP-13210-877 Jundiaí, SP (BR). MAHLE INTERNATIONAL GMBH [DE/DE]; Pragstraße 26-46, 70376 Stuttgart (DE). APPLIED NANO SURFACES SWEDEN AB [SE/SE]; Knivstagan 12, S-753 23 Uppsala (SE).
- (72) Inventors: MEIRELLES TOMANIK, Antonio Eduardo; Rua Joao de Souza Dias, 854, apto 72, CEP-04618-003 Sao Paulo, SP (BR). ZHMUD, Boris; Knivstagan 12, S-753 23 Uppsala (SE). KOLAR, Christian; Knivstagan 12, S-753 23 Uppsala (SE). GRANLUND, Mattias; Knivstagan 12, S-753 23 Uppsala (SE).
- (74) Agent: BRP RENAUD UND PARTNER MBB; Königstraße 28, 70173 Stuttgart (DE).
- (81) Designated States (unless otherwise indicated, for every kind of national protection available): AE, AG, AL, AM, AO, AT, AU, AZ, BA, BB, BG, BH, BN, BR, BW, BY, BZ, CA, CH, CL, CN, CO, CR, CU, CZ, DE, DK, DM, DO, DZ, EC, EE, EG, ES, FI, GB, GD, GE, GH, GM, GT, HN, HR, HU, ID, IL, IN, IR, IS, JP, KE, KG, KN, KP, KR, KZ, LA, LC, LK, LR, LS, LU, LY, MA, MD, ME, MG, MK, MN, MW, MX, MY, MZ, NA, NG, NI, NO, NZ, OM, PA, PE, PG, PH, PL, PT, QA, RO, RS, RU, RW, SA, SC, SD, SE, SG, SK, SL, SM, ST, SV, SY, TH, TJ, TM, TN, TR, TT, TZ, UA, UG, US, UZ, VC, VN, ZA, ZM, ZW.

[Continued on next page]

- (54) Title: METHOD FOR THE TRIBOMECHANICAL CONDITIONING OF A THIN-WALLED CYLINDER/LINER, AND CYLINDER/LINER

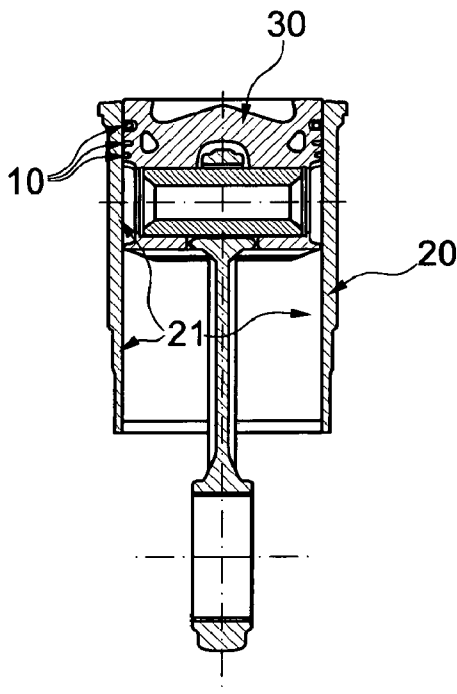

Fig. 1

(57) Abstract: The present invention relates to a method for the lining of a thin-walled sliding element (20) for internal combustion engine blocks in which: (i) the pressure applied for honing the sliding element (20) is between 8 MPa and 9 MPa; and (ii) at least a part of the inner surface (21) of the sliding element (20) comprises a nano-coat of solid lubricant provided with roughnesses, before honing, of Rpk, Rk and Rvk no lower than 2/3 of the original.



- (84) Designated States** (*unless otherwise indicated, for every kind of regional protection available*): ARIPO (BW, GH, GM, KE, LR, LS, MW, MZ, NA, RW, SD, SL, ST, SZ, TZ, UG, ZM, ZW), Eurasian (AM, AZ, BY, KG, KZ, RU, TJ, TM), European (AL, AT, BE, BG, CH, CY, CZ, DE, DK, EE, ES, FI, FR, GB, GR, HR, HU, IE, IS, IT, LT, LU, LV, MC, MK, MT, NL, NO, PL, PT, RO, RS, SE, SI, SK, SM, TR), OAPI (BF, BJ, CF, CG, CI, CM, GA, GN, GQ, GW, KM, ML, MR, NE, SN, TD, TG).
- Published:**
- *with international search report (Art. 21(3))*
 - *before the expiration of the time limit for amending the claims and to be republished in the event of receipt of amendments (Rule 48.2(h))*

"METHOD FOR
THE TRIBOMECHANICAL CONDITIONING OF A THIN-WALLED
CYLINDER/LINER, AND CYLINDER/LINER".

The present invention relates to a method for the tribomechanical conditioning of a thin-walled conditioning of a thin-walled cylinder/liner for use in particular in an internal combustion engine block.

DESCRIPTION OF THE STATE OF THE ART

There is currently a growing demand for engine materials and/or components which offer greater wear resistance and reduced friction. With respect to the automotive sector, and more specifically the lining and/or treatment of surfaces of combustion engine cylinders/bores, recent research has been developed with a view to obtaining surface materials and finishes which contribute to a reduction in fuel consumption, and consequently CO₂ emissions, through reduced losses due to friction. Solutions involving nanotechnology have been the particular focus of recent research.

A possible solution is described in the patent document EP 2 229 467 which describes a method for manufacturing a mechanical element, such as an engine component, which has a surface of reduced friction which has a tribochemical conditioning/deposition of a substance such as a solid lubricant, which covers the surface of the element.

Patent document CA 2 704 078 is very similar to the above European document and relates to the process for manufacturing a low friction element by tribochemically conditioning a solid lubricant, specifying the application of the solid lubricant to an engine cylinder liner.

Finally, patent document US 2010/0272942, of the same family of both of the above-mentioned documents, relates to a similar manufacturing process, with the emphasis on its use in cylinder liners and engine block cylinders.

The three patent documents mentioned relate to a dedicated metal mechanical process which combines the extreme mechanical pressure of honing the surface of the component with the tribochemical or mechanicochemical deposition of the anti-wear film of low friction tungsten disulphate (WS_2).

Despite the advantages of reducing friction and wear in liners/cylinder, the extreme pressure applied during the tribomechanical conditioning used in the above-mentioned technique, may deform the liner/cylinder from its ideal circular shape in the thin-walled blocks normally used in low weight engine blocks. To prevent the increase in the consumption of lubricating oil in the aforementioned bore/cylinder of deformed engine blocks, use must be made of piston rings with higher forces, which jeopardises the reduction in friction.

With a view to minimising the above-mentioned reduction in friction when piston rings with a higher load is used, the original roughness of the bore/cylinder of the blocks may be reduced, which may not be desirable. This is due to the fact that some degree of roughness is desirable since the roughness may serve as a lubricating oil reservoir, thus enabling the parts, the piston rig and block bore/cylinder, soften in the first few hours of operation of the engine.

For the purpose of overcoming such limitations, the inventors have developed an improved tribomechanical conditioning process by using low pressure during the honing process yet still achieving a significant reduction in friction according to the description below.

OBJECTIVES OF THE INVENTION

The objective of the present invention is to provide a method for the tribomechanical conditioning of a thin-walled sliding element for internal combustion engine blocks to ensure a reduction in the fuel consumption of the engine and low deformation of the same.

BRIEF DESCRIPTION OF THE INVENTION

The objectives of the invention are achieved by a method for the tribomechanical conditioning of a thin-walled liner/cylinder for internal combustion engine blocks in which:

- (i) the pressure applied for honing the sliding element is between 5 MP and 15 MPa; and
- (ii) at least part of the inner surface of the sliding element, comprises a nano-coat of solid lubricant, provided with roughnesses, before honing, of R_{pk} , R_k and R_{vk} no lower than 2/3 of the original.

BRIEF DESCRIPTION OF THE DRAWINGS

The present invention will be described in more detail on the basis of embodiments shown in the drawings. In the figures:

Figure 1 shows a schematic view of the sliding element for use in an internal combustion engine covered by this invention;

Figure 2 shows the result of FMEP measurement (comparative test) between the standard cylinder (base or baseline) and the cylinder with tribomechanical condition;

Figure 3 shows the result of the comparative test between the standard liner (base or baseline) and the liner with tribomechanical conditioning under the force of friction and combustion pressure at 2500 rpm at 0.93 MPa (9.3 bars).

Figure 4 shows the result of the comparative test for loss due to friction between the standard liner (base or baseline) and the liner with tribomechanical conditioning;

Figure 5 shows a schematic view of the thin-walled liner sliding element for use in an internal combustion engine covered by this invention, as tested in an engine with a floating liner.

DETAILED DESCRIPTION OF THE FIGURES

As described in the description of the state of the art, a tungsten disulphide (WS) lining for minimising the reduction in friction between the tribo system, piston rings 10, liner/cylinder 20 and piston 3, and tribomechanical conditioning by honing, are already

known, but this solution, which impacts the oil/gas seal of the tribo system referred to due to possible deformations if the cylinder has thin walls, between 1.6 mm and 5 mm.

This invention eliminates the problem referred to by using a low pressure, high speed honing process which provides a surface adequate for reducing friction whilst at the same time providing a low/reduced deformation of a thin-walled sliding element 20. It is worth mentioning that the sliding element 20 referred to may be a cylinder liner or even an engine block cylinder/bore.

It should be noted that the process makes it possible to work at a lower pressure since longer tools have been

created and even having a slightly slower process is compensated for by the lower pressure. It should also be noted that if the same length of tool were to be used in the tribomechanical conditioning process, the process time would be 50% longer with this configuration. Even with a longer process time the surface will still have sufficient roughnesses in contact with the others, between the tool and the part, to form the tribo film and obtain an improvement in the roughness of the surface.

Table I below demonstrates the roughness values found before and after said process, where it is observed that unlike in the state of the art documents, the roughness is slightly reduced.

	Original	After process
Rpk	0.13	0.10
Rk	0.53	0.48
Rvk	1.81	1.86

Table I - Pre- and post-treatment roughnesses

Table II shows the characteristics of the test used for confirming the low pressure treatment.

Type of engine	Single cylinder, 4-stroke SI
Displacement (litres)	0.65
Diameter x stroke (mm)	96 x 89.2
Compression Rate	9.7
Operating Conditions (Speed and IMEP)	1300 rpm @ 0.53 MPa 5.3 bars, 0.83 MPa (8.3 bars) 2500 rpm @ 0.63 MPa (6.3 bars), 0.93 MPa (9.3 bars)

Table II - Characteristics of the Floating Liner test

Figure 2 shows the friction mean effective pressure (FMEP) measurement in each regime. The liner with tribomechanical conditioning (b) had a FMEP reduction of 5 to 11%. For repetition, the standard liner (baseline - a) also showed a reduction, but much smaller compared to the sliding element 20 with tribomechanical conditioning (b). The small FMEP reduction in the repetition of standard liner (baseline - a) is due to the fact that there is a transfer from the tribological layer of the lining to the rings and to the piston chamber. This hypothesis will be investigated in future tests. The fuel saving in each operating condition may be estimated as $(\Delta \text{ FMEP} / \text{IMEP})$, which would give a fuel saving of 0.13-0.27%.

The floating liner test enables the frictional forces along the stroke to be resolved. Figure 3 shows a comparison between the standard liner (base/baseline - a) and liner 20 with tribomechanical conditioning (b) under the condition of frictional force and fuel pressure at 2500 rpm at 0.93 MPa (9.3 bars), where the force is measured along the travel of the crank. As expected, major reductions in friction occurred in the course of expansion, particularly loss of the upper point of reversal, where the fuel pressures are highest and the speeds lowest, which leads to a boundary lubrication regime.

In terms of fuel saving, the losses by friction are more important than the forces of attrition. Figure 4 shows the instantaneous FMEP at each angle of the crankshaft. It is possible to establish from Figure 4 that the greatest FMEP reductions occurred between the angles of 20° and 60°, but in practice this occurs throughout the piston stroke. As discussed in the reciprocal tests, the tribo layer (b) appears to have a beneficial effect, even under conditions where the speeds are highest and the lubrication regime has a hydrodynamic tendency.

After the test liner 20 with tribomechanical conditioning (b) was cut and its topography measured in three positions 1, 2, 3 along the stroke of the rings. As can be seen in Figure 5, the lower region 3, outside the piston stroke, was assumed to be representative of the new condition. In mid strike 2, the topography was found to be almost unaltered. It was therefore concluded that the tribo layer was preserved, which would allow the preservation/maintenance of the reduction in friction. At the points of reversal, as expected, greater wear was found, which demonstrates that the tribo layer could have been removed, but although the forces of friction are high at the points of inversion, the speeds are low and there are even losses due to friction.

Table III shows the different values of the roughnesses found in regions 1, 2 and 3 in Figure 5.

	1	2	3
Rpk	0.07	0.09	0.14
Rk	0.22	0.45	0.26
Rvk	0.66	0.90	1.3

Table III - Roughnesses after test

In addition, after microscopic analysis of liners 20, with tribomechanical conditioning (b), it was possible to observe the presence of tungsten on the surface.

The invention therefore relates to a sliding element obtained by the method just defined.

Now that preferred embodiments have now been described, it should be understood that the scope of the present invention extends to other possible variations limited only

by the content of the attached claims, which include the possible equivalents.

CLAIMS

1. Method for the tribomechanical conditioning of the liner/cylinder of thin-walled blocks (2) for internal combustion engines, characterised in that:
 - (i) the pressure applied for honing the sliding element of thin-walled blocks (2) is between 5 MPa and 15 MPa; and;
 - (ii) at least one part of the inner surface (21) of the sliding element of thin-walled blocks (2) comprises a nano layer of solid lubricant, provided with roughnesses, before honing, of R_{pk} , R_k and R_{vk} no less than $2/3$ of the original.
2. Sliding element, characterised in that it is obtained by the method described in Claim 1.

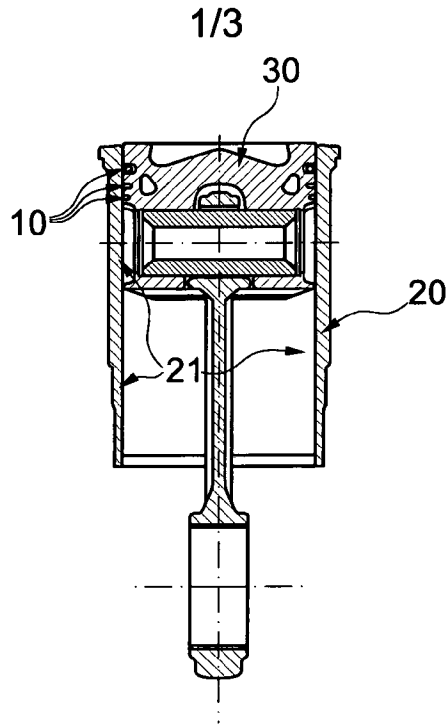

Fig. 1

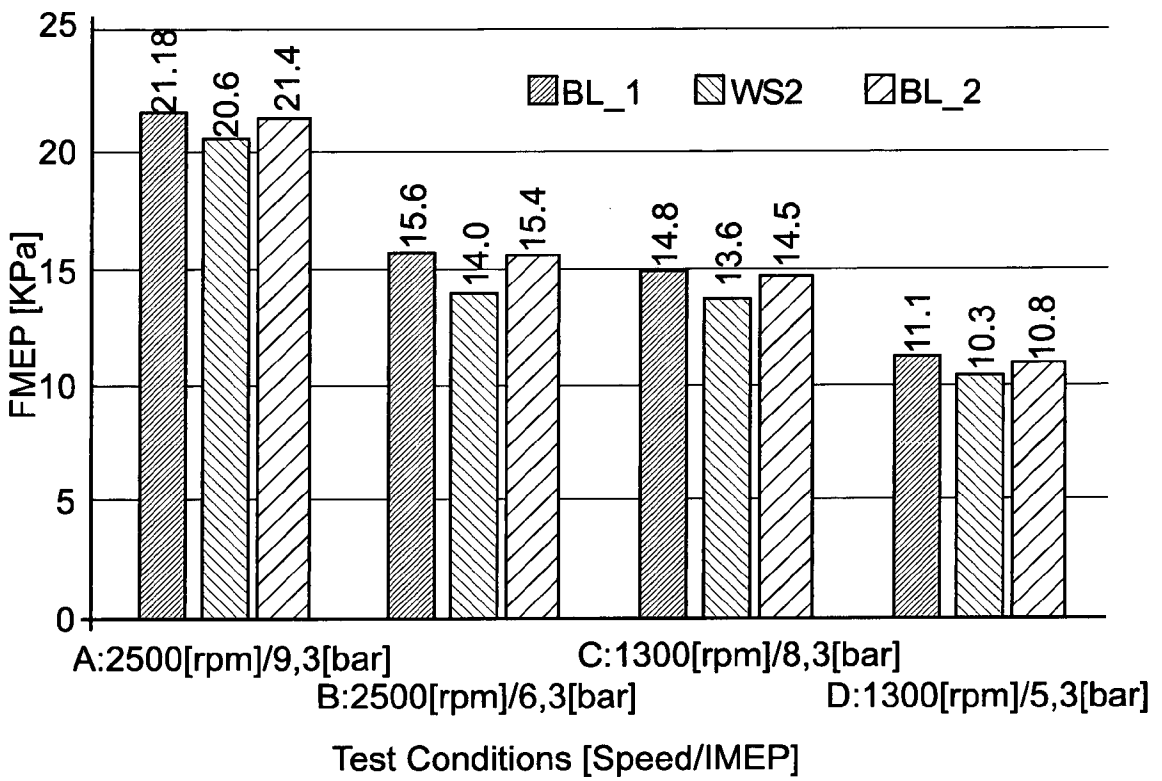

Fig. 2

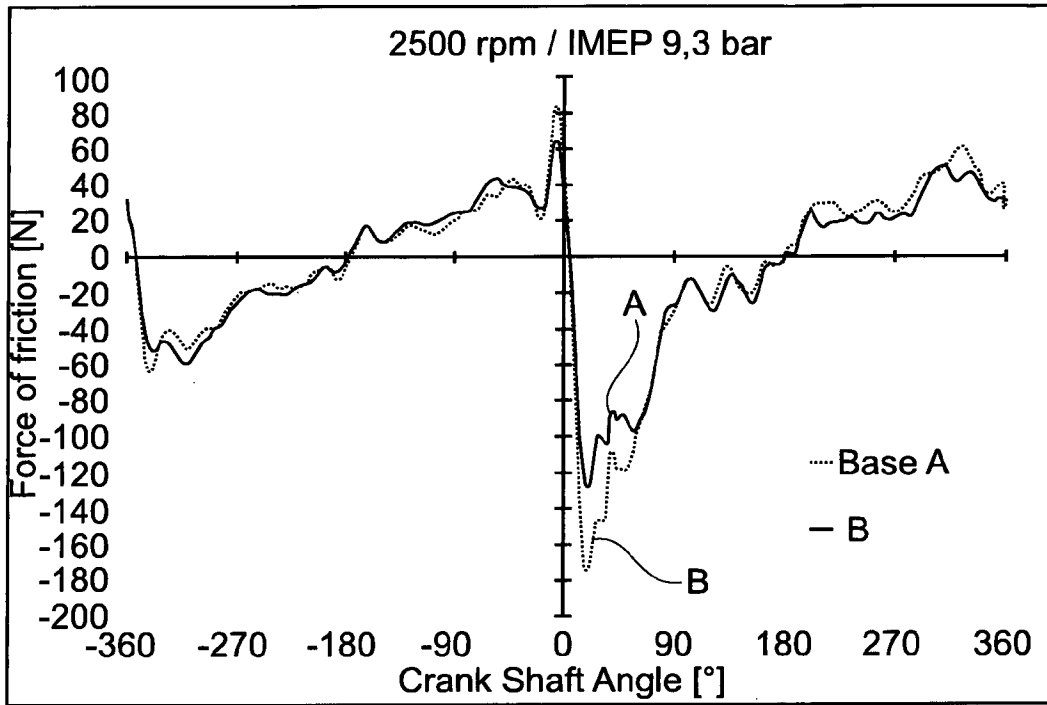

Fig. 3

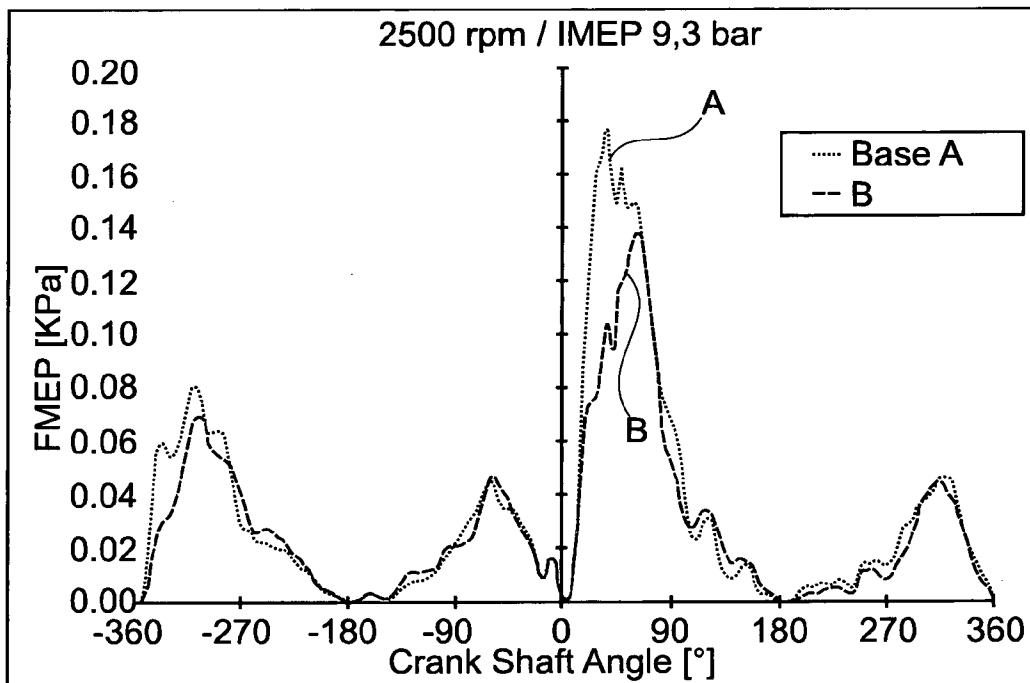

Fig. 4

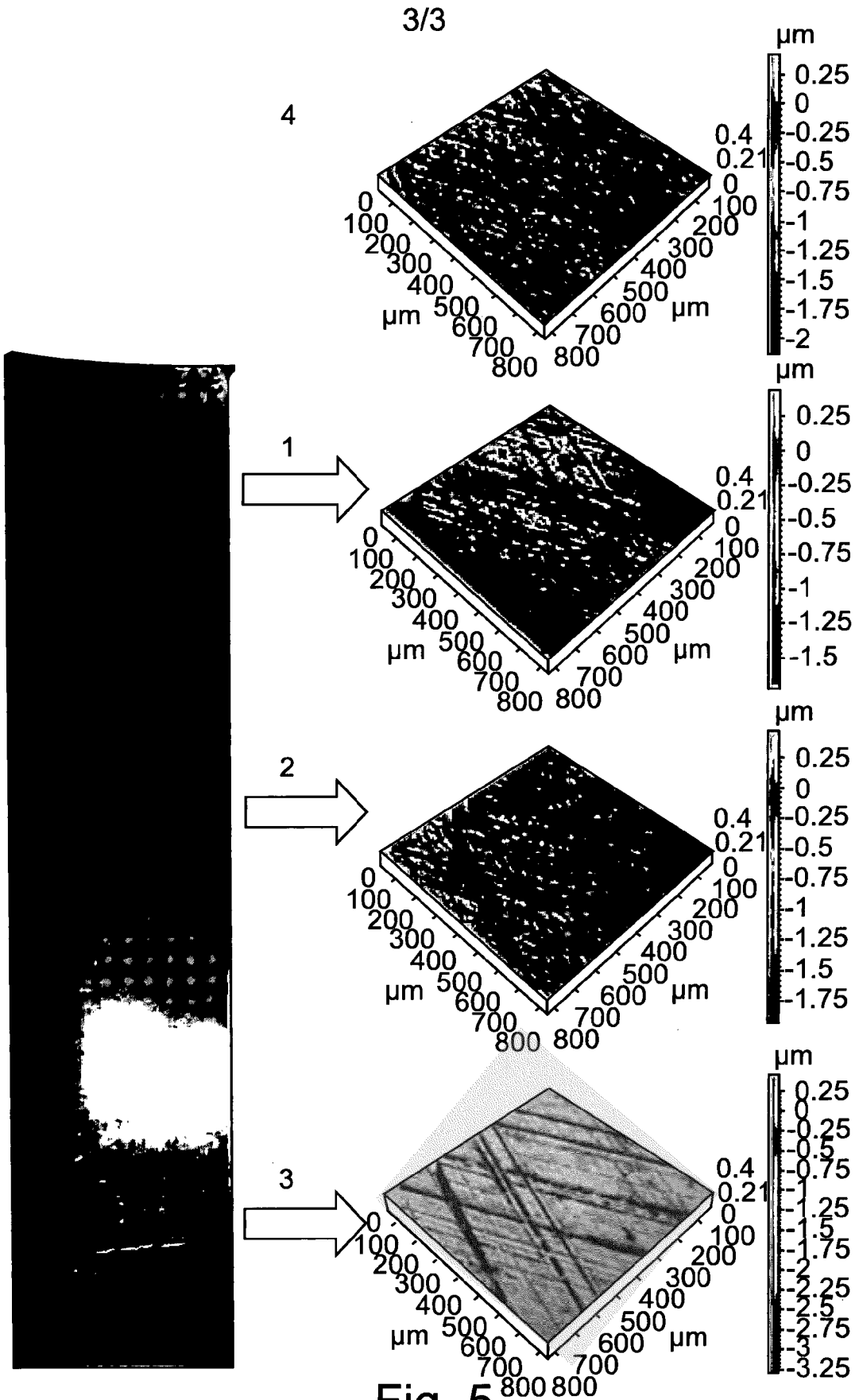

Fig. 5

INTERNATIONAL SEARCH REPORT

International application No
PCT/EP2014/074513

A. CLASSIFICATION OF SUBJECT MATTER
 INV. F16J10/04 B24B1/00 C23C26/00
 ADD.

According to International Patent Classification (IPC) or to both national classification and IPC

B. FIELDS SEARCHED
 Minimum documentation searched (classification system followed by classification symbols)
 F16J B24B C23C C10M F02F

Documentation searched other than minimum documentation to the extent that such documents are included in the fields searched

Electronic data base consulted during the international search (name of data base and, where practicable, search terms used)
 EPO-Internal, WPI Data

Category*	Citation of document, with indication, where appropriate, of the relevant passages	Relevant to claim No.
X	WO 2012/008890 A1 (APPLIED NANO SURFACES SWEDEN AB [SE]; ZHMUD BORIS [SE]) 19 January 2012 (2012-01-19)	1,2
Y	page 9, line 13 - line 20; claim 1; figures 1C,2,3	1,2
Y	----- EP 2 229 467 A2 (APPLIED NANO SURFACES SWEDEN A [SE] APPLIED NANO SURFACES SWEDEN AB [S]) 22 September 2010 (2010-09-22) cited in the application paragraph [0023] - paragraph [0025]	1,2
A	----- EP 2 441 549 A2 (MAN TRUCK & BUS AG [DE]) 18 April 2012 (2012-04-18) paragraph [0019]; figure 1	1,2
A	----- US 2003/192501 A1 (ISHIKAWA YOSHIKI [JP] ET AL) 16 October 2003 (2003-10-16) paragraph [0029] - paragraph [0038]	1,2

Further documents are listed in the continuation of Box C.

See patent family annex.

* Special categories of cited documents :

<p>"A" document defining the general state of the art which is not considered to be of particular relevance</p> <p>"E" earlier application or patent but published on or after the international filing date</p> <p>"L" document which may throw doubts on priority claim(s) or which is cited to establish the publication date of another citation or other special reason (as specified)</p> <p>"O" document referring to an oral disclosure, use, exhibition or other means</p> <p>"P" document published prior to the international filing date but later than the priority date claimed</p>	<p>"T" later document published after the international filing date or priority date and not in conflict with the application but cited to understand the principle or theory underlying the invention</p> <p>"X" document of particular relevance; the claimed invention cannot be considered novel or cannot be considered to involve an inventive step when the document is taken alone</p> <p>"Y" document of particular relevance; the claimed invention cannot be considered to involve an inventive step when the document is combined with one or more other such documents, such combination being obvious to a person skilled in the art</p> <p>"&" document member of the same patent family</p>
---	---

Date of the actual completion of the international search 17 March 2015	Date of mailing of the international search report 26/03/2015
--	--

Name and mailing address of the ISA/ European Patent Office, P.B. 5818 Patentlaan 2 NL - 2280 HV Rijswijk Tel. (+31-70) 340-2040, Fax: (+31-70) 340-3016	Authorized officer Kornmeier, Martin
--	---

INTERNATIONAL SEARCH REPORT

Information on patent family members

International application No

PCT/EP2014/074513

Patent document cited in search report	Publication date	Patent family member(s)	Publication date
WO 2012008890 A1	19-01-2012	CA 2804158 A1	19-01-2012
		CN 103097578 A	08-05-2013
		EA 201390048 A1	30-07-2013
		EP 2593581 A1	22-05-2013
		JP 2013531118 A	01-08-2013
		KR 20130110150 A	08-10-2013
		US 2013104357 A1	02-05-2013
		WO 2012008890 A1	19-01-2012
		EP 2229467 A2	22-09-2010
CN 101918612 A	15-12-2010		
EA 201000925 A1	30-12-2010		
EP 2229467 A2	22-09-2010		
ES 2391362 T3	23-11-2012		
JP 2011506760 A	03-03-2011		
KR 20100102617 A	24-09-2010		
PL 2229467 T3	30-11-2012		
US 2010272931 A1	28-10-2010		
WO 2009071674 A2	11-06-2009		
EP 2441549 A2	18-04-2012	CN 102554755 A	11-07-2012
		DE 102010048550 A1	19-04-2012
		EP 2441549 A2	18-04-2012
		RU 2011141569 A	20-04-2013
		US 2012090570 A1	19-04-2012
US 2003192501 A1	16-10-2003	DE 10312227 A1	23-10-2003
		JP 3821219 B2	13-09-2006
		JP 2003286895 A	10-10-2003
		KR 20030077967 A	04-10-2003
		US 2003192501 A1	16-10-2003