



US 20170074539A1

(19) **United States**

(12) **Patent Application Publication**
Bentz et al.

(10) **Pub. No.: US 2017/0074539 A1**

(43) **Pub. Date: Mar. 16, 2017**

(54) **THERMOSTAT WITH OCCUPANCY
DETECTION BASED ON LOAD OF HVAC
EQUIPMENT**

(71) Applicant: **Johnson Controls Technology
Company**, Plymouth, MI (US)

(72) Inventors: **Jedidiah O. Bentz**, Wichita, KS (US);
Brian D. Rigg, Douglass, KS (US);
Theresa N. Gillette, Wichita, KS (US);
Tom R. Tasker, Andover, KS (US);
Tyler McCune, El Dorado, KS (US);
John W. Uerkvitz, Valley Center, KS
(US); **Shaun B. Atchison**, Wichita, KS
(US); **Daniel S. Middleton**, Wichita,
KS (US); **Aneek Muhammad Noor**,
Wichita, KS (US); **William P. Alberth,**
JR., Prairie Grove, IL (US); **Joseph R.**
Ribbich, Waukesha, IL (US)

(73) Assignee: **Johnson Controls Technology
Company**, Plymouth, MI (US)

(21) Appl. No.: **15/260,294**

(22) Filed: **Sep. 8, 2016**

Related U.S. Application Data

(60) Provisional application No. 62/217,789, filed on Sep. 11, 2015, provisional application No. 62/217,791, filed on Sep. 11, 2015, provisional application No. 62/217,788, filed on Sep. 11, 2015, provisional application No. 62/217,790, filed on Sep. 11, 2015, provisional application No. 62/367,597, filed on Jul. 27, 2016, provisional application No. 62/367,614, filed on Jul. 27, 2016, provisional application No. 62/367,297, filed on Jul. 27, 2016, provisional appli-

cation No. 62/367,315, filed on Jul. 27, 2016, provisional application No. 62/367,291, filed on Jul. 27, 2016, provisional application No. 62/247,672, filed on Oct. 28, 2015, provisional application No. 62/275,711, filed on Jan. 6, 2016, provisional application No. 62/367,621, filed on Jul. 27, 2016.

Publication Classification

(51) **Int. Cl.**
F24F 11/00 (2006.01)
G06Q 20/14 (2006.01)
G06Q 20/12 (2006.01)
G05B 19/042 (2006.01)
G06Q 50/06 (2006.01)

(52) **U.S. Cl.**
CPC **F24F 11/0034** (2013.01); **F24F 11/0012**
(2013.01); **F24F 11/006** (2013.01); **G05B**
19/0428 (2013.01); **G06Q 50/06** (2013.01);
G06Q 20/127 (2013.01); **G06Q 20/145**
(2013.01); **F24F 2011/0036** (2013.01); **F24F**
2011/0058 (2013.01); **F24F 2011/0057**
(2013.01); **F24F 2011/0064** (2013.01); **F24F**
2011/0068 (2013.01); **F24F 2011/0075**
(2013.01); **G05B 2219/2614** (2013.01)

(57) **ABSTRACT**
A thermostat for a building space. The thermostat includes a communications interface and a processing circuit. The communications interface is configured to engage in bidirectional communications with heating, ventilation, or air conditioning (HVAC) equipment and to receive an indication of a current heating or cooling load from the HVAC equipment. The processing circuit is configured to determine an occupancy of the building space based on the indication of the current heating or cooling load received from the HVAC equipment. The processing circuit is further configured to operate the HVAC equipment based on the determined occupancy of the building space.

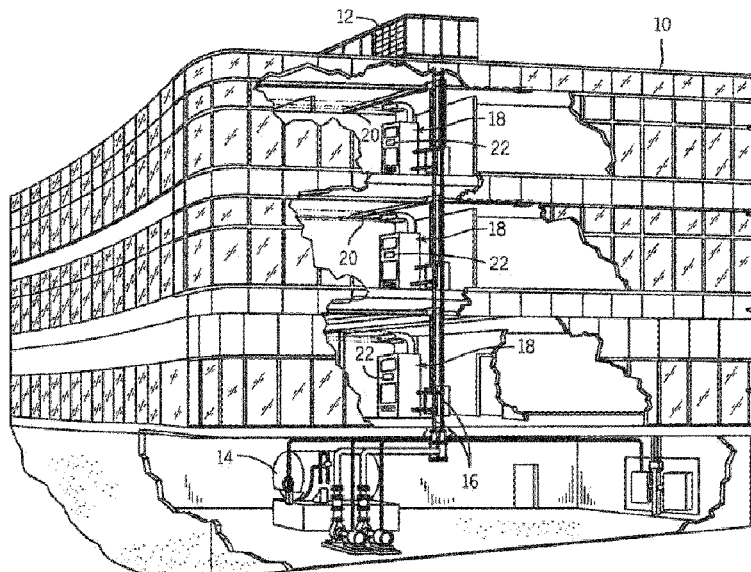

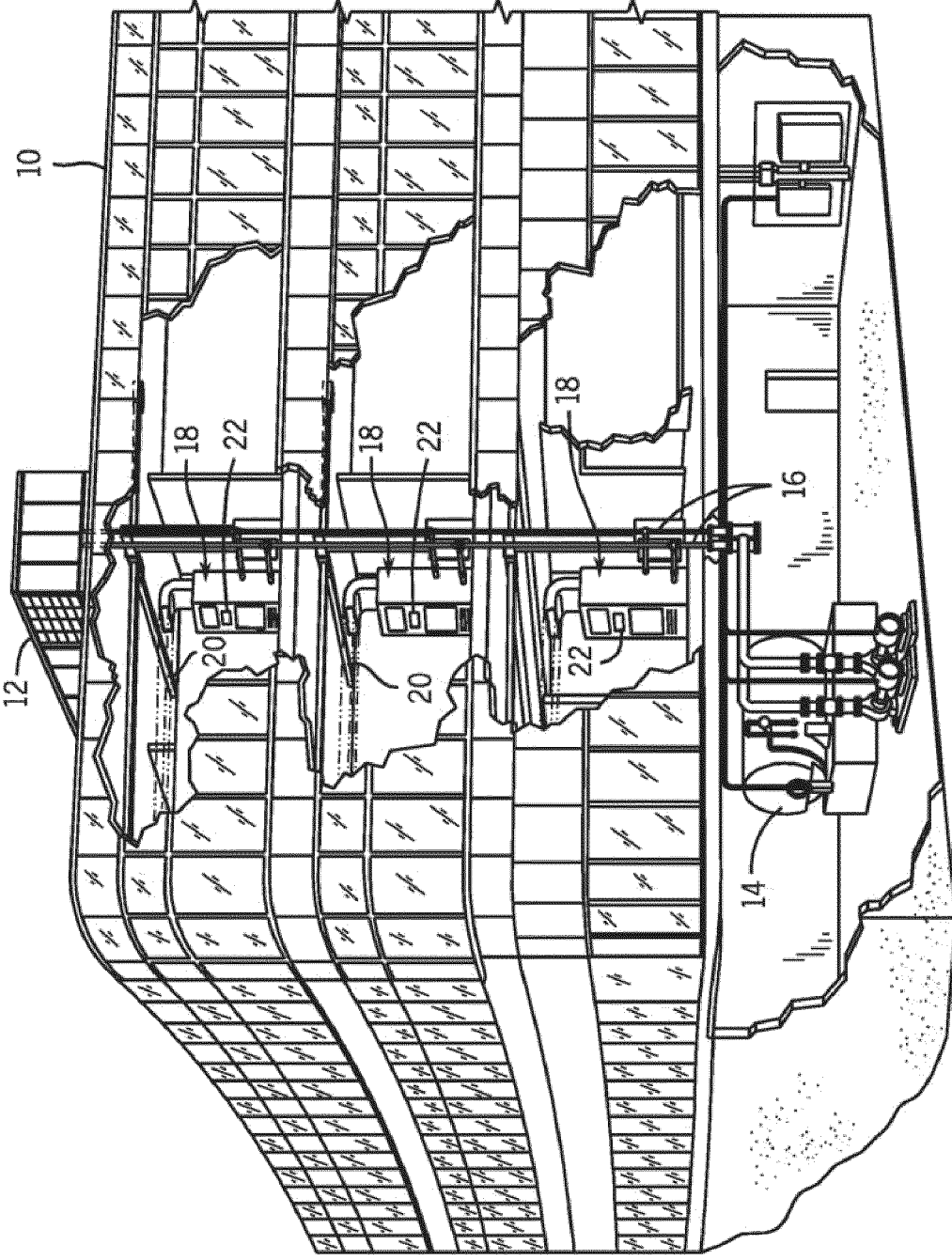

FIG. 1

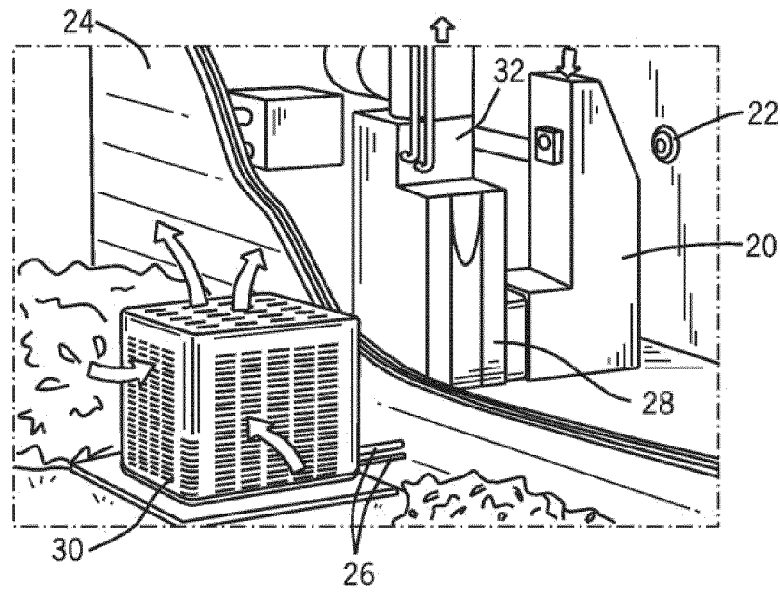

FIG. 2

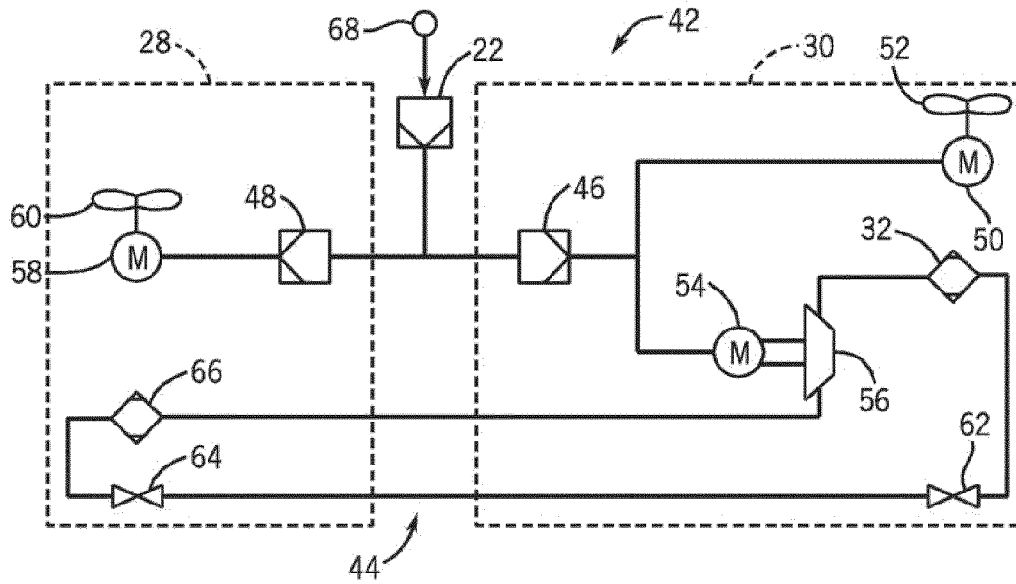

FIG. 3

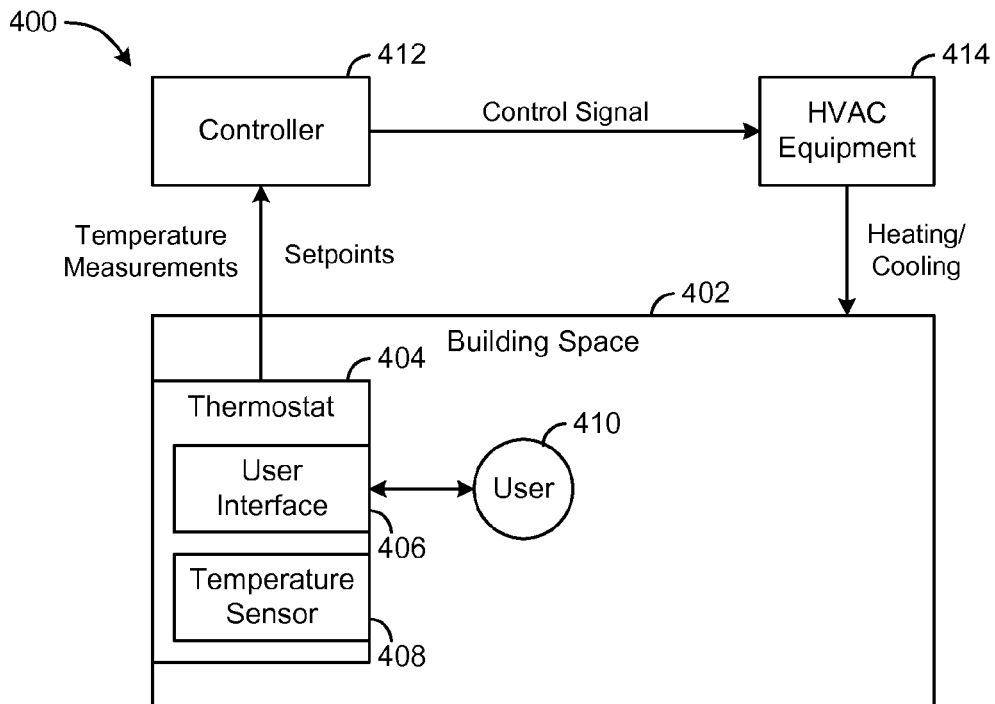

FIG. 4

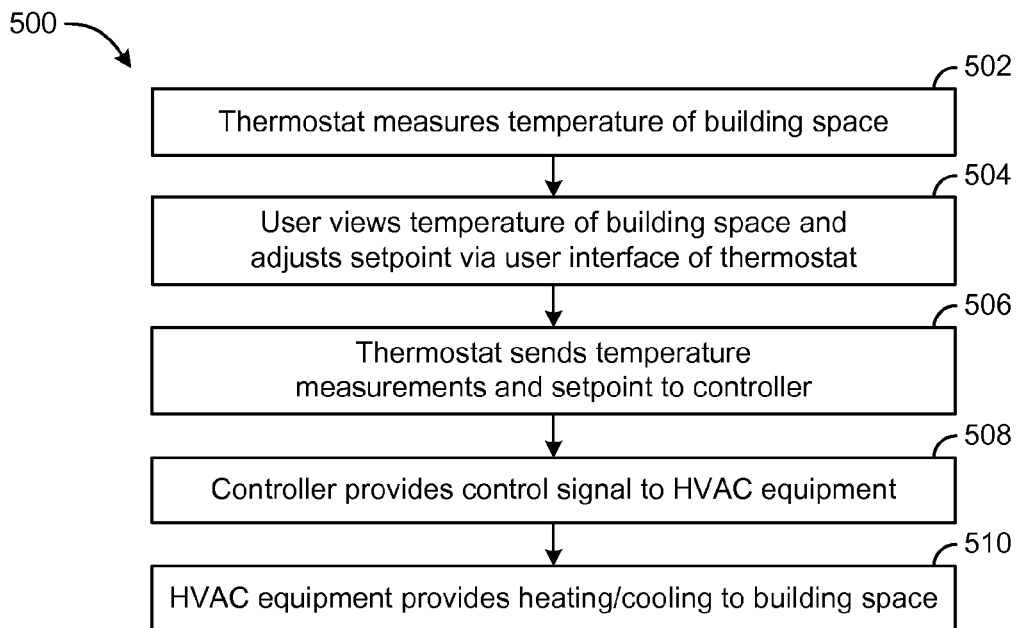

FIG. 5

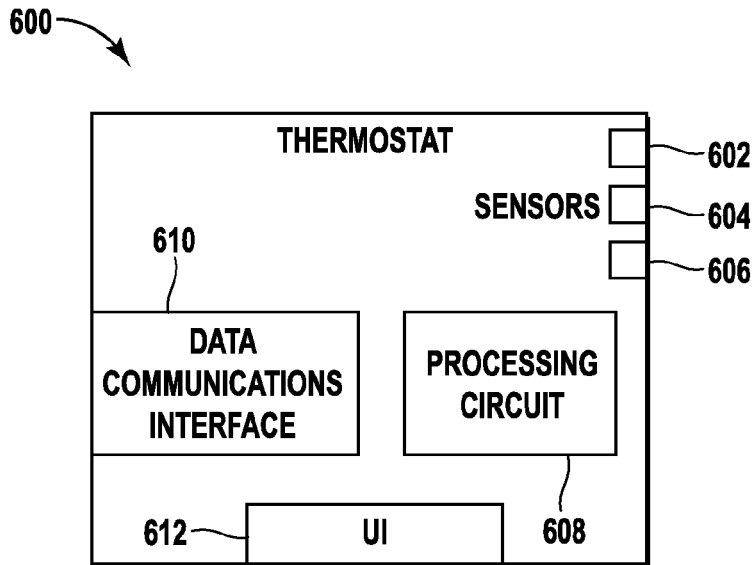

FIG. 6

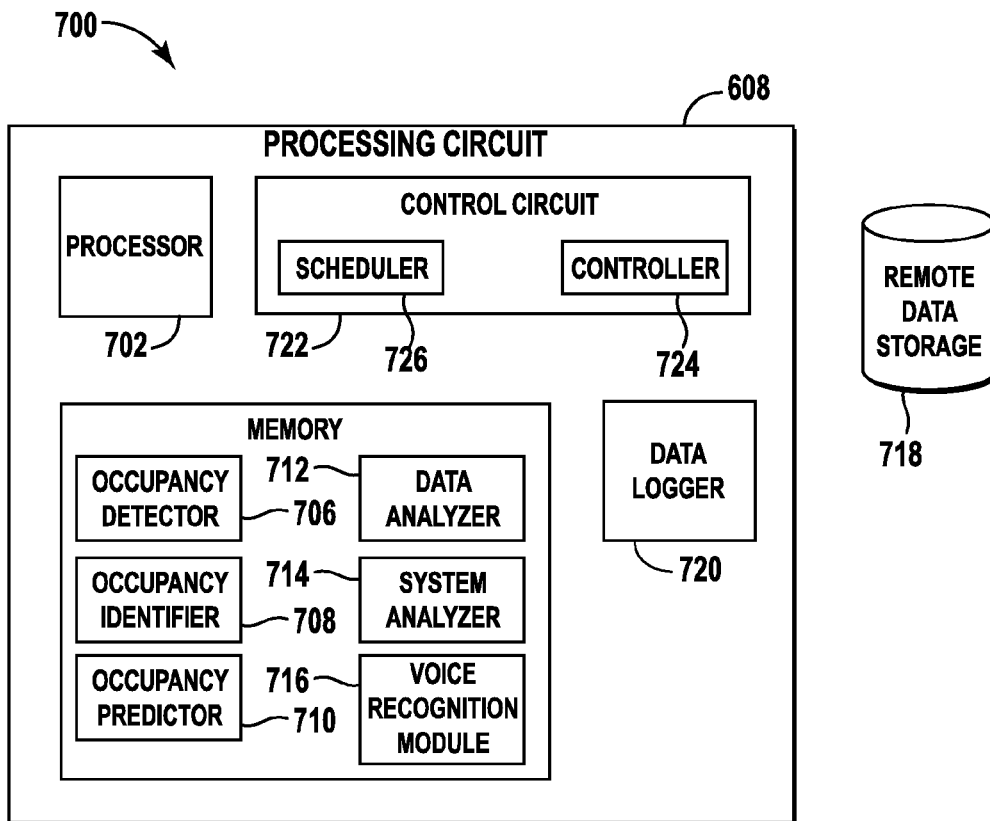

FIG. 7

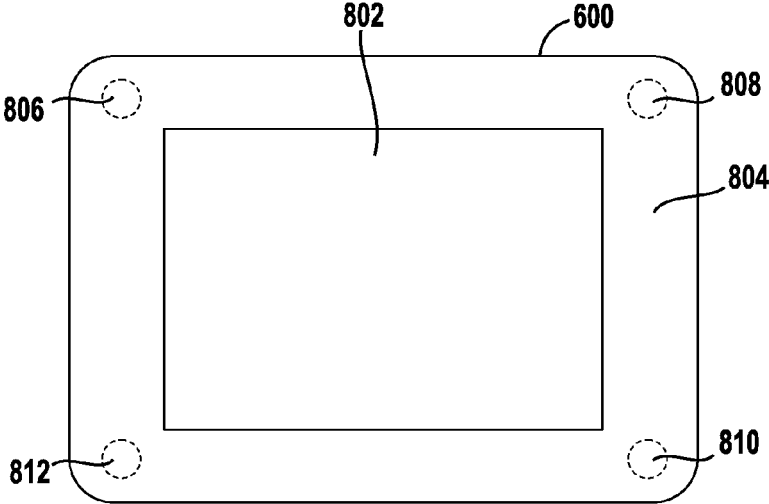

FIG. 8

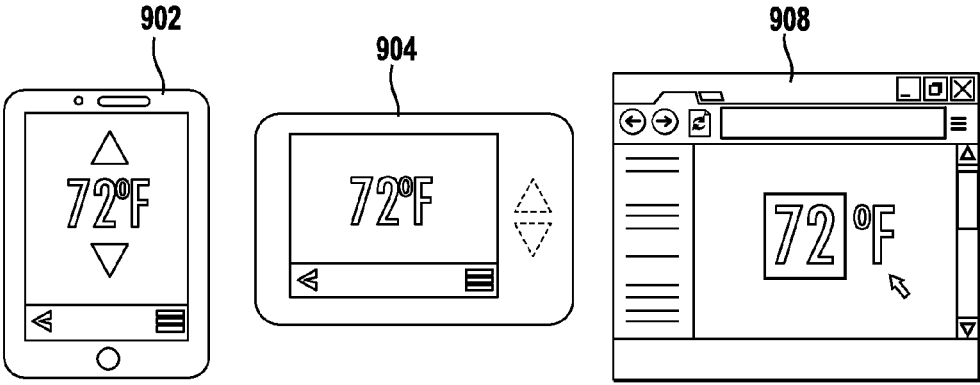

FIG. 9

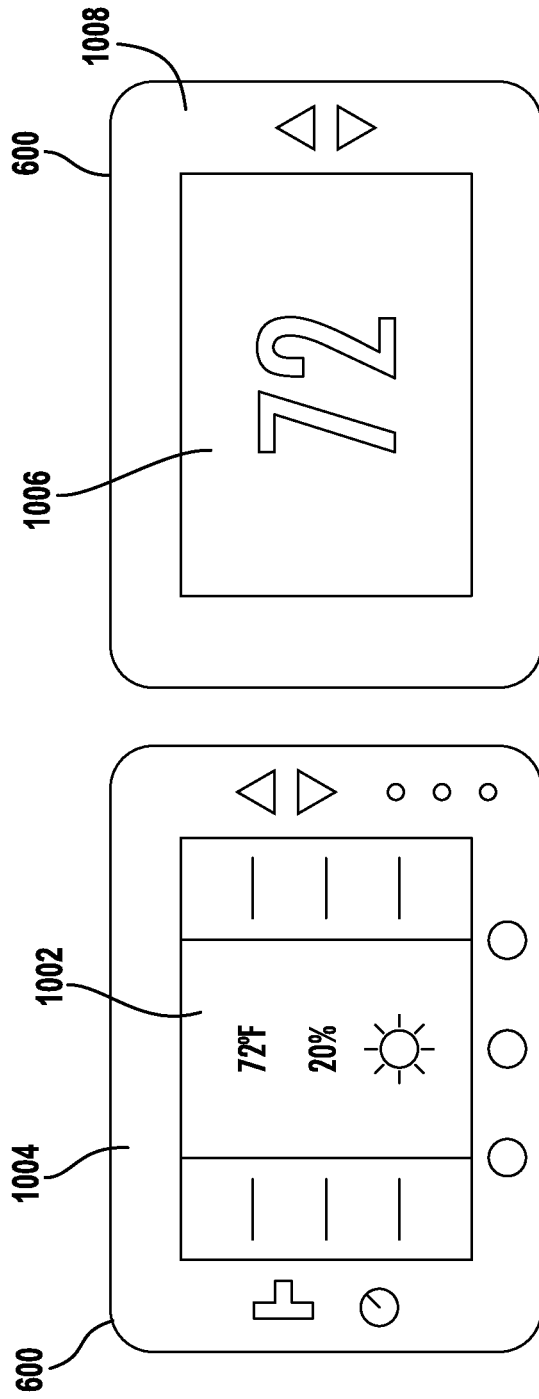

FIG. 10A

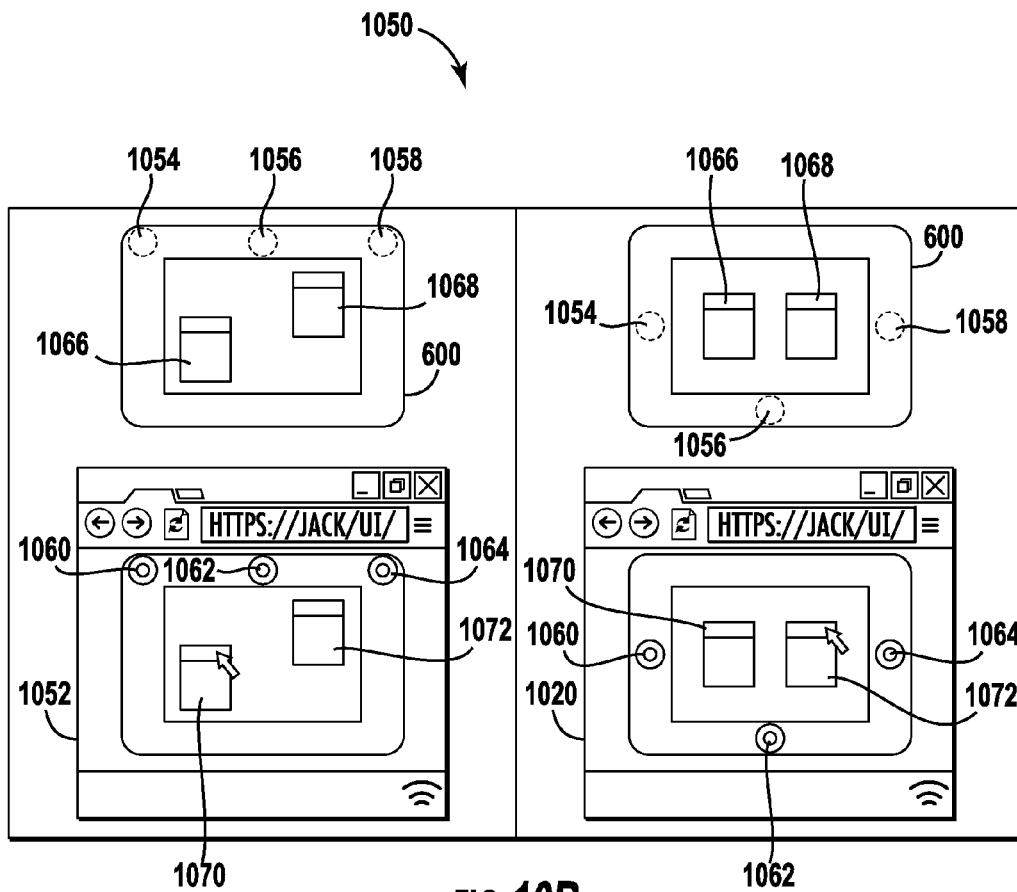

FIG. 10B

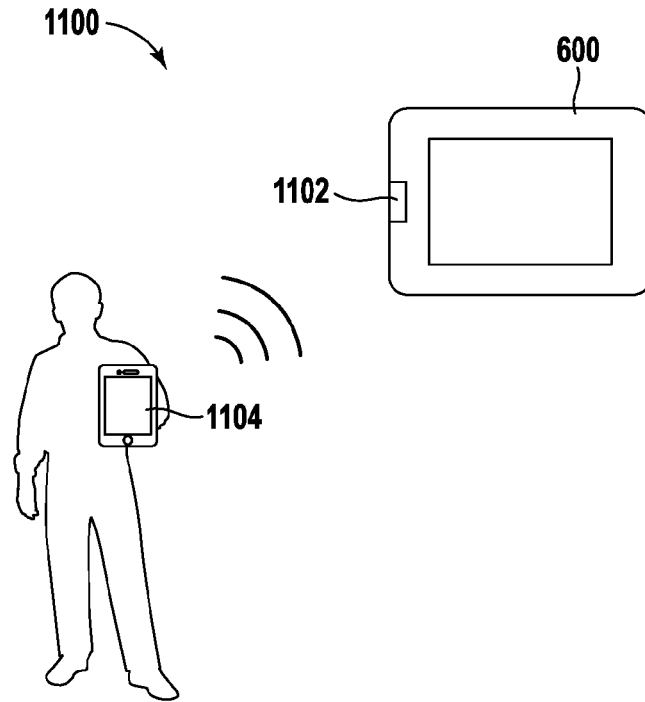

FIG. 11A

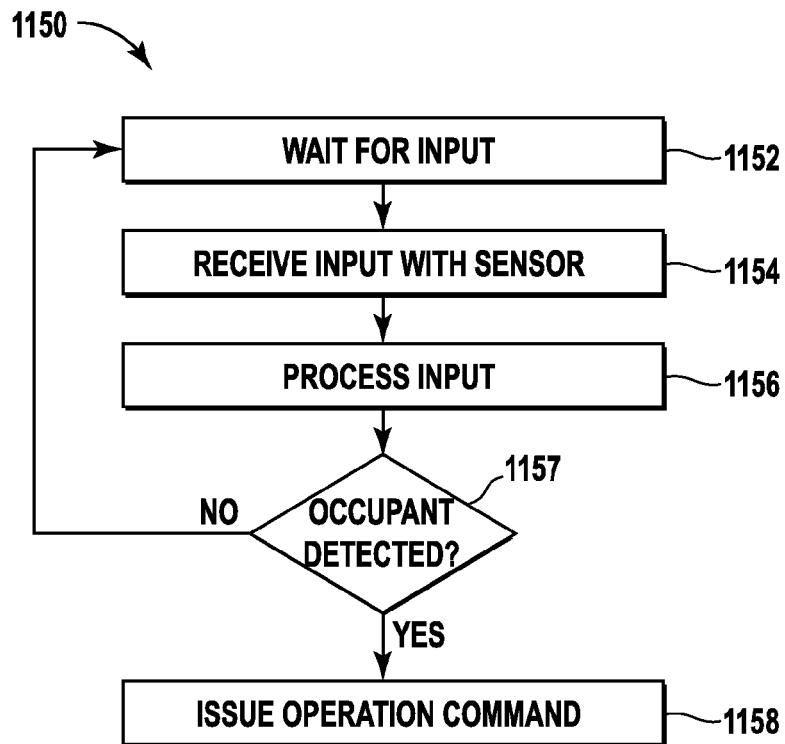

FIG. 11B

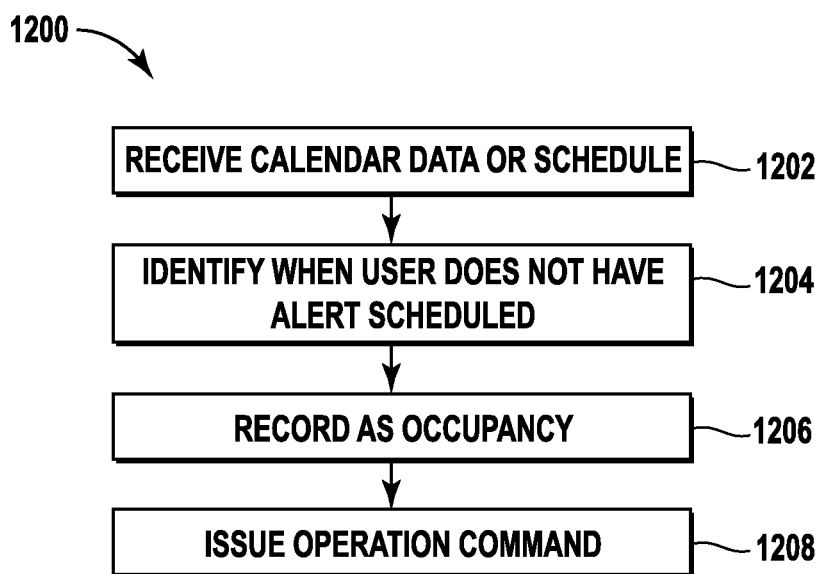

FIG. 12A

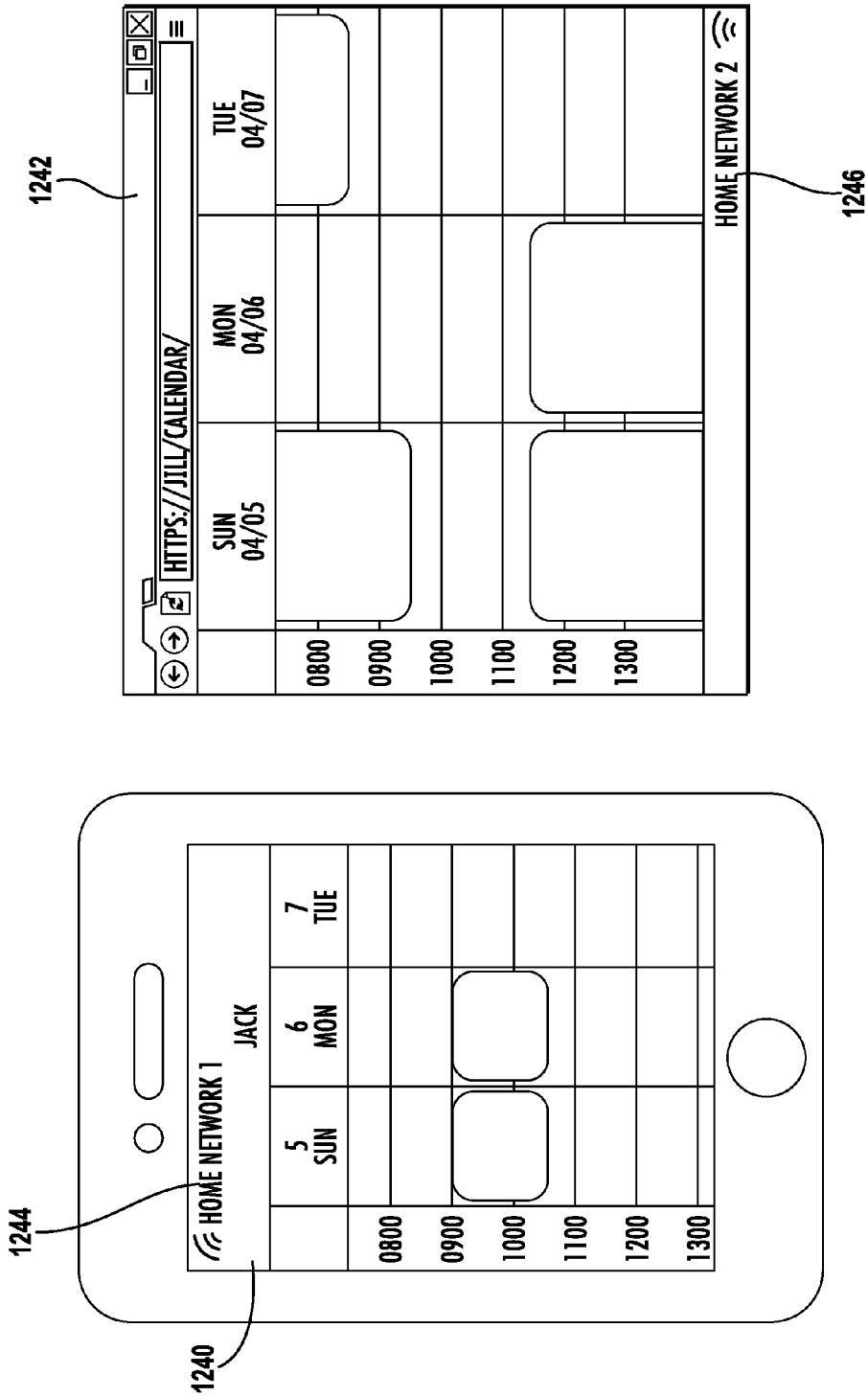

FIG. 12B

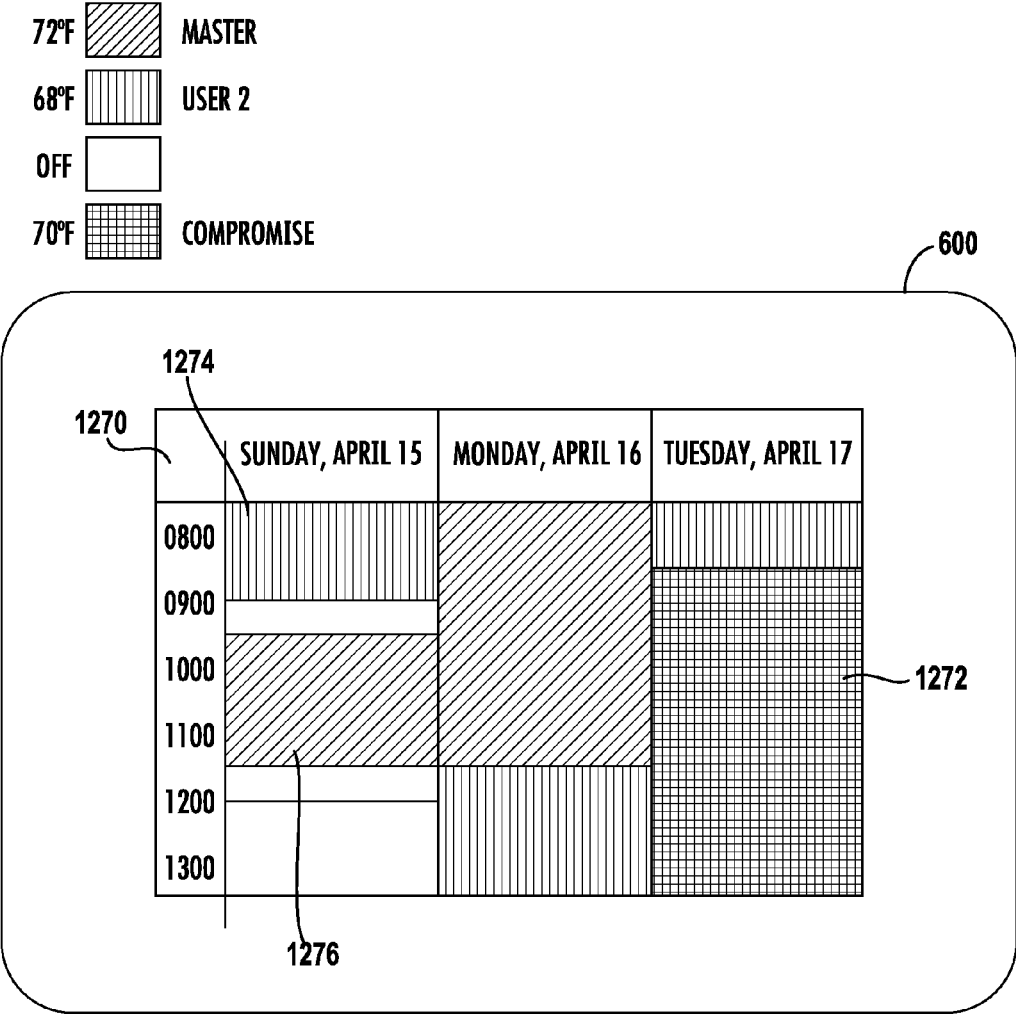

FIG. 12C

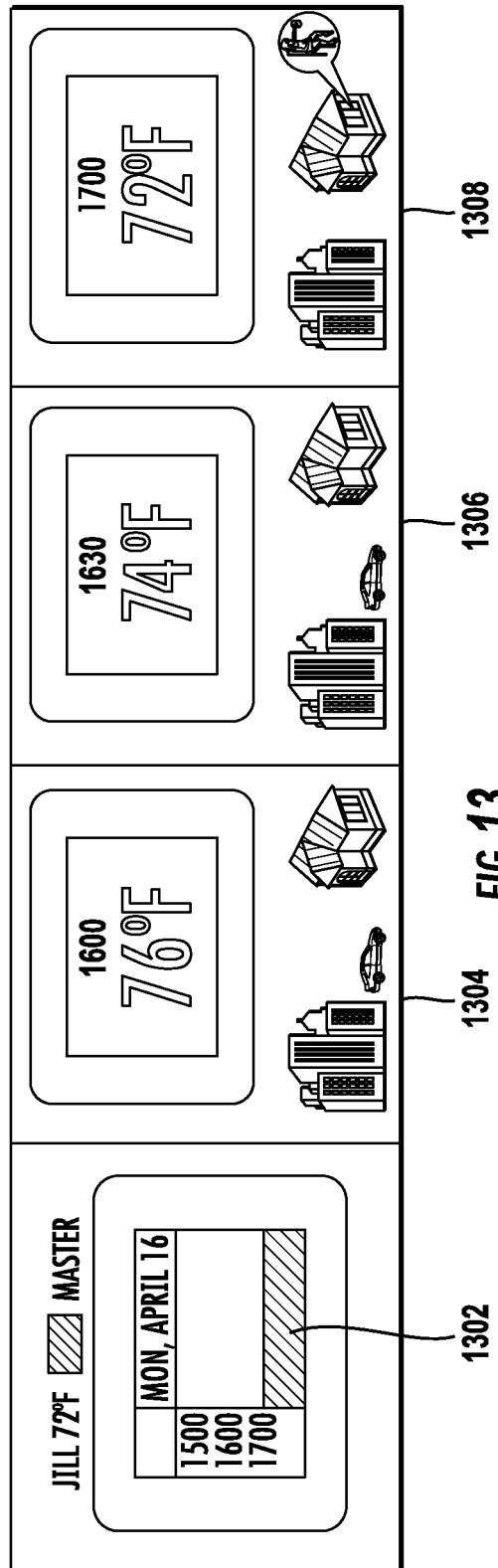

FIG. 13

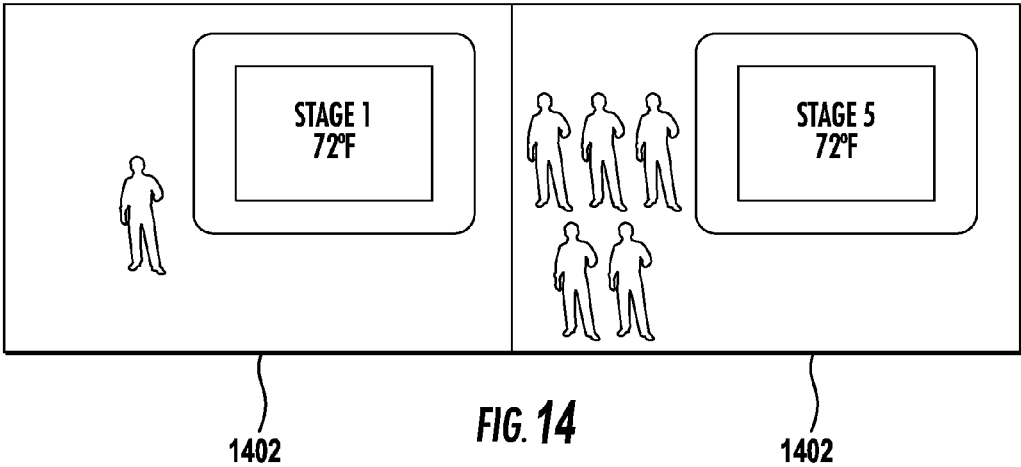

FIG. 14

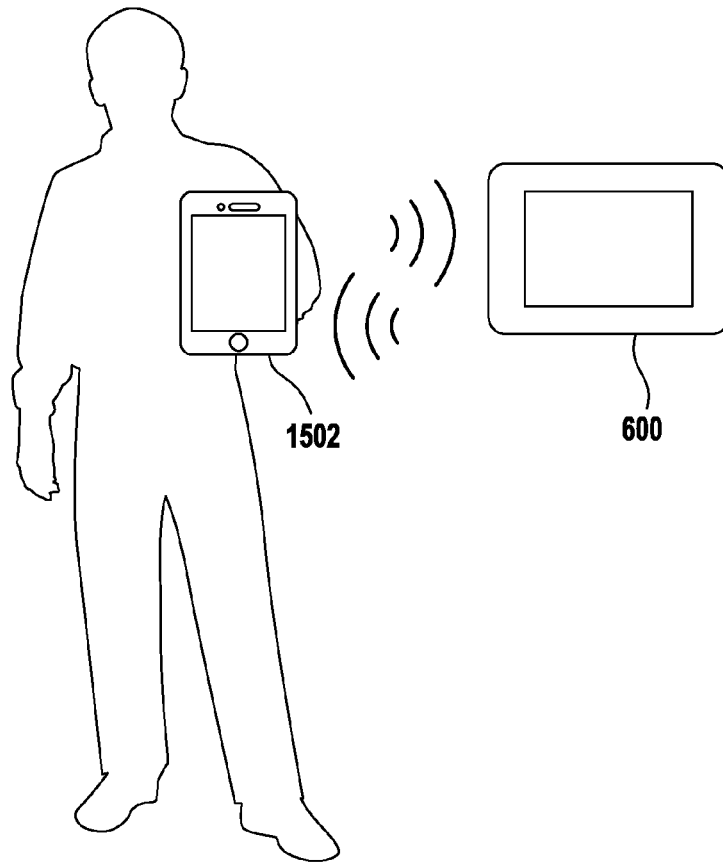

FIG. 15A

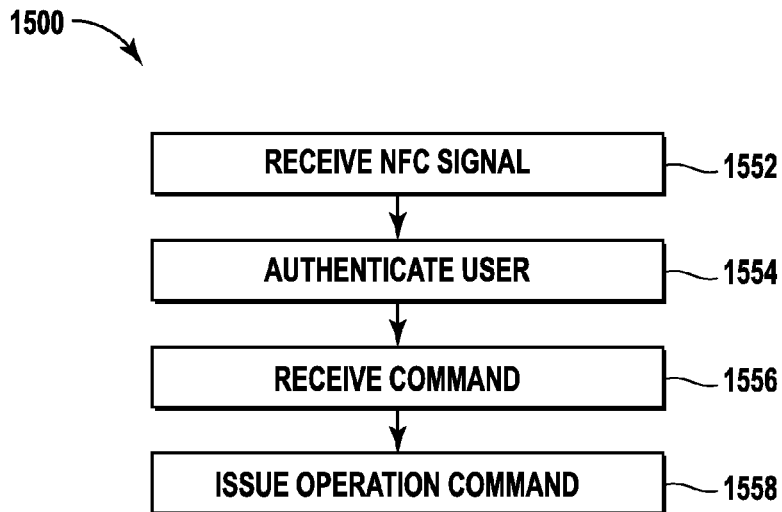

FIG. 15B

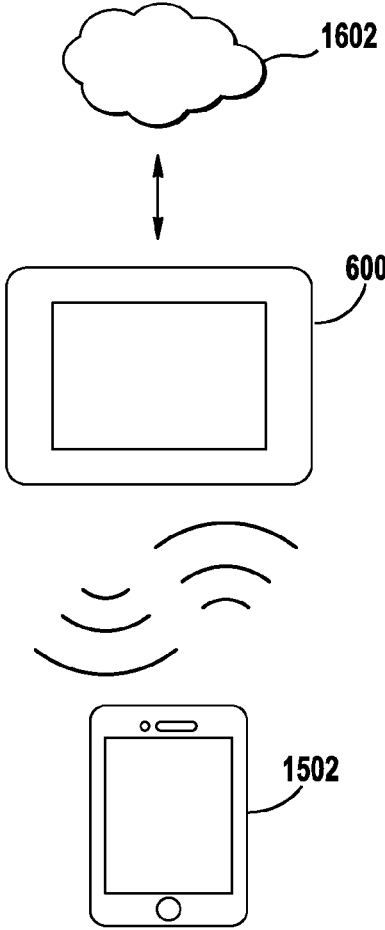

FIG. 16A

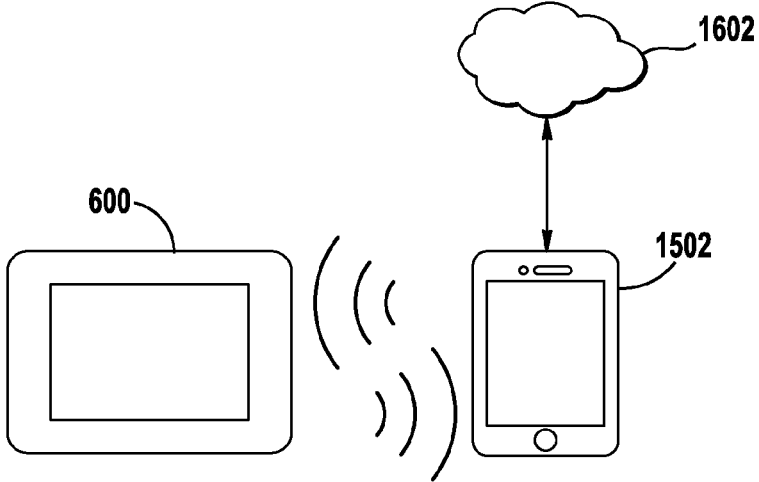

FIG. 16B

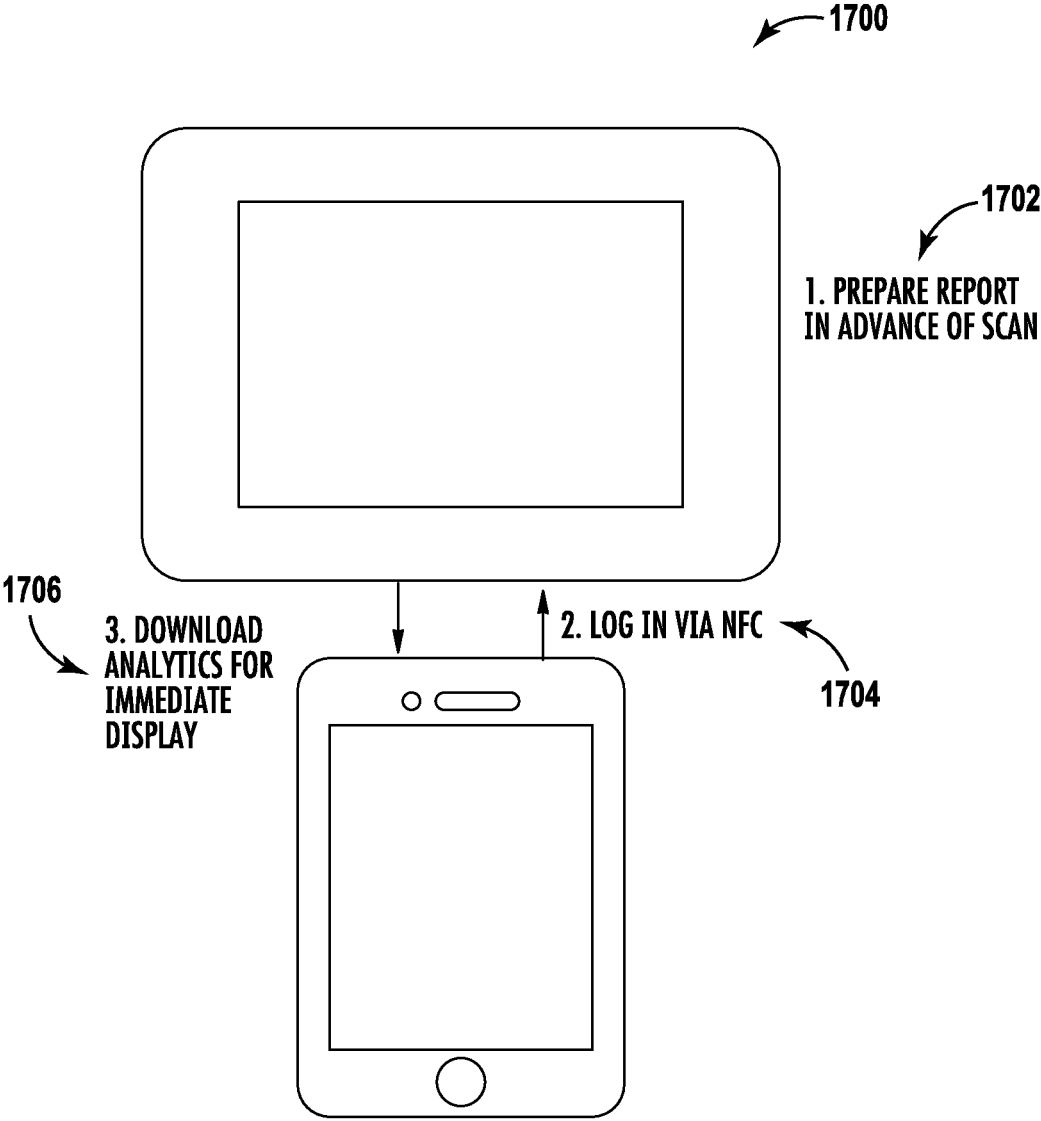

FIG. 17

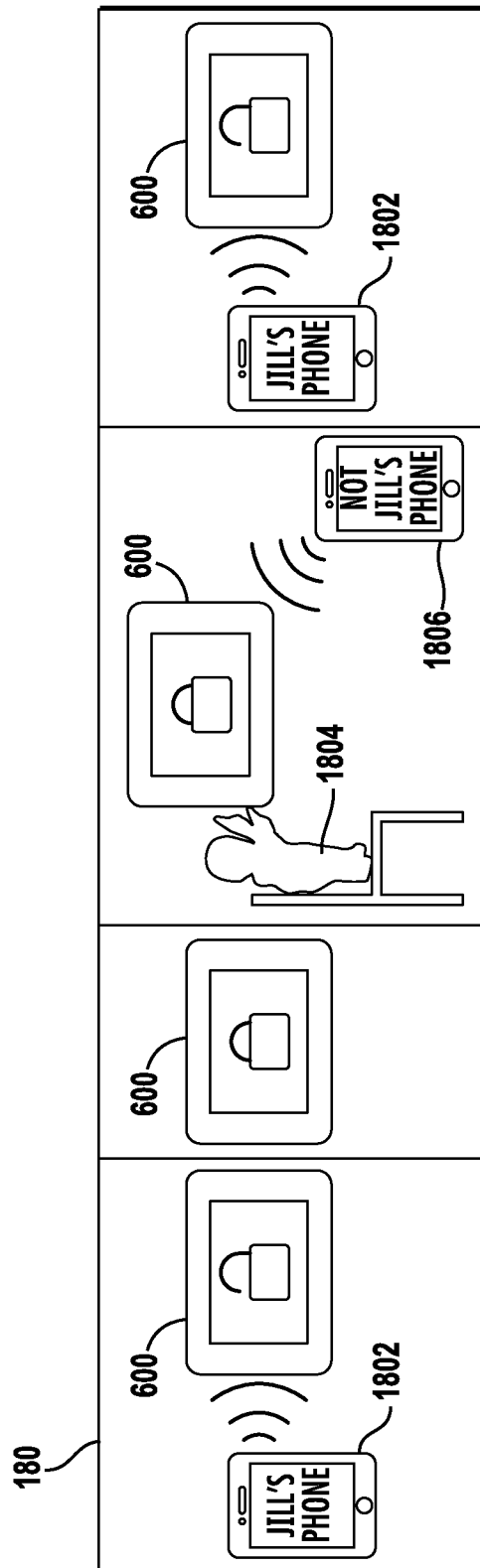

FIG. 18

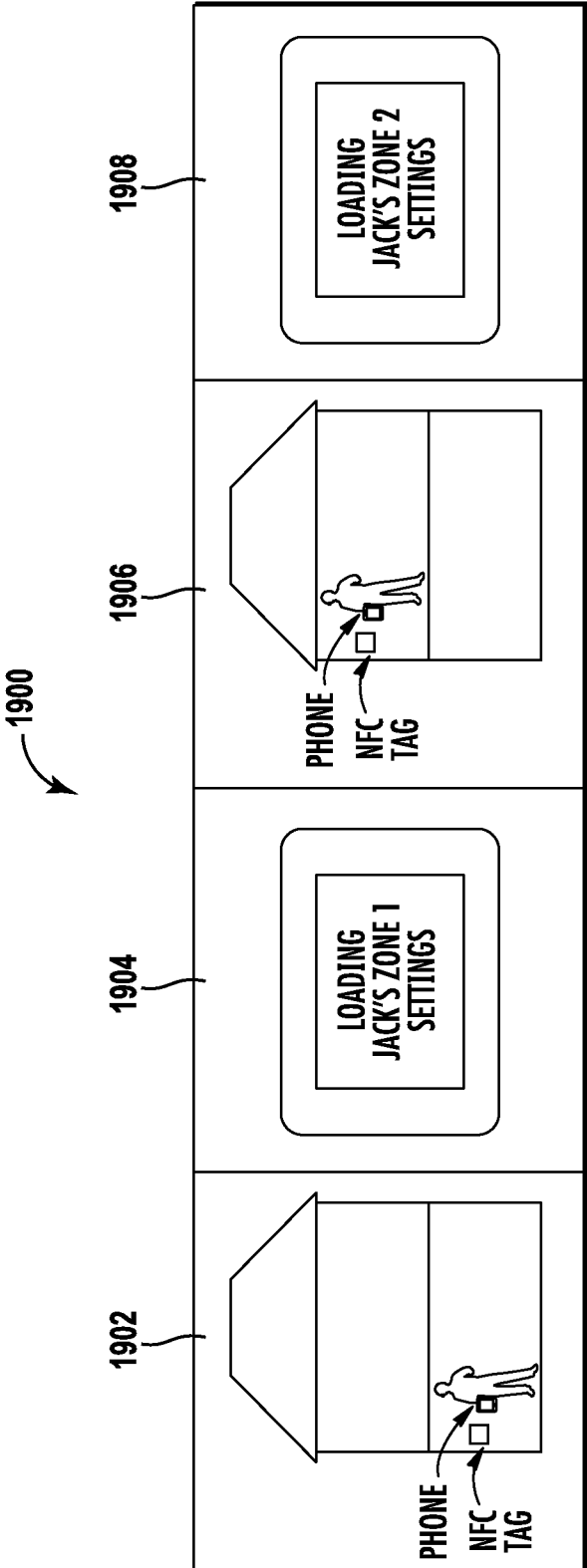

FIG. 19

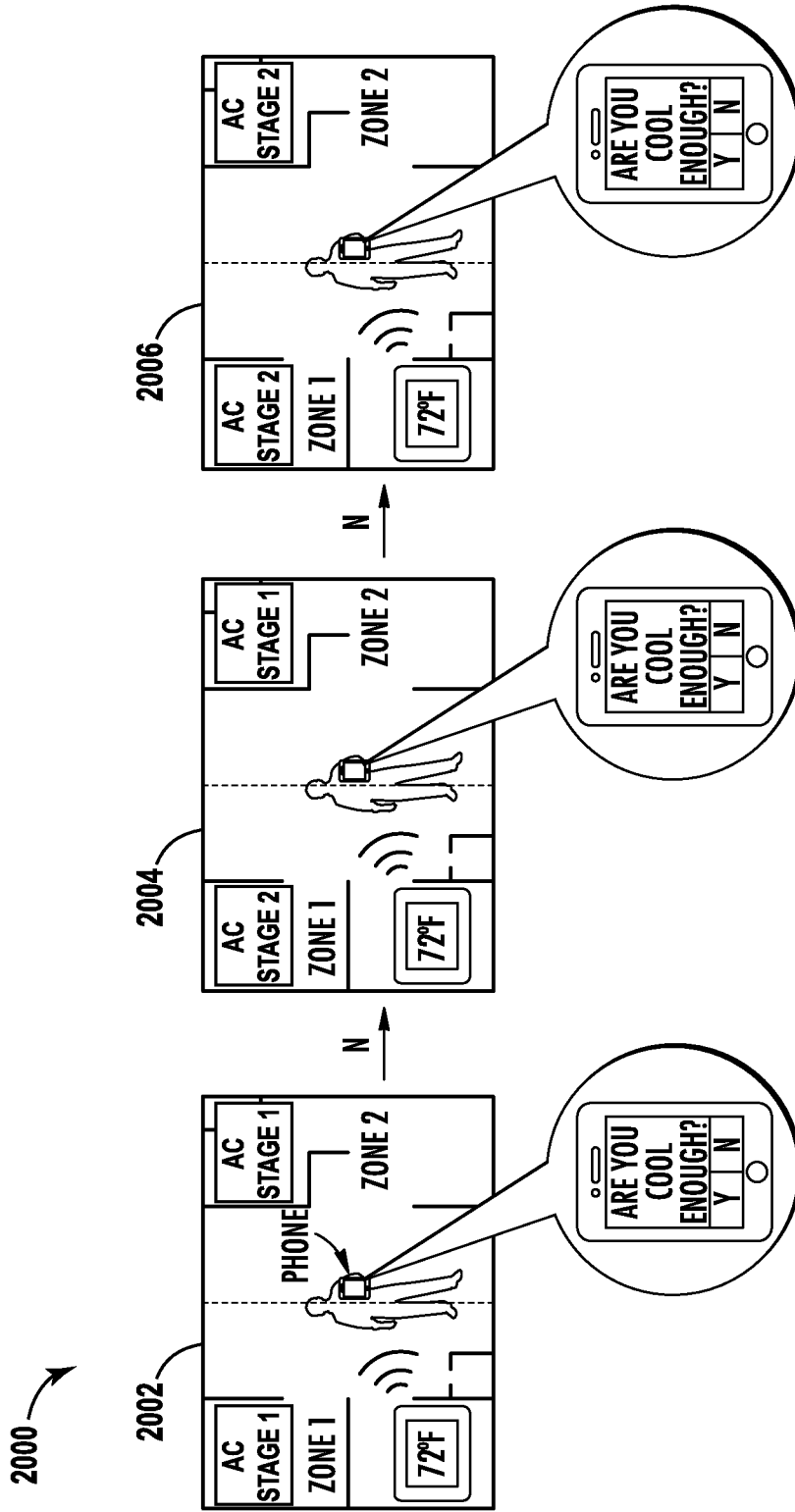

FIG. 20

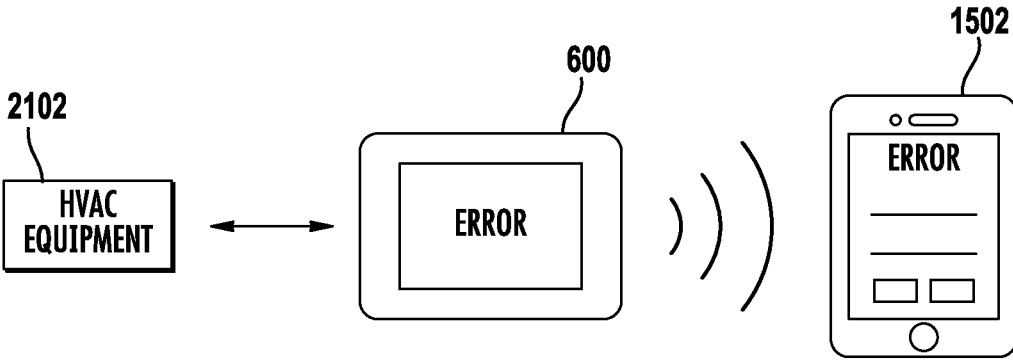

FIG. 21

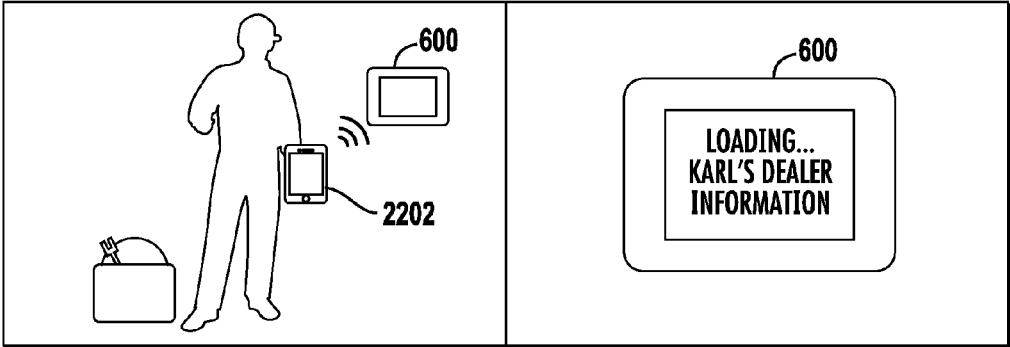

FIG. 22A

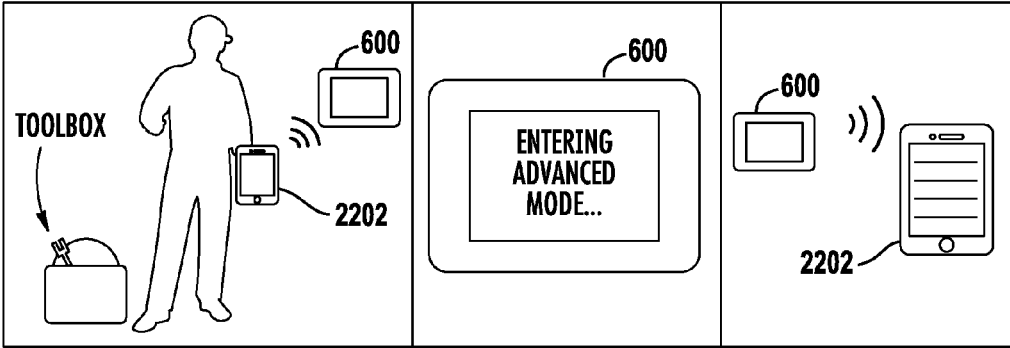

FIG. 22B

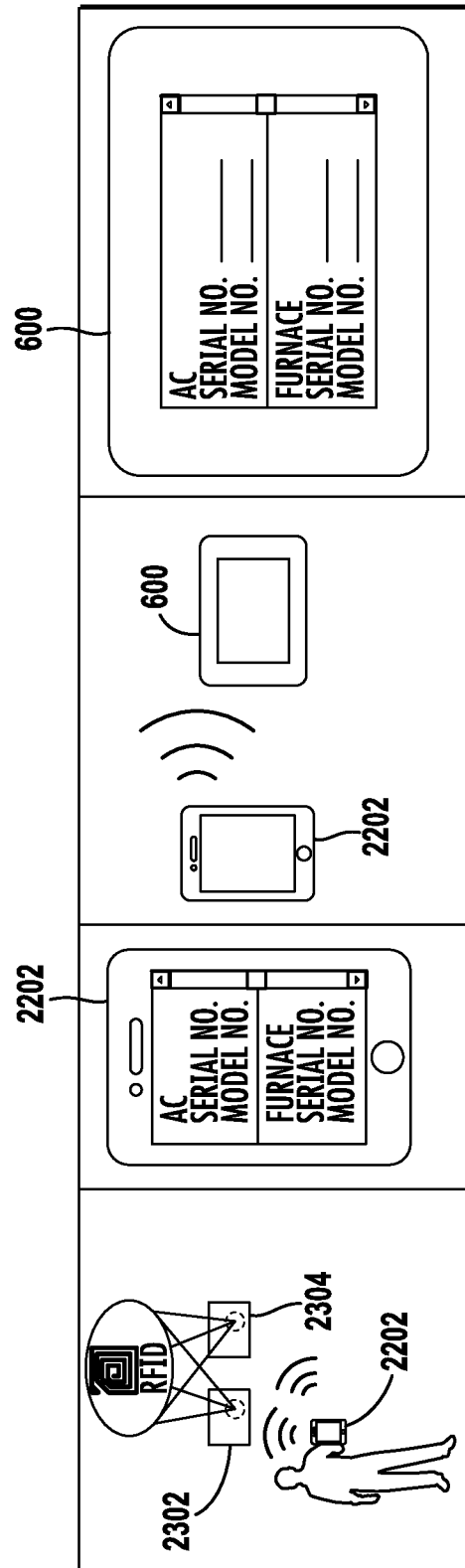

FIG. 23

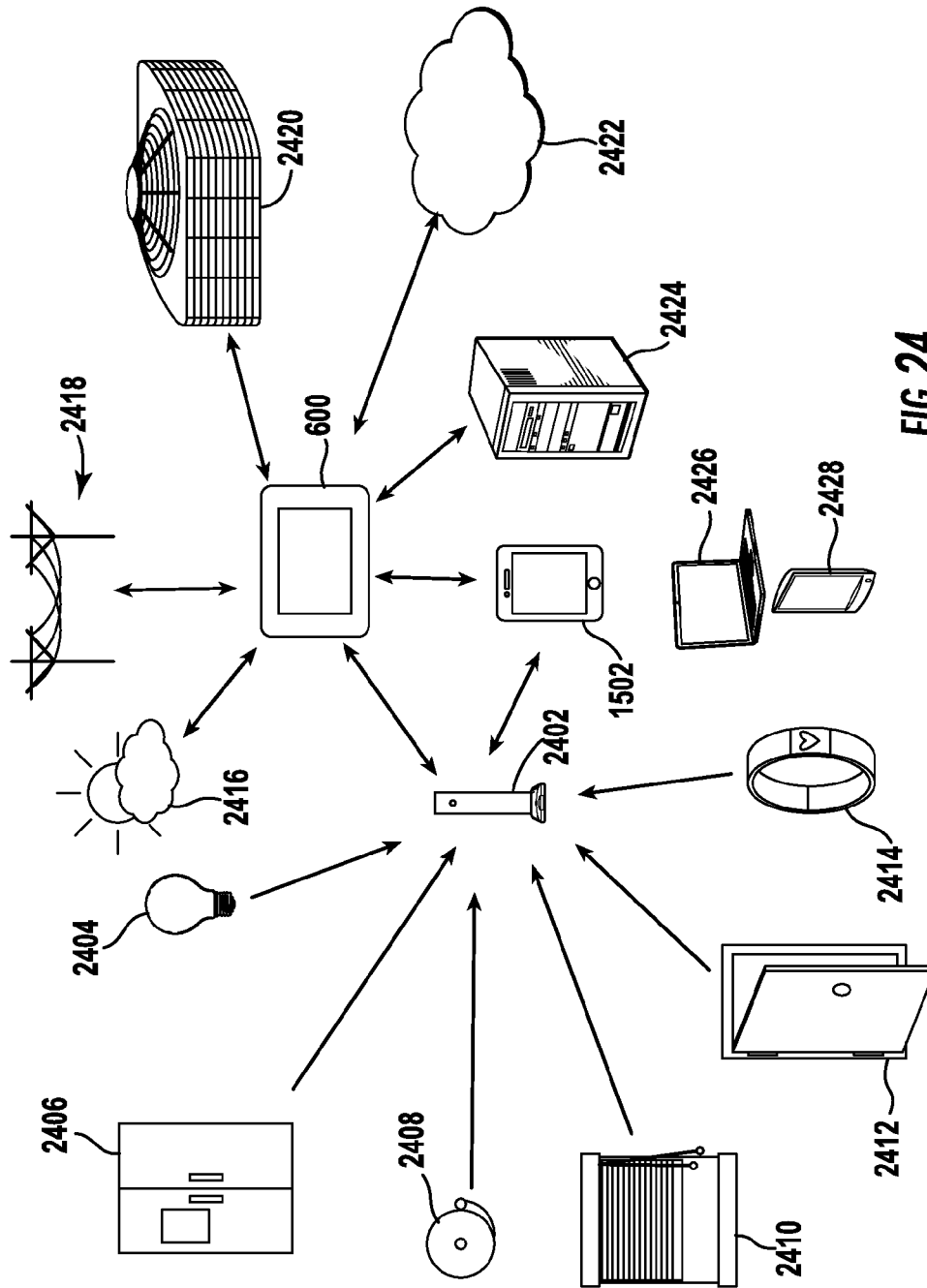

FIG. 24

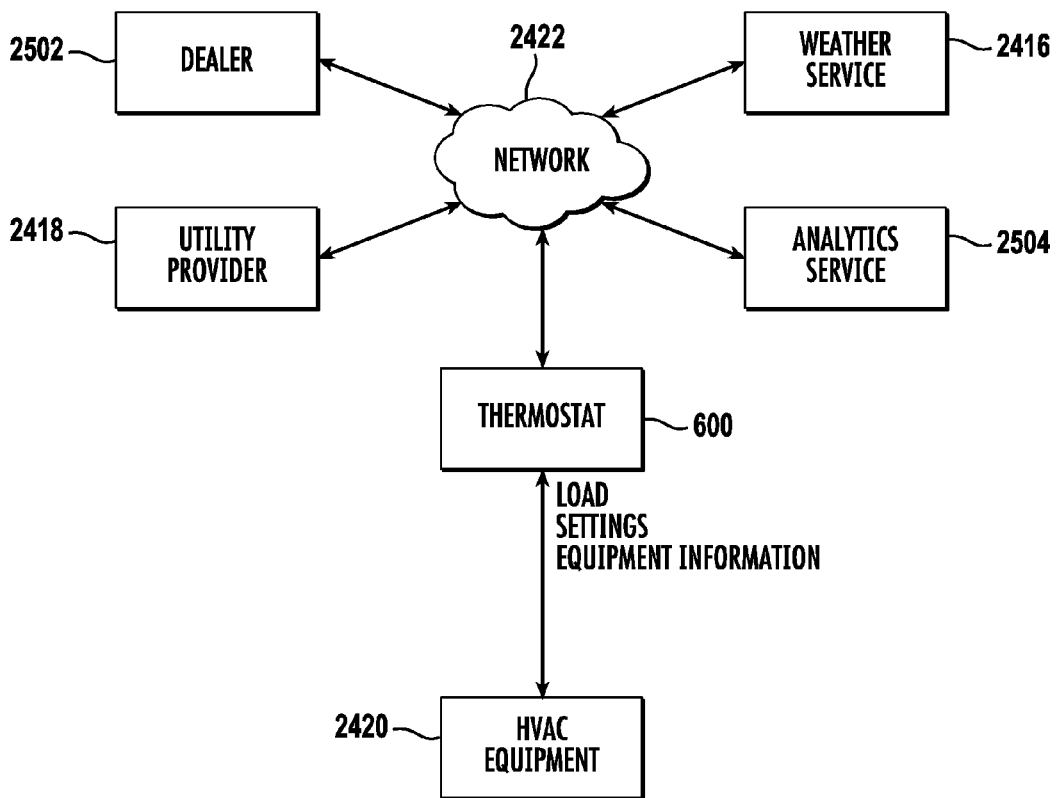

FIG. 25

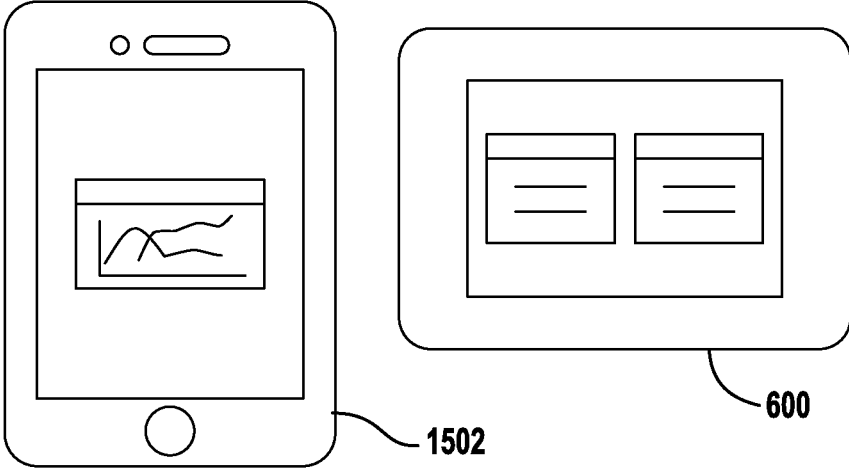

FIG. 26A

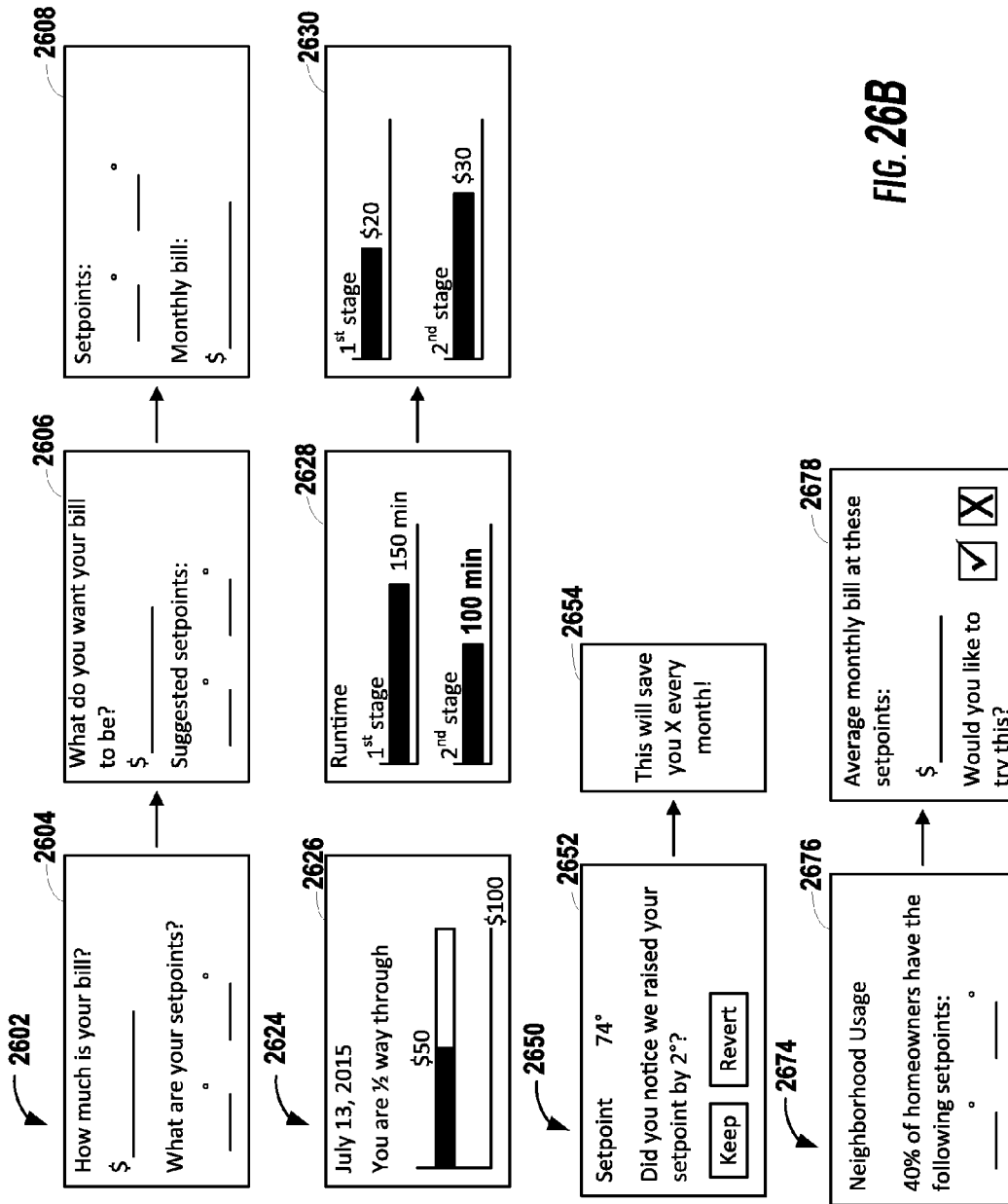

FIG. 26B

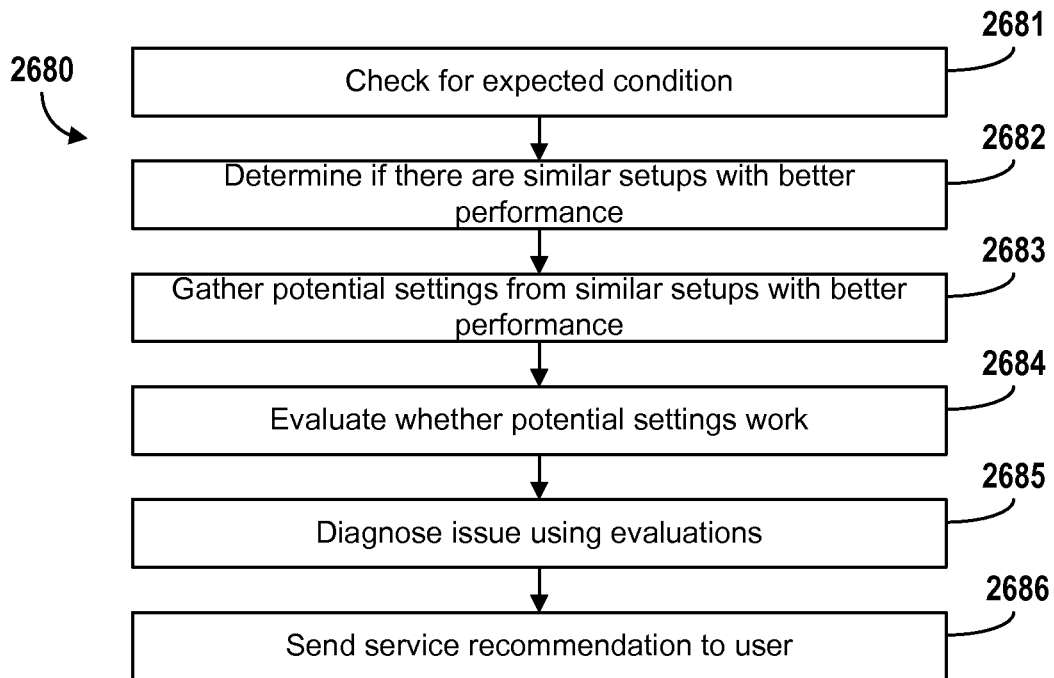

FIG. 26C

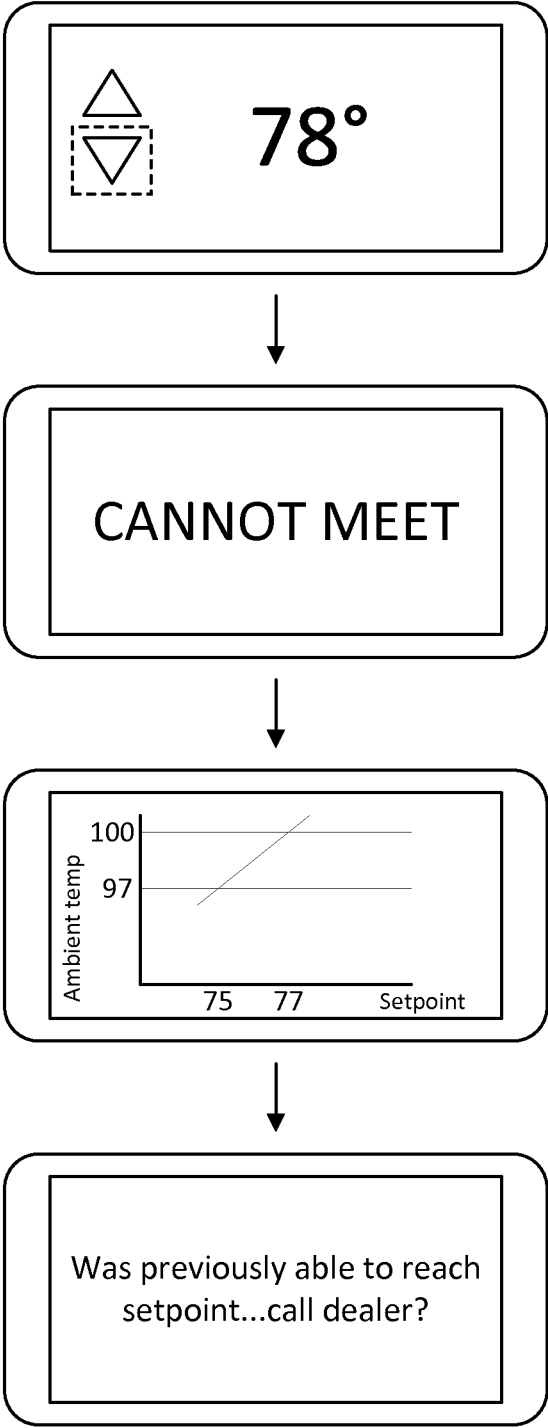

FIG. 26D

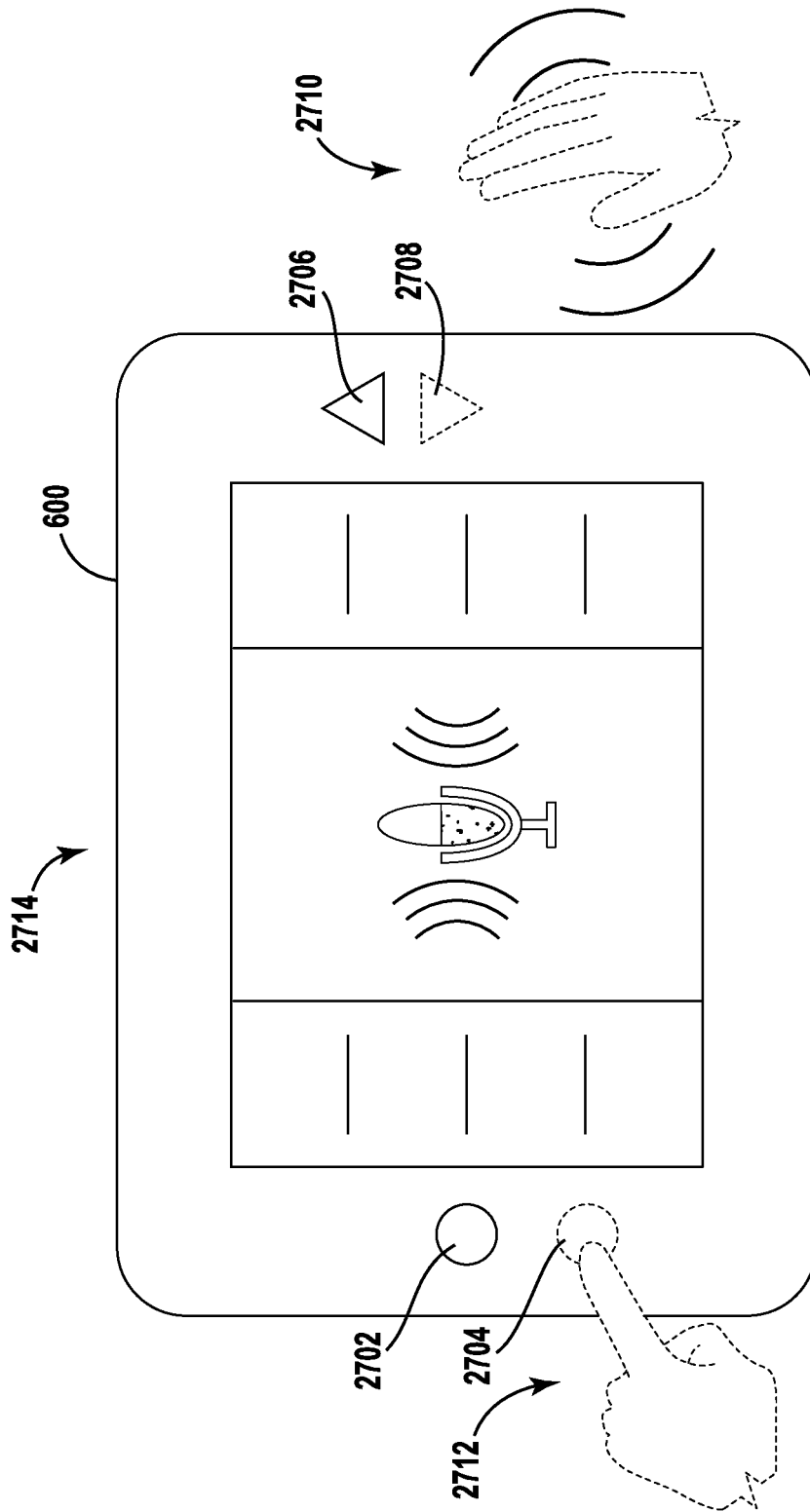

FIG. 27

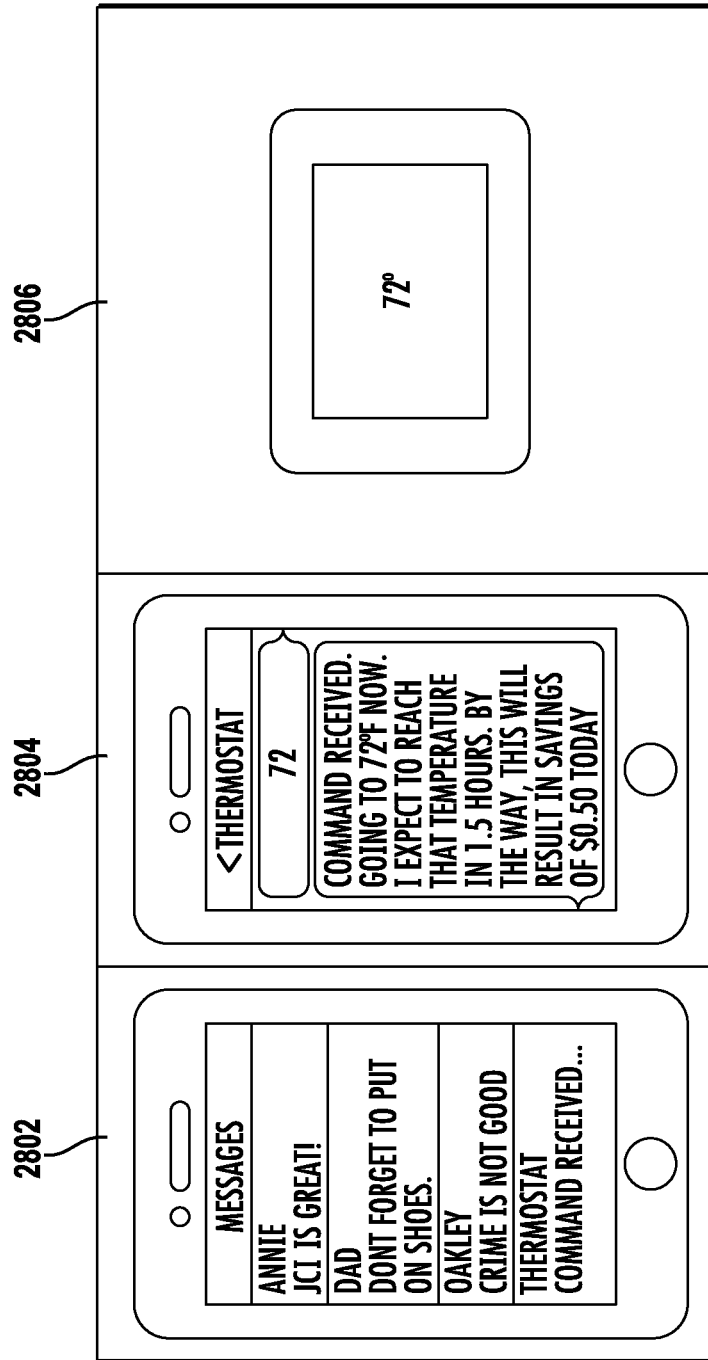

FIG. 28

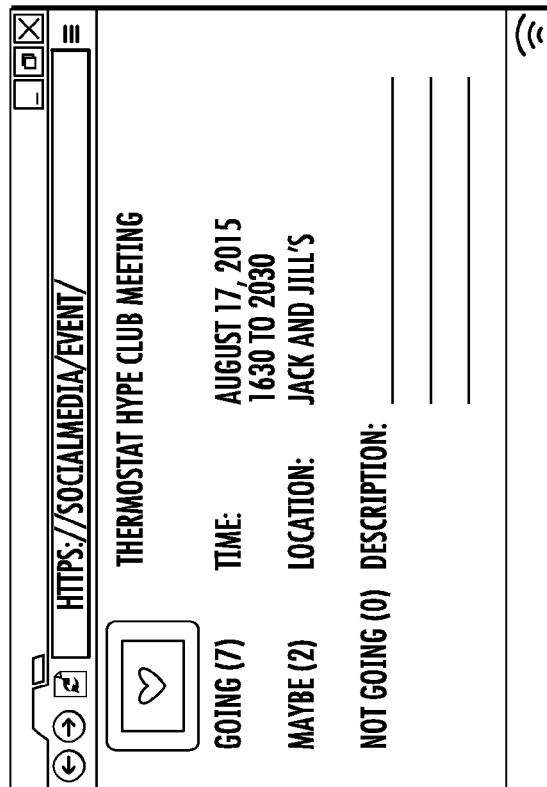
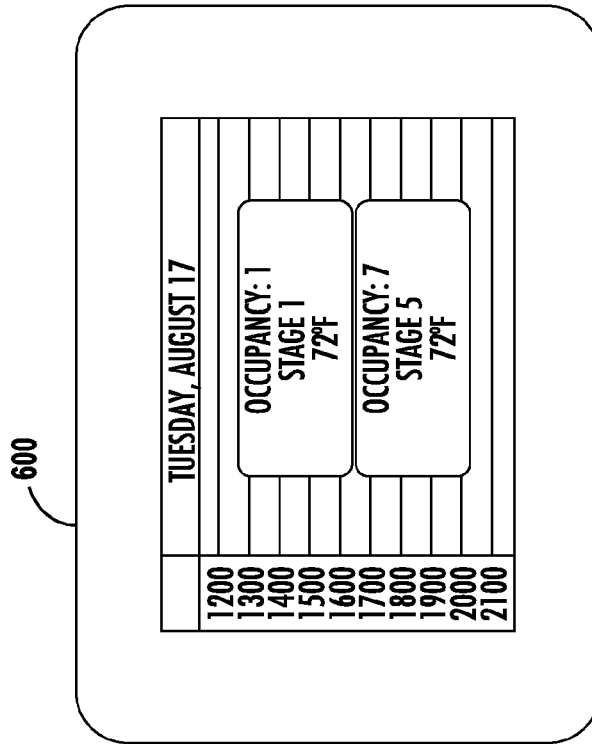

FIG. 29

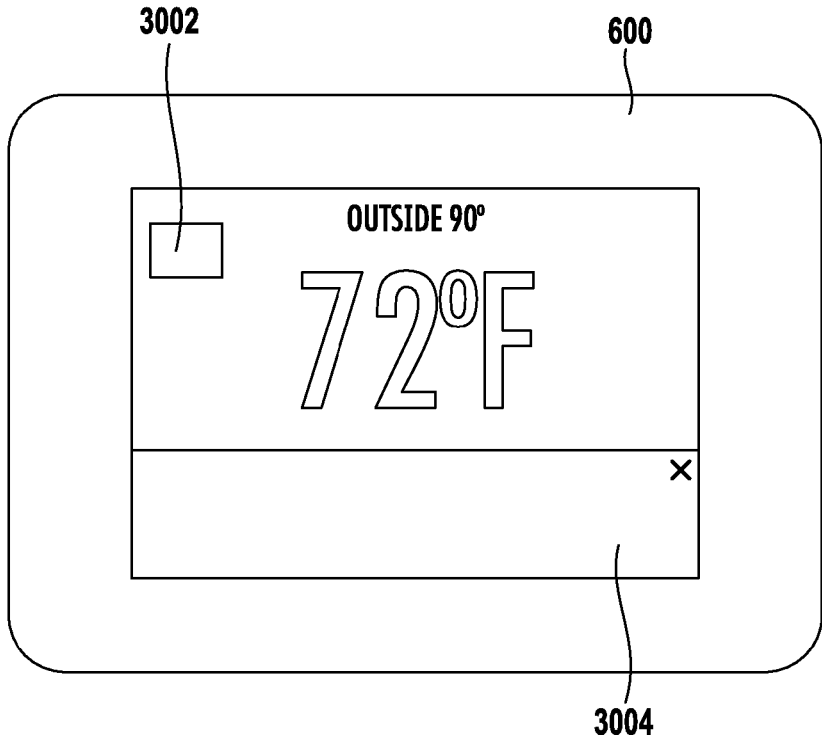

FIG. 30

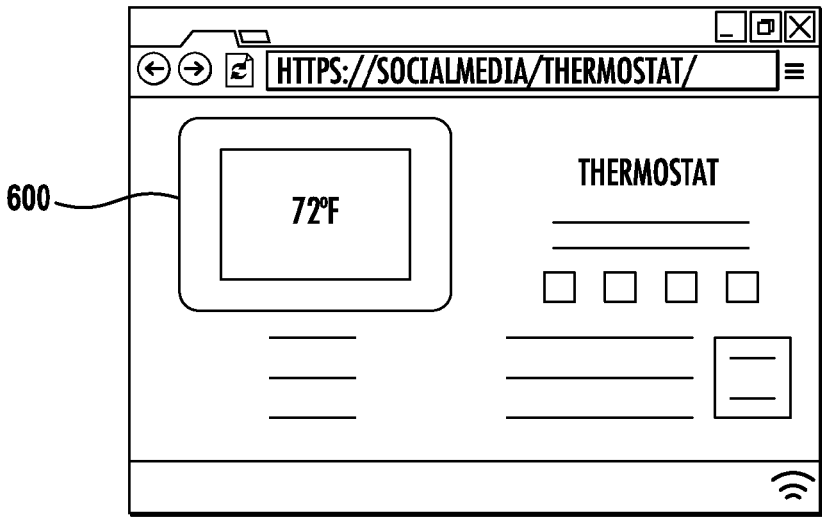

FIG. 31

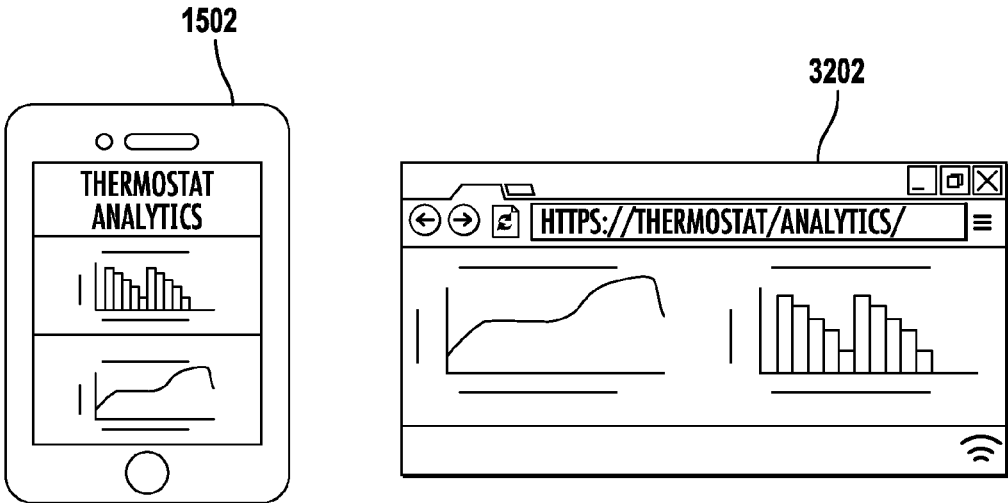

FIG. 32

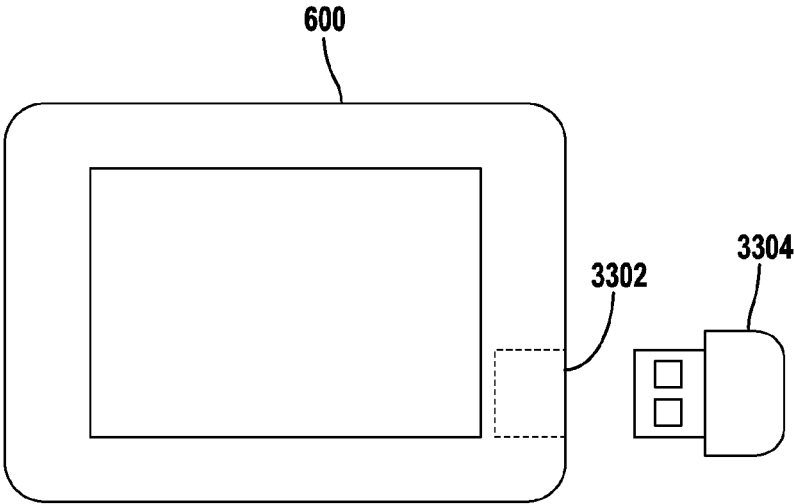

FIG. 33

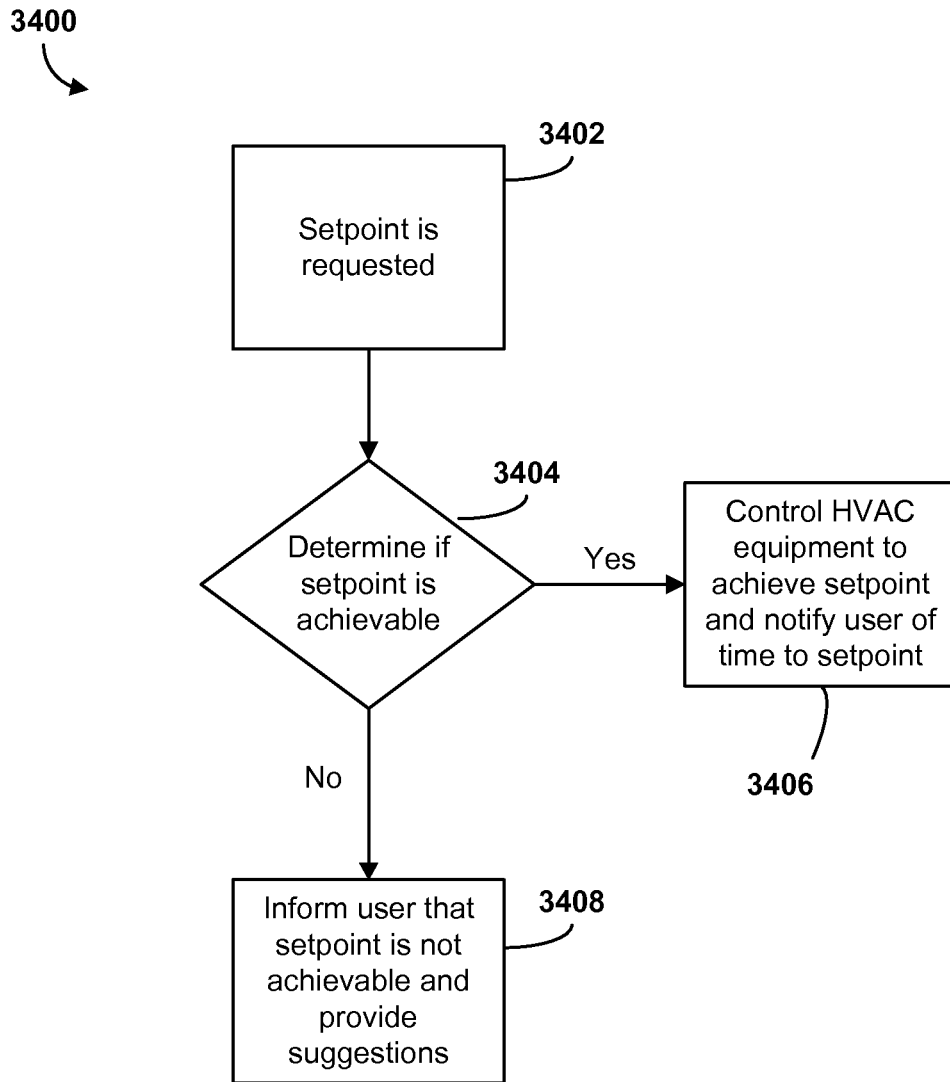

FIG. 34

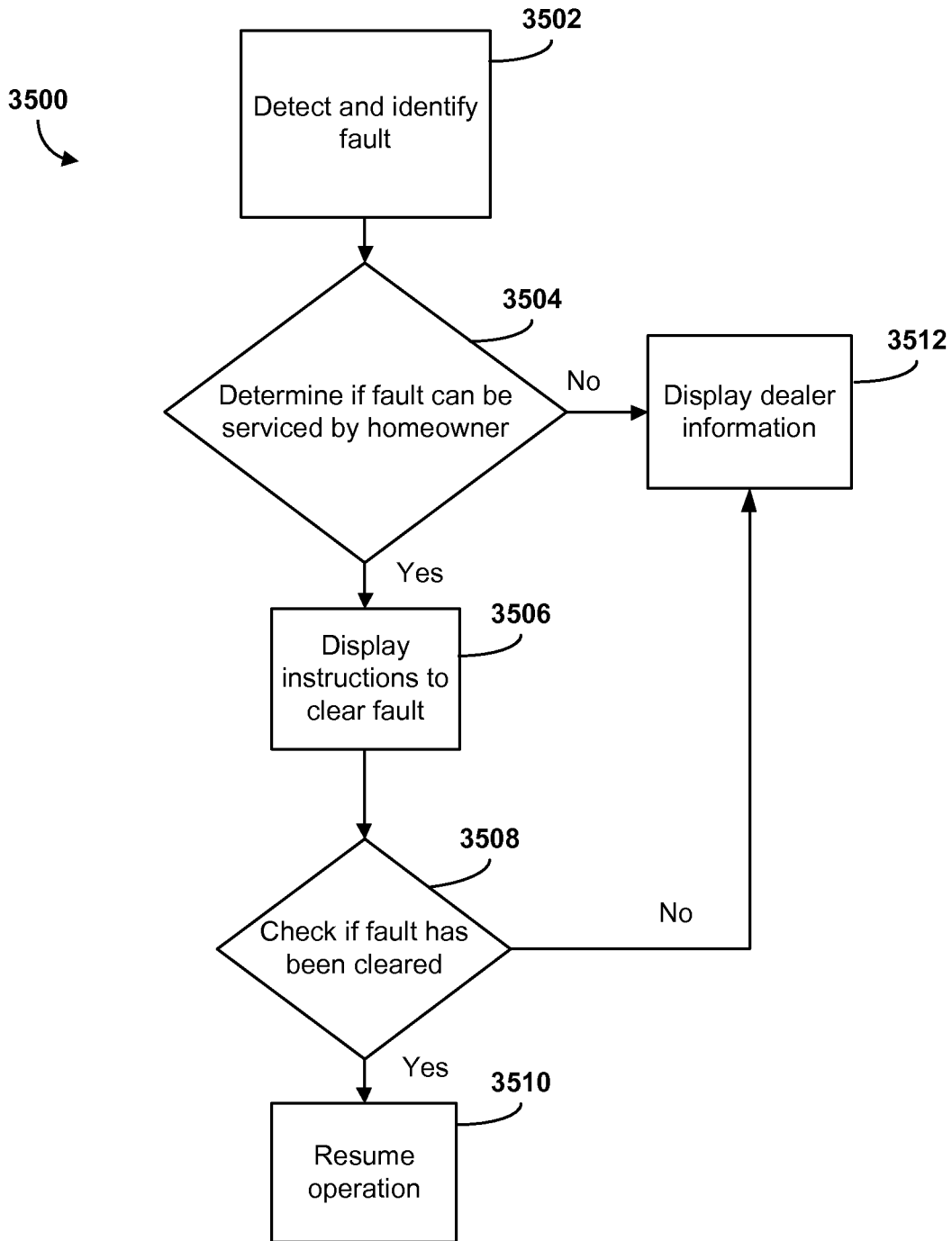

FIG. 35

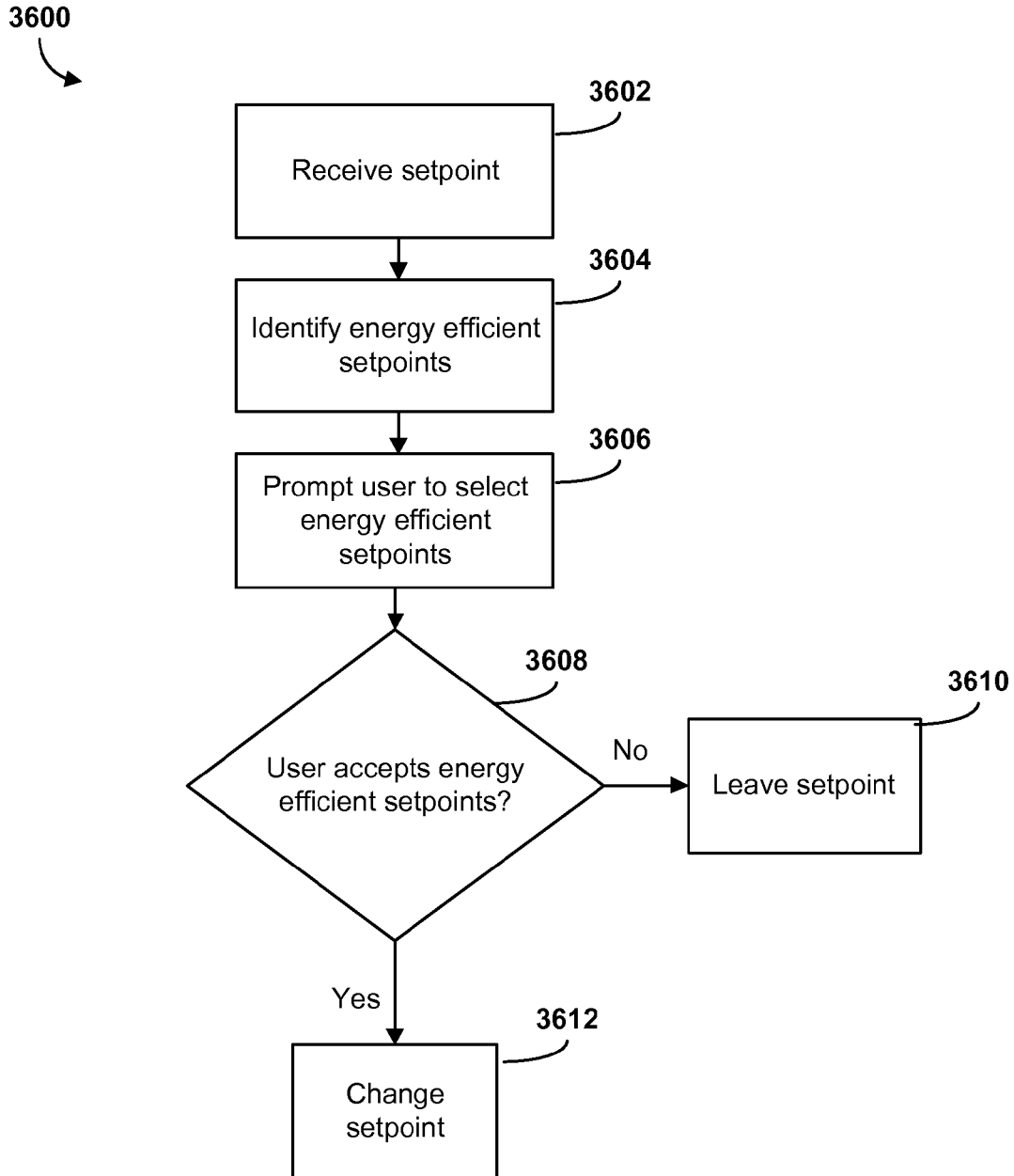

FIG. 36

3700

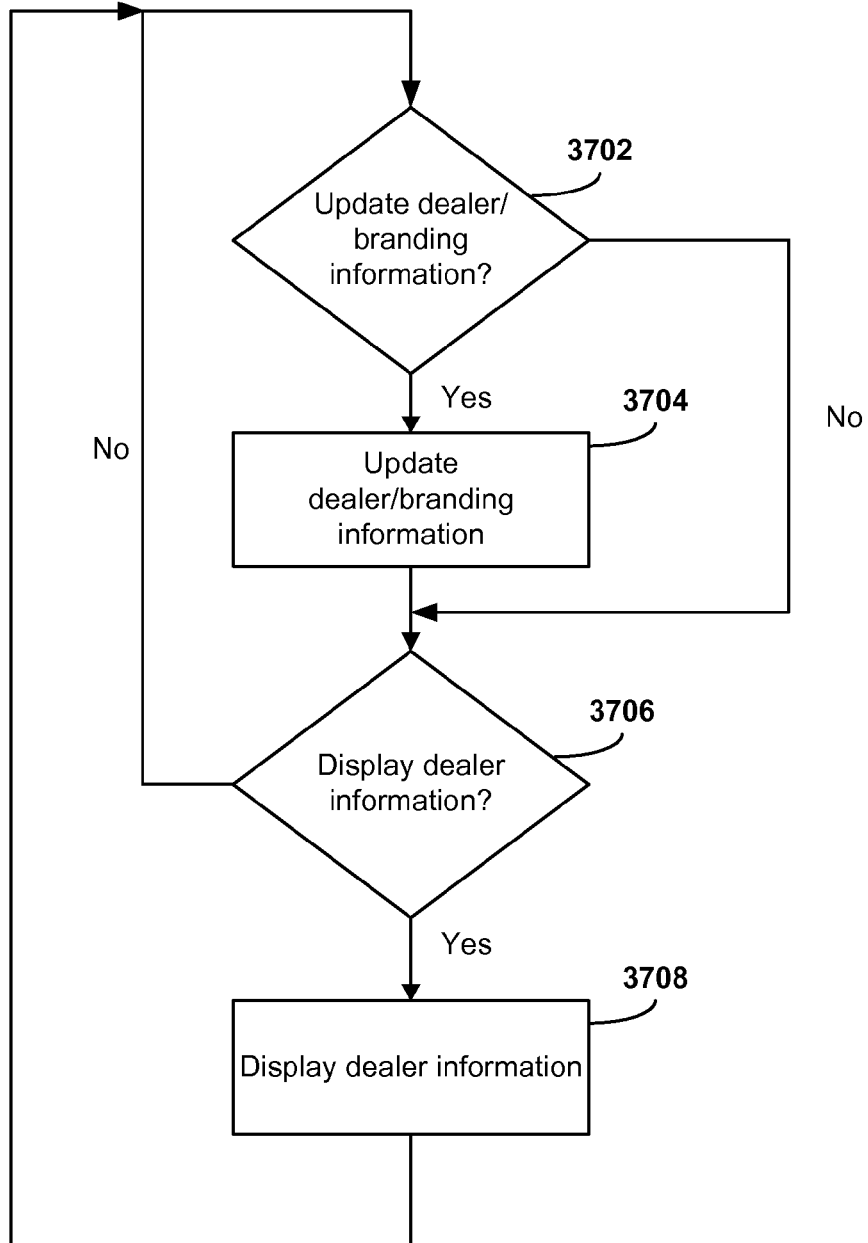

FIG. 37

**THERMOSTAT WITH OCCUPANCY
DETECTION BASED ON LOAD OF HVAC
EQUIPMENT**

CROSS-REFERENCE TO RELATED PATENT
APPLICATION

[0001] This application claims the benefit of and priority to U.S. Provisional Patent Application No. 62/217,788 filed Sep. 11, 2015, U.S. Provisional Patent Application No. 62/217,789 filed Sep. 11, 2015, U.S. Provisional Patent Application No. 62/217,790 filed Sep. 11, 2015, U.S. Provisional Patent Application No. 62/217,791 filed Sep. 11, 2015, U.S. Provisional Patent Application No. 62/367,597 filed Jul. 27, 2016, U.S. Provisional Patent Application No. 62/367,315 filed Jul. 27, 2016, U.S. Provisional Patent Application No. 62/367,614 filed Jul. 27, 2016, U.S. Provisional Patent Application No. 62/367,297 filed Jul. 27, 2016, U.S. Provisional Patent Application No. 62/367,621 filed Jul. 27, 2016, U.S. Provisional Patent Application No. 62/367,291 filed Jul. 27, 2016, U.S. Provisional Application No. 62/247,672 filed Oct. 28, 2015, and U.S. Provisional Application No. 62/275,711 filed Jan. 6, 2016. The entire disclosure of each of these patent applications is incorporated by reference herein.

BACKGROUND

[0002] The present disclosure relates generally to thermostats and more particularly to the improved control of a building or home's heating, ventilating, and air conditioning (HVAC) system through occupancy detection.

[0003] A thermostat is, in general, a component of an HVAC control system. Thermostats sense the temperature of a system and control components of the HVAC in order to maintain a desired setpoint. A thermostat can control a heating or cooling system or an air conditioner. Thermostats are manufactured in many ways, and use a variety of sensors to measure temperature and other desired parameters.

[0004] Conventional thermostats are configured for one-way communication to connected components, and control HVAC systems by turning on or off certain components or regulating flow. Each thermostat may include a temperature sensor and a user interface. The user interface typically includes a display for presenting information to a user and one or more user interface elements for receiving input from a user. To control the temperature of a building or home, a user adjusts the temperature setpoint via the thermostat's user interface.

SUMMARY

[0005] In one aspect, embodiments of the inventive concepts disclosed herein are directed to a thermostat for a building space. The thermostat includes a communications interface and a processing circuit. The communications interface is configured to engage in bidirectional communications with heating, ventilation, or air conditioning (HVAC) equipment and to receive an indication of a current heating or cooling load from the HVAC equipment. The processing circuit is configured to determine an occupancy of the building space based on the indication of the current heating or cooling load received from the HVAC equipment. The processing circuit is further configured to operate the HVAC equipment based on the determined occupancy of the building space.

[0006] In a further aspect, embodiments of the inventive concepts disclosed herein are directed to a method for operating a bidirectional thermostat. The method includes determining a time to setpoint for a building space. The method further includes displaying the time to setpoint on a user interface.

[0007] In a further aspect, embodiments of the inventive concepts disclosed herein are directed to a thermostat for a building space. The thermostat includes a communications interface and a processing circuit. The communications interface is configured to engage in bidirectional communications with heating, ventilation, or air conditioning (HVAC) equipment and to receive an indication of a current heating or cooling load from the HVAC equipment. The processing circuit is configured to determine if a requested setpoint is achievable based on the load.

[0008] Those skilled in the art will appreciate that the summary is illustrative only and is not intended to be in any way limiting. Other aspects, inventive features, and advantages of the devices and/or processes described herein will become apparent in the detailed description set forth herein and taken in conjunction with the accompanying drawings.

BRIEF DESCRIPTION OF THE DRAWINGS

[0009] Implementations of the inventive concepts disclosed herein may be better understood when consideration is given to the following detailed description thereof. Such description makes reference to the annexed drawings, which are not necessarily to scale, and in which some features may be exaggerated and some features may be omitted or may be represented schematically in the interest of clarity. Like reference numerals in the figures may represent and refer to the same or similar element, feature, or function. In the drawings:

[0010] FIG. 1 is an illustration of a commercial or industrial HVAC system that employs heat exchangers, according to an exemplary embodiment.

[0011] FIG. 2 is an illustration of a residential HVAC system that employs heat exchangers, according to an exemplary embodiment.

[0012] FIG. 3 is a block diagram of a HVAC system that employs a control device such as a thermostat, according to an exemplary embodiment.

[0013] FIG. 4 is a block diagram of a prior art system for controlling the temperature of a building space using a wall-mounted thermostat, according to an exemplary embodiment.

[0014] FIG. 5 is a flowchart of a prior art process for controlling the temperature of a building space using a wall-mounted thermostat, according to an exemplary embodiment.

[0015] FIG. 6 is a block diagram of a thermostat with which a user may control the temperature of a building space according to an exemplary embodiment.

[0016] FIG. 7 is a system block diagram of a processing circuit of a thermostat and a remote data storage location according to an exemplary embodiment.

[0017] FIG. 8 is a drawing of a thermostat and its user interface elements according to an exemplary embodiment.

[0018] FIG. 9 is a drawing of the various user interfaces through which a user may control a thermostat according to an exemplary embodiment.

[0019] FIG. 10A is a drawing of various skins and configurations of the user interface of a thermostat according to an exemplary embodiment.

[0020] FIG. 10B is a drawing of a process in which user interface elements of a thermostat may be relocated or redefined according to an exemplary embodiment.

[0021] FIG. 11A is a drawing of a process in which a thermostat detects occupancy according to an exemplary embodiment.

[0022] FIG. 11B is a flowchart of the process shown in FIG. 11A according to an exemplary embodiment.

[0023] FIG. 12A is a flowchart of a process in which a thermostat uses schedule data to determine occupancy according to an exemplary embodiment.

[0024] FIG. 12B is a drawing of various applications and their user interfaces through which a thermostat may obtain schedule data and determine occupancy according to an exemplary embodiment.

[0025] FIG. 12C is a drawing of a scheduling screen of a thermostat, through which the process of handling multiple occupancy homes is shown according to an exemplary embodiment.

[0026] FIG. 13 is a drawing of a process in which a thermostat system adjusts the temperature of a home to a user's preferences prior to her arrival at home according to an exemplary embodiment.

[0027] FIG. 14 is a drawing of a process in which a thermostat system adjusts compressor staging using occupancy according to an exemplary embodiment.

[0028] FIG. 15A is a drawing of a process in which a thermostat communicates with a user's personal electronic device via NFC according to an exemplary embodiment.

[0029] FIG. 15B is a flowchart of the process described in FIG. 15A according to an exemplary embodiment.

[0030] FIG. 16A is a system diagram of the flow of information between a network, a thermostat, and a user's personal electronic device via NFC according to an exemplary embodiment.

[0031] FIG. 16B is a system diagram of the flow of information between a network, a thermostat, and a user's personal electronic device via NFC according to another exemplary embodiment.

[0032] FIG. 17 is a drawing of a process in which a thermostat prepares an analytic report in advance of receiving a request via NFC for the report according to an exemplary embodiment.

[0033] FIG. 18 is a drawing of a process in which a thermostat is locked and unlocked via NFC according to an exemplary embodiment.

[0034] FIG. 19 is a drawing of a process in which a thermostat changes operation of a system using location data obtained via NFC according to an exemplary embodiment.

[0035] FIG. 20 is a drawing of a process in which a thermostat changes operation of a system using feedback from a user obtained via NFC according to an exemplary embodiment.

[0036] FIG. 21 is a drawing of the flow of fault information between a piece of equipment, a thermostat, and a device via NFC according to an exemplary embodiment.

[0037] FIG. 22A is a drawing of a process in which a thermostat modifies its user interface and available features using user identification data obtained via NFC according to an exemplary embodiment.

[0038] FIG. 22B is a drawing of a process in which a thermostat modifies its user interface and available features using user identification data obtained via NFC according to another exemplary embodiment.

[0039] FIG. 23 is a drawing of a process in which a thermostat obtains equipment-specific information via NFC according to an exemplary embodiment.

[0040] FIG. 24 is a drawing of the devices with which a thermostat may communicate according to an exemplary embodiment.

[0041] FIG. 25 is a flowchart detailing the flow of information between a thermostat, HVAC equipment, a network, and network-connected devices and services according to an exemplary embodiment.

[0042] FIG. 26A is a drawing of user interfaces through which a thermostat may display reports which compare and contrast a user's energy consumption and behavior with other similar systems according to an exemplary embodiment.

[0043] FIG. 26B is a drawing of processes through which a thermostat may interact with a user to affect the energy consumption and energy bill of a building space according to an exemplary embodiment.

[0044] FIG. 26C is a flowchart detailing process of testing new settings automatically according to an exemplary embodiment.

[0045] FIG. 26D is a drawing of a process in which a thermostat alerts users that it is unable to reach a setpoint according to an exemplary embodiment.

[0046] FIG. 27 is a drawing of various methods which a user may use to provide input to a thermostat according to an exemplary embodiment.

[0047] FIG. 28 is a drawing of a process in which a thermostat receives a command from a user through text message according to an exemplary embodiment.

[0048] FIG. 29 is a drawing of a method which a thermostat may utilize social media to determine occupancy according to an exemplary embodiment.

[0049] FIG. 30 is a drawing of a thermostat and its user interface through which a brand may promote itself according to an exemplary embodiment.

[0050] FIG. 31 is a drawing of the social media presence of a thermostat according to an exemplary embodiment.

[0051] FIG. 32 is a drawing of the analytics a thermostat may provide according to an exemplary embodiment.

[0052] FIG. 33 is a drawing of a thermostat and an external accessory according to an exemplary embodiment.

[0053] FIG. 34 is a flowchart of a process for determining if a setpoint is achievable, determining the time to reach a setpoint for an achievable setpoint, and serving notifications to a user, according to an exemplary embodiment.

[0054] FIG. 35 is a flowchart of a process for determining if a system fault can be fixed by a homeowner, according to an exemplary embodiment.

[0055] FIG. 36 is a flowchart of a process for determining if setpoints selected by a user are efficient and suggesting energy efficient setpoints to the user, according to an exemplary embodiment.

[0056] FIG. 37 is a flowchart of a process for updating and displaying a dealers contact information, according to an exemplary embodiment.

DETAILED DESCRIPTION

[0057] Before describing in detail the inventive concepts disclosed herein, it should be observed that the inventive concepts disclosed herein include, but are not limited to, a novel structural combination of data/signal processing components, sensors, and/or communications circuits, and not in the particular detailed configurations thereof. Accordingly, the structure, methods, functions, control and arrangement of components, software, and circuits have, for the most part, been illustrated in the drawings by readily understandable block representations and schematic diagrams, in order not to obscure the disclosure with structural details which will be readily apparent to those skilled in the art, having the benefit of the description herein. Further, the inventive concepts disclosed herein are not limited to the particular embodiments depicted in the exemplary diagrams, but should be construed in accordance with the language in the claims.

[0058] Referring generally to the FIGURES, systems and methods for a thermostat are shown according to various exemplary embodiments. The thermostat may include a communications interface and a processing circuit. The communications interface may be configured to engage in bidirectional communications with heating, ventilation, or air conditioning (HVAC) equipment and to receive an indication of a current heating or cooling load from the HVAC equipment. The processing circuit may be configured to determine an occupancy of the building space based on the indication of the current heating or cooling load received from the HVAC equipment. The processing circuit may be further configured to operate the HVAC equipment based on the determined occupancy of the building space.

Building with HVAC System and Thermostat

[0059] FIG. 1 illustrates an exemplary application, in this case an HVAC system for building environmental management that may be a communicating system employing one or more control devices (e.g., thermostats) functioning as system controllers. A building 10 is cooled by a system that includes a chiller 12 and a boiler 14. As shown, chiller 12 is disposed on the roof of building 10 and boiler 14 is located in the basement; however, the chiller and boiler may be located in other equipment rooms or areas next to the building. Chiller 12 is an air cooled or water cooled device that implements a refrigeration cycle to cool water. Chiller 12 may be a stand-alone unit or may be part of a single package unit containing other equipment, such as a blower and/or integrated air handler. Boiler 14 is a closed vessel that includes a furnace to heat water. The water from chiller 12 and boiler 14 is circulated through building 10 by water conduits 16. Water conduits 16 are routed to air handlers 18, located on individual floors and within sections of building 10.

[0060] Air handlers 18 are coupled to ductwork 20 that is adapted to distribute air between the air handlers and may receive air from an outside intake (not shown). Air handlers 18 include heat exchangers that circulate cold water from chiller 12 and hot water from boiler 14 to provide heated or cooled air. Fans, within air handlers 18, draw air through the heat exchangers and direct the conditioned air to environments within building 10, such as rooms, apartments, or offices, to maintain the environments at a designated temperature. A control device 22, shown here as including a thermostat, may be used to designate the temperature of the conditioned air. Control device 22 also may be used to

control the flow of air through and from air handlers 18 and to diagnose mechanical or electrical problems with the air handlers 18. Other devices may, of course, be included in the system, such as control valves that regulate the flow of water and pressure and/or temperature transducers or switches that sense the temperatures and pressures of the water, the air, and so forth. Moreover, the control device may communicate with computer systems that are integrated with or separate from other building control or monitoring systems, and even systems that are remote from the building.

[0061] FIG. 2 illustrates a residential heating and cooling system. The residential heating and cooling system may provide heated and cooled air to a residential structure, as well as provide outside air for ventilation and provide improved indoor air quality (IAQ) through devices such as ultraviolet lights and air filters. In general, a residence 24 will include refrigerant conduits 26 that operatively couple an indoor unit 28 to an outdoor unit 30. Indoor unit 28 may be positioned in a utility room, an attic, a basement, and so forth. Outdoor unit 30 is typically situated adjacent to a side of residence 24 and is covered by a shroud to protect the system components and to prevent leaves and other contaminants from entering the unit. Refrigerant conduits 26 transfer refrigerant between indoor unit 28 and outdoor unit 30, typically transferring primarily liquid refrigerant in one direction and primarily vaporized refrigerant in an opposite direction.

[0062] When the system shown in FIG. 2 is operating as an air conditioner, a coil in outdoor unit 30 serves as a condenser for recondensing vaporized refrigerant flowing from indoor unit 28 to outdoor unit 30 via one of the refrigerant conduits 26. In these applications, a coil of the indoor unit, designated by the reference numeral 32, serves as an evaporator coil. Evaporator coil 32 receives liquid refrigerant (which may be expanded by an expansion device, not shown) and evaporates the refrigerant before returning it to outdoor unit 30.

[0063] Outdoor unit 30 draws in environmental air through its sides as indicated by the arrows directed to the sides of the unit, forces the air through the outer unit coil using a fan (not shown), and expels the air as indicated by the arrows above the outdoor unit. When operating as an air conditioner, the air is heated by the condenser coil within the outdoor unit and exits the top of the unit at a temperature higher than it entered the sides. Air is blown over indoor coil 32 and is then circulated through residence 24 by means of ductwork 20, as indicated by the arrows entering and exiting ductwork 20. The overall system operates to maintain a desired temperature as set by system controller 22. When the temperature sensed inside the residence is higher than the set point on the thermostat (plus a small amount), the air conditioner will become operative to refrigerate additional air for circulation through the residence. When the temperature reaches the set point (minus a small amount), the unit will stop the refrigeration cycle temporarily.

[0064] When the unit in FIG. 2 operates as a heat pump, the roles of the coils are simply reversed. That is, the coil of outdoor unit 30 will serve as an evaporator to evaporate refrigerant and thereby cool air entering outdoor unit 30 as the air passes over the outdoor unit coil. Indoor coil 32 will receive a stream of air blown over it and will heat the air by condensing a refrigerant.

[0065] FIG. 3 is a block diagram of an HVAC system 42 that includes the control device 22, indoor unit 28 function-

ing as an air handler, and outdoor unit **30** functioning as a heat pump. Refrigerant flows through system **42** within a closed refrigeration loop **44** between outdoor unit **30** and indoor unit **28**. The refrigerant may be any fluid that absorbs and extracts heat. For example, the refrigerant may be hydrofluorocarbon (HFC) based R-410A, R-407C, or R-134a.

[0066] The operation of indoor and outdoor units **28** and **30** is controlled by control circuits **48** and **46**, respectively. The control circuits **46** and **48** may execute hardware or software control algorithms to regulate the HVAC system. According to exemplary embodiments, the control circuits may include one or more microprocessors, analog to digital converters, non-volatile memories, and interface boards. In certain embodiments, the control circuits may be fitted with or coupled to auxiliary control boards that allow conventional 24 VAC wiring to be controlled through serial communications.

[0067] The control circuits **46** and **48** may receive control signals from control device **22** and transmit the signals to equipment located within indoor unit **28** and outdoor unit **30**. For example, outdoor control circuit **46** may route control signals to a motor **50** that powers a fan **52** and to a motor **54** that powers a compressor **56**. Indoor control circuit **48** may route control signals to a motor **58** that powers a fan **60**. The control circuits also may transmit control signals to other types of equipment such as valves **62** and **64**, sensors, and switches.

[0068] According to exemplary embodiments, control device **22** may communicate with control circuits **46** and **48** by transmitting communication packets over a serial communication interface. Control device **22** may function as the master system controller while control circuits **46** and **48** operate as slave devices. In certain embodiments, control device **22** may send a ping message to discover connected slave devices and their properties. For example, control circuits **46** and **48** may transmit an acknowledgement message in response to receiving a ping message from control device **22**. Control circuits **46** and **48** also may transmit information, in response to requests from control device **22**, identifying the type of unit and specific properties of the unit. For example, control circuit **46** may transmit a signal to control device **22** indicating that it controls a two-stage heat pump with auxiliary heat and a bonnet sensor. Control circuits **46** and **48** also may transmit signals identifying terminal connections and jumper settings of the control circuits.

[0069] Control device **22** may operate to control the overall heating and cooling provided by indoor and outdoor units **28** and **30**. Indoor and outdoor units **28** and **30** include coils **66** and **32**, respectively, that both operate as heat exchangers. The coils may function either as an evaporator or a condenser depending on the heat pump operation mode. For example, when heat pump system **42** is operating in cooling (or "AC") mode, outside coil **32** functions as a condenser, releasing heat to the outside air, while inside coil **66** functions as an evaporator, absorbing heat from the inside air. When heat pump system **42** is operating in heating mode, outside coil **32** functions as an evaporator, absorbing heat from the outside air, while inside coil **66** functions as a condenser, releasing heat to the inside air. A reversing valve may be positioned on closed loop **44** to control the direction of refrigerant flow and thereby to switch the heat pump between heating mode and cooling mode.

[0070] Heat pump system **42** also includes two metering devices **62** and **64** for decreasing the pressure and temperature of the refrigerant before it enters the evaporator. The metering devices also regulate the refrigerant flow entering the evaporator so that the amount of refrigerant entering the evaporator equals, or approximately equals, the amount of refrigerant exiting the evaporator. The metering device used depends on the heat pump operation mode. For example, when heat pump system **74** is operating in cooling mode, refrigerant bypasses metering device **62** and flows through metering device **64** before entering inside coil **66**, which acts as an evaporator. In another example, when heat pump system **42** is operating in heating mode, refrigerant bypasses metering device **64** and flows through metering device **62** before entering outside coil **32**, which acts as an evaporator. According to other exemplary embodiments, a single metering device may be used for both heating mode and cooling mode. The metering devices typically are thermal or electronic expansion valves, but also may be orifices or capillary tubes.

[0071] The refrigerant enters the evaporator, which is outside coil **32** in heating mode and inside coil **66** in cooling mode, as a low temperature and pressure liquid. Some vapor refrigerant also may be present as a result of the expansion process that occurs in metering device **62** or **64**. The refrigerant flows through tubes in the evaporator and absorbs heat from the air changing the refrigerant into a vapor. In cooling mode, the indoor air flowing across the multichannel tubes also may be dehumidified. The moisture from the air may condense on the outer surface of the multichannel tubes and consequently be removed from the air.

[0072] After exiting the evaporator, the refrigerant flows into compressor **56**. Compressor **56** decreases the volume of the refrigerant vapor, thereby, increasing the temperature and pressure of the vapor. The compressor may be any suitable compressor such as a screw compressor, reciprocating compressor, rotary compressor, swing link compressor, scroll compressor, or turbine compressor.

[0073] From compressor **56**, the increased temperature and pressure vapor refrigerant flows into a condenser, the location of which is determined by the heat pump mode. In cooling mode, the refrigerant flows into outside coil **32** (acting as a condenser). Fan **52**, which is powered by motor **50**, draws air across the tubes containing refrigerant vapor. According to certain exemplary embodiments, the fan may be replaced by a pump that draws fluid across the multichannel tubes. The heat from the refrigerant is transferred to the outside air causing the refrigerant to condense into a liquid. In heating mode, the refrigerant flows into inside coil **66** (acting as a condenser). Fan **60**, which is powered by motor **58**, draws air across the tubes containing refrigerant vapor. The heat from the refrigerant is transferred to the inside air causing the refrigerant to condense into a liquid.

[0074] After exiting the condenser, the refrigerant flows through the metering device (**62** in heating mode and **64** in cooling mode) and returns to the evaporator (outside coil **32** in heating mode and inside coil **66** in cooling mode) where the process begins again.

[0075] In both heating and cooling modes, motor **54** drives compressor **56** and circulates refrigerant through reversible refrigeration/heating loop **44**. The motor may receive power either directly from an AC or DC power source or from a variable speed drive (VSD). The motor may be a switched

reluctance (SR) motor, an induction motor, an electronically commutated permanent magnet motor (ECM), or any other suitable motor type.

[0076] The operation of motor 54 is controlled by control circuit 46. Control circuit 46 may receive control signals from control device 22. In certain embodiments, control device may receive information from a sensor 68 that measures the ambient indoor air temperature. Control device 22 then compares the air temperature to the temperature set point (which may be input by a user) and engages compressor motor 54 and fan motors 50 and 58 to run the cooling system if the air temperature is above the temperature set point. In heating mode, control device 22 compares the air temperature from sensor 68 to the temperature set point and engages motors 50, 54, and 58 to run the heating system if the air temperature is below the temperature set point.

[0077] The control circuit 46 and control device 22 also may initiate a defrost cycle when the system is operating in heating mode. When the outdoor temperature approaches freezing, moisture in the outside air that is directed over outside coil 32 may condense and freeze on the coil. Sensors may be included within outdoor unit 30 to measure the outside air temperature and the temperature of outside coil 32. These sensors provide the temperature information to the control circuit 46 which determines when to initiate a defrost cycle.

[0078] Referring now to FIG. 4, a system 400 for monitoring and controlling the temperature of a building space is shown, according to an exemplary embodiment. System 400 is shown to include a thermostat 404 installed within a building space 402. Typically, thermostat 404 is mounted on a wall within building space 402. Thermostat 404 is shown to include user interface 406 and a temperature sensor 408. User interface 406 includes an electronic display for presenting information to a user 410 and one or more physical input devices (e.g., a rotary knob, pushbuttons, manually-operable switches, etc.) for receiving input from a user 410. Temperature sensor 408 measures the temperature of building space 402 and provides the measured temperature to user interface 406.

[0079] Thermostat 404 communicates with a controller 412. In various embodiments, controller 512 may be integrated with thermostat 404 or may exist as a separate controller (e.g., a field and equipment controller, a supervisory controller, etc.) that receives input from thermostat 404. Thermostat 404 may send temperature measurements and user-defined temperature setpoints to controller 412. Controller 412 uses the temperature measurements and the setpoints to generate a control signal for HVAC equipment 414. The control signal causes HVAC equipment 414 to provide heating and/or cooling for building space 402.

[0080] Referring now to FIG. 5, a process 500 for monitoring and controlling the temperature of a building space is shown, according to an exemplary embodiment. Process 500 may be performed by system 400, as described with reference to FIG. 4. In process 500, thermostat 404 measures the temperature of building space 402 (step 502). User 410 views the measured temperature and adjusts the temperature setpoint via user interface 406 of thermostat 404 (step 504). Thermostat 404 sends the measured temperature and the setpoint to controller 412 (step 506). Controller 412 uses the measured temperature and the setpoint to generate and provide a control signal to HVAC equipment 414 (step 508).

HVAC equipment 414 operates in accordance with the control signal to provide heating/cooling to building space 402 (step 510).

Occupancy Based Control and Operation

[0081] In FIG. 6, a block diagram of thermostat 600 is shown to include sensors 602, 604, and 606, processing circuit 608, data communications interface 610, and user interface 612. In some embodiments, sensors 602-606 are used to detect occupancy (i.e., occupancy sensors). It is contemplated that sensors 602-606 could be, in some embodiments, motion sensors, cameras, microphones, capacitive sensors, or any number of other sensors. Sensors 602-606 could be any number of sensors. Sensors 602-606 could be cameras which detect heat signatures in some embodiments. Sensors 602-606 may detect separate objects and distinguish between humans and other objects. Sensors 602-606 could be any transducers which detect some characteristic of their respective environment and surroundings.

[0082] Still referring to FIG. 6, thermostat 600 is capable of bi-directional communication with equipment through data communications interface 610. Thermostat 600 may communicate to a network or the Internet through the data communications interface 610. In some embodiments, data communications interface 610 is a network interface for thermostat 600. In some embodiments, the networks include at least one of a wireless Zigbee network, a Bluetooth connection, Ethernet, Wi-Fi, and any other such network. In some embodiments, the data communications interface 610 includes a near field communication module configured to interact with near field communication enabled devices. In some embodiments, the near field communication module is configured to exchange information in a peer-to-peer connection with a user device. In some embodiments, thermostat 600 may be able to communicate with a variety of devices through a network. For example, thermostat 600 may be able to communicate with other network enabled appliances and systems in a user's home such as a security system or a refrigerator or light system. In other embodiments, thermostat 600 may be able to communicate directly with devices.

[0083] Now referring to FIG. 7, processing circuit 608 is shown to include a processor 702 and memory 704. Processor 702 may be a general purpose or specific purpose processor, an application specific integrated circuit (ASIC), one or more field programmable gate arrays (FPGAs), a group of processing components, or other suitable processing components. Processor 702 is configured to execute computer code or instructions stored in memory 704 or received from other computer readable media (e.g., CDROM, network storage, a remote server, etc.).

[0084] Memory 704 may include one or more devices (e.g., memory units, memory devices, storage devices, etc.) for storing data and/or computer code for completing and/or facilitating the various processes described in the present disclosure. Memory 704 may include random access memory (RAM), read-only memory (ROM), hard drive storage, temporary storage, non-volatile memory, flash memory, optical memory, or any other suitable memory for storing software objects and/or computer instructions. Memory 704 may include database components, object code components, script components, or any other type of information structure for supporting the various activities and information structures described in the present disclosure.

Memory 704 may be communicably connected to processor 702 via processing circuit 134 and may include computer code for executing (e.g., by processor 702) one or more processes described herein. When processor 702 executes instructions stored in memory 704 for completing the various activities described herein, processor 702 generally configures thermostat 600 (and more particularly processing circuit 134) to complete such activities.

[0085] Memory 704 is shown to include occupancy detector 706, occupancy identifier 708, occupancy predictor 710, data analyzer 712, system analyzer 714, and voice recognition module 716. Occupancy detector 706 processes data received from sensors 602-606 to determine whether occupancy has been detected. Occupancy identifier 708 processes occupancy data collected to determine which user or users are home. Occupancy predictor 710 processes calendar and scheduling data to determine when a user or users will be home, which user or users will be home, and the appropriate course of action when overlap and conflicting preferences occur.

[0086] Processing circuit 608 is shown to include a control circuit 722 which includes a controller 724, and a scheduler 726. Controller 724 may be an embodiment of controller 512, and is able to communicate with and send commands to connected equipment. Scheduler 726 is a module which is configured to receive calendar and schedule data to organize and send commands to connected equipment.

[0087] Processing circuit 608 is also shown to include a data logger 720. System 700 is shown to include remote data storage 718. In some embodiments, remote data storage 718 is at least one of RAM, ROM, EPROM, EEPROM, CD-ROM or other optical disk storage, hard drive, magnetic disk storage or other magnetic storage devices, or any other medium which can be used to store data. Data logger 720 may record data in memory 704 and the remote data storage 718. In some embodiments, processing circuit 608 may store data in remote data storage 718. In some embodiments, remote data storage 718 is located inside processing circuit 608. In some embodiments, remote data storage 718 is outside processing circuit 608 but is located inside thermostat 600. While storing data locally may reduce access time, the cost of providing suitable storage space may discourage user adoption. Remote data storage 718 is remote from processing circuit 608 and may be accessed through any number of communications protocols.

[0088] Referring now to FIG. 8, thermostat 600 is shown to have a display 802 and a frame 804. In some embodiments, display 802 is touch-sensitive, and may be a capacitive LCD screen. In some embodiments, frame 804 is touch-sensitive. In some embodiments, a capacitive layer may extend from display 802 out over frame 804. Thermostat may be configured to have buttons 806-812 on frame 804. Buttons 806-812 on frame 804 are touch sensitive buttons. Buttons 806-812 are not physical buttons, and cannot be seen. Buttons 806-812 are predefined areas of the capacitive layer which extends over frame 804. In some embodiments, buttons 806-812 are associated with large areas of frame 804 and are not finely sensitive.

[0089] Referring now to FIG. 9, exemplary user interfaces 902, 904, and 908 are shown. User interfaces 902-908 are used to interact with and control thermostat 600. User interface 902 is an exemplary embodiment of a mobile application user interface which can be used on personal electronic devices such as smartphones or tablets. User

interface 904 is an exemplary embodiment of user interface 612, and is physically integrated with thermostat 600. User interface 908 is an exemplary embodiment of a web-based application user interface which can be accessed through any device connected to the Internet. In some embodiments, a network-based application may be used instead of a web-based application, and may allow users to control thermostat 600 through any device which is connected to a local area network (LAN), regardless of Internet connectivity. It is understood that the embodiments described and shown in FIG. 9 are only a few of many different possibilities. In some embodiments, it is possible for a user to queue commands through user interfaces 902-908 to send to thermostat 600. In some embodiments, any combination of the above mentioned methods may be available options to control thermostat 600.

[0090] Referring now to FIG. 10A, different skins 1002, 1004, 1006, and 1008 are shown. Skins may change the look, feel, and functionality of thermostat 600. Skins may be used to tailor functionality and complexity of operation to a user's preference and comfort level. Skins may be software configurations which dictate the appearance of user interface 612 of thermostat 600. Skins 1002 and 1006 are exemplary embodiments of software configuration skins. Skin 1002 is an exemplary embodiment of a skin created for a user who wishes to be able to access and use all features of their thermostat 600. Skin 1006 is an exemplary embodiment of a skin created for a user who only wishes to control the temperature of their home, and does not wish to see any other options or controls.

[0091] Skins can be stickers which are applied to the outside of thermostat 600 to frame 804. It is understood that physical skins may be in the form of any physical applique and is not limited to stickers. The buttons shown on skins 1004 and 1008 are visible only on the physical skins, and are not visible or physical buttons on frame 804. In some embodiments, a wirelessly communicating tag, attached to the physical skin, interacts with thermostat 600 to configure the functionality of thermostat 600. For example, an RFID tag is attached to a skin sticker which dictates portions of frame 804 which correspond to buttons on the sticker.

[0092] Referring now to FIG. 10B, a process 1050 through which a skin may be customized is shown. Users may be able to download an application or use a web-based application, embodied in FIG. 10B as 1052, to customize skins to their preferred settings. Users may be able to change the placement and priority of certain features of user interface 612 of thermostat 600. Users may be able to move icons, screens, or buttons on display 802. It is shown that the movement of button icons 1060, 1062, and 1062 in web-based application 1052 correspond to movement of touch-sensitive buttons 1054, 1056, and 1058 on thermostat 600. The movement of screens 1070 and 1072 in web-based application 1052 is shown to correspond to movement of screens 1066 and 1068 on thermostat 600. Changes which could be made to user interface 612 of thermostat 600 include backgrounds, icons, macros, scenes, etc. In some embodiments, skins may change the sound settings of thermostat 600. It is conceivable that any setting on thermostat 600 may be adjusted by a user through the use of skins. There could be any number of skins, which may be user customizable.

[0093] In some embodiments, users may be able to design their own physical skin and print it out at a location with a

suitable fabrication center. In another embodiment, users may need to send their designs to the manufacturer or a dealer to fabricate. In some embodiments, any combination of the above mentioned methods of customization may be available to users.

[0094] Determining the occupancy of a home allows thermostat **600** to make energy efficient operating decisions by reducing conditioning and power consumption when a home is unoccupied. User comfort may be increased when thermostat **600** is able to anticipate occupancy and condition the home to user preferences by the time the home is occupied. Occupancy based operation and control of an HVAC system allows users to conserve energy and arrive home to a comfortable environment without requiring a large amount of effort on the part of the user.

[0095] Referring now to FIG. 11A, an exemplary situation **1100** in which thermostat **600** detects occupancy of a home is shown. Thermostat **600** may detect occupancy through sensor **1102**, which may be an embodiment of sensors **602-606**. In some embodiments, thermostat **600** may detect occupancy through communication with external object **1104**. Object **1104** may be any device. In some embodiments, object **1104** is an electronic device capable of communicating with thermostat **600**. In various embodiments, object **1104** may be a user's cellphone, laptop, tablet, or any portable electronic device. In some embodiments, object **1104** is a dongle which may be compatible with thermostat **600** or any other objects which may communicate with thermostat **600**. In some embodiments, object **1104** is a wearable object such as a necklace, a watch, or a fitness tracker. Object **1104** may be a business card or an RFID card. Thermostat **600** may detect the time at which occupancy is detected. In some embodiments, thermostat **600** time-stamps logged data to be used in later analysis.

[0096] FIG. 11B describes an exemplary process **1150** in which thermostat **600** may detect occupancy and alter operations of a connected system. Thermostat **600** waits for an input to be received at sensor **1102** (step **1152**). In step **1154**, an input is received. The input may be a noise, a movement, a heat signature, or a communication signal. Once the input is received, it must be processed by occupancy detector **706** of memory **704** in step **1156**. In step **1157**, a determination is made whether occupancy has been detected. If occupancy has been detected, an operation command is issued from thermostat **600** to the connected system (step **1158**). If occupancy has not been detected, the process repeats, and thermostat **600** waits for an input to be received in step **1152**. In some embodiments, thermostat **600** may receive a communication signal from object **1104**, which may be through NFC, WiFi, Bluetooth, or any other communication protocol.

[0097] Referring now to FIG. 12A, thermostat **600** may determine occupancy based on a schedule or calendar. In some embodiments, a user is able to input a schedule directly to the thermostat. In other embodiments, thermostat **600** may support integration with existing calendar applications. In step **1202**, occupancy predictor **710** of memory **704** receives calendar data or a schedule from a user. Occupancy predictor **710** then determines when the user does not have any events scheduled in step **1204**. In some embodiments, thermostat **600** may allow a user to input a schedule of times when she expects to be home. The periods of time identified in step **1204** are then stored as predicted periods of occupancy (step **1206**). In some embodiments, thermostat **600**

may store the predicted occupancy periods in remote data storage **718**. In other embodiments, thermostat **600** may store the predicted occupancy periods locally in memory **704**. In step **1208**, operation commands are issued from thermostat **600** to the connected system based on the occupancy periods stored and the associated user's preferences.

[0098] In FIG. 12B, an exemplary embodiment of methods with which users may input calendar data is shown. Existing calendar application **1240** accessed on a mobile device with user Jack's schedule is shown. Existing calendar application **1242** accessed via a browser with user Jill's schedule is shown. In some embodiments, thermostat **600** may communicate with Jack or Jill's Google, iOS, or Outlook calendar and determine when he or she will be home based upon the appointment and event information obtained. Thermostat **600** may decide that a user will be home whenever he does not have an appointment scheduled. In some embodiments, thermostat **600** may be programmed to assume that a user will not be home on weekdays during the work day, in addition to appointments and engagements outside of those hours. Thermostat **600** may be able to determine when a user will be home based upon location information associated with events in his calendar. In some embodiments, thermostat **600** may be able to detect the network connectivity of a user's personal device—whether it is connected—to determine occupancy. In some embodiments, thermostat **600** may be able to detect the network connectivity of a user's personal device to determine what area of the home the user is in. Thermostat **600** may be able to control conditioning to different areas, or zones, of a home depending on the duct and flow work. The network **1244**, to which Jack is connected, may be identified and used to determine that he is in zone **1** of the home. The network **1246**, to which Jill is connected, may be identified and used to determine that she is in zone **2** of the home.

[0099] In a multiple occupancy home, thermostat **600** may be able to make operating decisions based on occupancy. Thermostat **600** may be able to operate on different schedules for different detected users. In one embodiment, users may each enter their own schedule to thermostat **600** directly. In other embodiments, thermostat **600** may be able to communicate with external calendars and applications to determine a user's schedule. Thermostat **600** may be able to detect which user is home and adjust the operating schedule to accommodate that user's preferences. For example, in a home with multiple occupants and different schedules to keep to, thermostat may detect which user is home, and make operating decisions based on that user's settings and schedule. It is possible that thermostat **600** may have a different setting for guests or periodic visitors such as a housekeeper or a nanny. For example, thermostat **600** may operate at lower capacity when only the housekeeper is in the home, as opposed to when the entire family residing in the home is present.

[0100] In a multiple occupancy home, it is common for users to have different schedules. Referring now to FIG. 12C, thermostat **600** is shown making operating decisions based on the intersection of schedules of the occupants. Thermostat **600** may use calendar information to determine how many users are home and adjust operation accordingly. Thermostat **600** may make decisions on operating procedure when more than one user is home. In one embodiment, thermostat **600** may compromise when users with different preferences are home. The process described in FIG. 12A

may be adapted for situations in which conflicting preferences exist for multiple occupancy homes. Thermostat **600** may receive the schedule of two occupants of the home. Thermostat **600** compares the calendars detect occupancy based on when either occupant does not have an event scheduled. Thermostat **600** could create a merged calendar of the free times of the users. If only one user is home, his settings are applied, as shown in thermostat **600** schedule block **1274**. Thermostat **600** determines an overlap in occupancy has been detected. For example, if one user prefers the home to be at 72° F. while another user prefers the home to be at 68° F., and both users are home, thermostat **600** may compromise and set the temperature to 70° F. as shown in thermostat **600** schedule block **1272**. In another embodiment, there may be a master user whose settings will override other users' settings. For example, one user prefers the home to be at 72° F. while another user prefers the home to be at 68° F.; however, the first user is the master user, so her settings are conveyed to the equipment as shown in thermostat **600** schedule block **1276**. In another embodiment, if a user is already at home but the master user is detected afterward, her settings may be applied automatically upon her detection. In yet another embodiment, thermostat **600** may keep an existing user's preferences until the master user commands an update.

[0101] Referring now to FIG. **13**, thermostat **600** may be able to determine the operating conditions needed to reach a user's desired settings by the time they arrive. In one embodiment, thermostat **600** allows a user to program directly into thermostat **600** when she expects to be home and what settings she would like it to be. In another embodiment, thermostat **600** may access a user's external calendar and determine when she will be home as shown in thermostat **600** schedule block **1302**. For example, if Jill is scheduled to be home at 1700 and would like her home to be at 72° F. when she arrives, thermostat **600** may begin to cool her home from a starting point of 76° F. at 1600, as shown in situational snapshot **1304**. By 1630, as Jill is travelling, thermostat **600** has already cooled her home to 74° F. as shown in situational snapshot **1306**. When Jill arrives home at 1700, her home is already at 72° F., as shown in situational snapshot **1308**. In another embodiment, thermostat **600** may be able to receive communication from a user while they are away to set their home at a certain temperature, which thermostat **600** may immediately command.

[0102] Thermostat **600** may be able to determine what kind of activities are occurring in the home and change operation based on occupancy level. In some embodiments, thermostat **600** is able to detect separate occupants of the home. In other embodiments, thermostat **600** determines occupancy level based on communication with connected equipment. For example, thermostat **600** may be able to estimate occupancy based on assumed load seen by the AC unit. In another embodiment, thermostat **600** may obtain activity information from a fitness tracker to determine the amount of activity related to a specific user. In yet another embodiment, thermostat **600** may use sensor **1102** to detect the amount of movement or activity occurring. For example, thermostat **600** may determine that a user is currently occupying a room, but that there is a low level of activity. Thermostat **600** may determine that the user is sleeping, and adjust conditioning accordingly. Thermostat **600** may deter-

mine that many people are in one room, and that there is a high level of activity, and increase conditioning accordingly.

[0103] Referring now to FIG. **14**, thermostat **600** may adjust compressor staging in a connected AC unit based on occupancy. In one embodiment, thermostat **600** may detect a change in occupancy and adjust compressor staging accordingly. For example, thermostat **600** may detect that more motion is occurring, and increase staging to maintain temperature. In another embodiment, thermostat **600** may analyze the occupancy and activity level of the home and determine an appropriate staging progression. For example, there may currently be one person detected by thermostat **600**, as shown in snapshot **1402**. The compressor is currently operating in stage **1**, as there is low occupancy. In snapshot **1404**, thermostat **600** may detect from the home network that there are five people in the home, and command the compressor, currently at stage **1**, to go through stages **2**, **3**, and **4** to stage **5**. Thermostat **600** may then detect that there are ten people in the home, and command the compressor, currently at stage **1**, to go directly to stage **5**.

[0104] Thermostat **600** may be able to determine with some granularity where in the home a user is. In some embodiments, thermostat **600** communicates with a user's personal device **1104** and obtains GPS data to determine whether a user is home, and if so, where he is. In some embodiments, thermostat **600** uses a geofencing to determine what zone or room of the home a user is in and adjusts operation accordingly. Geofencing allows a boundary to be defined based on locational information. Thermostat **600** may adjust operation based on detected occupancy and location. For example, if a user is detected on the upper floor of a home, thermostat **600** may increase conditioning on the upper floor. Thermostat **600** could detect that there are no occupants on the lower floor and decrease conditioning to the lower floor.

[0105] Thermostat **600** may allow users to set their occupancy status through an application or as an input to thermostat **600**. In some embodiments, a user may input their occupancy status through an object **1104** such as a cellphone. For example, Jill may set her status as "away." In some embodiments, different users may have different settings, and thermostat **600** may determine the level of occupancy from the status information received. In some embodiments, thermostat **600** is able to automatically update a user's status based on the connectivity of an object **1104** which, in some embodiments, is a cellphone.

[0106] In some embodiments, thermostat **600** may send push notifications to a user's cellphone **1104** depending on their detected location. For example, if Jill is detected to have left her home, thermostat **600** may display a prompt asking if she would like to set her status as "away." In some embodiments, when a user is away, the system associated with thermostat **600** goes into an energy efficient state which may not be comfortable to occupants remaining in the home. Thermostat **600** may allow a master user to override all commands given to thermostat **600** from other users. In some embodiments, if a master user is away, the system will go into an energy efficient state despite the occupancy of the home by other users. Thermostat **600** may display a warning to the master user that another user is still home, and ask whether she would still like to set her status as "away." For example, if Jill is the master user and is detected leaving her home, thermostat **600** may ask whether she would like to set her status to "away." If she chooses "Yes", thermostat **600**

may warn her that Jack is still home, and that the system will go into an energy efficient state despite his occupancy. Thermostat **600** may ask whether a user is sure she wishes to change her status. If a user selects “Yes”, the system will execute whatever command is associated with no occupancy.

[**0107**] Thermostat **600** may detect a user’s location based on a zone sensor which may communicate through any communications protocol. For example, the zone sensor may use Bluetooth, NFC, WiFi, or any other communications protocol. In some embodiments, thermostat **600** may indicate the success or failure of detection of a user through the playing of a sound. In some embodiments, the sound may be unique for success or for failure. In some embodiments, an accompanying indicator may be displayed. For example, a message may be displayed, warning the user that they were not authenticated. The indicator may be as simple as a flashing LED.

[**0108**] Thermostat **600** may be adjust its communication behavior based on detected occupancy. In one embodiment, thermostat **600** may determine that a user is in the kitchen while thermostat **600** is in the living room. Thermostat **600** may attempt to communicate any changes in operation to the user through a speaker in the kitchen, or through the user’s portable electronic device since the user cannot see the screen of thermostat **600**.

[**0109**] Thermostat **600** may be able to learn from user behavior, and store data to adapt operation and better serve users. In one embodiment, thermostat **600** may analyze the location data obtained and determine the location in which a user spends a majority of his time in. Thermostat **600** may set that location as a priority to condition over all locations in the home. In another embodiment, thermostat **600** may allow users to set their preferred priority space.

[**0110**] Thermostat **600** may be able to learn from outside sources how to adjust operation. In some embodiments, thermostat **600** stores the date and time at which occupancy is being detected. Thermostat **600** may determine, based on the season, what an appropriate conditioning command might be. Thermostat **600** may be able to learn what an appropriate adjustment to standard operating conditions might be based on historical data collected from the home.

[**0111**] Thermostat **600** may make adjustments to standard operating condition based on the frequency at which occupancy is detected. A user is detected at one time. Some amount of time later, the user is detected again. Thermostat **600** will make an operating decision based on the time in between detections. In one embodiment, sensors **602-606** are one motion sensor and thermostat **600** detects occupancy purely on motion. For example, a pet cat may walk past the sensor several times a minute, causing thermostat **600** to detect “high occupancy.” However, thermostat **600** may have a threshold frequency past which it decides that it should not be considering each detection as a separate event. In another embodiment, thermostat **600** may detect a user’s device connecting to the home network at a high frequency, possibly due to faulty components. Thermostat **600** may decide that the high level of activity is not genuine, and cancel adjustments accordingly.

[**0112**] Thermostat **600** may receive identifying information when detecting occupancy. In one embodiment, thermostat **600** may use sensors **602-606**, in one embodiment, a plurality of cameras, to detect and identify separate users. In another embodiment, thermostat **600** may receive user infor-

mation from the user’s portable electronic device. In yet another embodiment, thermostat **600** may communicate with the network to receive user information from devices connected to the network. Thermostat **600** may store personalized settings and control configurations for each associated device. Thermostat **600** may load settings from the network to adjust the user interface in accordance with the user detected. For example, a user may prefer to have a user interface with only temperature adjustment, whereas another user may prefer to have a user interface which allows her to access every option available. Thermostat **600** may allow users to create a personalized home screen which displays information the user is most interested in.

[**0113**] Thermostat **600** may display different information based on the user detected. In some embodiments, thermostat **600** is able to distinguish between occupants based on information received from sensors **602-606**. One of sensors **602-606** may be a camera, an IR sensor, a microphone, or any other conceivable sensor which could be used to detect occupancy. Thermostat **600** may only display the current temperature if a child or a pet is detected. In some embodiments, thermostat **600** may detect the user based on their identifiable personal device, and display a screen of her choice. For example, if a user prefers to see how long it will take to reach her settings, she can select that screen as the default screen when she is detected in the home. In another embodiment, thermostat **600** may display the most used screen. For example, if the temperature screen is used the most out of all screens available, thermostat **600** may display the temperature screen whenever occupancy is detected.

Near Field Communication Based Control and Operation

[**0114**] Thermostat **600** may be able to base control and operation decisions on data obtained through near field communication (NFC). In one embodiment, a user brings personal electronic device **1502** within range of an NFC transmitter integrated with thermostat **600**, as shown in FIG. **15A**. This may be referred to as “checking in.” FIG. **15B** describes process **1550**, an exemplary embodiment of the method. In step **1552**, thermostat **600** may receive identifying information through NFC. This information may include preferred settings for thermostat **600**. Upon authentication and identification of the user through electronic device **1502**, thermostat **600** is receptive to commands (step **1554**). In some embodiments, thermostat **600** may provide an audible indication that the scan has occurred. For example, thermostat **600** may beep to let users know that scanning has been completed. In other embodiments, thermostat **600** may provide visual feedback that scanning has occurred. For example, thermostat **600** may flash display **802**. In another embodiment thermostat **600** may communicate to device **1502** to provide an indication, such as beeping, flashing, or vibrating, that scanning has occurred. Thermostat **600** may alert the user that scanning has occurred in any number of ways not limited to those enumerated. Upon receiving a command in step **1556**, thermostat **600** then transmits the command to connected equipment (step **1558**).

[**0115**] In some embodiments, thermostat **600** may detect that no users have been associated, and may display a prompt on display **802** or on device **1502** with a tutorial on how to set up thermostat **600**. For example, if thermostat **600** has just been installed and has no associated users and detects Jill’s phone, thermostat **600** may display a message on Jill’s phone asking whether she would like a tutorial of

how to set up thermostat **600**, or if she would like a walkthrough of any of the features of thermostat **600**.

[0116] In multiple occupancy homes, thermostat **600** may allow multiple users. In some embodiments, a user may designate themselves as the master user, and may be able to override all commands to thermostat **600** from other users. In some embodiments, a new master user may be designated through an NFC check in based on the identifying information received by thermostat **600**. For example, master user Jill may leave for work early in the morning while Jack remains at home until the afternoon. Jack may be able to check in and become the new master.

[0117] In some embodiments, thermostat **600** may automatically execute commands communicated through NFC. Users may be able to queue commands to thermostat **600** on their electronic device and transmit them through the use of NFC. In some embodiments, a user may send commands directly through user interface **612**. In other embodiments, a user may send commands through electronic device **1502**. For example, an application made by Johnson Controls Inc. for interacting with thermostat **600** may be available for download to a user's device. In some embodiments, if a user has not downloaded the application, thermostat **600** may be able to detect this and activate a prompt which asks the user if they would like to install the application. Thermostat **600** may be able to communicate with the network and initiate the installation process for the application. In other embodiments, a web-based application may be available for use with thermostat **600**. For example, Johnson Controls Inc. may create an application which users can access from any device with network connectivity.

[0118] In FIG. 16A, thermostat **600** is communicating with network **1602** to receive information which thermostat **600** then transmits to device **1502**. In some embodiments, network **1602** is a cloud storage service. In other embodiments, network **1602** may be a LAN or any other type of network, and may allow access to the Internet.

[0119] Referring now to FIG. 16B, thermostat **600** communicates over NFC with device **1502** which communicates with the network. Thermostat **600** may command device **1502** to retrieve information from network **1602** instead of transmitting the data over NFC. This embodiment and the previous embodiment are critically different in the flow of information.

[0120] Thermostat **600** may be able to receive billing information from device **1502**. A user may wish to analyze their usage and their bill to make decisions regarding their behavior moving forward. In some embodiments, a user may be able to bring device **1502** within range of thermostat **600** and transmit bill information to thermostat **600**. In some embodiments, the information is transferred over NFC after authentication of the user and device **1502**. In other embodiments, the user and device **1502** are authenticated over NFC, and a command is sent to thermostat **600** to retrieve bill information from the network. The information retrieved may be in the form of Excel data, an XML file, a .txt file, any file type with tags, or any number of data formats. A user may be able to pay their bill over NFC through protocols such as Android Pay or Samsung Pay.

[0121] In FIG. 17, process **1700** is an exemplary method through which thermostat **600** may preprocess stored data in order to send performance reports to device **1502** almost instantaneously. In some embodiments, device **1502** is able to quickly pull raw data via NFC from thermostat **600** to

generate performance reports on topics such as energy management. Thermostat **600** may store data within a memory integrated with the device itself. In some embodiments, thermostat **600** may store data in the network. In step **1702**, thermostat **600** prepares reports for download by device **1502** in advance of a request for a report. Device **1502** checks in over NFC with thermostat **600** and is authenticated (step **1704**). Once device **1502** is authorized to download reports from thermostat **600**, the analytics are downloaded for immediate display in step **1706**. The entire process is streamlined to provide users with quick updates of their system performance. In some embodiments, generated reports pertain to energy management. In other embodiments, reports pertain to system operating parameters and performance metrics such as time-to-setpoint. In some embodiments, reports may be sent to a different authorized device after check in and specification by the user. The state and operation parameters of an HVAC system are constantly changing. In some embodiments, placing device **1502** on thermostat **600** provides a user with a snapshot of the system which includes information such as the system state, setpoint, current temperature.

[0122] Referring now to FIG. 18, the process of locking thermostat **600** over NFC is shown. A user (in this exemplary process, Jill) may check in with thermostat **600** with device **1802** and send the command to lock operation. Thermostat **600** receives the command and locks operation until another command is received. All attempts to input commands from other users (device **1806**), pets, or small children (baby **1804**) will be denied. Upon check in from the same user's device, cellphone **1802**, which locked thermostat **600** and receiving the unlock command, thermostat **600** may resume operation and become receptive to commands from other users. In some embodiments, thermostat **600** may be commanded to allow other authorized users who check in to unlock operation. For example, Jill could send a command authorizing Jack to unlock operation—no one but Jack and Jill can unlock thermostat **600**. In other embodiments, a user may be able to lock thermostat **600**, but a master user may be able to unlock thermostat **600** without specifically being authorized to do so. For example, Jack may lock thermostat **600** without designating anyone else as an authorized user; because Jill is a master user, Jill can unlock thermostat **600**. In some embodiments, a user may have more than one device associated with him and thermostat **600** may recognize all devices and allow him to lock and unlock devices with different devices associated with him.

[0123] Referring now to FIG. 19, an exemplary process **1900** for changing zones based on the user is shown. It is contemplated that there are multiple conditioning zones in a home, and that an NFC tag or sensor may be installed in each. Depending on the zone in which a user checks in, thermostat **600** may automatically receive commands to adjust settings for that zone. Jack, a user is shown checking in with an NFC tag on the first floor, or zone **1**, of his home in step **1092**. Once Jack's device **1502** is authenticated, thermostat **600** receives an automatic command to adjust settings of zone **1** to Jack's preferences in step **1904**. Jack is then shown to check in on the second floor of his home in step **1906**. Once Jack's device **1502** is authenticated, thermostat **600** receives an automatic command to adjust settings of zone **2** to Jack's preferences in step **1908**. In a multiple occupancy home, thermostat **600** may support multiple settings for each zone. In some embodiments,

thermostat **600** may adjust each zone to a different user's preferences. In other embodiments, thermostat **600** may decide that zones in which a user has not checked in are not occupied, and therefore adjust or reduce conditioning in those zones. A user may be able to save preferred zones as part of their settings. For example, if a home is divided into zones such that there is one zone for each room, a user may save their bedroom as their preferred zone. Upon check in at any of the NFC sensors in the home, settings for their preferred zone will be communicated to thermostat **600**, which will control the appropriate connected equipment.

[0124] Referring now to FIG. 20, an exemplary process **2000** for adjusting conditioning when a user is between zones is shown. In many homes, the only thermocouples or other temperature sensors are the ones integrated with the thermostats. In step **2002**, thermostat **600** may detect that a user is not in just one zone. Thermostat **600** sends a prompt to be displayed on user's device **1502** which asks whether it is cool enough. If the user feels that it is not cool enough, despite the thermostat's sensor reporting that the desired temperature has been reached, he may choose to say "No." Thermostat **600** then adjusts the operating conditions of one of the zones the user is between. Once the conditions have stabilized, thermostat **600** sends another prompt to be displayed on user's device **1502** which asks whether it is cool enough (step **2004**). If the user still feels that it is not cool enough, in step **2006**, thermostat **600** adjusts the operating conditions of another zone the user is between. Thermostat **600** repeats this process until the user responds in the affirmative. This process could be used for heating, for adjusting humidity, etc. and is not limited to cooling.

[0125] Referring now to FIG. 21, thermostat **600** may be able to detect faults in or receive messages reporting faults from connected equipment. When a fault is detected, thermostat **600** may alert users by sending a prompt to the users' devices. For example, if a compressor is not functioning correctly and this malfunction is detected, thermostat **600** may send a prompt to device **1502** notifying the user that the compressor is not performing as expected. In some embodiments, thermostat **600** may contain contact information for the dealer or an authorized repair company. Thermostat **600** may include the contact information in the prompt, or provide it when a user indicates that they would like to call for help. For example, thermostat **600** may ask a user if they would like to contact the dealer, and offer to dial the dealer's number if a user chooses to accept. In some embodiments, thermostat **600** uses NFC to send the dealer's number to the user's phone when the user places his phone on thermostat **600**. In some embodiments, thermostat **600** may generate an estimate for repair costs based on historic data. In other embodiments, thermostat **600** may receive communication from the dealer with an estimate of the repair based on the information transmitted.

[0126] Thermostat **600** may be able to provide different user interfaces and make different options available depending on the user. As shown in FIG. 22A, thermostat **600** may have an operating mode targeted to dealers which allows for configuration of thermostat **600** before purchase by the end user. A technician is shown to use dealer authorized device **2202**. In some embodiments, thermostat **600** in dealer mode will allow a dealer to apply a custom configuration specific to their dealership. The dealer may program in their contact information to be displayed when a fault is detected. The dealer may choose to include their logo, custom messages,

and specific settings for system parameters. The dealer may configure any aspect of the thermostat. In some embodiments, the dealer may contact the customer before purchase and configure the settings to the customer's specifications. The dealer may be able to include fault suppression rules, such that minor faults are not displayed to the user to prevent undue concern. For example, faults related to energy efficiency may not be displayed to the user. In some embodiments, the dealer may be able to demote faults to prompts such that a user remains informed, but does not become distressed. For example, if a user's AC unit is not functioning as efficiently as it could, the dealer may demote the fault to a prompt which notifies the user that current outside conditions make it difficult to operate at maximum efficiency. In some embodiments, dealers may edit the language of the faults. For example, if a catastrophic failure of the system occurs, a dealer may change the language of the fault notification to a less panic inducing message.

[0127] Referring now to FIG. 22B, thermostat **600** may follow different procedures for reporting faults when a dealer is the user checked in. Information may be transmitted to the dealer or repairman over NFC. In some embodiments, the information itself is not sent—instead, a key or command is sent to the device to retrieve the information from the network. In some embodiments, thermostat **600** is able to send the dealer or repairman to the appropriate troubleshooting page for the specific model of equipment being worked on. Troubleshooting techniques and common problems and their solutions may be displayed. In some embodiments, thermostat **600** may communicate where variations in the system and most commonly identified trouble junctions are during installation. Thermostat **600** may store performance data and fault data. In some embodiments, this data is stored in memory integrated with thermostat **600**. In other embodiments, this data is stored in the network and accessed by thermostat **600** when needed. Thermostat **600** may be able to produce a system performance history report. In some embodiments, thermostat **600** may produce a fault history report or any number of analytic reports on the operation of the system.

[0128] Referring now to FIG. 23, equipment connected to thermostat **600** may include RFID tags which can be scanned by thermostat **600** or the device of an installer. AC unit **2302** and furnace **2304** are shown to include RFID tags. The RFID tags may contain identifying information such as the serial number, model, and install date. For ease of installation, the RFID tags may link to installation instructions unique to the model of equipment being installed. In some embodiments, other information such as wiring diagrams and set-up guides may be available upon scanning the RFID tag of the respective piece of equipment. Thermostat **600** may send a key to access the information over NFC along with a command to retrieve the information from the network. The information may be displayed on dealer authorized device **2202** or another authorized device. In some embodiments, the information may be displayed on display **802** of thermostat **600**. In some embodiments, dealers may be able to input the warranty information for the system to be made available to the user if requested from thermostat **600**. In some embodiments, the warranty information and period may be automatically applied during installation via NFC. In some embodiments, a user is able to retrieve warranty information from thermostat **600** via NFC by placing device **1502** on thermostat **600**.

[0129] It should be noted that some or all of the features disclosed above described with respect to advanced functions and modes available to dealers and installers may also be available to end users, if desired.

Smart Thermostat and Equipment Communications

[0130] Most commercial thermostats available to consumers are only capable of uni-directional communication: switching on or off connected equipment. Thermostat **600** is capable of bi-directional communication with connected equipment in the system. Referring to FIG. **24**, it is shown that thermostat **600** is capable of communicating with a variety of devices, such as light system **2404**, refrigerator **2406**, security system **2408**, blinds or windows **2410**, door **2412**, or fitness tracker or other wearable **2414**, either directly or through an intermediary. Thermostat **600** may communicate directly with connected HVAC equipment **2420**. Thermostat **600** may communicate with services such as weather service **2416**, utility provider **2418**, network **2422**, or server **2424**. In some embodiments, thermostat **600** communicates with devices through router **2402** to which the devices are connected. In other embodiments, thermostat **600** communicates with devices through network **2422** with which the devices are connected. User owned portable electronic devices with which thermostat **600** may communicate include device **1502**, laptop **2426**, or tablet **2428**. It is understood that the resources with which thermostat **600** is shown to be connected are not meant to be limiting, and that thermostat **600** may be connected with any number of devices, services, and systems. Communication may occur over any of a number of protocols: communication may occur over wired or wireless venues. Communication may occur over WiFi, Bluetooth, LAN, TCP/IP, etc.

[0131] Referring now to FIG. **25**, thermostat **600** is able to receive information used to calculate metrics such as assumed load and current energy consumption due to its bi-directional communication abilities. Thermostat **600** is shown to be connected with network **2422**, through which thermostat **600** may communicate with dealer **2502**, weather service **2416**, analytics service **2504**, or utility provider **2418**. Thermostat **600** is shown to be communicating directly with HVAC equipment **2420**. It is understood that the resources with which thermostat **600** is shown to be connected are not meant to be limiting, and that thermostat **600** may be connected with any number of devices, services, and systems. The history of the system, including equipment operating performance, can be stored either in memory integrated with thermostat **600** or in network **2422** for later access.

[0132] Thermostat **600** may analyze the data through analytics service **2504**. Analytics service **2504** may be an embodiment of analyzer **712** of memory **704**, which is integrated with thermostat **600**, or may be a remote module able to communicate with thermostat **600** in any of the ways in which thermostat **600** is able to communicate: through wired or wireless protocols. Thermostat **600** and analytics service **2504** may be able to use historical data from the system with which it is associated as well as other systems connected to the network which are similar in size and equipment configuration. Thermostat **600** may be able to use local equipment history or history stored in network **2422** of similar equipment to educate a user on the capabilities of his system. Analytics service **2504** may have algorithms available to it, as well as a store of historical calculations and

analysis from which it may provide informed estimates. Thermostat **600** may receive basic operational data from connected equipment which it then transmits to analytics service **2504**. Analytics service **2504** may use feedback from connected equipment to make accurate estimates and to detect faults. For example, analytics service **2504** may determine that despite the AC unit operating at maximum settings for the past 20 minutes, no change in temperature has been detected. Analytics service **2504** may then generate an error message for thermostat **600** to communicate to a user. Analytics service **2504** may also be able to detect problems such as capacity incongruences and staging malfunctions. It is understood that analytics service **2504** is not limited to detecting problems explicitly enumerated.

[0133] Thermostat **600** may connect with a commercial energy management software which provides tools to users. These tools may allow users to create reports using variables in which they are interested. In some embodiments, thermostat **600** may transmit all data received to the commercial energy management software for processing and presentation to a user. Thermostat **600** may receive results and reports from the energy management software for display to a user on a portable device or on display **802**. In some embodiments, thermostat **600** may generate the results and reports and display the results and reports to the user on portable device **1502** or on display **802**. Advantages of not processing data locally include reduced cost of units for consumers and simplicity of updating or patching functionality. Thermostat **600** may be compatible with a plug in which communicates with thermostat **600** and a standalone program. The plug in may detect parameters such as current draw, and may be able to detect actions of the system early through monitoring current draw or other such parameters.

[0134] Analytics service **2504** may combine a user's energy usage data with their energy bill to report on the fiscal effects of a user's behavior. Thermostat **600** is able to communicate with a user's device which may authorize thermostat **600** to receive billing information. In some embodiments, thermostat **600** may help a user reduce their energy bill by integrating demand-response information into the report. In some embodiments, thermostat **600** is able to develop a cost analysis of a user's energy behavior. For example, thermostat **600** may be able to receive demand-response feedback from a utility provider or smart meter which can be analyzed along with a user's energy usage to inform the user of the effects of their usage behavior.

[0135] Referring now to FIG. **26B**, several processes through which a user can control her energy usage and resulting energy bill are shown. In process **2602**, display **802** of thermostat **600** is shown. Thermostat **600** may suggest setpoints to help a user reach her target bill amount. In step **2604**, a user is asked to input her current monthly energy bill and their current setpoints. For example, Jill may currently be paying \$350 a month in energy bills by keeping her setpoints at 68° F. in the summer and 76° F. in the winter. In step **2606**, the user is asked to input her target bill amount. Jill may wish to reduce her bill to \$250 a month. In some situations, the target bill amount is not possible. Thermostat **600** may display a warning to the user that her target is unachievable under the current operating conditions. For example, it is the coldest winter in Jill's area in 100 years. In order to keep temperatures at a livable level and prevent damage to the plumbing, the temperature needs to be kept at or above 65° F. In another situation, it is the hottest summer

in Jill's area in 100 years. The units in Jill's home are not equipped to efficiently cool a house of that size to a livable temperature. Thermostat 600 is unable to save enough energy to reduce Jill's monthly bill to \$250 and when she inputs her target payment as \$250, thermostat 600 may flash a message which reads "Current operating temperatures prevent me from reaching your target bill amount. We are on track to having a bill of \$300 this month." When the target bill amount is possible, thermostat 600 may change the setpoints to the setpoints suggested to the user. In one embodiment, a user may input her own preferred setpoints to see what her monthly bill may be if she does not make changes to her energy usage. In step 2608, for example, Jill may input her preference for 70° F. and 74° F. Thermostat 600 may determine that based on local historical equipment data, Jill's monthly bill with her current settings will be \$230. In some embodiments, thermostat 600 may use data from the history stored in network 2422. Thermostat 600 may communicate the need to have the data analyzed by data analytics service 2504. Thermostat 600 may communicate with other devices connected to network 2422 and display information on connected devices. In some embodiments, thermostat 600 may display all data and communications on a user device 1502.

[0136] Still referring to FIG. 26B, in process 2624, thermostat 600 may allow a user to track their usage relative to their target. In step 2626, thermostat 600 shows on display 802 a user's energy usage relative to their goal payment for the month. For example, Jill would like to pay \$100 for the month of July. It is the 13th, and she is already halfway through her target payment. This allows Jill to make an informed decision on whether she would like to adjust her usage habits or receive a larger bill. In some embodiments, thermostat 600 may provide a report of different operating parameters and their respective energy usage. In step 2628, the runtime of each stage of the compressor is shown. In step 2630, the calculated cost associated with the runtimes of each stage is shown. This comparison informs users of their usage habits and allows users to decide whether and how to make adjustments to affect their monthly bill. In some embodiments, thermostat 600 may use data from the history stored in network 2422. Thermostat 600 may communicate the need to have the data analyzed by data analytics service 2504. Thermostat 600 may communicate with other devices connected to network 2422 and display information on connected devices. In some embodiments, thermostat 600 may display all data and communications on a user device 1502.

[0137] Still referring to FIG. 26B, thermostat 600 may make changes to setpoints automatically (process 2650). In step 2652, display 802 of thermostat 600 is shown to inform a user that his setpoint has been raised by 2° F. For example, Jack may have had his setting at 72° F. and over the course of a few hours, thermostat 600 may have raised the temperature to 74° F. Thermostat 600 may inform Jack that his setpoint was increased, and ask whether he had noticed a difference in comfort or whether he would like to keep the change made. If a user chooses to accept the change, thermostat 600 may display the projected savings resulting from the change (step 2654). In some embodiments, this is a monthly savings. Thermostat 600 may be able to estimate the savings for just one day, or for a year. This feature may help users save energy by making adjustments and showing them how even a small change can result in savings. In some

embodiments, thermostat 600 may use data from the history stored in network 2422. Thermostat 600 may communicate the need to have the data analyzed by data analytics service 2504. Thermostat 600 may communicate with other devices connected to network 2422 and display information on connected devices. In some embodiments, thermostat 600 may display all data and communications on a user device 1502.

[0138] Still referring to FIG. 26B, thermostat 600 may compare a home's system with systems in the surrounding area or neighborhood (process 2674). In some embodiments, thermostat 600 receives information regarding the systems in the surrounding area from data analytics service 2504. In some embodiments, only homes with similar settings and equipment will be shown. In other embodiments, all homes will be shown regardless. In step 2676, thermostat 600 may show on display 802 statistics on setpoints being used by neighbors. This allows users to compare their usage habits with users in similar environmental conditions. For example, Jack and Jill live in Mr. Roger's Neighborhood. Thermostat 600 shows that 40% of homes have setpoints at 72° F. and 72° F. (meaning that they keep 72° F. as the setpoint year round). In step 2678, thermostat 600 may show the average monthly bill for the set of homes included in the report. Thermostat 600 may ask users if they would like to try the settings, allowing users to make budget and energy conscious decisions without undue effort. In some embodiments, thermostat 600 may use data from the history stored in network 2422. Thermostat 600 may communicate the need to have the data analyzed by data analytics service 2504. Thermostat 600 may communicate with other devices connected to network 2422 and display information on connected devices. In some embodiments, thermostat 600 may display all data and communications on a user device 1502.

[0139] Thermostat 600 may make comparisons of the connected system to similar systems connected to the network. System analyzer 714 may find a subset of systems connected to the network which are similar to the system connected to thermostat 600. Similar systems may be determined based on equipment configurations, size of home, location, climate, and various other factors or any combination of the previously mentioned factors. Thermostat 600 may send a request for a report to be generated by analytics service 2504, which may retrieve data, from the subset of similar systems determined by system analyzer 714, from the network. Reports may be generated which analyze energy usage of the occupants of a home. As shown in FIG. 26A, thermostat 600 may display reports on a user's device 1502 to compare and contrast a user's energy consumption and behavior with other similar systems. Thermostat 600 may also show comparison reports on display 802. For example, thermostat 600 may display reports comparing John's usage with his neighbors—Jack and Jill's—usage.

[0140] In other embodiments, thermostat 600 may find systems which are similar with respect to many parameters, although not necessarily geographically close. Thermostat 600 may be able to notify a user of their ranking in terms of energy usage. For example, thermostat 600 may inform a user that their energy usage is above average among similar systems. This allows users to evaluate their energy usage behavior and decide whether they value efficiency, comfort, or a compromise. In some embodiments, number ranks could be given, encouraging users to experiment with ther-

mostat 600 and its settings in order to be more efficient. It is contemplated that users can post their rank and their settings on social media to share with others and to create a sense of competition. For example, a user may post their settings on a social media web site with the message “My conditioning system is running 10% more efficiently this month and saved \$15 on my electricity bill! Thanks Johnson Controls Inc.!”

[0141] Referring now to FIG. 26C, users may be able to indicate their preference to thermostat 600, which may use the preference to make operation decisions. When comparing systems according to process 2680, thermostat 600 may determine whether settings of other systems can impact a user’s energy usage. In step 2681, system analyzer 714 may find a subset of systems connected to the network which are similar to the system connected to thermostat 600. Similar systems may be determined based on equipment configurations, size of home, location, climate, and various other factors or any combination of the previously mentioned factors. Thermostat 600 may find that a neighboring home of a similar size with a similar system is using much less energy (step 2682). If the user has indicated that they value energy efficiency, thermostat 600 may notify the user that potentially more efficient settings have been found (step 2683). In some embodiments, thermostat 600 may automatically test-run settings which have been identified as potentially impacting a user’s energy usage. For example, thermostat 600 may run settings of a potentially more efficient system while a user is not home and report the results of the test when the user returns (step 2684).

[0142] In some embodiments, thermostat 600 may display a prompt with the identified potentially impactful settings and allow a user to decide which settings to test. For example: a system identical in equipment and area serviced is identified as operating 10% more efficiently than Jill’s system. Thermostat 600 may display “According to information stored in the cloud, you may be able to increase efficiency by increasing your fan speed to HIGH. Would you like to increase your fan speed from MEDIUM to HIGH? To accept this change, please select Yes. To reject this change, please select No.” Depending on Jill’s selection, thermostat 600 would either adjust fan speed or dismiss the prompt. In some embodiments, an issue may occur when a setting does not produce expected results. For example, the blower of a system is too small to operate any more efficiently at higher speeds. A compressor may be broken and consequently produces no better results when staging is altered. Thermostat 600 may identify the source of these issues and evaluate what the problem is (step 2685). Thermostat 600 may then display a prompt to the user asking whether she would like to call her dealer or a technician to repair the identified source of the problem (step 2686). For example, if a furnace is connected to thermostat 600, thermostat 600 can communicate with the furnace and determine that there is a problem with the airflow of the furnace. Thermostat 600 can use information gathered from the furnace to identify that an air filter of the furnace needs to be changed. Thermostat 600 can then display a prompt to the user identifying the issue as a bad air filter. In some embodiments, the information regarding identified problems are sent directly to the user and the technician via an email or text message.

[0143] Thermostat 600 is able to provide a clear and up-to-date report of a home’s energy usage. Thermostat 600 is able to communicate with a wide variety of devices, and the communication allows greater detail when creating a

usage report. Whereas a monthly bill from a utility provider merely shows the total usage, analytics service 2504 offers key information such as the time of use and the piece of equipment associated with the usage. For example, thermostat 600 may display an energy usage report which shows that for the past two days, the dishwasher has been using more than twice the amount of energy it has been using for the three years it has been in the home. Thermostat 600 may detect the discrepancy and notify a user that the dishwasher may be malfunctioning. Thermostat 600 may display an energy report which shows that the AC system is using less energy than a user had previously thought. Thermostat 600 may display an energy report that shows that the washing machine is using energy even when it is not being used. This information may help a user decide that it is time to replace old, inefficient appliances. Thermostat 600 may connect to older, existing equipment in a home to improve efficiency over previous performance using a conventional thermostat. In some embodiments, thermostat 600 applies changes to the equipment operating parameters using metering over time.

[0144] Thermostat 600 may be able to use analytics service 2504 to calculate the time needed to reach the setpoint commanded by the user. In some embodiments, this calculation is done locally. In other embodiments, thermostat 600 may transmit the data to analytics service 2504 which may transmit the results back to thermostat 600 or a user device 1502 for display. For example, thermostat 600 may receive a command to condition a home to 72° F. when the outside temperature is 80° F. and there is low humidity. Thermostat 600 transmits the current operating conditions and the command to analytics service 2504. Analytics service 2504 determines, from current operation conditions, feedback from the equipment, and historical data, that the system will be able to reach the setpoint specified in half an hour. Analytics service 2504 transmits this information to thermostat 600, which then displays a message to the user notifying her that the system will reach the setpoint in half an hour. In some embodiments, based on certain outside conditions, the system may be under an unusual amount of load. Analytics service 2504 may recognize this when comparing system performance with similar systems and adjust the time estimate. In some embodiments, analytics service 2504 may add an offset to the standard time estimate. It is contemplated that analytics service 2504 is able to perform this function for more optimal conditions as well, and subtract an offset from the standard time estimate.

[0145] Referring now to FIG. 26D, thermostat 600 may be able to notify a user of the ability of the system to reach the setpoint specified by the user. For example, thermostat 600 may receive a command to condition a large home to 77° F. when the outside temperature is 105° F. Thermostat 600 sends the current operating conditions and the command to analytics service 2504. Analytics service 2504 may determine, from current operation conditions, feedback from the equipment, and historical data, that due to the high humidity and the size of the AC unit installed relative to the size of the home, the system is unable to reach the setpoint. Analytics service 2504 may determine this by using data points from current operation to extrapolate future temperatures. Analytics service 2504 may use historical data points to determine setpoint limits under the current operating conditions. Analytics service 2504 transmits this information to thermostat 600, which then displays a message to the user notifying her that the system is unable to reach a setpoint.

[0146] When this situation arises, thermostat **600** may be able to notify the user in any number of different ways. Thermostat **600** may display an indicator such as a flashing message on display **802**, transmit a message to user device **1502** to vibrate and alert the user that the setpoint is unattainable, play a sound, or any number of other methods of notifying the user. Thermostat **600** may display a message with more information about the situation, such as the factors contributing to the inability of the system to reach the setpoint. It is contemplated that thermostat **600** may notify users of any condition and provide additional information, and that this feature is not limited to when the system cannot reach the specified setpoint. In some embodiments, thermostat **600** may be able to calculate the maximum or minimum setpoint which can be achieved based on the current operating conditions, feedback from equipment, and historical performance data. In some embodiments, thermostat **600** uses historical data to determine that a system was previously able to reach a setpoint, but is now unable to do so. In some embodiments, thermostat **600** monitors the time it takes the system to reach a setpoint and compares it to a threshold time. For example, if a system that historically takes 15 minutes to reach 65 degrees Fahrenheit when the temperature is 70 degrees Fahrenheit takes 30 minutes to reach 65 degrees Fahrenheit, the thermostat **600** can identify a decrease in performance. In some embodiments, thermostat **600** determines a new setpoint such that the time required to reach the setpoint is equal or less than the threshold time. In some embodiments, thermostat **600** may advance a time of a setpoint change to allow for the increased time required to reach the setpoint and enable the setpoint to be reached at the desired time. This decrease in performance may be due to degradation of components in the system, and thermostat **600** may display a prompt telling the user that a piece of equipment may be broken or damaged. Thermostat **600** may ask a user if they would like to call their dealer or a technician to have the system repaired. In some embodiments, thermostat **600** does not reach the setpoint due to weather conditions and operating limitations of the equipment. In some embodiments, thermostat **600** serves a notification to the user that the setpoint is unattainable.

[0147] Thermostat **600** may be able to offer an alternative when the setpoint cannot be reached. In some embodiments, analytics service **2504** may be able to find a solution in which the system can sacrifice certain parameters in order to achieve the user's desired setting. For example, thermostat **600** may be able to achieve the specified setting, if the user is willing to pay more in electricity, decrease the lifespan of components, wait for a longer period of time, or turn off another appliance. It is understood that there are other tradeoffs which could be made to achieve a desired thermostat setting. The choice is offered to the user, who will then be able to decide between energy saved and time lost.

[0148] Thermostat **600** may display the appropriate setpoint limit depending on whether a user is decreasing the setpoint (the minimum) or increasing the setpoint (the maximum). In some embodiments, thermostat **600** is able to detect when to show the setpoint limit, depending on the user's commands. For example, if a user is repeatedly inputting commands at user interface **612** of thermostat **600**, thermostat **600** may display the setpoint limit. In other embodiments, thermostat **600** may go directly to the limit after predetermined conditions have been met. For example, if a

user is inputting commands at user interface **612** of thermostat **600** and holds down a button for a certain amount of time, thermostat **600** may interpret the input as a command to set the system to the respective limit. In some embodiments, if a system is already at its limit when a user tries to command the system to move farther in the direction of the extreme, thermostat **600** may display a notification on display **802** to inform the user that the system is already at its limit, and that their request cannot be fulfilled under the current conditions.

[0149] Thermostat **600** may be able to show a user the efficiency or comfort consequences of their commands. Thermostat **600** may receive a command on a hot day to condition a home to 2° F. lower than it currently is. Thermostat **600** may transmit the current operating conditions and the command to analytics service **2504**. Analytics service **2504** may determine, from current operation conditions, feedback from the equipment, and historical data, the additional costs associated with the 2° F. decrease as well as the additional energy used based on billing history associated with the home, billing data of similar systems connected to the network, and algorithms for determining energy consumption. Thermostat **600** may be able to perform these calculations for any increase, decrease, or lack of change in the setpoint. The calculated energy consumption and additional costs may be used by analytics service **2504** to provide suggestions to users about their usage behavior. For example, thermostat **600** may display a message explaining that turning up the setpoint on a hot day by 2° F. may save a user as much as \$3.00 that day. Thermostat **600** may provide tips for conserving energy such as reducing load by turning off high-energy devices such as dryers, or by better insulating the home by closing windows. Thermostat **600** may provide suggestions of energy or money saving features not recently used.

[0150] Analytics service **2504** may be able to determine from comparing current performance with historical performance whether a piece of equipment is functioning correctly. For example, analytics service **2504** may determine that if a connected unit is malfunctioning, analytics service **2504** may transmit an error code to thermostat **600**, which then displays an error code to the user. In some embodiments, thermostat **600** may display the error code on display **802**. In other embodiments, thermostat **600** may display the error code on a user's device **1502** or in a web-based application connected to the system.

[0151] If a fault is detected, standard staging progressions or operating procedures may be altered to provide the best experience for the user. For example, an AC unit may normally transition from stage to stage without skipping stages. If thermostat **600** has detected that a fault has occurred somewhere within the system, thermostat **600** may command the compressor to skip the lower stages and go straight to the upper stages in order to maintain performance. In another example, thermostat **600** may receive information from the flow system that a pipe has been clogged somewhere in the system, and that airflow has been greatly diminished. In order to maintain performance, thermostat **600** may command an increase in airflow to compensate for the blockage.

[0152] Thermostat **600** may alter staging, airflow, or other system parameters based on historical performance. In some embodiments, analytics service **2504** may search through historical data to find periods of operation which match

conditions and select the settings and commands which produced the most desirable result according to the user's preferences.

[0153] Thermostat 600 may alter staging progressions or other operating parameters based on other factors, such as weather conditions and forecasts. Thermostat 600 may be able to receive weather information from a weather service, the network, or a device with which thermostat 600 can directly or indirectly communicate. In some embodiments, thermostat 600 is able to receive a weather forecast and make operating decisions based on that forecast. For example, thermostat 600 may receive information one balmy night that the next morning will be below freezing. Thermostat 600 may command the system to go to 100% operating power without transitioning through lower stages. In some embodiments, thermostat 600 may change the setpoint from the user defined setpoint using the weather information received.

[0154] Thermostat 600 may alter staging progressions or other operating parameters based on factors such as user demand or level of activity. In some embodiments, thermostat 600 adjusts operating parameters when a user commands a sudden and significant change in temperature. For example: it is below freezing outside and a user has returned home after vacation; the HVAC system is suddenly powered on and commanded to heat the home to 72° F.; thermostat 600 commands all equipment to operate at maximum capacity in order to reach the setpoint as soon as possible. In other embodiments, thermostat 600 detects the level of occupancy and activity, and adjusts operating parameters accordingly. For example: there is a party in the home and there are many people dancing; thermostat 600 detects the high level of occupancy and activity and commands all equipment to operate at maximum capacity in order to maintain the setpoint. It is understood that thermostat 600 may detect that there is low or no occupancy or activity and adjust operating conditions accordingly. For example, thermostat 600 may detect that there is little activity and command equipment to operate at low capacity and as efficiently as possible. In some embodiments, thermostat 600 may detect that there is no occupancy and that the outside conditions are acceptable and turn off all equipment in order to save energy.

Thermostat UI Features, Integration, Branding, and Social Media

UI Features

[0155] Referring again to FIG. 8, thermostat 600 is shown to have a display 802, and a frame 804. Display 802 and frame 804 may both be touch-sensitive, and accept user input as commands to thermostat 600.

[0156] Referring now to FIG. 27, a variety of ways to provide input to thermostat 600 are shown. Buttons 2702, 2704, 2706, and 2708 may be embodiments of buttons 806-812. Buttons 2704 and 2708 are shown in dashed outlines to clarify that they are not visible or physical buttons. Buttons 2702 and 2706 are shown in solid outlines, and are an exemplary embodiment of buttons printed on and defined by a physical skin. In some embodiments, hidden buttons are placed around frame 804. Having the option of providing input through the frame allows users to control thermostat 600 without obscuring display 802. In some embodiments, users are able to provide a direct touch to buttons 2704 and 2708 in the form of a button push. In some

embodiments, users are able to provide input in the form of gestures on frame 804. For example, a user may be able to swipe up or down to scroll, or left or right to move through screens. Input method 2712 is an exemplary method of interaction with the touch-sensitive buttons on frame 804. Thermostat 600 may recognize voice commands. Input method 2714 is an exemplary method of interacting with thermostat 600 via voice commands. Thermostat 600 may recognize input through the use of sensors 602-606. One of sensors 602-606 may be a camera, an IR sensor, a microphone, a capacitive sensor, or any other conceivable sensor. In some embodiments, sensors 602-606 are embodied as a microphone and voice recognition module 716 of memory 704 processes input locally. In other embodiments, the voice input may be sent to network 2422 and processed by a separate module. In some embodiments, a user gives voice commands to their personal device 1502 which processes the input and transmits the command to thermostat 600. Thermostat 600 may be programmed with a specific voice command that will not be commonly or accidentally said to enter dealer or advanced mode. For example, the phrase "advanced dealer mode 23" may be said to enter dealer mode when making a house call.

[0157] Thermostat 600 may recognize gesture controls through the use of sensors 602-606. For example, a user may perform a certain gesture to indicate returning to the menu, increasing the temperature, decreasing the temperature, or locking thermostat 600. Many types of gestures of varying complexity may be accepted as input to thermostat 600. For example, a user may swipe up or down to scroll. In some embodiments, gesture input is processed locally by a memory module gesture processor. In other embodiments, gesture input is received by thermostat 600 and sent to a processor connected to the network. The command is then transmitted to thermostat 600. In some embodiments, a specific gesture may put thermostat 600 in dealer or advanced mode. For example, an uncommon gesture such as making two circles may be used by a dealer when making a house call to put thermostat 600 into dealer mode.

[0158] Users may add customizable skins to thermostat 600 to alter its functionality and appearance. Skins may be physical appliques similar to stickers, or they may be a certain selection of settings. In some embodiments, skins have buttons printed in various locations. In some embodiments, the buttons are circles, squares, arrows or any other shape. In some embodiments, the buttons are customized images such as a dealer logo. In some embodiments, the buttons are custom images selected by a user. Skins may transmit the location of these buttons relative to frame 804 such that a touch of the button on the skin will register as an input associated with that location on frame 804. Users can design their own skins with their preferred button placement to apply to thermostat 600. In some embodiments, users may use an application (web-based, mobile application, or otherwise) or user interface 612 of thermostat 600 to define button placement on the frame and generate a digital file of the customized skin. Users may be able to define the functionality of buttons on the frame. In some embodiments, user created skins may be printed out by sending the digital file of the customized skin to a dealer. In other embodiments, custom skins can be sent to the manufacturer (e.g., Johnson Controls Inc.) to be printed. Skins may be created and applied to thermostat 600 prior to delivery. In some embodiments, users may design their own skin for thermostat 600

at the time of ordering. For example, Jack may wish to purchase a thermostat **600** for their grandmother who cannot see very well and does not want to use every feature of thermostat **600**; he creates a skin with large, clearly printed buttons and simplified menus when ordering thermostat **600**. In other embodiments, skins are created for dealers and applied prior to sale. Dealer created skins may include a dealer's logo, custom button configurations, unique settings, and contact information. For example, a dealer may program their information in as the contact when a fault requiring repair occurs. In some embodiments, skins may include 3D features such as braille to assist a visually impaired user to interface with the device. One of the 3D features may indicate a command to the device to read at least some of the information displayed over the speaker.

[0159] Skins may easily be shared over social media. Users may post designs for physical skins as well as the actual configuration skin. In some embodiments, other users can select skins to try on their respective thermostat **600**. Users may share results of their detailed energy usage reports to foster a sense of competition and to encourage others to be conscious of their energy usage. For example, a user may post their new configuration skin with the message "Went up by 1 degree and saved \$5 this month! #1degreeatatime #jci #savingtheworld #fahrenheit #imperialsystem4ever."

[0160] Many screens are available within user interface **612** which allow the user to control and interact with thermostat **600**. In some embodiments, thermostat **600** is able to learn from user input and behavior. Thermostat **600** may store frequency of screen visits, and automatically open to the most viewed screen. Thermostat **600** may allow users to select their favorite screen to be displayed first whenever user interface **612** is viewed. Buttons **806-812** can be used to interact with display **802**. In some embodiments, editing the placement of the buttons and the set-up of the screens shown on display **802** can be done through an application on thermostat **600** or user device **1502**.

[0161] Referring now to FIG. **28**, an exemplary process **2800** of controlling thermostat **600** by sending it text messages is shown. Thermostat **600** may have its own unique number at which it can receive messages through the cellular network. In step **2802**, a user opens the messaging app of their cellphone and selects thermostat **600**. In step **2804**, a user sends thermostat **600** the message "72" and thermostat **600** acknowledges. Depending on the settings selected by the user, thermostat **600** will interpret the number received as either degrees Fahrenheit or degrees Celsius. In some embodiments, thermostat **600** will be able to detect, based on which user is sending the command, which units are being specified. Thermostat **600** may determine that the command received is either degrees Fahrenheit or degrees Celsius based on predetermined limits, as there is little chance that a user would like for their home to 25° F. or 72° C. In step **2806**, thermostat **600** adjusts operation in accordance with the target temperature received in the previous step. Thermostat **600** may receive commands from any source. It is contemplated that thermostat **600** may receive commands from an email, a phone call, a video message, a social media message, or any other form of communication.

[0162] Referring now to FIG. **29**, thermostat **600** may connect to social media to gather event data and adjust scheduling accordingly. Thermostat **600** may determine that a user will not be home because they will be at an event at

a location which is not home and reduce conditioning to operate more efficiently until it is anticipated that the user will return home. For example, a user may accept an invitation to a dinner at a restaurant from 1900 until 2200 one evening. Thermostat **600** may reduce conditioning at 1900 and, depending on the expected time to the setpoint at which the user left the home, may begin to increase conditioning an appropriate amount of time prior to 2200. In some embodiments, thermostat **600** may determine that an event is occurring at home and adjust scheduling and occupancy accordingly. For example, FIG. **29** shows that seven people are attending a hype club for Thermostat (possibly thermostat **600**) at Jack and Jill's house. Thermostat **600** determines that Jack and Jill's house is home, and that occupancy will be seven people on August 17th from 1630 to 2030. Thermostat **600** will adjust conditioning, scheduling, and occupancy on August 17th to accommodate the high occupancy and the scheduled event so that the home will be conditioned by the time the event starts. There are situations in which a user may wish to delay scheduled events or the programmed schedule for thermostat **600**. In some embodiments, thermostat **600** may communicate with a user's calendar application or clock application so that when the user chooses to "snooze", thermostat **600** will delay scheduling by the amount that the snooze is set for. For example, if thermostat **600** is scheduled to reduce heating when Jack is at work from 0900 until 1700 on a winter day, but Jack has a late morning meeting he would like to get more sleep for, he can hit snooze for 30 minutes in the alarm app on his phone and rest easy knowing that thermostat **600** will not suddenly leave him freezing while he is getting ready.

Integration of Other Systems/Cloud

[0163] As shown in FIG. **24**, thermostat **600** is capable of communicating with many devices. Thermostat **600** may receive data from various sensors around the home to use when making operating decisions. Thermostat **600** may be able to determine occupancy without the use of an integrated sensor if sensors in places such as windows and doors are installed and connected to thermostat **600** or the network. For example, thermostat **600** may determine that the home is occupied upon activation of the front door sensor and begin conditioning the home based on the master user's preferences. Thermostat **600** may detect that a window or door is open and display a message on display **802** or in some embodiments on device **1502** warning a user that a window or door is open and may cause an increase in energy consumption and a decrease in efficiency. Thermostat **600** may also determine that the home is no longer occupied upon a second activation of the front door sensor and begin reducing conditioning of the home. It is understood that more sophisticated algorithms for determining occupancy may be used to prevent issues such as a guest entering a home, letting a pet outside, or other such situations. Thermostat **600** may communicate with users' personal devices, such as cellphones, heartrate trackers, fitness trackers, or any of a variety of personal devices. In one embodiment, thermostat **600** may determine level of activity based on information from a user's heartrate or fitness tracker and adjust conditions accordingly.

[0164] In some embodiments, a user may interact with thermostat **600** via a mobile application and can select an override mode for thermostat **600**. The modes may be "Away", "Home", "Party", "Cooking/Baking", "Workout",

“Sleeping” “Housework”, a custom mode, and any other such mode for thermostat **600**. Each mode may be configured to adjust settings of thermostat **600** to account for the activity of a user. Each mode may have a setpoint and a time duration determined by the user. For example, a user may be going to sleep and may press the sleep button associated with the “Sleeping” mode on the mobile application. Thermostat **600** may receive command from the mobile application to enter the “Sleeping” mode. Thermostat **600** may change the setpoint to 65 degrees Fahrenheit for 8 hours. 65 degrees Fahrenheit may be the preferred sleeping temperature of the user. When a user makes changes to an operating mode or creates a new operating mode via the mobile application, the operating mode may be created and/or updated on the mobile application running on a mobile device, a server hosting information pertaining to the mobile application, and/or thermostat **600**.

[0165] In some embodiments, a fitness tracker may interface with the mobile application and may identify that the user associated with the fitness tracker is moving rapidly. Thermostat **600** may receive a command to enter “Workout” mode from the mobile application when the fitness tracker identifies rapid movement. In some embodiments, the mobile application is interfaced with a user calendar. The user may have calendar events scheduled on the calendar such as “Cleaning time”, “Half hour workout”, and/or “Birthday Party”. Thermostat **600** may receive a command from the mobile application to run a mode appropriate for each of the calendar events.

[0166] In some embodiments, thermostat **600** may be connected to thermal sensors. In some embodiments, thermal sensors are infrared temperature sensors. The thermal sensor may be located in different rooms of a building. Thermostat **600** may use information received from the thermal sensors to determine what rooms are occupied and/or unexpected temperature increases in a room. For example, thermal sensors may identify that an individual is exercising in Room A and thus lower the temperature setpoint in Room A to keep the individual exercising comfortable. In some embodiments, thermostat **600** may identify that a room in the building is much hotter than other rooms. For example, thermostat **600** may identify that Room B is warmer than Room A based on information received from the thermal sensors. Thermostat **600** may identify that there is a problem with HVAC equipment in Room B based on this comparison. In some embodiments, when thermostat **600** identifies an unexpected temperature increase, thermostat **600** tells a user to have thermostat **600** and/or HVAC equipment connected to thermostat **600** serviced. In some embodiments, thermostat **600** may give the user specific instructions through user interface **612** for improving the performance of thermostat **600** and/or the HVAC equipment connected to thermostat **600**. For example, the specific instructions may be changing air filters, checking for blocked duct pipes, closing windows or curtains in certain rooms, and/or any other method that can be used to prevent the HVAC system from becoming damaged and/or using excessive amounts of energy.

[0167] Thermostat **600** may have control over other systems in the home, such as the lighting system or the security system. In some embodiments, when occupancy is detected, thermostat **600** may turn on lights where a user is determined to be. For example, if Jill comes home, checks in, and proceeds to her bedroom, thermostat **600** may turn on the

lights on the way from the door to Jill’s bedroom. In other embodiments, thermostat **600** may be able to turn off lights when occupancy is no longer detected. Thermostat **600** may enable the security system when occupancy is no longer detected. For example, if Jack leaves for work but forgets to set the alarm, thermostat **600** may arm the security system after failing to detect occupancy in the entire home for 30 minutes. In some embodiments, thermostat **600** may be able to disarm the security system if occupancy is detected. For example, if Jill comes home and checks in, thermostat **600** may disarm the security system. It is understood that more sophisticated algorithms may be used to prevent issues associated with the turning on of lights in rooms where a user may be sleeping or enabling the alarm system while users are still home. Thermostat **600** may be able to control systems such as blinds, windows, and doors. Thermostat **600** may be able to draw blinds or close doors or windows when occupancy changes, or in order to improve efficiency or performance of the system.

[0168] Thermostat **600** may receive data from a weather service, as mentioned previously. In some embodiments, thermostat **600** may show the forecast on display **802**. Thermostat **600** may be able to send the forecast to a user’s phone on a schedule or upon check-in with thermostat **600**.

[0169] Thermostat **600** may communicate with commercial storage solutions such as Dropbox, Google Docs, or Amazon Cloud. Thermostat **600** may store data in such places in order to record trends and make data and analytic reports more accessible to users. Storing data in places other than local memory will also reduce the cost of thermostat **600** as a unit and promote sales.

[0170] Thermostat **600** may communicate with the network to receive firmware updates. In some embodiments, the firmware updates are for connected equipment. For example, thermostat **600** may receive a notification that the AC unit has an available firmware update. Thermostat **600** may show a prompt on display **802** with a message such as: “A firmware update is available for your AC unit. Would you like to call your dealer to schedule a home visit?”

[0171] Thermostat **600** may communicate with a user’s utility provider. System performance data may be integrated with utility data in order to monitor a home’s level of energy usage and inform users of their usage habits.

Branding

[0172] The appearance of thermostat **600** can easily be changed to a dealer or end user’s preference. This flexibility provides many opportunities for marketing and promotion of a brand. Dealers may choose to use custom branding in order to familiarize consumers with their business. Dealers may be provided with skin templates to choose from which will change the user interface or the physical appearance of thermostat **600**; these skin templates may be further customizable. For example, dealers may be presented with three or four skin templates for the user interface of thermostat **600**.

[0173] An application may allow a dealer to customize the color scheme of his chosen template. In some embodiments, this application is a stand-alone application to be accessed through a computing device such as a laptop or smartphone. In other embodiments, this application is a web-based application which may be accessed through any network connection. Dealers may be able to customize the fonts used in the user interface or on the physical skin. In some embodi-

ments, dealers may choose from a selection of chosen font pairs which go well together. In some embodiments, the skin created with such a branding design tool may be applied, prior to sale, to all thermostats a dealer sells. In some embodiments, the branding is dealer information. Dealer information may include a dealer phone number, a dealer address, dealer store hours, a dealer RSS feed, and a dealer logo. In some embodiments, thermostat 600 is branded at installation. In some embodiments, a skin template may be available which is tailored to meet the Americans with Disabilities Act (ADA) specifications. Color schemes, font size and choice and animations may be customized to meet ADA specifications. Features such as ADA compliant sounds or other feedback may be made available through the branding tool. Dealers may wish to use a more subtle method of branding; for example, using only the logo or icon without the brand name attached.

[0174] As shown in FIG. 22A, a dealer can program their contact information into thermostat 600 to be made available to an end user whenever service or advice is needed or maintenance is required. In some embodiments, the maintenance is needed for thermostat 600. In some embodiments, the maintenance is needed for equipment connected to thermostat 600. In some embodiments, the dealer can program the dealer's address and store hours into thermostat 600. In some embodiments, thermostat 600 includes a microphone and a speaker. Dealers may choose to customize a physical skin which will provide a button for a user to press which will call the dealer when pressed. The call may be placed as a Voice over Internet Protocol call. The call can utilize a microphone and speaker of thermostat 600. In some embodiments, thermostat 600 will communicate with the user's cellphone and automatically place the call.

[0175] In some embodiments, dealer information and/or dealer branding may be shown on user interface 612 of thermostat 600. The dealer branding may be displayed at a first rate such as twice an hour when the HVAC system is operating normally, and may be displayed at a second rate higher than the first rate, such as 12 times an hour (or continuously), when the HVAC system is not operating normally or optionally if a setpoint cannot be achieved. In some embodiments, the thermostat 600 may include a camera module. If a camera module is present, the thermostat may choose to display the dealer branding if a user is in the vicinity of the thermostat 600.

[0176] Referring now to FIG. 30, thermostat 600 may include unobtrusive dealer specified content on certain screens. In some embodiments, this may include an RSS feed of the dealer's website to keep the end user apprised of activity relating to the dealer. For example, thermostat 600 may include a news screen at the bottom of which exists a window which shows an RSS of a dealer's website. In other embodiments, this may include advertisements for dealer services and specials in which an end user has indicated an interest. Advertisements for partner companies and services may also be shown. In some embodiments, advertisement selection may be based on information made available to thermostat 600. For example, if a user has no events scheduled and it is a hot summer day, advertisements for a water park owned by a partner company may be selected for display to that user. In one embodiment, advertisements may be based on events scheduled for the user; for example, advertisements for partnered hotels may be selected if a user is scheduled to travel.

[0177] Thermostat 600 may communicate with the network, and as such, may be updated remotely. In some embodiments, changes to a skin may be made after purchase. For example, a user may purchase thermostat 600 from a first dealer who is then bought out by a second dealer. The second dealer may decide to rebrand thermostat 600 so that end users have updated contact information on hand for when they need assistance. The updated information also brings more awareness to the new owners, possibly generating more revenue.

[0178] Referring now to FIG. 31, thermostat 600 is shown to have a social media presence. Thermostat 600 may have social media profiles on different social media networks. In some embodiments, users may choose to post reviews, comments, skins, and settings for thermostat 600.

[0179] Thermostat 600 may include the Johnson Controls Inc. logo in all skins, settings, and configurations. The new slogan of Johnson Controls Inc. may be incorporated and featured in order to highlight changes and refresh impressions of the brand in a user's mind.

[0180] Thermostat 600 may communicate valuable data and feedback to a dealer. Thermostat may record and report how many service calls were provided or how many home visits were saved as a result of thermostat 600's features. In some embodiments, thermostat 600 records and reports the amount of advertisement revenue to the dealer. In some embodiments, thermostat 600 records any parts and equipment purchased through and/or for thermostat 600. In some embodiments, thermostat 600 reports any new equipment or parts purchased to the dealer. Thermostat 600 may provide a dealer with analysis of increased revenue and business as a result of thermostat 600. For example, each thermostat installed reports data which is aggregated by a revenue analyzer connected to the network. At the end of the fiscal year, a report is transmitted to the dealer detailing the revenue generated as a result of thermostat 600. The report may highlight that as a result of advertisements and direct dealer contact information made available by thermostat 600, 1000 more customers have been reached per month—an estimated \$100,000 increase in revenue.

[0181] In some embodiments, thermostat 600 may automate maintenance scheduling and consumables ordering. For example, filters may be ordered from the dealer automatically and delivered to a user when a filter change is needed. Thermostat 600 may prompt the user to call their dealer and schedule a maintenance appointment if the user wishes. In some embodiments, thermostat 600 may notify a user that it is time to schedule a maintenance appointment or to order consumables, giving users control over whether they wish to make any purchases or appointments.

[0182] Thermostat 600 may analyze a dealer's revenue and provide information and feedback targeted to improving performance and generating more business. For example, each thermostat installed by a particular dealer transmits dealer-relevant data to the network to be analyzed by a dealer performance analyzer. The results, showing that his customer base has not expanded in the last year, are sent to the dealer. The performance analyzer has discovered that the dealer has not been entering his contact information or using customized skins advertising his brand.

Algorithms/Analytics

[0183] Processing of data is done by memory module analytics service 2504. In some embodiments, thermostat

600 sends the data to be analyzed to the network, which transmits the data to a data analyzer 712 remote from thermostat 600. Thermostat 600 may receive input from a user to determine what analysis or algorithm is applied to the data or to a controller for a connected component.

[0184] Referring now to FIG. 32, thermostat 600 is able to graph power usage of a home. Thermostat 600 may process data periodically in order to display results instantaneously when requested by a user. Thermostat 600 may filter data based on user inputs, or thermostat 600 may offer several predetermined filters. In one embodiment, thermostat 600 is able to determine and display system energy usage per compressor stage, fan speed, or any quantifiable metric, allowing a user to make informed decisions regarding her energy usage habits. For example, thermostat 600 may analyze data from the past month and report that Jill has been using 20% more energy by setting the compressor to run in stage 3 instead of stage 2. This increase in energy over the 10 days the system has been at stage 3 has resulted in a net increase of \$5 over Jill's standard energy bill. With this information, Jill may decide whether she prefers efficiency or comfort, and adjust (or not) her usage accordingly.

[0185] Referring again to FIG. 32, thermostat 600 is able to compare one home's energy usage with another home of similar size and setup. For example, thermostat 600 may identify homes of similar square footage and equipment configuration which are located in a similar climate for comparison with the home it belongs to. In some embodiments, users may elect to view comparisons of their usage with that of a dissimilar home. For example, users may wish to estimate their energy usage with an addition to their current home or in a new home they plan to buy.

[0186] Referring now to FIG. 33, thermostat 600 may be compatible with external accessories. Thermostat 600 is shown to include port 3302. Thermostat 600 may contain multiple ports. Port 3302 may be compatible with USB, Thunderbolt, HDMI, Ethernet, 3.5 mm, or any other communications standards, and may be used to communicate tabulated, visual, audio, or any other type of data. FIG. 33 is shown to include external accessory 3304. In one embodiment, external accessory 3304 is exclusively compatible with thermostat 600. In some embodiments, external accessory 3304 is compatible with a variable of devices, and can transfer data between thermostat 600 and another device compatible with external accessory 3304. For example, external accessory is a USB dongle which can store data to be analyzed from thermostat 600 and transfer the data to a laptop. The results of the analysis, including any visual representations, may be transferred to thermostat 600 for display. In some embodiments, external accessory 3304 is able to communicate with user device 1502 and may be used during installation for troubleshooting. For example, external accessory 3304 may be a phone dongle which assists a technician in troubleshooting wiring installation such as a Cat5e tester.

[0187] In some embodiments, thermostat 600 is able to analyze data transferred from another source through external accessory 3304 and generate a report for display. For example, thermostat 600 may receive billing data from external accessory 3304 and integrate billing data with usage and operational data to generate a report correlating a user's usage habits and behavior with their energy cost. External accessory 3304 may provide additional capabilities to thermostat 600. External accessory 3304 may contain a data

analyzer 712 or a data mapping module. In some embodiments, external accessory 3304 contains communications means which thermostat 600 does not otherwise have. For example, thermostat 600 may only have communications electronics which are configured for Bluetooth communications. External accessory 3304 contains communications electronics which allow thermostat 600 to communicate over WiFi, expanding the network of devices and applications with which thermostat 600 can interact. In one embodiment, a previous model of thermostat may be retrofit with external accessory 3304 to gain functionality of features of thermostat 600.

[0188] Thermostat 600 may analyze system performance to determine and monitor system health. Thermostat 600 may compare current performance with historical data to determine whether each piece of equipment or component of the system is fully functional. For example, thermostat 600 logs the energy usage of HVAC equipment. Thermostat 600 identifies the current energy usage of the HVAC equipment and compares the current energy usage of the HVAC equipment to the historical energy usage of the HVAC equipment. In another example, thermostat 600 may find that the compressor has been on the same stage for a week, but system performance has decreased in the past two hours. Thermostat 600 may determine that the compressor is no longer functioning correctly, and prompt the user to call the dealer to schedule an appointment. Thermostat 600 may be able to provide an estimate of the lifetime of consumables based on historical service and operating condition data. For example, thermostat 600 may estimate that the air filter will need to be replaced in 10 days due to records that it had last been replaced 40 days ago during a service call, and that the system is operating at high capacity because it is summer. Thermostat 600 may prompt the user to order a new filter, automatically order a new filter, or ask the user if he would like to schedule a maintenance appointment.

[0189] Thermostat 600 is able to provide tips and suggestions to users based on analysis of their usage and habits. Thermostat 600 may allow users to input preferences with regards to efficiency or comfort. Thermostat 600 may allow users to input a target energy bill amount. With these guidelines, thermostat 600 may be able to suggest setpoints within a reasonable range of a user's current setpoint which may help the user to achieve their goal payment. For example: Jack wishes to reduce his monthly electricity bill from \$300 to \$250. It is August, and Jack currently sets his thermostat to 66° F. Thermostat 600 may analyze billing data and system performance from the past two Augusts to determine and propose a new setpoint. Thermostat 600 may suggest to Jack that moving the setpoint up by just two degrees to 68° F. may lower his electricity bill to \$275, and that moving the setpoint up to 70° F. may allow him to reduce his electricity bill to \$250. This situation gives Jack options and provides a middle ground choice if he wants to make a compromise.

[0190] Thermostat 600 may give users tips based generally on their indication of preference for either comfort or efficiency. In some embodiments, thermostat 600 may be able to draw from a preformed pool of general tips relating to either increased user comfort or increased energy efficiency. This prepopulated source of tips allow thermostat 600 to quickly provide simple tips to a user. For example, if Jill has indicated that she prefers efficiency to comfort, thermostat 600 may periodically display tips for reducing

energy usage, such as raising the setpoint on a hot day, closing the windows when running the conditioning system, or choosing conservative stage progressions for a compressor. It is understood that many other tips may be given, and that tips of similar weight are given for users who indicate a preference for comfort. In some embodiments, general tips may be correlated with actions a user is currently taking. For example, if a user, who has indicated a preference for efficiency, is lowering the setpoint on a hot day, thermostat 600 may display a prompt informing the user that their current course of action will result in a decrease in energy efficiency.

[0191] Thermostat 600 may offer suggestions to a user based on his history of energy consumption and system settings. For example, thermostat 600 may analyze Jack's energy consumption from the past year, as well as his operational settings. He has increased fan speed, increasing energy usage, but has not seen any changes in performance. Thermostat 600 may alert Jack that he can reduce his energy usage without sacrificing comfort.

[0192] Thermostat 600 settings may be shared with other users. In one embodiment, thermostat 600 may communicate with other thermostats connected to the network to find similar homes with similar settings. When system with settings that match closely to that with which thermostat 600 is associated is found, and that system is performing better in the area of a user's preference, either efficiency or comfort, thermostat 600 may suggest changing current settings to match those of the other system exactly.

[0193] Thermostat 600 may be able to provide a user with a suggested operation procedure or stage progression based on the cost determined per stage as well as the estimated time to reach a setpoint. In one embodiment, a user indicates her preference for comfort, and thermostat 600 offers staging suggestions based on her calculated cost per stage to increase efficiency. Staging suggestions include which stages to proceed to or to skip, and how long it will take for the system to reach the setpoint. Several options with varying total times and energy consumption may be offered.

[0194] Thermostat 600 may analyze the performance of a system and make recommendations to assist a user in meeting their goals and maintaining functionality of their system. In some embodiments, thermostat 600 may offer a suggestion on whether a home should run on gas or electricity. In other embodiments, thermostat 600 may communicate with a user maintenance portal. The maintenance portal may be a web-based application or a stand-alone application. The maintenance portal allows users to schedule seasonal check-ups and make appointments for house calls. Memory 704 of thermostat 600 may contain a schedule analyzer. The schedule analyzer may select time slots during which a user is not scheduled for any events and suggest those time slots as appointment times in the maintenance portal. In some embodiments, the maintenance portal automatically creates reminders for necessary maintenance based on service records. In other embodiments, users create reminders to schedule maintenance and review service records. Thermostat 600 may determine that a piece of equipment is running for a longer amount of time than usual to achieve the same results. In some embodiments, thermostat 600 may suggest to a user that the equipment may need repairs in order to increase efficiency and comfort, and offer to call the dealer.

[0195] Thermostat 600 provides many opportunities for partnerships over social media platforms. Thermostat 600 may allow users to command changes from social media posts. For example: Jill tweets privately at thermostat 600: @thermostat100 72, and thermostat 600 tweets back: @jillandjack Command received. Thermostat 600 may have a unique Twitter handle. It is understood that any social media platform may be used to post changes to thermostat 600. In some embodiments, thermostat 600 may allow actions specific to a social media platform to command changes. For example: Jack likes system settings for a thermostat which Jill has posted on Facebook. Thermostat 600 detects this action and applies the settings. In some embodiments, companies or dealers may promote well-tested and popular settings for users to try in order to increase traffic to their website or related products. In some embodiments, partnered companies may create skins for users to download or purchase and apply. For example: a fitness tracker manufacturer may create a health-centric skin which collects data from a connected fitness tracker and provides tips and suggestions for healthy living.

[0196] Referring now to FIG. 34, a process 3400 for determining a time to setpoint for HVAC equipment 2420 and making recommendations with thermostat 600 is shown, according to an exemplary embodiment. The time to setpoint can be an amount of time required to reach the setpoint based on current or predicted environmental conditions and the capability of the HVAC system operated by the thermostat. In FIG. 34, thermostat 600 is configured to receive a requested setpoint (step 3402). In some embodiments, the setpoint is a temperature setpoint, a humidification/dehumidification setpoint, and/or any other environmental setpoint. In some embodiments, the setpoint request is made through user interface 612 of thermostat 600. In some embodiments, the setpoint request is made through social media activity. In some embodiments, the setpoint request is made through a wireless connection such as wifi, Bluetooth, or NFC. when a user checks into thermostat 600. Thermostat 600 is configured to determine if the setpoint requested in step 3402 is achievable (step 3404). Thermostat 600 makes the determination that the setpoint is achievable based on a plurality of factors. The factors can include a thermal load, a time of day, a connected electrical grid status, agreements to not operate equipment such as at certain times of the day, weather conditions, historical data, equipment status and functionality and any other factor that affects the ability of the HVAC equipment 2420 to reach the requested setpoint. In some embodiments, a level of occupancy can be inferred from the thermal load derived time to setpoint data.

[0197] In some embodiments, thermostat 600 is configured to determine if a setpoint is unachievable based on a comparison of zones in a home. In some embodiments, there may be a plurality of zones in a home. Each zone may be heated and conditioned to a different temperature. In some embodiments, thermostat 600 controls multiple zones. For example, thermostat 600 may be cooling zones Zone A and Zone B to 65 degrees Fahrenheit. Thermostat 600 may identify that Zone A reaches 65 degrees Fahrenheit from a room temperature of 80 degrees Fahrenheit in 10 minutes. Thermostat 600 may identify that Zone B has taken 25 minutes to reach 75 degrees Fahrenheit from a room temperature of 80 degrees Fahrenheit. In some embodiments, thermostat 600 may be configured to determine that Zone B cannot reach 65 degrees Fahrenheit.

[0198] In some embodiments, when a zone cannot reach a setpoint based on a zone comparison, thermostat 600 identifies possible reasons why the zone cannot reach the setpoint. In some embodiments, the thermostat 600 may identify the time of day and the location of the zones. For example, at 6:30 P.M., thermostat 600 may identify that one zone on the west side of the home is not reaching its setpoint as compared to another zone on the east side of the home. Thermostat 600 may provide recommendations to the user (step 3408) that are the result of the zone comparison. For example, thermostat 600 may notify a user that he or she should wait until the sun goes down before attempting to request a low setpoint and/or may tell a user to close his shades. For example, thermostat 600 may be configured to tell a user “In three hours it will be dark outside, you should wait three hours before attempting this setpoint.”

[0199] In some embodiments, thermostat 600 may be configured to monitor and/or operate dampers and fans. In some embodiments, thermostat 600 may make a comparison between the two zones based on the differences between the zones such as a ceiling fan running, dampers being open or closed, a stove generating heat, and any other piece of equipment thermostat 600 may be able to monitor and compare between two zones. For example, thermostat 600 may determine that Zone A is reaching a temperature of 65 degrees Fahrenheit from a room temperature of 80 degrees Fahrenheit but Zone B reaches a temperature of 75 degrees Fahrenheit from a room temperature of 80 degrees Fahrenheit over the course of an hour. Thermostat 600 may identify that Zone A has a fan running and Zone B is a kitchen and has a stove turned on and a fan turned off. Thermostat 600 can provide recommendations to the user (step 3408) such as, “You have a stove running, you won’t be able to reach the setpoint” and/or “Turn on the fan in Zone B”.

[0200] Still referring to FIG. 34, when thermostat 600 determines that the setpoint is not achievable (step 3404), thermostat 600 informs the user that the setpoint is not achievable (step 3408). Thermostat 600 can inform the user that the setpoint is not achievable in a number of ways. In some embodiments, the thermostat 600 displays a notification to the user through user interface 612. In some embodiments, the thermostat 600 sends a notification to the user that the setpoint is not achievable when the user checks in with thermostat 600 via NFC. In some embodiments, the thermostat 600 sends a notification to the user that the setpoint is not achievable by generating a social media notification.

[0201] Still referring to FIG. 34, thermostat 600 is configured to make suggestions when thermostat 600 determines that the requested setpoint is not achievable (step 3408). In some embodiments, the suggestion includes a plurality of suggestions that can be served to a user through NFC, a social media notification, and thermostat 600’s user interface 612. In some embodiments, suggestions include closing drapes, closing windows, closing dampers to unused spaces, and turning on fans. In some embodiments, the suggestions can be implemented by HVAC equipment 2420. In some embodiments, the suggestions include a plurality of recommended setpoints and a time to setpoint for each setpoint. Thermostat 600 can determine the time to setpoint for each time to setpoint by using a plurality of factors. The factors can include thermal load, time of day, electrical grid status, weather, historical equipment data, and equipment functionality.

[0202] Still referring to FIG. 34, thermostat 600 is configured to control HVAC equipment 2420 to the requested setpoint when thermostat 600 determines that the requested setpoint is achievable. Thermostat 600 serves a notification to the user of what the time to setpoint is for the requested setpoint. In some embodiments, thermostat 600 displays the time to setpoint on user interface 612. In some embodiments, thermostat 600 sends a notification to a user device via NFC when a user checks in with thermostat 600. In some embodiments, thermostat 600 sends a notification to a user through a social media notification.

[0203] In some embodiments, thermostat 600 displays the time to setpoint on user interface 612. Thermostat 600 may display the time to setpoint in a number of graphical forms. In some embodiments, thermostat 600 displays the countdown timer as a ticking countdown clock which may be refreshed periodically. In some embodiments, the graphical form may be an hour glass. The hour glass may change based on changes in the time to setpoint. In some embodiments, a percentage bar is the graphical form that thermostat 600 displays time to setpoint.

[0204] In some embodiments, thermostat 600 determines the time to setpoint for a requested setpoint and preemptively adjusts the setpoints based on expected occupancy for a building. In some embodiments, thermostat 600 identifies an expected occupancy of a building from scheduler 726, social media server 2506, calendar server 2508, and mobile application server 2507. For example, a building may be unoccupied at 1:00 P.M. Thermostat 600 identifies that Tom will be in the building at 2:00 P.M. based on a social media message he sent to Joe. The social media message may read, “I will be at the building at 2:00 P.M.”. The thermostat 600 knows that Tom likes a setpoint of 70 degrees Fahrenheit. Thermostat 600 determines that it will take 10 minutes to reach a setpoint of 70 degrees Fahrenheit. Thermostat 600 waits until 1:50 P.M. and then adjusts the setpoint to 70 degrees Fahrenheit. The building reaches a temperature of 70 degrees Fahrenheit at 2:00 P.M. when Tom reaches the building.

[0205] Referring now to FIG. 35, a process 3500 for identifying if a fault can be serviced by a homeowner and suggestions to clear the fault are shown, according to an exemplary embodiment. In FIG. 35, thermostat 600 is configured to detect and identify faults (step 3502). Thermostat 600 may receive fault information from HVAC equipment through bidirectional communication as described in FIG. 21. Thermostat 600 may use the fault codes of the identified faults to determine possible solutions to the fault. If thermostat 600 identifies that the faults identified can be serviced and fixed by a homeowner (step 3504), thermostat 600 can display fault information and instructions to fix the fault on the user interface 612 of thermostat 600 (step 3506).

[0206] In some embodiments, thermostat 600 may ask the user if the user would like to perform the instructions to fix the fault or if the user would like to immediately call a dealer. The instructions may be to power cycle a breaker, check filters for derbies, check registers for blockage, or any other instruction that a homeowner could perform. Thermostat 600 can then check if the fault has been cleared (step 3508). If the fault has been cleared, the thermostat 600 can resume the operation of the HVAC equipment (step 3510). If the thermostat determines that the fault has not been cleared, the thermostat is configured to display dealer information on the user interface 612 of thermostat 600. The

dealer information may include an address of contact information for the dealer. In some embodiments, the thermostat 600 prompts the user to directly contact the dealer from thermostat 600. In some embodiments, thermostat 600 may automatically contact the dealer. In some embodiments, thermostat 600 may request permission before contacting the dealer.

[0207] Referring now to FIG. 36, a process 3600 for determining if setpoints selected by a user are energy efficient and suggesting energy efficient setpoints to the user is shown according to an exemplary embodiment. Thermostat 600 can be configured to receive setpoints from a user (step 3602). Thermostat 600 can be configured to identify energy efficient setpoints that are within an offset value from the received setpoint (step 3604). The energy efficient setpoints are setpoints that thermostat 600 determines will use less energy. In some embodiments, thermostat 600 uses historical data gathered and logged from HVAC equipment connected to thermostat 600 to determine energy efficient setpoints. In some embodiments, the historical data is gathered through bidirectional communication between thermostat 600 and the connected HVAC equipment. In some embodiments, the historical data includes information regarding the connected HVAC equipment. The information can include equipment tonnage, runtime of the HVAC equipment, compressor speed, and any other relevant information about the connected HVAC equipment. In some embodiments, thermostat 600 gathers the current equipment performance from the connected HVAC equipment through bidirectional communication and uses the current information to determine energy efficient setpoints. In some embodiments, the thermostat 600 identifies energy efficient setpoints further based on indoor/outdoor temperature. In some embodiments, the energy efficient setpoint may be calculated on a remote server and communicated to thermostat 600.

[0208] In some embodiments, thermostat 600 displays the energy efficient setpoints to the user along with a calculated cost of each setpoint (step 3606). In some embodiments, thermostat 600 may display a cost comparison between multiple setpoints. In some embodiments, thermostat 600 uses past energy bills to determine the cost of running each energy efficient setpoint. Thermostat 600 is configured to receive a command from a user to either accept one of the energy efficient setpoints or reject the energy efficient setpoints (step 3608). If the user accepts one of the energy efficient setpoints, thermostat 600 implements the energy efficient setpoint selected (step 3612). If the user rejects the energy efficient setpoint, thermostat 600 does not change the setpoint (step 3610).

[0209] Referring now to FIG. 37, process 3700 for updating and displaying a dealer's contact information and/or branding is shown according to an exemplary embodiment. In some embodiments, process 3700 is executed on one or more processors or other circuits configured to execute process 3700. In some embodiments, thermostat 600 receives the updates from a network connection, the Internet, a transfer of data via NFC, and/or any other method for updating thermostat 600. Thermostat 600 is configured to determine when to update a dealer's information and/or branding (step 3702). In some embodiments, the dealer's information and/or branding along with dealer related settings are stored on thermostat 600 in remote data storage 718. In some embodiments, thermostat 600 is connected to

the internet and/or any other network and can retrieve dealer information and/or branding from a web server. In some embodiments, thermostat 600 is configured to update the dealer's information and/or branding when a set amount of time has passed. In some embodiments, thermostat 600 is configured to update the dealer's information and/or branding when thermostat 600 enters a commissioning mode. In some embodiments, thermostat 600 is configured to update or change the dealer's information, related settings, and/or branding when a contract between a third party and the dealer has started or ended. In some embodiments, thermostat 600 is configured to receive new branding when a dealer updates their branding, the dealer associated with the thermostat changes from a first dealer to a second dealer, and/or thermostat 600 is installed for a first time. In some embodiments, the dealer pays the third party to have the dealer's information stored and advertised on thermostat 600. In some embodiments, the dealer's information and any relevant settings must be updated according to the status of the contract (e.g. payments being on time or late). In some embodiments, relevant settings are the frequency at which thermostat 600 displays the contact information of the dealer.

[0210] Still referring to FIG. 37, thermostat 600 is configured to update the dealer's information and/or branding (step 3704). In some embodiments, thermostat 600 receives dealer information items which include an address of the dealer, a phone number of the dealer, a web address of the dealer, a configurable branding, and any other information the dealer wants to display on user interface 612 of thermostat 600. In some embodiments, thermostat 600 receives dealer related settings. The settings may include a frequency at which thermostat 600 displays the dealer information. In some embodiments, the settings include a confirmation that the dealer has made advertising payments on time to the third party. In some embodiments, there is a setting which stops the display of the dealer's contact information when the dealer has not made payments on time and/or the dealer has cancelled a contract with the third party. In some embodiments, the dealer information may change to default dealer settings if the contract with the original dealer is cancelled. In some embodiments, the settings include what combination of dealer information items to display in a certain circumstance. For example, there may be a setting which causes thermostat 600 to display the dealer's logo every 20 minutes. There may also be a setting which causes thermostat 600 to display the dealer's phone number when thermostat 600 has a fault. In some embodiments, thermostat 600 receives custom branding associated with a dealer.

[0211] Still referring to FIG. 37, thermostat 600 decides when it should display the dealer information (step 3706). In some embodiments, thermostat 600 monitors thermostat 600 events and displays the dealer information when an event occurs. In some embodiments, the event is that a set amount of time has passed since thermostat 600 last displayed the dealer information. Thermostat 600 may determine that a set amount of time has passed and that it is appropriate to advertise the dealer information to the user via the user interface 612 of thermostat 600. In some embodiments, thermostat 600 displays the dealer's information when thermostat 600 identifies that there is a system fault. In some embodiments, thermostat 600 displays the dealer information and a service notification when thermostat 600 determines that the thermostat 600 and any equipment connected

to thermostat **600** needs a maintenance check. In some embodiments, the dealer information is displayed as a result of a maintenance schedule or a determination by thermostat **600** that there may be a potential issue with thermostat **600** or any equipment connected to thermostat **600**. In some embodiments, thermostat **600** displays the dealer's contact information when thermostat **600** identifies that a user has been looking through thermostat **600** settings or configurations through the user interface **612** of thermostat **600** for a time longer than a threshold time. For example, if a user has spent 20 minutes looking through thermostat **600** settings, thermostat **600** may display a customer service number for the user to dial and receive help in whatever task the user is trying to complete with thermostat **600**.

[0212] Still referring to FIG. 37, thermostat **600** displays dealer information on the user interface **612** of thermostat **600** (step 3708). In some embodiments, thermostat **600** displays the phone number of a dealer, the address of a dealer, a dealer logo and/or name, or any other information that the dealer wants to display. In some embodiments, thermostat **600** displays a button which allows a user to directly contact the dealer through thermostat **600**. In some embodiments, thermostat **600** displays a notification that a dealer technician is located within a set distance from thermostat **600**. For example, thermostat **600** determines that there is a fault with equipment connect to thermostat **600**. Thermostat **600** determines that a dealer technician is in the neighborhood of the house where the thermostat **600** is located. Thermostat **600** displays a notification that a dealer technician is in the area and has time to stop by and take a look at the fault displayed on thermostat **600**. In some embodiments, a button may be displayed on user interface **612**. Pushing the button on the thermostat **600** may cause a smartphone of the user to make a call to the dealer. In some embodiments, thermostat **600** may pass contact information to the smartphone via a wireless connection. In some embodiments, the smartphone may use a camera to collect the contact information presented on the thermostat **600**. The contact information may be presented on the display or encoded in a barcode or Q code which may be presented on the display.

[0213] Referring again to FIG. 24, thermostat **600** is capable of communicating with a variety of devices, and entities, including utility providers. In some embodiments, thermostat **600** may control connected systems. Thermostat **600** may analyze energy usage and billing data from the utility provider and make decisions on which connected appliances or pieces of equipment can be controlled to control load. In some embodiments, thermostat **600** may communicate with a smart meter and adjust load according to time-of-use rates or demand-response feedback. Thermostat **600** may analyze all data from the system and integrate energy usage to build efficient control algorithms, make more informed decisions, or provide more effective suggestions and tips. In some embodiments, thermostat **600** tailors all derived content to a user's preferences and past actions and decisions.

[0214] Thermostat **600** may adjust existing and create new control algorithms based on parameters such as time constraints, user preferences, and occupancy detected. In some embodiments, thermostat **600** may skip compressor stages in staging progressions when there is a limited amount of time available for the system to reach the setpoint. For example: Jill is hosting a party, which begins at 1800, today. There is

only an hour until the party begins, but the system is expected to transition from 72° F. to 68° F. Thermostat **600** may determine that there is not enough time for the standard staging progression, and skip from a low stage to a high stage in order to meet the deadline for reaching the setpoint.

[0215] Thermostat **600** may adjust control algorithms based on a user's indicated preference for comfort or efficiency. In some embodiments, thermostat **600** participates in demand-response based on occupancy levels, appropriately restricting or permitting energy usage depending on detected occupancy. Thermostat **600** may determine occupancy from inputs received and command more efficient scheduling when no occupancy is detected. In some embodiments, thermostat **600** may lengthen run times when a home is unoccupied. Thermostat **600** may adjust scheduling and operations based on detected activity levels within the home. Thermostat **600** may detect that a user is not home if she has been tagged in an event hosted in a location different from home. For example, if Jill has been tagged in an event at George's house, thermostat **600** may determine that Jill is not home, and that the home is unoccupied. In some embodiments, thermostat **600** may determine that a user is not home if any social media platform has indicated that they are in a location other than home.

[0216] Thermostat **600** may receive weather input upon which a portion of system controls decisions are based. Thermostat **600** may communicate with a weather station, a weather service, or a network from which weather data can be retrieved. In some embodiments, thermostat **600** may adjust scheduling based on weather forecasts in order to better prepare for the upcoming operating conditions. Thermostat **600** may adjust defrosting operations based on the forecast. In some embodiments, thermostat **600** may detect the minimum temperature which will keep pipes from freezing while a home is unoccupied in the winter. Thermostat **600** may receive data from local sensors outside of the home and adjust conditions based on outdoor conditions. For example: a desert environment experiences a large range of temperatures every day; thermostat **600** may preempt steep temperature changes by anticipating the schedule of the changes and adjusting operation accordingly. Thermostat **600** may detect outdoor conditions and command the condenser to adjust the volume of air drawn from the outside to increase efficiency.

Configuration of Exemplary Embodiments

[0217] The construction and arrangement of the systems and methods as shown in the various exemplary embodiments are illustrative only. Although only a few embodiments have been described in detail in this disclosure, many modifications are possible (e.g., variations in sizes, dimensions, structures, shapes and proportions of the various elements, values of parameters, mounting arrangements, use of materials, colors, orientations, etc.). For example, the position of elements may be reversed or otherwise varied and the nature or number of discrete elements or positions may be altered or varied. Accordingly, all such modifications are intended to be included within the scope of the present disclosure. The order or sequence of any process or method steps may be varied or re-sequenced according to alternative embodiments. Other substitutions, modifications, changes, and omissions may be made in the design, operating conditions and arrangement of the exemplary embodiments without departing from the scope of the present disclosure.

[0218] The present disclosure contemplates methods, systems and program products on any machine-readable media for accomplishing various operations. The embodiments of the present disclosure may be implemented using existing computer processors, or by a special purpose computer processor for an appropriate system, incorporated for this or another purpose, or by a hardwired system. Embodiments within the scope of the present disclosure include program products comprising machine-readable media for carrying or having machine-executable instructions or data structures stored thereon. Such machine-readable media can be any available media that can be accessed by a general purpose or special purpose computer or other machine with a processor. By way of example, such machine-readable media can comprise RAM, ROM, EPROM, EEPROM, CD-ROM or other optical disk storage, magnetic disk storage or other magnetic storage devices, or any other medium which can be used to carry or store desired program code in the form of machine-executable instructions or data structures and which can be accessed by a general purpose or special purpose computer or other machine with a processor. Combinations of the above are also included within the scope of machine-readable media. Machine-executable instructions include, for example, instructions and data which cause a general purpose computer, special purpose computer, or special purpose processing machines to perform a certain function or group of functions.

[0219] Although the figures show a specific order of method steps, the order of the steps may differ from what is depicted. Also two or more steps may be performed concurrently or with partial concurrence. Such variation will depend on the software and hardware systems chosen and on designer choice. All such variations are within the scope of the disclosure. Likewise, software implementations could be accomplished with standard programming techniques with rule based logic and other logic to accomplish the various connection steps, processing steps, comparison steps and decision steps.

What is claimed is:

1. A thermostat for a building space, the thermostat comprising:

a communications interface configured to engage in bidirectional communications with heating, ventilation, or air conditioning (HVAC) equipment and to receive an indication of a current heating or cooling load from the HVAC equipment; and

a processing circuit configured to:

determine an occupancy of the building space based on the indication of the current heating or cooling load received from the HVAC equipment; and

operate the HVAC equipment based on the determined occupancy of the building space.

2. The thermostat of claim **1**, wherein the processing circuit is further configured to determine load metrics based, wherein the load metrics comprise a time to setpoint calculated from at least one of:

known capabilities of the HVAC equipment;

the heating and cooling load;

a time of day;

weather conditions; and

historical equipment data.

3. The thermostat of claim **1**, wherein the communications interface is further configured to communicate with a fitness

tracker, wherein the indication of the current heating and cooling load is further received from the fitness tracker.

4. The thermostat of claim **3**, wherein the indication of the current heating and cooling load received from the fitness tracker is based on the physical activity of a user wearing the fitness tracker.

5. The thermostat of claim **1**, further comprising a user interface configured to display dealer information;

wherein the processing circuit is further configured to update the dealer information in response to a determination that at least one of:

a predetermined amount of time has passed since the dealer information was last updated;

the thermostat is in a commissioning mode;

a dealer contract has started; and

a dealer contract has ended.

6. The thermostat of claim **1**, further comprising a user interface configured to display dealer information;

wherein the processing circuit is configured to cause the user interface to display the dealer information in response to detecting one or more thermostat events comprising at least one of:

a determination that a predetermined amount of time has passed;

detecting a system fault; and

a determination that a user is adjusting settings in the thermostat for a time longer than a predetermined amount of time.

7. The thermostat of claim **1**, further comprising a user interface configured to display dealer information;

wherein the processing circuit is further configured to hide the dealer information in response to receiving a notification to hide the dealer information, wherein the notification is received by the communications interface.

8. The thermostat of claim **7**, wherein the notification received by the communications interface comprises at least one of:

a notification that the dealer is late on a payment; and

a notification that the dealer has canceled a contract.

9. The thermostat of claim **1**, further comprising a user interface configured to display dealer information;

wherein the processing circuit is further configured cause the user interface to display the dealer information when a fault is detected, the dealer information comprising at least one of:

a button to contact the dealer;

a dealer phone number;

a dealer address; and

a dealer store hours.

10. A method for operating a bidirectional thermostat, the method comprising:

determining a time to setpoint for a building space; and displaying the time to setpoint on a user interface.

11. The method of claim **10**, wherein the method further comprises determining load metrics, wherein the load metrics comprise the time to setpoint calculated from at least one of:

known capabilities of the HVAC equipment;

the heating and cooling load;

time of day;

weather conditions; and

historical equipment data.

12. The method of claim **10**, further comprising causing the user interface to display a recommendation for achieving a requested setpoint, wherein the recommendation comprises waiting a predetermined amount of time before attempting the requested setpoint, closing shades in a zone of a building, and turning on a fan in the zone of the building.

13. The method of claim **10**, further comprising determining if a requested setpoint is achievable based on comparing a first time to setpoint for a first zone of a building space and a second time to setpoint for a second zone of the building space.

14. The method of claim **10**, further comprising determining the amount of time required to reach the requested setpoint when the requested setpoint is determined to be achievable.

15. A thermostat for a building space, the thermostat comprising:

a communications interface configured to engage in bidirectional communications with heating, ventilation, or air conditioning (HVAC) equipment and to receive an indication of a current heating or cooling load from the HVAC equipment; and

a processing circuit configured to determine if a requested setpoint is achievable based on the load.

16. The thermostat of claim **15**, wherein the processing circuit is configured to determine if the requested setpoint is achievable further based on factors comprising:

a status of an electrical grid;
weather conditions; and
a time of day.

17. The thermostat of claim **15**, wherein the processing circuit is further configured to determine an amount of time required to reach the requested setpoint when the requested setpoint is determined to be achievable.

18. The thermostat of claim **15**, wherein the processing circuit is further configured to determine an amount of time required to reach the requested setpoint based on factors comprising:

a status of an electrical grid;
weather conditions; and

historical data associated with the HVAC equipment.

19. The thermostat of claim **15**, wherein the processing circuit is configured to determine if a requested setpoint is achievable further based on comparing a first time to setpoint for a first zone of the building space and a second time to setpoint for a second zone of the building space.

20. The thermostat of claim **15**, wherein the processing circuit is further configured to cause a user interface to display a recommendation for achieving the requested setpoint, wherein the recommendation comprises waiting a predetermined amount of time before attempting the requested setpoint, closing shades in a zone of the building, and turning on a fan in the zone of the building.

* * * * *