



US010341138B2

(12) **United States Patent**
Subramanian et al.

(10) **Patent No.:** **US 10,341,138 B2**
(45) **Date of Patent:** **Jul. 2, 2019**

(54) **SPANNING TREE PROTOCOL ENABLED N-NODE LINK AGGREGATION SYSTEM**

(71) Applicant: **Dell Products L.P.**, Round Rock, TX (US)

(72) Inventors: **Saye Balasubramaniam Subramanian**, Tamil Nadu (IN); **Ravisekhar Akkineni**, Telangana (IN)

(73) Assignee: **Dell Products L.P.**, Round Rock, TX (US)

(*) Notice: Subject to any disclaimer, the term of this patent is extended or adjusted under 35 U.S.C. 154(b) by 87 days.

(21) Appl. No.: **15/590,855**

(22) Filed: **May 9, 2017**

(65) **Prior Publication Data**

US 2018/0331855 A1 Nov. 15, 2018

(51) **Int. Cl.**

H04L 12/46 (2006.01)
H04L 12/709 (2013.01)
H04L 29/06 (2006.01)
H04L 12/707 (2013.01)
H04L 12/703 (2013.01)
H04L 12/753 (2013.01)
H04L 12/24 (2006.01)

(52) **U.S. Cl.**

CPC **H04L 12/462** (2013.01); **H04L 12/4625** (2013.01); **H04L 41/30** (2013.01); **H04L 45/22** (2013.01); **H04L 45/245** (2013.01); **H04L 45/28** (2013.01); **H04L 45/48** (2013.01); **H04L 69/12** (2013.01); **H04L 41/0893** (2013.01)

(58) **Field of Classification Search**

CPC ... H04L 12/462; H04L 41/12; H04L 41/0893; H04L 69/12; H04L 45/245; H04L 41/16
See application file for complete search history.

(56) **References Cited**

U.S. PATENT DOCUMENTS

9,059,930 B2 6/2015 Janardhanan et al.
9,288,138 B2 3/2016 Ghanwani et al.
2011/0222440 A1* 9/2011 Phillips H04L 45/48
370/256
2014/0153570 A1* 6/2014 Balakavi H04L 45/7453
370/390
2018/0287820 A1* 10/2018 Mayer-Wolf H04L 12/4645

OTHER PUBLICATIONS

Saye Balasubramaniam Subramanian and Senthil Nathan Muthukaruppan, "Spanning Tree Protocol Enabled N-Node Link Aggregation System," Filed May 3, 2017, U.S. Appl. No. 15/586,088, 39 Pages.

* cited by examiner

Primary Examiner — Feben Haile

(74) Attorney, Agent, or Firm — Haynes and Boone, LLP

(57) **ABSTRACT**

A STP n-node VLT system includes a first VLT device with a first virtual port, and a second VLT device with a LAG port, a non-LAG port, and a second virtual port coupled to the first virtual port. A STP engine designates the first VLT device as a root bridge and, in response, designates the first virtual port a designated port and the second virtual port a root port. The STP engine then designates a networking device coupled to the LAG port as the root bridge based on it having a higher priority than the first VLT device. Then STP engine then determines that a non-LAG link between the networking device and the second VLT device has caused the redesignation of the second virtual port as an alternate port and the non-LAG port as a root port, and swaps the designations of the second virtual port and the non-LAG port.

20 Claims, 29 Drawing Sheets

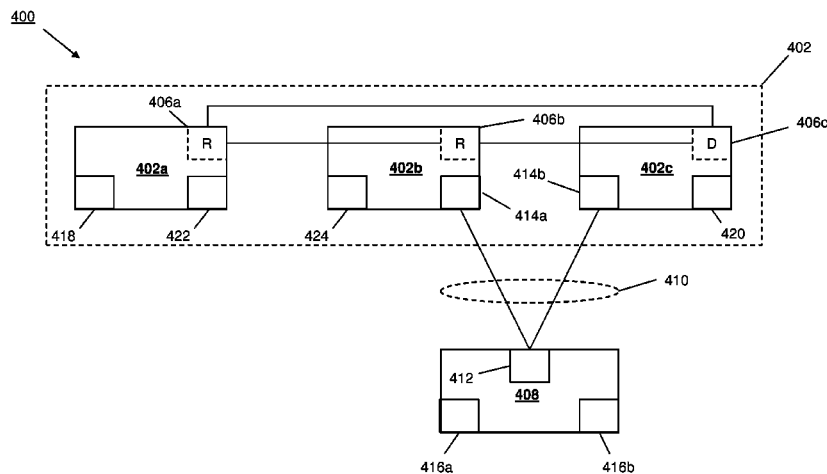

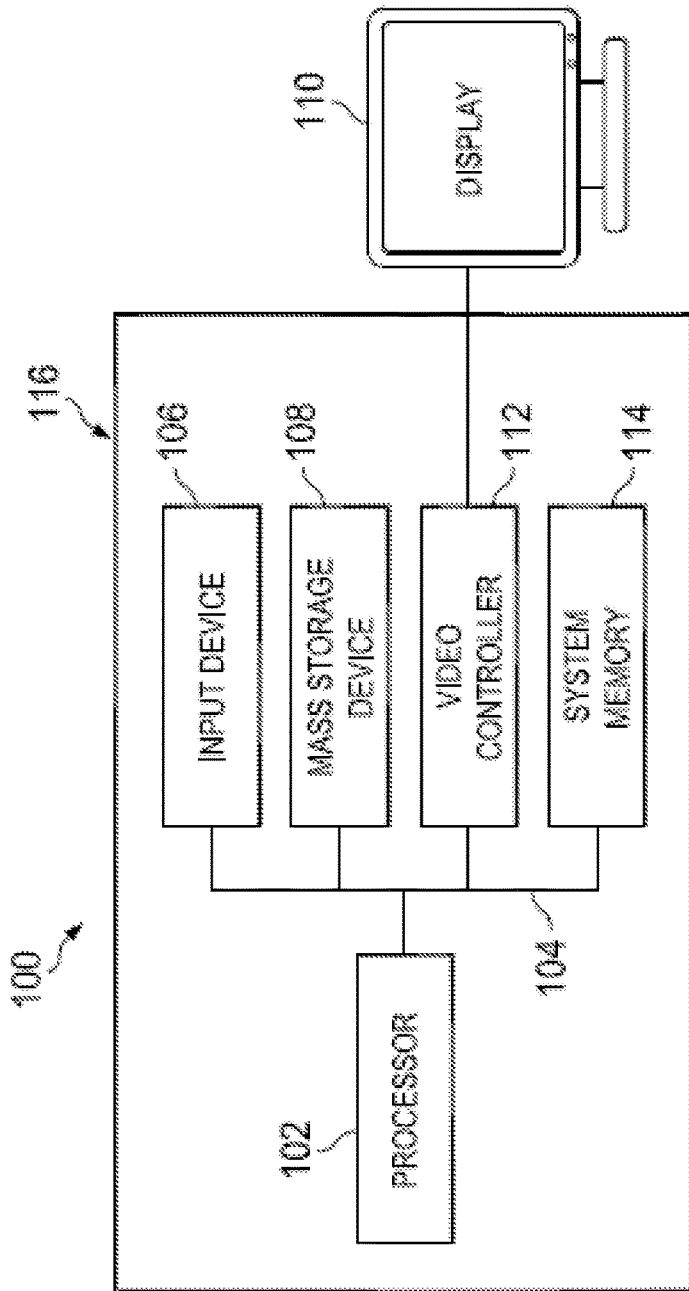

FIG. 1

200 ↗

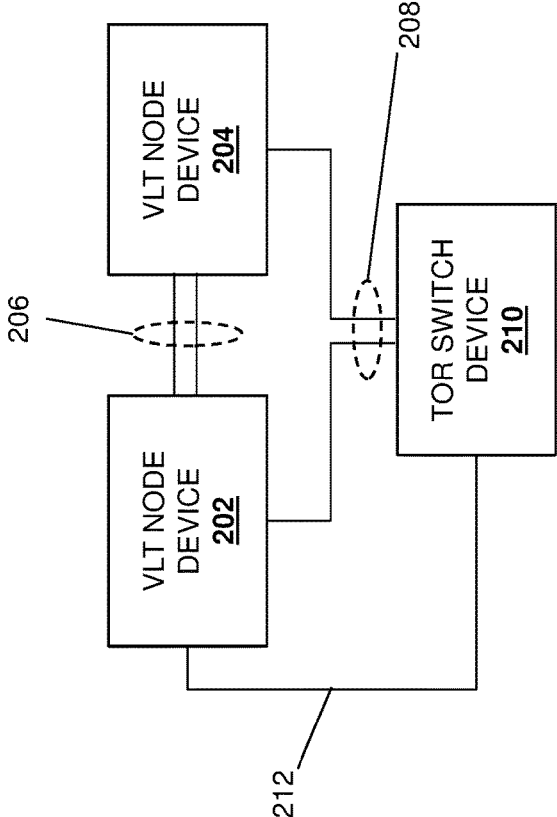

FIG. 2

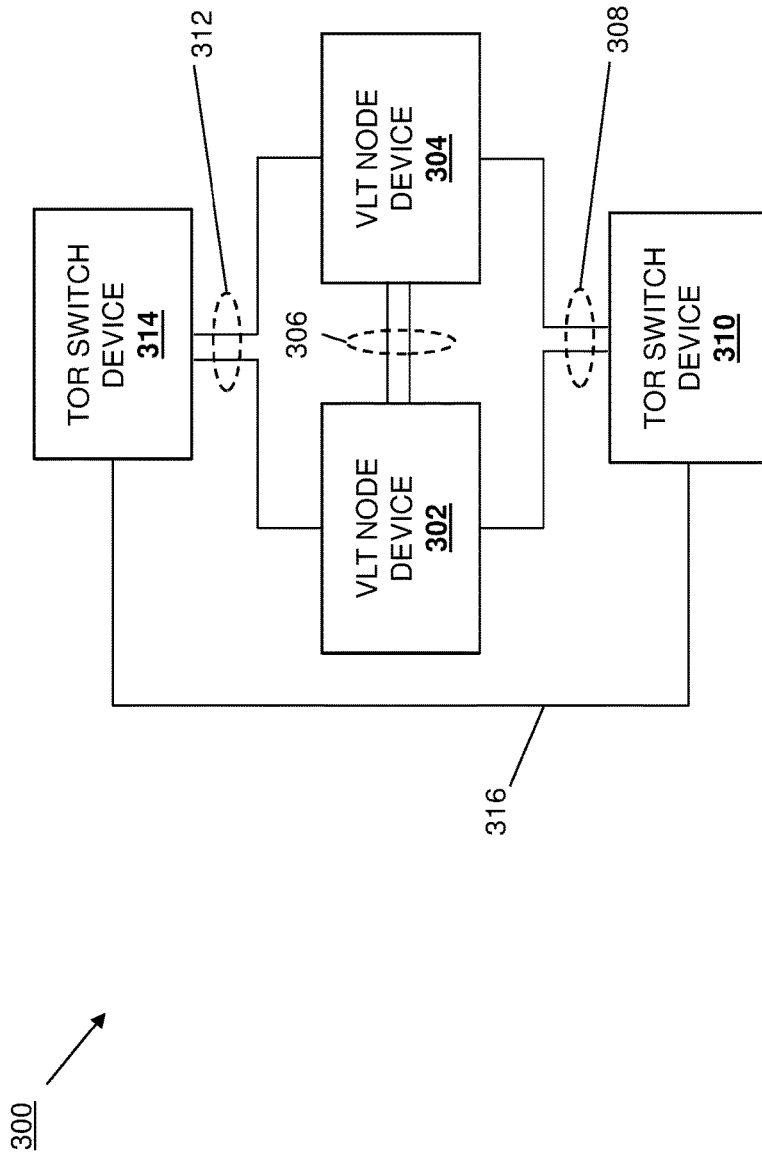

FIG. 3

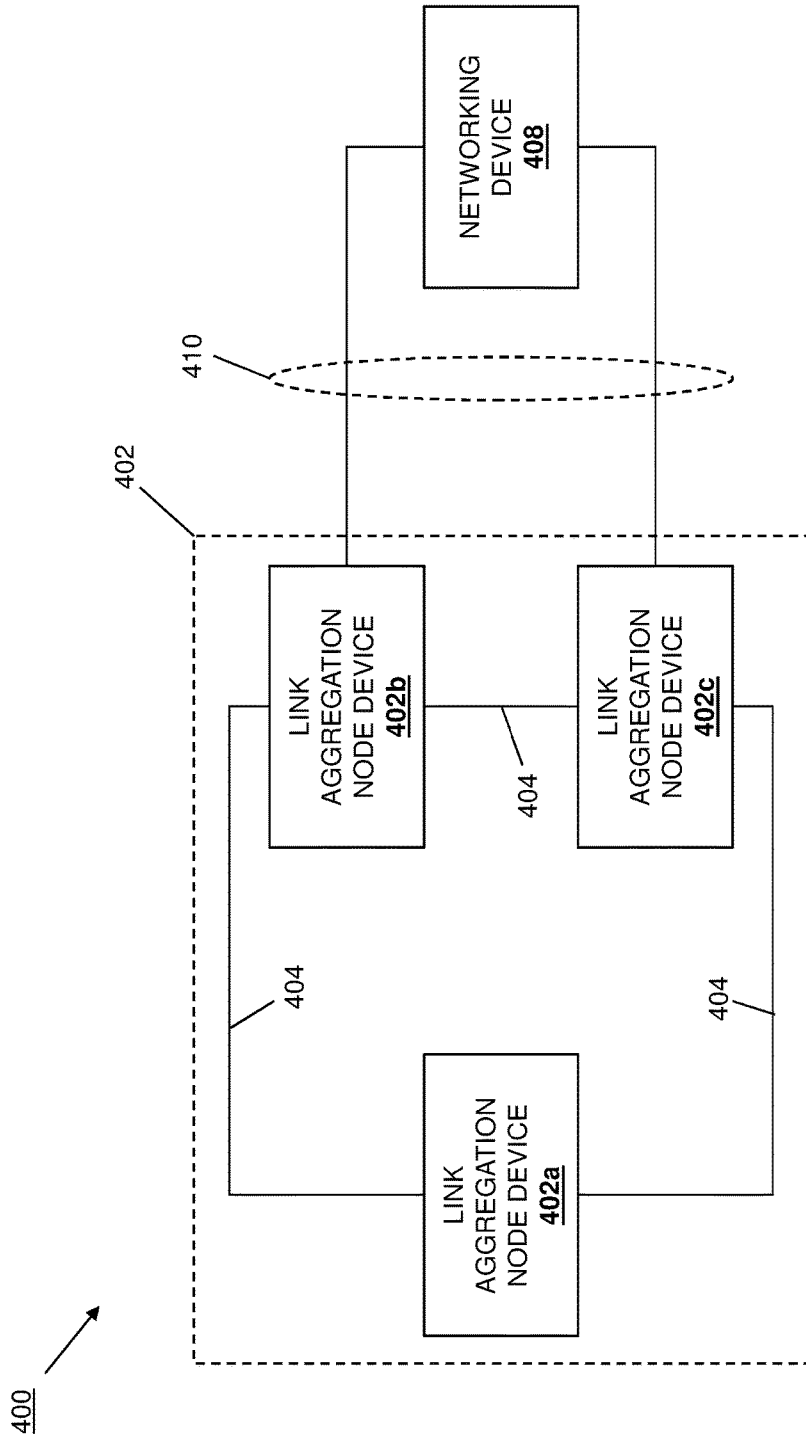

FIG. 4A

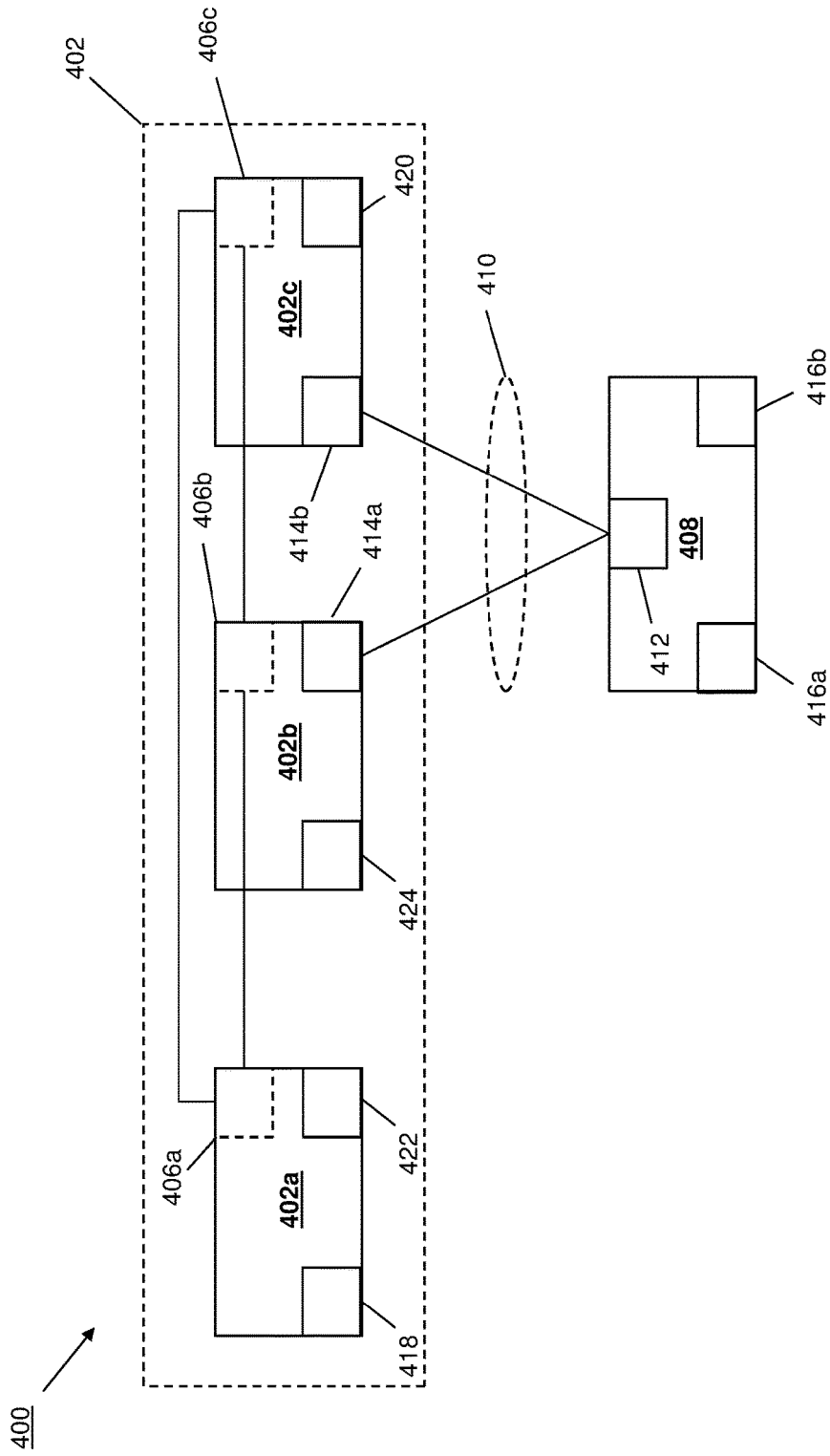

FIG. 4B

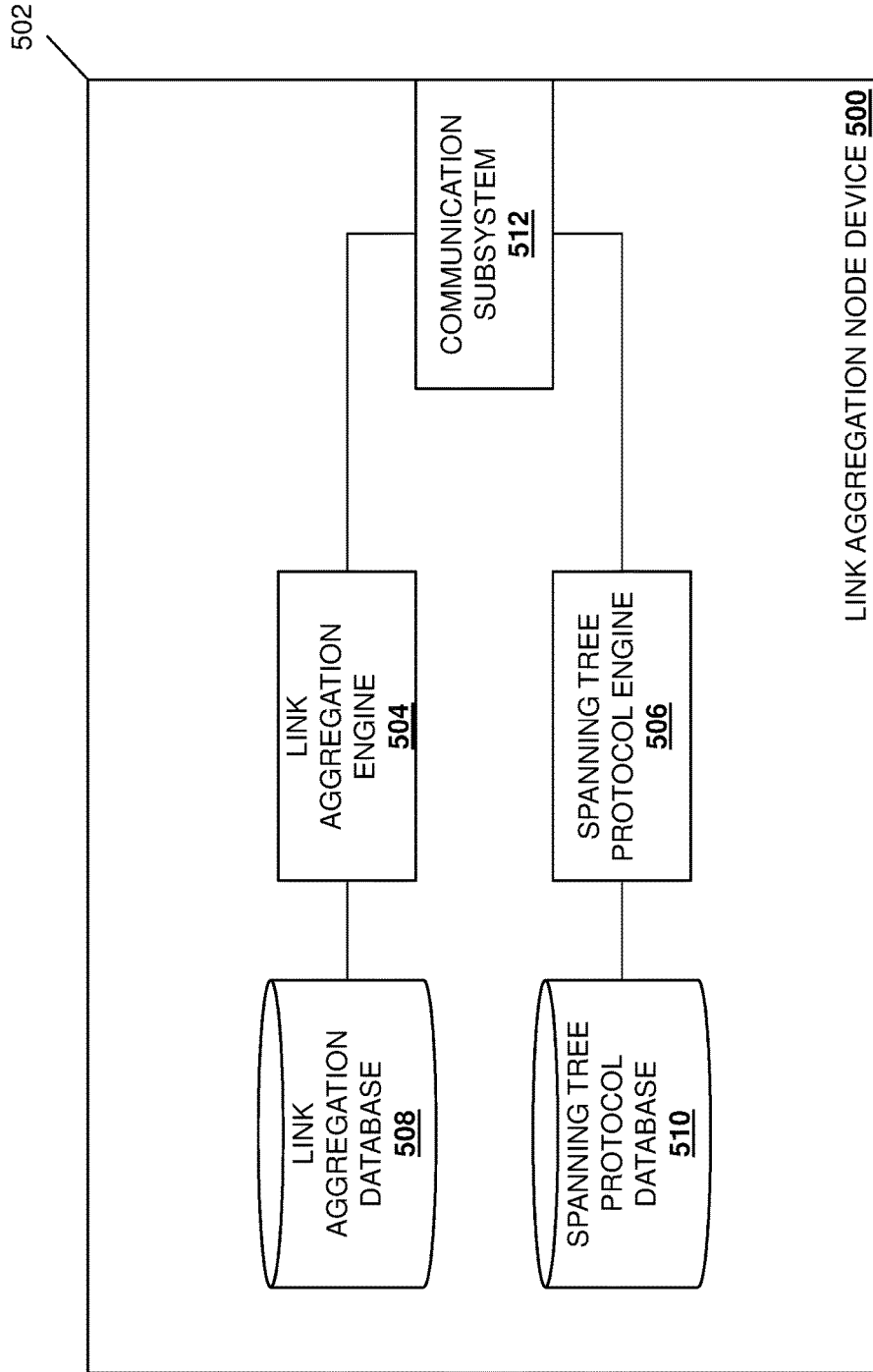

FIG. 5

600 →

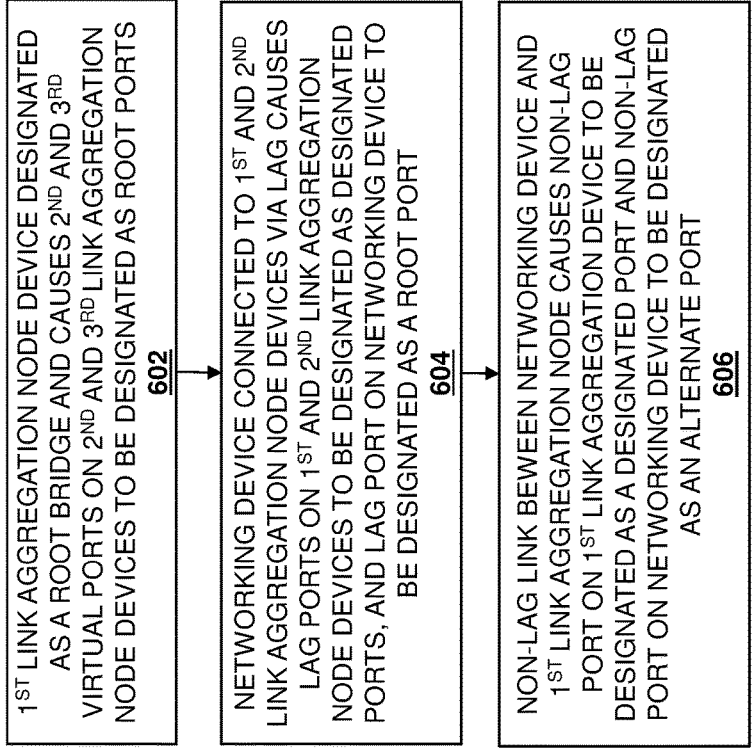

FIG. 6

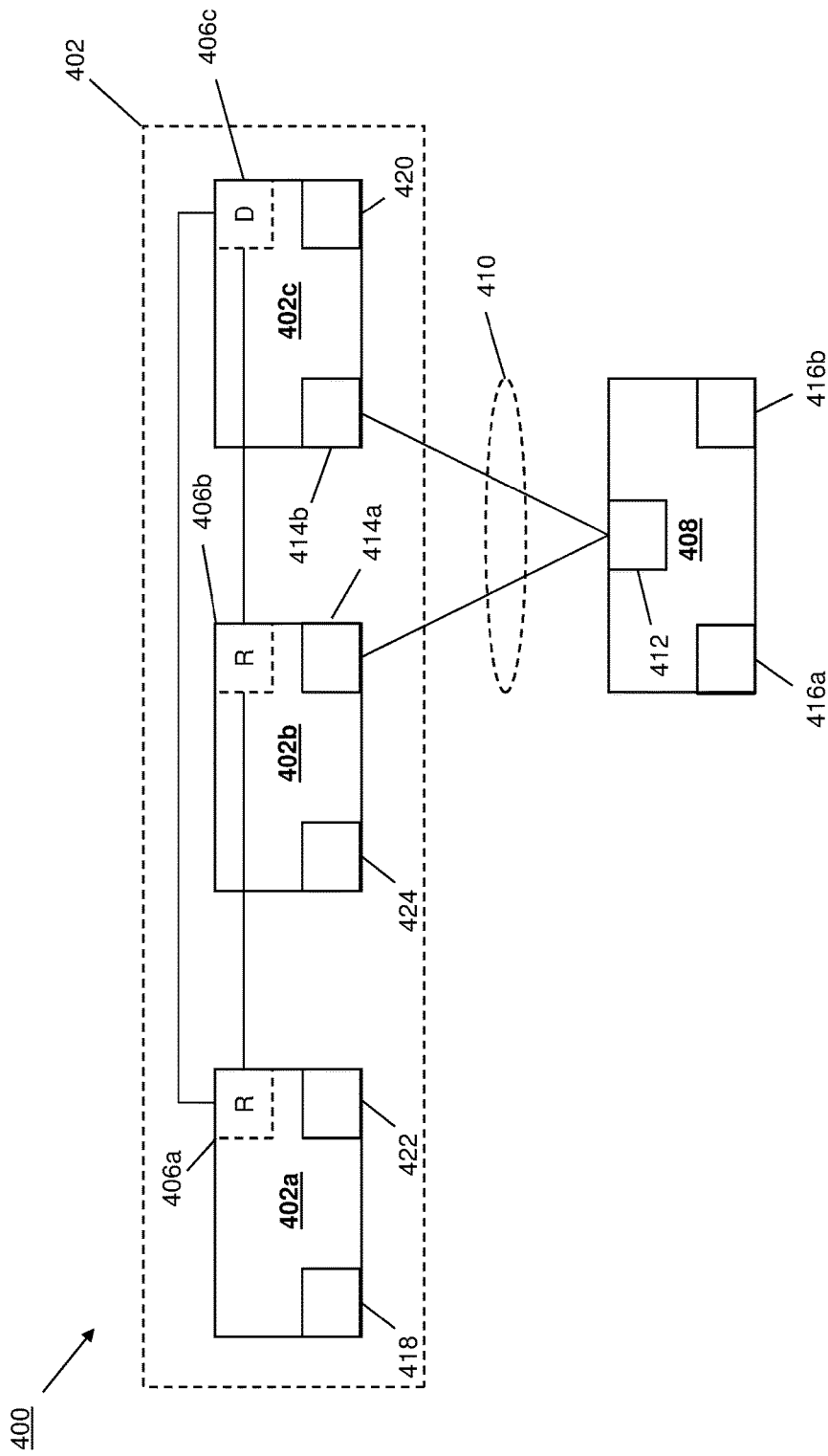

FIG. 7A

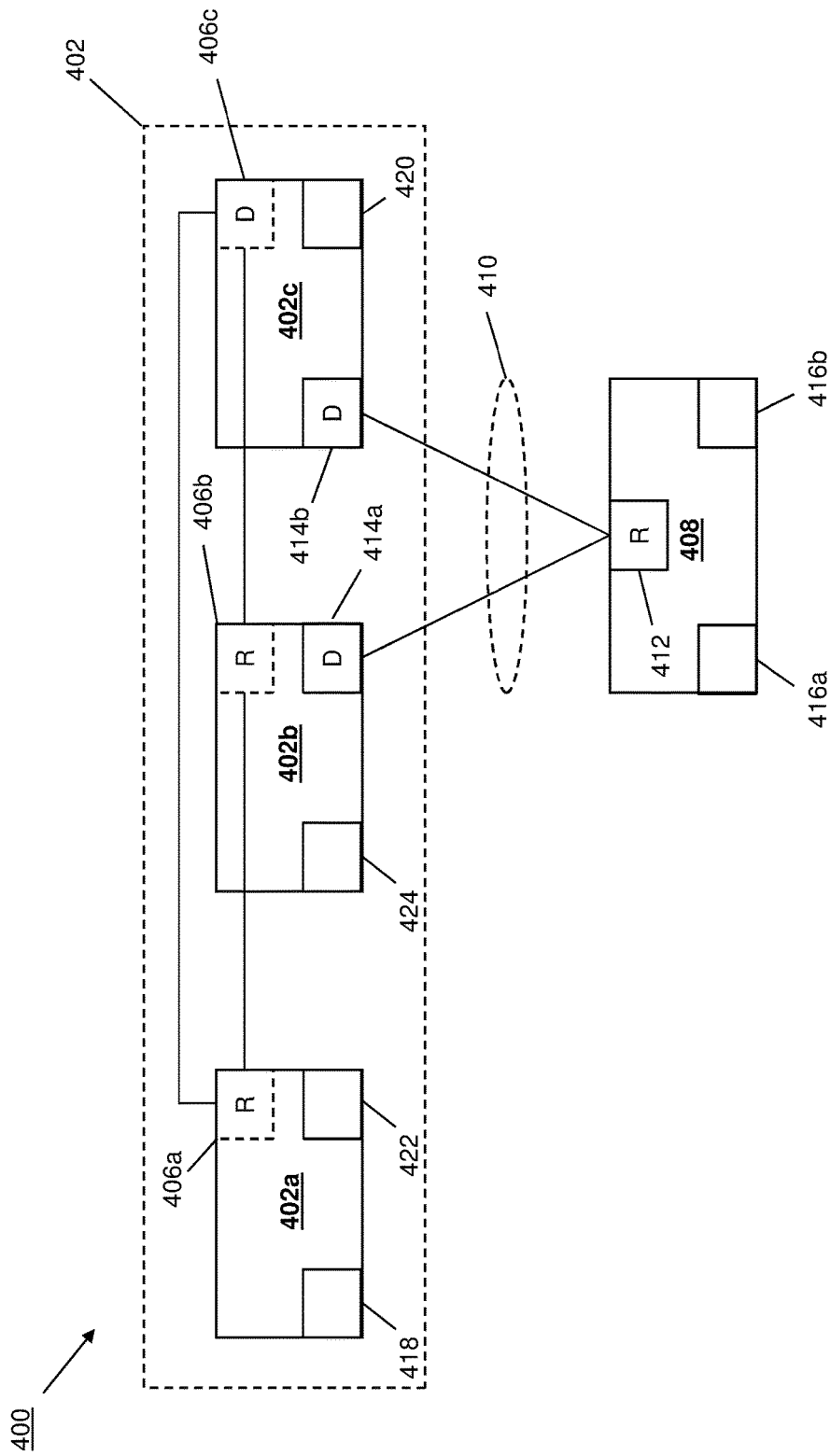

FIG. 7B

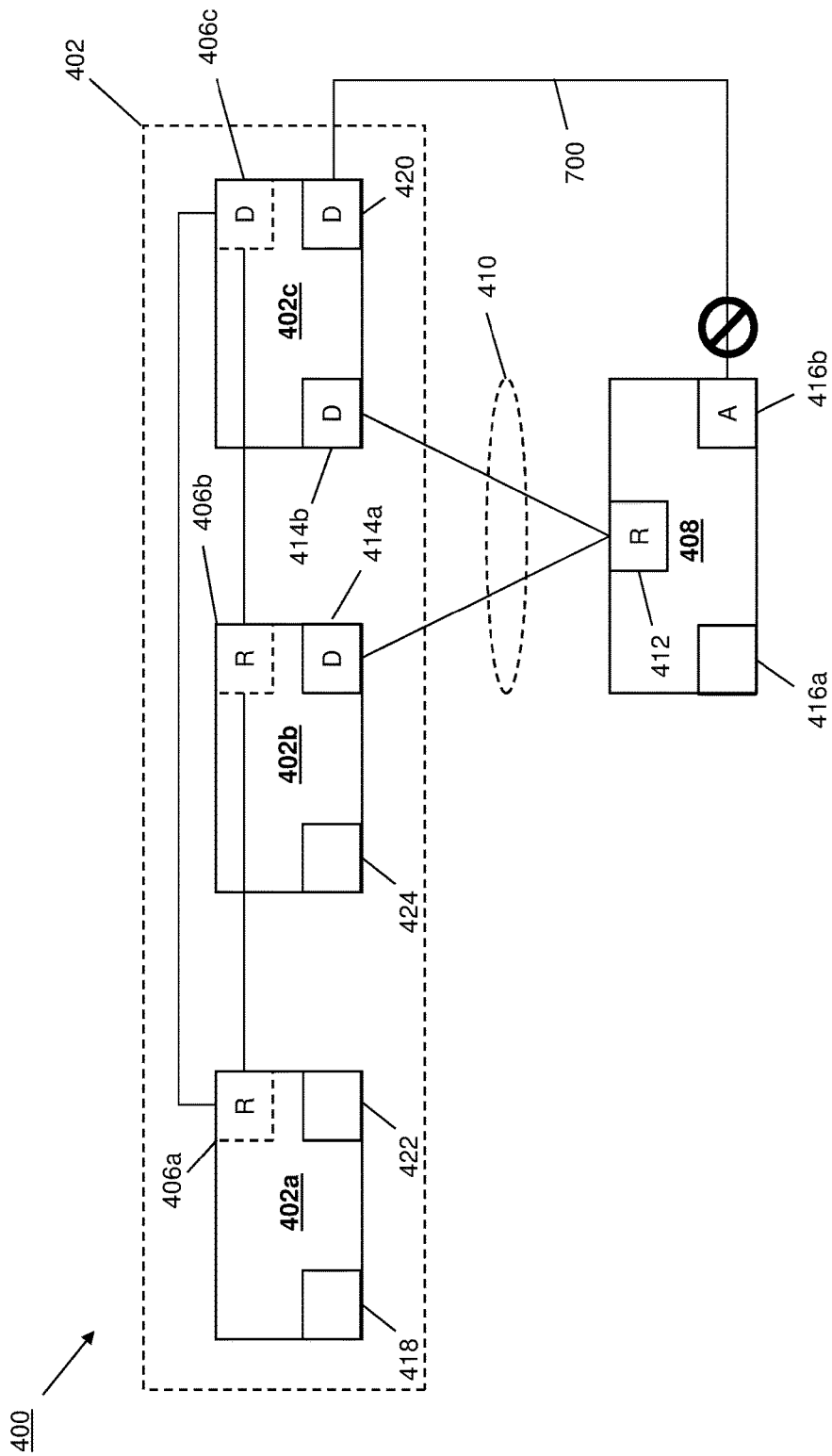

FIG. 7C

800 →

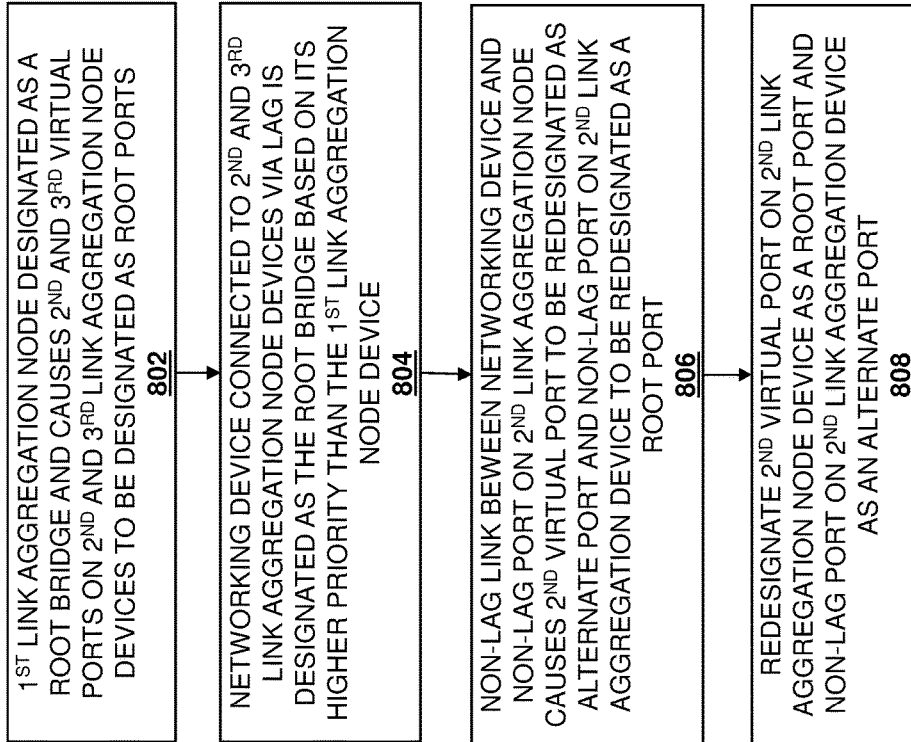

FIG. 8

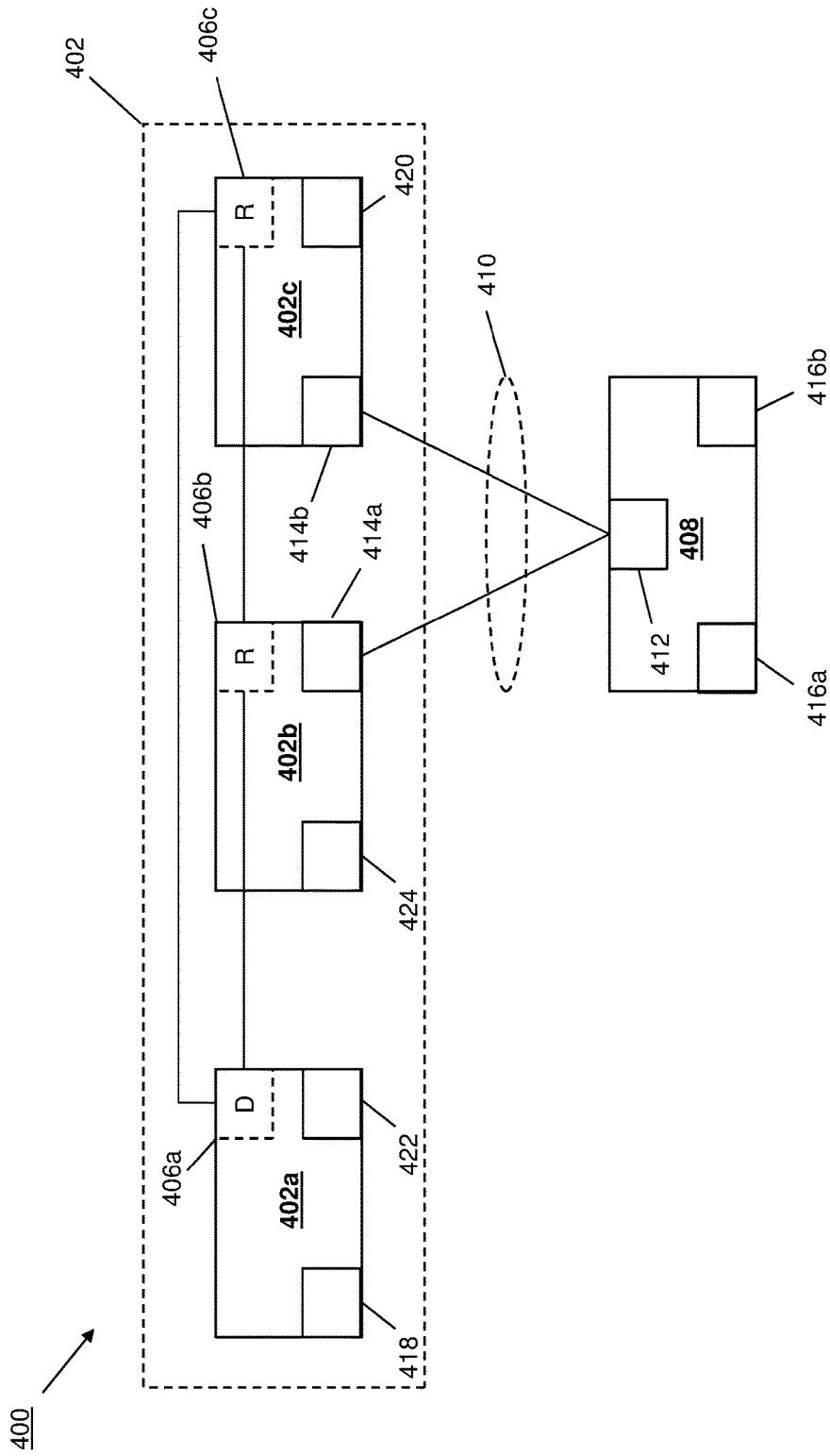

FIG. 9A

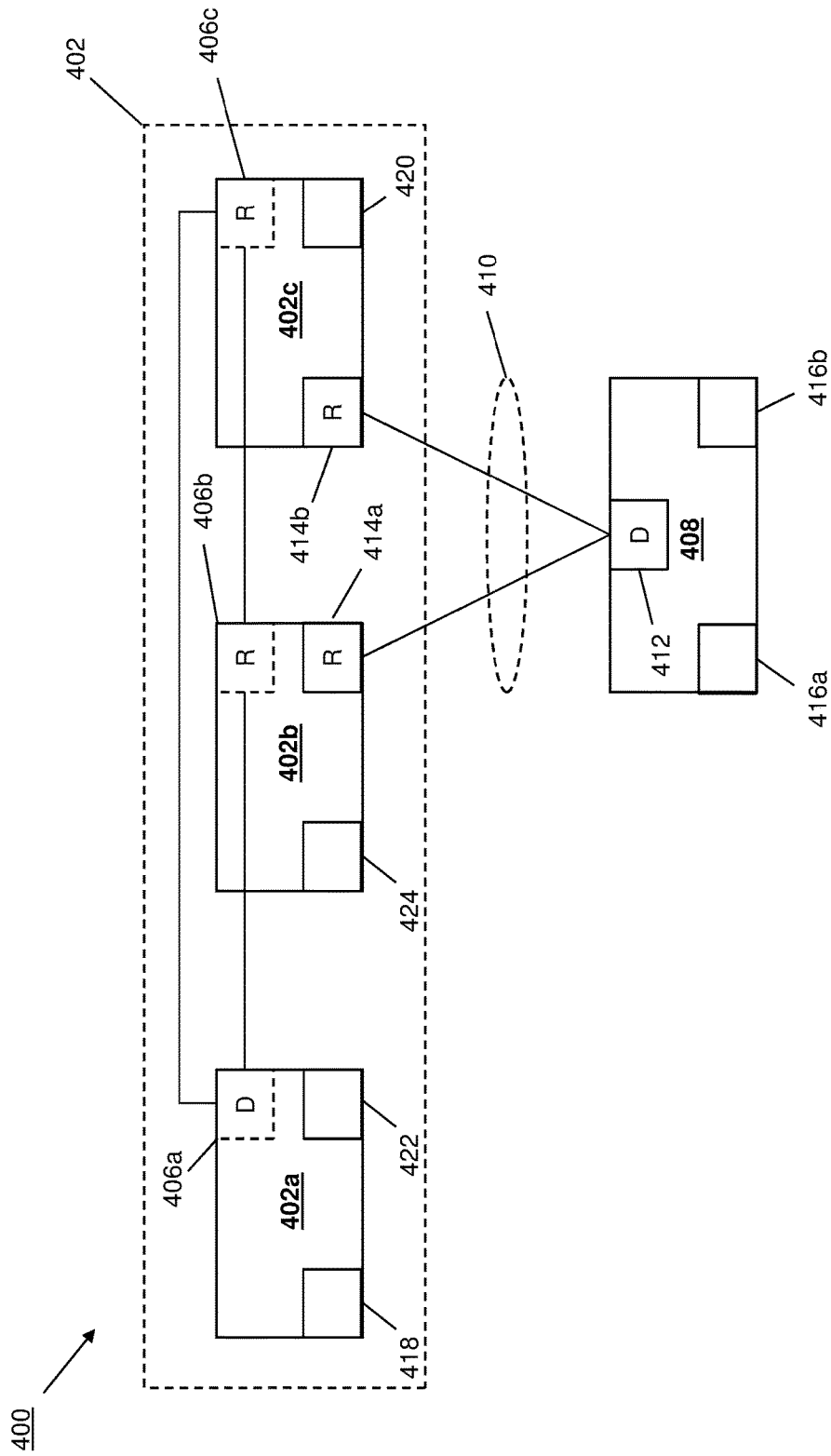

FIG. 9B

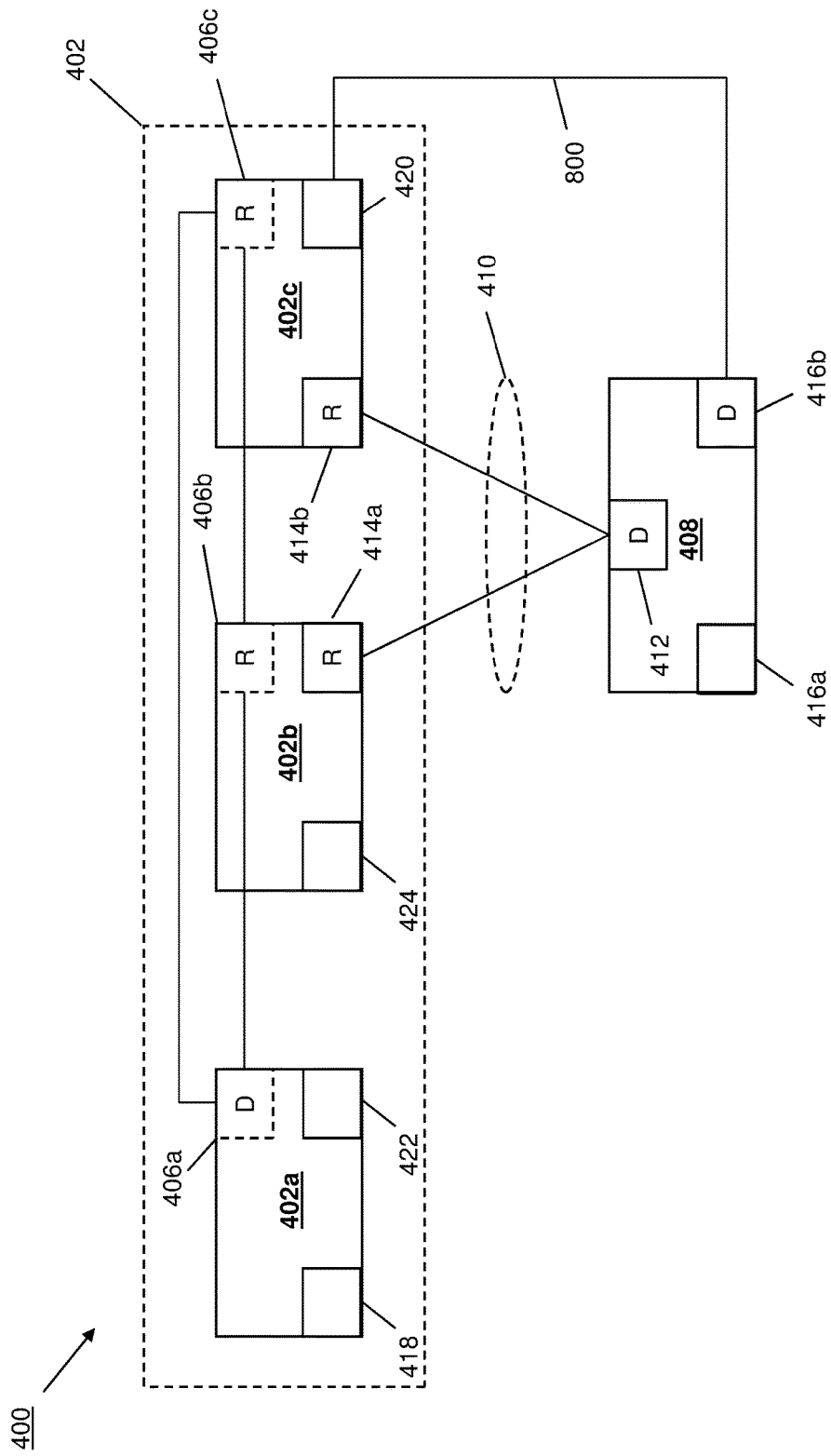

FIG. 9C

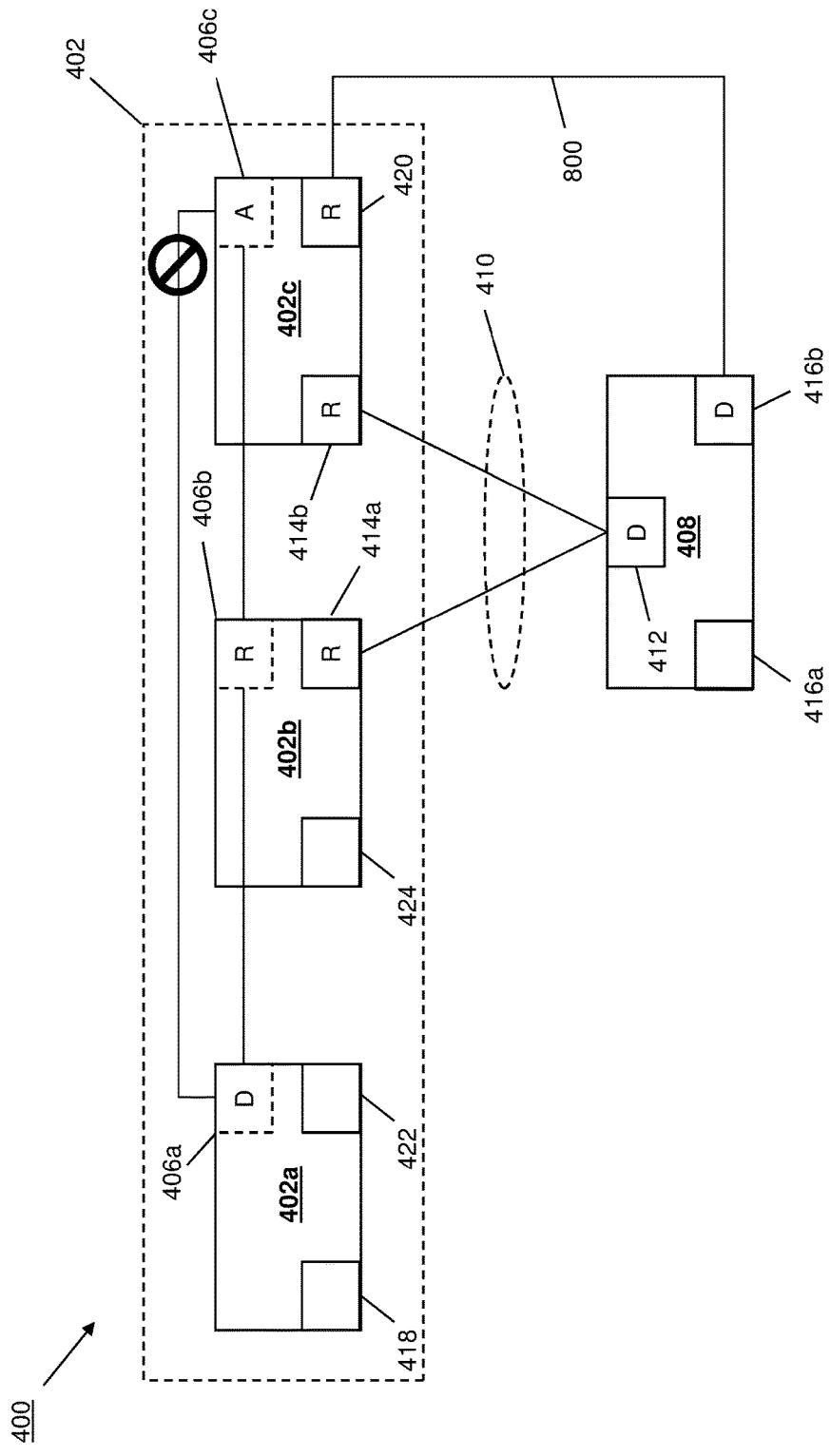

FIG. 9D

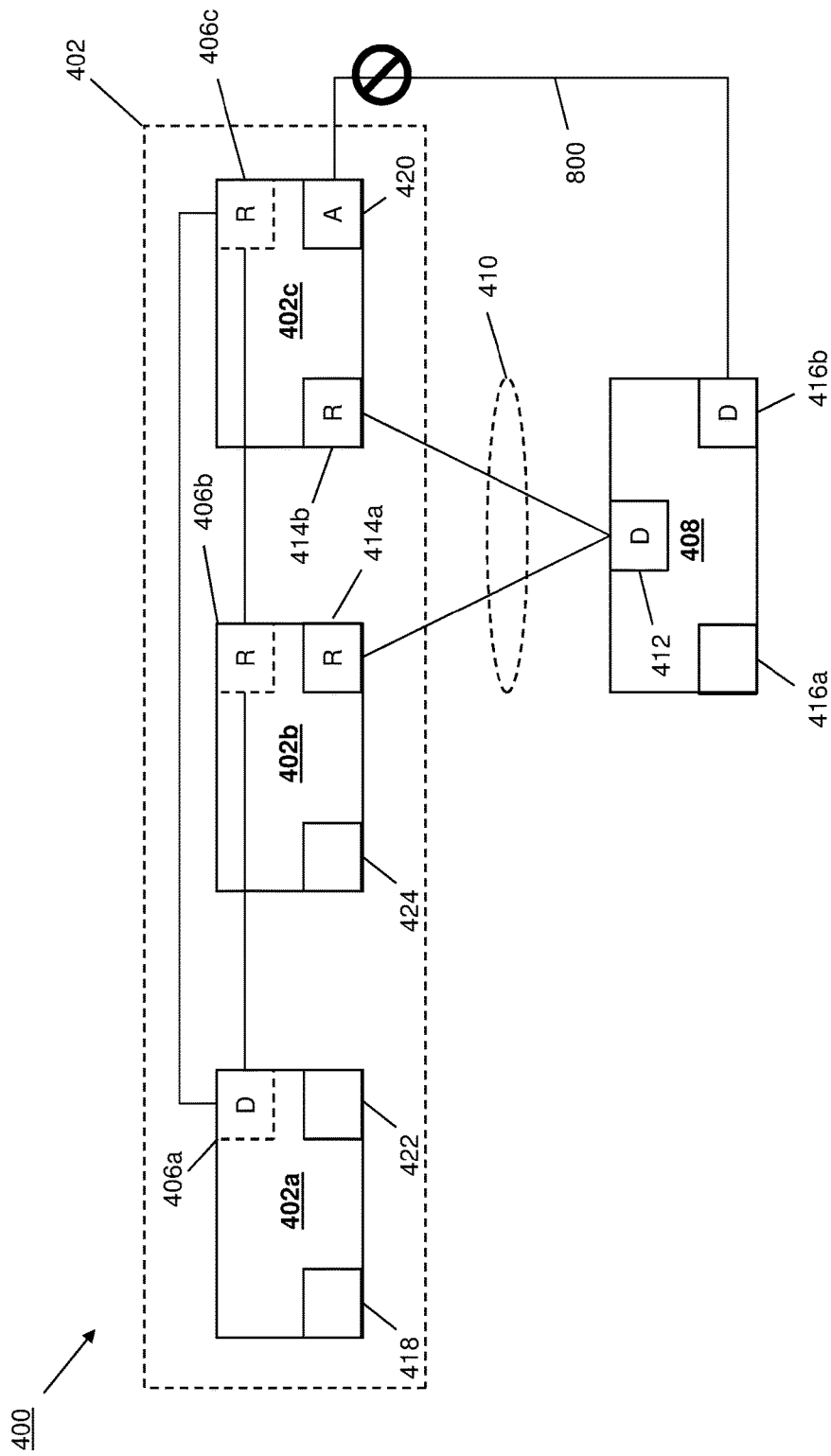

FIG. 9E

1000 ↗

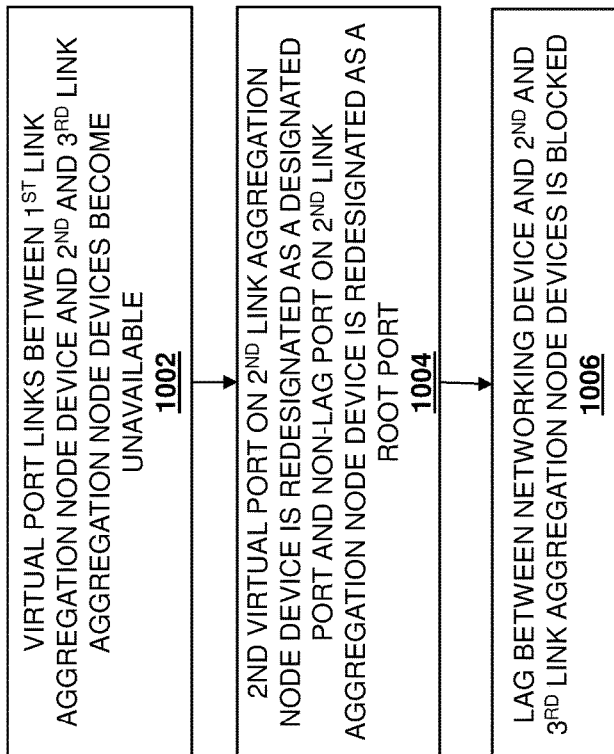

FIG. 10

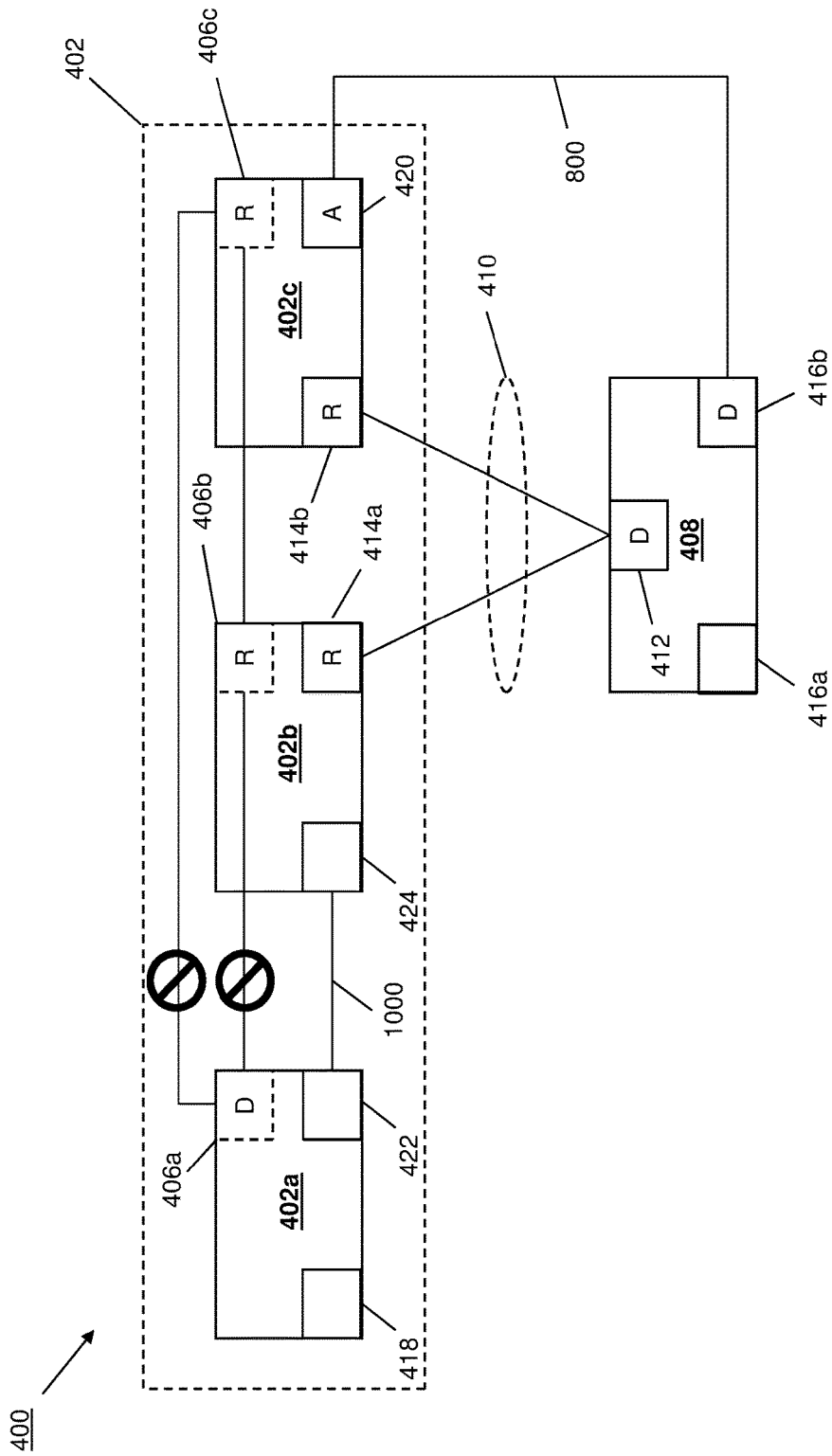

FIG. 11A

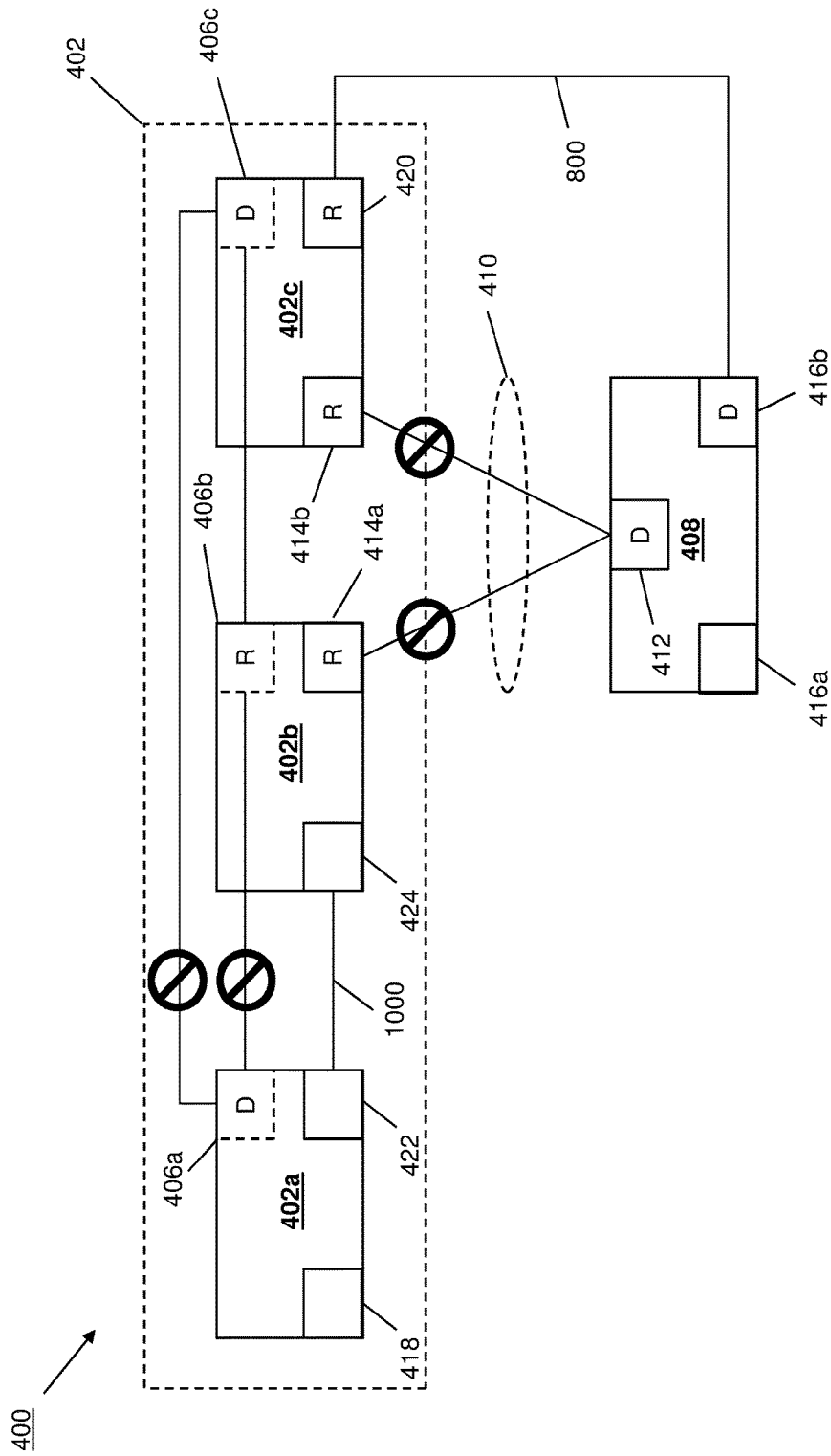

FIG. 11B

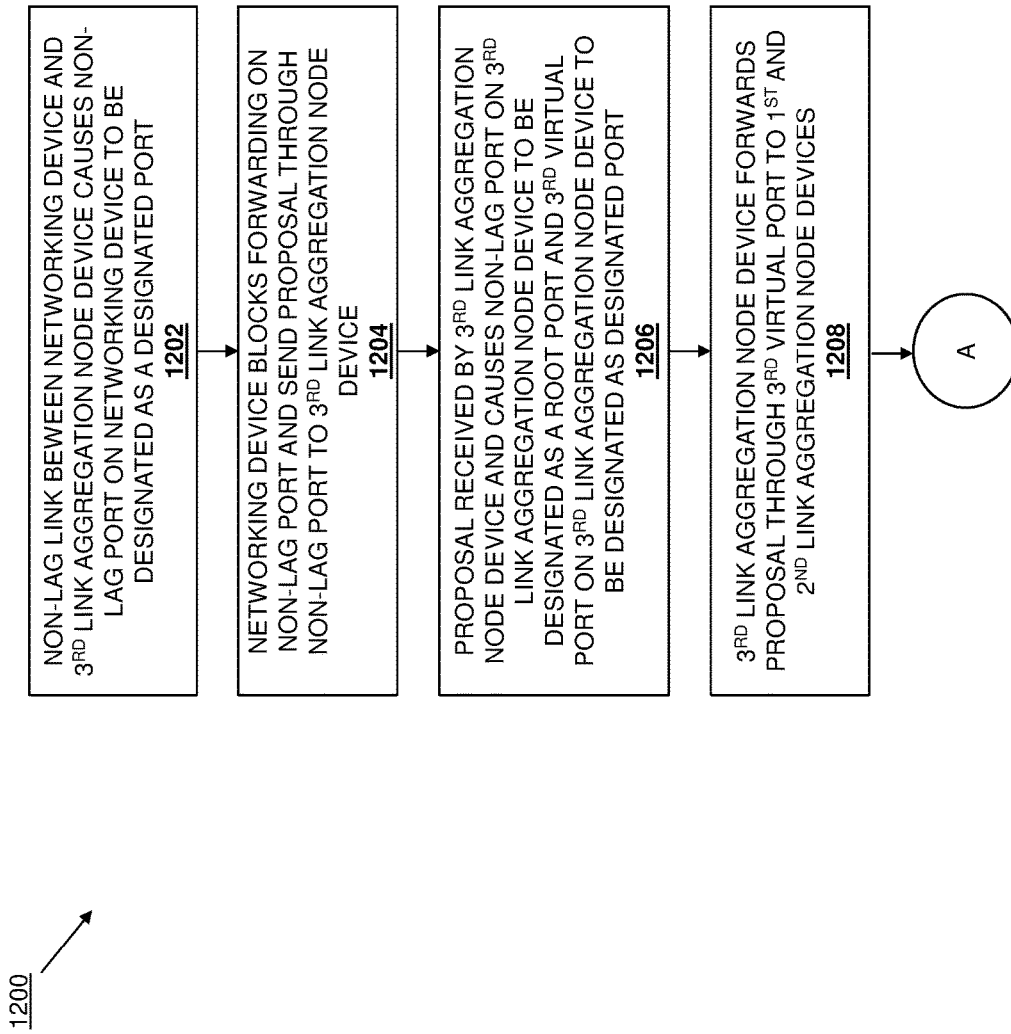

FIG. 12A

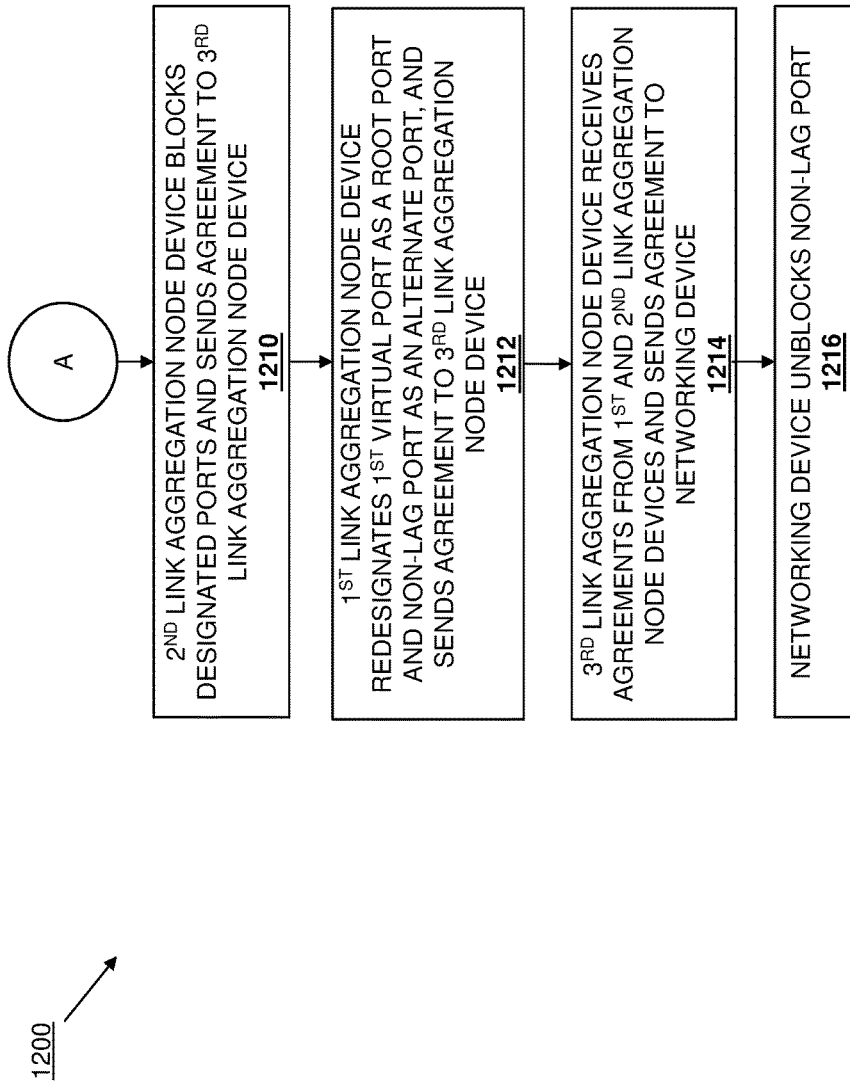

FIG. 12B

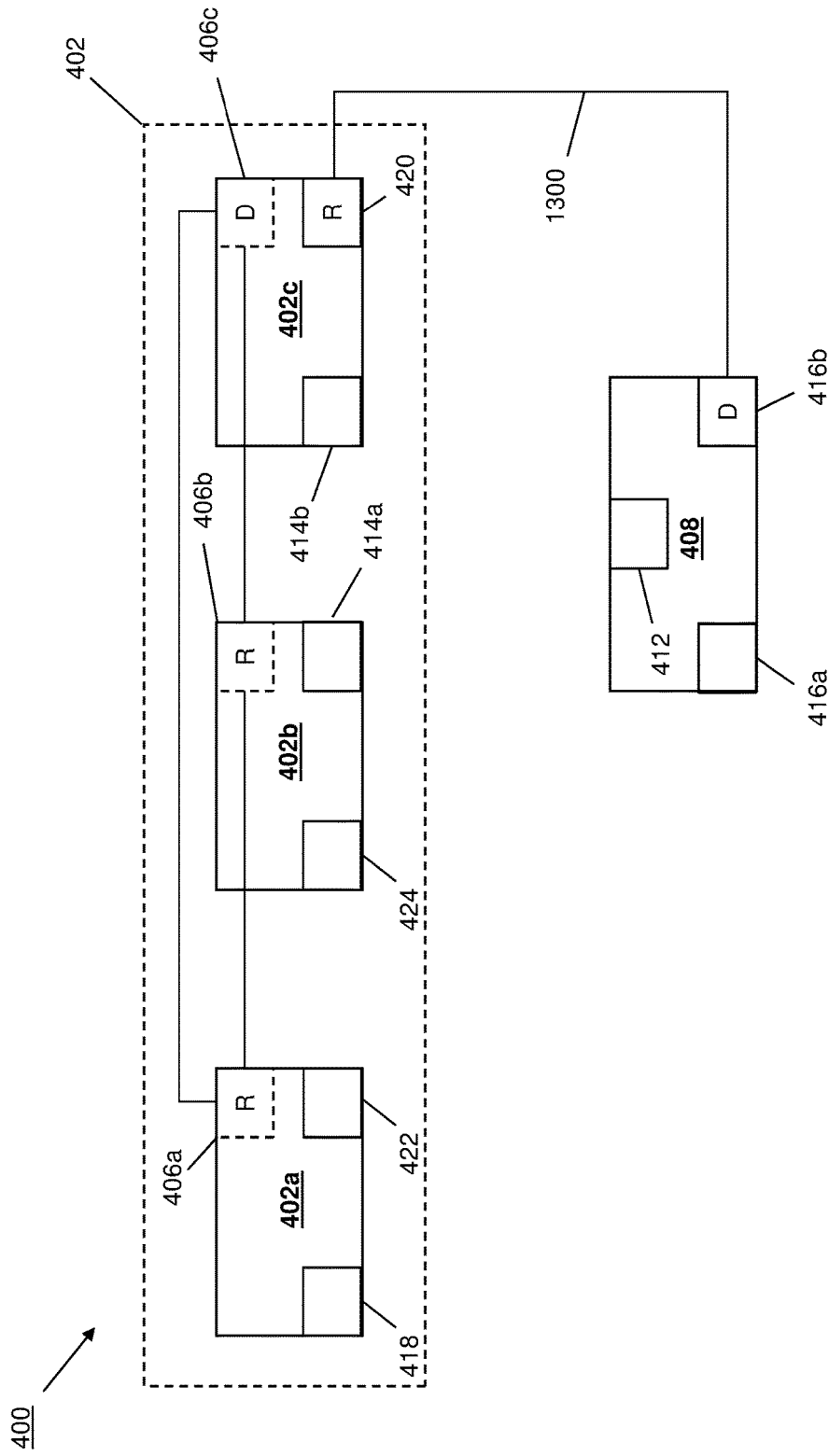

FIG. 13A

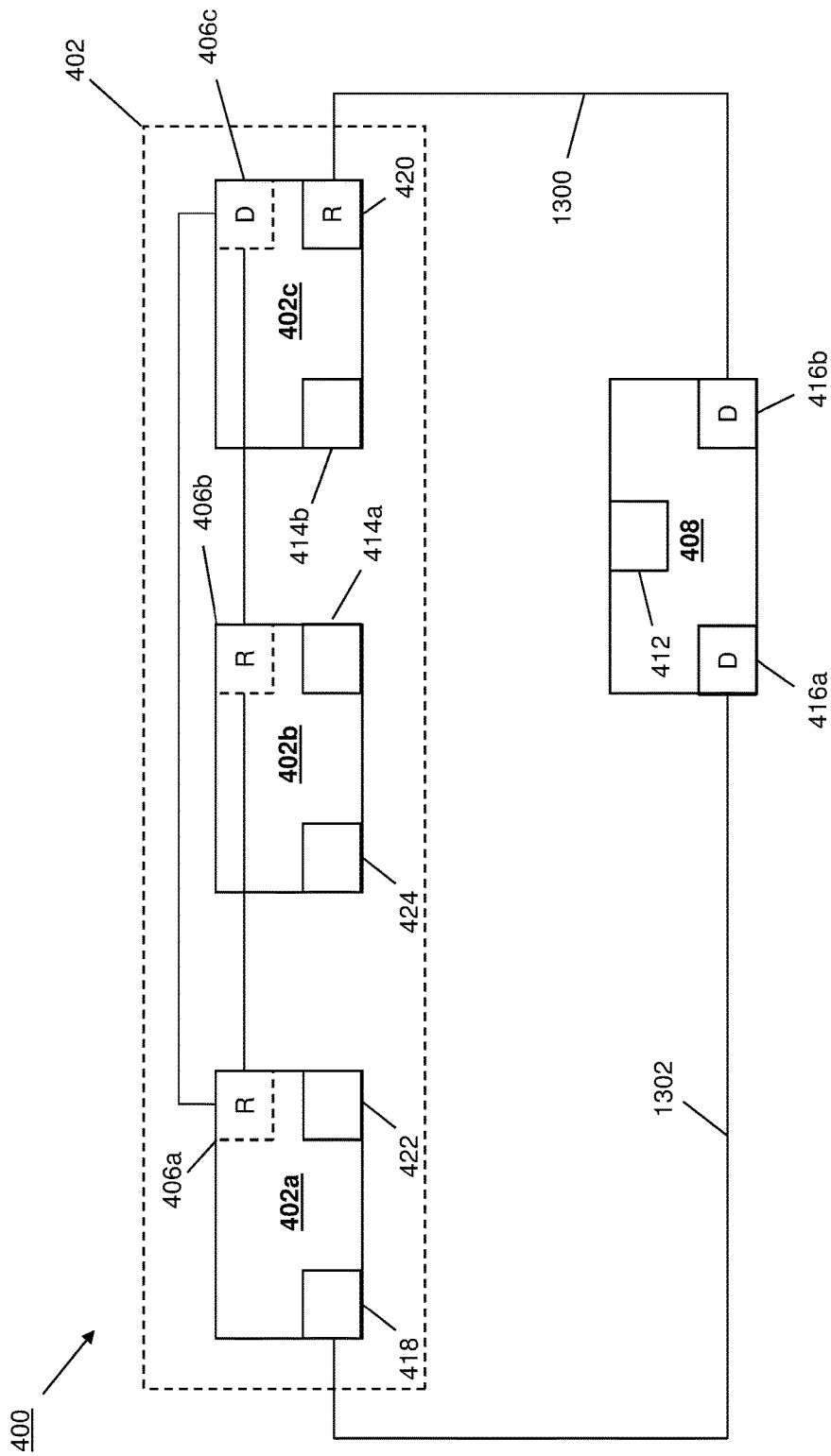

FIG. 13B

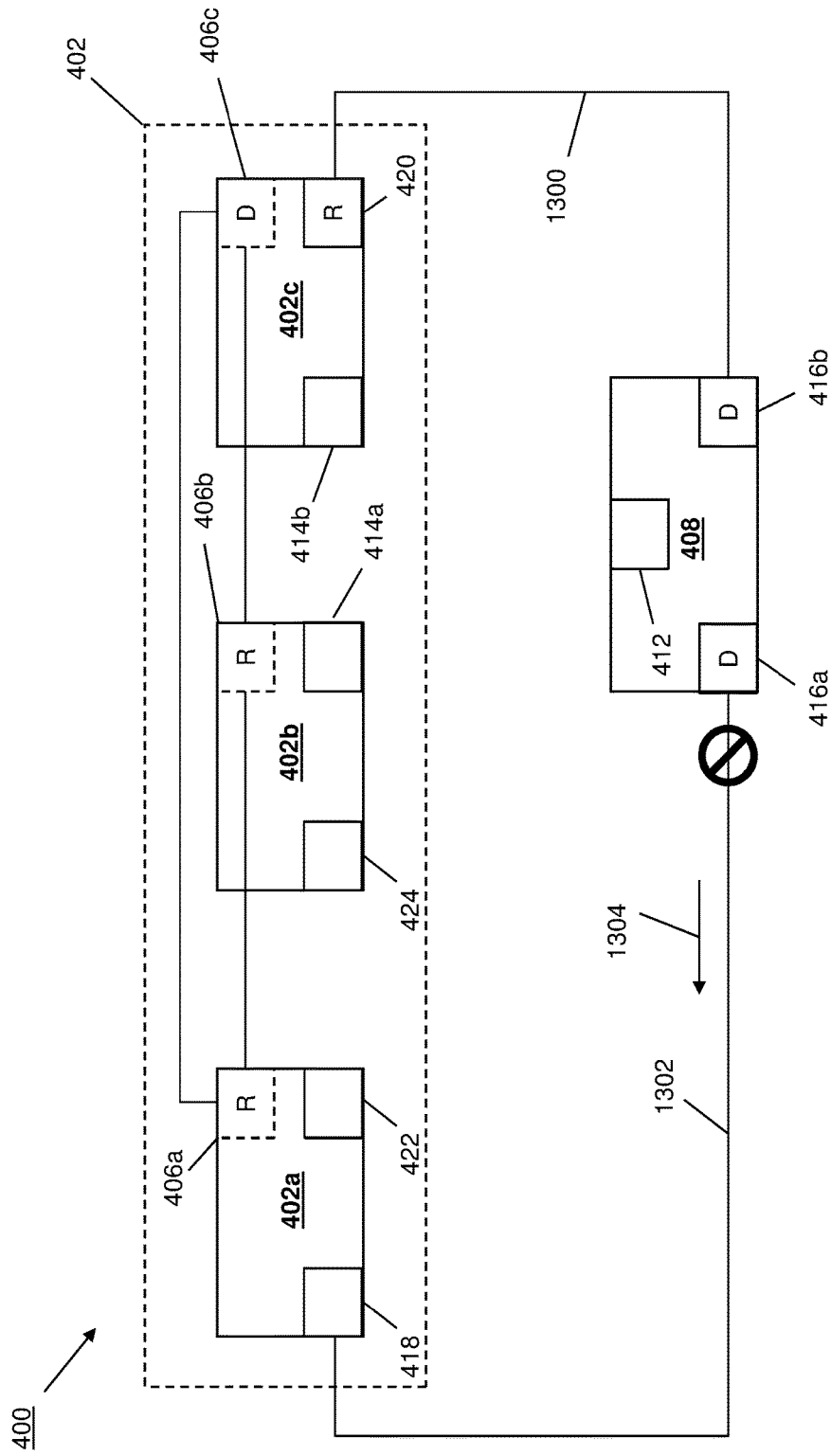

FIG. 13C

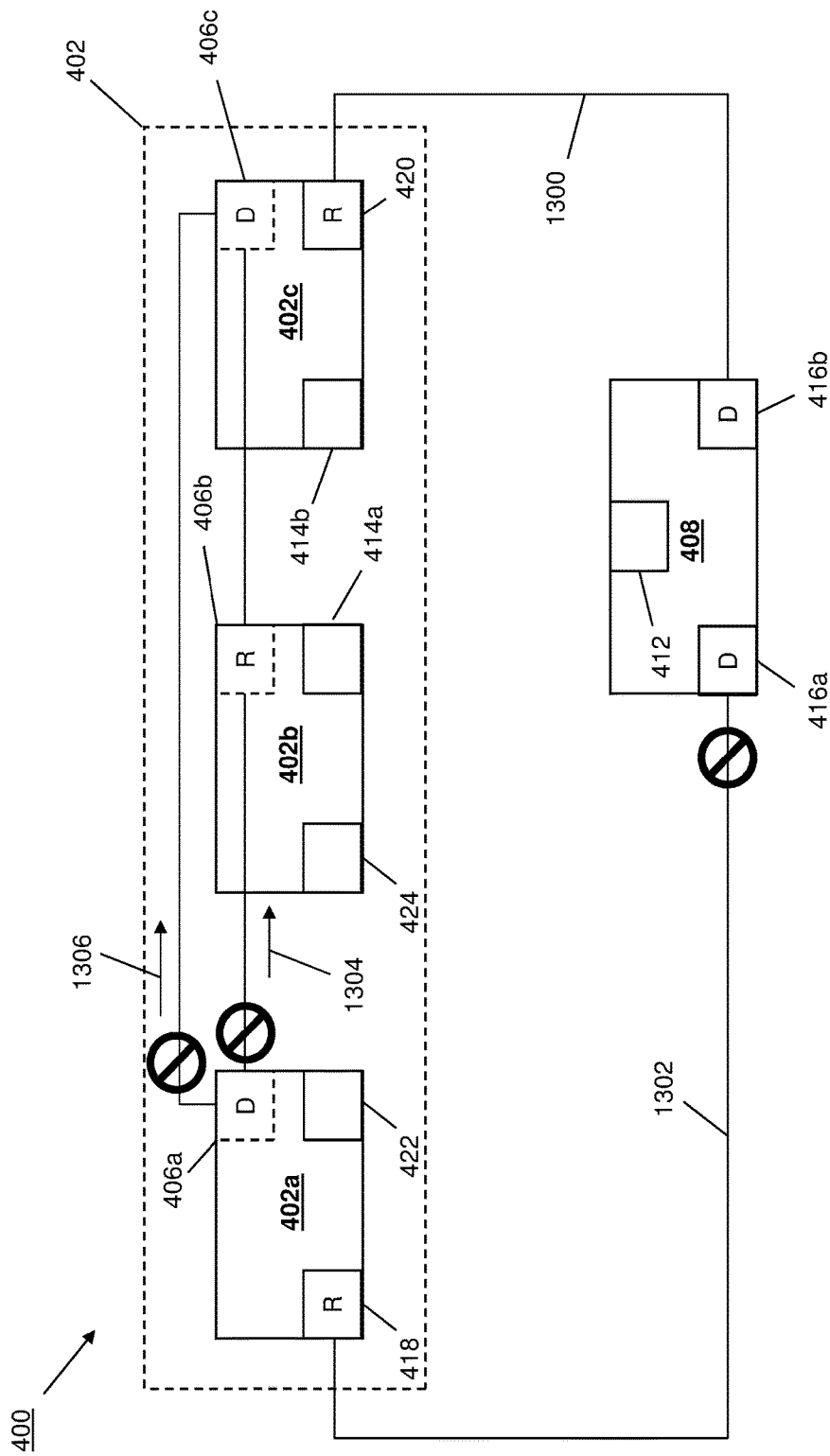

FIG. 13D

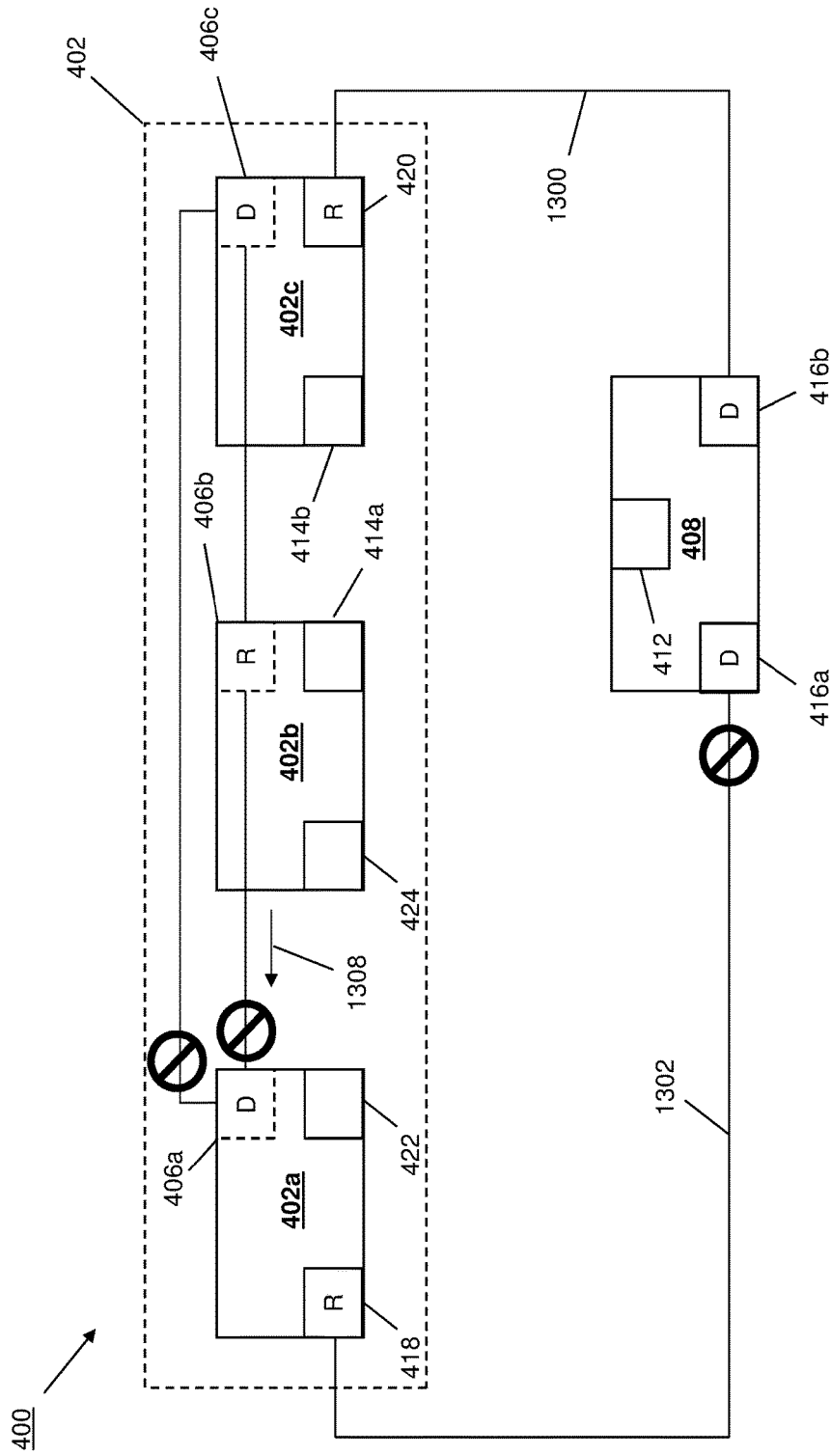

FIG. 13E

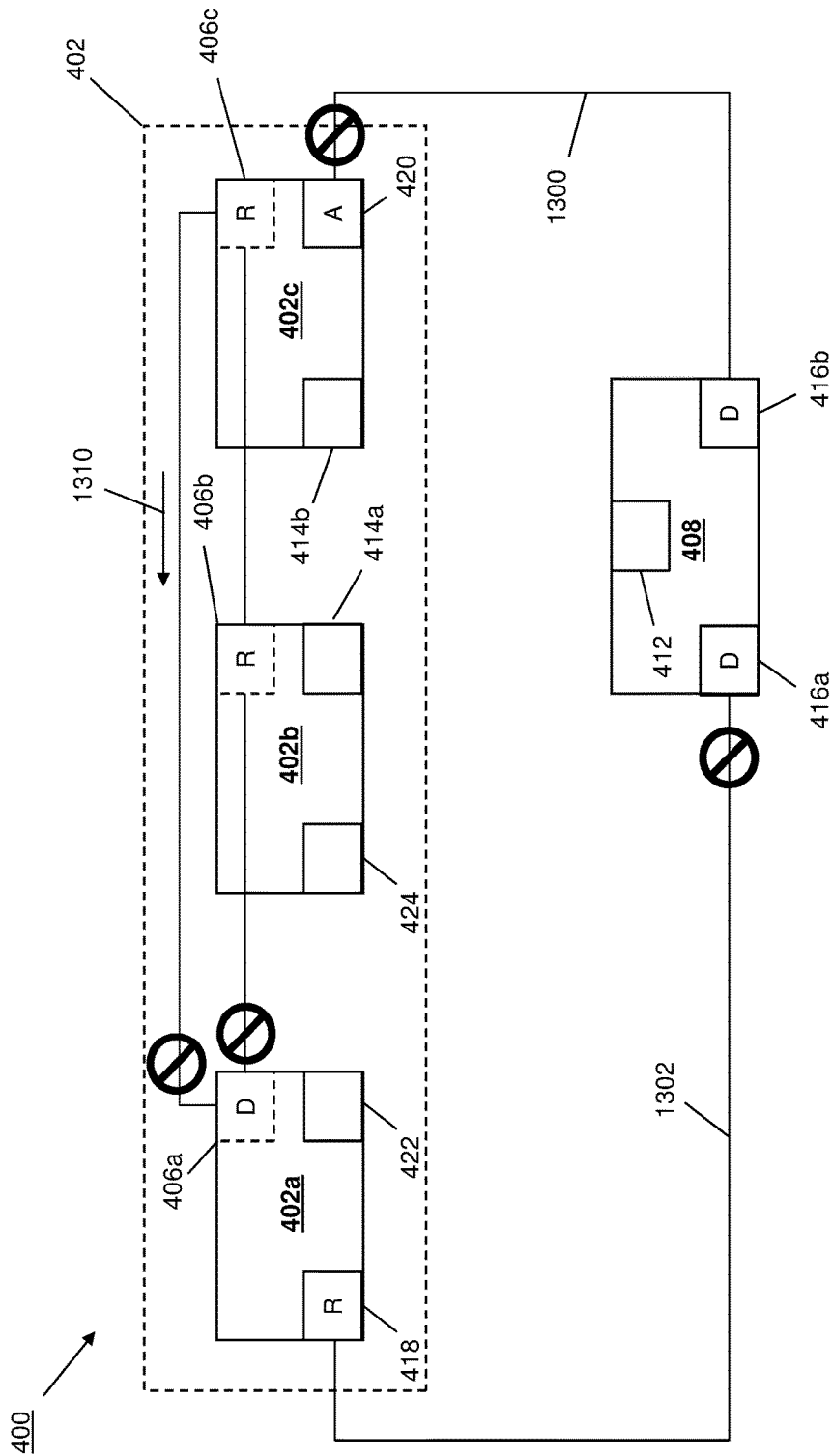

FIG. 13F

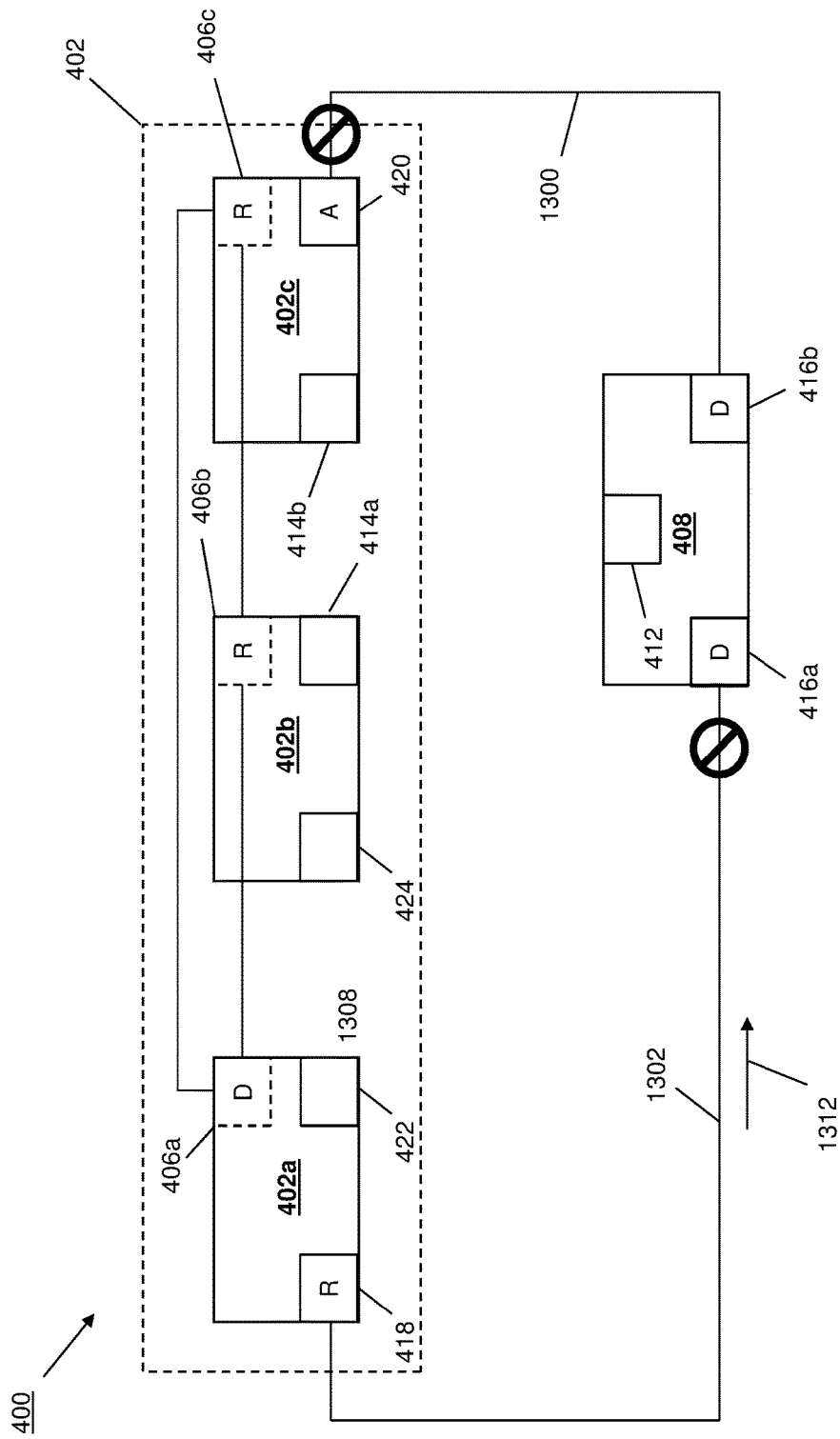

FIG. 13G

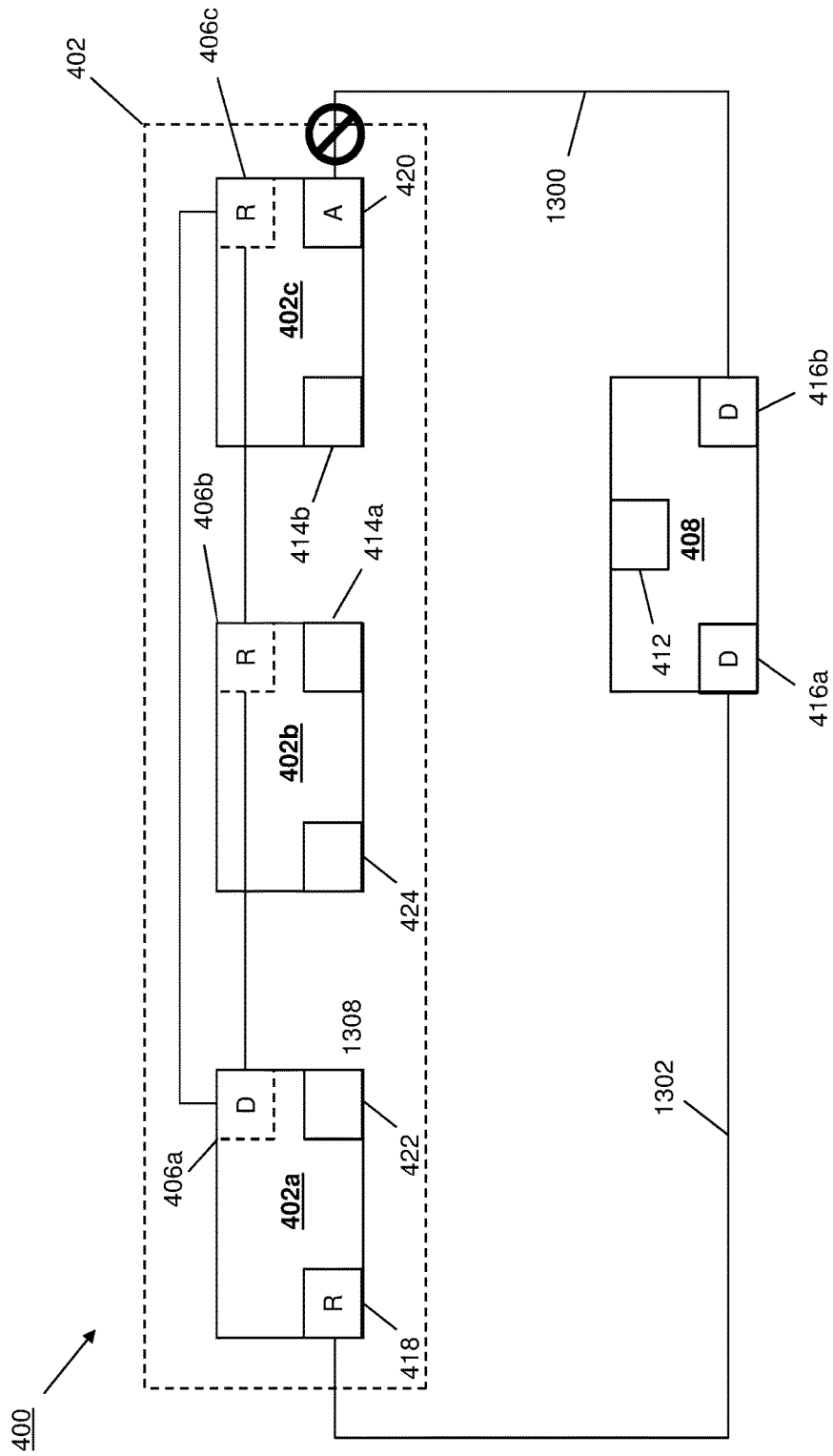

FIG. 13H

SPANNING TREE PROTOCOL ENABLED N-NODE LINK AGGREGATION SYSTEM

BACKGROUND

The present disclosure relates generally to information handling systems, and more particularly to enabling a plurality of link aggregated node devices to run the spanning tree protocol without blocking inter-chassis links between the link aggregated node devices.

As the value and use of information continues to increase, individuals and businesses seek additional ways to process and store information. One option available to users is information handling systems. An information handling system generally processes, compiles, stores, and/or communicates information or data for business, personal, or other purposes thereby allowing users to take advantage of the value of the information. Because technology and information handling needs and requirements vary between different users or applications, information handling systems may also vary regarding what information is handled, how the information is handled, how much information is processed, stored, or communicated, and how quickly and efficiently the information may be processed, stored, or communicated. The variations in information handling systems allow for information handling systems to be general or configured for a specific user or specific use such as financial transaction processing, airline reservations, enterprise data storage, or global communications. In addition, information handling systems may include a variety of hardware and software components that may be configured to process, store, and communicate information and may include one or more computer systems, data storage systems, and networking systems.

Some information handling systems such as switches utilize link aggregation to combine multiple network connections in order to increase throughput, provide redundancy, and/or provide a variety of other link aggregation benefits known in the art. For example, some switches utilize Virtual Link Trunking (VLT), which is a proprietary link aggregation protocol that is provided by the Assignee of the present disclosure and that allows for the setup of an aggregated link to a plurality of different switches. VLT is a layer-2 link aggregation protocol that may be utilized by servers and access switches to, for example, provide a redundant load-balanced connection to the core-network in a loop-free environment, provide uplinks between access switches and core switches, and/or provide a variety of other VLT benefits that would be apparent to one of skill in the art. Conventional VLT provides node level and link level resiliency without the use of the conventional spanning tree protocol, as the use of the conventional spanning tree protocol in place of VLT can result in the blocking of at least a portion of an link between VLT switches, which results in a waste of bandwidth.

However, in some situations, it would be beneficial to block links (as is provided by the conventional spanning tree protocol) to VLT nodes such as the switches discussed above. While VLT nodes generally avoid data loops by forming multi-node link aggregation groups (LAGs), some VLT node configuration can still result in data loops. For example, with reference to the two-node VLT system **200** of FIG. **2**, a pair of VLT node devices **202** and **204** may be connected to each other by an Inter-Chassis Link (ICL) **206** (also known as VLT interconnects VLTi's), and may each be part of a VLT LAG **208** to a Top Of Rack (TOR) switch device **210** that is also connected to the VLT node device

202 by a link **212**. In another example, with reference to the two-node VLT system **300** of FIG. **3**, a pair of VLT node devices **302** and **304** may be connected to each other by an ICL **306**, and may each be part of a first VLT LAG **308** to a TOR switch device **310**, as well as part of a second VLT LAG **312** to a TOR switch device **314** that is also connected to the TOR switch **310** by a link **316**. One of skill in the art in possession of the present disclosure will recognize how the configurations of the two-node VLT systems **200** and **300**, as well as the n-node VLT system discussed below with reference to FIG. **4**, may result in data loops (e.g., via a data loop provided by the ICL **206**, the VLT LAG **208**, and the link **212** in FIG. **2**.)

N-node VLT systems can support any arbitrary topology (e.g., star topologies, ring topologies, mesh topologies, etc.) for a VLT fabric that includes VLT nodes connected by ICLs. In such n-node VLT systems, a VLT fabric manager may run an ICL loop prevention algorithm and install any appropriate forwarding rules to break loops in the VLT fabric without blocking any of the ICLs between the VLT nodes. However, if the conventional spanning tree protocol is run on such an n-node VLT system, it may operate to block ICLs between VLT nodes. Furthermore, the conventional spanning tree protocol may also block ICLs between the VLT nodes even when there is no data loop in the VLT fabric (i.e., in the VLT nodes connected by ICLs), as if the ICL is part of a data loop (e.g., the ICL **206** that is part of a data loop that includes the VLT lag **208** and the link **212** in FIG. **2**), the conventional spanning tree protocol may operate to block that ICL to avoid the data loop. Solving these and other issues would enable the use of the spanning tree protocol to block links in an n-node VLT system in order to address data loops that arise in some VLT node configurations.

Accordingly, it would be desirable to provide a spanning tree enabled n-node link aggregation system.

SUMMARY

According to one embodiment, an Information Handling System (IHS) includes a communication subsystem that provides a Link Aggregation Group (LAG) port, a non-LAG port, and a first virtual port; a processing system that is coupled to the communication subsystem, and a memory system that is coupled to the processing system and that includes instructions that, when executed by the processing system, cause the processing system to provide a spanning tree protocol engine that is configured to: determine that a link aggregation node device including a second virtual port coupled to the first virtual port has been designated as a root bridge and, in response, designate the first virtual port as a root port; determine that a networking device that is coupled to the LAG port has a higher priority than the first link aggregation node device and has been designated as the root bridge; and determine that a non-LAG link provided between the networking device and the non-LAG port has caused the first virtual port to be redesignated as an alternate port and the non-LAG port to be designated as a root port and, in response, redesignate the first virtual port as a root port and redesignate the non-LAG port as an alternate port.

BRIEF DESCRIPTION OF THE DRAWINGS

FIG. **1** is a schematic view illustrating an embodiment of an information handling system.

FIG. **2** is a schematic view of an embodiment of a two-node VLT system.

3

FIG. 3 is a schematic view of an embodiment of a two-node VLT system.

FIG. 4A is a schematic view of an embodiment of an n-node link aggregation system.

FIG. 4B is a schematic view of the n-node link aggregation system of FIG. 4A that identifies ports on the devices.

FIG. 5 is a schematic view illustrating an embodiment of a link aggregation node device used in the n-node link aggregation system of FIGS. 4A and 4B.

FIG. 6 is a flow chart illustrating an embodiment of a method for enabling the spanning tree protocol in an n-node link aggregation system.

FIG. 7A is a schematic view illustrating an embodiment of the n-node link aggregation system of FIG. 4B during the method of FIG. 6.

FIG. 7B is a schematic view illustrating an embodiment of the n-node link aggregation system of FIG. 4B during the method of FIG. 6.

FIG. 7C is a schematic view illustrating an embodiment of the n-node link aggregation system of FIG. 4B during the method of FIG. 6.

FIG. 8 is a flow chart illustrating an embodiment of a method for enabling the spanning tree protocol in an n-node link aggregation system.

FIG. 9A is a schematic view illustrating an embodiment of the n-node link aggregation system of FIG. 4B during the method of FIG. 8.

FIG. 9B is a schematic view illustrating an embodiment of the n-node link aggregation system of FIG. 4B during the method of FIG. 8.

FIG. 9C is a schematic view illustrating an embodiment of the n-node link aggregation system of FIG. 4B during the method of FIG. 8.

FIG. 9D is a schematic view illustrating an embodiment of the n-node link aggregation system of FIG. 4B during the method of FIG. 8.

FIG. 9E is a schematic view illustrating an embodiment of the n-node link aggregation system of FIG. 4B during the method of FIG. 8.

FIG. 10 is a flow chart illustrating an embodiment of a method for enabling the spanning tree protocol in an n-node link aggregation system.

FIG. 11A is a schematic view illustrating an embodiment of the n-node link aggregation system of FIG. 4B during the method of FIG. 10.

FIG. 11B is a schematic view illustrating an embodiment of the n-node link aggregation system of FIG. 4B during the method of FIG. 10.

FIGS. 12A and 12B are a flow chart illustrating an embodiment of a method for enabling the spanning tree protocol in an n-node link aggregation system.

FIG. 13A is a schematic view illustrating an embodiment of the n-node link aggregation system of FIG. 4B during the method of FIGS. 12A and 12B.

FIG. 13B is a schematic view illustrating an embodiment of the n-node link aggregation system of FIG. 4B during the method of FIGS. 12A and 12B.

FIG. 13C is a schematic view illustrating an embodiment of the n-node link aggregation system of FIG. 4B during the method of FIGS. 12A and 12B.

FIG. 13D is a schematic view illustrating an embodiment of the n-node link aggregation system of FIG. 4B during the method of FIGS. 12A and 12B.

FIG. 13E is a schematic view illustrating an embodiment of the n-node link aggregation system of FIG. 4B during the method of FIGS. 12A and 12B.

4

FIG. 13F is a schematic view illustrating an embodiment of the n-node link aggregation system of FIG. 4B during the method of FIGS. 12A and 12B.

FIG. 13G is a schematic view illustrating an embodiment of the n-node link aggregation system of FIG. 4B during the method of FIGS. 12A and 12B.

FIG. 13H is a schematic view illustrating an embodiment of the n-node link aggregation system of FIG. 4B during the method of FIGS. 12A and 12B.

DETAILED DESCRIPTION

For purposes of this disclosure, an information handling system may include any instrumentality or aggregate of instrumentalities operable to compute, calculate, determine, classify, process, transmit, receive, retrieve, originate, switch, store, display, communicate, manifest, detect, record, reproduce, handle, or utilize any form of information, intelligence, or data for business, scientific, control, or other purposes. For example, an information handling system may be a personal computer (e.g., desktop or laptop), tablet computer, mobile device (e.g., personal digital assistant (PDA) or smart phone), server (e.g., blade server or rack server), a network storage device, or any other suitable device and may vary in size, shape, performance, functionality, and price. The information handling system may include random access memory (RAM), one or more processing resources such as a central processing unit (CPU) or hardware or software control logic, ROM, and/or other types of nonvolatile memory. Additional components of the information handling system may include one or more disk drives, one or more network ports for communicating with external devices as well as various input and output (I/O) devices, such as a keyboard, a mouse, touchscreen and/or a video display. The information handling system may also include one or more buses operable to transmit communications between the various hardware components.

In one embodiment, IHS 100, FIG. 1, includes a processor 102, which is connected to a bus 104. Bus 104 serves as a connection between processor 102 and other components of IHS 100. An input device 106 is coupled to processor 102 to provide input to processor 102. Examples of input devices may include keyboards, touchscreens, pointing devices such as mice, trackballs, and trackpads, and/or a variety of other input devices known in the art. Programs and data are stored on a mass storage device 108, which is coupled to processor 102. Examples of mass storage devices may include hard discs, optical disks, magneto-optical discs, solid-state storage devices, and/or a variety other mass storage devices known in the art. IHS 100 further includes a display 110, which is coupled to processor 102 by a video controller 112. A system memory 114 is coupled to processor 102 to provide the processor with fast storage to facilitate execution of computer programs by processor 102. Examples of system memory may include random access memory (RAM) devices such as dynamic RAM (DRAM), synchronous DRAM (SDRAM), solid state memory devices, and/or a variety of other memory devices known in the art. In an embodiment, a chassis 116 houses some or all of the components of IHS 100. It should be understood that other buses and intermediate circuits can be deployed between the components described above and processor 102 to facilitate interconnection between the components and the processor 102.

Referring now to FIGS. 4A and 4B, an embodiment of a spanning tree enabled n-node link aggregation system 400 is illustrated. In many of the embodiments discussed below,

5

the spanning tree enabled n-node link aggregation system **400** utilizes Virtual Link Trunking (VLT), a proprietary link aggregation protocol available in devices provided by Dell, Inc. of Round Rock, Tex., United States, as the link aggregation protocol discussed below. However, one of skill in the art in possession of the present disclosure will recognize that other link aggregated systems using other link aggregation protocols may be enabled with the spanning tree protocol using the teachings of the present disclosure and thus will fall within its scope. In an embodiment, the spanning tree enabled n-node link aggregation system **400** includes a link aggregation fabric **402** (e.g., a VLT fabric) having a plurality of link aggregation node devices **402a**, **402b**, and **402c** that are connected together by Inter-Chassis Links (ICLs) **404** that each include one or more links between ports on the link aggregation node devices **402a-c**.

In an embodiment, each of the link aggregation node devices **402a-d** may be provided by the IHS **100** of FIG. **1** and/or may include some or all of the components of the IHS **100**. In a specific embodiment, the link aggregation node devices **402a-d** may be switches, although providing other types of computing devices as the link aggregation node devices **402a-d** may fall within the scope of the present disclosure as well. In some embodiments, the link aggregation node devices **404a-d** are VLT nodes similar to the VLT node devices **202**, **204** of FIG. **2** and the VLT node devices **302**, **304** of FIG. **3**, with the ICLs **404** similar to the ICL **206** of FIG. **2** and the ICL **306** of FIG. **3**. However, one of skill in the art in possession of the present disclosure will recognize that other link aggregated systems utilizing other types of link aggregated node devices connected by other links may be enabled with the spanning tree protocol using the teachings of the present disclosure and thus will fall within its scope.

While FIG. **4A** illustrates a particular link aggregation fabric, one of skill in the art in possession of the present disclosure will recognize that link aggregation fabrics may be provided in star configuration, ring configurations, mesh configurations, and/or a variety of other configurations known in the art. Furthermore, while only three link aggregation node devices are illustrated in FIGS. **4A** and **4B**, one of skill in the art in possession of the present disclosure will recognize that any number of link aggregation node devices (i.e., “N nodes”) may be provided in a link aggregation fabric while remaining within the scope of the present disclosure. As discussed in further detail below, the present disclosure introduces the concept of “virtual ports”, and a spanning tree protocol engine operating on any of the link aggregation node devices **402a-c** will see other link aggregation node devices as directly connected to its virtual port that connects to all of the other link aggregation node devices in the link aggregation fabric **402**. As such, FIG. **4B** illustrates the link aggregation node device including a virtual port **406a** that is connected to a virtual port **406b** on the link aggregation node device **402b** from the point of view of the spanning tree protocol engine running on that link aggregation node device **402b**, and connected to a virtual port **406c** on the link aggregation node device **402c** from the point of view of the spanning tree protocol engine running on that link aggregation node device **402b**. However, while not discussed in detail below, one of skill in the art in possession of the present disclosure will recognize that, from the point of point of view of a spanning tree protocol engine running on the link aggregation node device **402b**, the virtual port **406b** is connected to the virtual port **406a** on the link aggregation node device **402a**, and connected to the virtual port **406c** on the link aggregation node

6

device **402c**. Similarly, from the point of point of view of a spanning tree protocol engine running on the link aggregation node device **402c**, the virtual port **406c** is connected to the virtual port **406a** on the link aggregation node device **402a**, and connected to the virtual port **406b** on the link aggregation node device **402b**.

In an embodiment, the spanning tree enabled n-node link aggregation system **400** includes a networking device **408** that that is coupled to the link aggregation node devices **402b** and **402c** by a plurality of links that have been provided in a Link Aggregation Group (LAG) **410**. In an embodiment, the networking device **408** may be provided by the IHS **100** of FIG. **1** and/or may include some or all of the components of the IHS **100**. In a specific embodiment, the networking device **408** may be a switch, although providing other types of computing devices (e.g., server devices) as the networking device **408** may fall within the scope of the present disclosure as well. In some embodiments, the networking device **408** may be a TOR switch device similar to the TOR switch device of FIG. **2** and the TOR switch devices **310** and **314** of FIG. **3**, with the LAG **410** similar to the LAG **208** of FIG. **2** and the LAGs **308** and **312** of FIG. **3**. However, one of skill in the art in possession of the present disclosure will recognize that other link aggregated systems utilizing other networking devices connected to link aggregation node devices by LAGs may be enabled with the spanning tree protocol using the teachings of the present disclosure and thus will fall within its scope.

FIG. **4B** illustrates LAG port(s) **412** on the networking device **408** that are connected via the LAG **410** to LAG ports **414a** and **414b** on the link aggregation node devices **402b** and **402c**, respectively. Furthermore, FIG. **4B** illustrates non-LAG ports **416a** and **416b** (also known as “orphan ports”) on the networking device **408** which, as discussed below, may be connected to non-LAG ports **418** and **420** (also known as “orphan ports”) on the link aggregation node devices **402a** and **402b**, respectively. Finally, FIG. **4B** illustrates backup ports **422** and **424** on the link aggregation node devices **402a** and **402b**, respectively, that may be coupled together to provide a backup link. While several ports on each of the link aggregation node devices **402a-c** and the networking device **408** are illustrated and described, one of skill in the art in possession of the present disclosure will recognize that each of those devices may (and typically will) include many more ports that may be coupled to other devices while remaining within the scope of the present disclosure. Furthermore, while a simplified n-node link aggregation system is illustrated and described for clarity of discussion below, one of skill in the art will recognize that n-node link aggregation systems may (and typically will) include many more link aggregation node devices, networking devices, and other devices in other configurations while remaining within the scope of the present disclosure.

Referring now to FIG. **5**, an embodiment of a link aggregation node device **500** is illustrated that may be any of the link aggregation node devices **402a-c** discussed above with reference to FIGS. **4A** and **4B**. As such, the link aggregation node device **500** may be provided by the IHS **100** of FIG. **1** and/or may include some or all of the components of the IHS **100**, and in specific embodiments may be a VLT node such as a switch. In the illustrated embodiment, the link aggregation node device **500** includes a chassis **502** that houses the components of the link aggregation node device **500**, only some of which are illustrated in FIG. **5**. For example, the chassis **502** may house a processing system (not illustrated, but which may include the processor **102** discussed above with reference to

FIG. 1) and a memory system (not illustrated, but which may include the system memory 114 discussed above with reference to FIG. 1) that is coupled to the processing system and that includes instructions that, when executed by the processing system, cause the processing system to provide a link aggregation engine 504 and a spanning tree protocol engine 506 that are configured to perform the functions of the link aggregation engines, spanning tree protocol engines, and link aggregation node devices discussed below. In some embodiments, the link aggregation engine 504 may be a VLT engine that is configured to perform VLT operations. However, one of skill in the art in possession of the present disclosure will recognize that other link aggregation engines that perform other link aggregation protocols may fall within the scope of the present disclosure as well.

The chassis 502 may also house a storage system (not illustrated, but which may include the storage device 108 discussed above with reference to FIG. 1) that is coupled to the link aggregation engine 504 and the spanning tree protocol engine 506 (e.g., via a coupling between the storage system and the processing system) and that includes a link aggregation database 508 and a spanning tree protocol database 510 that store data for performing the functionality discussed below. The chassis 502 may also house a communication subsystem 512 that is coupled to the link aggregation engine 504 and the spanning tree protocol engine 506 (e.g., via a coupling between the communication subsystem and the processing system) and that may include a Network Interface Controller (NIC), a wireless communication device (e.g., a BLUETOOTH® communication device, a Near Field Communication (NFC) device, and/or other wireless communications devices known in the art), and/or other communication components known in the art. As such, the communication subsystem may include the ports utilized to provide the ICLs, virtual ports, LAG ports, non-LAG ports, backup ports, and/or other communication connections discussed above with reference to FIG. 4. While a specific embodiment of a link aggregation node device 500 is illustrated and described, one of skill in the art in possession of the present disclosure will recognize that other components may be included in the link aggregation node device 500 to provide conventional link aggregation node device functionality (e.g., switching functionality), as well as the functionality discussed below, while remaining within the scope of the present disclosure.

With reference to FIGS. 4A, 4B, and 5, in the embodiment of the method 600 described below, the spanning tree protocol engine 506 is provided on each of the plurality of link aggregation nodes 402a-c and includes enhancements that enable the use of the conventional spanning tree protocol in the spanning tree enabled n-node link aggregation system 400 without introducing the problems discussed above. However, this embodiment is described in an attempt to provide a clear understanding of the teachings of the present disclosure, and one of skill in the art in possession of the present disclosure will recognize that the functionality of the spanning tree protocol engine 506 may be separated into a conventional spanning tree protocol engine that performs conventional spanning tree protocol functionality, and an enhanced spanning tree protocol engine that performs the enhanced functionality described below, while remaining within the scope of the present disclosure. Furthermore, one of skill in the art in possession of the present disclosure will recognize that some or all of the functionality of the link aggregation engine 504 and the spanning tree protocol engine 506 may be provided on other devices in the spanning tree enabled n-node link aggregation system 400. For

example, the link aggregation engine 504 and/or the spanning tree protocol engine 506 may be provided on the networking 408 of FIGS. 4A and 4B while remaining within the scope of the present disclosure.

The systems of the present disclosure, discussed above, may be utilized in a variety of manners to perform methods for enabling the spanning tree protocol in an n-node link aggregation system such as, for example, an n-node VLT system. As such, different methods that illustrate and describe the functionality required to do so are discussed below. In any or all of those methods, the systems of the present disclosure may utilize the concept of the “virtual fabric port”, referred to herein generally as a “virtual port” (e.g., the virtual ports 406a, 406b, and 406c discussed above). As illustrated and described above with reference to FIG. 4A, while the link aggregation node devices 402a, 402b, and 402c may be connected by several physical ports and links, the virtual port concept allows spanning tree protocol engines running on each of the link aggregation nodes 402a-c to “see” the others of the link aggregation nodes as if they are directly connected to its virtual port (e.g., the spanning tree protocol engine running on the link aggregation node device 402a sees each of the link aggregation node device 402b and 402c as directly connected to its virtual port 406a.) As such, each of the link aggregation nodes in the spanning tree enabled n-node link aggregation system 400 includes a virtual port that connects to respective virtual ports on all of the other link aggregation node devices in the spanning tree enabled n-node link aggregation system 400.

Links to the virtual ports in the spanning tree enabled n-node link aggregation system of the present disclosure are not treated by the spanning tree protocol engines as shared links. For example, as would be understood by one of skill in the art in possession of the present disclosure, the conventional spanning tree protocol sends proposals on point-to-point links between devices, and opens up links when agreements are received, which generally provides for quick convergence of the spanning tree (e.g., under one second.) However, on shared links, the spanning tree protocol will run a timer after sending a proposal, and if no complaints or other feedback is received back within the time period monitored by the timer the port will be designated to forward data, which can take a relatively long time (e.g., twenty to thirty seconds.) As such, not treating links to virtual ports as shared links prevents such relatively long spanning tree convergence times.

In embodiments of any of the methods discussed below, the spanning tree enabled n-node link aggregation system of the present disclosure may also include a link aggregation fabric manager (e.g., a VLT fabric manager) that is provided in the link aggregation node devices 402a-c and that operates according to link aggregation protocols (e.g., VLT protocols) to prevent data loops in the link aggregation fabric (e.g., a VLT fabric), while assuring communication paths between any two link aggregation node devices. As such, the spanning tree protocol engine running on the link aggregation node devices 402a-c may operate with the assumption that there is no loop in the link aggregation fabric 402 (as such loops are prevented by the link aggregation fabric manager.) Furthermore, the spanning tree protocol engine running on the link aggregation node devices 402a-c may not operate on ICLs between link aggregation node devices, and may not calculate spanning tree protocol states for ports connected to those ICLs. As such, the ports connected to ICLs may always be in a forwarding state and not blocked. Further still, the spanning tree protocol engine

running on the link aggregation node devices **402a-c** may operate on the virtual ports provided on the link aggregation node devices, with the port path cost of those virtual ports being some minimal value (e.g., around one). As such, virtual ports may not be designated alternate/backup ports (i.e., to prevent them from being blocked, as they provide a link to the link aggregation fabric **402**.) Finally, only one non-virtual port per link aggregation domain (e.g., VLT domain) may be designated as a root port.

As is described further below, the spanning tree enabled n-node link aggregation system of the present disclosure may include some modified operations when transmitting control messages (e.g., Bridge Protocol Data Units (BPDUs)). For example, when transmitting and receiving spanning tree protocol control messages on virtual ports, the link aggregation fabric manager may create a group (e.g., a Control Plane Services (CPS) group) for link aggregation node devices in the link aggregation domain. When control messages are transmitted, the spanning tree protocol engine may then provide those control messages in an object (e.g., a CPS object) and publish that object in the group for the link aggregation node devices in the link aggregation domain. As such, each link aggregation node device may receive a single copy of the control message.

In some embodiments, a link aggregation node device in the link aggregation fabric may be designated a primary link aggregation node device (e.g., a primary VLT node) or a secondary link aggregation node device (e.g., a secondary VLT node). In such embodiments, the spanning tree protocol engine that operates on the primary link aggregation node device may control the role/state for members of a LAG (i.e., "VLT LAG members") to control, for example, whether VLT LAG members that provide the VLT LAG perform forwarding operations, blocking operations, and/or other port roles/states known in the art, and may propagate those port roles/states to the secondary link aggregation node device connected to the VLT LAG. As such, the port role/state for VLT LAG members included in a VLT LAG will remain consistent across all of the VLT LAG members on the link aggregation node devices that are connected to that VLT LAG. Furthermore, the spanning tree protocol engine operating on the link aggregation node devices may operate to ensure that each of the VLT LAGs is visible to the spanning tree protocol engine operating in the spanning tree enabled n-node link aggregation system such that each spanning tree protocol engine is aware of those VLT LAGs, which will allow a primary link aggregation node device to control the port role/state for that VLT LAG. As such, even VLT LAGs that have no links (and even no local port-channel) connected a link aggregation node device will be visible to that link aggregation node device. When control messages are received on a VLT LAG, they may be provided in an object and published to the group for the link aggregation node devices in the link aggregation domain similarly as discussed above, which allows the primary link aggregation node device to receive the control message (i.e., from the secondary link aggregation node device) even if the primary link aggregation node device does not have a VLT LAG member.

In embodiments of any of the methods discussed below, a link aggregation engine may couple a plurality of ICL ports on link aggregation node devices via ICLs. In an embodiment, a link aggregation fabric manager (e.g., a VLT fabric manager) provided in the link aggregation node devices may operate according to link aggregation protocols (e.g., the VLT protocol) to create a plurality of ICLs between link aggregation node devices in a link aggregation fabric.

For example, with reference to FIG. 4A, the link aggregation fabric manager may cause the link aggregation engines **504** provided in the link aggregation node devices **402a-c** to operate to cause the ICLs **404**, discussed above, to be created. The details of the creation of ICLs in link aggregation fabrics (e.g., the creation of ICLs in VLT fabrics according to the VLT protocol) are known in the art and will not be discussed herein in detail. The link aggregation engine **504** may also aggregate at least one LAG port on the link aggregation node devices to provide a LAG. In an embodiment, the link aggregation fabric manager (e.g., the VLT fabric manager) may operate according to link aggregation protocols (e.g., the VLT protocol) to create LAGs between at least one networking device and a plurality of link aggregation node devices. For example, with reference to FIG. 4A, the link aggregation fabric manager may cause the link aggregation engines **504** provided in the link aggregation node devices **402a-c** and/or the networking device **408** to operate to provide the LAG **410**, discussed above, to be created. The details of the creation of LAGs in link aggregation fabrics (e.g., VLT LAGs in VLT fabrics according to the VLT protocol) are known in the art and will not be discussed herein in detail.

Furthermore, while the discussion above details the creation of the ICLs and LAGs in the link aggregation fabric, other features of the link aggregation fabric (e.g., a VLT fabric) may be created prior to or during each of the methods discussed below, and other link aggregation operations may be performed, while remaining within the scope of the present disclosure. For example, the link aggregation fabric manager (e.g., a VLT fabric manager) may perform an ICL loop prevention algorithm to generate a variety of forwarding rules that are configured to break loops in the link aggregation fabric (e.g., a VLT fabric), and provide those forwarding rules to the link aggregation node devices **402a-c**. However, as discussed above, if the conventional spanning tree protocol were to then be provided on that link aggregation fabric, it would operate to block redundant ICLs, even if there is no loop in the link aggregation fabric (i.e., when a redundant ICL is part of a data loop that extends outside of the link aggregation fabric). As such, in order to provide the spanning tree protocol in the link aggregation fabric, enhancements to the spanning tree protocol are performed during the methods in order to prevent those and the other issues discussed above from occurring.

Before or during the methods below, the spanning tree protocol engines in the link aggregation node devices may be used to designate a first link aggregation node as a root bridge. In some embodiments, prior to the methods, the spanning tree protocol may be provided on each of the link aggregation node devices in the link aggregation fabric, as well as devices coupled to the link aggregation fabric. In a specific example, a single instance of the spanning tree protocol may be provided on the link aggregation node devices in the link aggregation fabric, as well as some or all of the networking devices coupled to the link aggregation fabric, according to the Institute of Electrical and Electronics Engineers (IEEE) 802.1q specification that defines a common spanning tree that provides one spanning tree instance for the entire fabric. However, in other examples, more than one instance of the spanning tree protocol may be provided on the link aggregation node devices in the link aggregation fabric. In a specific example, with reference to FIG. 4A, during or prior to the methods the spanning tree protocol may be provided on any or all of the link aggregation node devices **402a-c** and the networking device **408**. As such, the spanning tree protocol may operate to designate a device in

the spanning tree enabled n-node link aggregation system **400** as a root bridge. In an embodiment, the designation of a device as the root bridge may be in response to that device being the highest priority device in the spanning tree enabled n-node link aggregation system.

For example, as would be understood by one of skill in the art in possession of the present disclosure, a user or network administrator may configure devices in the spanning tree enabled n-node link aggregation system with “best” bridge priorities, and following the exchange of control messages (e.g., Bridging Protocol Data Units (BDPUs)) between the devices, the device with the highest priority (i.e., the “best” bridge in the topology) will be designated as the root bridge. However, the specific details of the designation of a root bridge according to the spanning tree protocol are known in the art and will not be discussed herein in detail. As such, before or during the methods, the user or network administrator will designate one of the devices in the spanning tree enabled n-node link aggregation system as the node device with the highest priority, which will cause the spanning tree protocol to designate that device as the root bridge. In the examples below, different particular devices in the spanning tree enabled n-node link aggregation system are designated as the root bridge by the spanning tree protocol, but one of skill in the art will recognize that any of the devices in the spanning tree enabled n-node link aggregation system may be designated as the root bridge (i.e., based on the prioritization of that link aggregation node device by the user/network administrator) while remaining within the scope of the present disclosure.

Thus, a variety of the functionality discussed above, as well as other functionality discussed below, may be performed to enable the use of the spanning tree protocol in an n-node link aggregation system, and one of skill in the art in possession of the present disclosure will recognize how the functionality described above may be utilized in the specific methods described below. However, while several specific methods corresponding to particular use cases are illustrated and described herein to provide examples of the functionality utilized to enable the spanning tree protocol in an n-node link aggregation system, one of skill in the art in possession of the present disclosure will also realize that other, different use cases may employ this functionality in a similar manner, and a wide variety of modification to the methods and functionality discussed below is envisioned as falling within the scope of the present disclosure.

Referring now to FIG. 6, a specific embodiment of a method **600** for enabling the spanning tree protocol in an n-node link aggregation system is illustrated. The system and method **600** are described below to provide an example of the use of the teachings of the present disclosure to provide a spanning tree protocol topology convergence when a link aggregation node device is provided as a root bridge. As such, when the VLT protocol is used as the link aggregation protocol, the method **600** provides for spanning tree protocol convergence when a VLT node is provided as the root bridge (discussed above.) In this example, the link aggregation node device **402a** is designated as the primary link aggregation node device, while the link aggregation node devices **402b** and **402c** are designated as secondary link aggregation node devices. However, other nodes in the network (e.g., non-VLT nodes) may be designated as a root bridge as well.

Referring now to FIG. 7A, the method **600** begins at block **602** where a first link aggregation node device is designated as a root bridge and causes second and third virtual ports on second and third link aggregation node devices to be

designed as root ports. In an embodiment, at block **602**, the spanning tree protocol engine **506** running on the device(s) in the spanning tree enabled n-node link aggregation system **400** may designate the link aggregation node device **402c** as a root bridge (e.g., because the link aggregation node device **402c** is the highest priority device in the spanning tree enabled n-node link aggregation system **400** as discussed above). In response to the link aggregation node device **402c** being designated as the root bridge, the spanning tree protocol engine **506** running on the device(s) in the spanning tree enabled n-node link aggregation system **400** will operate to designate the virtual port **406c** in the link aggregation node device **402c** as a designated port (indicated by the “D” in the virtual port **406c** illustrated in FIG. 7A), while designating the virtual port **406a** in the link aggregation node device **402a** and the virtual port **406b** in the link aggregation node device **402b** as root ports (indicated by the “R” in the virtual ports **406a** and **406b** illustrated in FIG. 7A). For example, the link aggregation node device **402a** operating as the primary link aggregation node device and the root bridge may send control messages (e.g., BPDUs) over the links between the virtual ports **406a** and each of the virtual ports **406b** and **406c** to cause the designation of the designated ports and the root ports as discussed above (e.g., each of the virtual ports **406a**, **406b**, and **406c** will send BPDUs until the designated port and root port designations are made, after which virtual ports **406b** and **406c** (designated as root ports) will stop sending BPDUs and virtual port **406c** (designated as a designated port) will continue sending BPDUs.)

Referring now to FIG. 7B, the method **600** then proceeds to block **604** where a networking device connected to the first and second link aggregation node devices via a LAG causes LAG ports on the first and second link aggregation node devices to be designated as designated ports, and a LAG port on the networking device to be designated as a root port. For the purposes of this example, the networking device **408** is a lower priority device than the link aggregation node device **402c** (which is the highest priority device in the system, hence its designation as the root bridge.) In an embodiment, at block **604**, the link aggregation engine **504** may operate to provide the LAG **410** between the networking device **408** and the link aggregation node devices **402b** and **402c** as discussed above. For purposes of the discussions below, the LAG **410** may have a path cost of fifty. In response to the LAG **410** being provided between the networking device **408** and the link aggregation node devices **402b** and **402c**, the spanning tree protocol engine **506** running on the device(s) in the spanning tree enabled n-node link aggregation system **400** will operate to designate the LAG port **412** on the networking device **408** as a root port (indicated by the “R” in the LAG port **412** illustrated in FIG. 7B), while designating the LAG port **414a** in the link aggregation node device **402b** and the LAG port **414b** in the link aggregation node device **402c** as designated ports (indicated by the “D” in the LAG ports **414a** and **414b** illustrated in FIG. 7B.)

Referring now to FIG. 7C, the method **600** then proceeds to block **606** where a non-LAG link between the networking device and the first link aggregation node device causes a non-LAG port on the first link aggregation node device to be designated as a designated port and a non-LAG port on the networking device to be designated as an alternate port. In an embodiment, at block **606**, a non-LAG link **700** may be provided between the non-LAG port **416b** on the networking device **408** and the non-LAG port **420** on the link aggregation node device **402c**, as illustrated in FIG. 7C. For the

purposes of this example, the non-LAG link **700** may have a path cost of one hundred, which is greater than the path cost of the LAG **410**, discussed above. In response to the non-LAG link **700** being provided between the non-LAG port **416b** on the networking device **408** and the non-LAG port **420** on the link aggregation node device **402c**, the spanning tree protocol engine **506** running on the device(s) in the spanning tree enabled n-node link aggregation system **400** will operate to designate the non-LAG port **416b** on the networking device **408** as an alternate port (indicated by the “A” in the non-LAG port **416b** illustrated in FIG. 7C), while designating the non-LAG port **420** in the link aggregation node device **402c** as a designated port (indicated by the “D” in the non-LAG port **420** illustrated in FIG. 7C.) For example, state event machines operating in the link aggregation node device **402c** and the networking device **408** may cause the designation of the designated ports and alternate ports discussed above. FIG. 7C illustrates how designation of the non-LAG port **416b** in the networking device **408** as an alternate port causes the non-LAG port **416b** to be blocked as indicated by the “no”/circle/backslash symbol. Thus, the system and methods of the present disclosure provide a spanning tree protocol topology convergence when a link aggregation node device is provided as a root bridge, while ensuring that loops will be blocked (e.g., via the blocking of the non-LAG port **416b** on the networking device **408** via its designation as an alternate port.)

Referring now to FIG. 8, a specific embodiment of a method **800** for enabling the spanning tree protocol in an n-node link aggregation system is illustrated. The system and method **800** are described below to provide an example of the use of the teachings of the present disclosure to provide a spanning tree protocol topology convergence without loops when a networking device outside of the link aggregation fabric is provided as a root bridge and connected to the link aggregation node devices via a LAG and a non-LAG link. In this example, the link aggregation node device **402a** is designated as the primary link aggregation node device, while the link aggregation node devices **402b** and **402c** are designated as secondary link aggregation node devices.

Referring now to FIG. 9A, the method **800** begins at block **802** where a first link aggregation node device is designated as a root bridge and causes second and third virtual ports on second and third link aggregation node devices to be designed as root ports. In an embodiment, at block **802**, the spanning tree protocol engine **506** running on the device(s) in the spanning tree enabled n-node link aggregation system **400** may designate the link aggregation node device **402a** as a root bridge (e.g., because the link aggregation node device **402a** is the highest priority link aggregation node device in the link aggregation fabric **400**, as discussed above). In response to the link aggregation node device **402a** being designated as the root bridge, the spanning tree protocol engine **506** running on the device(s) in the spanning tree enabled n-node link aggregation system **400** will operate to designate the virtual port **406a** in the link aggregation node device **402a** as a designated port (indicated by the “D” in the virtual port **406c** illustrated in FIG. 7A), while designating the virtual port **406b** in the link aggregation node device **402b** and the virtual port **406c** in the link aggregation node device **402c** as root ports (indicated by the “R” in the virtual ports **406a** and **406b** illustrated in FIG. 9A). For example, each of the virtual ports in the link aggregation node devices will exchange BPDUs with information that causes the designation of the designated ports and root ports as discussed above.

Referring now to FIG. 9B, the method **800** then proceeds to block **804** where a networking device connected to the second and third link aggregation node devices via a LAG is designated as the root bridge based on its higher priority than the first link aggregation node device. For the purposes of this example, the networking device **408** is a higher priority device than the link aggregation node device **402a**, and thus at block **804** the spanning tree protocol engine **506** running on the device(s) in the spanning tree enabled n-node link aggregation system **400** may designate the networking device **408** as the root bridge (e.g., because the networking device is the highest priority device in the spanning tree enabled n-node link aggregation system **400**, as discussed above). In an embodiment, at block **804**, the link aggregation engine **504** may operate to provide the LAG **410** between the networking device **408** and the link aggregation node devices **402b** and **402c** as discussed above. For purposes of the discussions below, the LAG **410** may have a path cost of fifty. In response to the LAG **410** being provided between the networking device **408** and the link aggregation node devices **402b** and **402c**, the spanning tree protocol engine **506** running on the device(s) in the spanning tree enabled n-node link aggregation system **400** will operate to designate the LAG port **412** on the networking device **408** as a designated port (indicated by the “D” in the LAG port **412** illustrated in FIG. 9B), while designating the LAG port **414a** in the link aggregation node device **402b** and the LAG port **414b** in the link aggregation node device **402c** as root ports (indicated by the “R” in the LAG ports **414a** and **414b** illustrated in FIG. 9B.) For example, the networking device **408** operating as the root bridge may send control messages (e.g., BPDUs) over the LAG **410** and the links between the virtual ports to the link aggregation node device **402a** acting as the primary link aggregation node device, and the link aggregation node device **402a** acting as the primary link aggregation node device may use those control messages (e.g., compare the information in those BPDUs to information received in BPDUs from other link aggregation node devices), as well as generate control messages and send them over the links between the virtual ports to cause the designation of the designated ports and root ports as discussed above.

Referring now to FIGS. 9C and 9D, the method **800** then proceeds to block **806** where a non-LAG link between the networking device and a non-LAG port on the second link aggregation node device causes the second virtual port on the second link aggregation node device to be redesignated as an alternate port, and a non-LAG port on the second link aggregation node device to be designated as a root port. In an embodiment, at block **806**, a non-LAG link **800** may be provided between the non-LAG port **416b** on the networking device **408** and the non-LAG port **420** on the link aggregation node device **402**, as illustrated in FIG. 9C. For the purposes of this example, the non-LAG link **800** may have a path cost of fifty, which is equal to the port path cost of the LAG **410**, discussed above. In response to the non-LAG link **800** being provided between the non-LAG port **416b** on the networking device **408** and the non-LAG port **420** on the link aggregation node device **402**, the spanning tree protocol engine **506** running on the device(s) in the spanning tree enabled n-node link aggregation system **400** will operate to designate the non-LAG port **416b** on the networking device **408** as a designated port (indicated by the “D” in the non-LAG port **416b** illustrated in FIG. 9C). For example, a state event machine operating in the networking device **408** may cause the designation of the designated ports discussed above.

Furthermore, in response to the non-LAG link **700** being provided between the non-LAG port **416b** on the networking device **408** and the non-LAG port **420** on the link aggregation node device **402**, the spanning tree protocol engine **506** running on the device(s) in the spanning tree enabled n-node link aggregation system **400** will operate to redesignate the virtual port **406c** in the link aggregation node device **402c** from a root port (indicated by the “R” in the virtual port **406c** illustrated in FIG. 9C) to an alternate port (indicated by the “A” in the virtual port **406c** illustrated in FIG. 9D), while also designating the non-LAG port **420** in the link aggregation node device **402c** as a root port (indicated by the “R” in the non-LAG port **420** illustrated in FIG. 9D) One of skill in the art in possession of the present disclosure will recognize that such conventional operation of the spanning tree protocol would block the virtual port **406c** (i.e., as indicated by the “no”/circle/backslash symbol due to its designation as an alternate port) that provides a link to the link aggregation node device **402a** in the link aggregation fabric (and hence connectivity to the link aggregation fabric and each of the link aggregation nodes), and that block **808** of the method is performed to prevent such blocking from happening.

The method **800** then proceeds to block **808** where the second virtual port on the second link aggregation node device is redesignated as a root port and the non-LAG port on the second link aggregation node device is redesignated as an alternate port. In an embodiment, at block **808**, the spanning tree protocol engine **506** running on the device(s) in the spanning tree enabled n-node link aggregation system **400** will operate to redesignate the virtual port **406c** in the link aggregation node device **402c** from an alternate port (indicated by the “A” in the virtual port **406c** illustrated in FIG. 9D) to a root port (indicated by the “R” in the virtual port **406c** illustrated in FIG. 9E), while also redesignating the non-LAG port **420** in the link aggregation node device **402c** from a root port (indicated by the “R” in the non-LAG port **420** illustrated in FIG. 9D) to an alternate port (indicated by the “A” in the non-LAG port **420** illustrated in FIG. 9E.) FIG. 9E illustrates how designation of the non-LAG port **420** in the link aggregation node device **402c** as an alternate port causes the non-LAG port **420** to be blocked as indicated by the “no”/circle/backslash symbol. Thus, the system and methods of the present disclosure provide a spanning tree protocol topology convergence when a networking device that is outside of the link aggregation fabric is provided as a root bridge and coupled to the link aggregation fabric via a LAG and a non-LAG link, while ensuring that links between the link aggregation node devices are not blocked (e.g., via the redesignation of the virtual port **406c** on the link aggregation node device **402c** from an alternate port to a root port), and ensuring that loops will be blocked (e.g., via the blocking of the non-LAG port **420** on the link aggregation node device **402c** due to its redesignation from a root port to an alternate port.)

Referring now to FIG. 10, a specific embodiment of a method **1000** for enabling the spanning tree protocol in an n-node link aggregation system is illustrated. The system and method **1000** are described below to provide an example of the use of the teachings of the present disclosure to address link failure between primary and secondary link aggregation node devices in a link aggregation fabric following a spanning tree protocol topology convergence without loops when a networking device outside of the link aggregation fabric is provided as a root bridge and connected to the link aggregation node devices via a LAG and a non-LAG link. This example continues with the spanning

tree enabled n-node link aggregation system **400** provided in the state described above following block **808** of the method **800** and, as such, the virtual ports, LAG ports, and non-LAG ports illustrated in FIG. 11A include the same designations as those illustrated in FIG. 9E. In addition, a backup link **1000** is provided between the backup ports **422** and **424** on the link aggregation node devices **402a** and **402b**, and one of skill in the art in possession of the present disclosure will recognize that the backup link **1000** may be provided in the other methods described herein while remaining within the scope of the present disclosure as well. While the backup link **1000** is discussed below as being provided for use in detecting whether a primary link aggregation node is operating, other uses for the backup link **1000** will fall within the scope of the present disclosure as well.

The method **1000** begins at block **1002** where a virtual links between a first link aggregation node device and second and third link aggregation node devices become unavailable. In an embodiment, at block **1002**, the virtual links between the virtual port **406a** on the link aggregation node device **402a** (which is acting as the primary link aggregation node device) and each respective virtual port **406b** on the link aggregation node device **402b** and virtual port **406c** on the link aggregation node device **402c** become unavailable. For example, with reference to FIG. 4A, the ICLs **404** between the link aggregation node device **402a** and each of the link aggregation node devices **402b** and **402c** may “go down”, become disconnected, or otherwise become unavailable for communications between the link aggregation node device **402a** and each of the link aggregation node devices **402b** and **402c**. FIG. 11A illustrates the spanning tree enabled n-node link aggregation system **400** with each of the virtual links between the virtual port **406a** on the link aggregation node device **402a** and each respective virtual port **406b** on the link aggregation node device **402b** and the virtual port **406c** on the link aggregation node device **402c** unavailable via a “no”/circle/backslash symbol. For example, a virtual port on a link aggregation node device may be made unavailable when each of the ICLs/VLTi’s available to that link aggregation node device are unavailable, while that virtual port may be made available if at least one ICL/VLTi is available.

The method **1000** then proceeds to block **1004** where a second virtual port on the second link aggregation node device is redesignated as a designated port and a non-LAG port on the second link aggregation node device is redesignated as a root port. In an embodiment, at block **1004**, the spanning tree protocol engine **506** running on the device(s) in the spanning tree enabled n-node link aggregation system **400** will operate to redesignate the virtual port **406c** in the link aggregation node device **402c** from a root port port (indicated by the “R” in the virtual port **406c** illustrated in FIG. 11A) to a designated port (indicated by the “D” in the virtual port **406c** illustrated in FIG. 11B), while also redesignating the non-LAG port **420** in the link aggregation node device **402c** from an alternate port (indicated by the “A” in the non-LAG port **420** illustrated in FIG. 11A) to a root port (indicated by the “R” in the non-LAG port **420** illustrated in FIG. 11B.) For example, state event machines operating in the link aggregation node device **402c** and the networking device **408** may cause the re designation of the designated ports, root ports, and alternate ports discussed above. One of skill in the art in possession of the present disclosure will recognize that such conventional operation of the spanning tree protocol would create a loop (i.e., due to the redesignation of the non-LAG port **420** on the link aggregation node

device **402c** from an alternate port to a root port), and that block **1006** of the method is performed to prevent such loops from occurring.

The method **1000** then proceeds to block **1006** where the LAG between the networking device and the second and third link aggregation node devices is blocked. In an embodiment, the link aggregation node device **402b** (operating as the secondary link aggregation node device in this example), may determine that the link aggregation node device **402a** (operating as the primary link aggregation node device in this example) is “alive” (i.e., operating) via the backup link **1000** even through the link aggregation node device **402a** is unavailable via its virtual port link. In such a situation, the VLT LAG port role/state is in control of the link aggregation node device **402a** (i.e., because it is the primary link aggregation node device), but the link aggregation node device **402a** is unable to control that VLT LAG port role state (i.e., because the ICLs/VLTi to the secondary link aggregation node device are down or otherwise unavailable, preventing the exchange of BPDUs that would allow the changing of the VLT LAG port role state(s)). As such, in conventional systems the LAG ports **414a** and **414b** would remain in a root role/state, while the link aggregation node device **402c** would open up non-LAG port **420** (i.e., because it is receiving the best root information) and create a loop.

The method **1000** avoids loops by, at block **1006**, having the secondary link aggregation node device **402b** in the spanning tree enabled n-node link aggregation system **400** operate to block each of the LAG links that provide the LAG **410** between the LAG port(s) **412** on the networking device **408** and the LAG ports **414a** and **414b** on each of the link aggregation node devices **402b** and **402c**, respectively. For example, in response to determining that the primary link aggregation node device is not accessible via its virtual port (but is accessible via the backup link **1000**), at block **1006** the link aggregation node device **402b** operating as a secondary link aggregation node device may cause the LAG links that provide the LAG **410** between the LAG port(s) **412** on the networking device **408** and the LAG ports **414a** and **414b** on each of the link aggregation node devices **402b** and **402c** to shut down (e.g., put in an “operationally down” state in which no data and/or control packets may be transmitted via those LAG ports.) Thus, the system and methods of the present disclosure addresses link failure between primary and secondary link aggregation node devices in a link aggregation fabric following a spanning tree protocol topology convergence without loops when a networking device outside of the link aggregation fabric is provided as a root bridge and connected to the link aggregation node devices via a LAG and a non-LAG link (e.g., via the blocking of a LAG between the networking device **408** and the link aggregation node devices **402b** and **402c** following the redesignation of the non-LAG port **420** on the link aggregation node device **402c** from an alternate port to a root port, which would otherwise cause a loop in the spanning tree enabled n-node link aggregation system **400**.)

Referring now to FIGS. **12A** and **12B**, a specific embodiment of a method **1200** for enabling the spanning tree protocol in an n-node link aggregation system is illustrated. The system and method **1200** are described below to provide an example of the use of the teachings of the present disclosure to provide a spanning tree protocol topology convergence without loops when a networking device outside of the link aggregation fabric is provided as a root bridge and connected to the link aggregation node devices via multiple non-LAG links. In addition, the system and method **1200** also provide an example of a proposal and

agreement mechanism via the virtual ports of the present disclosure. In conventional spanning tree protocol proposal and agreement mechanisms, prior to designating a new root port, the spanning tree protocol ensures that that root port will not cause a loop. One of skill in the art in possession of the present disclosure will recognize that this may be accomplished by blocking all designated ports and sending a proposal over those designated ports when new root information is received (e.g., by setting a sync flag to “true”), and then unblocking those designated ports when an agreement is received from the new (peer) root port. However, as discussed below, the proposal and agreement mechanism via the virtual ports of the present disclosure does not operate to put a virtual port on a link aggregation node device that has been designated as designated port into a forwarding state when a non-virtual port on that link aggregation node device is designated as a root port, as doing so creates a loop. Instead, the virtual port on that link aggregation node device will only be put into a forwarding state after receiving agreements from all the peer link aggregation nodes, as discussed in detail below. In some embodiments, ICLs may be temporarily blocked (e.g., on the order of milliseconds) during the proposal and agreement mechanism.)

Referring to FIG. **13A**, prior to or during the method **1200**, the networking device **408** is connected to the link aggregation node device **402c** via a non-LAG link **1300** between the non-LAG port **416b** on the networking device **408** and the non-LAG link **420** on the link aggregation node device **402c**. For the purposes of this discussion, the non-LAG link **1300** has a path cost of fifty. Furthermore, it is noted that, in this embodiment, the networking device **408** is not connected to the link aggregation fabric **402** by a LAG (i.e., the LAG **410** discussed above), and is a higher priority device than any of the link aggregation node devices in the link aggregation fabric **402**. As such, the spanning tree protocol engine **506** running on the device(s) in the spanning tree enabled n-node link aggregation system **400** may designate the networking device **408** as the root bridge (e.g., because the networking device is the highest priority device in the spanning tree enabled n-node link aggregation system **400**, as discussed above).

In addition, the spanning tree protocol engine **506** running on the device(s) in the spanning tree enabled n-node link aggregation system **400** will operate to designate the non-LAG port **416b** on the networking device **408** as a designated port (indicated by the “D” in the non-LAG port **416b** illustrated in FIG. **9B**), while designating the non-LAG port **420** in the link aggregation node device **402c** as a root port (indicated by the “R” in the non-LAG port **420** illustrated in FIG. **13A**), designating the virtual port **406c** in the link aggregation node device **402c** as a designated port (indicated by the “D” in the virtual port **406c** illustrated in FIG. **13A**), and designating the virtual ports **406a** and **406b** in the link aggregation node devices **402a** and **402b**, respectively, as root ports (indicated by the “R” in the virtual ports **406a** and **406b** illustrated in FIG. **13A**.)

Referring now to FIG. **13B**, the method **1200** begins at block **1202** where a non-LAG link between a networking device and a third link aggregation node device causes a non-LAG port on the networking device to be designated as an alternate port. In an embodiment, at block **1202**, a non-LAG link **1302** is provided between the non-LAG port **416a** on the networking device **408** and the non-LAG port **418** on the link aggregation node device **402a**. For the purposes of this discussion, the non-LAG link **1302** has a path cost of ten, which is a lower path cost than the

19

non-LAG link **1300**. In response to the non-LAG link **1302** being provided between the non-LAG port **416a** on the networking device **408** and the non-LAG port **418** on the link aggregation node device **402a**, the spanning tree protocol engine **506** running on the device(s) in the spanning tree enabled n-node link aggregation system **400** will operate to designate the non-LAG port **416a** on the networking device **408** as a designated port (indicated by the “D” in the non-LAG port **416a** illustrated in FIG. 13B.)

Referring now to FIG. 13C, the method **1200** then proceeds to block **1204** where the networking device blocks forwarding on the non-LAG port and sends a proposal through the non-LAG port to a third link aggregation node device. In an embodiment, at block **1204**, the networking device **408** will operate to block the non-LAG port **416a** (as indicated by the “no”/circle/backslash symbol), and send a control message **1304** that includes a proposal over the non-LAG link **1302** to the link aggregation node device **402a**.

Referring now to FIG. 13D, the method **1200** then proceeds to block **1206** where the proposal is received by the third link aggregation node device and causes a non-LAG port on the third link aggregation node device to be designated as a root port and a third virtual port on the third link aggregation node device to be designated as a designated port. In an embodiment, at block **1206**, the link aggregation node device **402a** receives the control message **1304** and, in response, designates the non-LAG port **418** on the link aggregation node device **402a** a root port (indicated by the “R” in the non-LAG port **418** illustrated in FIG. 13D), and redesignates the virtual port **406a** in the link aggregation node device **402a** from a root port (indicated by the “R” in the virtual port **406a** illustrated in FIG. 13C) to a designated port (indicated by the “D” in the virtual port **406a** illustrated in FIG. 13D.) In addition, the virtual port **406a** on the link aggregation node device **402a** that has been designated as designated port is blocked (e.g., by setting a sync flag to “true”) when the non-LAG port **418** on the link aggregation node device **402a** is designated as a root port, as allowing that virtual port **406a** to forward data would create a loop.

The method **1200** then proceeds to block **1208** where the third link aggregation node device sends a control message with the proposal through a third virtual port on the third link aggregation node device to the first and second link aggregation node devices. In an embodiment, at block **1208**, the link aggregation node device **402a** sends a control message **1304** including the proposal over the link between the virtual port **406a** on the link aggregation node device **402a** and each of the virtual port **406b** on the link aggregation node device **402b** and the virtual port **406c** on the link aggregation node device **402c**.

Referring now to FIG. 13E, the method **1200** then proceeds to block **1210** where the second link aggregation node device blocks its designated ports and sends an agreement to the third link aggregation node device. In an embodiment, at block **1210**, the link aggregation node device **402b** receives the control message **1304** including the proposal through its virtual port **406b** and, in response, blocks any designated ports on the link aggregation node device **402b** (not illustrated), and sends a control message **1308** including an agreement over the link between the virtual port **406b** on the link aggregation node device **402b** and the virtual port **406a** on the link aggregation node device **402a**.

Referring now to FIG. 13F, the method **1200** then proceeds to block **1212** where the first link aggregation node device redesignates its virtual port as a root port and its non-LAG port as an alternate port, and sends an agreement

20

to the third link aggregation node device. In an embodiment, at block **1212**, the link aggregation node device **402c** receives the control message **1304** including the proposal through its virtual port **406c** and, in response, redesignates the virtual port **406c** on the link aggregation node device **402c** from a designated port (indicated by the “D” in the virtual port **406c** illustrated in FIG. 13E) to a root port (indicated by the “R” in the virtual port **406c** illustrated in FIG. 13F), and redesignates the non-LAG port **420** in the link aggregation node device **402c** from a root port (indicated by the “R” in the non-LAG port **420** illustrated in FIG. 13E) to an alternate port (indicated by the “A” in the non-LAG port **420** illustrated in FIG. 13F.) FIG. 13F illustrates how redesignation of the non-LAG port **420** in the link aggregation node device **402c** to an alternate port causes the non-LAG port **420** to be blocked as indicated by the “no”/circle/backslash symbol. Furthermore, at block **1212**, the link aggregation node device **402c** then sends a control message **1310** including an agreement over the link between the virtual port **406c** on the link aggregation node device **402c** and the virtual port **406a** on the link aggregation node device **402a**.

Referring now to FIG. 13G, the method **1200** then proceeds to block **1214** where the third link aggregation node device receives agreements from the first and second link aggregation nodes devices and sends an agreement to the networking device. In an embodiment, at block **1214**, the link aggregation node device **402a** receives the control messages **1308** and **1310** from the link aggregation node devices **402b** and **402c** (i.e., via its virtual port **406a**) and, in response, send a control message **1312** including an agreement over the non-LAG link **1302** between the non-LAG port **418** on the link aggregation node device **402a** and the non-LAG port **416a** on the networking device **408**. Furthermore, as illustrated in FIG. 13G, in response to receiving the agreement from each of the link aggregation node devices **402b** and **402c**, the link aggregation node device **402a** unblocks its virtual port **406a** and puts it in a forwarding state.

Referring now to FIG. 13H, the method **1200** then proceeds to block **1216** where the networking device unblocks the non-LAG port on the networking device. In an embodiment, at block **1216**, the networking device receives the control message **1312** from the link aggregation node device **402a** and, in response, unblocks the non-LAG port **416a** on the networking device **408** that was designated as a designated port. Thus, the system and methods of the present disclosure provide a spanning tree protocol topology convergence without loops when a networking device outside of the link aggregation fabric is provided as a root bridge and connected to the link aggregation node devices via multiple non-LAG link by not putting a virtual port on a link aggregation node device that has been designated as designated port into a forwarding state when a non-virtual port on that link aggregation node device is designated as a root port, and instead only putting that virtual port on that link aggregation node device into a forwarding state after receiving agreements from all the peer link aggregation nodes. Furthermore, one of skill in the art in possession of the present disclosure will recognize how this proposal agreement mechanism may operate when new link aggregation node devices are added to the link aggregation fabric.

In many embodiments of the present disclosure, the spanning tree protocol engines running on the devices in the spanning tree enabled n-node link aggregation system **400** will be aware of each of the link aggregation node devices in the link aggregation fabric, as the link aggregation fabric

manager will publish/update the system topology whenever there is a change. As such, if any of the link aggregation node devices become unavailable while a link aggregation node device (e.g., the link aggregation node device **402a** in the example above) is waiting for an agreement to a proposal, an agreement from that unavailable link aggregation node may not be received, and the spanning tree protocol engines running on the spanning tree enabled n-node link aggregation system **400** will be waiting for that agreement (i.e., in order to unblock the non-LAG port **416** on the networking device **408** in the example above.) In such situations, the spanning tree protocol engines running on the spanning tree enabled n-node link aggregation system **400** will cease waiting for agreement from the failed node once the link aggregation fabric manager publishes/updates the system topology. In some embodiments, the spanning tree protocol engines running on the spanning tree enabled n-node link aggregation system **400** may set a timer after sending a proposal, and if agreements are not received by the expiration of that timer, the virtual port may be set to a forwarding state.

Thus, the system and methods of the present disclosure provide for the enablement of the spanning tree protocol on any n-node link aggregation fabric by allowing the spanning tree protocol to visualize that n-node link aggregation fabric topology as n-nodes connected to a single network without a loop (i.e., via the virtual ports discussed above.) As such, the spanning tree protocol only operates to block non-ICL links for loop prevention. The systems and methods provide spanning tree enabled link aggregation fabrics that are easier to design and implement, and can be used to realize distributed spanning tree protocol operation in a chassis or stacking environment.

One of skill in the art will recognize how the teachings of the present disclosure will enable responses to a variety of failure scenarios. For example, in the spanning tree enabled n-node link aggregation system **400** of FIG. **9A** with the link aggregation node device **402b** acting as a secondary link aggregation node device that has a priority necessary to become a root bridge, the failure of the link aggregation node device **402a** acting as a primary link aggregation node device and operating as the root bridge will result in that link aggregation node device **402b** being designated as the primary link aggregation node device and the root bridge, along with the redesignation of the virtual port **406b** on the link aggregation node device **402b** from a root port to a designated port. Similarly, in the spanning tree enabled n-node link aggregation system **400** of FIG. **9A** with the networking device **408** having a priority necessary to become a root bridge, the failure of a link aggregation node device **402a** operating as the root bridge will result in the link aggregation node device **402b** being designated as the primary link aggregation node device, the networking device **408** being designated as the root bridge, along with the redesignation of the LAG port **412** on the networking device **408** from a root port to a designated port, the redesignation of LAG ports **414a** and **414b** on the link aggregation node devices **402b** and **402c** from designated ports to root ports, and the redesignation of the virtual port **406b** on link aggregation node device **402b** from a root port to a designated port. While a few failure scenarios have been described, a wide variety of failure scenarios may be addressed by the teachings of the present disclosure.

Although illustrative embodiments have been shown and described, a wide range of modification, change and substitution is contemplated in the foregoing disclosure and in some instances, some features of the embodiments may be

employed without a corresponding use of other features. Accordingly, it is appropriate that the appended claims be construed broadly and in a manner consistent with the scope of the embodiments disclosed herein.

What is claimed is:

1. A spanning tree enabled n-node link aggregation system, comprising:

- a plurality of link aggregation node devices that include:
 - a first link aggregation node device that includes a first virtual port and that has the highest priority of the plurality of link aggregation node devices; and
 - a second link aggregation node device that includes a Link Aggregation Group (LAG) port, a non-LAG port, and a second virtual port that is coupled to the first virtual port included on the first link aggregation node device; and

- a spanning tree protocol engine running on the each of the plurality of link aggregation node devices, wherein the spanning tree protocol engine is configured to:

- designate the first link aggregation node device as a root bridge based on the first link aggregation node device having the highest priority of the plurality of link aggregation node devices and, in response, designate the first virtual port as a designated port and the second virtual port as a root port;

- determine that a networking device that is coupled to the LAG port on the second link aggregation node device has a higher priority than the first link aggregation node device and, in response, designate the networking device as the root bridge; and
- determine that a non-LAG link provided between the networking device and the second link aggregation node device has caused the second virtual port to be redesignated as an alternate port and the non-LAG port to be designated as a root port and, in response, redesignate the second virtual port as a root port and redesignate the non-LAG port as an alternate port.

2. The system of claim 1, wherein the spanning tree protocol engine is configured to:

- designate the LAG port on the second link aggregation node device as a root port in response to designating the networking device as the root bridge.

3. The system of claim 1, wherein the spanning tree protocol engine is configured to:

- determine that a virtual port link between the first virtual port and the second virtual port has become unavailable and caused the second virtual port to be redesignated as a designated port and the non-LAG port to be redesignated as a root port and, in response, block the LAG port.

4. The system of claim 3, wherein the first link aggregation node device is configured to control the second link aggregation node device while the virtual port link is unavailable via a backup link to a third link aggregation node device that is included in the plurality of link aggregation node devices and that is connected to the second link aggregation node device.

5. The system of claim 1, wherein the spanning tree protocol engine is configured to:

- create a control plane group for the plurality of link aggregation node devices; and

- publish a control message to the control plane group such that each of the plurality of link aggregation node devices receives a copy of the control message.

23

6. The system of claim 1, wherein the first link aggregation node device is a primary link aggregation node device, the second link aggregation node device is a secondary link aggregation node device, and the first link aggregation node device is the only link aggregation node device of the plurality of link aggregation node devices that is configured to control the designation of the LAG port on the second link aggregation node device.

7. The system of claim 1, wherein the determining that the non-LAG link provided between the networking device and the second link aggregation node device has caused the second virtual port to be redesignated as an alternate port and the non-LAG port to be designated as a root port includes:

determining that a State Event Machine (SEM) is attempting to assign an alternate role for the second virtual port and a root role for the non-LAG port.

8. An Information Handling System (IHS), comprising: a communication subsystem that provides a Link Aggregation Group (LAG) port, a non-LAG port, and a first virtual port;

a processing system that is coupled to the communication subsystem, and

a memory system that is coupled to the processing system and that includes instructions that, when executed by the processing system, cause the processing system to provide a spanning tree protocol engine that is configured to:

determine that a link aggregation node device including a second virtual port coupled to the first virtual port has been designated as a root bridge and, in response, designate the first virtual port as a root port;

determine that a networking device that is coupled to the LAG port has a higher priority than the link aggregation node device and has been designated as the root bridge; and

determine that a non-LAG link provided between the networking device and the non-LAG port has caused the first virtual port to be redesignated as an alternate port and the non-LAG port to be designated as a root port and, in response, redesignate the first virtual port as a root port and redesignate the non-LAG port as an alternate port.

9. The IHS of claim 8, wherein the spanning tree protocol engine is configured to:

designate the LAG port as a root port in response to the networking device being designated as the root bridge.

10. The IHS of claim 8, wherein the spanning tree protocol engine is configured to:

determine that a virtual port link between the first virtual port and the second virtual port has become unavailable and caused the first virtual port to be redesignated as a designated port and the non-LAG port to be redesignated as a root port and, in response, block the LAG port.

11. The IHS of claim 10, wherein the spanning tree protocol engine is configured to:

create a control plane group for a plurality of link aggregation node devices that includes the link aggregation node device; and

publish a control message to the control plane group such that each of the plurality of link aggregation node devices receives a copy of the control message.

12. The IHS of claim 8, wherein the link aggregation node device is a primary link aggregation node device and the only link aggregation node device of a plurality of link

24

aggregation node devices that is configured to control the designation of the LAG port on the communication subsystem.

13. The IHS of claim 8, wherein the determining that the non-LAG link provided between the networking device and the non-LAG port has caused the first virtual port to be redesignated as an alternate port and the non-LAG port to be designated as a root port includes:

determining that a State Event Machine (SEM) is attempting to assign an alternate role for the first virtual port and a root role for the non-LAG port.

14. A method for enabling spanning tree protocol in an n-node link aggregation system, comprising:

designating, by a spanning tree protocol engine, a first link aggregation node device as a root bridge based on the first link aggregation node device having the highest priority of a plurality of link aggregation node devices and, in response, designating a first virtual port on the first link aggregation node device as a designated port, and designating a second virtual port on a second link aggregation node device that is coupled to the first virtual port as a root port;

determining, by the spanning tree protocol engine, that a networking device that is coupled to a LAG port on the second link aggregation node device has a higher priority than the first link aggregation node device and, in response, designating the networking device as the root bridge; and

determining, by the spanning tree protocol engine, that a non-LAG link provided between the networking device and a non-LAG port on the second link aggregation node device has caused the second virtual port to be redesignated as an alternate port and the non-LAG port to be designated as a root port and, in response, redesignating the second virtual port as a root port and redesignating the non-LAG port as an alternate port.

15. The method of claim 14, further comprising:

designating, by the spanning tree protocol engine, the LAG port on the second link aggregation node device as a root port in response to designating the networking device as the root bridge.

16. The method of claim 14, further comprising:

determining, by the spanning tree protocol engine, that a virtual port link between the first virtual port and the second virtual port has become unavailable and caused the second virtual port to be redesignated as a designated port and the non-LAG port to be redesignated as a root port and, in response, blocking the LAG port.

17. The method of claim 16, wherein the first link aggregation node device is configured to control the second link aggregation node device while the virtual port link is unavailable via a backup link to a third link aggregation node device that is included in the plurality of link aggregation node devices and that is connected to the second link aggregation node device.

18. The method of claim 14, further comprising:

creating, by the spanning tree protocol engine, a control plane group for the plurality of link aggregation node devices; and

publishing, by the spanning tree protocol engine, a control message to the control plane group such that each of the plurality of link aggregation node devices receives a copy of the control message.

19. The method of claim 14, wherein the first link aggregation node device is a primary link aggregation node device, the second link aggregation node device is a secondary link aggregation node device, and the first link

aggregation node device is the only link aggregation node device of the plurality of link aggregation node devices that is configured to control the designation of the LAG port on the second link aggregation node device.

20. The method of claim 14, wherein the determining that the non-LAG link provided between the networking device and the second link aggregation node device has caused the second virtual port to be redesignated as an alternate port and the non-LAG port to be designated as a root port includes:

determining that a State Event Machine (SEM) is attempting to assign an alternate role for the second virtual port and a root role for the non-LAG port.

* * * * *