

**(12) STANDARD PATENT**  
**(19) AUSTRALIAN PATENT OFFICE**

(11) Application No. **AU 2013231042 B1**

(54) Title  
**Add-on vehicle seat assembly**

(51) International Patent Classification(s)  
**B60N 2/005** (2006.01)                      **B60R 9/06** (2006.01)  
**B60D 1/00** (2006.01)

(21) Application No: **2013231042**                      (22) Date of Filing: **2013.09.18**

(43) Publication Date: **2014.10.09**

(43) Publication Journal Date: **2014.10.09**

(44) Accepted Journal Date: **2014.10.09**

(71) Applicant(s)  
**George Otta**

(72) Inventor(s)  
**Otta, George**

(74) Agent / Attorney  
**Spruson & Ferguson, L 35 St Martins Tower 31 Market St, Sydney, NSW, 2000**

(56) Related Art  
**US 5857741 A**  
**US 6808231 B1**  
**US 6314891 B1**  
**US 6739643 B1**

## **ADD-ON VEHICLE SEAT ASSEMBLY**

### **ABSTRACT**

An add-on seat assembly (10) is provided for temporary attachment to the rear of a vehicle. Such seating assembly (10) includes a hitch bar (12), one end of which has, intimately associated therewith, a structure and arrangement for releasable attachment to a trailer hitch which is intimately associated with the rear of a vehicle. The hitch bar (12) includes a securement structure extending across the opposed other end thereof. The seating assembly (10) includes a pair of arms (21) which are demountably rotatably attached to a respective one opposed end (27) of the securement structure. The seat assembly (10) also includes a pair of seat units, each including a seat bottom (22) which is foldably secured to a seat back (23), the bottom of the seat bottom (22) including a structure for demountably rotatably attaching the seat unit to a respective one of the pair of arms (21).

## **ADD-ON VEHICLE SEAT ASSEMBLY**

### **Field of the Invention**

[0001] The present invention relates to a seating assembly and more particularly to an add-on seating assembly. In non-limiting examples, such add-on seating assembly is structured and arranged to be attached to the rear hitch of a vehicle or to the trunk latch of a vehicle, or to the open or closed tailgate of a vehicle, or to the open trunk of a vehicle or to the bumper of a vehicle.

### **Background of the Invention**

[0002] There is often a use for seating accommodation outside a parked vehicle. One example is at sporting events, when an outdoor party or picnic occurs before the sporting event, typically in the parking lot around the vehicles. Another example is when camping or while making a stop while driving, when it is convenient to have seating outside of the vehicle to sit outdoors, for picnics or to socialize. Still another example is for outdoor sports and recreation, when it is useful to have an outdoor seating and work area to prepare equipment or sit while carrying out the activity. Yet another example is for fieldwork, such as at a construction site, when it is useful to have a convenient seating and eating area for breaks and a place to review work and papers.

[0003] One possibility for providing seating around a parked vehicle is to transport chairs in the vehicle to use at the site. However chairs require significant space and are awkward to transport. Another possibility is to use folding chairs, but the terrain around the parked car may not always be level or stable enough to set a chair on. If a table for eating or working is also required, it is not practical to also transport a table. Another possibility to provide seating that is stable is to use an apparatus that connects to the vehicle, such as an apparatus that attaches to the trailer hitch on the rear of the vehicle.

[0004] The prior art provides examples of a number of devices that are designed to mount on the trailer hitch or to the trunk latch of a vehicle or to the open or closed tailgate of a vehicle, or to the bumper of a vehicle. Among them are:

[0005] US Patent No 6,808,231, issued Oct 26, 2004 to M.L. Hill, for “Seat Assembly”, describes a device that is mounted on the vehicle hitch and incorporates a chair assembly, a fishing rod holder and a drink holder.

[0006] US Patent No 6,095,059, issued Aug 1, 2000 to W.F. Riley, for “Portable Seat Assembly” describes a portable seat assembly that can be attached to a trunk latch of a vehicle.

[0007] US Patent No 5,857,741, issued Jan 12, 1999 to T.J. Anderson, for “Tailgate Table and Chairs”, describes a tailgate table and chairs that can be mounted to a trailer hitch so that it can be used, for example, during tailgate parties.

[0008] US Patent No 5,462,334, issued Oct 31, 1995 to F.J. Sedorcek et al, for “Sport Utility Seat for Removable Attachment to an Open Truck and Bumper of an Automobile” describes a sport utility seat for removable attachment to an open truck and bumper of an automobile.

[0009] US Patent No 5,197,381, issued Mar 30, 1993 to H.M. Mells, for “Vehicle Supported, Collapsible Portable Seating Device” describes a portable, collapsible bench-like outdoor seating platform attachable to the trunk of an automobile or the to cargo bed of a pick-up truck.

[0010] US Patent No 5,000,504, issued Mar 19, 1991 to B.J. Munguia, for “Swivel Seat Attachable to a Truck Tailgate” describes a swivel seat structure that is detachably mounted on the tailgate of a pick-up truck to allow a person to sit and view outdoor activities.

[0011] US Patent No 3,865,431, issued Feb 11, 1975 to V. Zakhi, for “Vehicle Bumper Seat” describes a seat adapted to be removably attached to the bumper of a vehicle.

[0012] None of these patents provide an add-on seating assembly that can be easily assembled and attached to the rear hitch of a vehicle or to the trunk latch of a vehicle or to the open or closed tailgate of a vehicle, or to the bumper of a vehicle. Such add-on seating assembly should be easily disassembled and be able to be folded into a convenient size for carrying and stowing in the vehicle.

## Object of the Invention

[0013] It is an object of the present invention to substantially overcome or at least ameliorate one or more of the disadvantages of the prior art, or to at least provide a useful alternative.

## Summary of the Invention

[0014] Accordingly, there is provided herein an add-on seat assembly for temporary attachment to the rear of a vehicle, comprising:

- a hitch bar, one end of which has, intimately associated therewith, a hitch structure for releasable attachment to a trailer hitch intimately associated with the rear of the vehicle, the hitch bar including a securement structure extending across the opposed other end thereof;

- a pair of arms demountably and rotatably attached to a respective one opposed end of the securement structure; and

- a pair of seat units, each seat unit including a seat bottom which is foldably secured to a seat back, the bottom of the seat bottom including a seat structure for demountably and rotatably attaching the seat unit to a respective one of the pair of arms.

[0014a] There is also provided herein an add-on seat assembly for temporary attachment to the rear of a vehicle, comprising:

- a hitch bar, one end of which has, intimately associated therewith, a hitch structure for releasable attachment to a trailer hitch intimately associated with the rear of the vehicle, the hitch bar including a securement structure extending across the opposed other end thereof;

- a pair of arms demountably and rotatably attached to a respective one opposed end of the securement structure;

- a seat unit including a seat bottom that is foldably secured to a seat back, the bottom of the seat bottom including a seat structure for demountably and rotatably attaching the seat unit to a respective one of the pair of arms; and

- a second unit including a structure for demountably and rotatably attaching the second unit to a respective one of the pair of arms.

[0015] In one embodiment of the invention, the structure and arrangement of the hitch bar comprises a structure for coupling the hitch bar to a trailer hitch secured to the rear of a vehicle. By one variant thereof, the structure for coupling the hitch bar to a trailer hitch secured to the rear of a vehicle comprises a ball and socket structure. By another variant thereof, the structure for coupling the hitch bar to a trailer hitch secured to the rear of a vehicle comprises apertures in the hitch bar and apertures in the trailer hitch for insertion of a pin into mating apertures in the hitch bar and apertures in the trailer hitch. By another variant thereof, the structure and arrangement of the hitch bar comprises a structure for coupling the hitch bar to the tailgate of a vehicle that includes a horizontally-oriented attachment on the hitch bar U-shaped adapter so that the seat assembly can be attached to the closed tailgate of a vehicle. By another variant thereof, the structure and arrangement of the hitch bar comprises a structure for coupling the hitch bar to the tailgate of a vehicle that includes a vertically-oriented attachment of the hitch bar U-shaped adapter so that the seat assembly can be attached to the open tailgate of a vehicle. By another variant thereof, the structure and arrangement of the hitch bar comprises a structure for coupling the hitch bar to the tailgate of a vehicle that includes a depending “J”-hook so that

the seat assembly can be attached to the open trunk of a vehicle. By another variant thereof, the structure and arrangement of the hitch bar for coupling the hitch bar comprises a pair of vertical horizontally spaced-apart hangers for attaching the seat assembly either to the open trunk of the vehicle or the bumper of the vehicle.

[0016] In one embodiment of the invention, the structure for demountably rotatably attaching the pair of arms to a respective one opposed end of the securement structure comprises a cylindrical knob at a securement end of an arm, the cylindrical knob including a central aperture, and wherein the securement structure extending across the other end of the hitch bar includes a cooperating aperture, whereby a pin may be inserted into the cooperating apertures to provide a demountable rotatable attachment.

[0017] In one embodiment of the invention, the structure for demountably rotatably attaching the seat unit to a respective one of the pair of arms of the seat assembly comprises a cylindrical connector descending from the bottom of the seat bottom for insertion into a central aperture of a cylindrical knob at the free end of the associated one of the pair of arms, thereby to provide a demountable rotatable attachment.

[0018] In one embodiment of the invention, the edge of the seat bottom which is foldably secured to the seat back includes a tab which extends upwardly in the direction of the seat back bottom of the seat bottom for holding the seat in its erected position when the seats are not folded.

[0019] In one embodiment of the invention, the seat assembly is formed of a synthetic plastic material. By variants thereof, the synthetic plastic material may be polyethylene, or polypropylene or poly vinyl chloride.

[0020] In one embodiment of the invention, the seat assembly is formed of steel.

[0021] In one embodiment of the invention, the seat assembly is formed of rigid circular tubing, oval tubing, channel or angle shapes.

[0022] In one embodiment of the invention, the add-on seating assembly is structured and arranged to be releasably attachable to the rear hitch of a vehicle or to the trunk latch of a

vehicle or to the open tailgate of a vehicle. The seat assembly includes a hitch bar, arms and seats.

[0023] Preferably, the hitch bar is the part that is releasably mountable on the trailer hitch, or to the trunk latch of a vehicle, or to the open or closed tailgate of a vehicle which is also provided with a trailer hitch, or to the closed trunk of a vehicle which is also provided with a trailer hitch, or to the bumper of a vehicle which is also provided with a trailer hitch.

[0024] Preferably, the hitch bar has a hitch end and an outfacing end, with a hitch insert on the hitch end and a securement structure on the outfacing end. A pair of arms can be attached to the hitch bar with an upper and a lower plate of the securement structure, through a suitable mechanism e.g. a pin or bolt or other mechanical equivalent that allows the arms to swivel independently. One or more seats are provided that can be attached to the arms, in a way, as noted above, that allows the seats to swivel independently. The seats can be hinged between the seat bottom and the seat back, so that the seats can be folded.

[0025] Preferably, the add-on seating assembly allows the user to use a hitch assembly which is secured to the rear of the vehicle, or to the tailgate which is already a part of the vehicle, or to the trunk latch which is already a part of the vehicle, or to a tailgate of a vehicle which will be provided with a trailer hitch, or to a trunk of a vehicle which will be provided with a trailer hitch, or to the bumper of a vehicle which will be provided with a trailer hitch. In the embodiment where the hitch bar is attached to the hitch of a vehicle that has a tailgate, once the seating assembly is coupled to the hitch, the tailgate can be folded down and a person can sit on the seats of the seat assembly and the tailgate can now be used as a table or work bench, and one or two people can sit down and enjoy a meal and a drink at a tailgate party or rebuild a rifle on a hunting trip out in the field.

[0026] Preferably, the hitch bar and arms of the seat assembly described above are made of rigid, rectangular tubing, such as a synthetic plastic material, e.g. polyethylene or polypropylene or poly vinyl chloride plastic, or steel. However, rigid circular tubing, oval tubing, channel or angle shapes, or other materials could be equally suitable.

[0027] Preferably, one or more seats can be utilized, but the optimal design includes two seats, each of which swivels independently. Both seats may also rotate 360° independently on the outer end of the arm, so the seats can be turned towards the vehicle so the seated person can



make use of the tailgate, or the seats can be turned away from the vehicle, for example, so that a person can sit in front of a camp fire. In an alternative configuration, an attachment with a stand for a dirt bike can replace one of the seats. The bike could be set on the stand to be worked on when out riding.

[0028] Preferably, the add-on seating assembly may be disassembled and removed from the vehicle. In storage, the hitch bar and arms may be removed and folded into a compact configuration and the seats may be removed and folded into a flat configuration, thus allowing easy storage in the vehicle, either behind or under the seats or bench of a pickup truck.

### **Brief Description of the Drawings**

[0029] A preferred embodiment of the invention will be described hereinafter, by way of example only, with reference to the accompanying drawings, wherein:

[0030] Fig 1 is an isometric view of one embodiment of the seating assembly;

[0031] Fig 2 is an exploded view of the embodiment of the seating assembly shown in Fig 1;

[0032] Fig 3 is an isometric view of the hitch bar and arms of the embodiment of the seating assembly shown in Fig 1 separated from the seating assembly;

[0033] Fig 4 is an isometric view of the hitch bar and arms of the embodiment of the seating assembly shown in Fig 1 separated from the seating assembly shown in the folded position; and

[0034] Fig 5 is an isometric view of the folded seats of the seating assembly of the embodiment of the invention shown in Fig 1.

### **Detailed Description**

[0035] A preferred embodiment of this invention is shown in Figs. 1 to 2. As seen therein, the seat assembly 10 is structured and arranged to be releasably mountable to a vehicle trailer hitch. The seat assembly 10 includes a hitch bar 12 having a hitch end 13 and a rearwardly extending end 19. The hitch end 13 is structured and arranged to be removably extendible into the trailer hitch of the vehicle. A rearwardly extending outer end 19 of the hitch bar 12 is provided with an

upper cross-plate 33 and a lower cross-plate 34, each provided with a vertical aperture 30. A pin 14 is extendable into the hitch and through a selected aperture 16 of the hitch end 13 of the hitch bar 12 to hold the hitch bar 12 securely to the hitch. When the hitch end 13 is extended into the trailer hitch, the outer end 19 of the hitch bar 12 extends rearwardly from the vehicle.

[0036] A seat coupler 20 includes two structural units, namely arm 21 and seat unit comprising seat bottom 22 and seat back 23. As seen in Fig 2, the seat bottom 22 is provided with a depending cylindrical connector 24 which is adapted to be inserted onto a central aperture 25 in a cylindrical knob 26 at the outer end 27 of the arm. The inner end 28 of the arm 21 has a terminal cylindrical knob 29 which is provided with a central aperture. A pin 31 secures the arm 21 to the hitch bar 12 by being inserted into aperture 30 which communicates with the central aperture in the terminal cylindrical knob 29. In a preferred embodiment of the invention, there are two identical seat structural units.

[0037] As previously described, the seat includes a seat bottom 22 and a seat back 23. The seat back 23 is attached to, and extends upwardly from, the seat bottom 22 by a seat hinge 46 which allows the seat back 23 to fold down against the seat bottom 22. The edge of the seat bottom 22 that attaches to the seat back 23 has a tab 47 attached which extends upward in the direction of the seat back 23 and holds the seat back 23 in its erected position when the seats are not folded.

[0038] The seat assembly 10 is shown in the assembled position in Fig 1 and the sequence of assembly is shown in Fig 2. In that sequence, the hitch end 13 is inserted into the trailer hitch and the hitch pin 14 anchors it in place. The appropriate hitch bar aperture 16 is used so that the tailgate of the vehicle can be lowered (not shown). The structural units comprising arm 21 and seat unit comprising seat bottom 22 and seat back 23 are secured to the rearwardly extending end of the hitch bar 19 as previously described by means of pins 31 into apertures 30. The seat comprising seat bottom 22 and seat back 23 is rotatably mounted to the arms 21 by means of cylindrical connector 24 being inserted into aperture 25 of knob 26.

[0039] The seat assembly 10 is disassembled in the reverse order which will be clear from the above description.

[0040] The seat assembly 10 is folded for storage as shown in Fig 3 to 5.

[0041] Fig 3 shows the frame unit comprising only hitch bar 12 and two arms 21 in a “Y”-shaped configuration.

[0042] Fig 4 shows the frame unit comprising only hitch bar 12 and two arms 21 in a parallel configuration with the hitch bar 12 between the two arms 21.

[0043] Fig 5 shows the seat unit comprising seat back 23 and seat bottom 22 in a folded configuration for storage.

[0044] In use, the seat assembly 10 is attached to a trailer hitch of a vehicle. Once the seat assembly is so attached, the user sits on a seat bottom 22 of the seat assembly. The seat unit can swivel on the outer end 27 of the arm 21 to allow the user to face away from the vehicle, or to face toward the vehicle and allow the user to use the tailgate as a working or eating surface. The arm 21 can also swivel on the hitch bar 12, allowing the user to be positioned closer to or farther away from the vehicle.

[0045] With respect to the above description, it is to be realized that the optimum variations in materials, shape and form are deemed readily apparent and obvious to one skilled in the art, and all equivalent relationships to those illustrated in the drawings and described in the specification are intended to be encompassed by aspects of the present invention.

[0046] Therefore, the foregoing is considered as illustrative only of the principles of the assembly. Further, since numerous modifications and changes will readily occur to those skilled in the art, it is not desired to limit the seat assembly to the exact construction and operation shown and described, and accordingly all suitable modifications and equivalents may be resorted to, falling within the scope of the assembly.

## CLAIMS

1. An add-on seat assembly for temporary attachment to the rear of a vehicle, comprising:
  - a hitch bar, one end of which has, intimately associated therewith, a hitch structure for releasable attachment to a trailer hitch intimately associated with the rear of the vehicle, the hitch bar including a securement structure extending across the opposed other end thereof;
  - a pair of arms demountably and rotatably attached to a respective one opposed end of the securement structure; and
  - a pair of seat units, each seat unit including a seat bottom which is foldably secured to a seat back, the bottom of the seat bottom including a seat structure for demountably and rotatably attaching the seat unit to a respective one of the pair of arms.
  
2. An add-on seat assembly for temporary attachment to the rear of a vehicle, comprising:
  - a hitch bar, one end of which has, intimately associated therewith, a hitch structure for releasable attachment to a trailer hitch intimately associated with the rear of the vehicle, the hitch bar including a securement structure extending across the opposed other end thereof;
  - a pair of arms demountably and rotatably attached to a respective one opposed end of the securement structure;
  - a seat unit including a seat bottom that is foldably secured to a seat back, the bottom of the seat bottom including a seat structure for demountably and rotatably attaching the seat unit to a respective one of the pair of arms; and
  - a second unit including a structure for demountably and rotatably attaching the second unit to a respective one of the pair of arms.
  
3. The seat assembly as claimed in claim 1 or 2, wherein the hitch structure is adapted to couple the hitch bar to the trailer hitch secured to the rear of the vehicle.
  
4. The seat assembly as claimed in claim 1 or 2, wherein the hitch structure comprises apertures in the hitch bar and apertures in the trailer hitch for insertion of a pin into mating apertures in the hitch bar and apertures in the trailer hitch.
  
5. The seat assembly as claimed in any one of claims 1 to 4, wherein each arm is demountably and rotatably attached to the respective one opposed end of the securement structure by an arm attachment structure, the arm attachment structure comprises a cylindrical knob at a securement end of the arm, the cylindrical knob including a central aperture, and

wherein the securement structure extending across the hitch bar includes a cooperating aperture, whereby a pin may be inserted into the cooperating apertures thereby to provide a demountable and rotatable attachment.

6. The seat assembly as claimed in any one of claims 1 to 5, wherein the seat structure comprises a cylindrical connector descending from the bottom of the seat bottom for insertion into a central aperture of a cylindrical knob at the free end of the associated one of the pair of arms, thereby to provide a demountable rotatable attachment.

7. The seat assembly as claimed in any one of claims 1 to 6, wherein the edge of the seat bottom which is foldably secured to the seat back includes a tab which extends upwardly in the direction of the seat back for holding the seat unit in its erected position when the seats are not folded.

8. The seat assembly as claimed in any one of claims 1 to 7, wherein the seat assembly is formed of a synthetic plastic material.

9. The seat assembly as claimed in claim 8, wherein the synthetic plastic material is polyethylene.

10. The seat assembly as claimed in claim 8, wherein the synthetic plastic material is polypropylene.

11. The seat assembly as claimed in claim 8, wherein the synthetic plastic material is poly vinyl chloride.

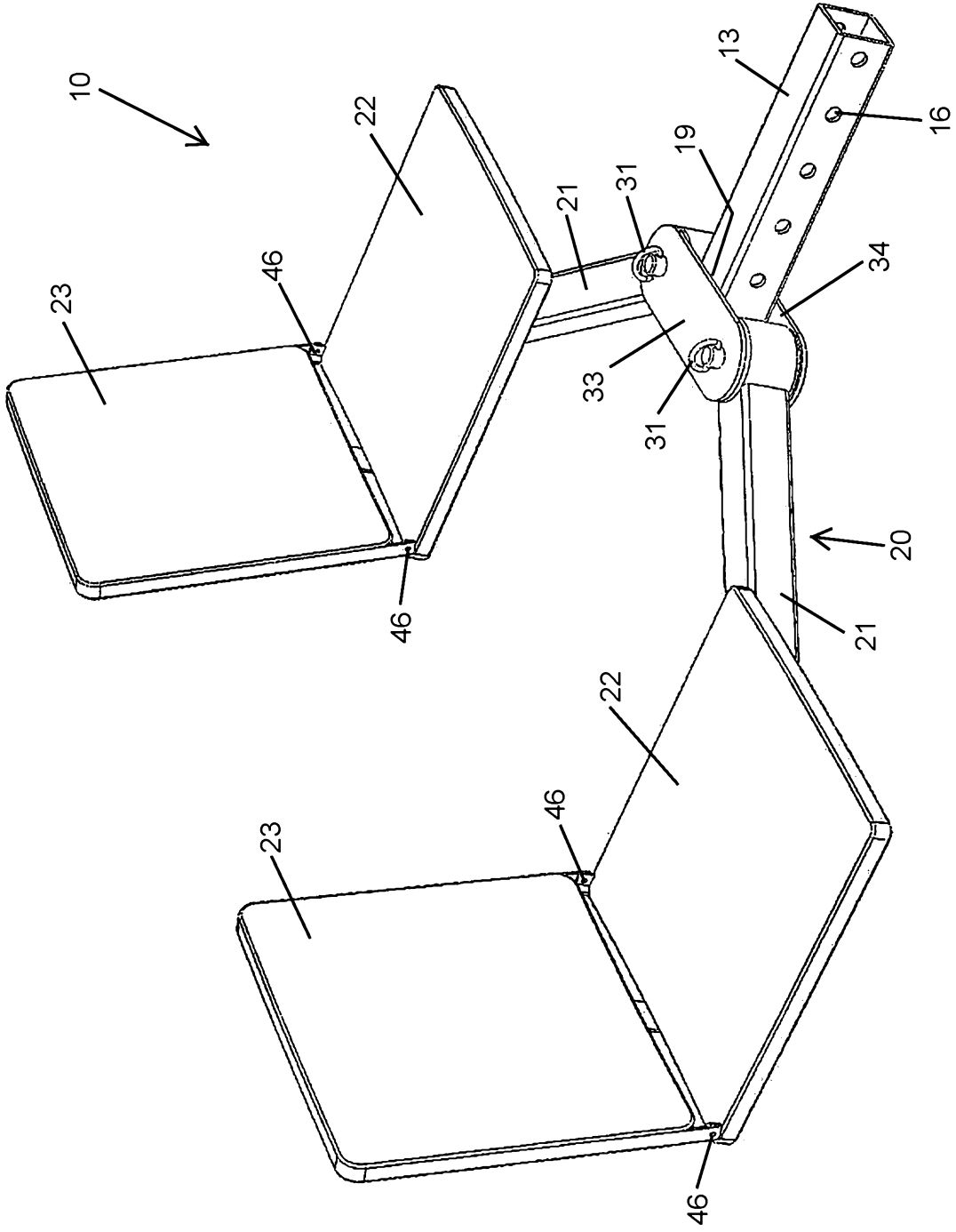
12. The seat assembly as claimed in any one of claims 1 to 7, wherein the seat assembly is formed of steel.

13. The seat assembly as claimed in any one of claims 1 to 12, wherein the seat assembly is formed of rigid circular tubing, oval tubing, channel or angle shapes.

**George Otta**

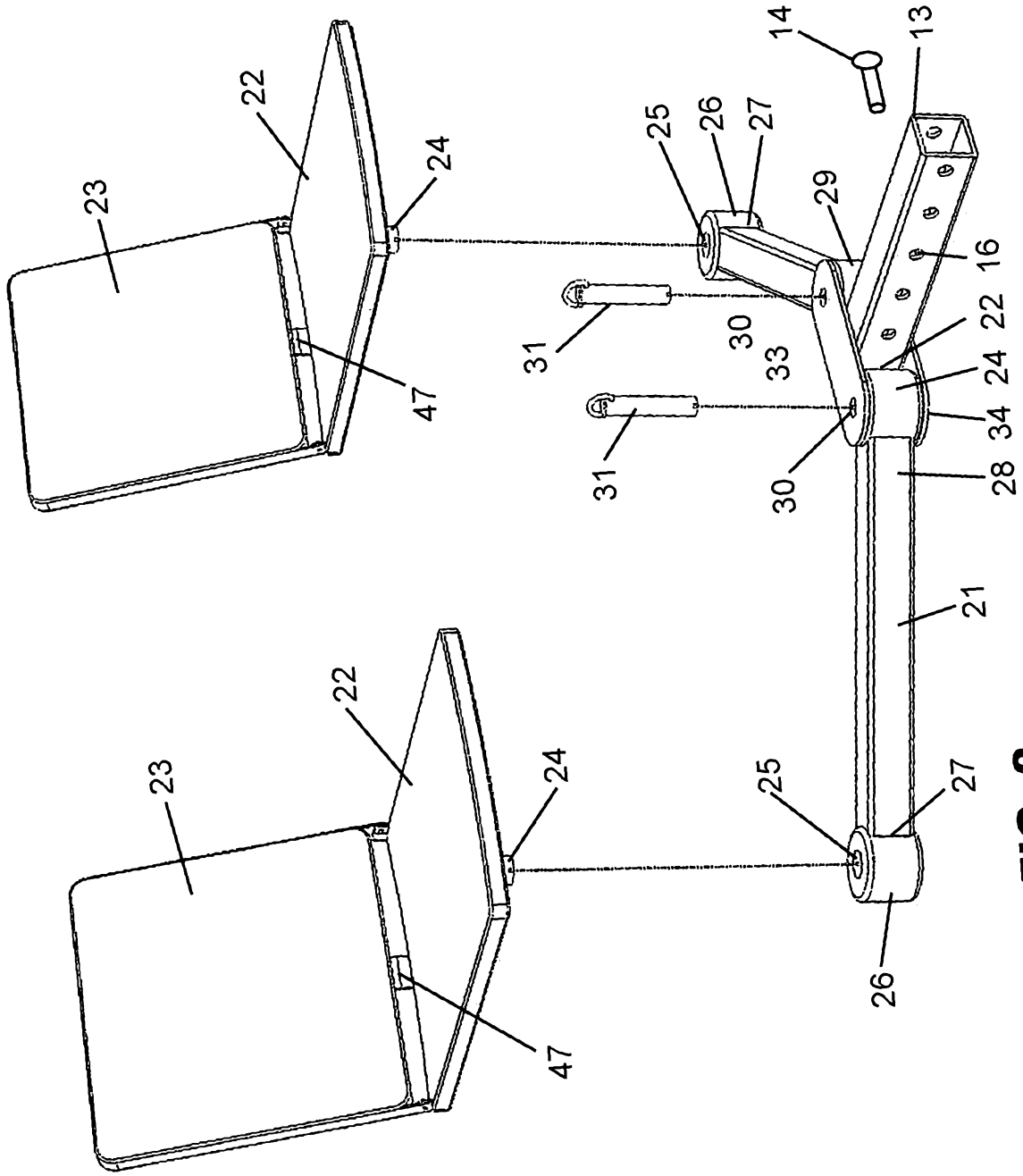
**Patent Attorneys for the Applicant/Nominated Person**

**SPRUSON & FERGUSON**



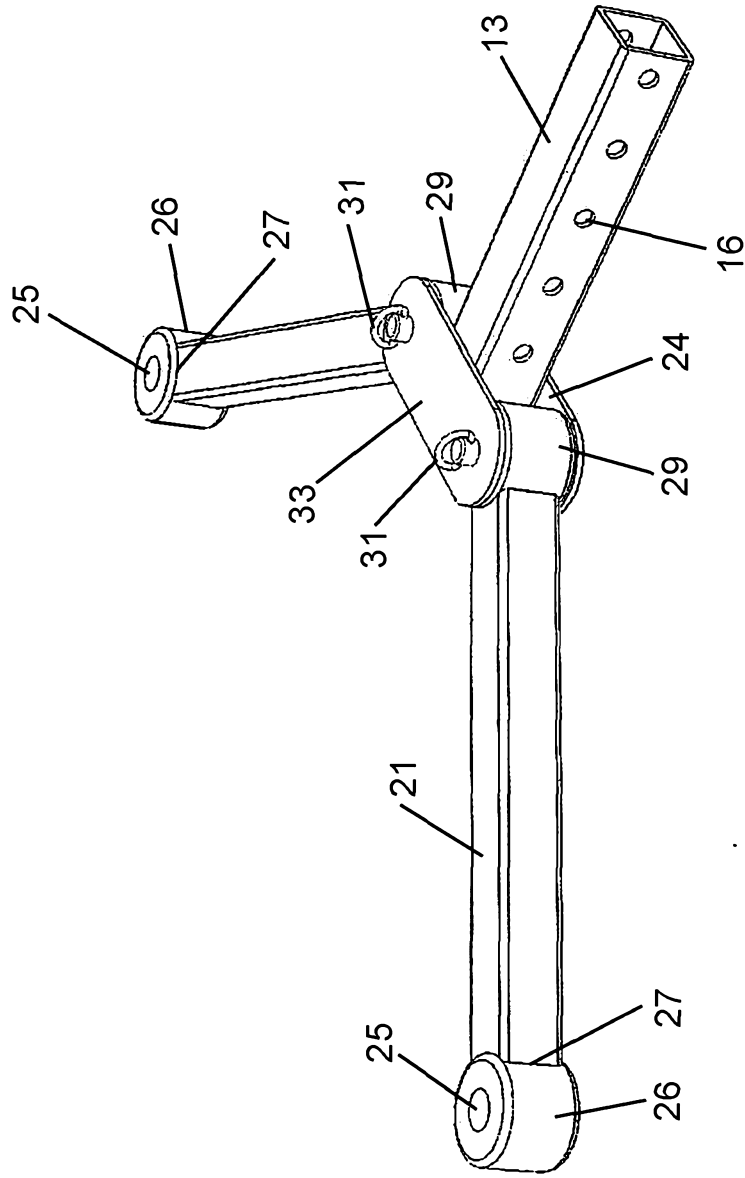
**FIG. 1**





**FIG. 2**

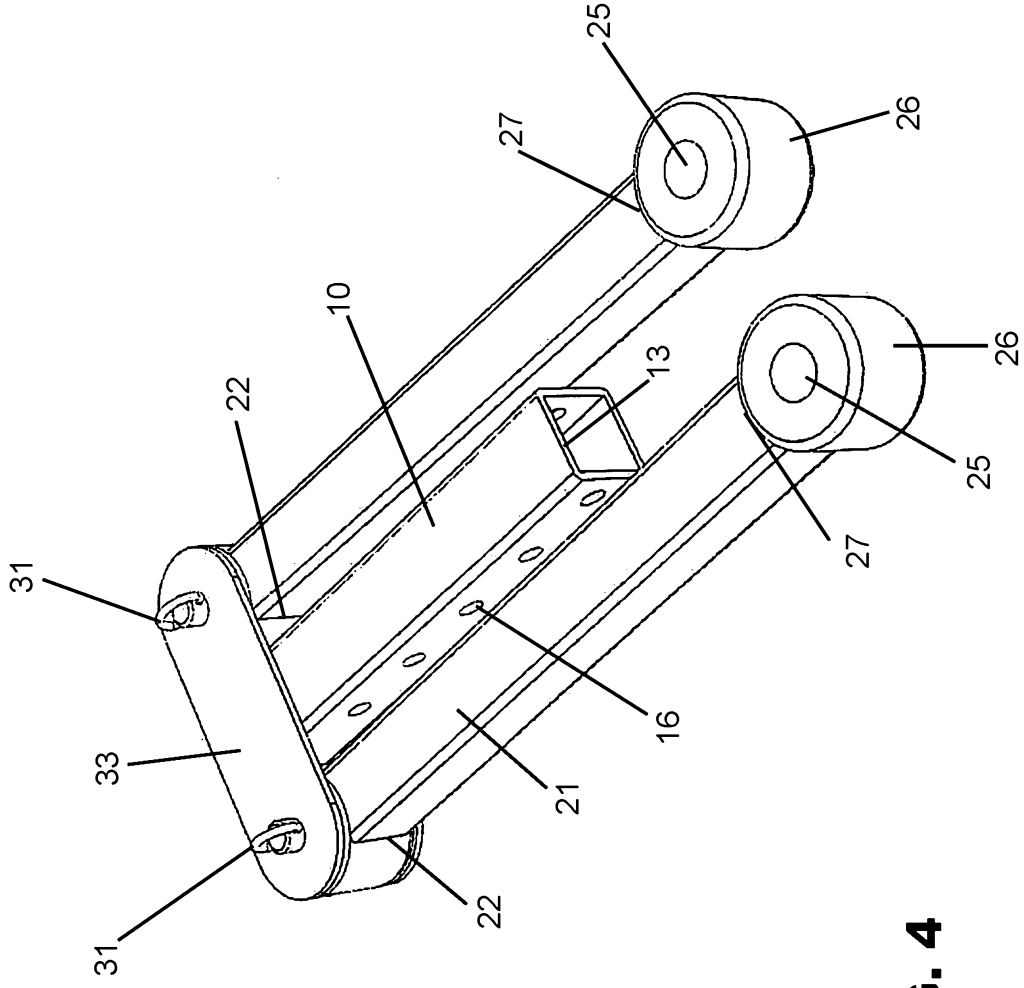




**FIG. 3**







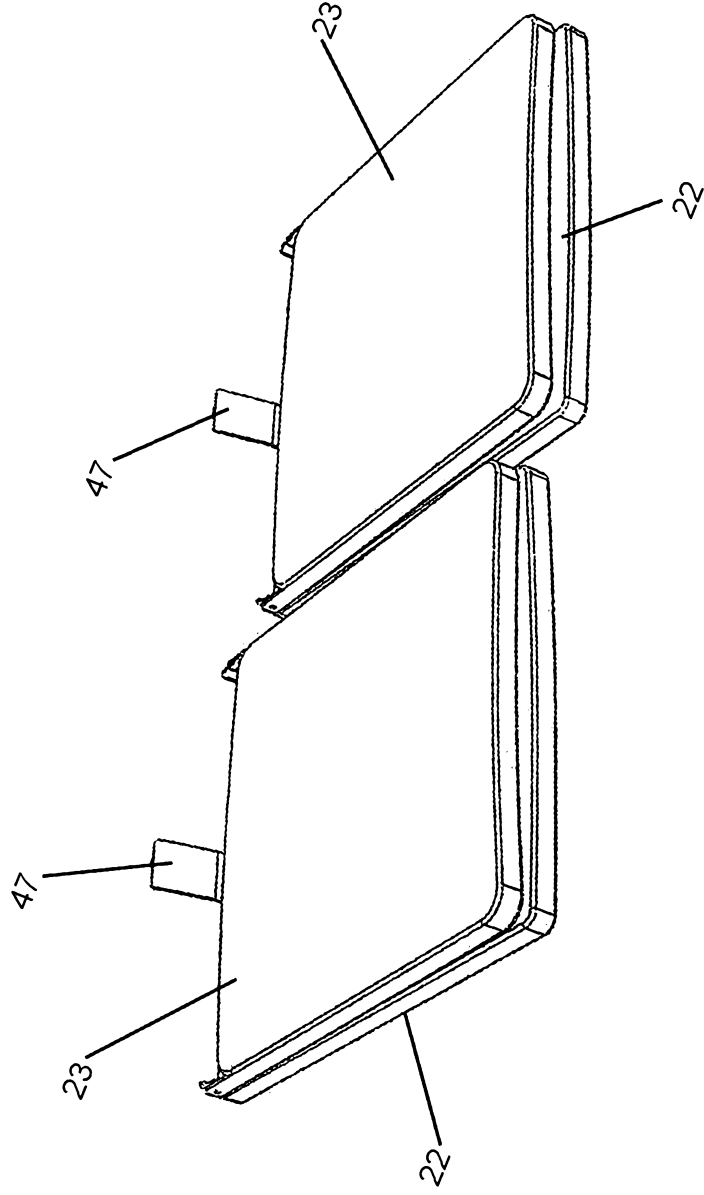
**FIG. 4**



2013231042

18 Sep 2013

5/5



**FIG. 5**