



US 20150081146A1

(19) **United States**

(12) **Patent Application Publication**

Geder et al.

(10) **Pub. No.: US 2015/0081146 A1**

(43) **Pub. Date: Mar. 19, 2015**

(54) **ACTIVELY CONTROLLED CURVATURE
ROBOTIC PECTORAL FIN**

Publication Classification

(71) Applicant: **US Gov't Represented by the
Secretary of the Navy Chief of Naval
Research ONR/NRL, Washington, DC
(US)**

(51) **Int. Cl.**
B63H 1/37 (2006.01)
B63H 5/00 (2006.01)
(52) **U.S. Cl.**
CPC .. *B63H 1/37* (2013.01); *B63H 5/00* (2013.01);
Y10S 901/01 (2013.01)
USPC **701/21; 901/1**

(72) Inventors: **Jason D. Geder, Arlington, VA (US);
John S. Palmisano, Silver Spring, MD
(US); Marius D. Pruessner, Silver
Spring, MD (US); Ravi Ramamurti,
Silver Spring, MD (US)**

(57) **ABSTRACT**

A robotic mechanical fin, having a motor housing containing a plurality of rib rotation motors, rib spars, and a plurality of ribs, mechanically movable and communicatively coupled to the plurality of rib rotation motors and shafts, where the plurality of ribs are rotationally coupled to and actuated by the plurality of rib rotation motors and shafts. The mechanical fin further includes a flexible fin casing, within which the ribs reside, forming the complete actively controlled curvature robotic propulsion and steering apparatus. The mechanical fin, is connected to a plurality of control electronics circuits and a computer processor programmed with actuation code that when executed by the computer processor causes automated actuation of simultaneous propulsion and steering maneuverability of the actively controlled curvature, robotic, mechanical fin.

(73) Assignee: **US Gov't Represented by the
Secretary of the Navy Chief of Naval
Research ONR/NRL, Washington, DC
(US)**

(21) Appl. No.: **13/987,921**

(22) Filed: **Sep. 17, 2013**

ACTIVELY CONTROLLED CURVATURE ROBOTIC FIN 100

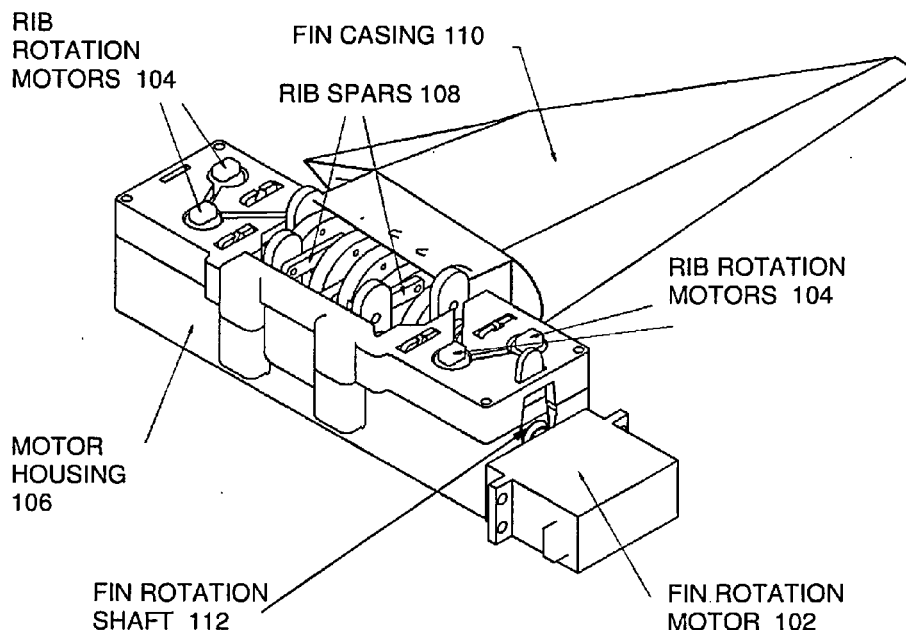

ACTIVELY CONTROLLED CURVATURE ROBOTIC FIN 100

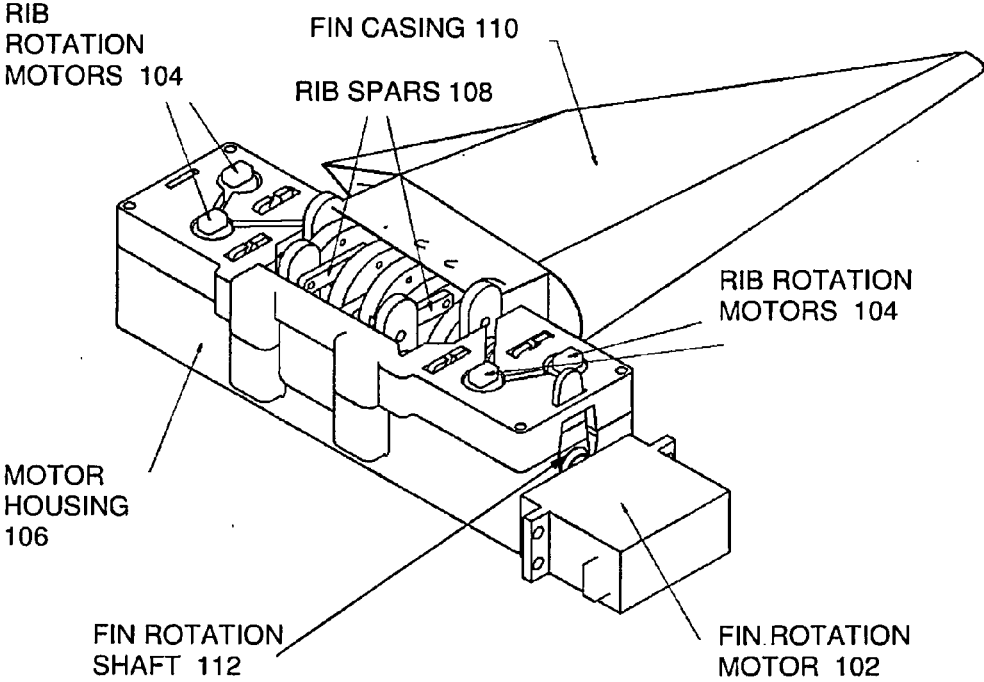

FIG. 1

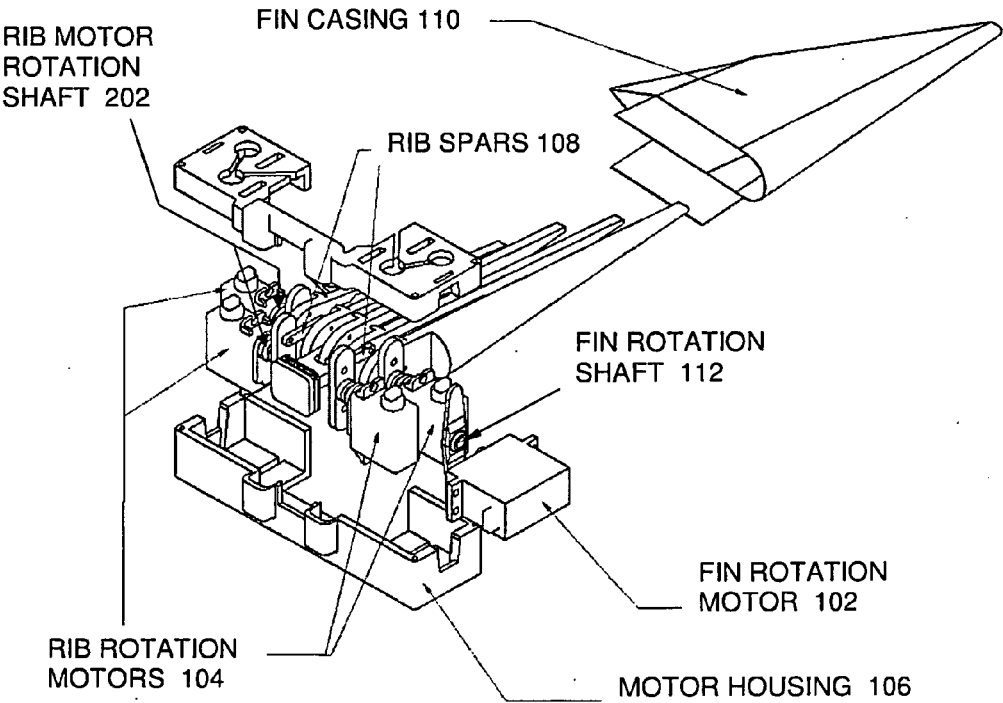

FIG. 2

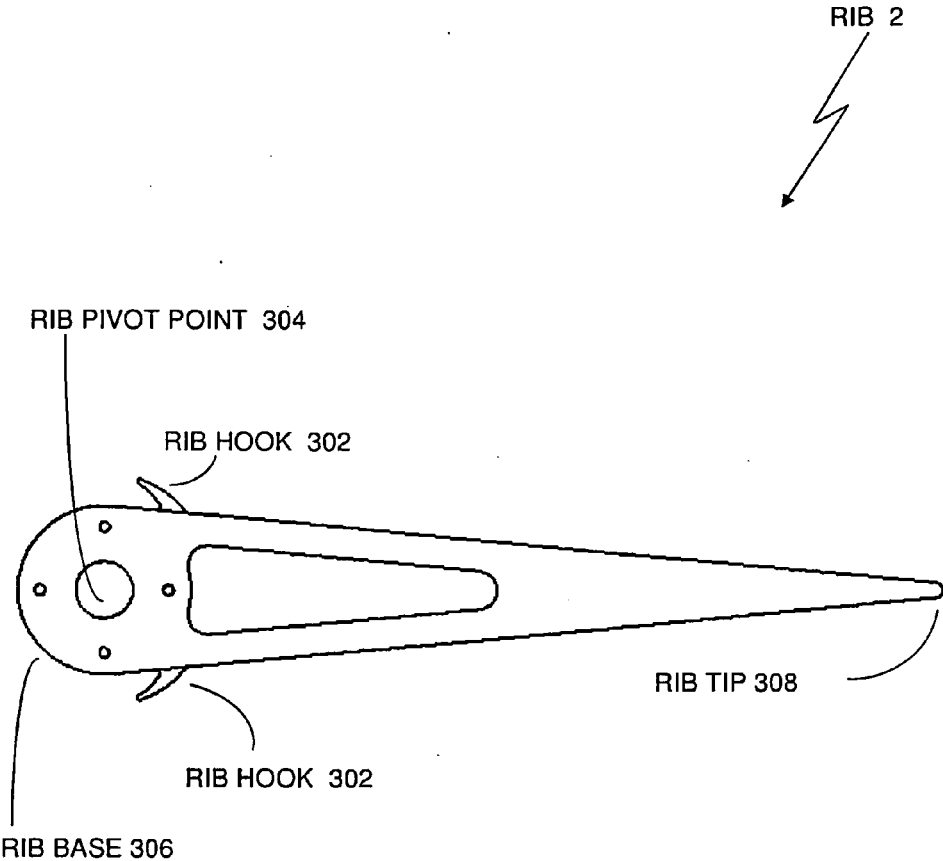

FIG. 3

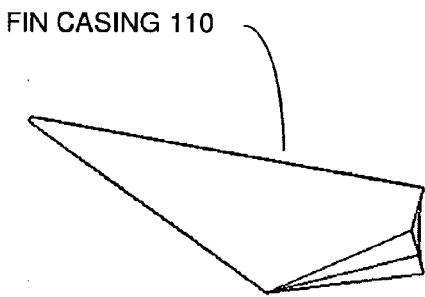

FIG. 4A

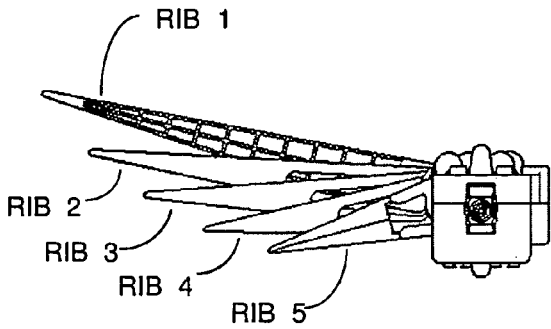
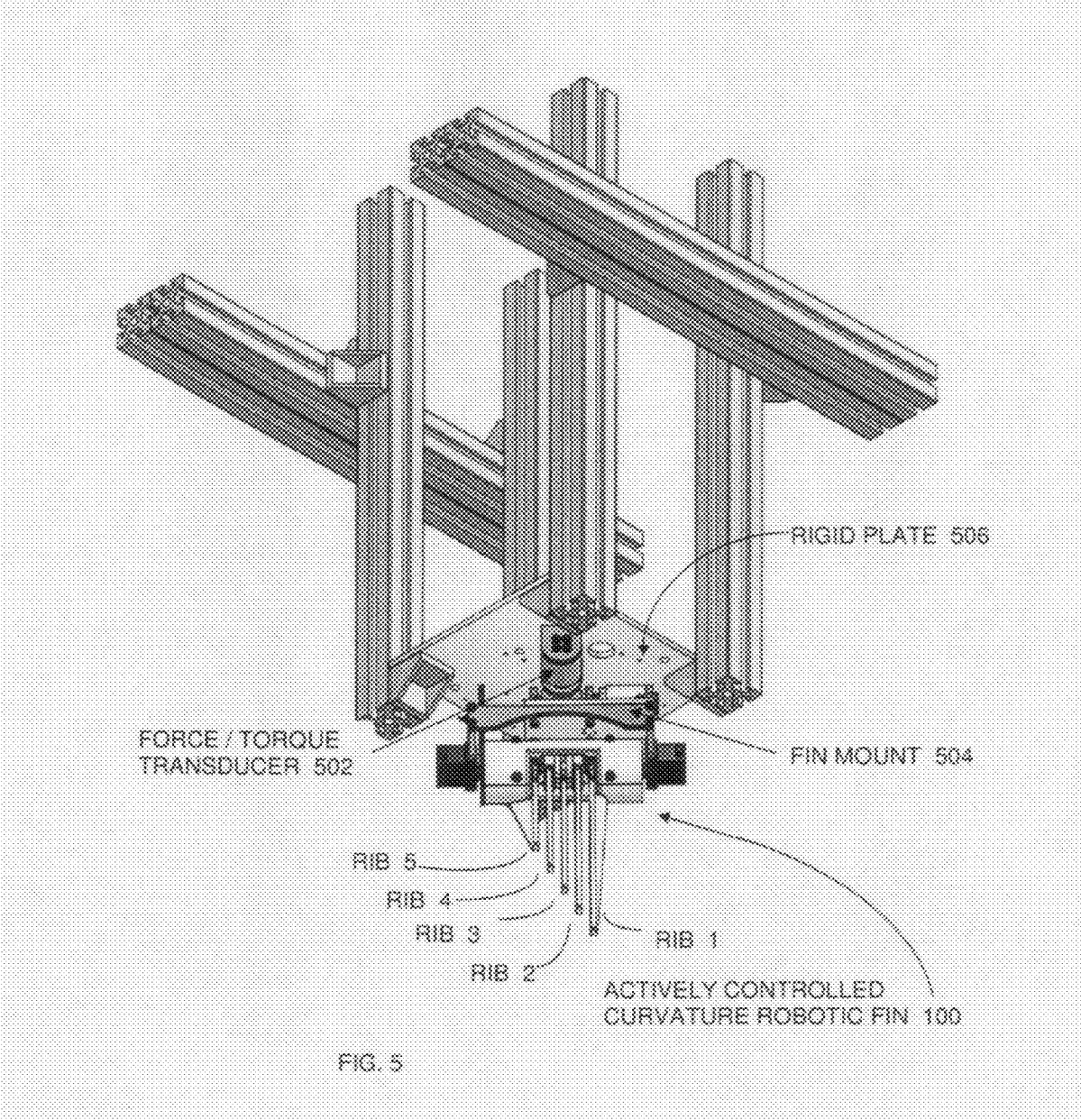

FIG. 4B



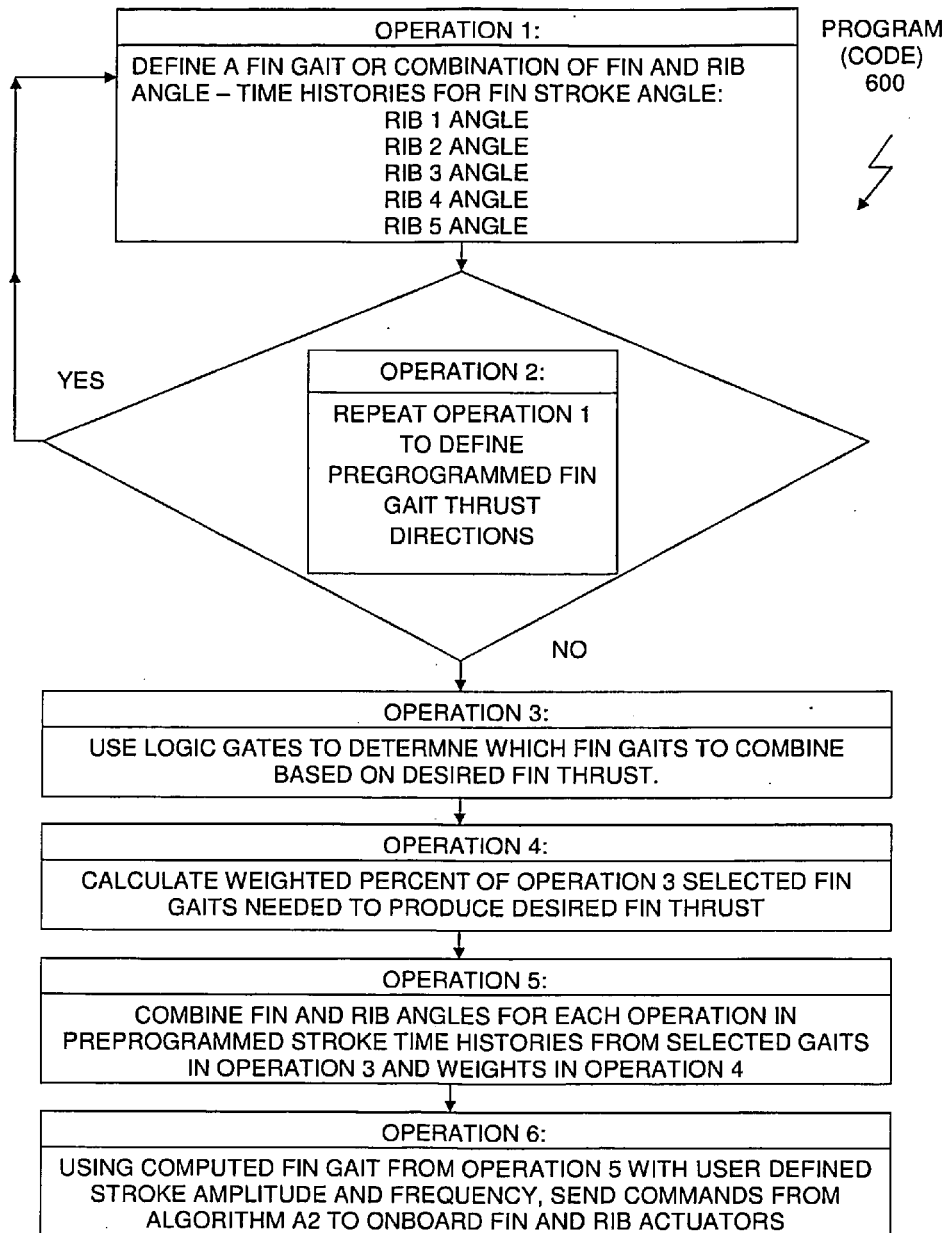

FIG. 6

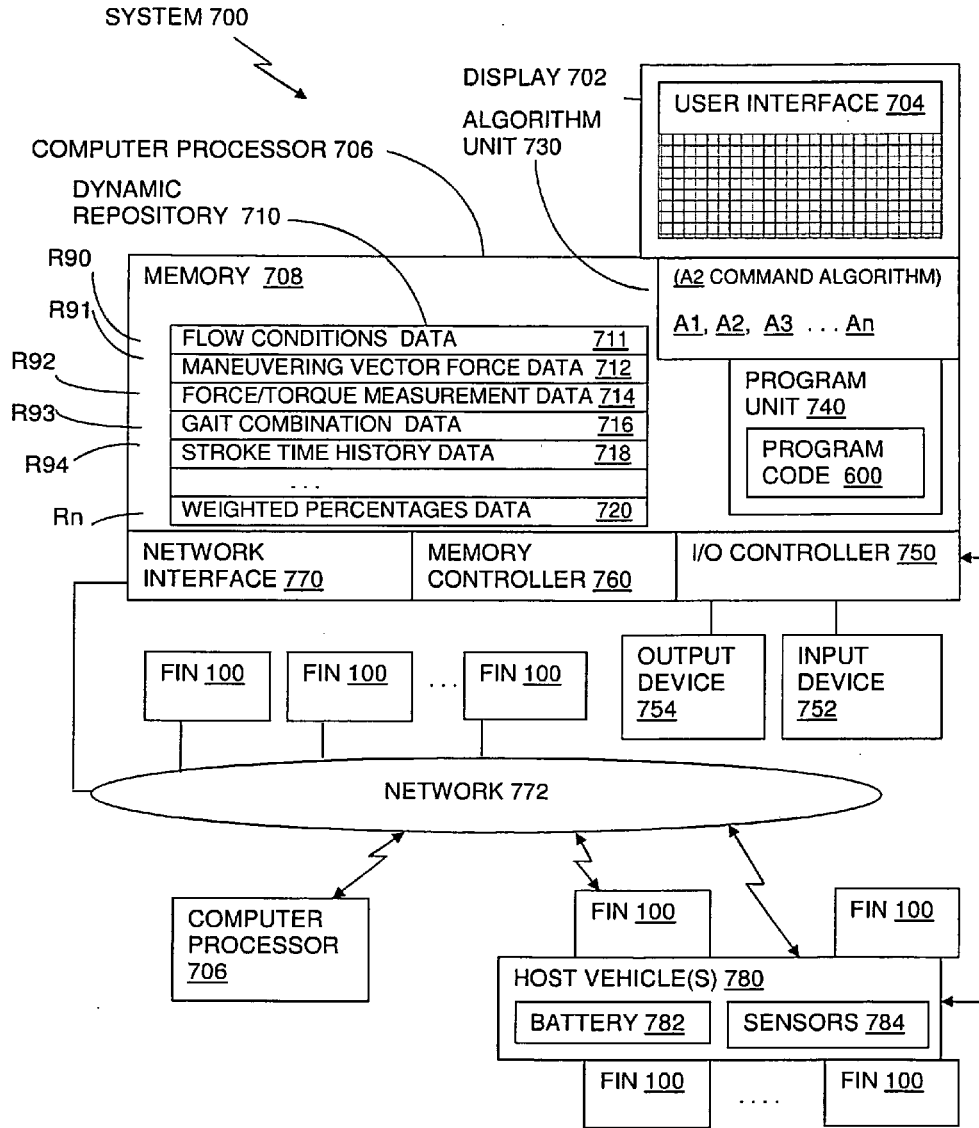

FIG. 7

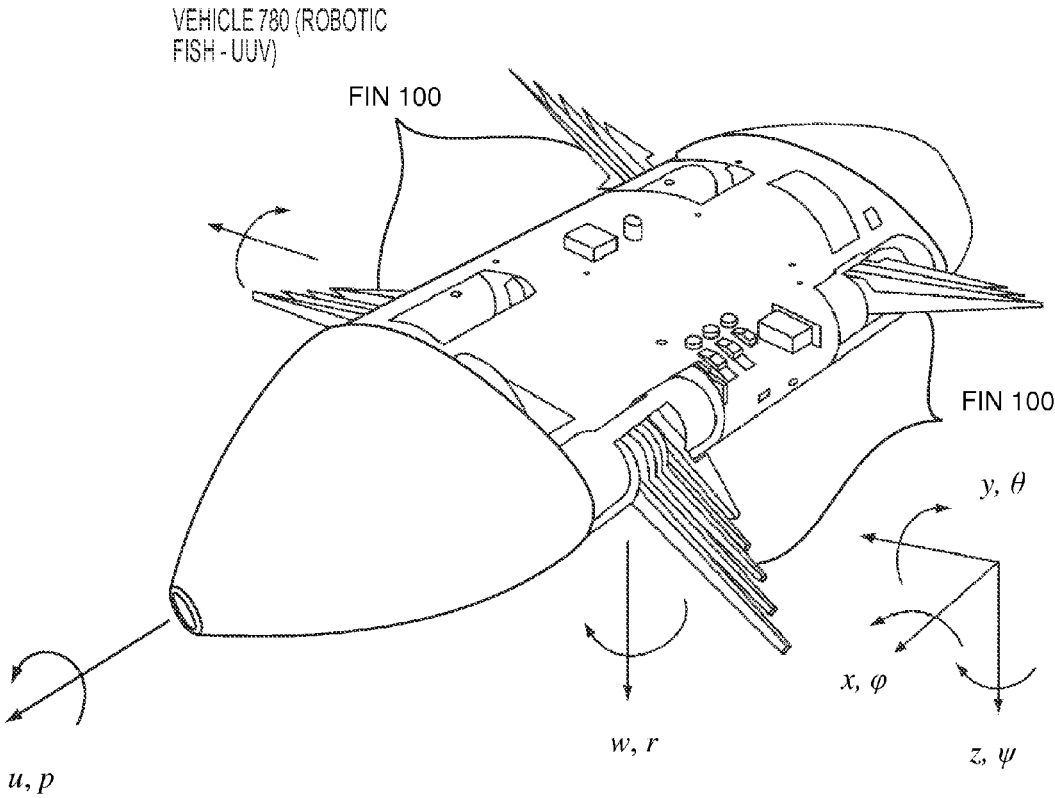

FIG.8

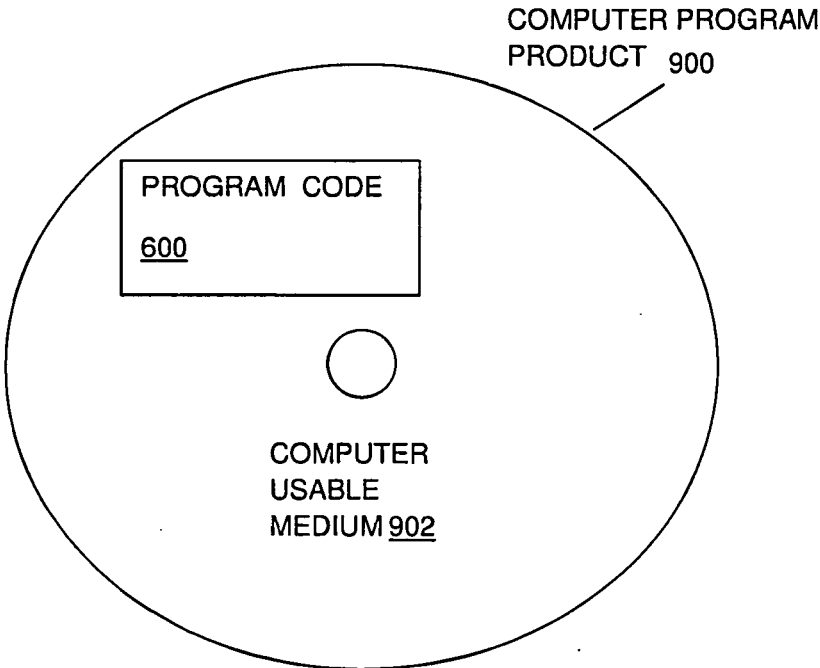

FIG. 9

ACTIVELY CONTROLLED CURVATURE ROBOTIC PECTORAL FIN

FIELD OF THE INVENTION

[0001] The present application relates to a fin used to generate propulsion and control forces for a vehicle in an underwater or water surface environment. More particularly, the instant application discloses a propulsion fin which can actively change its curvature during flapping stroke cycles and thus provides a single mechanism through which directional control over propulsive forces can be achieved.

BACKGROUND OF THE INVENTION

[0002] The subject matter of this patent application disclosure has wide application to maritime propulsion, steering and direction control systems for underwater vehicles and vehicles which traverse surface waters.

[0003] Known methods of force production for propulsion and control of underwater and surface vehicles use rotating propellers, and/or rigid or passively deforming fins.

[0004] There are many undersea areas in which traditional propulsion and sensing techniques have proven effective for unmanned systems, but such undersea areas have mostly been in open waters.

[0005] Rotating propellers have limitations in force production at slow speeds and in highly dynamic environments where water flows are constantly changing. Additionally, a propeller on its own can only be used to propel a vehicle. It would require multiple non-coaxial propellers or a system of control surfaces for steering and directional control. Propellers also have disadvantages in certain environments as they are noisy, and can be adversely affected by interference of debris, such as near-shore vegetation.

[0006] Researchers seeking to improve on vehicle performance in cluttered undersea areas with fast changing currents and near-surface wave effects draw inspiration from fish and other aquatic organisms which inhabit these types of environments, where unmanned platforms could prove to be very useful. Combinations of finned propulsion and control surface actuation, and unique sensory systems provide these organisms the abilities they need to survive and thrive.

[0007] According to J. E. Colgate et al. "Mechanics and control of swimming: a review," IEEE Journal of Oceanic Engineering, vol. 29, pp. 660-673, July 2004 and J. C. Liao, "A review of fish swimming mechanics and behavior in altered flows," Philosophical Transactions of the Royal Society B. vol. 362(1487), pp. 1973-1993, November 2007, a number of researchers have studied the fin force production mechanisms of fish. Several investigators have developed and adapted rigid and passively deforming robotic pectoral fins onto unmanned underwater vehicles (UUV's) including B. Hobson, et al. "PilotFish: Maximizing agility in an unmanned underwater vehicle," Proceedings of the International Symposium on Unmanned Untethered Submersible Technology, Durham, N.H., 1999; S. Licht, et al. "Design and projected performance of a flapping foil AUV," IEEE Journal of Oceanic Engineering, vol. 29, no. 3, 2004; P. Sitorus, et al. "Design and implementation of paired pectoral fins locomotion of labriform fish applied to a fish robot," Journal of Bionic Engineering, vol. 6, pp. 37-45, 2009; and N. Kato, et al., "Elastic pectoral fin actuators for biomimetic underwater vehicles," in Bio-mechanisms of Swimming and Flying, chap. 9, Springer Japan, 2008, pp. 271-282.

[0008] Other investigators have sought to develop actively controlled curvature pectoral fins including N. Kato, et al., "Elastic pectoral fin actuators for biomimetic underwater vehicles," in Bio-mechanisms of Swimming and Flying, chap. 9, Springer Japan, 2008, pp. 271-282; J. Palmisano, et al., "Design of a biomimetic controlled-curvature robotic pectoral fin," IEEE International Conference on Robotics and Automation, Rome, Italy, 2007; K. W. Moored et al., "Investigating the thrust production of a myliobatoid-inspired oscillating wing," 3rd International CIMTEC Conference, Acireal, Italy, Jun. 8-13, 2008; and J. Tangorra et al., "The effect of fin ray flexural rigidity on the propulsive forces generated by a biorobotic fish pectoral fin," The Journal of Experimental Biology, vol. 213, pp. 4043-4054, 2010.

[0009] Thus, rigid and passively deforming fins have a limitation in force production control, as there are fewer degrees of freedom which can be actuated, and thus less control over the direction of force production. Further, passively deforming fins generally require a trial-and-error method of determining shape deformation under loads.

[0010] A fin that can actively change its curvature during flapping stroke cycles provides a single mechanism through which directional control and through which propulsive forces can be achieved simultaneously. The instant invention provides a fin having an effector of propulsion and control that will not be damaged when operating in vegetation or other debris, such as in near shore environments where precise low-speed maneuvering is needed. It also enables greater control in flow-changing environments than traditional propellers and rigid/passive fins as the fin surface shape can be changed to take advantage of data involving a multitude of flow conditions. Therefore, the need exists for a fin that can actively change its curvature during flapping stroke cycles. Further, the need exists for a fin which provides a single mechanism through which directional control over propulsive forces can be achieved. In addition, the need exists for a fin which also provides an effector of propulsion and control that will not be damaged when operating in vegetation or other debris. Finally, the need exists for a fin which enables greater control in flow-changing environments contrasted with traditional propellers and rigid/passive fins as the fin surface shape can be changed to take advantage of a multitude of flow conditions.

SUMMARY OF THE INVENTION

[0011] An actively controlled curvature, robotic propulsion, and steering apparatus, having elements including: a motor housing containing a plurality of rib rotation motors, having connecting and motion transferring shafts, rib spars, and a plurality of ribs, mechanically movable and communicatively coupled to the plurality of rib rotation motors and connecting motor shafts, where the plurality of ribs includes a plurality of rib spars connected between the plurality of ribs and the plurality of rib rotation motors, rotationally coupled to and/or actuated by the plurality of rib rotation motors and connecting shafts. The actively controlled curvature, robotic propulsion, and steering apparatus further includes a flexible fin casing, within which the ribs reside, forming the complete actively controlled curvature robotic propulsion and steering apparatus. In addition, the actively controlled curvature robotic propulsion and steering apparatus can be characterized as a mechanical fin. The mechanical fin, further contains a plurality of control electronics circuits and a computer processor or a plurality of computer processors containing

and/or programmed with actuation code when executed by the computer processor causing automated actuation propulsion and steering maneuverability of the actively controlled curvature robotic mechanical fin.

[0012] The computer processor and the plurality of control electronics circuits can be communicatively connected by a communication protocol over a communication network, to the mechanical fin. The computer processor and the plurality of control electronics circuits can be either residing in the mechanical fin or residing remotely and/or external to the mechanical fin, over either a direct data communications network connection or a remote wireless data communications network connection. The plurality of control electronics circuits can include at least an input device an output device, sensors, transducers, and/or keyboards.

[0013] The mechanical fin, when actuated, generates a plurality of gait propulsion forces and a plurality of directional steering forces, in various media including fluid, liquid and gaseous media, corresponding to a plurality of fin stroke amplitudes, a plurality of fin stroke frequencies and a plurality of fin rib deflections creating a plurality of velocity vectors including drag and thrust directional steering maneuverability vectors within the various media elements. Where the media can include liquids, such as water, oil, or a colloidal mixture of elements (including icy water), and air or other gases.

[0014] The plurality of fin rib deflections and the plurality of gait propulsion forces and the plurality of directional steering forces and the plurality of fin stroke amplitudes and the plurality of fin stroke frequencies cause the mechanical fin to actively change curvature and perform a continuous flapping motion simultaneously to operate in changing flow conditions of the various media.

[0015] Any number of the mechanical fin and/or fins forming a plurality of mechanical fins can be attached to a platform, forming a vehicle and actuation of the mechanical fin and/or the plurality of fins, when actuated by the executed code in the associated computer processor(s) cause the vehicle to maneuver and/or hover in the various media.

BRIEF DESCRIPTION OF THE DRAWINGS

[0016] FIG. 1 illustrates an assembled, actively controlled curvature, robotic fin.

[0017] FIG. 2 illustrates an exploded view of the actively controlled curvature robotic fin, illustrated in FIG. 1.

[0018] FIG. 3 illustrates an individual rib (RIB 2) of the actively controlled curvature robotic fin.

[0019] FIG. 4A illustrates a fin casing.

[0020] FIG. 4B illustrates an assemblage of a plurality of ribs within a motor housing. This configuration of the plurality of ribs is in conformance with the fin casing illustrated in FIG. 4A.

[0021] FIG. 5 illustrates a fin force test stand including a fin mount, and a fin mounted on the fin mount and a force/torque transducer.

[0022] FIG. 6 illustrates operations defining the kinematics for each fin of a plurality of fins.

[0023] FIG. 7 illustrates a schematic of automated micro-controllers, computers and computer processors, in conjunction with proprietary control software and proprietary software drivers associated with control electronics circuits in the actively controlled curvature robotic fin 100, which cause the control electronics to actuate rib (i.e., Rib 1, Rib 2, Rib 3, Rib 4, and Rib 5) motions.

[0024] FIG. 8 illustrates coordinate inertial reference frames of (robotic fish) vehicle 780.

[0025] FIG. 9 illustrates an exemplary computer readable and computer executable medium 902 containing a computer program product 900 including method operations included in program code 600 executed on a system 700, implementing robotic fin actuation in platform vehicle 780.

DETAILED DESCRIPTION

[0026] Preferred exemplary embodiments of the present invention are now described with reference to the figures, in which like reference numerals are generally used to indicate identical or functionally similar elements. While specific details of the preferred exemplary embodiments are discussed, it should be understood that this is done for illustrative purposes only. A person skilled in the relevant art will recognize that other configurations and arrangements can be used without departing from the spirit and scope of the preferred exemplary embodiments. It will also be apparent to a person skilled in the relevant art that the exemplary embodiments can also be employed in other applications. Further, the terms “a”, “an”, “first”, “second” and “third” etc. used herein do not denote limitations of quantity, but rather denote the presence of one or more of the referenced items(s).

[0027] The assembled actively controlled curvature robotic fin 100 is shown in FIG. 1. The exploded view of the actively controlled curvature robotic fin 100 is shown in FIG. 2. The actively controlled curvature robotic fin 100 consists of fin rotation motor(s) 104, rib rotation motor(s) 102, motor housing 106, rib spar(s) 108, ribs (including Rib 1, Rib 2, Rib 3, Rib 4, Rib 5) and fin casing 110.

[0028] One of the rib spars 108 is shown in FIG. 3. The rib(s), such as Rib 2, have a tapered shape from rib base 306 to rib tip 308, and have a pivot point 304 near the rib base 306, and have rib hook(s) 302 built into the top and bottom of the rib (such as Rib 2), designed to attach the ribs (i.e., Rib 1, Rib 2, Rib 3, Rib 4, and Rib 5) to the fin casing 110, where the surface of the fin casing 110 is composed of flexible material, which can change shape to conform to the various deflections of the ribs, such as Rib 1, Rib 2, Rib 3, Rib 4, and/or Rib 5.

[0029] FIG. 4A illustrates the fin casing 110. Independent rib deflections (i.e., Rib 1, Rib 2, Rib 3, Rib 4, and Rib 5) are shown in FIG. 4B. Each of the rib spars 108 can be independently deflected to a different angle from the others, and these deflections define the shape of the fin casing 110 surface. Thus, FIG. 4B illustrates an assemblage of a plurality of rib spars 108 and ribs (i.e., Rib 1, Rib 2, Rib 3, Rib 4, and Rib 5) within the motor housing 106. This configuration of the plurality of rib spars is associated with a plurality of ribs, such as at least Rib 1, Rib 2, Rib 3, Rib 4, and Rib 5 and the number of ribs (i.e., Rib 1, Rib 2, Rib 3, Rib 4, and Rib 5) can include at least one or more ribs, (such as Rib 1, Rib 2, Rib 3, Rib 4, and Rib 5), limited only by the number of rib spars 108 configured within the motor housing 106 and the physical size of the motor housing 106. It is important to note the not all ribs have rib spars 108 attached; some ribs are connected directly to the rib rotation motor(s). Additionally, ribs (i.e., Rib 1, Rib 2, Rib 3, Rib 4, and Rib 5) can be any number of different sizes. A configuration of the plurality of rib spars 108 in FIG. 4B is in conformance with the fin casing 110 illustrated in FIG. 4A.

[0030] Referring to FIG. 1, FIG. 2, FIG. 3 and FIG. 4A, the motor housing 106 consists of two pieces which are pressed together and screwed down to clamp the rib rotation motors

104 in place. Additionally, a servo horn attached to the fin rotation shaft **112** of the fin rotation motor **102** is secured by the motor housing **106**, when it is screwed down. The rotation shaft (i.e., the rib motor rotation shaft **202**) of each rib rotation motor **104** connects to a single rib spar **108** via a servo horn at the rib pivot point **304**. The rib spars **108** are aligned such that they all share the same rotation axis. All of the ribs (i.e., Rib 1, Rib 2, Rib 3, Rib 4, and Rib 5) are encased in the flexible fin casing **110**, which attaches to rib hook(s) **302** at the base of each of the rib spars **108** near the motor housing **106**. The exterior of the fin casing **110** (which is flexible) defines the surface of the fin casing **110** (see FIG. 4A and FIG. 4B), as the fin casing **110** conforms to the angle deflections of the plurality of ribs (i.e., Rib 1, Rib 2, Rib 3, Rib 4, and Rib 5) contained in the fin casing **110**.

[0031] Actuation of the fin rotation motor **102** drives rotation of fins (such as the actively controlled curvature robotic fin **100**) with control over fin stroke amplitude and fin stroke frequency. Actuation of each rib rotation motor **104** drives a rotation of a rib spar **108** about an axis parallel to a fin **100** rotation, of the actively controlled curvature robotic fin **100**. The independent actuation of multiple rib rotation motors **104** enables independent angular deflections of the rib spars **108**. The deflections of the ribs spars **108** deform the flexible fin casing **110** and serve to define the shape of the surface of the fin casing **110**. This controlled fin **100** surface shape is defined as the fin **100** curvature of the actively controlled curvature robotic fin **100**.

[0032] A combination of fin **100** rotation and rib rotation actuation (and thus fin **100** stroke amplitude, stroke frequency, and curvature control) provides control over the fin **100** shape over the course of a fin **100** stroke. This controllable shape-time history enables control over the magnitude and direction of fin **100** generated forces in a fluid or gas medium, such as water. Mounting one or multiple fins **100** on a vehicle in an underwater or water surface environment enables precise vectoring of propulsion and control forces for platform vehicle **780** maneuvering.

[0033] The actively controlled curvature robotic fin **100** has advantages over rotating propellers and passively deforming fins in force control, especially in dynamic, flow-changing environments (flow conditions data **711**). Controlling the fin **100** surface curvature during a fin **100** stroke allows controlled vectoring of fin **100** forces which provides an advantage in generating control forces (maneuvering vector force data **712**). Additionally, a controlled shape-changing fin **100** can take advantage of the changing flow fields to provide more reliable propulsion forces at slow speeds and in flow-changing environments (flow conditions data **711**). The actively controlled curvature robotic fin **100** may have an additional advantage over rotating propellers in dealing with debris such as near-shore vegetation, in that the actively controlled curvature robotic fin **100** may likely not get stuck or tangled in debris objects, as easily as conventional propulsion devices.

[0034] In a first exemplary embodiment, new features of the actively controlled curvature robotic fin **100** include the presence and use of actuated fin ribs within a fin **100**, individual rotational actuation of each fin rib (i.e., Rib 1, Rib 2, Rib 3, Rib 4, and Rib 5) enabling variable deflections between the ribs (i.e., Rib 1, Rib 2, Rib 3, Rib 4, and Rib 5), a flexible fin casing **110** provides the fin **100** surface to the fins whose

curvature is actively controlled by the motion of the fin ribs, and also, provides a compact and easy to assemble housing for the of rib actuators.

[0035] In a second exemplary embodiment, the ribs (i.e., Rib 1, Rib 2, Rib 3, Rib 4, and Rib 5) of the actively controlled curvature robotic fin **100** can be either rigid or compliant (flexible) structural members and can be actuated using direct angular rotation or through bending of the compliant structure. In addition to hooks, the method of attaching the fin casing **110** to the ribs (i.e., Rib 1, Rib 2, Rib 3, Rib 4, and Rib 5) can include but are not limited to: adhesives, hook-and-loop fasteners, and buttons.

[0036] Tests for force production measurements and kinematics measurement, (i.e., kinematics algorithms (A3) to include forward gait; reverse gait; upward gait; downward gait; and kinematics interpolate) are used to validate fin propulsion effectiveness. Algorithm unit **730** can contain control algorithms, and command algorithms, as well as kinematics algorithms such as in algorithms A1, A2, A3 through An, where A1 is a control algorithm, A2 is a command algorithm and A3 is a kinematics algorithm.

[0037] Referring to FIG. 7, proprietary control software and proprietary software drivers operating in conjunction with automated microcontrollers, computers and computer processors (such as computer processor **706**) associated with control electronics circuits in the actively controlled curvature robotic fin **100** cause the control electronics to actuate rib (i.e., Rib 1, Rib 2, Rib 3, Rib 4, and Rib 5) motions. The computers, computer processors (such as computer processor **706**) and associated control electronics can be either and/or resident in and/or on the actively controlled curvature robotic fin **100** and/or resident in a location remote from the actively controlled curvature robotic fin **100** and where the computers, computer processors (such as computer processor **706**), and associated control electronics can be either communicatively coupled to the actively controlled curvature robotic fin **100** over a communications network **772**, including hard wired or wireless communications networks including data communications facilities. The software includes algorithms (such as algorithms A1 through An) and other program code (such as program code **600**), and memory **708** associated with repository **710** contains data (represented by R90 through R94 and Rn) accessible to the program code **600** and/or algorithms.

[0038] Referring to FIG. 5, fin **100** force measurements were made by mounting an assembled actively controlled curvature robotic fin **100** to a rigid plate **506** attached to a force and torque transducer **502**. Force/Torque measurements data **714** were divided by the effective moment arm, the distance from the force/torque transducer **502** to the center of pressure on the actively controlled curvature robotic fin **100**. The time histories data of force measurements validated the thrust, lift and drag production of the actively controlled curvature robotic fin **100**, where the thrust and/or drag can be produced by either one or more of a fin **100** gait, i.e., fin **100** stroke amplitude or rib deflections within the fin causing **110** a rippling movement of the fin **100**, corresponding to motion vectors and/or stability vectors compensating for external vector forces, corresponding to a float and/or relative stationary position (hover).

[0039] Referring to FIG. 1, FIG. 6, FIG. 7, and FIG. 9 (where FIG. 9 illustrates an exemplary computer readable and computer executable medium **902** containing a computer program product **900** including method operations included in

program code **600** executed on a system **700**, implementing robotic fin **100** actuation in platform vehicle **780**.

[0040] The time history of fin **100** curvature, defined as the curvature profile over a single fin **100** flap, is defined by the time histories of the individual rib rotation angles within that actively controlled curvature robotic fin **100**. Combined with the time history of the fin **100** rotation angle, this defines the kinematics for the fin **100**. Smooth rib and fin **100** rotation time histories are achieved by commanding key servo rotation points for each individual rib and fin **100** servo throughout the fin **100** stroke, and then interpolating between these points to achieve the desired rotation angles throughout the stroke (in other words, interpolates between predefined angular positions to determine a position at an intermediate time). A snippet of a program code **600** including the functions for

defining actively controlled curvature robotic fin **100** kinematics is included below (this exemplary version of the program code **600** is not limited and exhaustive of the types of methods of actuation that can be implemented in program code. Various changes in form and details of the program code can be made without departing from the spirit and scope of the invention; thus, adaptations and modifications of the program code, as well as other aspects of the specific embodiments adopted by others by applying knowledge within the skill of the art, may be performed without departing from the general concept of the exemplary embodiments of the invention. Therefore, such adaptations and modifications are intended to be within the meaning and range of equivalents of the disclosed embodiments. In the program code **600**, for each gait definition, a unique row vector is defined for each servo, and each row vector defines that servo's positions over time:

```

Program Code 600:
//define forward gait
int8_t forward_gait[servos_per_fin][positions] = {
    {-100,-100,100,100,100,100,-100,-100},
    {-50,-50,50,50,50,50,-50,-50},
    {50,50,-50,-50,-50,-50,50,50},
    {100,100,-100,-100,-100,-100,100,100},
    {0,71,100,71,0,-71,-100,-71}};
//define reverse gait
int8_t reverse_gait[servos_per_fin][positions] = {
    {-50,-100,-50,0,50,100,50,0},
    {0,-50,-100,-50,0,50,100,50},
    {50,0,-50,-100,-50,0,50,100},
    {100,50,0,-50,-100,-50,0,50},
    {0,-71,-100,-71,0,71,100,71}};
//define lift/up gait
int8_t upward_gait[servos_per_fin][positions] = {
    {100,-28,-28,-28,-68,-68,-20,60},
    {-26,-10,-2,-2,-30,-30,-38,-54},
    {-54,10,2,2,30,30,14,-26},
    {36,16,12,8,48,48,52,76},
    {-60,-58,-49,-31,-2,35,72,94}};
//define lift/down gait
int8_t downward_gait[servos_per_fin][positions] = {
    {-100,28,28,28,68,68,20,-60},
    {26,10,2,2,30,30,38,54},
    {54,-10,-2,-2,-30,-30,-14,26},
    {-36,-16,-12,-8,-48,-48,-52,-76},
    {60,58,49,31,2,-35,-72,-94}};
//define demo gait
int8_t demo_gait[servos_per_fin][positions] = {
    {-100,-50,100,100,100,50,-100,-100},
    {-50,-50,50,50,50,50,-50,-50},
    {50,50,-50,-50,-50,-50,50,50},
    {100,100,-100,-100,-100,-100,100,100},
    {0,71,100,71,0,-71,-100,-71}};
//define home (centered) gait
int8_t home_gait[servos_per_fin][positions] = {
    {0,0,0,0,0,0,0,0},
    {0,0,0,0,0,0,0,0},
    {0,0,0,0,0,0,0,0},
    {0,0,0,0,0,0,0,0},
    {0,0,0,0,0,0,0,0}};
//decides which gait to run
int8_t kinematics_interpolate(uint8_t gait, float pcurrent, uint8_t pnext,
uint8_t i)
{
    int8_t val1;
    int8_t val2;
    if(gait==NONE)
        return 0;
    else if(gait==FORWARD)
        {
            val1=forward_gait[i][(uint8_t)pcurrent];
            val2=forward_gait[i][pnext];
        }
    else if(gait==REVERSE)

```

-continued

```

{
    val1=reverse_gait[i][(uint8_t)pcurrent];
    val2=reverse_gait[i][pnext];
}
else if(gait==LIFT)
{
    val1=upward_gait[i][(uint8_t)pcurrent];
    val2=upward_gait[i][pnext];
}
else if(gait==DOWN)
{
    val1=downward_gait[i][(uint8_t)pcurrent];
    val2=downward_gait[i][pnext];
}
else if(gait==DEMO)
{
    val1=demo_gait[i][(uint8_t)pcurrent];
    val2=demo_gait[i][pnext];
}
else if(gait==HOME)
{
    val1=home_gait[i][(uint8_t)pcurrent];
    val2=home_gait[i][pnext];
}
return interpolatef(fmod(pcurrent,1), 0, 1, val1, val2);
}
//calculates and interpolates kinematics
void kinematics_calculate(uint8_t fin_gait[ ], float pcurrent, uint8_t
pnext)
{
    for(int i=0; i<servos_per_fin; i++)//cycle through each servo
    {
        rib_position[FL][i] =
            (kinematics_interpolate(fin_gait[0],pcurrent,pnext,i)
            //make sure fits within servo movement
            if(amplification[FL] < 0)
                amplification[FL]=0;
            if(amplification[FL] > 1)
                amplification[FL]=1;
            //interpolate gait to match servo range, and factor in
amplification
            rib_position[FL][i] = interpolate((int8_t)rib_position[FL][i], -100, 100,...
            DRIVE_SPEED_MIN*amplification[FL],...
            DRIVE_SPEED_MAX*amplification[FL]);
        }
    }
//runs the kinematics based on a timer
void kinematics(void)
{
    //----- start TIME PASSED CALCULATOR
    //get time passed
    t_stroke_end = clockGetus( );
    t_stroke_time_passed = t_stroke_end - t_stroke_start;
    //if timer goes over allowed time in stroke, reset
    if(t_stroke_time_passed > time_per_stroke_us)
    {
        t_stroke_time_passed -= time_per_stroke_us;//determine
time that it went over
        t_stroke_start = clockGetus()-t_stroke_time_passed;//reset
timer
    }
    //----- end TIME PASSED CALCULATOR
    //----- start DETERMINE ARRAY POSITION
    //determine position in kinematics to use, given current time
passed
    float position_current = interpolatef(t_stroke_time_passed, 0,
time_per_stroke_us,...
    0, positions);
    //calculate the next position
    uint8_t position_next = position_current +1;
    if(position_next>(positions-1))
        position_next=0;
    //----- end DETERMINE ARRAY POSITION
    //----- start CALCULATE KINEMATICS
    kinematics_calculate(FL_gait,FL.position_current,position_next);
    //----- end CALCULATE KINEMATICS
}

```

-continued

```

//----- start MBAB
rib_position[FL][bulk]=interpolate(rib_position[FL][bulk],DRIVE_SPE
ED_MIN,...
DRIVE_SPEED_MAX,min_bulk_LF,max_bulk_LF);
//----- end MBAB
//----- start Sending final commands to servos
act_setSpeed(&rib1_FL,rib_position[FL][rib1]);
act_setSpeed(&rib2_FL,rib_position[FL][rib2]);
act_setSpeed(&rib4_FL,rib_position[FL][rib4]);
act_setSpeed(&rib5_FL,rib_position[FL][rib5]);
act_setSpeed(&bulk_FLf,rib_position[FL][bulk]);
act_setSpeed(&bulk_FLr,rib_position[FL][bulk]);
}
Where int = integer
Where val = value
Where FL = forward left
Where pcurrent = position_current
Where pnext = position_next
Where MBAB = mean bulk angle bias, and
Where a library of C-code functions called "WebbotLib is used
which defines various functions, such as "act_setSpeed",

```

[0041] Referring to FIG. 6, the process of defining the kinematics for each actively controlled curvature robotic fin **100** represented by the above program code **600** includes the following operations:

[0042] A first operation (operation 1) defines a fin **100** gait, or combination of fin **100** and rib angle-time histories, by determining fin **100** stroke angle(s) for rib 1, rib 2, rib 4, rib 5 and/or any number of ribs utilized.

[0043] A second operation (operation 2), or sub-operation, repeats the first operation above to define preprogrammed fin gaits which produce thrust in desired directions.

[0044] In a third operation (operation 3), logic gates are used to determine which fin gaits to combine (gait combination data **716**), based on desired fin thrust.

[0045] In a fourth operation (operation 4), weighted percentages (weighted percentages data **720**) are calculated for the determined and selected fin gaits which are to be combined, in order to produce the desired fin **100** thrust.

[0046] In a fifth operation (operation 5), fin angles and rib angles are combined for each operation in the preprogrammed stroke time histories (stroke time history data **718**) from the selected gaits determined in the above third operation (operation 3) and the weighted percentages (weighted percentages data **720**) calculated from the above fourth operation (operation 4); and

[0047] In a sixth operation (operation 6), based on fin **100** gait, computed from the above operation 5 and also in conjunction with defined stroke amplitude and frequency, commands are generated and sent to onboard fin **100** actuators and rib actuators.

[0048] The fin(s) **100** (i.e., the robotic fin(s) **100**) can be incorporated into unmanned underwater vehicle(s) **780** (UUV's), where the UUV is propelled by a plurality of fin(s) **100**; in a third exemplary embodiment, the UUV vehicle **780** can be propelled by at least four fin(s) **100**. In other embodiments, the vehicle **780** can be propelled by at least one fin **100**. UUV models are validated by comparing open-loop simulated responses (using computational fluid dynamics) with the experimentally measured responses to fin thrust and lift inputs. Closed-loop control algorithms (feedback control algorithms), which command changes in fin kinematics, are tested on the UUV and validate fin **100** and UUV models and

demonstrate precise maneuvering capabilities of the actively controlled curvature robotic pectoral fin **100**.

[0049] Vehicle **780** hardware control and computations are performed by a 16 MHz A T MEGA 2560 microcontroller.

[0050] Vehicle **780** can range in length from about 0.40 meters to about 2 meters having an ideal length of about 1.01 meters.

[0051] Referring to FIG. 7 and FIG. 8, where FIG. 8 shows coordinate reference frames of vehicle **780**. The vehicle **780** employs a water-tight cylinder for housing lithium batteries including lithium and other types of batteries (such as battery **782**); control electronics, sensors, and inertial measurement units (IMUs) including: a three-axis gyro, a three-axis accelerometer and compass.

[0052] Referring to FIG. 8, the fin **100** mounts and housings are designed to reduce drag by minimizing cross-flow through the vehicle hull. The flooded, fiberglass molded nose, middle, and tail sections are currently reserved for additional payloads and sensors **784**. Optimization of the performance of vehicle **780** allows minimization of (i.e., reduced) power requirements.

[0053] The rigid body hull of vehicle **780** is modeled separately from the elastic bending and twisting of the fin(s) **100**. The rigid body hull of vehicle **780** is based on six degree-of-freedom (6-DOF) translational and rotational equations. The vehicle **780** hull is symmetric about the x-z and y-z planes, and although it is not symmetric about the x-y plane; according to W. Wang et al. "Modeling and simulation of the VideoRay ProIII underwater vehicle," MTS OCEANS Conference, May 2007, it is assumed to be symmetric because it operates at low-speeds. Thus, because of vehicle **780** symmetry and low speed operation, lift forces on the body become negligible.

[0054] The rigid body mass terms of the vehicle **780** were calculated from CAD models and physical measurements of the vehicle **780**. Drag terms were computed in computational fluid dynamics simulations and showed that the linear terms were negligible along and about all axes.

[0055] Referring to FIG. 8, the actively controlled curvature fin(s) **100** are mounted to the rigid body of the vehicle **780**, such that fin **100** thrust acts along the body x-axis and fin **100** lift acts along the body z-axis. Fin **100** force generation along the body y-axis is negligible, because the differential in

the force produced by the left side fin(s) **100** with the right side fin(s) **100** is close to zero in this direction.

[0056] Fin **100** thrust is characterized as (fT); and fin **100** lift is characterized as (fL). LF, LB, RF and RB identify the left front, left back, right front, and right back of fin(s) **100**, respectively. The x-position of the center of pressure on the fin(s) **100** is denoted by XF for the front fin(s) **100** and XB for the back fin(s) **100**. The y-position of the center of pressure on the fin(s) **100** is denoted by YL for the left fin(s) **100** and YR for the right fin(s) **100**. The center of pressure defines the location of the fin **100** generated forces which is needed to compute the fin **100** generated moments, and was determined in computational fluid dynamics (CFD) simulations.

[0057] CFD computed thrust time history for fin **100** forward gait kinematics using experimental forward gait kinematics at 1.8 Hz flapping frequency derived an average thrust of 1.76 Newtons, achieved an improved force generation, even when considering that vehicle **780** fin **100** thrust decreases linearly with free stream flow speed in the regime of flow speeds the vehicle experiences. Fin **100** kinematics selection and fin **100** force production characterization is an active area of research, and the fin **100** model continues to be updated as these fin **100** studies produce results. More detailed studies of fin **100** kinematics including curvature time histories, and flapping frequency and amplitude will lead to improved fin **100** thrust and lift performances, which in turn will lead to improved vehicle **780** performance, as well as a more refined fin **100** model.

[0058] Heave Performance: experimental results demonstrate a steady-state vehicle **780** heave rate of 3.3 cm/s.

[0059] Yaw Performance: An expected magnitude of average thrust from each of the four fin(s) **100** is 0.7 Newtons. Experimental results demonstrate a steady-state yaw rate of 41 degrees/second.

[0060] While validation of the 6-degrees of freedom vehicle **780** dynamics model is not complete using only analysis of experimental heave and yaw data, it does validate the methods by which vehicle **780** dynamics coefficients are calculated. The rigid body mass, added mass, and drag coefficients validated through heave and yaw experiments are computed using equations and tools as the coefficients describing other vehicle **780** modes of motion.

[0061] Closed loop maneuvering performance: Closed loop control performance for simple maneuvers is analyzed in simulation and experiments. Vehicle **780** control is achieved by combining preprogrammed fin **100** gaits to alter the fin **100** kinematics and vector thrust in a direction to produce desired vehicle **780** motion.

[0062] Depth control: Feedback of vehicle **780** depth through a pressure transducer (SSI TECHNOLOGIES P51) provides the primary source of state information for vehicle **780** depth control. Fin **100** bias is controlled as a function of depth, pitch rate and angle, and roll rate and angle. As the vehicle **780** has sufficient natural damping in heave, feedback of depth rate is not needed. A gain constant is denoted by value K for a given subscripted state variable. In a dive maneuver, pitch and roll stability are ensured while depth is controlled to a commanded value. Simulated performance of the vehicle **780** is a simple depth change maneuver (moving vertically through a column of water) and is compared with experimental results. In simulated and experimental depth maneuvers, the vehicle **780** completes a 40 cm dive in 14 seconds. The simulated depth matches the experimental depth with an average error of 0.7 cm during the dive maneu-

ver. However, during resurfacing (after 14 seconds), the simulation and the experiment diverge, leading to a depth error of 15 cm, after 16 seconds of the dive maneuver. Explanation for this error includes changes in vehicle **780** buoyancy, attributed to pockets of air within the wetted hull, and shifting of mass within the vehicle **780** electronics housing leading to fin **100** bias angle saturation to maintain pitch and roll stability, as associated with mean bulk angle bias (MBAB).

[0063] Heading control: Feedback of vehicle **780** heading through a magnetic compass and yaw rate through a gyro provide the primary sources of state information for vehicle **780** heading control. According to P. Sitorus et al., "Design and implementation of paired pectoral fins locomotion of labriform fish applied to a fish robot," Journal of Bionic Engineering, vol. 6, pp. 37-45, 2009, fin **100** curvature is controlled as a function of forward speed, and yaw rate and angle. While vehicle **780** position in the x-y plane would normally also drive fin **100** curvature, the vehicle **780** currently does not have an accurate positioning system in this plane. Simulated performance of the vehicle **780** in a simple yaw maneuver (in hover) is in agreement with experimental results. An 180 degree turn is completed in 6 seconds in both simulation and experiment. During the entire 180 degree heading change and steady-state oscillation, the average error between simulation and experiment is 16 degrees. (An explanation for this error includes interference in compass heading measurements due to magnetic field disturbances in the laboratory environment). Improved performance has been achieved in the heading control algorithm, based on validation of the feedback controller for heading, such as adding yaw rate feedback, which dampens oscillations in heading control response.

[0064] Vehicle **780** operates at a forward speed surge rate from about zero (0) meters per second (m/s) and/or zero (0) knots up to a maximum of about 1.2 m/s and/or 2.3 knots. Operating in a range between 2 and 3 knots enables much greater position holding capability and vehicle **780** control in shallow water areas.

[0065] Vehicle **780** maximum heave rate ranges from about 3.1 cm/s up to about 3.8 cm/s.

[0066] Vehicle **780** maximum yaw rate ranges from about 37 degrees/second up to about 41 degrees/s.

[0067] Proportional-integral-derivative (PID) control of fin **100** parameters is sufficient for quick and accurate simple propulsion and/or control maneuvers achieving a highly maneuverable UUV vehicle **780**. Even though fin(s) **100** have demonstrated the capability to vector thrust in multiple directions through changes to curvature and stroke bias angle, values for these fin **100** parameters, such as fin **100** kinematics of gait optimization for maximum thrust and lift are being improved so as to achieve greater control authority and improved vehicle **780** performance.

[0068] Referring to FIG. 6, FIG. 7 and FIG. 9, a computer readable medium **902** having a plurality of computer executable instructions executed by a computer processor **706**, executing program code **600**, causes the computer processor **706** to perform a plurality of method operations of actuating robotic fin **100** maneuvers in association with platform vehicle **780**, the computer executable instructions include: instructions performing a defining operation 1, where operation 1 defines a fin **100** gait and a combination of fin **100** and rib angle-time histories of a fin **100** stroke angle for at least rib 1, rib 2, rib 3, rib 4 and rib 5.

[0069] Again referring to, FIG. 6, FIG. 7 and FIG. 9, a plurality of method operations of actuating robotic fin 100 maneuvers in association with platform vehicle 780, further includes instructions performing a decision operation 2, selected from a group of decision operations consisting of deciding to repeat the defining operation 1 of defining pre-programmed fin 100 gait thrust directions or deciding to continue to a determining operation 3.

[0070] Again referring to, FIG. 6, FIG. 7 and FIG. 9, a plurality of method operations of actuating robotic fin 100 maneuvers in association with platform vehicle 780, further includes instructions performing the determining operation 3, using logic gates to determine which fin 100 gaits to combine based on desired fin 100 thrust.

[0071] Further referring to, FIG. 6, FIG. 7 and FIG. 9, a plurality of method operations of actuating robotic fin 100 maneuvers in association with platform vehicle 780, further includes instructions performing a calculating operation 4, calculating weighted percent of selected fin 100 gaits needed to produce desired fin 100 thrusts, selected in operation 3.

[0072] Again referring to Further, FIG. 6, FIG. 7 and FIG. 9, a plurality of method operations of actuating robotic fin 100 maneuvers in association with platform vehicle 780, further includes a combining operation 5, combining fin 100 and rib angles for each fin 100 gait thrust direction preprogrammed stroke time histories defined from selected gaits in the determining operation 3 and weights in the calculating operation 4.

[0073] Further referring to FIG. 6, FIG. 7 and FIG. 9, a plurality of method operations of actuating robotic fin 100 maneuvers in association with platform vehicle 780, further includes instructions sending commands, using computed fin 100 gaits selected from the combining operation 5 with user defined stroke amplitude and frequency, commanding fin 100 and rib control electronics to actuate actively controlled curvature of ribs, causing actively controlled robotic propulsion and steering maneuverability of onboard robotic fin 100, causing platform vehicle 780 to maneuver in a fluid medium.

[0074] While the exemplary embodiments have been particularly shown and described with reference to preferred embodiments thereof, it will be understood, by those skilled in the art that the preferred embodiments including the first exemplary embodiment, and the second exemplary embodiment have been presented by way of example only, and not limitation; furthermore, various changes in form and details can be made therein without departing from the spirit and scope of the invention. Thus, the breadth and scope of the present exemplary embodiments should not be limited by any of the above described preferred exemplary embodiments, but should be defined only in accordance with the following claim and/or claims and their equivalents. Any and/or all references cited herein are each entirely incorporated by reference herein, including all data, tables, figures, and text presented in the cited references. Also, it is to be understood that the phraseology or terminology herein is for the purpose of description and not of limitation, such that the terminology or phraseology of the present specification is to be interpreted by the skilled artisan in light of the teachings and guidance presented herein, in combination with the knowledge of one of ordinary skill in the art. The foregoing description of the specific embodiments will so fully reveal the general nature of the invention that others can, by applying knowledge within the skill of the art, readily modify and/or adapt for various applications such specific embodiments, without undue experimentation, and without departing from the gen-

eral concept of the exemplary embodiments. Therefore, such adaptations and modifications are intended to be within the meaning and range of equivalents of the disclosed embodiments, based on the teaching and guidance presented herein.

What is claimed is:

1. An actively controlled curvature robotic propulsion and steering apparatus, the apparatus comprising:

- a fin rotation motor having a fin rotation shaft;
- a motor housing;
- a plurality of rib rotation motors, having a plurality of rib rotation motor shafts, residing in the motor housing;
- a plurality of ribs, mechanically movable and communicatively coupled to the plurality of rib rotation motors, wherein the plurality of ribs includes a plurality of rib spars connected between the plurality of ribs and the plurality of rib rotation motors, rotationally coupled to and actuated by the plurality of rib rotation motor shafts;
- a fin casing, within which the plurality of ribs reside, forming the actively controlled curvature robotic propulsion and steering apparatus, wherein the actively controlled curvature robotic propulsion and steering apparatus is a mechanical fin;
- a plurality of control electronics circuits communicatively connected to fin rotation motor and the plurality of rib rotation motors; and
- a computer processor, communicatively coupled to the plurality of control electronics, wherein the computer processor having actuation code, when executed by the computer processor, causes automated simultaneous actuation propulsion and steering maneuverability of the actively controlled curvature robotic mechanical fin.

2. The mechanical fin according to claim 1, wherein the computer processor and the plurality of control electronics circuits are communicatively connected by a communication protocol to the mechanical fin, wherein the computer processor and the plurality of control electronics circuits are selected from a group of computer processors and control electronics circuits consisting of the computer processor and the plurality of control electronics circuits residing in the mechanical fin and residing external to the mechanical fin, wherein the communication protocol is selected from a group of communication protocols consisting of a direct network connection and a remote network connection, and wherein the plurality of control electronics circuits includes at least an input device and at least an output device.

3. The mechanical fin according to claim 1, wherein the mechanical fin, when actuated, generates a plurality of gait propulsion forces and a plurality of directional steering forces in media selected from a group of media including liquid and gaseous media, corresponding to a plurality of fin stroke amplitudes, a plurality of fin stroke frequencies and a plurality of fin rib deflections creating a plurality of velocity vectors including lift and thrust directional steering maneuverability vectors within the group of media.

4. The mechanical fin according to claim 3, wherein, the plurality of fin rib deflections and the plurality of gait propulsion forces and the plurality of directional steering forces and the plurality of fin stroke amplitudes and the plurality of fin stroke frequencies causes the mechanical fin to actively change curvature and perform a continuous flapping motion simultaneously to operate in changing flow conditions, and low speed maneuvering conditions, wherein the group of

media includes liquids, such as water, oil, and a colloidal mixture of elements (including icy waters), and gases, including air.

5. A robotic system having a plurality of one or more mechanical fins maneuvering the robotic system in a fluid medium, the robotic system comprising:

a vehicle platform having a rigid body hull, wherein the vehicle platform includes a nose section, a middle section and a tail section;

a plurality of batteries, a plurality of control electronics and sensors, including inertial sensors, residing in the rigid body hull and the molded nose and the tail sections, wherein the plurality of batteries provide power to the control electronics, sensors and a plurality of motors contained within the vehicle platform;

an at least one mechanical fin, of the plurality of one or more mechanical fins, is maneuverably connected to the vehicle platform, wherein the plurality of one or more mechanical fins comprise:

a fin rotation motor having a fin rotation shaft, a motor housing,

a plurality of rib rotation motors, having a plurality of rib rotation motor shafts, residing in the motor housing,

a plurality of ribs, mechanically moveably and communicatively coupled to the plurality of rib rotation motors, wherein the plurality of ribs includes a plurality of rib spars connected between the plurality of ribs and the plurality of rib rotation motors, rotationally coupled to and actuated by the plurality of rib rotation motor shafts,

a fin casing, within which the plurality of ribs resides, wherein the fin casing, having the plurality of ribs is the propulsion and steering element of the mechanical fin, and

a computer processor containing an actuation program code, that when executed by the computer processor causes the mechanical fin to actuate and generate a plurality of gait thrust and lift forces and a plurality of directional steering forces translating into a plurality of fin stroke amplitudes, a plurality of fin stroke frequencies and a plurality of fin rib deflections creating a plurality of velocity vectors including drag and thrust directional steering maneuverability vectors acting on the vehicle platform causing propulsion, steering and hovering maneuverability of the vehicle platform within the fluid medium, by causing the mechanical fin to actively change curvature and perform a continuous flapping motion simultaneously to operate in changing flow conditions and low speed operation in the fluid medium.

6. The system according to claim 5, wherein the computer processor and the plurality of control electronics circuits are communicatively connected by a communication protocol to the mechanical fin, wherein the computer processor and the plurality of control electronics circuits are selected from a group of computer processors and control electronics circuits consisting of the computer processor and the plurality of control electronics circuits residing in the mechanical fin and residing external to the mechanical fin and residing external to the vehicle platform, wherein the communication protocol is selected from a group of communication protocols consisting of a direct network connection and a remote network connection, and wherein the plurality of control electronics circuits include at least an input device and at least an output device.

7. The system according to claim 5, wherein the actuation program code, when executed by the computer processor, causes the computer processor to perform the following operations, causing the mechanical fins to provide propulsion, steering and hovering maneuverability of the vehicle platform:

```
//define forward gait
int8_t forward_gait[servos_per_fin][positions] = {
    {-100,-100,100,100,100,100,-100,-100},
    {-50,-50,50,50,50,50,-50,-50},
    {50,50,-50,-50,-50,-50,50,50},
    {100,100,-100,-100,-100,-100,100,100},
    {0,71,100,71,0,-71,-100,-71}};

//define reverse gait
int8_t reverse_gait[servos_per_fin][positions] = {
    {-50,-100,-50,0,50,100,50,0},
    {0,-50,-100,-50,0,50,100,50},
    {50,0,-50,-100,-50,0,50,100},
    {100,50,0,-50,-100,-50,0,50},
    {0,-71,-100,-71,0,71,100,71}};

//define lift/up gait
int8_t upward_gait[servos_per_fin][positions] = {
    {100,-28,-28,-28,-68,-68,-20,60},
    {-26,-10,-2,-2,-30,-30,-38,-54},
    {-54,10,2,2,30,30,14,-26},
    {36,16,12,8,48,48,52,76},
    {-60,-58,-49,-31,-2,35,72,94}};

//define lift/down gait
int8_t downward_gait[servos_per_fin][positions] = {
    {-100,28,28,28,68,68,20,-60},
    {26,10,2,2,30,30,38,54},
    {54,-10,-2,-2,-30,-30,-14,26},
    {-36,-16,-12,-8,-48,-48,-52,-76},
    {60,58,49,31,2,-35,-72,-94}};

//define demo gait
int8_t demo_gait[servos_per_fin][positions] = {
    {-100,-50,100,100,100,50,-100,-100},
    {-50,-50,50,50,50,50,-50,-50},
    {50,50,-50,-50,-50,-50,50,50},
```

-continued

```

{100,100,-100,-100,-100,-100,100,100},
{0,71,100,71,0,-71,-100,-71}};
//define home (centered) gait
uint8_t home_gait[servos_per_fin][positions] = {
  {0,0,0,0,0,0,0,0},
  {0,0,0,0,0,0,0,0},
  {0,0,0,0,0,0,0,0},
  {0,0,0,0,0,0,0,0},
  {0,0,0,0,0,0,0,0}};
//decides which gait to run
uint8_t kinematics_interpolate(uint8_t gait, float pcurrent, uint8_t pnext,
uint8_t i)
{
  int8_t val1;
  int8_t val2;
  if(gait==NONE)
    return 0;
  else if(gait==FORWARD)
  {
    val1=forward_gait[i][(uint8_t)pcurrent];
    val2=forward_gait[i][pnext];
  }
  else if(gait==REVERSE)
  {
    val1=reverse_gait[i][(uint8_t)pcurrent];
    val2=reverse_gait[i][pnext];
  }
  else if(gait==LIFT)
  {
    val1=upward_gait[i][(uint8_t)pcurrent];
    val2=upward_gait[i][pnext];
  }
  else if(gait==DOWN)
  {
    val1=downward_gait[i][(uint8_t)pcurrent];
    val2=downward_gait[i][pnext];
  }
  else if(gait==DEMO)
  {
    val1=demo_gait[i][(uint8_t)pcurrent];
    val2=demo_gait[i][pnext];
  }
  else if(gait==HOME)
  {
    val1=home_gait[i][(uint8_t)pcurrent];
    val2=home_gait[i][pnext];
  }
  return interpolatef(fmod(pcurrent,1), 0, 1, val1, val2);
}
//calculates and interpolates kinematics
void kinematics_calculate(uint8_t fin_gait[], float pcurrent, uint8_t pnext)
{
  for(int i=0; i<servos_per_fin; i++)//cycle through each servo
  {
    rib_position[FL][i] =
      (kinematics_interpolate(fin_gait[0],pcurrent,pnext,i)
      //make sure fits within servo movement
      if(amplification[FL] < 0)
        amplification[FL]=0;
        if(amplification[FL] > 1)
          amplification[FL]=1;
      //interpolate gait to match servo range, and factor in amplification
      rib_position[FL][i] = interpolate((int8_t)rib_position[FL][i], -100, 100,...
      DRIVE_SPEED_MIN*amplification[FL],...
      DRIVE_SPEED_MAX*amplification[FL]);
  }
}
//runs the kinematics based on a timer
void kinematics(void)
{
  //----- start TIME PASSED CALCULATOR
  //get time passed
  t_stroke_end = clockGetus();
  t_stroke_time_passed = t_stroke_end - t_stroke_start;
  //if timer goes over allowed time in stroke, reset
  if(t_stroke_time_passed > time_per_stroke_us)

```

-continued

```

    {
        t_stroke_time_passed -= time_per_stroke_us;//determine time that it
went over
        t_stroke_start = clockGetus()-t_stroke_time_passed;//reset timer
    }
//----- end TIME PASSED CALCULATOR
//----- start DETERMINE ARRAY POSITION
//determine position in kinematics to use, given current time passed
float position_current = interpolate(t_stroke_time_passed, 0,
time_per_stroke_us,...
    0, positions);
//calculate the next position
uint8_t position_next = position_current +1;
if(position_next>(positions-1))
    position_next=0;
//----- end DETERMINE ARRAY POSITION
//----- start CALCULATE KINEMATICS
    kinematics_calculate(FL_gait,FL_position_current,position_next);
//----- end CALCULATE KINEMATICS
//----- start MBAB
rib_position[FL][bulk]=interpolate(rib_position[FL][bulk],DRIVE_SPEED_MIN,...
DRIVE_SPEED_MAX,min_bulk_LF,max_bulk_LF);
//----- end MBAB
//----- start Sending final commands to servos
act_setSpeed(&rib1_FL,rib_position[FL][rib1]);
act_setSpeed(&rib2_FL,rib_position[FL][rib2]);
act_setSpeed(&rib4_FL,rib_position[FL][rib4]);
act_setSpeed(&rib5_FL,rib_position[FL][rib5]);
act_setSpeed(&bulk_FLf,rib_position[FL][bulk]);
act_setSpeed(&bulk_FLr,rib_position[FL][bulk]);
};

```

Where int=integer

Where vat=value

Where FL=forward left

Where pcurrent=position_current

Where pnext=position_next

Where MBAB=mean bulk angle bias.

8. A computer readable medium having a plurality of computer executable instructions executed by a computer processor causing the computer processor to perform a plurality of method operations of actuating robotic fin maneuvers in association with a platform vehicle, the computer executable instructions comprising:

instructions performing a defining operation, defining a fin gait and a combination of fin and rib angle-time histories of a fin stroke angle of at least rib 1, rib 2, rib 3, rib 4 and rib 5;

instructions performing a decision operation, selected from a group of decision operations consisting of deciding to repeat the defining operation of defining preprogrammed fin gait thrust directions and deciding to continue to a determining operation;

instructions performing the determining operation, using logic gates to determine which fin gaits to combine based on desired fin thrust;

instructions performing a calculating operation, calculating weighted percent of fin gaits to combine, based on desired fin thrust determined in the determining operation;

instructions performing a combining operation, combining fin and rib angles for each fin gait thrust direction preprogrammed stroke time histories defined from selected gaits in the determining operation and weights in the calculating operation; and

instructions sending commands, using computed fin gaits selected from the combining operation with user defined

stroke amplitude and frequency, commanding fin and rib control electronics to actuate actively controlled curvature of ribs, causing actively controlled robotic propulsion and steering maneuverability of an at least one or more onboard robotic fin, causing actively controlled robotic propulsion and steering of the platform vehicle to maneuver in a fluid medium.

9. The computer readable medium, according to claim 8, wherein the defining operation instructions include the following actuation code instructions of defining forward gait:

```

//define forward gait
int8_t forward_gait[servos_per_fin][positions] = {
    {-100,-100,100,100,100,100,-100,-100},
    {-50,-50,50,50,50,50,-50,-50},
    {50,50,-50,-50,-50,-50,50,50},
    {100,100,-100,-100,-100,-100,100,100},
    {0,71,100,71,0,-71,-100,-71}};
//define reverse gait
int8_t reverse_gait[servos_per_fin][positions] = {
    {-50,-100,-50,0,50,100,50,0},
    {0,-50,-100,-50,0,50,100,50},
    {50,0,-50,-100,-50,0,50,100},
    {100,50,0,-50,-100,-50,0,50},
    {0,-71,-100,-71,0,71,100,71}};
//define lift/up gait
int8_t upward_gait[servos_per_fin][positions] = {
    {100,-28,-28,-28,-68,-68,-20,60},
    {-26,-10,-2,-2,-30,-30,-38,-54},
    {-54,10,2,2,30,30,14,-26},
    {36,16,12,8,48,48,52,76},
    {-60,-58,-49,-31,-2,35,72,94}};
//define lift/down gait
int8_t downward_gait[servos_per_fin][positions] = {
    {-100,28,28,28,68,68,20,-60},
    {26,10,2,2,30,30,38,54},
    {54,-10,-2,-2,-30,-30,-14,26},
    {-36,-16,-12,-8,-48,-48,-52,-76},
    {60,58,49,31,2,-35,-72,-94}};

```

-continued

```

//define demo gait
int8_t demo_gait[servos_per_fin][positions] = {
  {-100,-50,100,100,100,50,-100,-100},
  {-50,-50,50,50,50,50,-50,-50},
  {50,50,-50,-50,-50,-50,50,50},
  {100,100,-100,-100,-100,-100,100,100},
  {0,71,100,71,0,-71,-100,-71}};
//define home (centered) gait
int8_t home_gait[servos_per_fin][positions] = {
  {0,0,0,0,0,0,0,0},
  {0,0,0,0,0,0,0,0},
  {0,0,0,0,0,0,0,0},
  {0,0,0,0,0,0,0,0},
  {0,0,0,0,0,0,0,0}}.

```

10. The computer readable medium, according to claim 8, wherein the decision operation instructions include the following actuation code instructions of interpolating between predefined angular positions to determine a position at an intermediate time:

```

//decides which gait to run
int8_t kinematics_interpolate(uint8_t gait, float pcurrent, uint8_t pnext,
uint8_t i)
{
  int8_t val1;
  int8_t val2;
  if(gait==NONE)
    return 0;
  else if(gait==FORWARD)
  {
    val1 =forward_gait[i][(uint8_t)pcurrent];
    val2=forward_gait[i][pnext];
  }
  else if(gait==REVERSE)
  {
    val1 =reverse_gait[i][(uint8_t)pcurrent];
    val2=reverse_gait[i][pnext];
  }
  else if(gait==LIFT)
  {
    val1=upward_gait[i][(uint8_t)pcurrent];
    val2=upward_gait[i][pnext];
  }
  else if(gait==DOWN)
  {
    val1=downward_gait[i][(uint8_t)pcurrent];
    val2=downward_gait[i][pnext];
  }
  else if(gait==DEMO)
  {
    val1=demo_gait[i][(uint8_t)pcurrent];

```

-continued

```

    val2=demo_gait[i][pnext];
  }
  else if(gait==HOME)
  {
    val1=home_gait[i][(uint8_t)pcurrent];
    val2=home_gait[i][pnext];
  }
  return interpolatef(fmod(pcurrent,1), 0, 1, val1, val2);
};

```

Where int=integer
 Where val=value
 Where pcurrent=position_current
 Where pnext=position_next.

11. The computer readable medium, according to claim 8, wherein the calculating operation instructions are characterized as the following actuation code instructions of calculating and interpolating kinematics:

```

//calculates and interpolates kinematics
void kinematics_calculate(uint8_t fin_gait[], float pcurrent, uint8_t
pnext)
{
  for(int i=0; i<servos_per_fin; i++)//cycle through each servo
  {
    rib_position[FL][i] =
      (kinematics_interpolate(fin_gait[0],pcurrent,pnext,i)
      //make sure fits within servo movement
      if(amplification[FL] < 0)
        amplification[FL]=0;
      if(amplification[FL] > 1)
        amplification[FL]=1;
      //interpolate gait to match servo range, and factor in
      amplification
      rib_position[FL][i] = interpolate((int8_t)rib_position[FL][i], -100,
      100,...
      DRIVE_SPEED_MIN*amplification[FL],...
      DRIVE_SPEED_MAX*amplification[FL]);
  }
};

```

Where int=integer
 Where val=value
 Where pcurrent=position_current
 Where pnext=position_next
 Where FL=forward left.

12. The computer readable medium, according to claim 8, wherein the combining operation instructions are characterized in the following actuation code instructions of running kinematics routines:

```

//runs the kinematics based on a timer
void kinematics(void)
{
  //----- start TIME PASSED CALCULATOR
  //get time passed
  t_stroke_end = clockGetus( );
  t_stroke_time_passed = t_stroke_end - t_stroke_start;
  //if timer goes over allowed time in stroke, reset
  if(t_stroke_time_passed > time_per_stroke_us)
  {
    t_stroke_time_passed -= time_per_stroke_us;//determine time that it
went over
    t_stroke_start = clockGetus( )-t_stroke_time_passed;//reset timer
  }
  //----- end TIME PASSED CALCULATOR
  //----- start DETERMINE ARRAY POSITION
  //determine position in kinematics to use, given current time passed

```

-continued

```

float position_current = interpolatef(t_stroke_time_passed, 0,
time_per_stroke_us,...
    0, positions);
//calculate the next position
uint8_t position_next = position_current +1;
if(position_next>(positions-1))
    position_next=0;
//----- end DETERMINE ARRAY POSITION
//----- start CALCULATE KINEMATICS
    kinematics_calculate(FL_gait,FL,position_current,position_next);
//----- end CALCULATE KINEMATICS
//----- start MBAB
rib_position[FL][bulk]=interpolate(rib_position[FL][bulk],DRIVE_SPEED_MIN,...
DRIVE_SPEED_MAX,min_bulk_LF,max_bulk_LF);
//----- end MBAB;

```

Where FL=forward left, and

Where MBAB=mean bulk angle bias.

13. The computer readable medium, according to claim **8**, wherein the sending commands operation instructions are characterized in the following actuation code:

```

//----- start Sending final commands to servos
act_setSpeed(&rib1_FL,rib_position[FL][rib1]);
act_setSpeed(&rib2_FL,rib_position[FL][rib2]);

```

-continued

```

act_setSpeed(&rib4_FL,rib_position[FL][rib4]);
act_setSpeed(&rib5_FL,rib_position[FL][rib5]);
act_setSpeed(&bulk_FL,rib_position[FL][bulk]);
act_setSpeed(&bulk_FLr,rib_position[FL][bulk]);
};

```

Where FL=forward left.

* * * * *