



(19) **United States**

(12) **Patent Application Publication**
ASAI et al.

(10) **Pub. No.: US 2018/0076792 A1**

(43) **Pub. Date: Mar. 15, 2018**

(54) **QUARTZ CRYSTAL BLANK AND QUARTZ CRYSTAL RESONATOR UNIT**

Publication Classification

(71) Applicant: **Murata Manufacturing Co., Ltd.**,
Nagaokakyo-shi (JP)

(51) **Int. Cl.**
H03H 9/10 (2006.01)
H03H 9/19 (2006.01)
H03H 9/02 (2006.01)

(72) Inventors: **MASARU ASAI**, Nagaokakyo-shi (JP);
Hiroaki Kaida, Nagaokakyo-shi (JP)

(52) **U.S. Cl.**
CPC *H03H 9/1021* (2013.01); *H03H 9/02015*
(2013.01); *H03H 9/19* (2013.01)

(21) Appl. No.: **15/815,942**

(57) **ABSTRACT**

(22) Filed: **Nov. 17, 2017**

A rectangular quartz crystal blank having long sides substantially parallel to a Z' axis of the quartz crystal blank, and short sides substantially parallel to an X axis of the quartz crystal blank. The quartz crystal blank includes a first center region, a second region and a third region that are adjacent to the first region along a long-side direction, and a fourth region and a fifth region that are adjacent to the first region along a short-side direction. A thickness of the second region and a thickness of the third region are smaller than a thickness of the first region, and/or a thickness of the fourth region and a thickness of the fifth region are smaller than the thickness of the first region, and $13.92 \leq W/T \leq 14.44$, where W is a length of a short side and T is a thickness.

Related U.S. Application Data

(63) Continuation of application No. PCT/JP2016/067439, filed on Jun. 10, 2016.

Foreign Application Priority Data

Jun. 12, 2015 (JP) 2015-118890

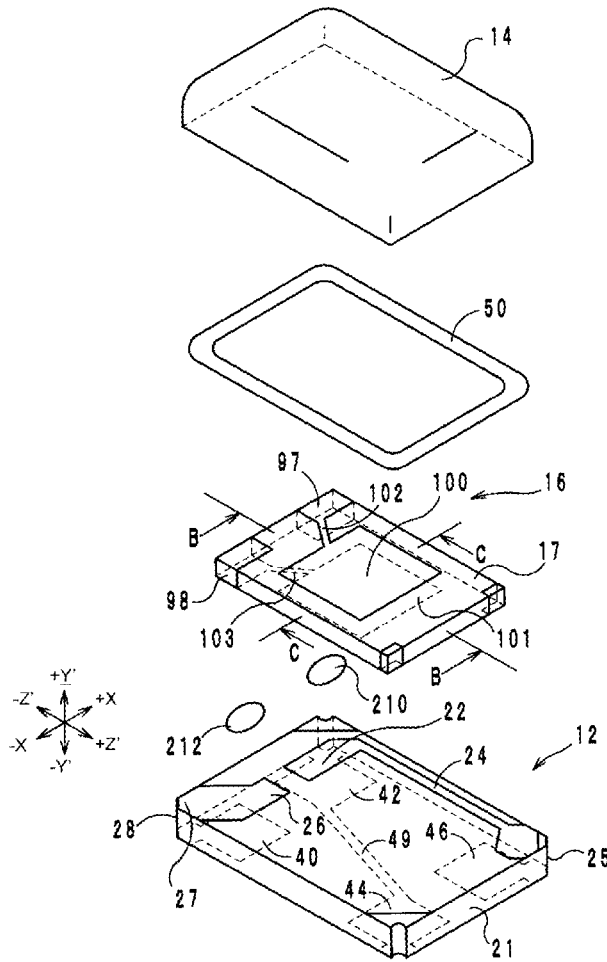

FIG. 1

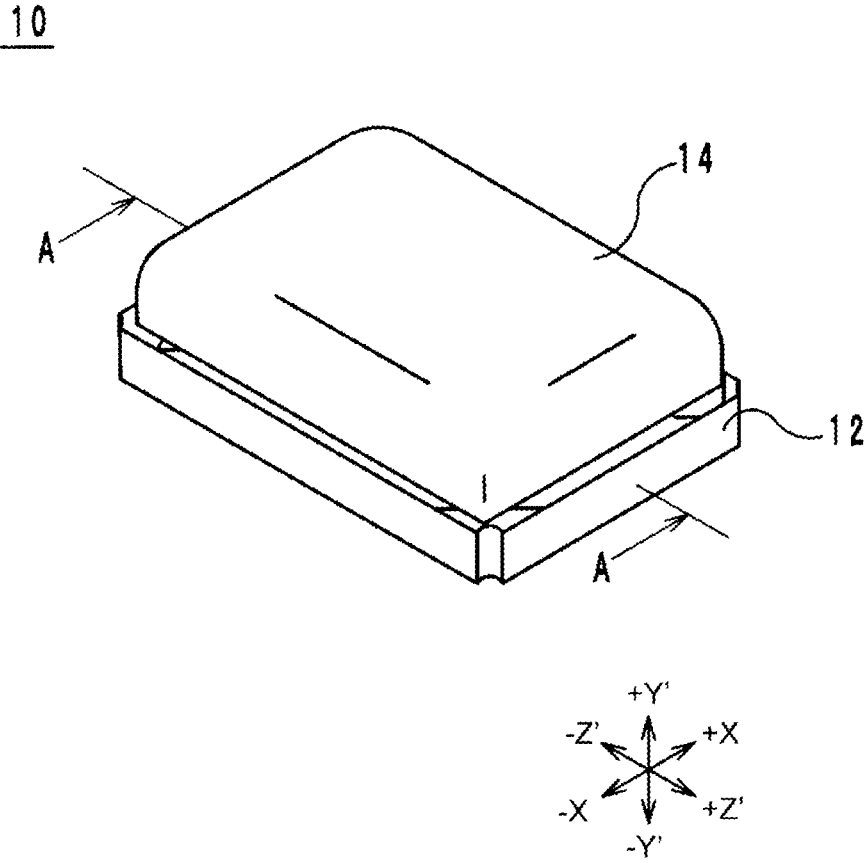

FIG. 2

10

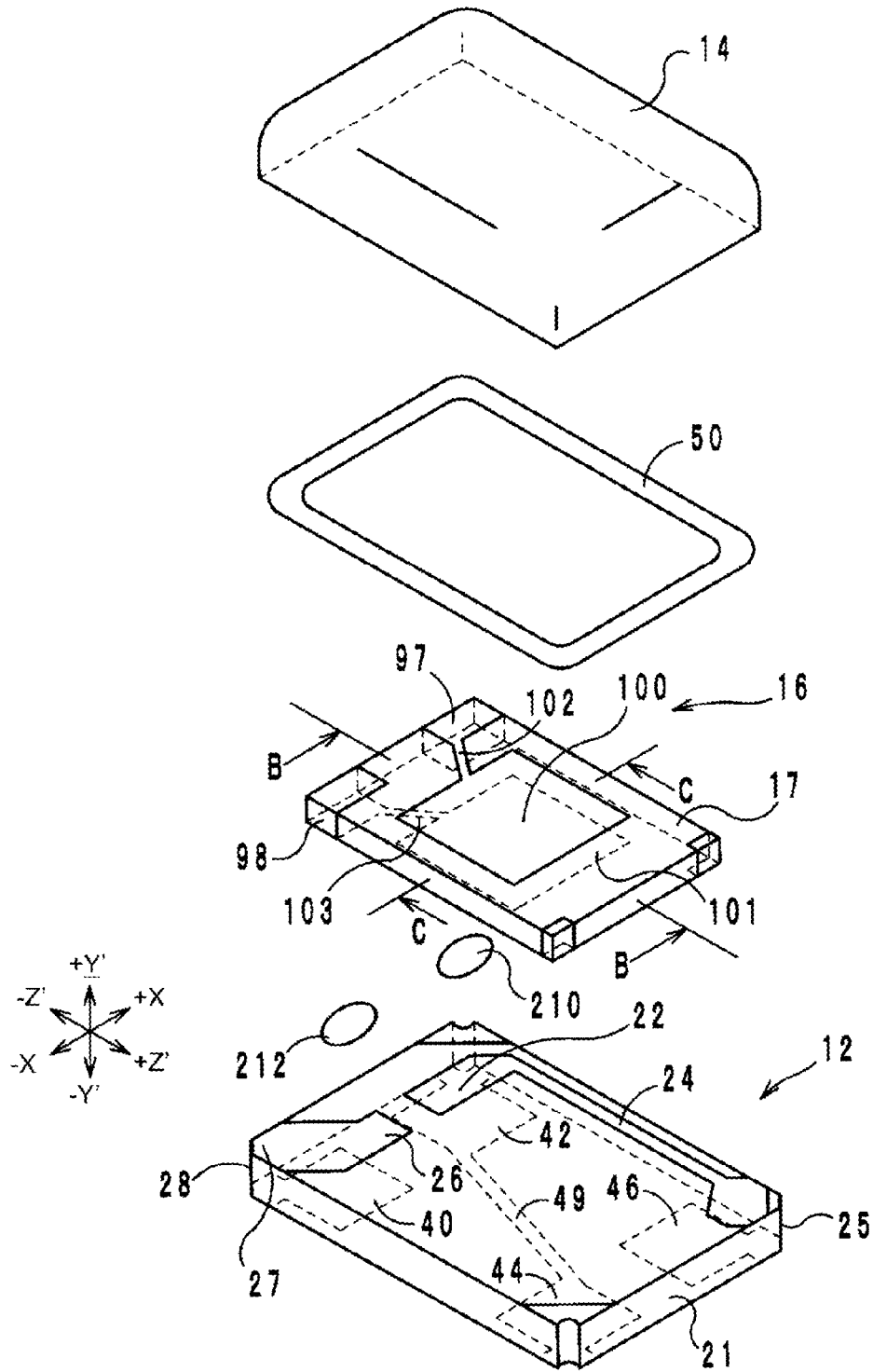

FIG. 3

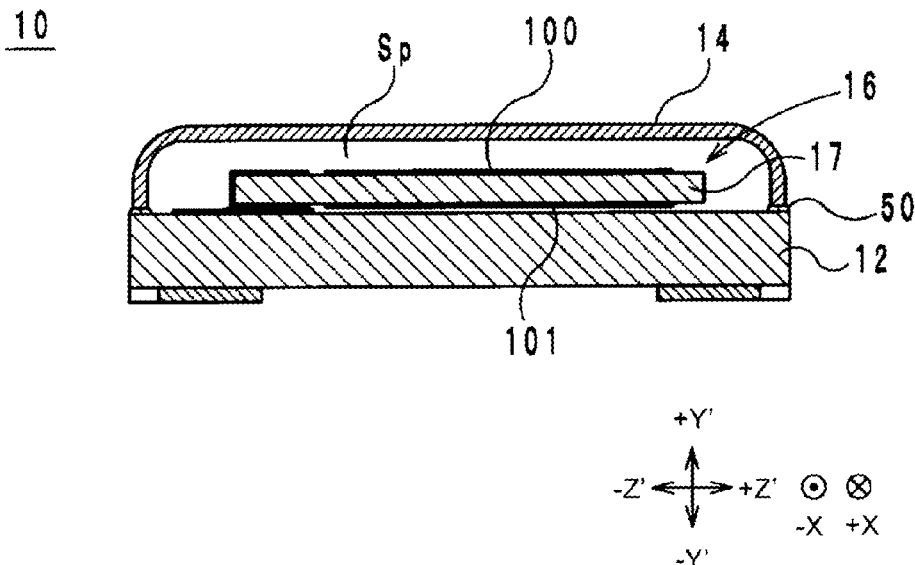

FIG. 4

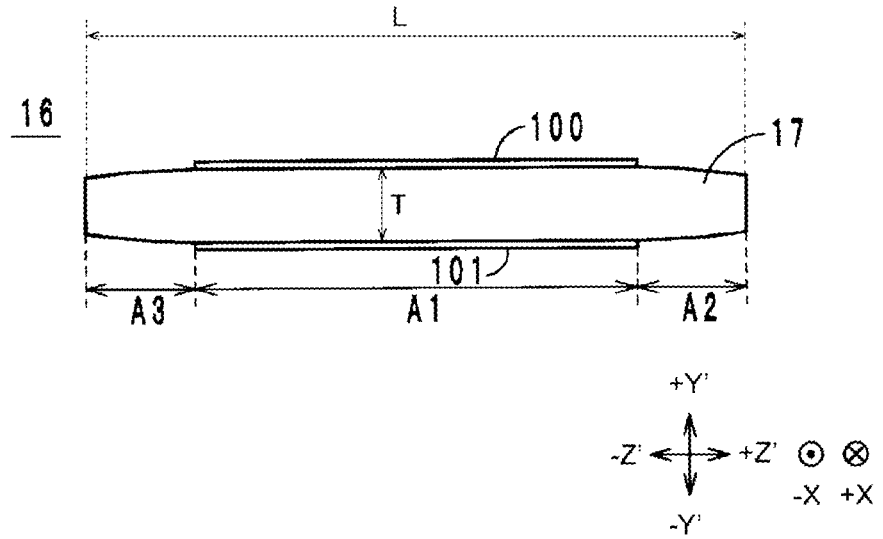

FIG. 5

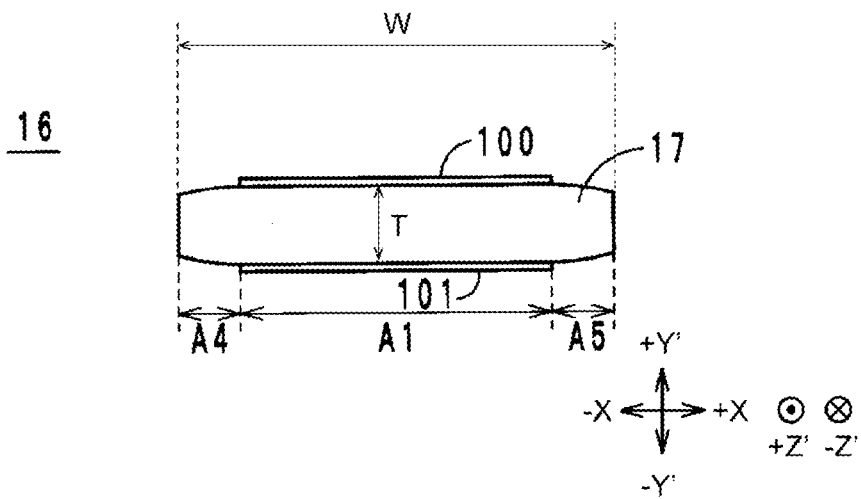

FIG. 6

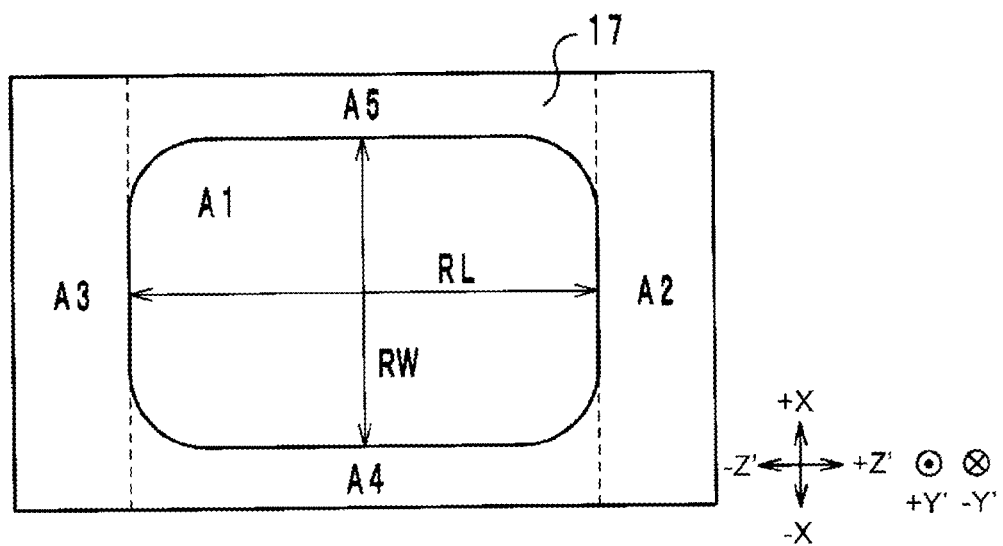

FIG. 7

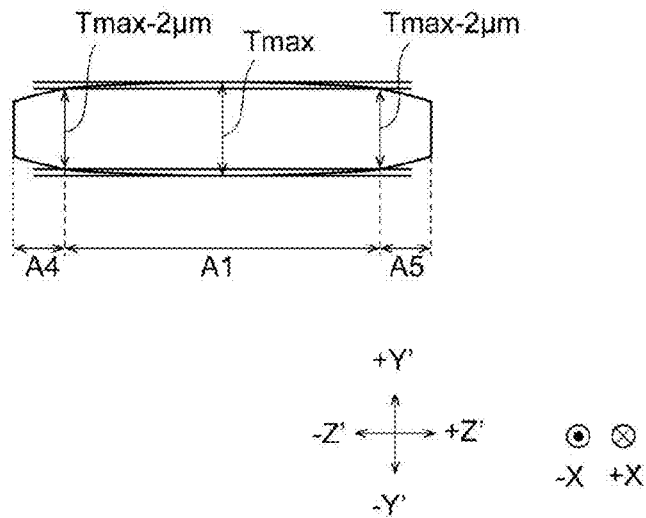

FIG. 8

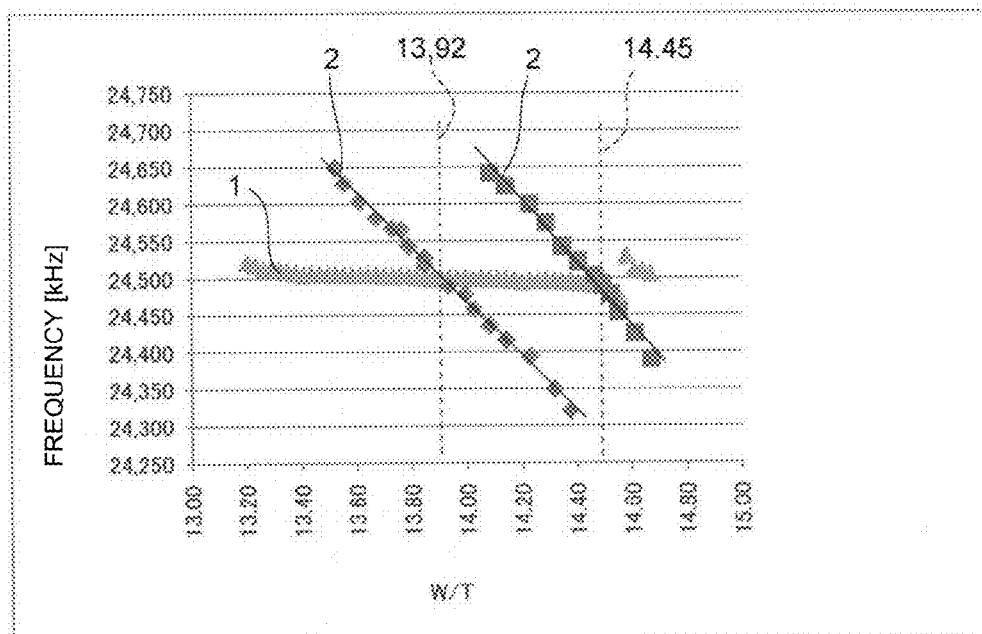

FIG. 9

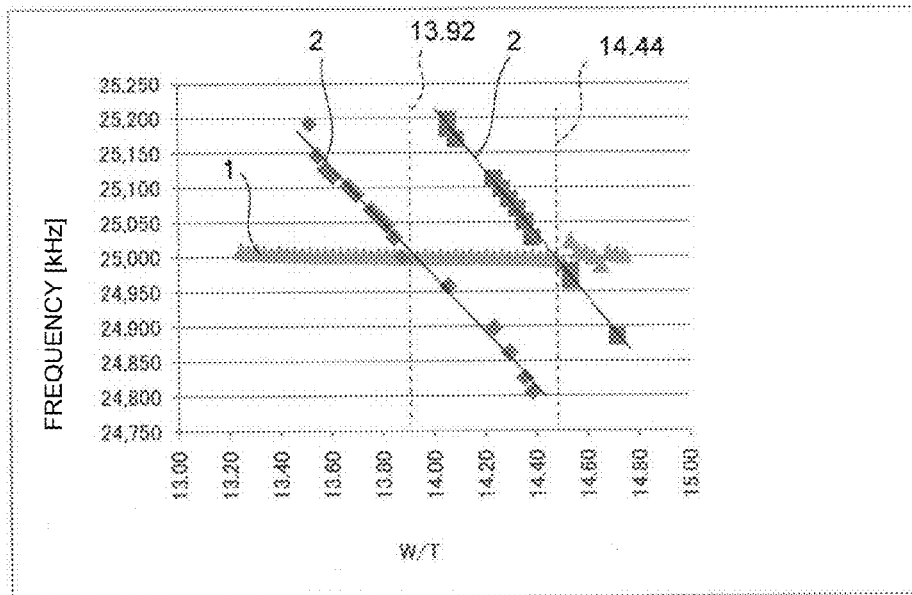

FIG. 10

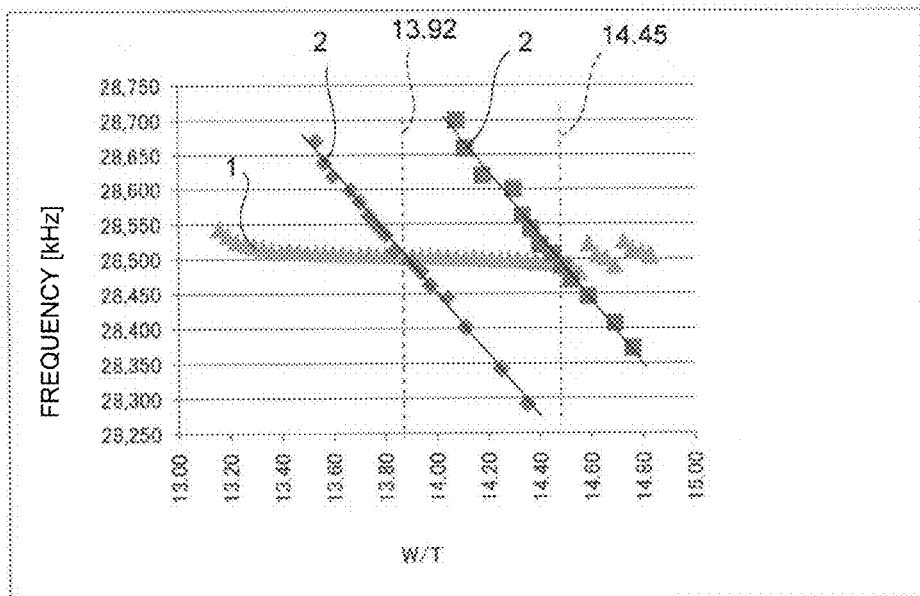

FIG. 11

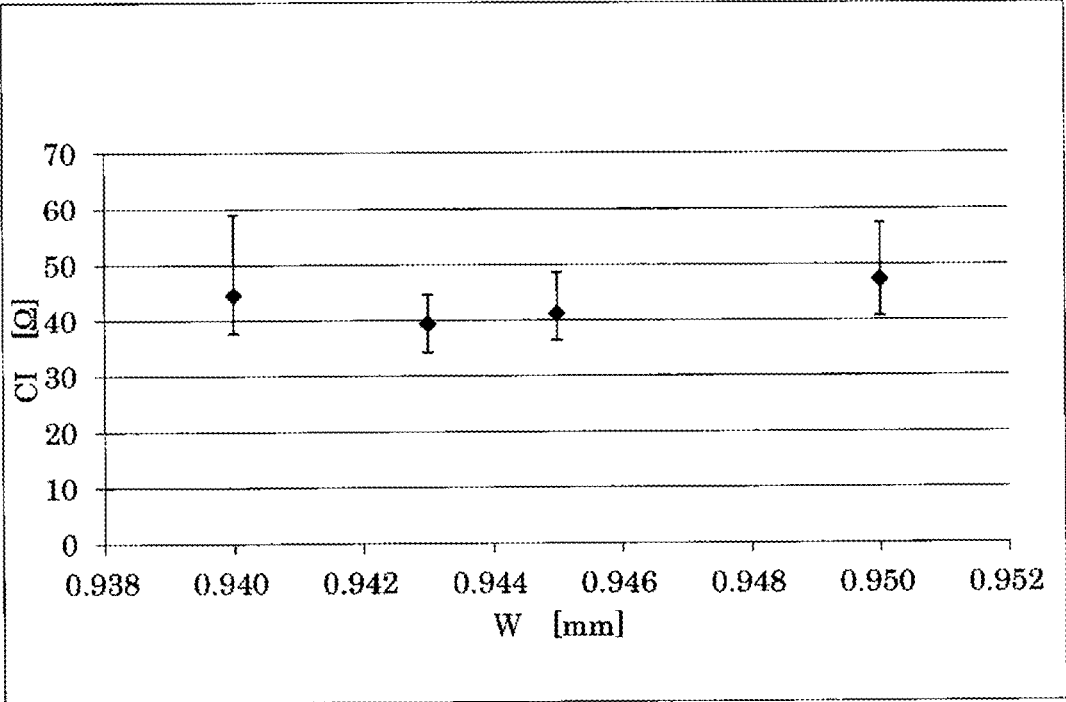

FIG. 12

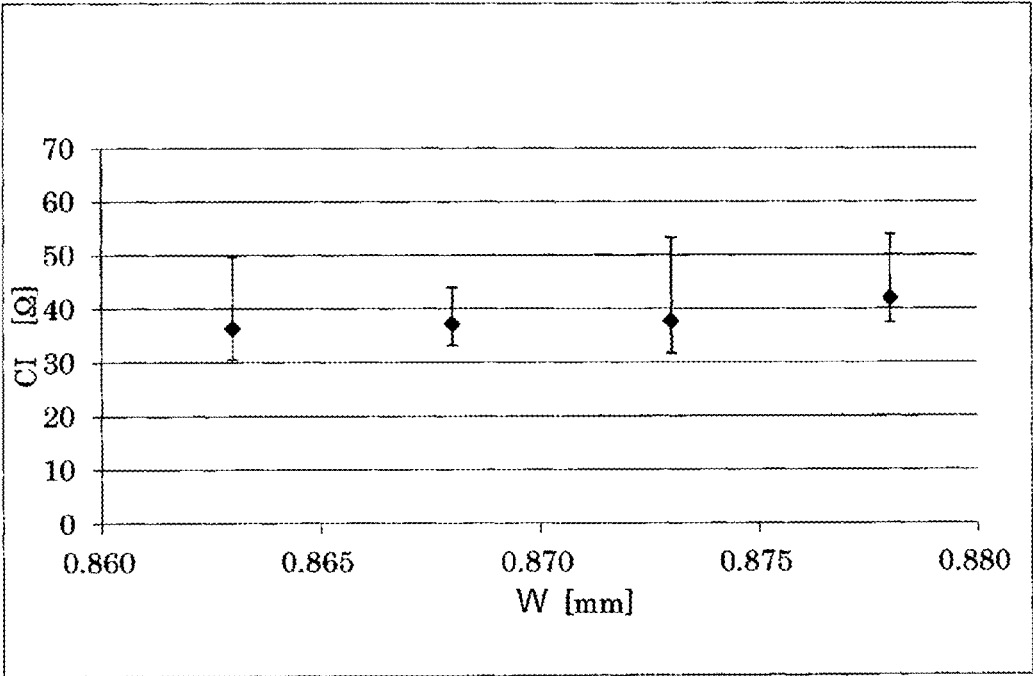

FIG. 13

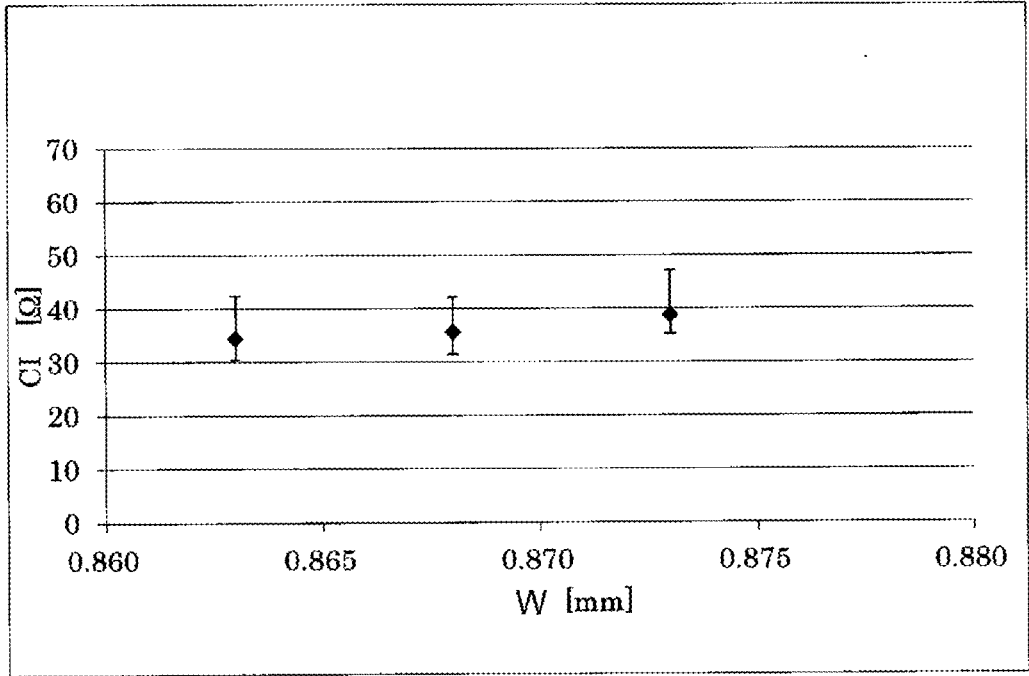

FIG. 14

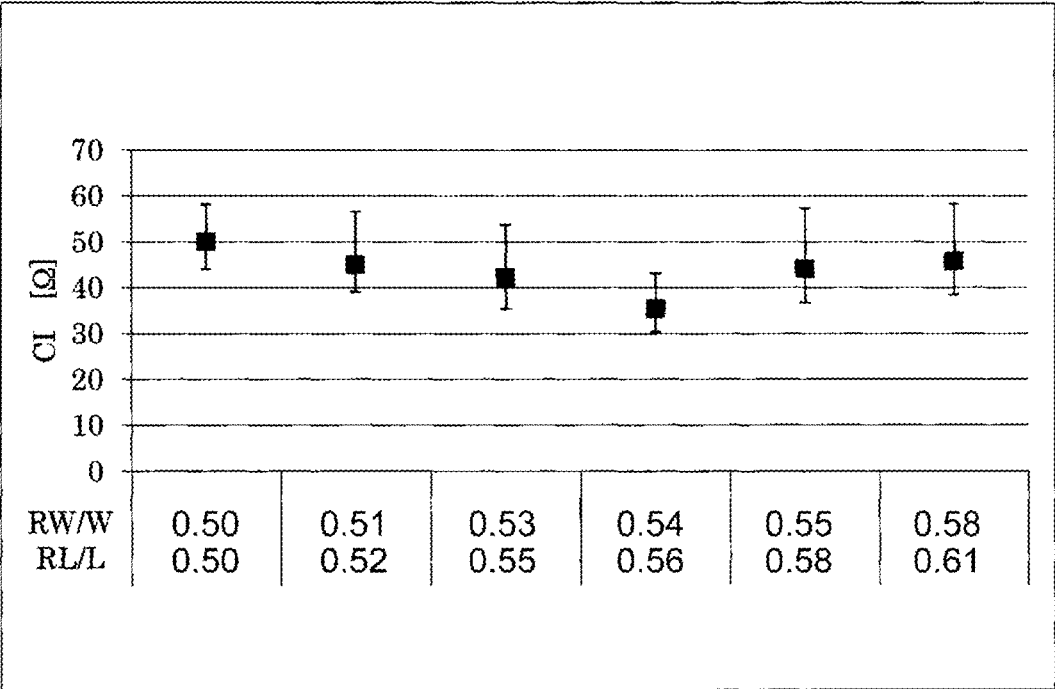

FIG. 15

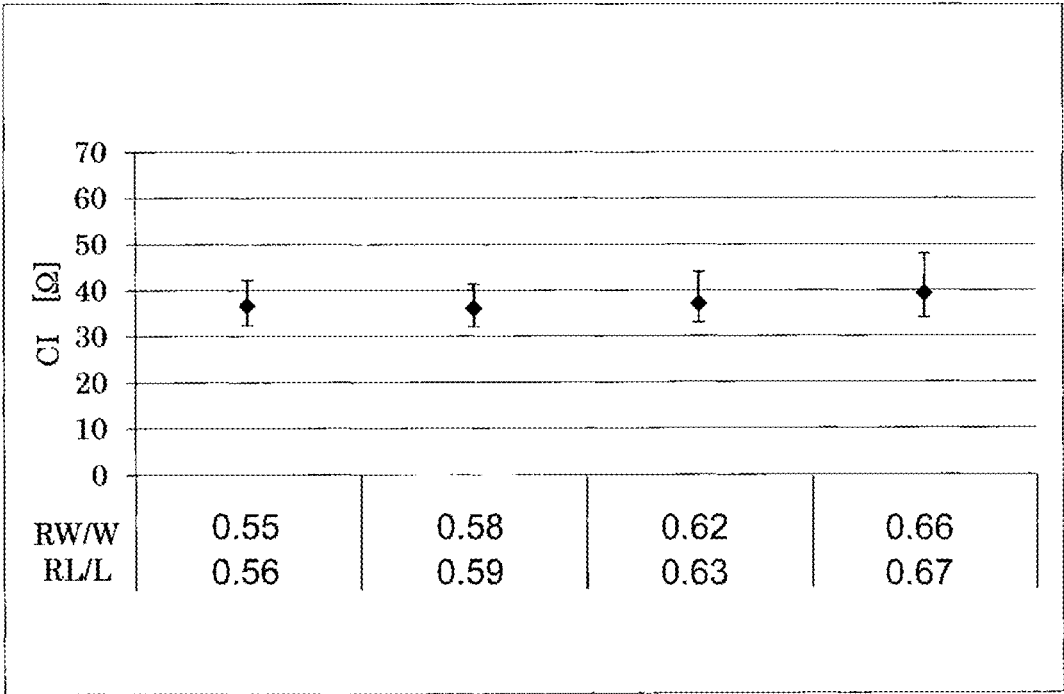

FIG. 16

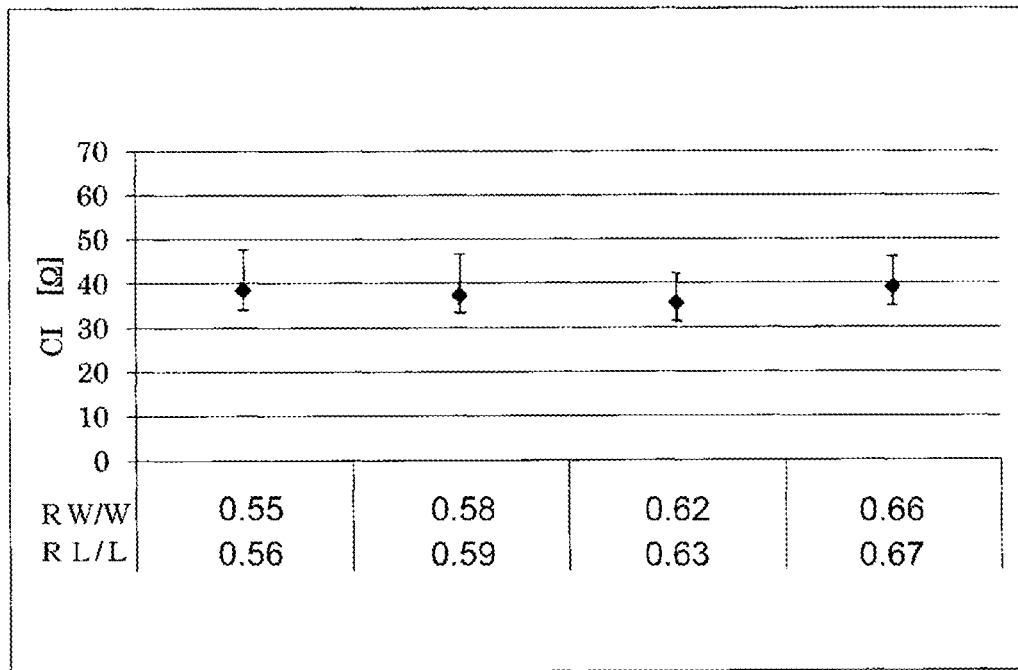

FIG. 17

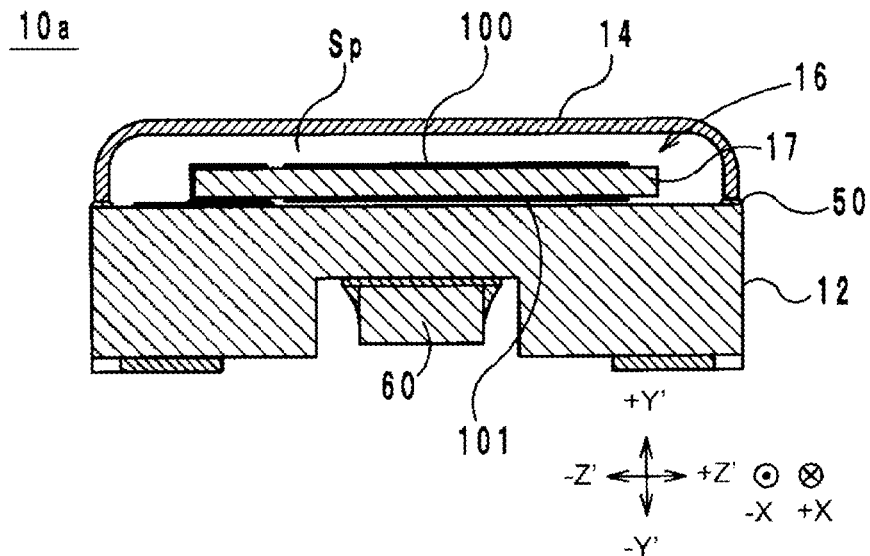

FIG. 18

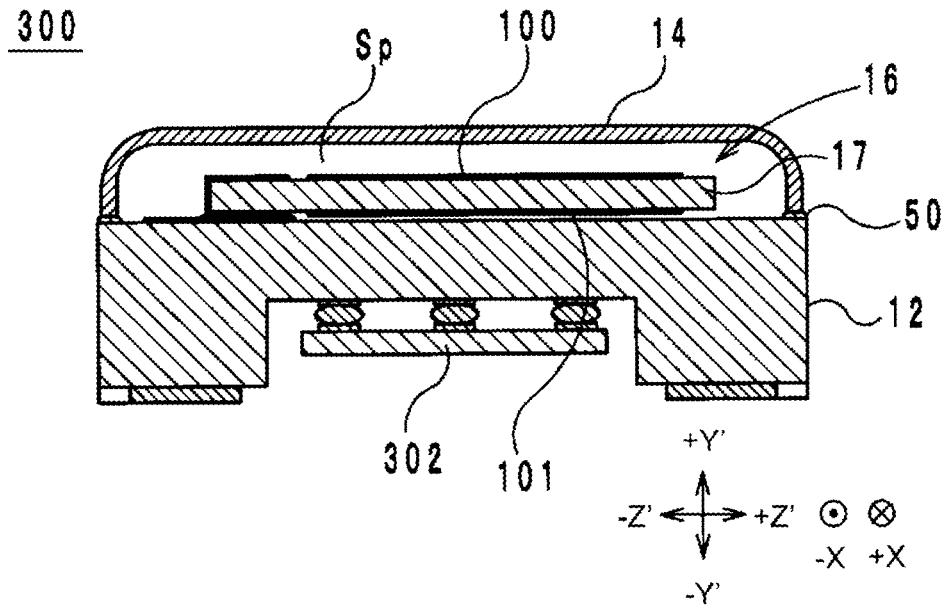

FIG. 19

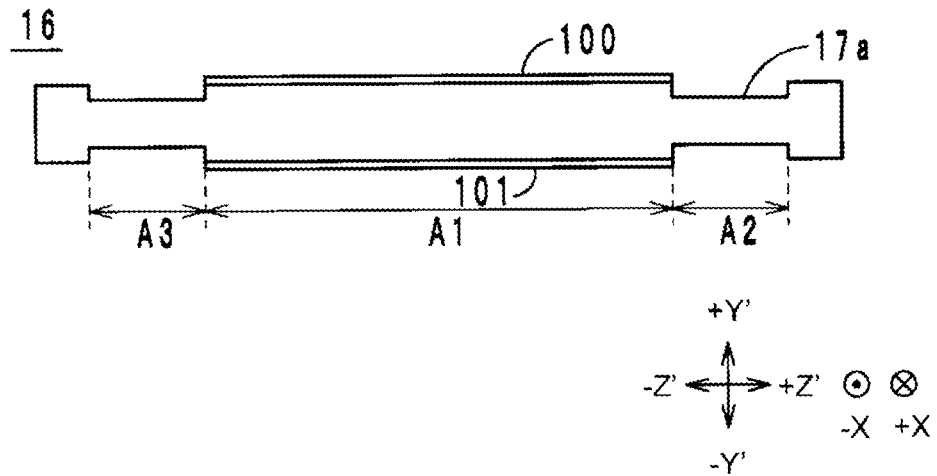
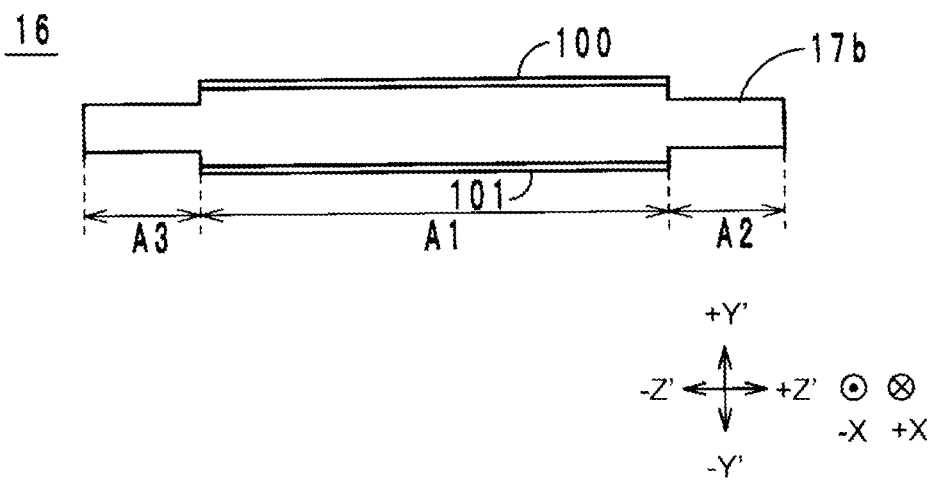

FIG. 20



QUARTZ CRYSTAL BLANK AND QUARTZ CRYSTAL RESONATOR UNIT

CROSS REFERENCE TO RELATED APPLICATIONS

[0001] The present application is a continuation of International application No. PCT/JP2016/067439, filed Jun. 10, 2016, which claims priority to Japanese Patent Application No. 2015-118890, filed Jun. 12, 2015, the entire contents of each of which are incorporated herein by reference.

FIELD OF THE INVENTION

[0002] The present invention relates to an AT-cut quartz crystal blank and a quartz crystal resonator unit.

BACKGROUND OF THE INVENTION

[0003] As reduction in size of a quartz crystal resonator unit has been demanded in recent years, it is necessary to reduce the size of a quartz crystal blank. However, when the size of a quartz crystal blank is reduced, the influence of a sub-vibration becomes pronounced or an influence of vibration leakage arises, and therefore series resistance tends to increase. Examples of existing inventions related to a quartz crystal blank and aimed at reduction of series resistance include a quartz crystal resonator plate described in Patent Document 1. End portions of the quartz crystal resonator plate are chamfered (beveled). Thus, vibration energy is confined under excitation electrodes, and appropriate series resistance can be achieved.

[0004] As described above, regarding a quartz crystal blank, various improvements have been made in order to achieve appropriate series resistance.

[0005] Patent Document 1: Japanese Unexamined Patent Application Publication No. 2013-34176

SUMMARY OF THE INVENTION

[0006] An object of the present invention is to provide a quartz crystal blank and a quartz crystal resonator unit that can reduce a crystal impedance (CI) value.

[0007] A quartz crystal blank according to an aspect of the present invention is an AT-cut quartz crystal blank that is plate-shaped and is rectangular when seen in a direction normal to a main surface. Long sides of the main surface are substantially parallel to a Z' axis of the quartz crystal blank. Short sides of the main surface are substantially parallel to an X axis of the quartz crystal blank. A frequency of a main vibration of the quartz crystal blank is in a range of 24.5 MHz to 28.5 MHz. The quartz crystal blank includes a first region including a center of the main surface when seen in the direction normal to the main surface, a second region and a third region that are adjacent to the first region on both sides in a long-side direction in which the long sides extend, and a fourth region and a fifth region that are adjacent to the first region on both sides in a short-side direction in which the short sides extend. A thickness of the first region is substantially uniform. A thickness of the second region and a thickness of the third region are smaller than the thickness of the first region, and/or a thickness of the fourth region and a thickness of the fifth region are smaller than the thickness of the first region. $13.92 \leq W/T \leq 14.44$ is satisfied, where W is a length of the first region, the fourth region, and the fifth region in the short-side direction, and T is the thickness of the first region.

[0008] The present invention is also directed at a quartz crystal resonator unit including the quartz crystal blank.

[0009] With the present invention, the CI value can be reduced.

BRIEF DESCRIPTION OF THE DRAWINGS

[0010] FIG. 1 is an external perspective view of a quartz crystal resonator unit 10.

[0011] FIG. 2 is an exploded perspective view of the quartz crystal resonator unit 10.

[0012] FIG. 3 is a sectional view taken along line A-A of FIG. 1.

[0013] FIG. 4 is a sectional view taken along line B-B of FIG. 2.

[0014] FIG. 5 is a sectional view taken along line C-C of FIG. 2.

[0015] FIG. 6 is a top view of a quartz crystal blank 17.

[0016] FIG. 7 is an enlarged view of a region A1.

[0017] FIG. 8 is a graph representing the relationship between the frequencies of a main vibration and sub-vibrations and W/T of a quartz crystal blank 17 in which the frequency of the main vibration is 24.5 MHz.

[0018] FIG. 9 is a graph representing the relationship between the frequencies of a main vibration and sub-vibrations and W/T of a quartz crystal blank 17 in which the frequency of the main vibration is 25.0 MHz.

[0019] FIG. 10 is a graph representing the relationship between the frequencies of a main vibration and sub-vibrations and W/T of a quartz crystal blank 17 in which the frequency of the main vibration is 28.5 MHz.

[0020] FIG. 11 is graph representing the result of an experiment performed on first to fourth samples.

[0021] FIG. 12 is graph representing the result of an experiment performed on fifth to eighth samples.

[0022] FIG. 13 is graph representing the result of an experiment performed on ninth to eleventh samples.

[0023] FIG. 14 is graph representing the result of an experiment performed on twelfth to seventeenth samples.

[0024] FIG. 15 is graph representing the result of an experiment performed on eighteenth to twenty-first samples.

[0025] FIG. 16 is graph representing the result of an experiment performed on twenty-second to twenty-fifth samples.

[0026] FIG. 17 is a sectional view of a quartz crystal resonator unit 10a according to a modification.

[0027] FIG. 18 is a sectional view of a quartz crystal oscillator 300.

[0028] FIG. 19 is a sectional view of a quartz crystal blank 17a according to another embodiment.

[0029] FIG. 20 is a sectional view of a quartz crystal blank 17b according to another embodiment.

DETAILED DESCRIPTION OF THE PREFERRED EMBODIMENTS

[0030] (Structure of Quartz Crystal Resonator Unit)

[0031] Hereinafter, a quartz crystal resonator unit that includes a quartz crystal blank according to an embodiment of the present invention will be described with reference to the drawings. FIG. 1 is an external perspective view of a quartz crystal resonator unit 10. FIG. 2 is an exploded perspective view of the quartz crystal resonator unit 10. FIG. 3 is a sectional view taken along line A-A of FIG. 1.

[0032] Hereinafter, a direction normal to the main surface of the quartz crystal resonator unit 10 is defined as the vertical direction, a direction in which the long sides of the quartz crystal resonator unit 10 extend when seen from above is defined as the long-side direction, and a direction in which the short sides of the quartz crystal resonator unit 10 extend is defined as the short-side direction. Hereinafter, structures may be described with respect to the axial directions of AT cut of a quartz crystal blank 17.

[0033] As illustrated in FIGS. 1 to 3, the quartz crystal resonator unit 10 includes a substrate body 12, a metal cap 14, a quartz crystal resonator 16, and an adhesive 50. The width of the short sides of the quartz crystal resonator unit 10 is 1.6 mm, and the length of the long sides of the quartz crystal resonator unit 10 is 2.0 mm.

[0034] The substrate 12 (an example of a circuit substrate) includes a substrate body 21; outer electrodes 22, 26, 40, 42, 44, and 46; wiring lines 24, 27, and 49; and via conductors 25 and 28.

[0035] The substrate body 21 is plate-shaped and is rectangular when seen from above. The substrate body 21 is made from, for example, a ceramic insulating material, such as an aluminum oxide sintered compact, a mullite sintered compact, an aluminum nitride sintered compact, a silicon carbide sintered compact, or a glass ceramic sintered compact; quartz crystal; glass; silicon; or the like. The substrate body 21 has an upper main surface and a lower main surface. The upper main surface (main surface on the +Y' side) of the substrate body 21 will be referred to as the "front surface", and the lower main surface (main surface on the -Y' side) of the substrate body 21 will be referred to as the "back surface".

[0036] The four corners of the substrate body 21 are cut out so that each of the cut portions has a sectoral shape having a center angle of 90 degrees. However, for convenience of description, arc-shaped portions that are formed by cutting out the corners will be referred to as "corners".

[0037] The outer electrodes 22 and 26 are disposed on an end portion of the front surface of the substrate body 21 in the long-side direction so as to be arranged in the short-side direction. To be specific, the outer electrode 22 is a rectangular conductor layer that is disposed near the corner on the -Z' and +X side of the front surface of the substrate body 21. The outer electrode 26 is a rectangular conductor layer that is disposed near the corner on the -Z' and -X side of the front surface of the substrate body 21.

[0038] The outer electrodes 40, 42, 44, and 46 are disposed near the respective corners of the back surface of the substrate body 21. The outer electrode 40 is a square conductor layer that is disposed near the corner on the -Z' and -X side of the back surface of the substrate body 21. The outer electrode 40 is in contact with the corner on the -Z' and -X side of the back surface of the substrate body 21. The outer electrode 42 is a square conductor layer that is disposed near the corner on the -Z' and +X side of the back surface of the substrate body 21. The outer electrode 42 is in contact with the corner on the -Z' and +X side of the back surface of the substrate body 21. The outer electrode 44 is a square conductor layer that is disposed near the corner on the +Z' and -X side of the back surface of the substrate body 21. The outer electrode 44 is in contact with the corner on the +Z' and -X side of the back surface of the substrate body 21. The outer electrode 46 is a square conductor layer that is disposed near the corner on the +Z' and +X side of the back

surface of the substrate body 21. The outer electrode 46 is in contact with the corner on the +Z' and +X side of the back surface of the substrate body 21.

[0039] The wiring line 24 is a linear conductor layer that is disposed on the front surface of the substrate body 21 and extends from the outer electrode 22 in the +Z' direction. An end portion of the wiring line 24 in the +Z' direction is in contact with the corner on the +Z' and +X side of the front surface of the substrate body 21. The via conductor 25 covers a curved surface that is formed by cutting out the corner on the +Z' and +X side of the substrate body 21 and connects an end portion of the wiring line 24 in the +Z' direction and the outer electrode 46 to each other. The wiring line 27 is a linear conductor layer that extends from the outer electrode 26 in the -Z' and -X direction. An end portion of the wiring line 27 in the -Z' and -X direction is in contact with the corner on the -Z' and -X side of the front surface of the substrate body 21. The via conductor 28 covers a curved surface that is formed by cutting out the corner on the -Z' and -X side of the substrate body 21 and connects an end portion of the wiring line 27 in the -Z' and -X direction and the outer electrode 40 to each other.

[0040] The wiring line 49 is disposed on the back surface of the substrate body 21 and connects the outer electrode 42 and the outer electrode 44 to each other.

[0041] The outer electrodes 22, 26, 40, 42, 44, and 46; the wiring lines 24, 27, and 49; and the via conductors 25 and 28 have a three-layer structure. To be specific, the three-layer structure is formed by stacking a molybdenum layer, a nickel layer, and a gold layer from below.

[0042] The quartz crystal resonator 16 includes the quartz crystal blank 17, outer electrodes 97 and 98, excitation electrodes 100 and 101, and extension electrodes 102 and 103. The quartz crystal blank 17 is plate-shaped and is rectangular when seen from above. The upper main surface of the quartz crystal blank 17 will be referred to as the "front surface", and the lower main surface of the quartz crystal blank 17 will be referred to as the "back surface".

[0043] The quartz crystal blank 17 is an AT-cut quartz crystal blank that is cut from, for example, a rough quartz crystal at a predetermined angle. The AT-cut quartz crystal blank 17 is cut as follows: when an X axis, a Y axis, and a Z axis are the crystal axes of an artificial quartz crystal and a Y' axis and the Z' axis are axes that are obtained by rotating the Y axis and the Z axis around the X axis by 35 degrees 15 ± 1 minutes 30 seconds in the direction from the Y axis toward the Z axis, the quartz crystal blank 17 has a main surface that is parallel to a plane defined by the X axis and the Z' axis. As illustrated in FIG. 2, the long sides of the front surface and the back surface of the quartz crystal blank 17 are substantially parallel to the Z' axis of the quartz crystal blank 17. The short sides of the front surface and the back surface of the quartz crystal blank 17 are substantially parallel to the X axis of the quartz crystal blank 17. The thickness of the quartz crystal blank 17 in a direction perpendicular to the front surface and the back surface of the quartz crystal blank 17 is substantially parallel to the Y' axis of the quartz crystal blank 17. Here, "substantially parallel" allows deviation within about ± 1 degree relative to the Z' axis and the X axis. A quartz crystal resonator unit using an AT-cut quartz crystal blank can be manufactured so as to have extremely high frequency stability in a wide temperature range and high durability. Moreover, an AT-cut quartz crystal resonator includes a thickness shear vibration mode

as a main vibration. The quartz crystal blank 17 is beveled, as described below in detail. In each of FIGS. 2 and 3, beveled portions are not illustrated.

[0044] The quartz crystal resonator unit is sized so that the length in the long-side direction is 2.0 mm and the width in the short-side direction is 1.6 mm. To achieve this size, in consideration of the thickness of a package wall, bleeding of a molding compound, and the precision of mounting an element, the quartz crystal blank 17 is designed so as to have a length of 1.5 mm or smaller in the long-side direction and a width of 1.0 mm or smaller in the short-side direction.

[0045] The outer electrode 97 is a conductor layer that is disposed in a region including the corner on the -Z' and +X side of the quartz crystal blank 17. The outer electrode 97 is formed on the front surface and the back surface of the quartz crystal blank 17 and also on side surfaces on the +X side and the -Z' side of the quartz crystal blank 17. The outer electrode 98 is a conductor layer that is disposed in a region including the corner on the -Z' and -X side of the quartz crystal blank 17. The outer electrode 98 is formed on the front surface and the back surface of the quartz crystal blank 17 and also on side surfaces on the -X side and the -Z' side of the quartz crystal blank 17. Thus, the outer electrodes 97 and 98 are arranged along a short side of the quartz crystal blank 17.

[0046] The excitation electrode 100 is disposed at the center of the front surface of the quartz crystal blank 17 and is rectangular when seen from above. The excitation electrode 101 is disposed at the center of the back surface of the quartz crystal blank 17 and is rectangular when seen from above. The excitation electrode 100 and the excitation electrode 101 completely overlap each other when seen from above.

[0047] The extension electrode 102 is disposed on the front surface of the quartz crystal blank 17 and connects the outer electrode 97 and the excitation electrode 100 to each other. The extension electrode 103 is disposed on the back surface of the quartz crystal blank 17 and connects the outer electrode 98 and the excitation electrode 101 to each other. The outer electrodes 97 and 98, the excitation electrodes 100 and 101, and the extension electrodes 102 and 103 are each formed, for example, by stacking a gold layer on a chrome underlying layer.

[0048] The quartz crystal resonator 16 is mounted on the front surface of the substrate 12. To be specific, the outer electrode 22 and the outer electrode 97 are fixed to each other so as to be electrically connected to each other by using an electroconductive adhesive 210, and the outer electrode 26 and the outer electrode 98 are fixed to each other so as to be electrically connected to each other by using an electroconductive adhesive 212.

[0049] The metal cap 14 is a housing that has a rectangular opening. The metal cap 14 is made, for example, by plating a base metal, such as an iron-nickel alloy or a cobalt-nickel alloy, with nickel and gold. In the present embodiment, the metal cap 14 is a rectangular-parallelepiped box whose lower side is open. The metal cap 14 is made by plating a base metal, which is an iron-nickel alloy, with nickel and gold.

[0050] The adhesive 50 is rectangular frame-shaped and has a shape that corresponds to the outer edge of the opening of the metal cap 14. The adhesive 50 is made of, for example, low-melting point glass, a resin, or a metal, and fixes the metal cap 14 to the substrate 12. Thus, the front

surface of the substrate body 21 and the metal cap 14 form a hermetically sealed space Sp. Accordingly, the quartz crystal resonator 16 is covered by the metal cap 14 and contained in the hermetically sealed space Sp. Since the metal cap 14 is in close contact with the substrate body 21 via the adhesive 50, the inside of the hermetically sealed space Sp is maintained in a vacuum state. However, the inside may be in an atmospheric state.

[0051] (Details of Quartz Crystal Blank)

[0052] Hereinafter, details of the quartz crystal blank 17 will be described with reference to the drawings. FIG. 4 is a sectional view taken along line B-B of FIG. 2. FIG. 5 is a sectional view taken along line C-C of FIG. 2. FIG. 6 is a top view of the quartz crystal blank 17. FIG. 7 is an enlarged view of a region A1.

[0053] In order to reduce the CI value, the quartz crystal blank 17 according to the present embodiment satisfies the following conditions.

[0054] Condition 1: The frequency of a main vibration of the quartz crystal blank 17 is in the range of 24.5 MHz to 28.5 MHz.

[0055] Condition 2: The long sides of the front surface and the back surface of the quartz crystal blank 17 are substantially parallel to the Z' axis of the quartz crystal blank 17.

[0056] Condition 3: The short sides of the front surface and the back surface of the quartz crystal blank 17 are substantially parallel to the X axis of the quartz crystal blank 17.

[0057] Condition 4: The quartz crystal blank 17 is beveled so that, as illustrated in FIGS. 4 and 5, the thickness of portions of the quartz crystal blank 17 near the outer edges of the front surface and the back surface of the quartz crystal blank 17 is smaller than the thickness of a portion of the quartz crystal blank 17 near the centers of the front surface and the back surface of the quartz crystal blank 17.

[0058] Condition 5: $13.92 \leq W/T \leq 14.44$ is satisfied, where W is the length of regions A1, A4, and A5 of the quartz crystal blank 17 in the short-side direction, and T is the thickness of the region A1 of the quartz crystal blank 17. The regions A1, A4, and A5 will be described below.

[0059] <Regarding Condition 1>

[0060] The frequency of the main vibration of the quartz crystal blank 17 depends on the thickness T of the quartz crystal blank 17. Accordingly, the thickness T of the quartz crystal blank 17 is set in the range of 0.0586 mm to 0.0682 mm.

[0061] <Regarding Conditions 2 and 3>

[0062] In general, a quartz crystal blank is fixed to a substrate by bonding a portion of the quartz crystal blank near a short side thereof to the substrate by using an electroconductive adhesive. Moreover, it is known that the vibration direction of a thickness shear vibration of an AT-cut quartz crystal blank is the X-axis direction. Accordingly, an existing quartz crystal blank whose long sides are parallel to the X axis is likely to influence the substrate due to vibration leakage via the electroconductive adhesive near the short side. In contrast, in the AT-cut quartz crystal blank 17 according to the present embodiment, vibration leakage to a Z' axis region is small, because the long sides are parallel to the Z' axis. Therefore, even when the quartz crystal blank 17 is fixed to the substrate 12 by bonding a portion of the quartz crystal blank 17 near a short side thereof by using the electroconductive adhesives 210 and 212, the influence of vibration leakage on the substrate 12 is

small. Accordingly, with the AT-cut quartz crystal blank according to the present embodiment, the influence of vibration leakage is smaller and the CI value is better than a quartz crystal blank whose long sides are parallel to the X axis.

[0063] <Regarding Condition 4>

[0064] As illustrated in FIG. 6, the quartz crystal blank 17 includes regions A1 to A5 when seen from above. The region A1 is a rectangular region including the center of the front surface when seen from above. However, the shape of the region A1 may be non-rectangular when seen from above and may be, for example, elliptical. The region A2 is a rectangular region adjacent to the region A1 on the +Z' side. The region A2 is in contact with the entirety of a short side of the front surface on the +Z' side and with end portions, in the +Z' direction, of long sides of the front surface on the -X side and +X side. That is, the region A2 is positioned at an end portion of the quartz crystal blank 17 in the +Z' direction. The region A3 is a rectangular region adjacent to the region A1 on the -Z' side. The region A3 is in contact with the entirety of a short side of the front surface on the -Z' side and with end portions, in the -Z' direction, of the long sides of the front surface on the -X side and +X side. That is, the region A3 is positioned at an end portion of the quartz crystal blank 17 in the -Z' direction.

[0065] The region A4 is a rectangular region that is adjacent to the region A1 on the -X side and interposed between the regions A2 and A3 from the left and right sides. The region A4 is in contact with a portion, excluding both ends, of a long side of the front surface on the -X side. That is, the region A4 is positioned at an end portion of the quartz crystal blank 17 in the -X direction. The region A5 is a rectangular region that is adjacent to the region A1 on the +X side and interposed between the regions A2 and A3 from the right and left sides. The region A5 is in contact with a portion, excluding both ends, of a long side of the front surface on the +X side. That is, the region A5 is positioned at an end portion of the quartz crystal blank 17 in the +X direction.

[0066] As illustrated in FIGS. 4 and 5, the thickness T of the region A1 is substantially uniform. However, the front surface and back surface of the region A1 are slightly curved. Accordingly, as illustrated in FIG. 7, the region A1 that is substantially uniform is a region having a thickness in the range of $(T_{\max} - 2 \mu\text{m})$ to T_{\max} , where T_{\max} is the maximum value of the thickness of the quartz crystal blank in the region A1. The region A1 is a region that includes the center of the front surface and that is continuous. The thickness T of the region A1, which is substantially uniform, has the value T_{\max} .

[0067] As illustrated in FIGS. 4 and 5, the thicknesses of the regions A2 to A5 are smaller than the thickness T of the region A1. In the present embodiment, the thicknesses of the regions A2 to A5 continuously decrease with increasing distance from the region A1. In the present embodiment, the front surfaces and the back surfaces of the regions A2 to A5 are convex surfaces.

[0068] <Regarding Condition 5>

[0069] $13.92 \leq W/T \leq 14.44$ is satisfied, where W is the length of the regions A1, A4, and A5 of the quartz crystal blank 17 in the short-side direction, and T is the thickness of the region A1 of the quartz crystal blank 17. Preferably, $13.95 \leq W/T \leq 14.22$ is satisfied, and more preferably $14.07 \leq W/T \leq 14.18$ is satisfied.

[0070] <Regarding Other Conditions>

[0071] Preferably, in addition to the conditions 1 to 5, $0.50 \leq RL/L \leq 0.95$ is satisfied, where L is the length of the regions A1 to A3 in the long-side direction, and RL is the length of the region A1 in the long-side direction; and $0.50 \leq RW/W \leq 0.95$ is satisfied, where RW is the length of the region A1 in the short-side direction. More preferably, $0.50 \leq RL/L \leq 0.67$ is satisfied, where L is the length of the regions A1 to A3 in the long-side direction, and RL is the length of the region A1 in the long-side direction; and $0.50 \leq RW/W \leq 0.66$ is satisfied, where RW is the length of the region A1 in the short-side direction. Further preferably, $0.59 \leq RL/L \leq 0.61$ is satisfied, where L is the length of the regions A1 to A3 in the long-side direction, and RL is the length of the region A1 in the long-side direction; and $0.55 \leq RW/W \leq 0.58$ is satisfied, where RW is the length of the region A1 in the short-side direction. Here, the length RL is the length of a portion of the region A1 extending in the long-side direction and passing through a point in the region A1 where the thickness is T_{\max} . The length RW is the length of a portion of the region A1 extending in the short-side direction and passing through the point in the region A1 where the thickness is T_{\max} .

[0072] (Method of Manufacturing Quartz Crystal Resonator Unit)

[0073] Hereinafter, a method of manufacturing the quartz crystal resonator unit 10 will be described with reference to the drawings.

[0074] First, a method of manufacturing the substrate 12 will be described. A mother substrate in which a plurality of substrate bodies 21 are arranged in a matrix pattern is prepared. The mother substrate is made from, for example, a ceramic insulating material, such as an aluminum oxide sintered compact, a mullite sintered compact, an aluminum nitride sintered compact, a silicon carbide sintered compact, or a glass ceramic sintered compact; quartz crystal; glass; silicon; or the like.

[0075] Next, through-holes are formed by irradiating, with a beam, portions of the mother substrate corresponding to the four corners of the substrate body 21.

[0076] Next, underlying electrodes of the outer electrodes 22, 26, 40, 42, 44, and 46; the wiring lines 24, 27, and 49; and the via conductors 25 and 28 are formed on or in the substrate body 21.

[0077] To be specific, a molybdenum layer is printed on the mother substrate and dried. Subsequently, the molybdenum layer is fired. Thus, the underlying electrodes of the outer electrodes 22, 26, 40, 42, 44, and 46; the wiring lines 24, 27, and 49; and the via conductors 25 and 28 are formed.

[0078] Next, the underlying electrodes of the outer electrodes 22, 26, 40, 42, 44, and 46; the wiring lines 24, 27, and 49; and the via conductors 25 and 28 are plated with nickel and gold in this order. Thus, the outer electrodes 22, 26, 40, 42, 44, and 46; the wiring lines 24, 27, and 49; and the via conductors 25 and 28 are formed.

[0079] Next, the mother substrate is divided into a plurality of substrate bodies 21 by using a dicer.

[0080] Next, a method of manufacturing the quartz crystal resonator 16 will be described. The quartz crystal blank 17, which is rectangular plate-shaped, is obtained by AT-cutting a rough quartz crystal. At this time, the rough quartz crystal is cut so that the long sides of the front surface and the back surface of the quartz crystal blank 17 are substantially parallel to the Z' axis of the quartz crystal blank 17 and the

short sides of the front surface and the back surface of the quartz crystal blank 17 are substantially parallel to the X axis of the quartz crystal blank 17.

[0081] Next, the quartz crystal blank 17 is beveled by using a barrel finishing apparatus. Thus, ridge portions of the quartz crystal blank 17 are ground, and, as illustrated in FIGS. 4 and 5, the quartz crystal blank 17 has a cross-sectional shape such that the thickness thereof decreases with increasing distance from the center of the front surface.

[0082] Next, the outer electrodes 97 and 98, the excitation electrodes 100 and 101, and the extension electrodes 102 and 103 are formed on the quartz crystal blank 17. Since the outer electrodes 97 and 98, the excitation electrodes 100 and 101, and the extension electrodes 102 and 103 can be formed through a general process, the description of the process will be omitted.

[0083] Next, the quartz crystal resonator 16 is mounted on the front surface of the substrate body 21. To be specific, as illustrated in FIGS. 2 and 3, the outer electrode 22 and the outer electrode 97 are bonded to each other by using the electroconductive adhesive 210, and the outer electrode 26 and the outer electrode 98 are bonded to each other by using the electroconductive adhesive 212.

[0084] Next, the metal cap 14 is attached to the substrate 12 by using the adhesive 50. Through the process described above, the quartz crystal resonator unit 10 is completed.

Advantageous Effects

[0085] With the quartz crystal blank 17 and the quartz crystal resonator unit 10 according to the present embodiment, the CI value can be reduced. To be more specific, as illustrated in FIGS. 4 and 5, the quartz crystal blank 17 has a sectional shape such that the thickness thereof decreases with increasing distance from the center of the front surface. Thus, the vibration energy of the main vibration of the quartz crystal blank 17 is confined in the region A1. The excitation electrodes 100 and 101 are disposed on the region A1. As a result, the main vibration is efficiently converted into an electric signal, and the electric signal is output from the excitation electrodes 100 and 101. Thus, with the quartz crystal blank 17 and the quartz crystal resonator unit 10, the CI value can be reduced.

[0086] With the quartz crystal blank 17 and the quartz crystal resonator unit 10, the CI value can be reduced also for the following reasons. FIG. 8 is a graph representing the relationship between the frequencies of a main vibration and sub-vibrations and W/T of a quartz crystal blank 17 in which the frequency of the main vibration is 24.5 MHz. FIG. 9 is a graph representing the relationship between the frequencies of a main vibration and sub-vibrations and W/T of a quartz crystal blank 17 in which the frequency of the main vibration is 25.0 MHz. FIG. 10 is a graph representing the relationship between the frequencies of a main vibration and sub-vibrations and W/T of a quartz crystal blank 17 in which the frequency of the main vibration is 28.5 MHz. In each of FIGS. 8 to 10, the triangles represent the main vibration, and the squares and the rhombuses represent the sub-vibrations.

[0087] In the quartz crystal blank 17 and the quartz crystal resonator unit 10, sub-vibrations occur in addition to a main vibration. The main vibration is a thickness shear vibration. The frequency of the main vibration depends on the thickness T of the quartz crystal blank 17. The sub-vibrations, which are vibrations other than the main vibration, occur due to extension and contraction of the quartz crystal blank 17 in the short-side direction, extension and contraction of the quartz crystal blank 17 in the long-side direction, warping of the quartz crystal blank 17, and the like. The frequencies of the sub-vibrations depend on the length L, the width W, and

the like. Such sub-vibrations are so-called spurious vibrations. As can be understood from the results of simulation described below, in which W/T was changed while keeping the length L of the quartz crystal blank 17 in the long-side direction constant, sub-vibrations that may occur in the quartz crystal blank 17 and the quartz crystal resonator unit 10 can be suppressed by adjusting W/T.

[0088] Here, the CI value of the quartz crystal blank 17 and of the quartz crystal resonator unit 10 can be reduced by designing the quartz crystal blank 17 and the quartz crystal resonator 16 so as to separate the frequency of the main vibration from the frequencies of the sub-vibrations. The inventors studied the relationship between W/T and the frequencies of the main vibration and the sub-vibrations by performing computer simulation. In the computer simulation, for three types of quartz crystal blanks 17 having main vibration frequencies of 24.5 MHz, 25.0 MHz, and 28.5 MHz, the width W was changed while keeping the thickness T constant. The simulation conditions are as follows.

[0089] (1) 24.5 MHz

[0090] thickness T: 0.0682 mm

[0091] length L: 1.350 mm

[0092] length RL: 0.760 mm

[0093] RW/W: 0.54

[0094] (2) 25.0 MHz

[0095] thickness T: 0.0668 mm

[0096] length L: 1.350 mm

[0097] length RL: 0.760 mm

[0098] RW/W: 0.54

[0099] (3) 28.5 MHz

[0100] thickness T: 0.0586 mm

[0101] length L: 1.350 mm

[0102] length RL: 0.760 mm

[0103] RW/W: 0.54

[0104] By performing simulation under the above conditions, the results shown in FIGS. 8 to 10 were obtained. Then, the inventors investigated preferable W/T on the basis of the simulation results.

[0105] As can be seen from FIG. 8, when the frequency of the main vibration is 24.5 MHz, the main vibration and sub-vibrations 1 and 2 do not intersect if W/T is in the range of 13.92 to 14.45. That is, if W/T is in the range of 13.92 to 14.45 (that is, T is 0.0682 mm and W is in the range of 0.949 mm to 0.985 mm), the frequency of the main vibration is separated from the frequencies of the sub-vibrations.

[0106] As can be seen from FIG. 9, when the frequency of the main vibration is 25.0 MHz, the main vibration and the sub-vibrations 1 and 2 do not intersect if W/T is in the range of 13.92 to 14.44. That is, if W/T is in the range of 13.92 to 14.44 (that is, T is 0.0668 mm and W is in the range of 0.930 mm to 0.965 mm), the frequency of the main vibration is separated from the frequencies of the sub-vibrations.

[0107] As can be seen from FIG. 10, when the frequency of the main vibration is 28.5 MHz, the main vibration and the sub-vibrations 1 and 2 do not intersect if W/T is in the range of 13.92 to 14.45. That is, if W/T is in the range of 13.92 to 14.45 (that is, T is 0.0586 mm and W is in the range of 0.816 mm to 0.847 mm), the frequency of the main vibration is separated from the frequencies of the sub-vibrations.

[0108] These results show that, when the frequency of the main vibration of the quartz crystal blank 17 is in the range of 24.5 MHz to 28.5 MHz, the frequency of the main vibration is separated from the frequencies of the sub-vibrations if $13.92 \leq W/T \leq 14.44$. Thus, in the quartz crystal blank 17 in which the frequency of the main vibration is in the range of 24.5 MHz to 28.5 MHz, the CI value can be reduced if $13.92 \leq W/T \leq 14.44$.

[0109] Since a main vibration and sub-vibrations can be individually analyzed by using simulation, simulation has an advantage in that a range in which the influence of sub-vibrations on a main vibration in the range of 24.5 MHz to 28.5 MHz can be obtained by using the CI value. However, by measuring the CI values of actual samples, although only the CI value in which a main vibration and sub-vibrations are superposed can be obtained, it is possible to obtain detailed measurement results that reflect actual variations in dimensions, shapes, material characteristics, and the like. Therefore, the inventors performed an experiment using samples that were actually made as described below, and obtained a more preferable range of W/T in the frequency range of 24.5 MHz to 28.5 MHz. To be more specific, the inventors made forty pieces of each of first to eleventh samples of the quartz crystal resonator unit 10. The conditions for the first to eleventh samples are as follows.

[0110] (1) First to Fourth Samples (Frequency of Main Vibration: 25.0 MHz)

TABLE 1

	First Sample	Second Sample	Third Sample	Fourth Sample
T [mm]	0.0668	0.0668	0.0668	0.0668
L [mm]	1.350	1.350	1.350	1.350
RL [mm]	0.760	0.760	0.760	0.760
W [mm]	0.940	0.943	0.945	0.950
RW [mm]	0.505	0.507	0.508	0.511

[0111] (2) Fifth to Eighth Samples (Frequency of Main Vibration: 27.0 MHz)

TABLE 2

	Fifth Sample	Sixth Sample	Seventh Sample	Eighth Sample
T [mm]	0.0619	0.0619	0.0619	0.0619
L [mm]	1.350	1.350	1.350	1.350
RL [mm]	0.850	0.850	0.850	0.850
W [mm]	0.863	0.868	0.873	0.878
RW [mm]	0.538	0.540	0.542	0.544

[0112] (3) Ninth to Eleventh Samples (Frequency of Main Vibration: 27.12 MHz)

TABLE 3

	Ninth Sample	Tenth Sample	Eleventh Sample
T [mm]	0.0616	0.0616	0.0616
L [mm]	1.350	1.350	1.350
RL [mm]	0.850	0.850	0.850

TABLE 3-continued

	Ninth Sample	Tenth Sample	Eleventh Sample
W [mm]	0.863	0.868	0.873
RW [mm]	0.538	0.540	0.542

[0113] For each of the first to eleventh samples, the CI value was measured. In the experiment, the ambient temperature was changed from -30°C . to 85°C . As the CI value, the maximum value for each sample when the temperature was changed from -30°C . to 85°C . was used.

[0114] FIG. 11 is a graph representing the result of the experiment performed on the first to fourth samples (the frequency of the main vibration: 25.0 MHz). FIG. 12 is a graph representing the result of the experiment performed on the fifth to eighth samples (the frequency of the main vibration: 27.0 MHz). FIG. 13 is a graph representing the result of the experiment performed on the ninth to eleventh samples (the frequency of the main vibration: 27.12 MHz). In each of FIGS. 11 to 13, the vertical axis represents the CI value, and the horizontal axis represents the width W.

[0115] FIG. 11 shows measurements of the CI value for W in the range of 0.940 mm to 0.950 mm where the CI value was smaller than or equal to 60Ω , which is about twice the minimum CI value of 32Ω , in the case where the frequency of the main vibration was 25.0 MHz. In the case where the thickness T, which is determined from the frequency of the main vibration, was 0.0668 mm, the CI value was smaller than or equal to 60Ω and sufficiently low when W/T was in the range of 14.07 to 14.22.

[0116] FIG. 12 shows measurements of the CI value for W in the range of 0.863 mm to 0.878 mm where the CI value was smaller than or equal to 60Ω in the case where the frequency of the main vibration was 27.0 MHz. In the case where the thickness T, which is determined from the frequency of the main vibration, was 0.0619 mm, the CI value was smaller than or equal to 60Ω and sufficiently low when W/T was in the range of 13.95 to 14.20.

[0117] FIG. 13 shows measurements of the CI value for W in the range of 0.863 mm to 0.873 mm where the CI value was smaller than or equal to 60Ω in the case where the frequency of the main vibration was 27.12 MHz. In the case where the thickness T, which is determined from the frequency of the main vibration, was 0.0616 mm, the CI value was smaller than or equal to 60Ω and sufficiently low when W/T was in the range of 14.01 to 14.18.

[0118] Thus, it can be understood that, in the case where the frequency of the main vibration of the quartz crystal blank 17 is in the range of 25.0 MHz to 27.12 MHz, the CI value can be reduced to a level lower than or equal to 60Ω if $13.95 \leq W/T \leq 14.22$. Moreover, if $14.07 \leq W/T \leq 14.18$, the CI value can be further reduced.

[0119] Next, the inventors performed an experiment as described below and obtained preferable ranges of RL/L and RW/W. To be more specific, forty pieces of each of twelfth to twenty-fifth samples were made. Conditions for the twelfth to twenty-sixth samples were as follows.

[0120] (1) Twelfth to Seventeenth Samples (Frequency of Main Vibration: 25.0 MHz)

TABLE 4

	Twelfth Sample	Thirteenth Sample	Fourteenth Sample	Fifteenth Sample	Sixteenth Sample	Seventeenth Sample
T [mm]	0.0668	0.0668	0.0668	0.0668	0.0668	0.0668
L [mm]	1.350	1.350	1.350	1.350	1.350	1.350
RL [mm]	0.680	0.700	0.740	0.760	0.780	0.820
W [mm]	0.943	0.943	0.943	0.943	0.943	0.943
RW [mm]	0.468	0.480	0.500	0.507	0.522	0.550

[0121] (2) Eighteenth to Twenty-First Samples (Frequency of Main Vibration: 27.0 MHz)

TABLE 5

	Eighteenth Sample	Nineteenth Sample	Twentieth Sample	Twenty-first Sample
T [mm]	0.0619	0.0619	0.0619	0.0619
L [mm]	1.350	1.350	1.350	1.350
RL [mm]	0.750	0.800	0.850	0.900
W [mm]	0.868	0.868	0.868	0.868
RW [mm]	0.480	0.500	0.540	0.570

[0122] (3) Twenty-Second to Twenty-Fifth Samples (Frequency of Main Vibration: 27.12 MHz)

TABLE 6

	Twenty-second Sample	Twenty-third Sample	Twenty-fourth Sample	Twenty-fifth Sample
T [mm]	0.0616	0.0616	0.0616	0.0616
L [mm]	1.350	1.350	1.350	1.350
RL [mm]	0.750	0.800	0.850	0.900
W [mm]	0.868	0.868	0.868	0.868
RW [mm]	0.480	0.500	0.540	0.570

[0123] For each of the twelfth to twenty-fifth samples, the CI value was measured. In the experiment, the ambient temperature was changed from -30°C . to 85°C . As the CI value, the maximum value for each sample when the temperature was changed from -30°C . to 85°C . was used.

[0124] FIG. 14 is a graph representing the result of the experiment performed on the twelfth to seventeenth samples (the frequency of the main vibration: 25.0 MHz). FIG. 15 is a graph representing the result of the experiment performed on the eighteenth to twenty-first samples (the frequency of the main vibration: 27.0 MHz). FIG. 16 is a graph representing the result of the experiment performed on the twenty-second to twenty-fifth samples (the frequency of the main vibration: 27.12 MHz). In each of FIGS. 14 to 16, the vertical axis represents the CI value, and the horizontal axis represents RL/L and RW/W.

[0125] FIG. 14 shows measurements of the CI value for RW/W in the range of 0.50 to 0.58 and RL/L in the range of 0.50 to 0.61 where the CI value was smaller than or equal to 60Ω in a case where the frequency of the main vibration was 25.0 MHz.

[0126] FIG. 15 shows measurements of the CI value for RW/W in the range of 0.55 to 0.66 and RL/L in the range of 0.56 to 0.67 where the CI value was smaller than or equal to 60Ω in the case where the frequency of the main vibration was 27.0 MHz.

[0127] FIG. 16 shows measurements of the CI value for RW/W in the range of 0.55 to 0.66 and RL/L in the range of 0.56 to 0.67 where the CI value was smaller than or equal to 60Ω in the case where the frequency of the main vibration was 27.12 MHz.

[0128] If RL/L and RW/W are greater than 0.95, the vibration energy of the main vibration of the quartz crystal blank 17 cannot be sufficiently confined in the region A1. Therefore, preferably, the upper limit of RL/L and RW/W is 0.95.

[0129] From the result of the experiment performed on the samples in which the frequency of the main vibration of the quartz crystal blank 17 is in the range of 25.0 MHz to 27.12 MHz, the CI value can be reduced to a level lower than or equal to 60Ω if $0.50 \leq \text{RL}/L \leq 0.67$ and $0.50 \leq \text{RW}/W \leq 0.66$. Moreover, if $0.56 \leq \text{RL}/L \leq 0.61$ and $0.55 \leq \text{RW}/W \leq 0.58$, the CI value can be further reduced.

[0130] (Modification)

[0131] Hereinafter, a quartz crystal resonator unit 10a according to a modification will be described with reference to the drawings. FIG. 17 is a sectional view of the quartz crystal resonator unit 10a according to the modification.

[0132] As illustrated in FIG. 17, the quartz crystal resonator unit 10a according to the present modification includes a quartz crystal resonator 16 including a quartz crystal blank 17, and differs from the quartz crystal resonator unit 10 according to the embodiment described above in that a thermistor 60 is disposed on a back surface of a substrate 12. As the quartz crystal blank 17, a quartz crystal blank according to the embodiment described above can be used.

[0133] (Quartz Crystal Oscillator)

[0134] Hereinafter, a quartz crystal oscillator 300 including a quartz crystal blank 17 will be described with reference to the drawings. FIG. 18 is a sectional view of the quartz crystal oscillator 300.

[0135] As illustrated in FIG. 18, the quartz crystal oscillator 300 includes a quartz crystal resonator 16 including the quartz crystal blank 17, and differs from the quartz crystal resonator unit 10 shown in FIG. 3 in that an IC 302 is mounted on a back surface of a substrate 12. As the quartz crystal blank 17, a quartz crystal blank according to the embodiment described above can be used.

OTHER EMBODIMENTS

[0136] A quartz crystal blank and a quartz crystal resonator unit according to the present invention are not limited to the quartz crystal blank 17 and the quartz crystal resonator unit 10, and may be modified within the scope of the present invention.

[0137] The quartz crystal blank 17 has a shape such that the thickness thereof decreases with increasing distance from the center of the front surface in the short-side direction and in the long-side direction. However, the thickness of the quartz crystal blank 17 may decrease with increasing distance from the center of the front surface in the short-side direction or may decrease with increasing distance from the center of the front surface in the long-side direction. That is, it is sufficient that the thickness of the region A2 and the thickness of the region A3 are smaller than the thickness of the region A1 and/or the thickness of the region A4 and the thickness of the region A5 are smaller than the thickness of the region A1.

[0138] FIGS. 19 and 20 are sectional views of quartz crystal blanks 17a and 17b according to other embodiments. As illustrated in FIG. 19, a region having a larger thickness than the region A2 may be disposed on the +Z' side of the region A2; and a region having a larger thickness than the region A3 may be disposed on the -Z' side of the region A3. Likewise, a region having a larger thickness than the region A4 may be disposed on the -X side of the region A4. A region having a larger thickness than the region A5 may be disposed on the +X side of the region A5. That is, as long as the region A2 to A5, each of which has a smaller thickness than the region A1, are disposed around the region A1,

vibration energy of a main vibration is confined in the region A1. Therefore, other regions may be present or may not be present around the regions A2 to A5.

[0139] The regions A2 to A5, which have continuously-changing convex surfaces, may have concave surfaces or discontinuously-changing surfaces. That is, as illustrated in FIG. 20, the regions A2 to A5 may have step-like shapes.

[0140] As described above, the present invention can be used for a quartz crystal blank and a quartz crystal resonator unit and, in particular, advantageous in that the CI value can be reduced.

REFERENCE SIGNS LIST

- [0141] 10, 10a quartz crystal resonator unit
- [0142] 12 substrate
- [0143] 14 metal cap
- [0144] 16 quartz crystal resonator
- [0145] 17, 17a, 17b quartz crystal blank
- [0146] 21 substrate body
- [0147] 22, 26, 40, 42, 44, 46 outer electrode
- [0148] 50 adhesive
- [0149] 60 thermistor
- [0150] 100, 101 excitation electrode
- [0151] 300 quartz crystal oscillator
- [0152] A1 to A5 region

1. An AT-cut quartz crystal blank comprising:
 - a quartz crystal body that is rectangular in shape in a direction normal to a main surface thereof, the quartz crystal body having a first region including a center of the main surface in the direction normal to the main surface, a second region and a third region that are adjacent to the first region on opposed sides thereof along a long-side direction in which long sides of the quartz crystal body extend, and a fourth region and a fifth region that are adjacent to the first region on opposed sides thereof along a short-side direction in which short sides of the quartz crystal body extend, wherein the long sides of the main surface are substantially parallel to a Z' axis of the quartz crystal blank, wherein the short sides of the main surface are substantially parallel to an X axis of the quartz crystal blank, wherein a frequency of a main vibration of the quartz crystal blank is in a range of 24.5 MHz to 28.5 MHz, wherein a thickness of the first region is substantially uniform, wherein at least one of (1) a thickness of the second region and a thickness of the third region are smaller than the thickness of the first region, and (2) a thickness of the fourth region and a thickness of the fifth region are smaller than the thickness of the first region, and wherein $13.92 \leq W/T \leq 14.44$, where W is a length of the first region, the fourth region, and the fifth region along the short-side direction, and T is the thickness of the first region.
2. The quartz crystal blank according to claim 1, wherein $13.95 \leq W/T \leq 14.22$.
3. The quartz crystal blank according to claim 1, wherein $14.07 \leq W/T \leq 14.18$.
4. The quartz crystal blank according to claim 1, wherein the thickness of the second region and the thickness of the third region are smaller than the thickness of the first region,

and the thickness of the fourth region and the thickness of the fifth region are smaller than the thickness of the first region.

5. The quartz crystal blank according to claim 1, wherein the thickness of the second region and the thickness of the third region are smaller than the thickness of the first region.
6. The quartz crystal blank according to claim 1, wherein the thickness of the fourth region and the thickness of the fifth region are smaller than the thickness of the first region.
7. The quartz crystal blank according to claim 4, wherein the second region and the third region are positioned at opposed ends of the quartz crystal blank in the long-side direction, and wherein the fourth region and the fifth region are positioned at opposed ends of the quartz crystal blank in the short-side direction.
8. The quartz crystal blank according to claim 7, wherein a thickness of the quartz crystal blank decreases with increasing distance from the center of the main surface in the long-side direction and decreases with increasing distance from the center of the main surface in the short-side direction.
9. The quartz crystal blank according to claim 7, wherein a thickness of the quartz crystal blank decreases with increasing distance from the center of the main surface in the long-side direction.
10. The quartz crystal blank according to claim 7, wherein a thickness of the quartz crystal blank decreases with increasing distance from the center of the main surface in the short-side direction.
11. The quartz crystal blank according to claim 7, wherein $0.50 \leq RL/L \leq 0.95$, where L is a length of the first region, the second region, and the third region along the long-side direction, and RL is a length of the first region along the long-side direction, and wherein $0.50 \leq RW/W \leq 0.95$, where RW is a length of the first region along the short-side direction.
12. The quartz crystal blank according to claim 11, wherein $0.50 \leq RL/L \leq 0.67$, and wherein $0.50 \leq RW/W \leq 0.66$.
13. The quartz crystal blank according to claim 11, wherein $0.56 \leq RL/L \leq 0.61$, and wherein $0.55 \leq RW/W \leq 0.58$.
14. A quartz crystal resonator unit comprising: the quartz crystal blank according to claim 1.
15. The quartz crystal resonator unit according to claim 14, comprising:
 - a first outer electrode and a second outer electrode that are each arranged along a respective short side of the quartz crystal blank;
 - a substrate body; and
 - a third outer electrode and a fourth outer electrode that are each disposed on a respective main surface of the substrate body, wherein the first outer electrode and the third outer electrode are electrically connected to each other, and the second outer electrode and the fourth outer electrode are electrically connected to each other.
16. The quartz crystal resonator unit according to claim 15, further comprising:
 - a cap disposed on the substrate body and covering the quartz crystal resonator.

* * * * *