

(19)
(12)

(KR)
(Y1)

(51) 。 Int. Cl. 7
G11B 19/20

(45)
(11)
(24)

2003 03 15
20 - 0306575
2003 02 25

(21) 20 - 2002 - 0036562
(22) 2002 12 06
(62) 2002 - 0076893
: 2002 12 05

(73) , - 1 120 12 - 1

(72) - 1 12012 - 3
- - - 2 362 .

(74)
:
가 :

(54)

가 .
가

가 가

1
2
3
4
5
6
7 6

1 (10), (20), (30), (40)
(11) (10) (20) (1
0) (30) (40) (axle tube)(41) (10)
가 (42) (30) (31) (10)

(10) (10) (20) (30) 가
(10) (30) (10) (10) (10) (30)
"a" "b" (10) (10)
(10) (10) (10)

가 가

3 (41) (40), (40) (41)가 (42),
 (30) (41) 가 (20) (30) (40)
 (30) (20)가 (31) (10) (30) ,
 (30) (30) (20) (11) (10) (15)
 (30) (20) (11) (15) (10) (11) 가

(10)가 (30) (10) (10)
 (13) 가 (12) 4 5 (12)
 (12) 가 (30) 가 (10) (30)가 (10) (12)
 (30) (30) (30) (10) (12) (10)
 12) (12) (12) (12) (12)가
 (10)가 (131)가 (10)
 (131) 가 (13) 가 (13) (13) (13)

6 7 (30)가 (331)
 (32)가 (33) (32) 7
 (10) (30) 가 (10) 가 (10) (30)가 (30)
 (32) (30) (30) (30) (30)
 (10) (32) (331) (33)
 (331)가 (30) () 가 (30) 가
 (33) () 가 (30) 가
 (12, 32) (13, 33) 가 , 가 가

5.

4 ,

(boss) ,

,

6.

2 ,

7.

6 ,

,

,

8.

1 ,

9.

,

1 , ,

2

가

가

가

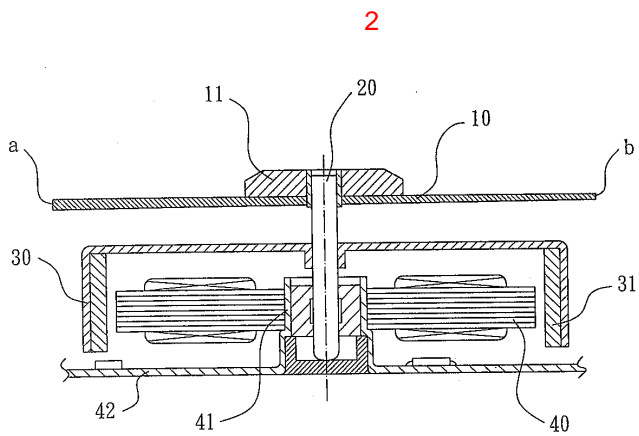
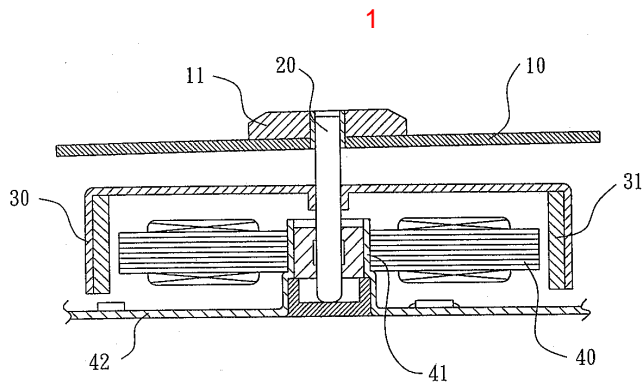

3

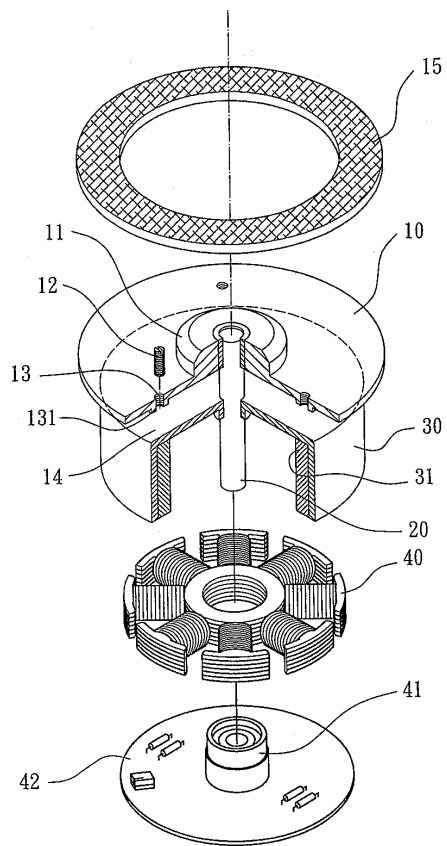

4

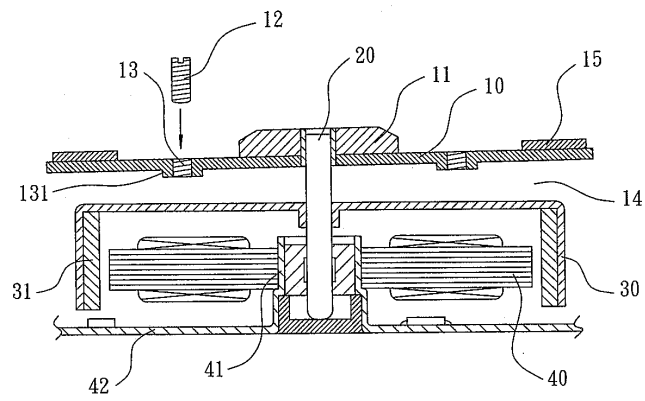

5

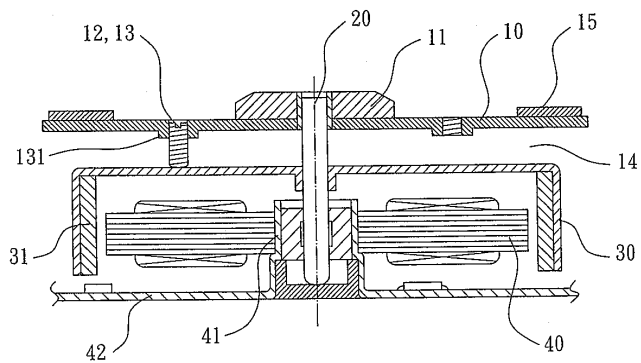

6

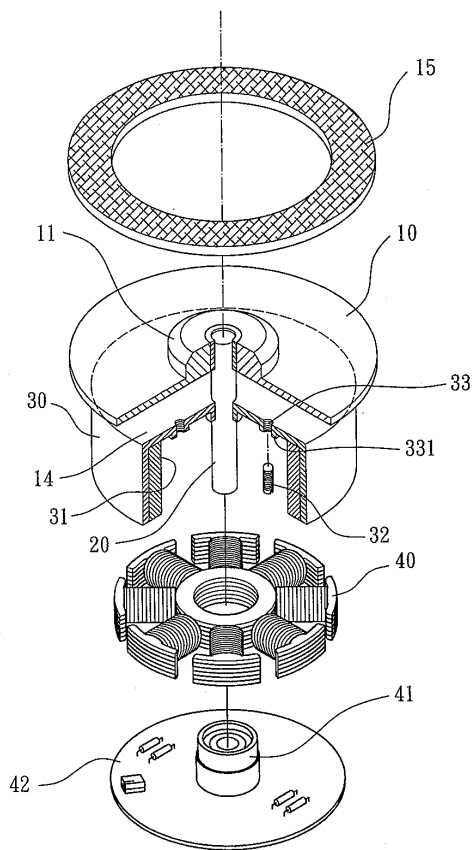

7

