



(19) **United States**

(12) **Patent Application Publication**

**Young et al.**

(10) **Pub. No.: US 2022/0094124 A1**

(43) **Pub. Date: Mar. 24, 2022**

(54) **BUS BAR AND POWER ELECTRONIC DEVICE WITH CURRENT SHAPING TERMINAL CONNECTOR AND METHOD OF MAKING A TERMINAL CONNECTOR**

*H02M 3/155* (2006.01)

*H05K 7/20* (2006.01)

*H01L 23/46* (2006.01)

*H01L 23/492* (2006.01)

(71) Applicant: **Transportation IP Holdings, LLC,**  
Norwalk, CT (US)

*H01L 23/00* (2006.01)

*H01L 25/11* (2006.01)

*H01R 43/16* (2006.01)

(72) Inventors: **Henry Todd Young,** Erie, PA (US);  
**Alvaro Jorge Mari Curbelo,**  
Oberschleissheim (DE); **Jason Daniel**  
**Kuttenkuler,** Erie, PA (US); **Tiziana**  
**Bertoncelli,** Muenchen (DE); **Sean**  
**Patrick Cillessen,** Erie, PA (US)

(52) **U.S. Cl.**

CPC ..... *H01R 25/162* (2013.01); *H02M 7/003*  
(2013.01); *H02G 5/005* (2013.01); *H02M*  
*3/155* (2013.01); *H05K 7/20927* (2013.01);  
*H02M 7/537* (2013.01); *H01L 23/492*  
(2013.01); *H01L 23/562* (2013.01); *H01L*  
*25/115* (2013.01); *H01R 43/16* (2013.01);  
*H05K 7/2089* (2013.01); *H01L 23/46*  
(2013.01)

(21) Appl. No.: **17/544,443**

(22) Filed: **Dec. 7, 2021**

**Related U.S. Application Data**

(60) Continuation-in-part of application No. 16/874,346,  
filed on May 14, 2020, now Pat. No. 11,239,618,  
which is a continuation-in-part of application No.  
16/149,946, filed on Oct. 2, 2018, now Pat. No.  
10,693,265, which is a division of application No.  
15/524,288, filed on May 4, 2017, now Pat. No.  
10,128,625, filed as application No. PCT/US2015/  
061217 on Nov. 18, 2015.

(60) Provisional application No. 62/081,179, filed on Nov.  
18, 2014.

**Publication Classification**

(51) **Int. Cl.**

*H01R 25/16* (2006.01)

*H02M 7/00* (2006.01)

*H02G 5/00* (2006.01)

(57)

**ABSTRACT**

A bus bar includes a load terminal connector comprising a conductive plate that extends from a first edge to an opposite second edge and extends from a third edge to an opposite fourth edge. The third and fourth edges extend from the first edge to the second edge. The plate includes a window opening located between the first and second edges and between the third and fourth edges. The plate also includes a slot extending into the plate from the first edge to the window opening. The plate includes first and second sets of openings configured to receive connections with first and second power terminals of switch packages. The first set of openings and the second set of openings are located on opposite sides of the slot.

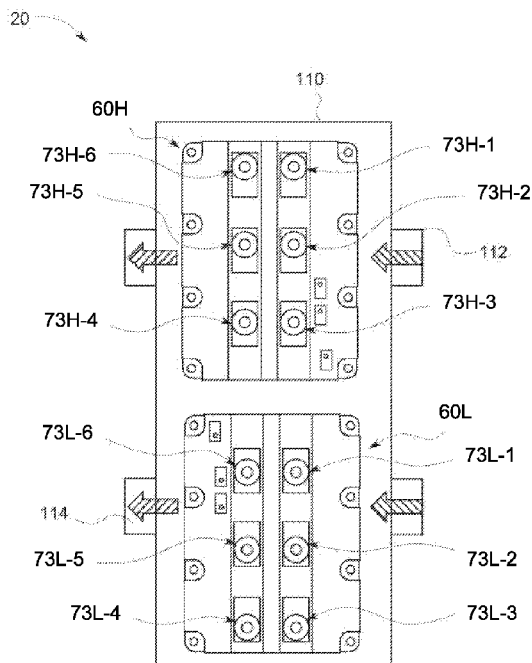

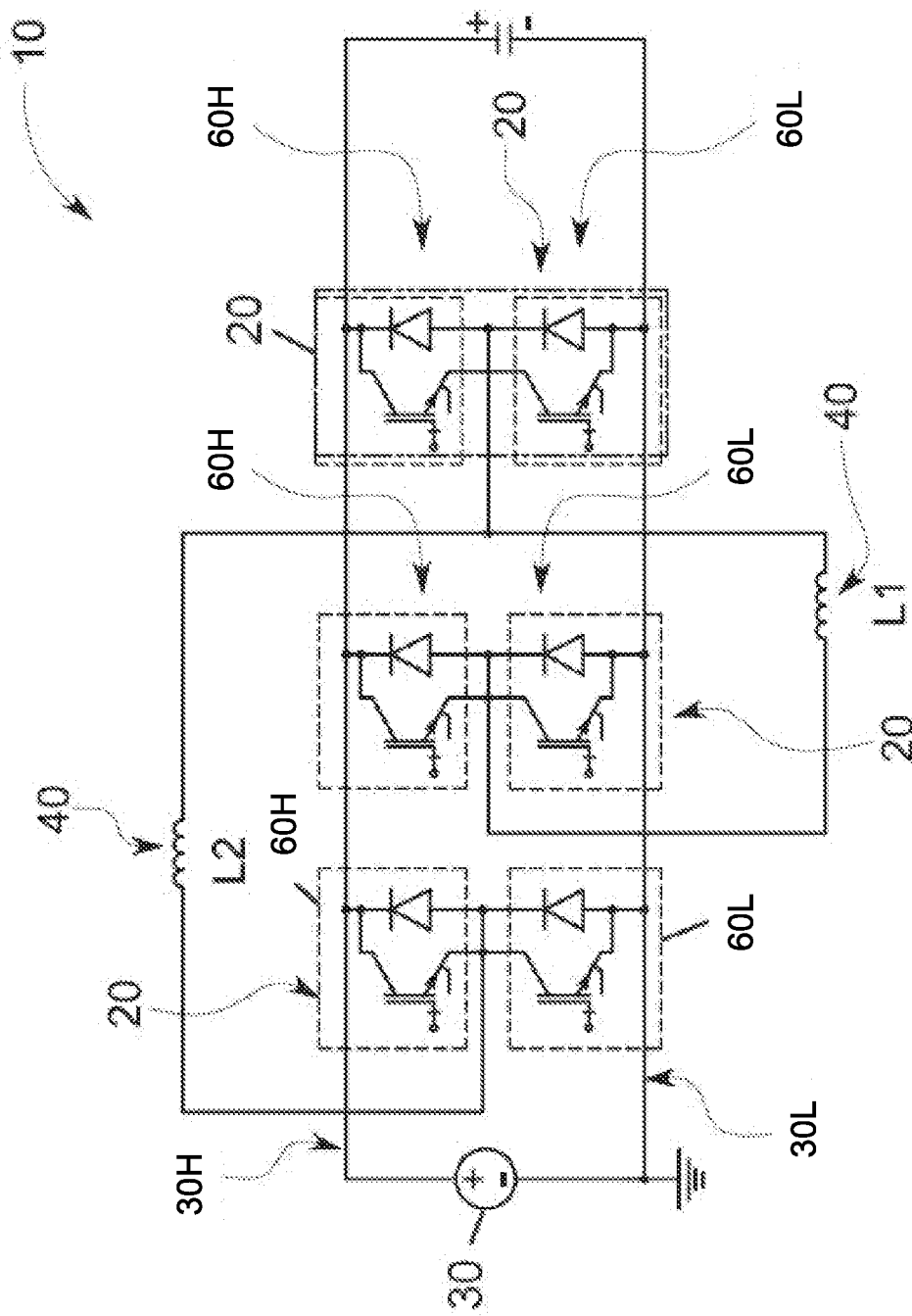

FIG. 1

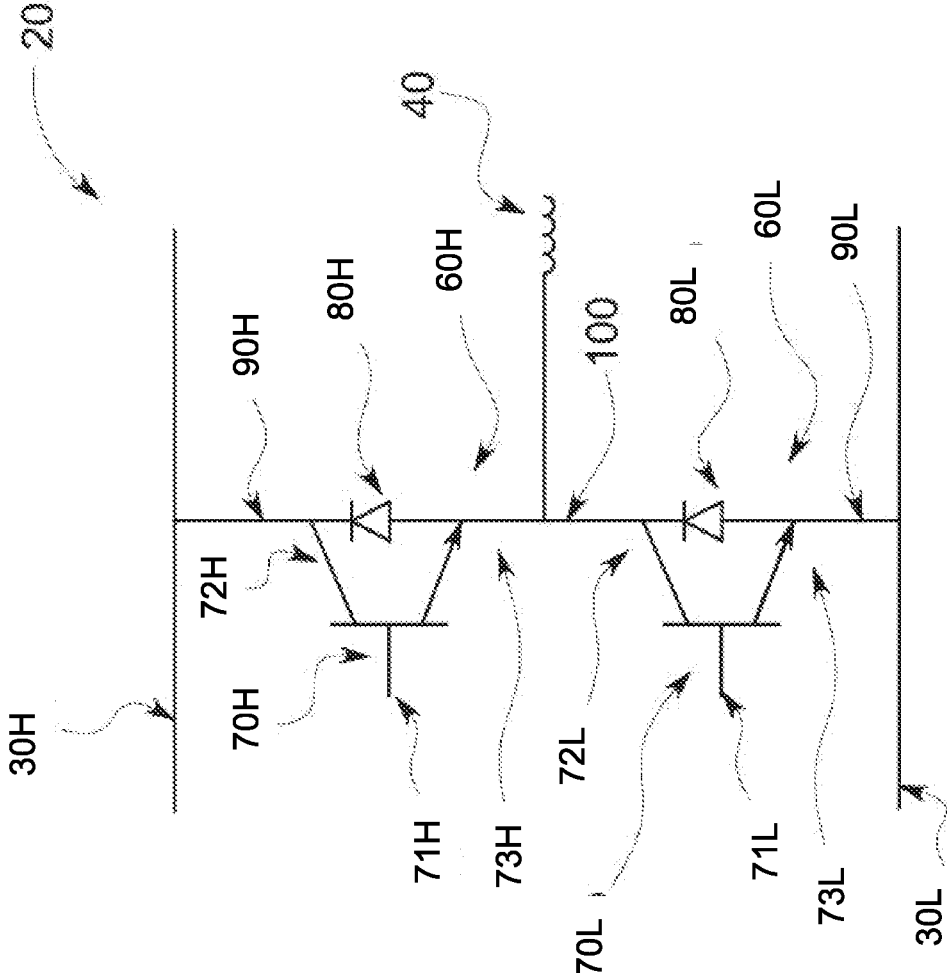

FIG. 2

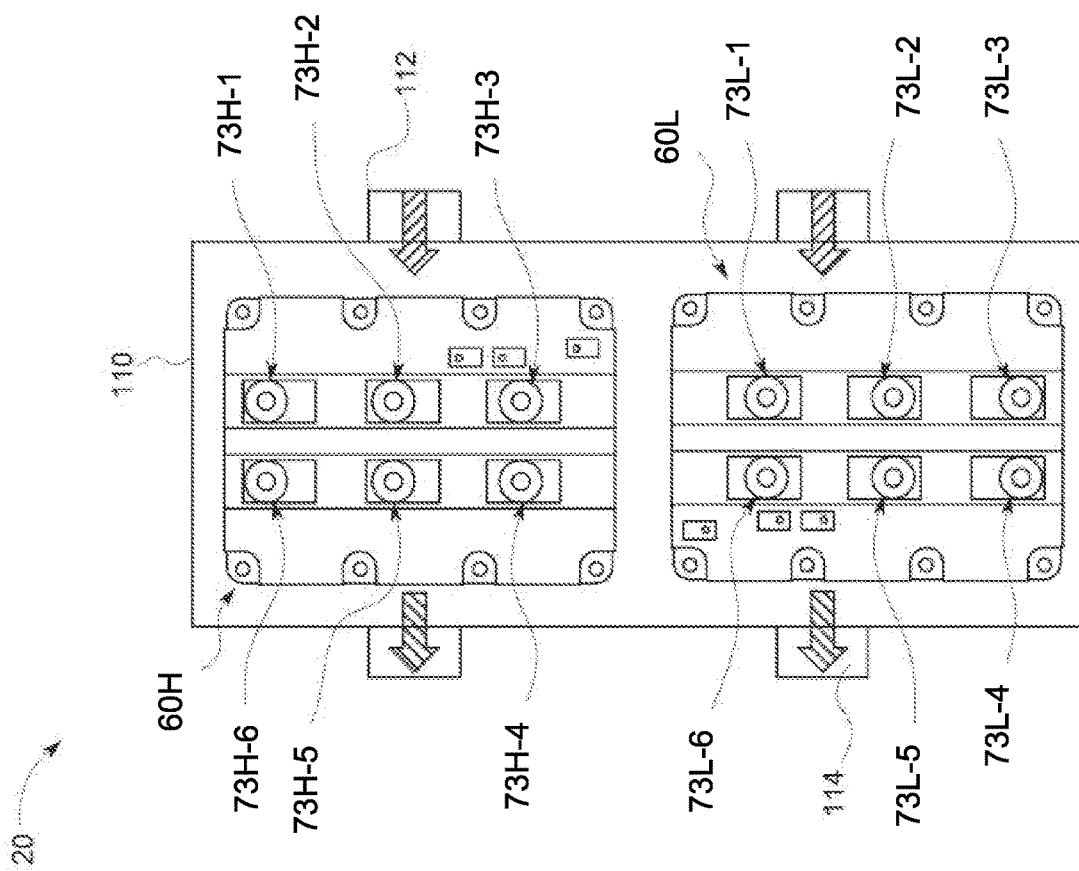

FIG. 3

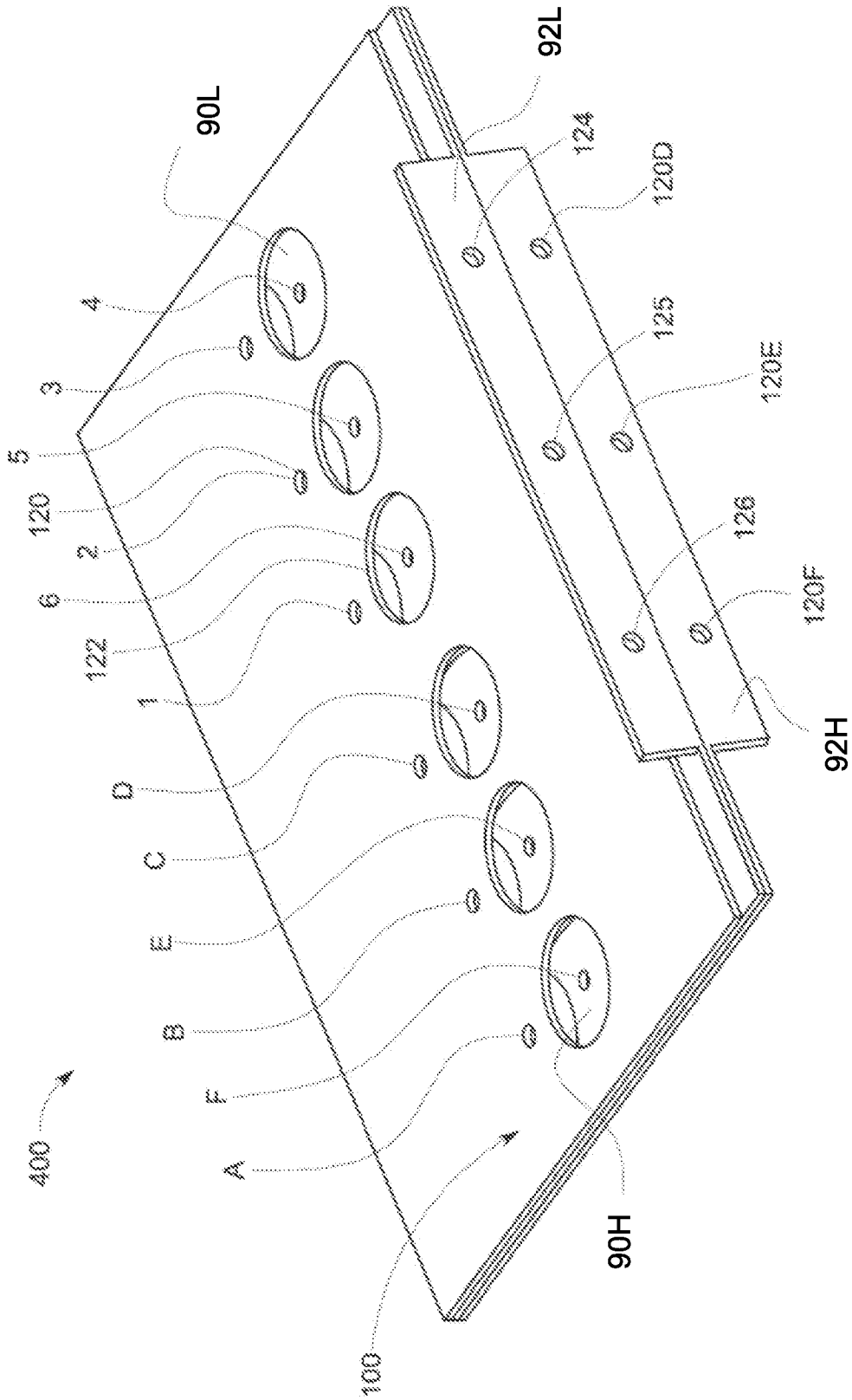

FIG. 4

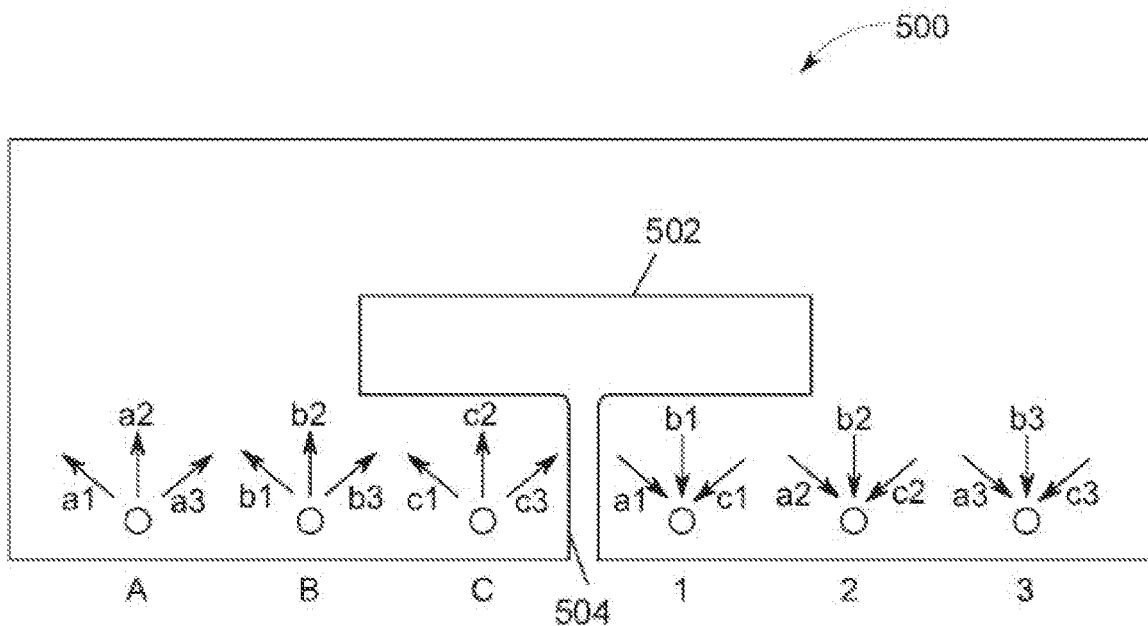

FIG. 5

R or L	a1	b1	c1	a2	b2	c2	a3	b3	c3
a1	a1	a1b1	a1c1	a1a2	a1b2	a1c2	a1a3	a1b3	a1c3
b1	a1b1	b1	b1c1	b1a2	b1b2	b1c2	b1a3	b1b3	b1c3
c1	a1c1	b1c1	c1	c1a2	c1b2	c1c2	c1a3	c1b3	c1c3
a2	a1a2	b1a2	c1a2	a2	a2b2	a2c2	a2a3	a2b3	a2c3
b2	a1b2	b1b2	c1b2	a2b2	b2	b2c2	b2a3	b2b3	b2c3
c2	a1c2	b1c2	c1c2	a2c2	b2c2	c2	c2a3	c2b3	c2c3
a3	a1a3	b1a3	c1a3	a2a3	b2a3	c2a3	a3	a3b3	a2c3
b3	a1b3	b1b3	c1b3	a2b3	b2b3	c2b3	a3b3	b3	b3c3
c3	a1c3	b1c3	c1c3	a2c3	b2c3	c2c3	a3c3	b3c3	c3

FIG. 6

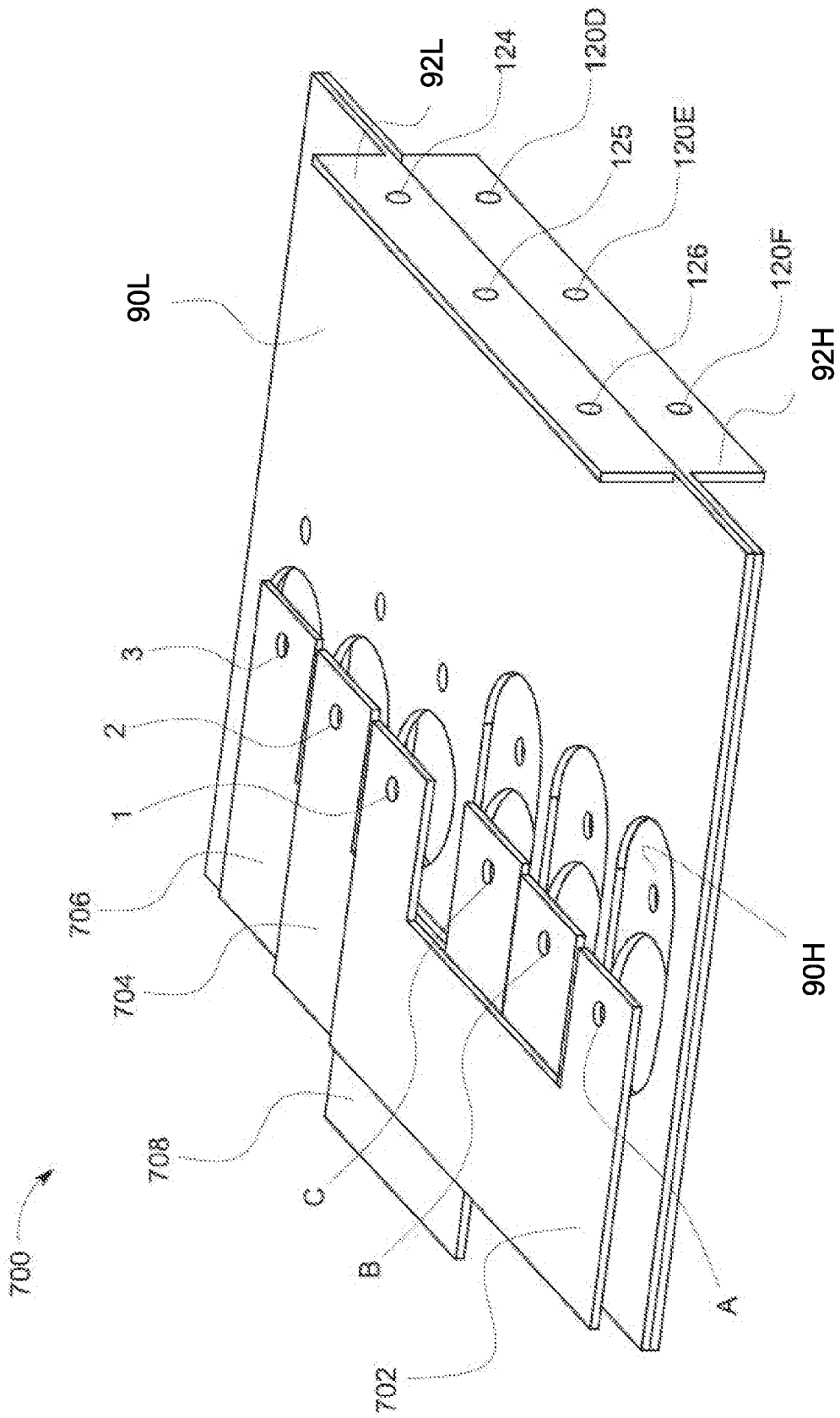

FIG. 7

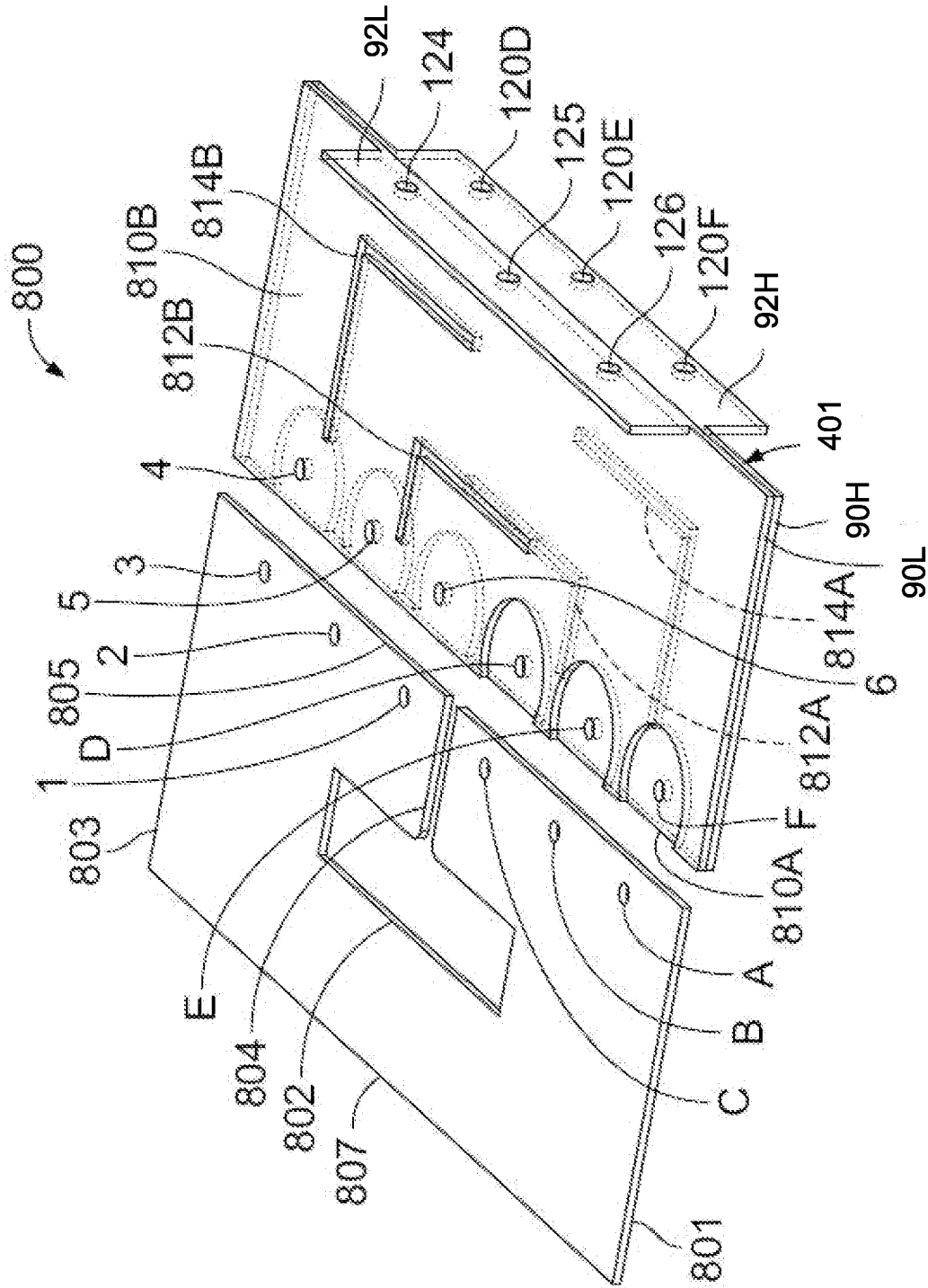

FIG. 8



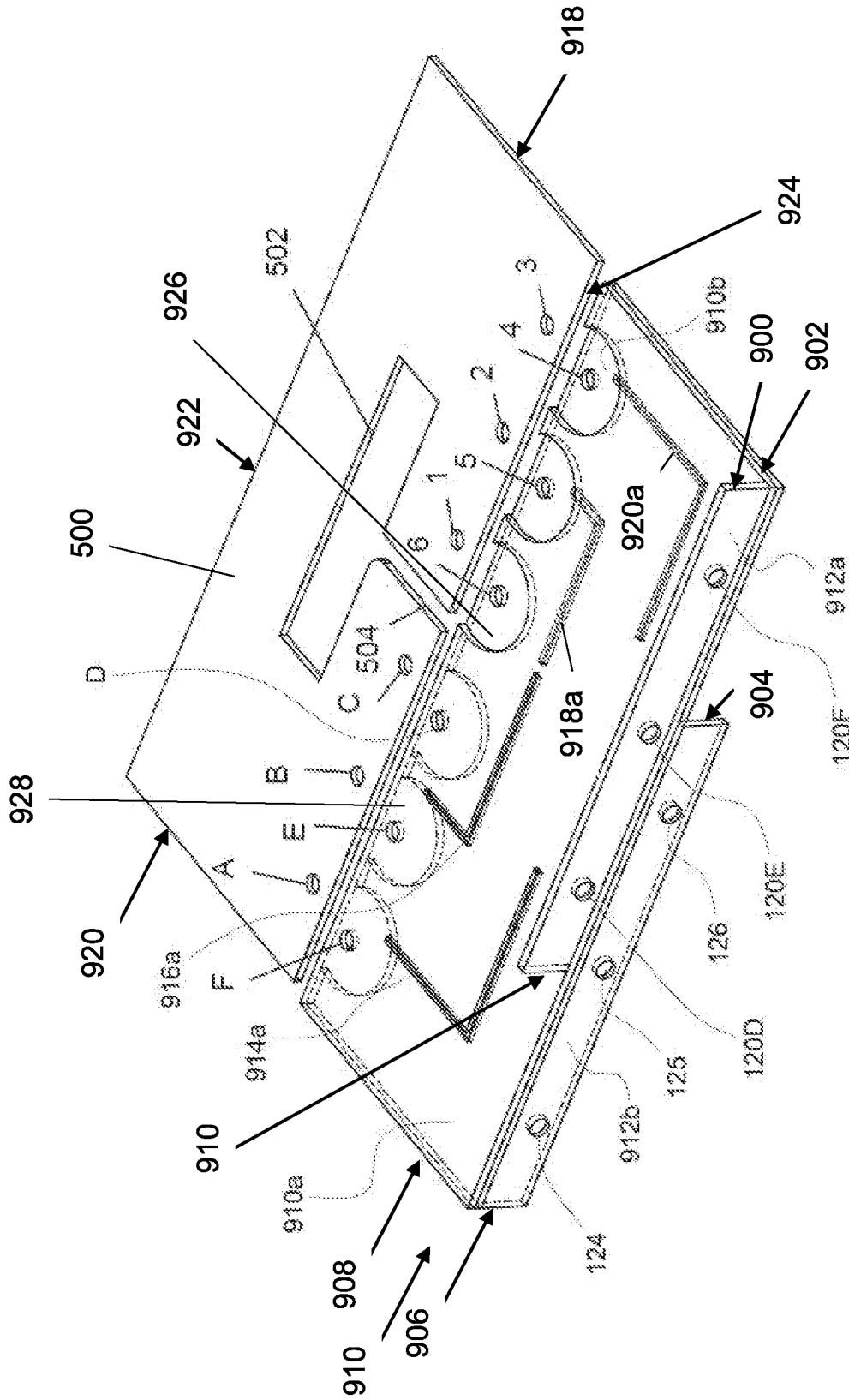

FIG. 9

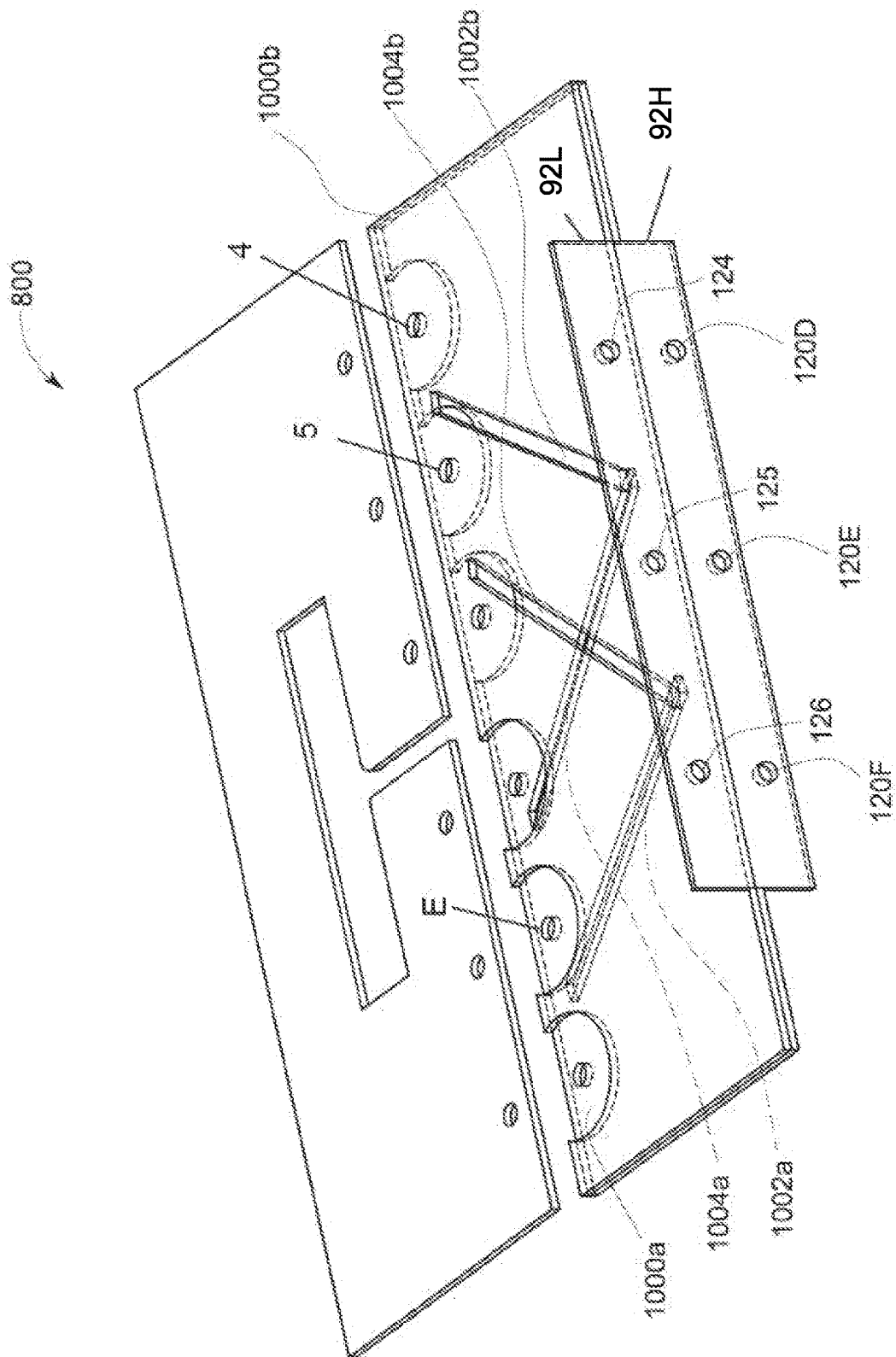

FIG. 10

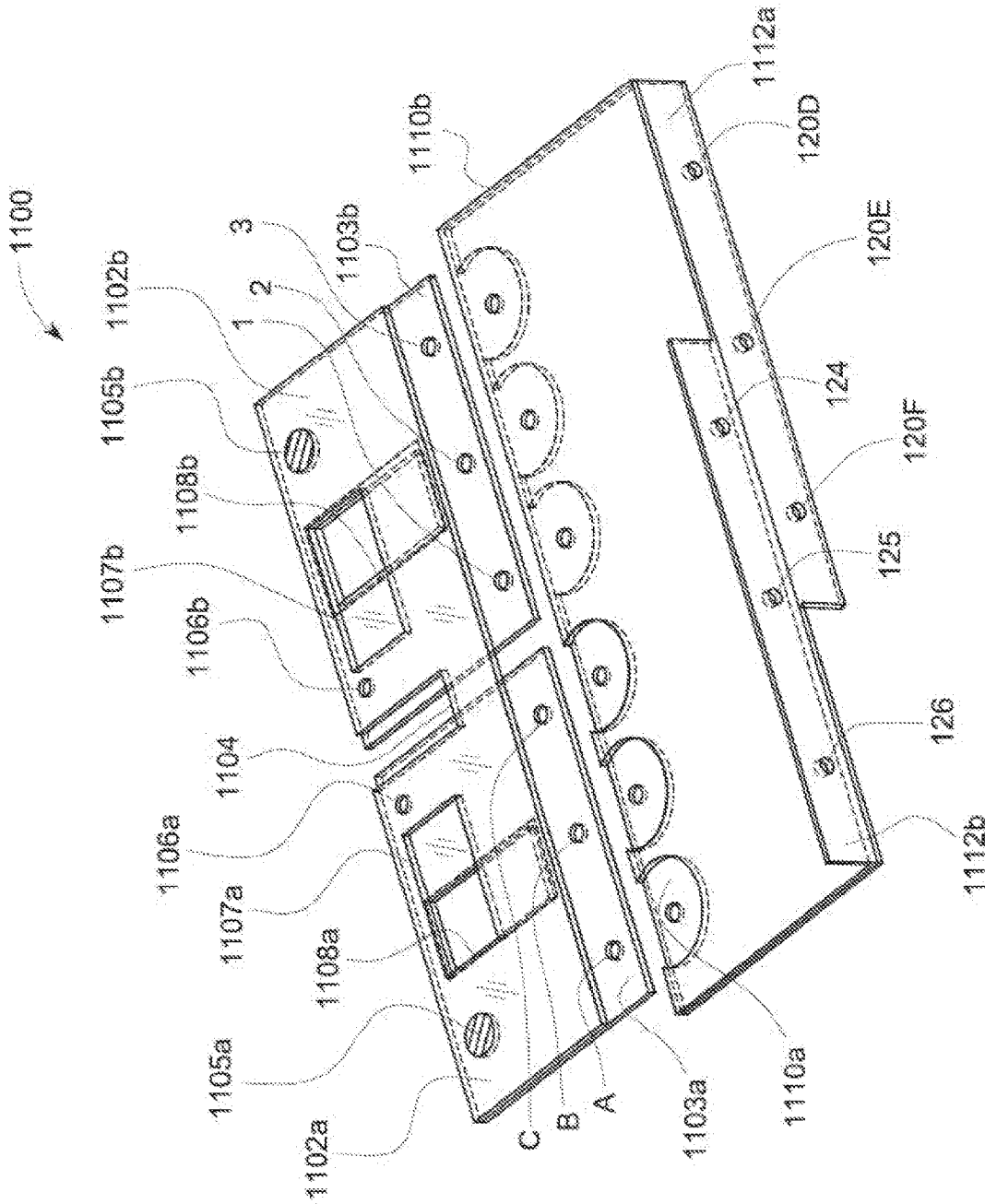

FIG. 11

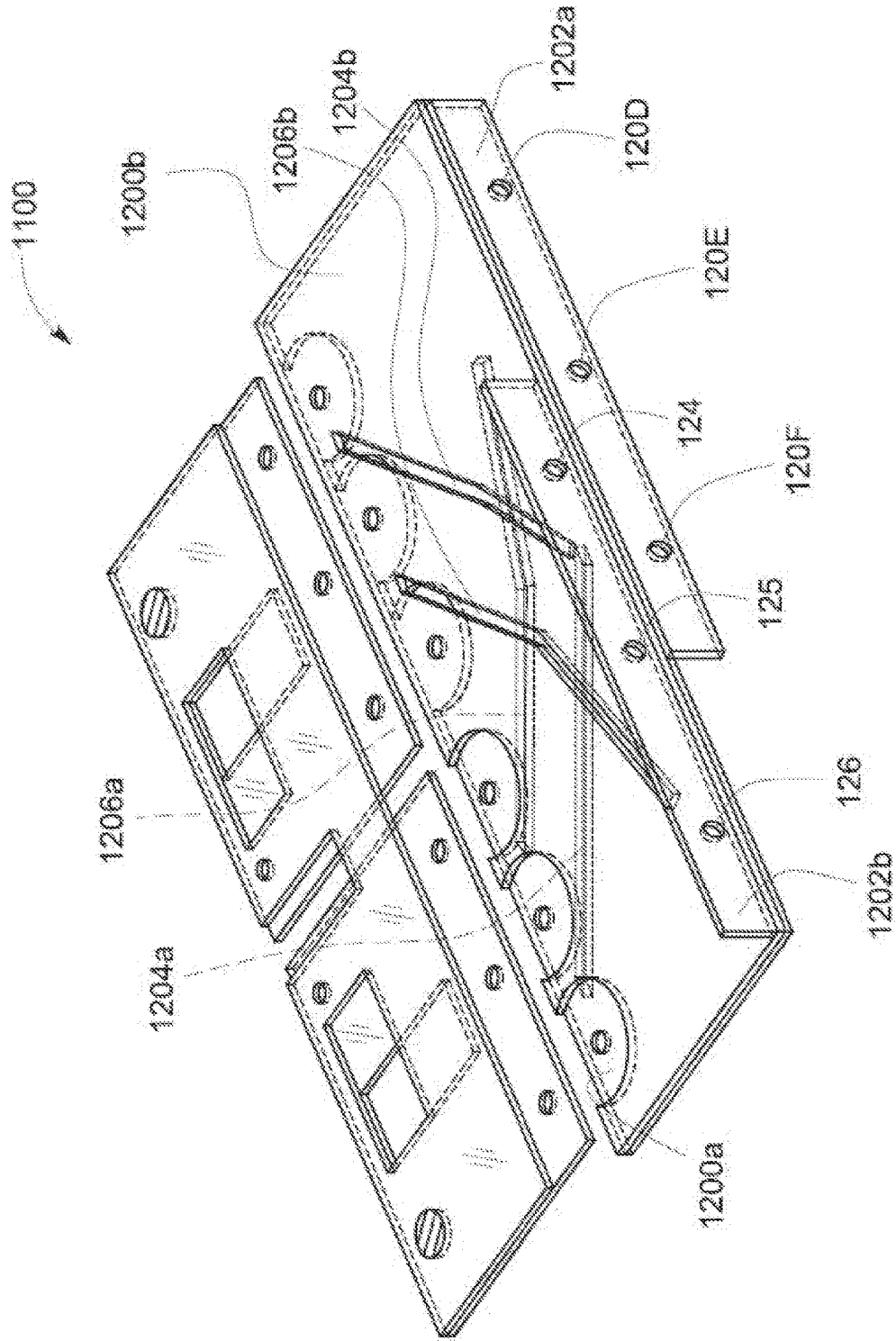

FIG. 12

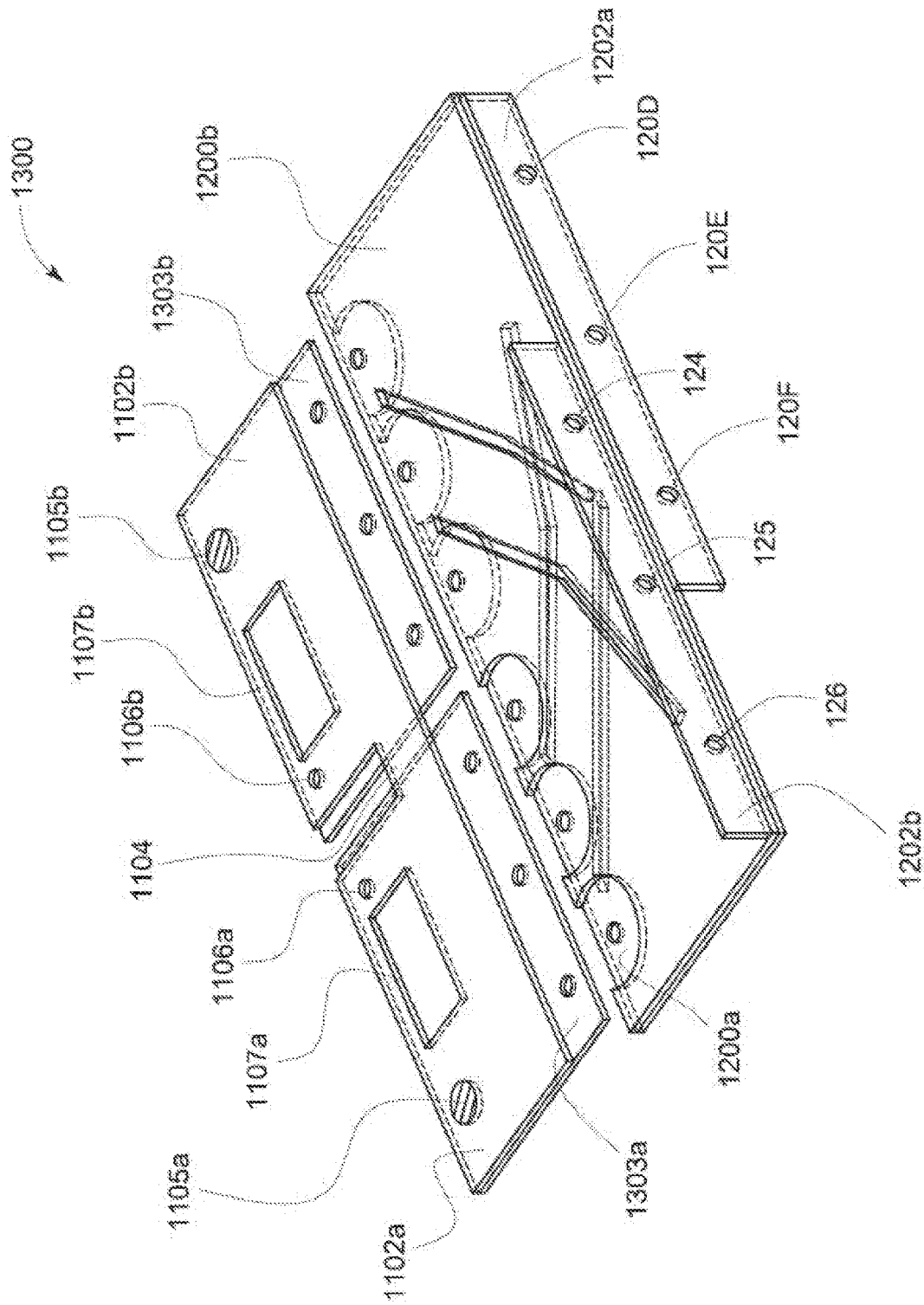

FIG. 13



**BUS BAR AND POWER ELECTRONIC  
DEVICE WITH CURRENT SHAPING  
TERMINAL CONNECTOR AND METHOD OF  
MAKING A TERMINAL CONNECTOR**

**CROSS-REFERENCE TO RELATED  
APPLICATIONS**

[0001] This application is a continuation-in-part of and claims priority to U.S. patent application Ser. No. 16/874,346 (filed 14 May 2020), which is a continuation-in-part and claims priority to U.S. patent application Ser. No. 16/149,946 (filed 2 Oct. 2018, now U.S. Pat. No. 10,693,265), which is a divisional of and claims priority to U.S. patent application Ser. No. 15/524,288 (filed 4 May 2017, now U.S. Pat. No. 10,128,625), which is a national stage entry of and claims priority to International Patent Application No. PCT/US2015/061217 (filed 18 Nov. 2015), which claims priority to U.S. Provisional Application No. 62/081,179 (filed 18 Nov. 2014). The entire disclosures of these applications are incorporated herein by reference.

**BACKGROUND**

**Technical Field**

[0002] Embodiments of the inventive subject matter relate generally to power electronics, e.g., switching devices. Particular embodiments relate to power electronic devices in which plural switching devices are packaged together.

**Discussion of Art**

[0003] Trains typically feature a number of cars that are pushed or pulled by a locomotive. The locomotive has traction wheels engaged with the track. In modern designs, electric wheel motors drive the traction wheels. The electric wheel motors are powered via electrical distribution from one or more engine-driven generators housed within the locomotive. The traction wheels and wheel motors can be reversibly configured, to also act as brakes for slowing the locomotive.

[0004] Similarly, in the mining industry, large off-highway vehicles (“OHVs”) usually employ electrically motorized wheels for propelling or retarding the vehicle. In particular, OHVs typically include a large horsepower diesel engine in conjunction with an alternator, a main traction inverter, and a pair of wheel drive assemblies housed within the rear tires of the vehicle. The diesel engine is directly associated with the alternator such that the diesel engine drives the alternator. The alternator powers the main traction inverter, in which semiconductor power switches commutate the alternator output current to provide electrical power to electric drive motors of the two wheel drive assemblies.

[0005] In both locomotive and OHV applications, solid-state power converters are used to provide high voltage current from the generators or alternators to the wheel motors. Such power converters include inductive coils to step down the voltage as well as semiconductor power switches to commutate the current. Although the above-described applications are typical, power converters can be used in other settings.

[0006] Generally, operation of a power converter is accomplished by applying alternately two different gate voltage levels to individual semiconductor power switches via corresponding gate drive units. Exemplary semiconduc-

tor power switches include IGBTs as well as BIGTs. Semiconductor power switches, however, are subject to cyclic thermal stresses. More specifically, while driven by a gate voltage, each power switch conducts significant current in a forward direction at a relatively small voltage drop across the switch. Despite the relatively low voltage across the forward-biased power switch, resistive heating nonetheless occurs. When gate voltage is removed, each semiconductor ceases to conduct (except for leakage current). Thus, with proper thermal design, a power switch not driven by gate voltage should cool toward ambient temperature.

[0007] Although durability is a consideration in semiconductor design, electrical design constraints entail that the various layers of the semiconductor power switches are fabricated from materials having differing thermal properties; in particular, differing coefficients of thermal expansion. As a result, over time, thermal stress can potentially cause delamination, debonding of terminals, or fatigue cracking. Thermal stress can also cause electrochemical failures such as current filamenting and Kirkendall void formation.

[0008] Thermal stress effects can be rendered more predictable, and can be mitigated, by maintaining the heating/cooling cycle within a design envelope defined to minimize temperature swings despite continual on/off cycling. For example, semiconductor power switches may be specially packaged with reference to a heat sink or coolant conduit, such that all of the power switches mounted on the heat sink are at a generally common temperature. Such switches are commonly referred to as “isothermal switches.”

[0009] Structural configurations of isothermal switches, however, may present challenges in electrical circuit balancing. For example, switch electrical connection points are split into multiple terminals to allow high currents. Terminal connectors are then used to provide a common electrical connection of the multiple terminals. Typically, a terminal connector includes a conductive layer sandwiched between insulative layers. The terminal connector is connected to the multiple terminals most often by screws, although other fastening methods may be used. While such packaging arrangements often provide operational benefits with isothermal switches, they may present challenges in keeping the circuit “electrically balanced” such that all electrical terminals belonging to the same electric point see the same current flow and hence the same power losses. Electrically unbalanced systems (those where electrical terminals belonging to the same electric point do not see the same current flow and power losses) may show undesirable electric behaviors in the circuit, since the switching devices will be at different operating points far from the ones foreseen by design and not balanced.

[0010] In view of the above, it may be desirable to optimize both electrical and thermal parameters of semiconductor switches in a power converter in order to control resistance and keep stray inductance values as low as possible.

**BRIEF DESCRIPTION**

[0011] In one embodiment, a bus bar includes a load terminal connector comprising a conductive plate that extends from a first edge to an opposite second edge and extends from a third edge to an opposite fourth edge. The third and fourth edges extend from the first edge to the second edge. The plate includes a window opening located

between the first and second edges and between the third and fourth edges. The plate also includes a slot extending into the plate from the first edge to the window opening. The plate includes first and second sets of openings configured to receive connections with first and second power terminals of switch packages. The first set of openings and the second set of openings are located on opposite sides of the slot.

**[0012]** In one embodiment, a bus bar includes a supply terminal connector including a first planar conductive plate and a first tab that protrudes from the first planar conductive plate. The first planar conductive plate includes a first set of openings configured to receive connections with first power terminals of switch packages. The first tab includes a second set of openings configured to receive connections with a direct current (DC) bus of a DC link. The first planar conductive plate includes L-slots extending through the first planar conductive plate between the first tab and the first set of openings in the first planar conductive plate.

**[0013]** In one embodiment, a bus bar includes a load terminal connector formed from a first conductive plate that extends from a first edge to an opposite second edge and extends from a third edge to an opposite fourth edge. The third and fourth edges extend from the first edge to the second edge, the load terminal connector including a window opening located between the first and second edges and between the third and fourth edges. The plate also includes a slot extending into the plate from the first edge to the window opening. The load terminal connector also includes first and second sets of openings configured to receive connections with first and second power terminals of switch packages. The first set of openings and the second set of openings are located on opposite sides of the slot. The bus bar also includes a supply terminal connector including a second conductive plate and a first tab that protrudes from the second conductive plate. The second conductive plate includes a third set of openings configured to receive connections with the first power terminals of the switch packages. The first tab includes a fourth set of openings configured to receive connections with a direct current (DC) bus of a DC link.

#### DRAWINGS

**[0014]** The inventive subject matter will be better understood from reading the following description of non-limiting embodiments, with reference to the attached drawings, wherein below:

**[0015]** FIGS. 1 and 2 illustrate examples of power converters for traction applications;

**[0016]** FIG. 3 illustrates one example of a phase leg of a power converter mounted on a heat sink;

**[0017]** FIG. 4 illustrates one example of a bus bar comprised of three terminal connectors for connection to the phase leg shown in FIG. 3;

**[0018]** FIG. 5 illustrates one example of a load terminal connector;

**[0019]** FIG. 6 illustrates one example of a matrix used in developing one or more embodiments of the inventive subject matter described herein;

**[0020]** FIG. 7 illustrates one example of a bus bar;

**[0021]** FIG. 8 illustrates another example of a bus bar;

**[0022]** FIG. 9 illustrates another example of a bus bar;

**[0023]** FIG. 10 illustrates another example of a bus bar;

**[0024]** FIG. 11 illustrates another example of a bus bar;

**[0025]** FIG. 12 illustrates another example of a bus bar;

**[0026]** FIG. 13 illustrates another example of a bus bar; and

**[0027]** FIG. 14 illustrates another example of a bus bar.

#### DETAILED DESCRIPTION

**[0028]** Reference will be made below in detail to example embodiments of the inventive subject matter, examples of which are illustrated in the accompanying drawings. Whenever possible, the same reference characters used throughout the drawings refer to the same or like parts, without duplicative description. Although example embodiments of the inventive subject matter are described with respect to traction power converters, embodiments of the inventive subject matter also are applicable generally for use in any system that commutates an output with the poles of a direct current (DC) power supply.

**[0029]** FIG. 1 illustrates one example of a power converter 10 for traction applications. The power converter 10 includes phase legs 20 that are connected between a DC link 30 and phase windings 40. The phase windings may be windings of a traction motor or a transformer, as a couple of examples. Each phase leg 20 includes a pair of “switch packages” (power electronic devices) 60H, 60L. One of the switch packages can include a high-potential switch package 60H that is connected from a high voltage bus 30H of the DC link 30 to a terminal of one of the phase windings 40. Another switch package can include a low-potential switch package 60L that is connected from the same terminal of the same phase winding 40 to a low potential bus 30L of the DC link 30. Thus, each phase winding 40 is connected between two phase legs 20 comprising four switch packages 60. In operation, the switch packages 60 commutate the phase winding 40 with the DC link buses 30H, 30L so as to produce an alternating current through the phase winding.

**[0030]** As shown schematically in FIG. 2, a switch package 60H, 60L includes a switch element 70H, 70L (e.g. MOSFET, IGBT, BJT, SiC transistor, or another semiconductor transistor or other semiconductor switch), respectively, as well as a flyback or freewheel element 80H, 80L (e.g., a diode connected anti-parallel to the switch element). The switch element and the freewheel element can be combined into a single semiconductor structure, e.g. a BIGT. As shown in FIG. 2, each switch element 70H, 70L is supplied with gate voltage from a controller via a gate lead 71H, 71L. In IGBTs as shown, application of gate voltage at the gate lead enables current to flow from collector terminals 72H, 72L through the switch element to emitter terminals 73H, 73L. The high potential switch element 70H has supply terminals (e.g., high potential collector terminal(s) 72H) that are connected by a first supply terminal connector 90H to the DC link high voltage bus 30H. The high potential switch element 70H also has load terminals (e.g., high potential emitter terminal(s) 73H) that are connected by a load terminal connector 100 to the terminal(s) of the phase winding 40 and to load terminals (low potential collector terminals 72L) of the low potential switch element 70L. The low potential switch element 70L has supply terminals (low potential emitter terminals 73L) that are connected to the DC link low voltage bus 30L by a second supply terminal connector 90L. Optionally, the emitter terminals may be drain terminals of a field effect transistor (FET) and the collector terminals may be source terminals of an FET. The



connectors shown and described herein may be planar conductive bodies (e.g., plates) or may have another shape (e.g., not a planar shape).

**[0031]** Together, the terminal connectors form a phase leg bus bar that connects the switch elements **70H**, **70L** of the phase leg **20** to the DC links and to the phase winding **40**. The supply terminal connectors **90H**, **90L** and the load terminal connector **100** are insulated from each other. For example, the bus bar may be a laminate assembly that includes plural conductive layers with intervening insulative layers.

**[0032]** During normal operation of a power converter **10**, the switch elements **70H**, **70L** of each phase leg **20** are controlled to commutate the DC link high and low buses **30H**, **30L** with the respective load terminal connector **100**, and the commutations of the several phase legs **20** are timed to establish alternating current flow within the phase windings **40** that are connected between the several load terminal connectors **100**. The switch elements often are thermally and electrically anisotropic. For example, not all of the collector terminal(s) and emitter terminal(s) may be exposed to the same temperature environment as each other. Lack of isotropy among the switch element terminals can lead to non-uniform electrical conditions within the switch elements, which, in turn, can detract from switching performance. For example, certain transients during commutation of a phase leg **20** can induce an ephemeral current from the DC link high voltage bus, through the switch elements and the terminal connector, to the DC link low voltage bus. This ephemeral current imposes resistive, inductive, and capacitive losses within the terminal connectors.

**[0033]** The high potential and low potential switch packages can be arranged on a heat sink **110**, as shown in FIG. **3**, such that the load terminals (e.g., the terminals connected to a motor or other load, such as the emitter terminals **73H-1**, **73H-2**, **73H-3** and the collector terminals **72L-1**, **72L-2**, **72L-3**) are adjacent or near a coolant inlet side **112**. This can allow for coolant flow to maintain the load terminals at a first substantially same phase terminal temperature. The supply terminals (e.g., the terminals connected to the DC bus, such as collector terminals **72H-4**, **72H-5**, **72H-6** and the emitter terminals **73L-4**, **73L-5**, **73L-6**) are adjacent or near a coolant outlet side having outlets **114**. The coolant flow can maintain the supply terminals at a second substantially same bus terminal temperature, which is slightly higher than the phase terminal temperature.

**[0034]** With reference to FIG. **4**, in an embodiment, a phase leg bus bar **400** includes conductive plates overlaid on an insulative substrate with intervening insulative layers. The insulative layers can be fabricated from materials that have a high dielectric breakdown voltage, are inexpensive, are easy to adhere using an adhesive, are resistant to abrasion and accidental scratches, do not deteriorate with temperature and ultraviolet radiation, and thereby achieve a long life. Example materials include thin film polyesters (e.g., mylar, tedlar, kapton), cellular silicone foams, and celled polyurethane foams. The thickness of each insulative layer can depend on system parameters such as, for example, the insulation voltage class, anticipated operating temperatures, and desirable partial discharge level. For example, a typical insulative layer may incorporate between about 300-500  $\mu\text{m}$  insulation.

**[0035]** The conductive plates provide a DC+ supply terminal connector **90H**, a DC- supply terminal connector **90b**,

and a load terminal connector **100**. Each conductive plate may be full rectangular in shape and is continuous in structure, with minimal or reduced features to permit electrical and/or mechanical connections through the insulative layer(s) and/or through other plates to the underlying semiconductor power switch. For example, the DC- supply terminal connector **90b** has a tab **92L** with pre-defined locations (e.g., holes) **124**, **125**, **126** for connecting to the DC low voltage bus **30L**, and at the other edge, has pre-defined locations (e.g., holes) **4**, **5**, **6** for connecting to emitter terminals **73L-4**, **73L-5**, **73L-6**, respectively.

**[0036]** The DC+ supply terminal connector **90H** has a tab **92H** with pre-defined locations (e.g., holes) **120D**, **120E**, **120F** for connecting to the DC high voltage bus **30H**, and at the other edge, has pre-defined locations (e.g., holes) **D**, **E**, **F** for connecting to collector terminals **72H-4**, **72H-5**, **72H-6**. The load terminal connector **100** has a first plurality of pre-defined locations (e.g., holes) **A**, **B**, **C** for connecting respectively to the emitter terminals **73H-1**, **73H-2**, **73H-3** and has a second plurality of pre-defined locations (e.g., holes) **1**, **2**, **3** for connecting respectively to the collector terminals **73L-1**, **73L-2**, **73L-3**. Each of the plates also has larger clearance holes **122** for access to the pre-defined locations of the other plates. The terminal connector **100**, DC- supply terminal connector **90L**, and DC+ supply terminal connector **90H** are electrically insulated from one another by intervening insulative layers **401**, such that tab **92H** and tab **92L** are not electrically connected to one another with the insulative layer **401** disposed between the tabs **92H**, **92L**. The insulative layer **402** is shown as a thin line between the tabs **92H**, **92L** in FIG. **4**, but alternatively may have a greater thickness.

**[0037]** With respect to material usage, the phase leg bus bar **400** as shown in FIG. **4** may be inefficient. For example, current may not be conducted or flow in the portion of the load terminal connector **100** between the tabs **92H**, **92L** and the holes **122**, nor in the portions of the supply terminal connectors distal from the tabs **92H**, **92L** beyond the holes **120**. To the extent that current occurs in these dead plate regions, the current is more likely to be eddy current that is induced by electron flow in adjacent plates. The phase leg bus bar **400** may also be relatively electrically inefficient. For example, during commutation transients, the ephemeral current flows or is conducted predominantly among the four inner terminals **1**, **6**, **C**, **D**, somewhat among the next inner terminals **2**, **5**, **B**, **E**, and negligibly among the four outer terminals **3**, **4**, **A**, **F**. The non-uniform current distribution produces uneven heating by inductive and resistive losses, which, in turn, exacerbates the discrepancies in resistance among the various conductive pathways so that current crowding may emerge among the innermost terminals.

**[0038]** Accordingly, embodiments of the inventive subject matter seek to reduce material waste by re-shaping the supply terminal connectors **90H**, **90L** and/or the load terminal connector **100** to balance impedances and optimize mutual inductances among the respective terminals (**1**, **2**, **3**, **A**, **B**, **C** of the load terminal connector **100**; **4**, **5**, **6**, **124**, **125**, **126** of the DC- supply terminal connector **90L**; **D**, **E**, **F**, **120D**, **120E**, **120F** of the DC+ supply terminal connector **90H**). With reference to FIGS. **5-14**, other aspects of the inventive subject matter relate to modifying shapes of supply terminal connectors and load terminal connectors to provide bus bars with discrete or substantially discrete current paths between selected pairs of terminals. For

example, in certain embodiments, a bus bar (e.g., phase leg bus bar) includes an even number of laminations at each set of switch terminals. The use of paired laminations arises from an observation that currents follow the lowest impedance paths and influence the stray inductance behavior according to their layout. If adjacent currents are oppositely directed by the conductive geometry, favorable mutual inductance contributes to cancelling overall stray magnetic fields and diminishing inductive losses.

**[0039]** In embodiments, for all terminals connecting to a same voltage source, each terminal may be connected in a current path of the same impedance, sum of the contribution of the resistance and the inductance, including AC effects like proximity. Generally, embodiments of the inventive subject matter provide that switch terminals are substantially electrically and thermally balanced in load. For example, all switch terminals see substantially the same current flow and substantially the same thermal environment, and, therefore, exhibit substantially the same power losses.

**[0040]** Therefore, bus bars according to embodiments of the inventive subject matter (e.g., phase leg bus bars) can mitigate losses imposed by the ephemeral current under design current injection transient conditions, thereby reducing switching heat loss. Additionally, by substantially balancing the currents among the terminals, switch response time and uniformity may be improved, e.g., eliminating or substantially eliminating current loops among switch terminals.

**[0041]** Thus, according to aspects of the inventive subject matter, smart shaping of supply terminal connectors and load terminal connectors assures that during a design commutation transient the ephemeral current within a phase leg bus bar is substantially balanced between corresponding terminals and is directed in such a way that negative mutual inductance is maximized, that is, stray magnetic fields are minimized. Additionally, switch response is improved by establishing substantially the same electrical and/or thermal conditions at each terminal of a switch.

**[0042]** In this regard, FIG. 5 shows an example terminal connector 500 that includes a gap formed, in this example, by a window 502 and a slot 504. to the gap can be, for example, a window, slot, layer separation, region of reduced material thickness, or other structure, along or in combination, that presents significantly higher resistance than surrounding structure. Significantly higher resistance can be a difference in conductivity that is sufficiently large such that all or substantially all current avoids the gap structure.

**[0043]** Referring to FIG. 5, the terminal connector 500 is marked with indicia corresponding to its various terminals and conductive pathways among those terminals, while FIG. 6 shows a matrix of mutual resistances and inductances among the terminals labeled according to the indicia shown in FIG. 5. The indicia A, B, C correspond to a plurality of first pre-defined locations on the terminal connector 500, while the indicia 1, 2, 3 correspond to a plurality of second pre-defined locations on the terminal connector 500. The window 502 and the slot 504 separate the first pre-defined locations from the second pre-defined locations, and constrain current flow among the pluralities of pre-defined locations such that each of the pre-defined locations is substantially electrically balanced with each other of the pre-defined locations.

**[0044]** As used herein, the terms “substantially,” “generally,” and “about” indicate conditions within reasonably

achievable manufacturing and assembly tolerances, relative to ideal desired conditions suitable for achieving the functional purpose of a component or assembly. “Substantially balanced” or “substantially electrically balanced” specifically refers to a condition in which electrical and/or thermal values among a plurality of conductive paths, between common terminals, remain within plus or minus 10% variation. “Balanced,” on the other hand, implies a narrower range of plus or minus 3% variation.

**[0045]** Referring specifically to thermal variations, as used herein, a set of terminals of a power electronic device mounted on a heat sink may be described as “substantially thermally equidistant” with each other from the coolant, wherein all of the set of terminals have about the same temperature difference (plus or minus 10%) from the coolant inlet temperature during operation. Moreover, they may be described as “thermally equidistant” from the coolant in case all of the set of terminals have the same temperature difference (plus or minus 3%) from the coolant inlet temperature. On the other hand, the terminals may be described as “substantially thermally balanced” with each other in embodiments where each of the terminals exhibits substantially a same thermal power dissipation (plus or minus 10%) as each other of the terminals, and may be described as “thermally balanced” with each other in embodiments where each of the terminals exhibits a same thermal power dissipation (plus or minus 3%) as each other of the terminals.

**[0046]** Similarly, the terminals may be described as substantially electrically balanced in embodiments where each of the terminals carries substantially (plus or minus 10%) a same current as each other of the terminals, or electrically balanced in case each of the terminals carries a same current, plus or minus 3%, as each other of the terminals.

**[0047]** By defining the current pathways between among the plural terminals, resistance and inductance circuit parameters can be controlled to convenient values that provide electrical balance across the terminal connectors among the terminals. In embodiments, current paths are shaped, especially during commutation transients, so that switching device terminals are electrically and thermally balanced.

**[0048]** It will be understood that aspects of the inventive subject matter involve impedance matching and operating power dissipation, so that a particular arrangement of terminals or of conductive pathways may be described as balanced or substantially balanced with reference to a particular designed range of operating parameters. Similarly, a particular arrangement of electrical terminals may be described as thermally equidistant or substantially thermally equidistant from a reference substance (e.g., coolant) or location, with reference to the same particular designed range of operating parameters.

**[0049]** For example, under certain operating parameters by which one of a pair of power electronic devices sees a significantly higher duty cycle than the other of the pair of power electronic devices, then a particular layout of those power electronic devices on a heat sink might be required in order to render bus terminals of the high-duty-cycle device and of the low-duty-cycle device thermally equidistant from the coolant in the heat sink.

**[0050]** Turning now to the matrix depicted in FIG. 6, the values of resistance and inductance are calculated based on a design commutation transient, in light of such parameters as switching frequency, pulse duration, gate voltage ramp

rate, and plate dimensions. Certain parameters are designated as fixed parameters (e.g., switching frequency, pulse duration) while others (e.g., turn on/turn off current and/or voltage ramps, plate dimensions, presence or absence of windows in plates) may be designated as variant parameters. Although skin effect is not a concern during steady state operation, for high-frequency transients it may be considered.

[0051] To converge to an acceptable set of design candidates (a set of candidates in which each candidate provides for substantial electrical and thermal balance among pre-defined locations), the resistance and inductance matrices are normalized, and the variant parameters are repeatedly varied to obtain a plurality of candidate configurations. In an embodiment, for each candidate configuration, a Euclidean norm is calculated. For example, for the matrix of inductances, a norm is calculated according to the formula

$$\|\Delta L\|_p = \left( \sum |\Delta L_{ij}|^p \right)^{1/p}.$$

[0052] The candidate matrix with lowest Euclidean norm then is selected as the closest to a balanced situation. This design approach can be automated and iterated using, e.g., a genetic algorithm, in order to obtain a “current shaping” terminal connector in which the gap or gaps are shaped to obtain substantially balanced electrical and thermal conditions.

[0053] FIG. 7 illustrates an embodiment of a bus bar that includes a load terminal connector 700 that overlaps the supply terminal connectors 90H, 90L, which are provided for connection to a DC link. The load terminal connector is a current shaping terminal connector, comprised of wing layers 702, 706 and a central layer 704 that is sandwiched between the wing layers. The left or upper wing layer 702 includes holes A and 1 for connection to terminals 73H-1 and 73L-1 as shown in FIG. 3. The central layer 704 includes holes B and 2 for connection to terminals 73H-2 and 73L-2 shown in FIG. 3. The lower or right wing layer 706 includes holes C and 3 for connection to terminals 73H-3 and 73L-3 as shown in FIG. 3. The three layers 702, 704, 706 provide discrete conductive pathways among pairs of the terminals A, B, C, 1, 2, 3, such that each of the pathways is of substantially equal impedance to the others. Presuming substantially identical voltage transients across each of the paired terminals, then substantially equal currents will flow through each of the terminals A, B, C or 1, 2, 3 along the three discrete conductive pathways.

[0054] The three layers 702, 704, 706 may provide discrete and substantially balanced conductive pathways amongst the one or more pre-defined first locations A, B, C and the plurality of pre-defined second locations 1, 2, 3. All three layers of the load terminal connector 700 may at least partially overlap to form a projecting tab 708. This tab can include pre-defined load locations for connection of load leads to a winding or other load. Such a projecting tab may be provided at various locations on a load terminal connector, and may be provided in each embodiment of the bus bar as shown in the various figures herein. On the other hand, certain embodiments may have load leads directly connected at the plane of a load terminal connector, without a projecting tab.

[0055] During commutation transients, a magnetic field induced from the ephemeral current through the upper wing layer 702 partially cancels magnetic fields induced from the ephemeral current through the central layer 704 and the lower wing layer 706. At all times, the provision of discrete layers for each pair of terminals, all three of the discrete layers having conductive paths of substantially equal length, enhances conduction and reduces resistive losses within the load terminal connector 700. Collectively, the three layers 702, 704, 706 provide substantially balanced conductive paths among the six terminals A, B, C, 1, 2, 3.

[0056] According to an aspect, the wing layers and/or the central layer may be generally elongated U-shaped, with the layer comprising a conductive sheet (e.g., metal sheet) having a main portion with first and second ends, a first tab or wing protruding from the main portion at the first end, and a second tab or wing protruding from the second end. The first and second tabs include respective locations (e.g., holes) for attachment of a device or devices. The tabs protrude in a common direction, such that in a straight line between the locations (e.g., holes) on the tabs, there is an area where there is no conductive material of the sheet, or at least there is a gap such that no or substantially no current can flow in a straight line directly between the locations (e.g., holes).

[0057] FIG. 8 illustrates a second embodiment of a bus bar, which includes a load terminal connector 800 in combination with supply terminal connectors 810a, 810b. The load terminal connector 800 does not overlap the supply terminal connectors 810a, 810b. Instead, the load terminal connector 800 may be disposed to one side of the supply terminal connectors 810a, 810b. The load terminal connector 800 is formed as a planar and conductive phase plate that extends from one edge 801 to an opposite edge 803, and from a facing edge 805 to an opposite edge 807. The edges 801, 803 connect the edges 805, 807 with each other.

[0058] The plate of the connector 800 includes a central opening or window 802 from which a slot 804 extends to the facing edge 805 of the phase plate (e.g., the edge that faces the supply terminal connectors). For example, the slot 804 can extend into the body of the plate of the connector 800 from the edge 805 to a larger window 802. The slot 804 divides the edge 805 into two parts or halves that are separated from each other by the slot 804. The window 802 can extend closer to the edges 801, 803, 807 than the slot 804.

[0059] The window 802 and the slot 804 divide one or more pre-defined first locations (holes) A, B, C from pre-defined second locations 1, 2, 3. The first locations A, B, C can be used for connections or connectors (e.g., by conductive pathways, such as wires, buses, cables, or the like) with the higher potential switch package emitter terminals 73a. The second locations 1, 2, 3 can be used for connections or connectors (e.g., by conductive pathways, such as wires, buses, cables, or the like) with the lower potential switch package collector terminals 73L.

[0060] The window 802 and the slot 804 are arranged to optimize the mutual resistance and inductance as described by the matrix equations shown in FIG. 6. In particular, the window and slot provide substantially balanced conductive paths among the first locations A, B, C and the second locations 1, 2, 3 such that substantially equal first currents

flow through each of the first locations A, B, C and substantially equal second currents flow through each of the second locations 1, 2, 3.

[0061] Although equal numbers of first and second locations are shown (and, therefore, the magnitudes of the substantially equal first currents are substantially equal to the magnitudes of the substantially equal second currents), in other embodiments, a quantity of first locations may differ from a quantity of second locations. Stated differently, there may be fewer or more first locations than second locations. In such other embodiments, the shape of the load terminal connector 800 could be adjusted to provide for substantially equal first currents at each of the one or more first locations, and substantially equal second currents at each of the one or more second locations.

[0062] Still referring to FIG. 8, the supply terminal connectors 810a, 810b include planar conductive plates that include the tabs 92H, 92L that protrude out of the plane defined by the conductive plates. The tab 92H includes connector locations or openings 120D, 120E, 120F that can receive connections or connectors with THE tab 92L include locations or openings 124, 125, 126

[0063] L-slots 812a, 812b, 814a, 814b extend through the plates of the connectors 810a, 810b. The L-slots define substantially discrete and substantially balanced conductive paths from each one of the switch terminal connectors (first locations) D, E, F or 4, 5, 6 to a corresponding one of the tab holes (second locations) 120D, 120E, 120F or 124, 125, 126, respectively. The L-slots can be gaps or openings extending through one of the supply terminal connectors 810a or 810b, but not the other supply terminal connector 810b or 810a. For example, the L-slots 812a, 814a may extend through (form linear intersecting openings through) the supply terminal connector 810a but not extend through the supply terminal connector 810b. The L-slots 812b, 814b may extend through (form linear intersecting openings through) the supply terminal connector 810b but not extend through the supply terminal connector 810a. The L-slots 812, 814 create or lengthen the conductive pathways between each of the first locations and a corresponding second location to balance the impedances and optimize mutual inductances between the different pathways.

[0064] For example, the L-slot 814a separates two substantially discrete conductive paths: a path from one of the first locations (hole F) on supply terminal connector 810a, to one of the second locations (hole 120F) on tab 92H; and another path from another of the first locations (hole E) on supply terminal connector 810a, to another of the second locations (hole 120E) on tab 92H. These two substantially discrete conductive paths are substantially balanced with a third substantially discrete conductive path defined by the slot 816a from another of the first locations (hole D) to another of the second locations (hole 120D). Thus, substantially equal first currents are conducted through the first locations D, E, F and substantially equal second currents flow through the second locations 120D, 120E, 120F. (Each L-slot is a gap formed in the sheet of the connector 810a, 810b, which includes a first elongate gap portion with a first end and a second end, and a second elongate gap portion with a first end and a second end, the first end of the second elongate gap portion located at the second end of the first elongate gap portion and oriented perpendicular thereto. The elongate gap portions may have different lengths.)

[0065] Also, the two supply terminal connectors 810a, 810b are matching inverts of each other. For example, the plate 810a can be flipped over to become the plate 810b (and vice-versa). The two plates are overlaid adjacent an intervening insulative layer 401. The same is true for several other embodiments as described and illustrated following. Accordingly, in such embodiments the discrete conductive paths on the two supply terminal connectors generally are anti-parallel at their overlapping portions, e.g., during a commutation transient the current from hole 6 on plate 810b to hole 126 on tab 92L flows generally opposite direction to the current from hole D on plate 810a to hole 120D on tab 92H. Typically, these anti-parallel currents are substantially equal such that their mutual inductance cancels out.

[0066] The supply terminal connectors 810a, 810b and the load terminal connector 800 may be affixed to a common underlying planar insulative or other support, however, such a support is not shown in FIG. 8 for clarity of illustration.

[0067] FIG. 9 shows a third embodiment of a bus bar, which includes a similar load terminal connector 500 as shown in FIG. 5 in combination with a supply terminal connector assembly 910 having offset tabs 912a, 912b. The supply terminal connector assembly may be formed from supply terminal connectors 910a, 910b coupled or sandwiched on each other. The tabs can protrude from the supply terminal connector assemblies in directions that are opposite to each other (e.g., the tabs protrude in opposite directions) and/or in directions that are transverse (e.g., perpendicular or another angle) to the planes defined by the supply terminal connectors 910a, 910b.

[0068] These tabs are offset in that a lateral edge 900 of the tab 912a is disposed closer to one lateral side 902 of the supply terminal connectors than a lateral edge 904 of the tab 912b, an opposite lateral edge 906 of the tab 912b is disposed closer an opposite lateral side 908 of the supply terminal connectors than an opposite lateral edge 910 of the tab 912a, the lateral edge 910 of the tab 912a is between the lateral edges 904, 906 of the tab 912b, the lateral edge 900 of the tab 912a is not between the edges 904, 906 of the tab 912b, and/or the lateral edge 906 of the tab 912b is not between the edges 900, 910 of the tab 912a.

[0069] The load terminal connector 500 includes a central window 502 and an open slot 504, which together impose substantially balanced conductive pathways among the plurality of pre-defined first locations A, B, C and the plurality of pre-defined second locations 1, 2, 3. The window may be centered between opposite edges 918, 920 and between opposite edges 922, 924 of the terminal connector 500 or may be closer to one or more of these edges than another of these edges. The window can be formed as a hole or open volume that passes through the entirety of the terminal connector 500 in a location between the edges 918, 920 and between the edges 922, 924. The open slot can be a hole or open volume that passes through the entirety of the terminal connector 500 in a location between the edges 918, 920 and between the edges 922, 924. As shown, this slot can extend from the edge 924 of the terminal connector 500 to the window. Alternatively, the slot can extend from the edge 918, 920, or 922 to the window. Optionally, multiple slots may be provided. The slot has a linear shape in FIG. 9, but optionally may have a non-linear shape.

[0070] The supply terminal connectors 910a, 910b include L-slots 914a, 916a, 918a, 920a, etc. that define substantially discrete conductive paths among pairs of terminal connect-

ing holes (first locations D, E, F or 4, 5, 6 and second locations 120D, 120E, 120F or 124, 125, 126). For example, the L-slot 916a defines a substantially discrete conductive path from the hole (first location) D on supply terminal connector 910a to the hole (second location) 120D on offset tab 912a. The L-slots may extend through the entirety of the supply terminal connectors such that no part of either supply terminal connector is located within any of the L-slots. Alternatively, one or more of the L-slots may only extend through one, but not both, of the supply terminal connectors. Each L-slot may have a first leg 926 oriented parallel to the edges 902, 908 of the supply terminal connectors and a second leg 928 oriented parallel to the tabs. These first and second legs may intersect each other at right angles or another angle. As shown, the first leg of the L-slot 914a is disposed between the holes E, F; the first leg of the L-slot 916a is disposed between the holes D, E; the first leg of the L-slot 918a is disposed between the holes 4, 5; and the first leg of the L-slot 920a is disposed between the hole 4 and the edge 902 of the supply terminal connectors.

[0071] The supply terminal connector 910a may include circular or semi-circular holes 926, with each of these holes 926 extending around a different one of the holes 4, 5, 6. The supply terminal connector 910b may include circular or semi-circular holes 928, with each of these holes 928 extending around a different one of the holes D, E, F. The second legs of the L-slots 918a, 920a may extend to the holes 926 and the second legs of the L-slots 914a, 916a may extend to the holes 928. The intersection of the L-slots with these holes 926, 928 can define boundaries of the conductive pathways among pairs of terminal connecting holes (first locations D, E, F or 4, 5, 6 and second locations 120D, 120E, 120F or 124, 125, 126).

[0072] As in FIG. 8, the L-slots define discrete conductive paths on the two plates 910a, 910b that generally are anti-parallel at the overlapping portions. The offset tabs 912a, 912b enhance the opposition of the overlapping current paths across the plates 910a, 910b. Accordingly, in this and similar embodiments, the supply terminal connectors are arranged such that a magnetic field induced by current in a conductive pathway in one of the supply terminal connectors is substantially canceled (e.g., reduced to less than about 10% of what it otherwise would be) by a magnetic field induced by current in a corresponding conductive pathway in the other of the supply terminal connectors.

[0073] FIG. 10 shows a fourth embodiment of a bus bar, which includes the same load terminal connector 800 as shown in FIG. 8, in combination with supply terminal connectors 1000a, 1000b that have central tabs 92H, 92L and V-slots 1002a, 1002b, 1004a, 1004b. The V-slots 1002a, 1002b, 1004a, 1004b define substantially discrete conductive paths among pairs of first and second locations (terminal connecting holes), e.g., the V-slot 1002b defines a path from the hole 4 on supply terminal connector 1000b to the hole 124 on tab 92L. The discrete current paths generally are orthogonal at their overlapping portions, e.g., during a commutation transient the current from hole 5 on plate 1000b to hole 125 on tab 92L flows generally orthogonal to the current from hole E on plate 1000a to hole 120E on tab 92H.

[0074] FIG. 11 shows a fifth embodiment of a bus bar, which includes a load terminal connector 1100 that includes a windowed bridge plate with wings 1102a, 1102b, which is overlaid on windowed islands 1103a, 1103b. The wings

1102a, 1102b are connected via a bridge 1104. Thus, the bridge provides for current in the overlaid wings 1102a, 1102b to flow substantially opposite to current in the islands 1103a, 1103b, so that there are reversing conductive pathways in the overlaid layers. The load terminal connector 1100 is used in combination with a pair of supply terminal connectors 1110a, 1110b that have offset tabs 1112a, 1112b without any sort of slotting in the supply terminal connectors. Referring to the bridge plate, each wing 1102a or 1102b is connected to its underlying island 1103a or 1103b by vias or hot spots 1105a, 1105b, 1106a, 1106b pierced through an insulative layer (not shown). The hot spots 1105a, 1105b, 1106a, 1106b may be of differing size, and cooperate with the windows 1107a, 1107b in each wing 1102a, 1102b and the windows 1108a, 1108b in each island 1103a, 1103b in order to establish substantially anti-parallel current paths (reversing conductive pathways) of substantially equal resistance through the islands and their overlaying bridge wings. For example, a current path from hole A to hole 1 (through island 1103a, hot spots 1105a, 1106a, bridge wing 1102a, bridge 1104, bridge wing 1102b, hot spots 1106b, 1105b, and island 1103b) exhibits substantially the same resistance and inductance as a current path from hole 2 to hole B (through the same features). Meanwhile, during commutation transients the offset tabs 1112a, 1112b suffice to establish generally orthogonal paths for the ephemeral current through the supply terminal connectors 1110a, 1110b.

[0075] A sixth embodiment of a bus bar is shown in FIG. 12, wherein the load terminal connector 1100 is combined with supply terminal connectors 1200a, 1200b that incorporate offset tabs 1202a, 1202b along with W-slots 1204a, 1204b, 1206a, 1206b. The W-slots 1204a, 1204b, 1206a, 1206b define discrete conductive paths such that overlaying paths vary from substantially orthogonal near the holes F, E, D, 6, 5, 4 (not numbered in FIG. 12, but the same arrangement as in FIG. 9) to substantially anti-parallel near the tab holes 126, 125, 124, 120F, 120E, 120D.

[0076] FIG. 13 shows a seventh embodiment of a bus bar, in which a load terminal connector 1300 uses the windowed bridge plate 1102a, 1102b to connect non-windowed islands 1303a, 1303b. The load terminal connector 1300 is combined with supply terminal connectors 1200a, 1200b that have offset tabs 1202a, 1202b and W-slots 1204, 1206, substantially as shown in FIG. 12.

[0077] FIG. 14 shows an eighth embodiment of a bus bar, wherein the supply terminal connectors 1200a, 1200b are combined with a load terminal connector 1400 that uses doubly-windowed bridge wings 1402a, 1402b and a bridge 1404 to connect non-windowed islands 1303a, 1303b. In this case the windows 1407a, 1407b, 1408a, 1408b formed in the bridge wings 1402a, 1402b constrain the ephemeral current within the bridge wings to induce substantially anti-parallel current paths in the underlying islands 1303a, 1303b.

[0078] Thus, embodiments of the inventive subject matter provide a current shaping phase leg bus bar for power electronics systems, which includes a first terminal connector; a second terminal connector, insulated from the first terminal connector; and a third terminal connector, insulated from the first and second terminal connectors. At least one of the terminal connectors is a current shaping terminal connector that includes one or more layers having a plurality of pre-defined locations for electrical connections. The plurality of pre-defined locations include one or more first

locations and a plurality of second locations. The current shaping terminal connector also includes one or more gaps within or among its one or more layers, to provide substantially balanced conductive pathways among its one or more first locations and its plurality of second locations. In certain embodiments, at least two of the terminal connectors are current shaping terminal connectors that are configured to provide substantially balanced conductive pathways among their respective first locations and second locations. For example, two of the terminal connectors may be matching inverts of each other. In case two terminal connectors are matching inverts, they may be overlaid adjacent an intervening insulative layer. In certain embodiments, the terminal connectors are arranged such that a magnetic field induced by current in a conductive pathway in one of the at least two terminal connectors is substantially canceled by a magnetic field induced by current in a corresponding conductive pathway in the other of the at least two terminal connectors. In certain embodiments, the current shaping terminal connector comprises an even number of layers overlaid to provide reversing conductive pathways. For example, the current shaping terminal connector comprises a bridge layer overlaying and substantially insulated from an island layer, the bridge layer has lateral wings conductively joined by a central bridge, the island layer has lateral islands that are not conductively joined within the island layer, each lateral island of the island layer includes either at least one first location or at least one second location, and is conductively joined by at least one hot spot to an overlying lateral wing of the bridge layer, gaps are formed in the islands and wings to define substantially discrete conductive pathways from each of the one or more first locations to a corresponding one of the second locations, each of the substantially discrete conductive pathways includes the central bridge, and each of the substantially discrete conductive pathways includes a portion in the bridge layer that overlies in anti-parallel fashion a portion of that same conductive pathway in the island layer. In certain embodiments, the current shaping terminal connector includes at least one window. In certain embodiments, the current shaping terminal connector includes substantially discrete conductive pathways amongst the one or more first locations and the plurality of second locations. In certain embodiments, at least one of the gaps is a region of reduced material thickness.

**[0079]** Other embodiments provide a power electronic device, which has a heat sink that has a coolant inlet and a coolant outlet, first and second switch packages, each package having supply terminals and load terminals, the supply terminals of the first and second switch packages are substantially thermally equidistant from the coolant inlet at a first thermal distance and the load terminals of the first and second switch packages are substantially thermally equidistant from the coolant inlet at a second thermal distance that is less than the first thermal distance; and at least one current shaping terminal connector connecting the load terminals of the first and second switch packages, the current shaping terminal connector including one or more layers having a plurality of pre-defined locations for electrical connections, said plurality of pre-defined locations including one or more first locations and a plurality of second locations, and including one or more gaps within or among its one or more layers, to provide substantially balanced conductive pathways among its one or more first locations and its plurality of second locations. In certain embodiments, at least one of

the gaps is a region of reduced material thickness. In certain embodiments, the at least one current shaping terminal connector comprises an even number of layers overlaid to provide reversing conductive pathways. For example, the at least one current shaping terminal connector comprises a bridge layer overlaying and insulated from an island layer, the bridge layer has lateral wings conductively joined by a central bridge, the island layer has lateral islands that are not conductively joined within the island layer, each lateral island of the island layer includes either at least one first location or at least one second location, and is conductively joined by at least one hot spot to an overlying lateral wing of the bridge layer, gaps are formed in the islands and wings to define substantially discrete conductive pathways from each of the one or more first locations to a corresponding one of the second locations, each of the substantially discrete conductive pathways includes the central bridge, and each of the substantially discrete conductive pathways includes a portion in the bridge layer that overlies in anti-parallel fashion a portion of that same conductive pathway in the island layer. Each wing of the bridge layer, and/or each island of the island layer, may include at least one window. In certain embodiments, the at least one current shaping terminal connector includes substantially discrete conductive pathways amongst the one or more first locations and the plurality of second locations. In some embodiments, the at least one current shaping terminal connector has its first locations aligned substantially along a first line defined by the load terminals of the first switch package, and has its second locations aligned substantially along the same line connected with the load terminals of the second switch package, with the first locations of equal number as the second locations, and the at least one current shaping terminal connector includes gaps defining substantially discrete conductive paths connecting pairs of the first and second locations. In some embodiments, the power electronic device also includes second and third current shaping terminal connectors respectively connected to the supply terminals of the first switch package and to the supply terminals of the second switch package, and the second and third current shaping terminal connectors are matching inverts of each other. In such embodiments, the second and third current shaping terminal connectors may be arranged such that a magnetic field induced by current in a conductive pathway in one of the terminal connectors is substantially canceled by a magnetic field induced by current in a corresponding conductive pathway in the other of the terminal connectors.

**[0080]** Aspects of the inventive subject matter provide a method of making a current shaping terminal connector, which includes forming at least one conductive plate; forming on the at least one conductive plate a plurality of pre-defined locations, including at least one first location and a plurality of second locations; and forming in or about the conductive plate at least one gap that is configured to impose substantially balanced electrical pathways among the at least one first location and the plurality of second locations.

**[0081]** In one embodiment, a bus bar includes a load terminal connector comprising a conductive plate that extends from a first edge to an opposite second edge and extends from a third edge to an opposite fourth edge. The third and fourth edges extend from the first edge to the second edge. The plate includes a window opening located

between the first and second edges and between the third and fourth edges. The plate also includes a slot extending into the plate from the first edge to the window opening. The plate includes first and second sets of openings configured to receive connections with first and second power terminals of switch packages. The first set of openings and the second set of openings are located on opposite sides of the slot.

**[0082]** Optionally, the first set of openings is located in the plate between the third edge and the slot and the second set of openings is located in the plate between the fourth edge and the slot.

**[0083]** Optionally, the switch packages include a first switch package and a second switch package with the first switch package operating at a higher potential than the second switch package. The first set of openings can be configured to receive the connections with the first power terminals of the first switch package and the second set of openings can be configured to receive the connections with the first power terminals of the second switch package.

**[0084]** Optionally, the window opening in the plate extends closer to the second edge, closer to the third edge, and closer to the fourth edge of the plate than the slot.

**[0085]** Optionally, the slot divides the first edge of the plate in half

**[0086]** Optionally, the first set of openings is configured to receive the connections with the first power terminals of a first switch package of the switch packages. The second set of openings can be configured to receive the connections with the second power terminals of a second switch package of the switch packages.

**[0087]** Optionally, the plate of the load terminal connector is a first planar conductive plate. The bus bar also can include a supply terminal connector including a second planar conductive plate and a tab that protrudes from the second planar conductive plate. The second planar conductive plate can include a third set of openings configured to receive connections with the second power terminals of the switch packages. The tab can include a fourth set of openings configured to receive connections with a direct current (DC) bus of a DC link.

**[0088]** Optionally, the second planar conductive plate includes L-slots extending through the second planar conductive plate. The L-slots can be disposed between the tab and the third set of openings in the second planar conductive plate.

**[0089]** Optionally, the tab is a first tab, the DC bus is a lower voltage DC bus, and the supply terminal connector includes a third planar conductive plate and a second tab that protrudes from the third planar conductive plate in a direction that is opposite to a direction in which the first tab protrudes from the second planar conductive plate. The third planar conductive plate can include a fifth set of openings configured to receive connections with the first power terminals of the switch packages. The second tab can include a sixth set of openings configured to receive connections with a higher voltage DC bus of the DC link.

**[0090]** Optionally, the third planar conductive plate includes L-slots extending through the third planar conductive plate. The L-slots in the third conductive plate can be disposed between the second tab and the fifth set of openings in the third planar conductive plate.

**[0091]** In one embodiment, a bus bar includes a supply terminal connector including a first planar conductive plate and a first tab that protrudes from the first planar conductive

plate. The first planar conductive plate includes a first set of openings configured to receive connections with first power terminals of switch packages. The first tab includes a second set of openings configured to receive connections with a direct current (DC) bus of a DC link. The first planar conductive plate includes L-slots extending through the first planar conductive plate between the first tab and the first set of openings in the first planar conductive plate.

**[0092]** Optionally, the DC bus is a lower voltage DC bus, and the supply terminal connector includes a second planar conductive plate and a second tab that protrudes from the second planar conductive plate in a direction that is opposite to a direction in which the first tab protrudes from the first planar conductive plate. The second planar conductive plate can include a third set of openings configured to receive connections with second power terminals of the switch packages. The second tab can include a fourth set of openings configured to receive connections with a higher voltage DC bus of the DC link.

**[0093]** Optionally, the second planar conductive plate includes the L-slots extending through the second planar conductive plate between the second tab and the third set of openings in the second planar conductive plate.

**[0094]** Optionally, the bus bar also includes a load terminal connector formed from a third planar conductive plate that extends from a first edge to an opposite second edge and extends from a third edge to an opposite fourth edge. The third and fourth edges can extend from the first edge to the second edge. The third planar conductive plate can include a window opening located between the first and second edges and between the third and fourth edges. The third planar conductive plate also can include a slot extending into the third planar conductive plate from the first edge to the window opening. The third planar conductive plate can include fifth and sixth sets of the openings configured to receive connections with the first power terminals and the second power terminals of the switch packages. The fifth set of openings and the sixth set of openings can be located on opposite sides of the slot.

**[0095]** In one embodiment, a bus bar includes a load terminal connector formed from a first conductive plate that extends from a first edge to an opposite second edge and extends from a third edge to an opposite fourth edge. The third and fourth edges extend from the first edge to the second edge, the load terminal connector including a window opening located between the first and second edges and between the third and fourth edges. The plate also includes a slot extending into the plate from the first edge to the window opening. The load terminal connector also includes first and second sets of openings configured to receive connections with first and second power terminals of switch packages. The first set of openings and the second set of openings are located on opposite sides of the slot. The bus bar also includes a supply terminal connector including a second conductive plate and a first tab that protrudes from the second conductive plate. The second conductive plate includes a third set of openings configured to receive connections with the first power terminals of the switch packages. The first tab includes a fourth set of openings configured to receive connections with a direct current (DC) bus of a DC link.

**[0096]** Optionally, the first set of openings is located in the first conductive plate between the third edge and the slot and

the second set of openings is located in the first conductive plate between the fourth edge and the slot.

**[0097]** Optionally, the switch packages include a first switch package and a second switch package with the first switch package operating at a higher potential than the second switch package. The first set of openings can be configured to receive the connections with the second power terminals of the first switch package and the second set of openings is configured to receive the connections with the second power terminals of the second switch package.

**[0098]** Optionally, the window opening in the first conductive plate extends closer to the second edge, closer to the third edge, and closer to the fourth edge of the first conductive plate than the slot, the slot divides the first edge of the first conductive plate in half. The first set of openings can be configured to receive the connections with the second power terminals of a first switch package of the switch packages. The second set of openings can be configured to receive the connections with the first power terminals of a second switch package of the switch packages.

**[0099]** Optionally, the second conductive plate includes L-slots extending through the second conductive plate. The L-slots can be disposed between the tab and the third set of openings in the second conductive plate.

**[0100]** Optionally, the DC bus is a lower voltage DC bus, and the supply terminal connector includes a third conductive plate and a second tab that protrudes from the third conductive plate in a direction that is opposite to a direction in which the first tab protrudes from the second conductive plate. The third conductive plate can include a fifth set of openings configured to receive connections with the second power terminals of the switch packages. The second tab can include a sixth set of openings configured to receive connections with a higher voltage DC bus of the DC link.

**[0101]** It is to be understood that the above description is intended to be illustrative, and not restrictive. For example, the above-described embodiments (and/or aspects thereof) may be used in combination with each other. In addition, many modifications may be made to adapt a particular situation or material to the teachings of the inventive subject matter without departing from its scope. While the dimensions and types of materials described herein are intended to define the parameters of the inventive subject matter, they are by no means limiting and are exemplary embodiments. Many other embodiments will be apparent to those of skill in the art upon reviewing the above description. In the appended clauses, the terms “including” and “in which” are used as the plain-English equivalents of the respective terms “comprising” and “wherein.” Moreover, in the following clauses, terms such as “first,” “second,” “third,” “upper,” “lower,” “bottom,” “top,” etc. are used merely as labels, and are not intended to impose numerical or positional requirements on their objects. Further, the limitations of the following clauses are not written in means-plus-function format and are not intended to be interpreted based on 35 U.S.C. § 112, sixth paragraph, unless and until such clause limitations expressly use the phrase “means for” followed by a statement of function void of further structure.

**[0102]** This written description uses examples to disclose several embodiments of the inventive subject matter, including the best mode, and also to enable one of ordinary skill in the art to practice embodiments of the inventive subject matter, including making and using any devices or systems and performing any incorporated methods.

**[0103]** As used herein, an element or step recited in the singular and proceeded with the word “a” or “an” should be understood as not excluding plural of the elements or steps, unless such exclusion is explicitly stated. Furthermore, references to “one embodiment” of the inventive subject matter are not intended to be interpreted as excluding the existence of additional embodiments that also incorporate the recited features. Moreover, unless explicitly stated to the contrary, embodiments “comprising,” “including,” or “having” an element or a plurality of elements having a particular property may include additional such elements not having that property.

**[0104]** Since certain changes may be made in the subject matter described above, without departing from the spirit and scope of the inventive subject matter herein involved, it is intended that all of the subject matter of the above description or shown in the accompanying drawings shall be interpreted merely as examples illustrating the inventive concept herein and shall not be construed as limiting the inventive subject matter.

What is claimed is:

1. A bus bar comprising:

a supply terminal connector assembly extending from a first lateral side to an opposite second lateral side, the supply terminal connector assembly including one or more first holes configured for connection with one or more collector terminals of a high potential switch element and one or more second holes for connection with one or more emitter terminals of a low potential switch element,

the supply terminal connector assembly also including first and second tabs protruding from the supply terminal connector assembly, the first tab including one or more third holes configured for connection with a direct current (DC) high potential bus, the second tab including one or more fourth holes configured for connection with a DC low potential bus,

the first and second tabs offset from each other such that the first tab is closer to the first lateral side of the supply terminal connector assembly than the second tab and the second tab is closer to the second lateral side of the supply terminal connector assembly than the first tab.

2. The bus bar of claim 1, wherein the supply terminal connector assembly includes one or more L-shaped slots between (a) the one or more first holes or the one or more second holes and (b) the one or more third holes or the one or more fourth holes.

3. The bus bar of claim 1, wherein the supply terminal connector assembly includes a first supply terminal connector and a second supply terminal connector, the first supply terminal connector including the one or more first holes and the first tab, the second supply terminal connector including the one or more second holes and the second tab.

4. The bus bar of claim 1, wherein the first tab and the second tab protrude away from each other in opposite directions.

5. The bus bar of claim 1, wherein the first tab and the second tab are transversely oriented relative to the supply terminal connector assembly.

6. The bus bar of claim 1, further comprising:

a load terminal connector including one or more fifth holes configured for connection with one or more emitter terminals of the high potential switch element, the load terminal connector including one or more sixth



holes configured for connection with one or more collector terminals of the low potential switch element.

7. The bus bar of claim 6, wherein the load terminal connector includes a window extending through the load terminal connector.

8. The bus bar of claim 7, wherein the load terminal connector includes an elongated slot extending from the window to a location between the one or more fifth holes and the one or more sixth holes.

9. A bus bar comprising:

a supply terminal connector assembly extending from a first lateral side to an opposite second lateral side, the supply terminal connector assembly including one or more first holes configured for connection with one or more collector terminals of a first switch element and one or more second holes for connection with one or more emitter terminals of a second switch element,

the supply terminal connector assembly also including first and second tabs protruding from the at least the second conductive plate, the first tab including one or more third holes configured for connection with a first direct current (DC) bus, the second tab including one or more fourth holes configured for connection with a second DC bus,

the first and second tabs offset from each other such that the first tab is closer to the first lateral side of the supply terminal connector assembly than the second tab and the second tab is closer to the second lateral side of the supply terminal connector assembly than the first tab.

10. The bus bar of claim 9, wherein the supply terminal connector assembly includes one or more L-shaped slots between (a) the one or more first holes or the one or more second holes and (b) the one or more third holes or the one or more fourth holes.

11. The bus bar of claim 9, wherein the supply terminal connector assembly includes a first supply terminal connector and a second supply terminal connector, the first supply terminal connector including the one or more first holes and the first tab, the second supply terminal connector including the one or more second holes and the second tab.

12. The bus bar of claim 9, wherein the first tab and the second tab protrude away from each other in opposite directions.

13. The bus bar of claim 9, wherein the first tab and the second tab are transversely oriented relative to the supply terminal connector assembly.

14. The bus bar of claim 9, further comprising:

a load terminal connector including one or more fifth holes configured for connection with one or more emitter terminals of the first switch element, the load terminal connector including one or more sixth holes configured for connection with one or more collector terminals of the second switch element.

15. The bus bar of claim 14, wherein the load terminal connector includes a window extending through the load terminal connector.

16. The bus bar of claim 15, wherein the load terminal connector includes an elongated slot extending from the window to a location between the one or more fifth holes and the one or more sixth holes.

17. A bus bar comprising:

a supply terminal connector assembly comprising a first conductive plate and a second conductive plate each extending from a first lateral side to an opposite second lateral side, the first conductive plate including one or more first holes configured for connection with one or more collector terminals of a first switch element, the second conductive plate including one or more second holes for connection with one or more emitter terminals of a second switch element,

the first conductive plate including a first tab and the second conductive plate including a second tab, the first tab including one or more third holes configured for connection with a first direct current (DC) bus, the second tab including one or more fourth holes configured for connection with a second DC bus,

the first and second tabs offset from each other such that the first tab is closer to the first lateral side of the first and second conductive plates than the second tab and the second tab is closer to the second lateral side of the first and second conductive plates than the first tab.

18. The bus bar of claim 17, wherein the supply terminal connector assembly includes one or more L-shaped slots between (a) the one or more first holes or the one or more second holes and (b) the one or more third holes or the one or more fourth holes.

19. The bus bar of claim 17, wherein the first tab and the second tab protrude away from each other in opposite directions.

20. The bus bar of claim 17, wherein the first tab and the second tab are transversely oriented relative to the both the first conductive plate and the second conductive plate.

\* \* \* \* \*