



US 20210082638A1

(19) **United States**

(12) **Patent Application Publication**
OGAWA et al.

(10) **Pub. No.: US 2021/0082638 A1**

(43) **Pub. Date: Mar. 18, 2021**

(54) **PUSH-BUTTON SWITCH**

H01H 3/20 (2006.01)

H01H 13/10 (2006.01)

H01H 13/44 (2006.01)

H01H 13/52 (2006.01)

H01H 3/04 (2006.01)

(71) Applicant: **OMRON Corporation**, Kyoto-shi,
Kyoto (JP)

(72) Inventors: **Tadahiko OGAWA**, Moriyama-shi,
Shiga (JP); **Kazuaki MORITA**,
Okayama-shi, Okayama (JP); **Yusuke**
KOMOGUCHI, Okayama-shi,
Okayama (JP); **Masami NISHIDA**,
Osaka-shi, Osaka (JP)

(52) **U.S. Cl.**

CPC *H01H 13/14* (2013.01); *H01H 13/04*
(2013.01); *H01H 3/20* (2013.01); *H01H 3/04*
(2013.01); *H01H 13/44* (2013.01); *H01H*
13/52 (2013.01); *H01H 13/10* (2013.01)

(21) Appl. No.: **16/644,774**

(22) PCT Filed: **Nov. 30, 2018**

(86) PCT No.: **PCT/JP2018/044229**

§ 371 (c)(1),

(2) Date: **Mar. 5, 2020**

(30) **Foreign Application Priority Data**

Dec. 28, 2017 (JP) 2017-254316

Publication Classification

(51) **Int. Cl.**

H01H 13/14 (2006.01)

H01H 13/04 (2006.01)

(57) **ABSTRACT**

A push-button switch may include a housing, an operation unit, a lock lever unit, a transmission mechanism, a movement regulating portion, a contact mechanism, and a first biasing portion. The movement regulating portion enables movement of a lever body to a second position when an end of the operation unit on a housing portion side is positioned at an initial position, and disables movement of the lever body to the second position when the end of the operation unit on the housing portion side is positioned closer to an operation surface than the initial position in a movable direction. The first biasing portion biases the plunger from an operating position toward a return position.

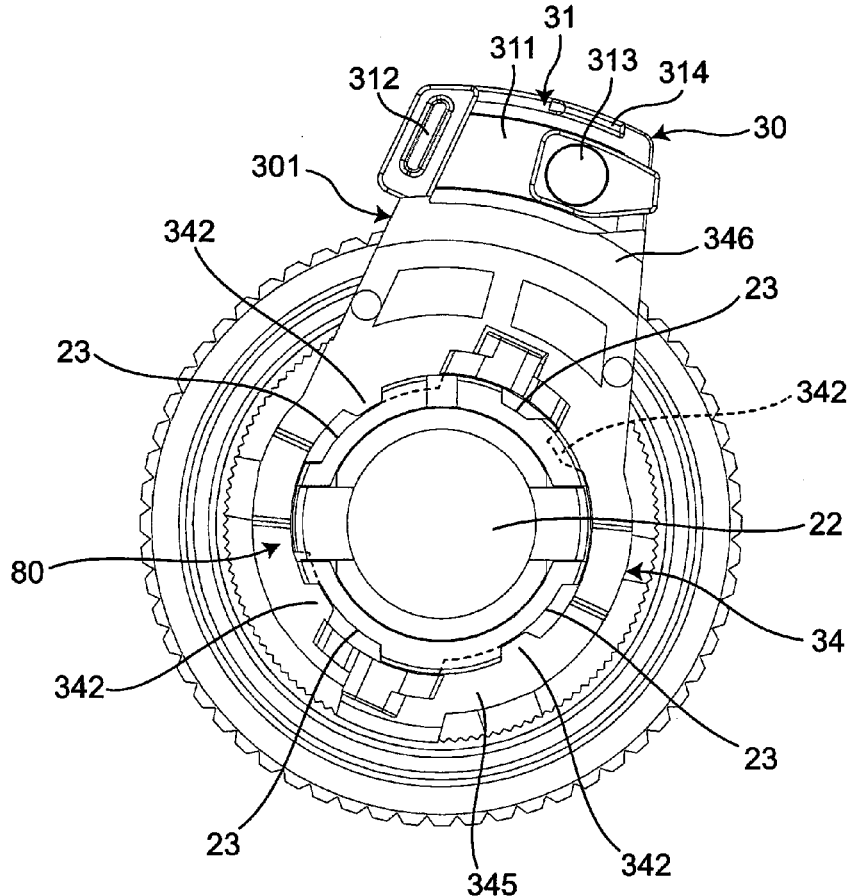

Fig. 1

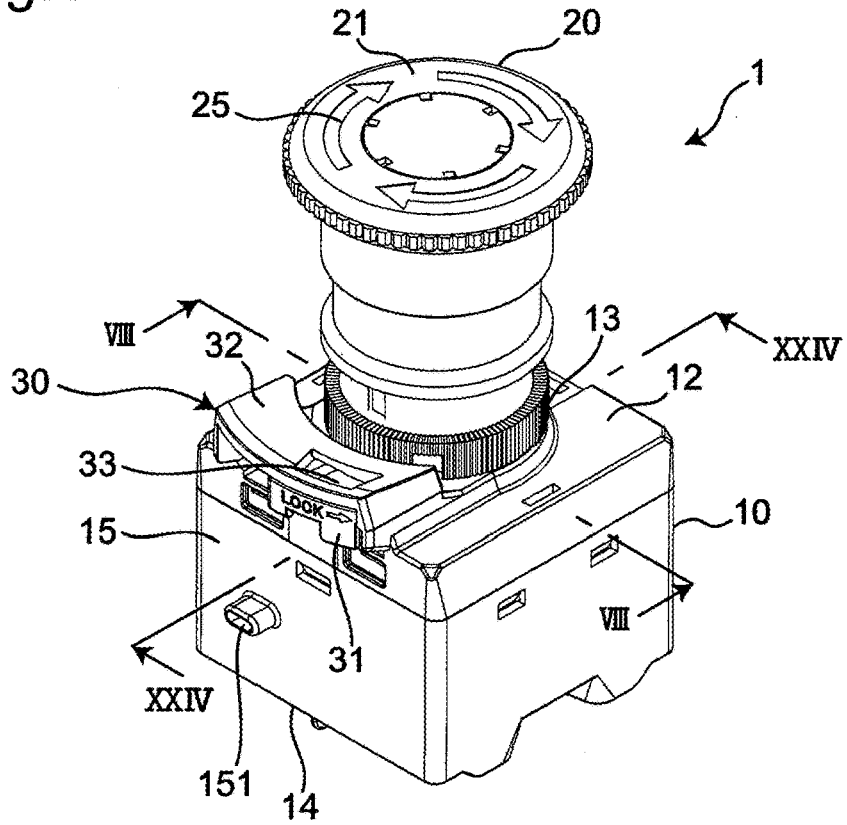

Fig. 2

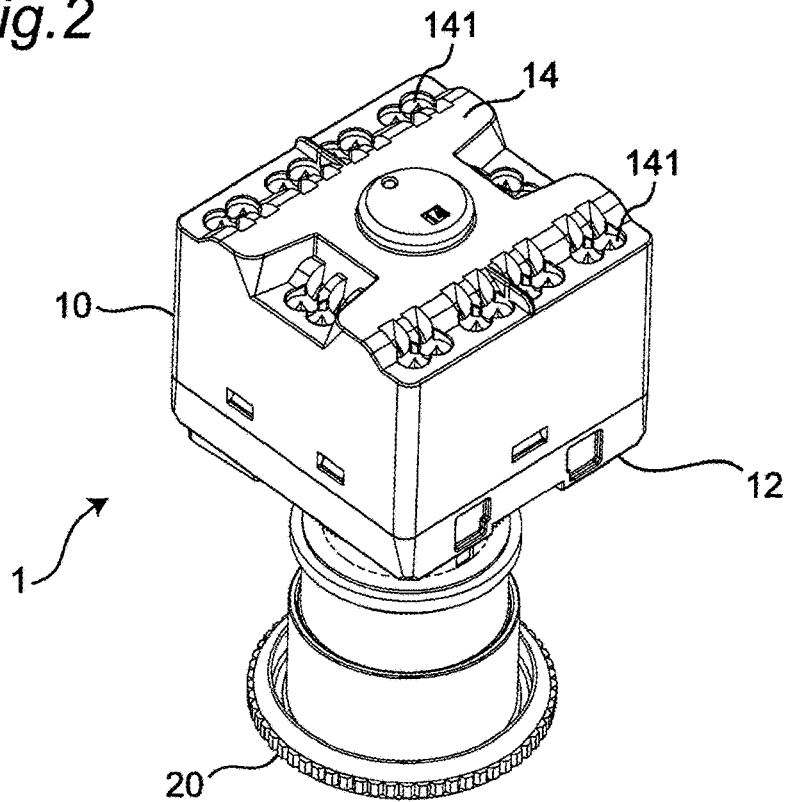

Fig.3

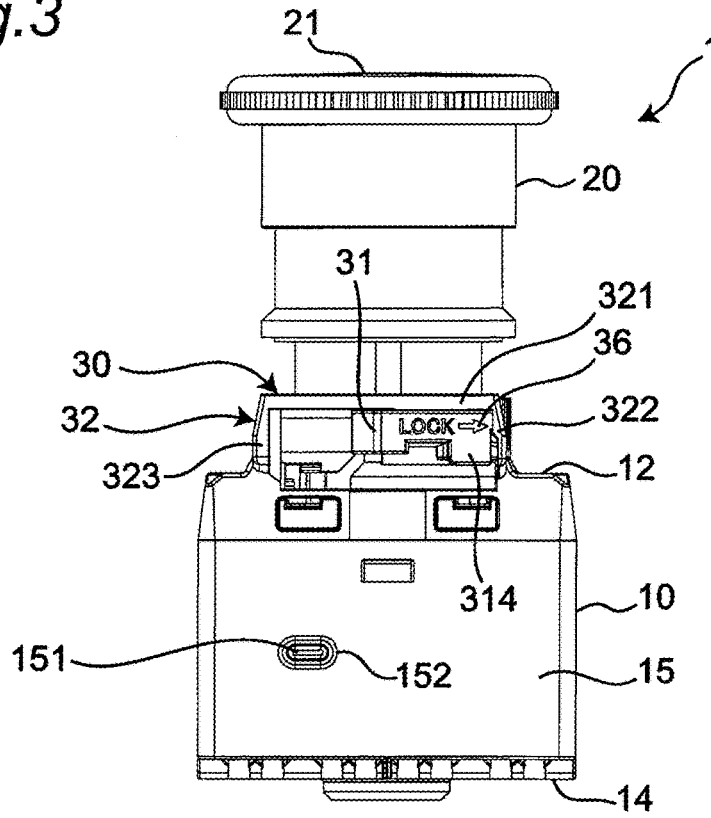

Fig.4

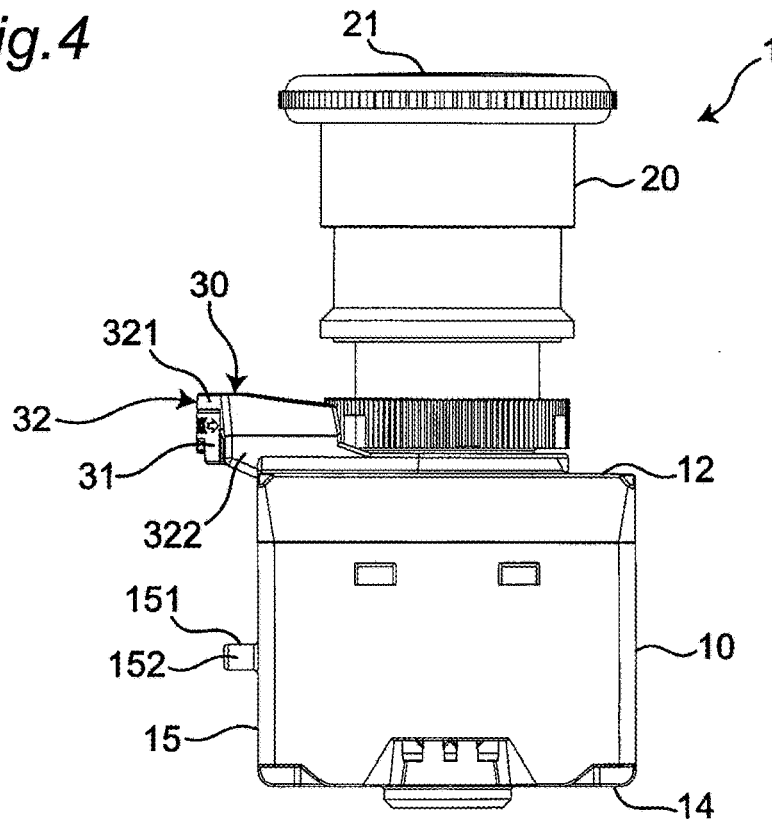

Fig.5

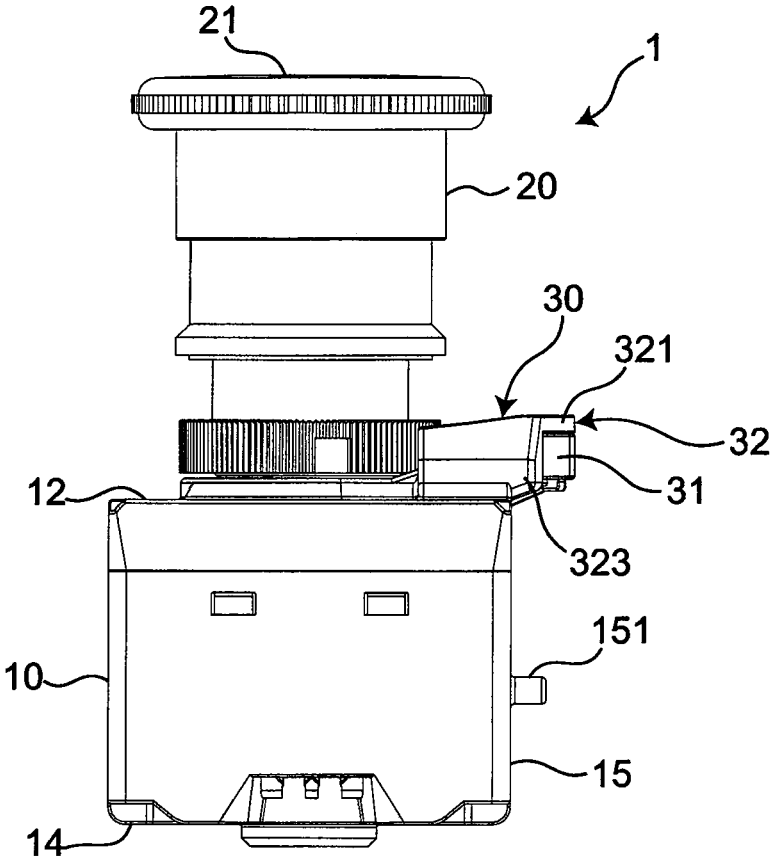

Fig. 6

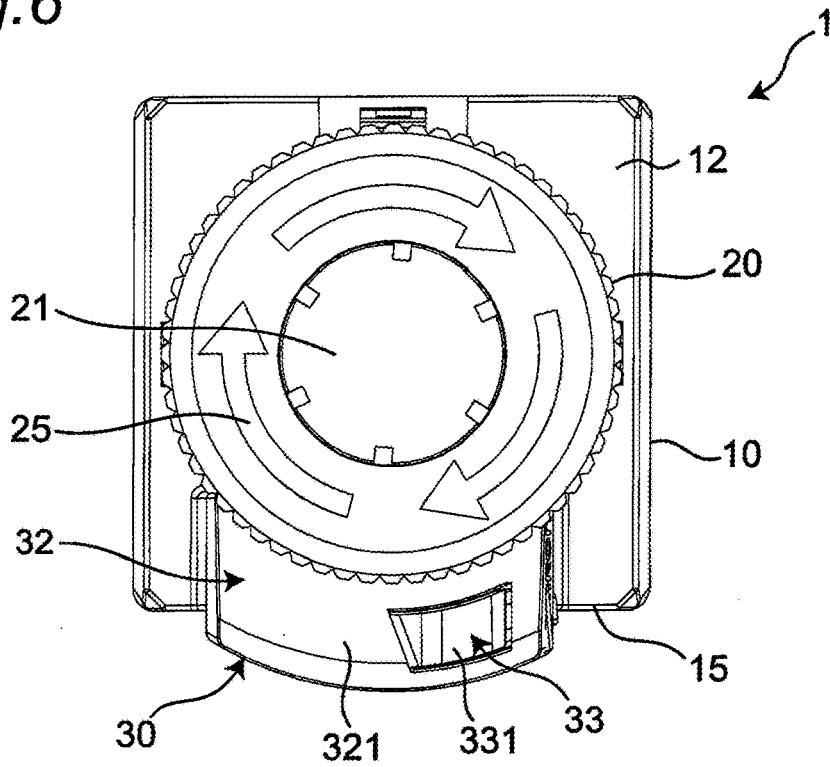

Fig. 7

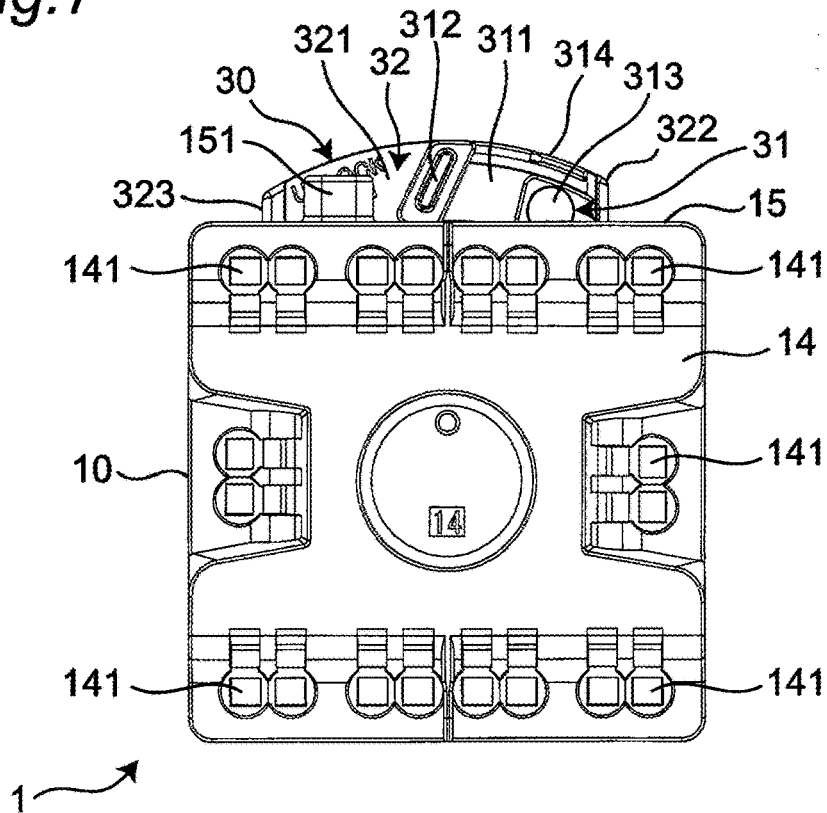

Fig. 8

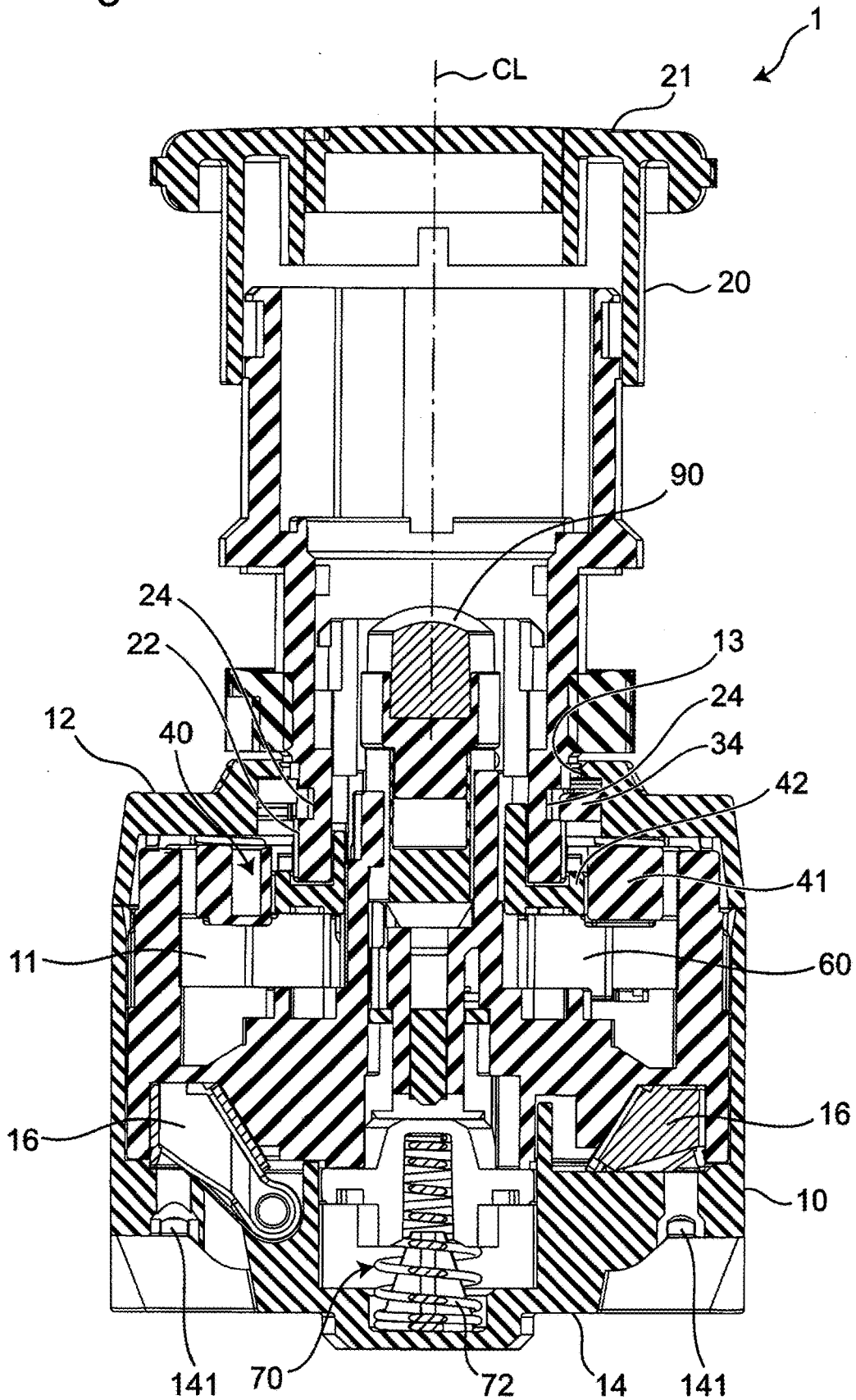

Fig. 9

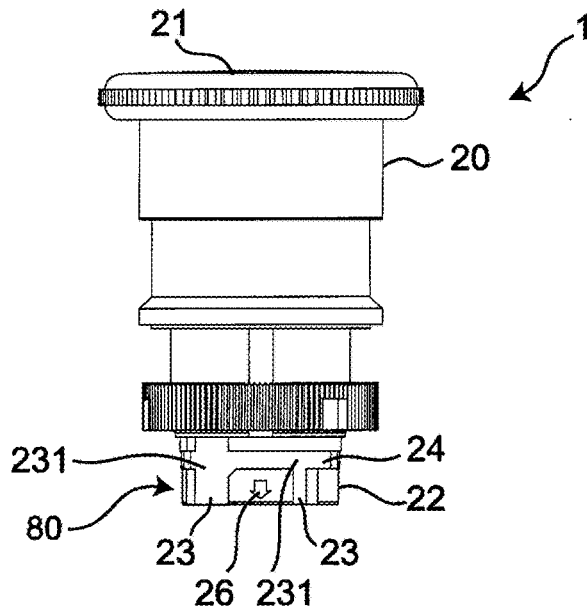

Fig. 10

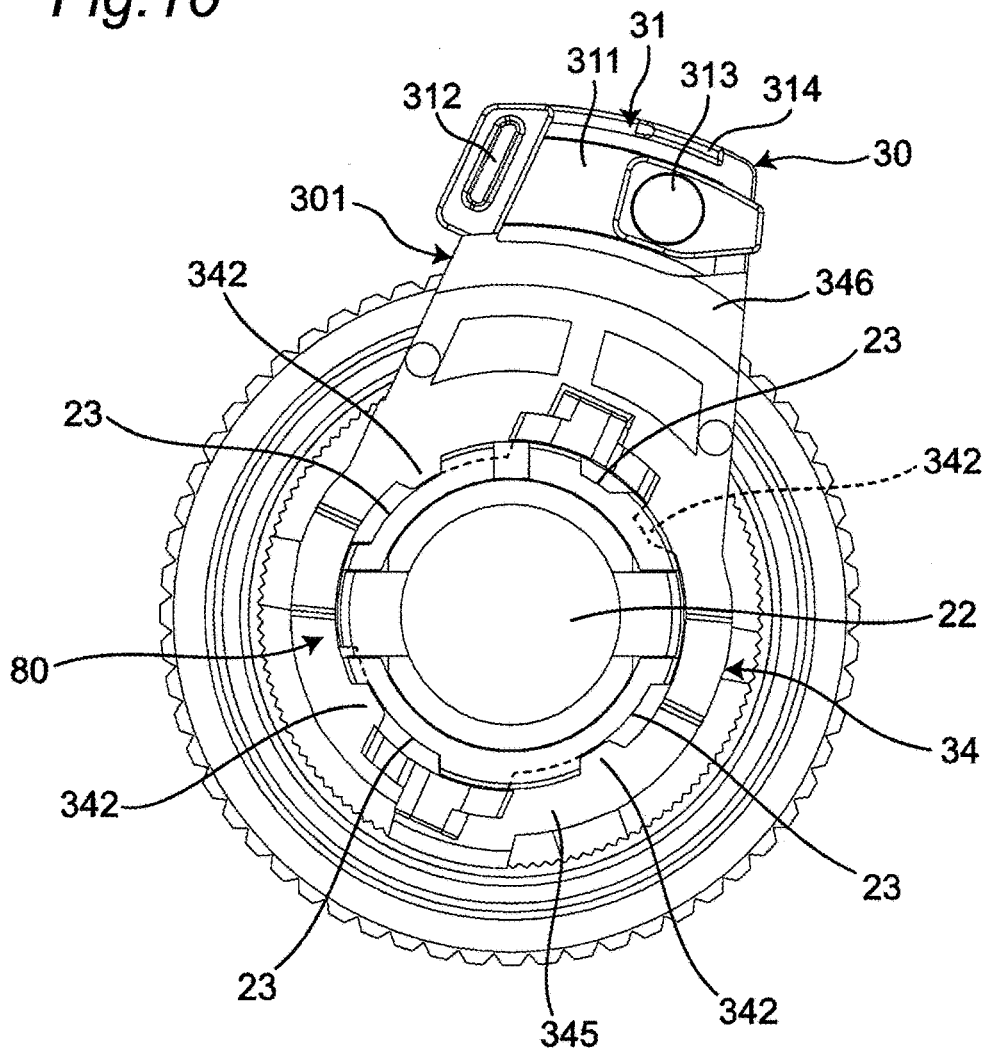

Fig. 11

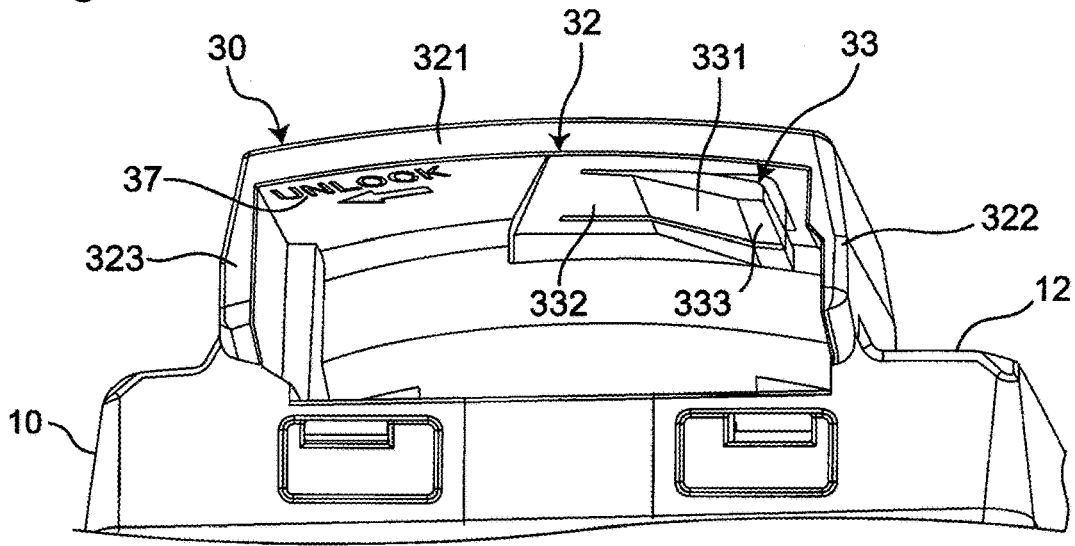

Fig. 12

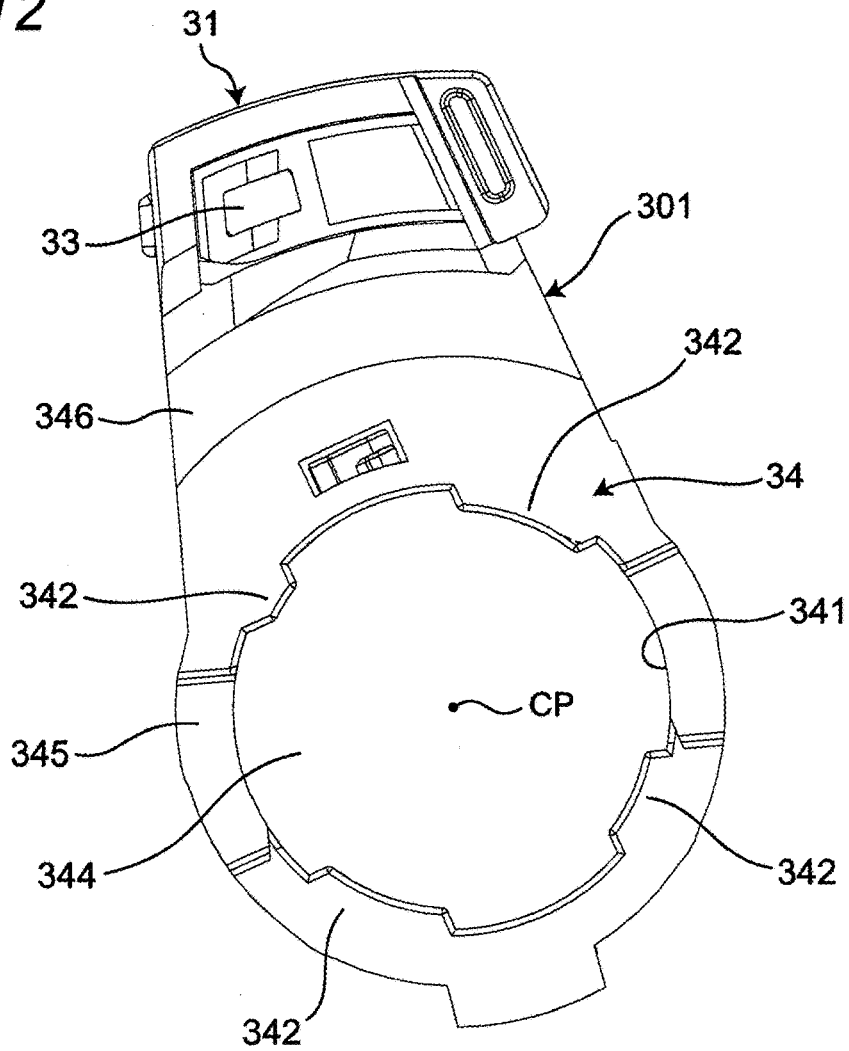

Fig. 13

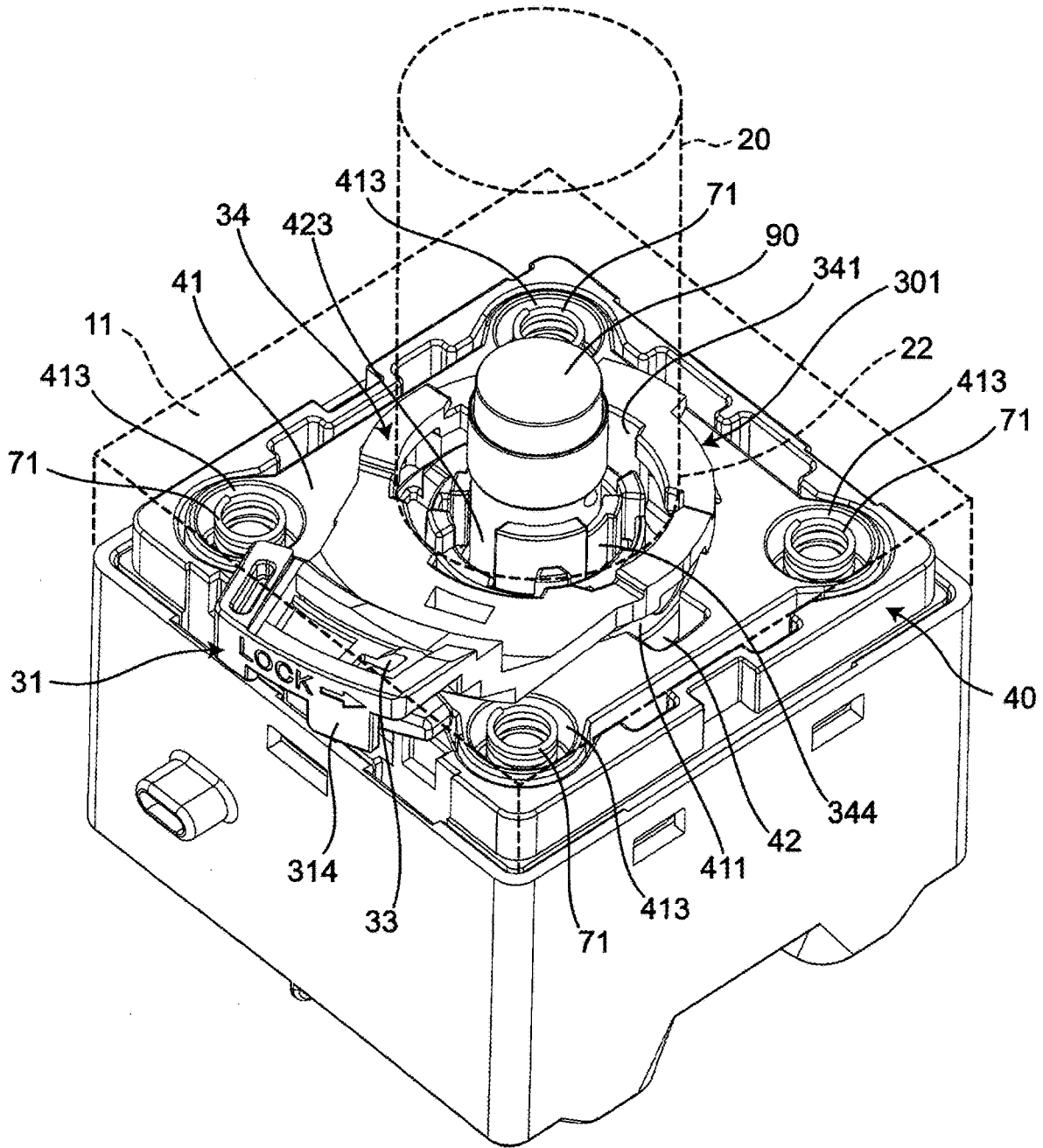

Fig. 14

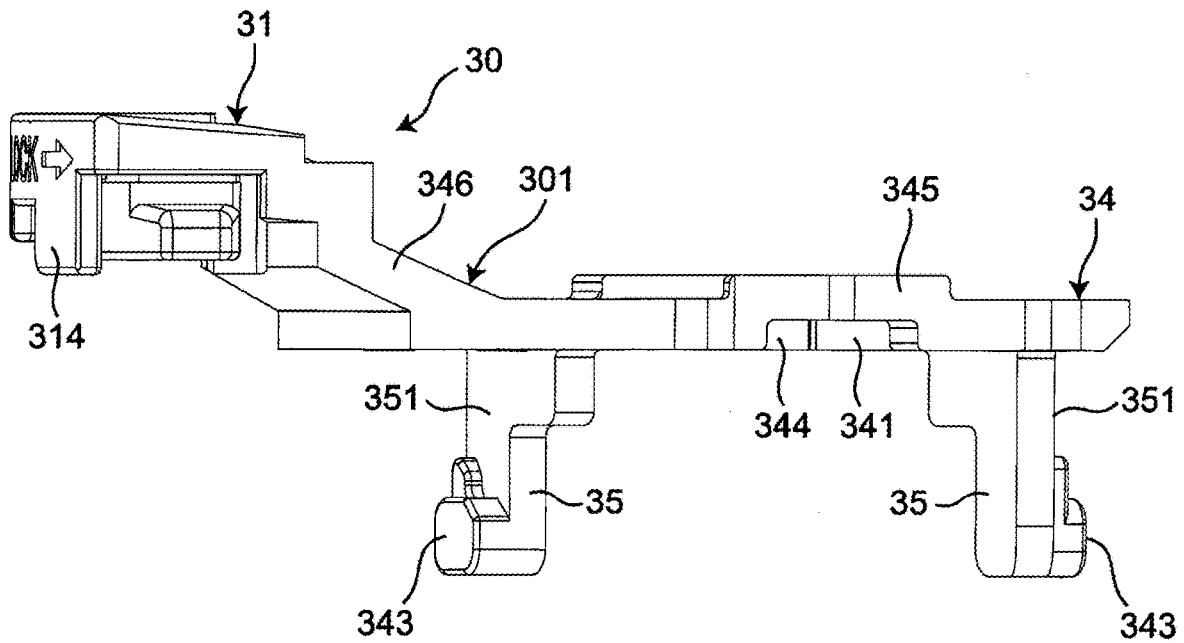

Fig. 15

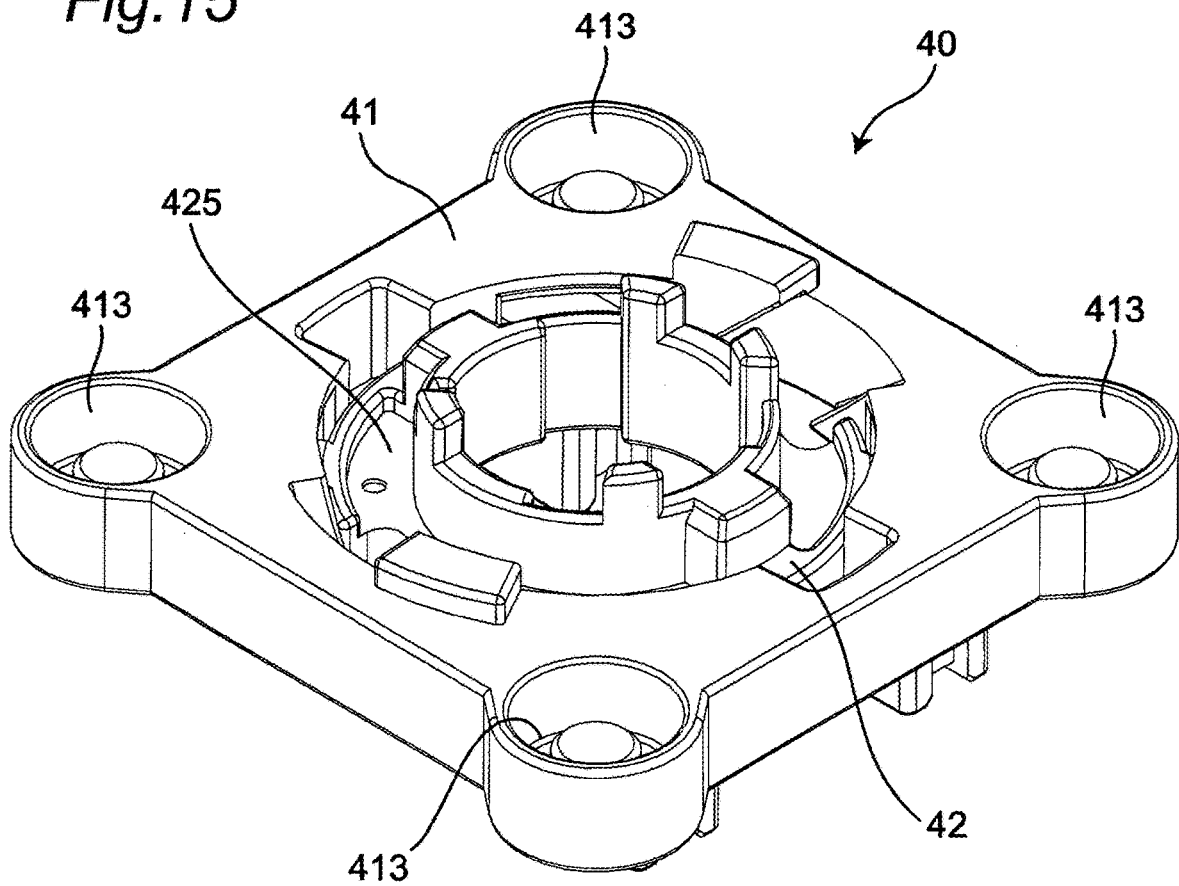

Fig. 16

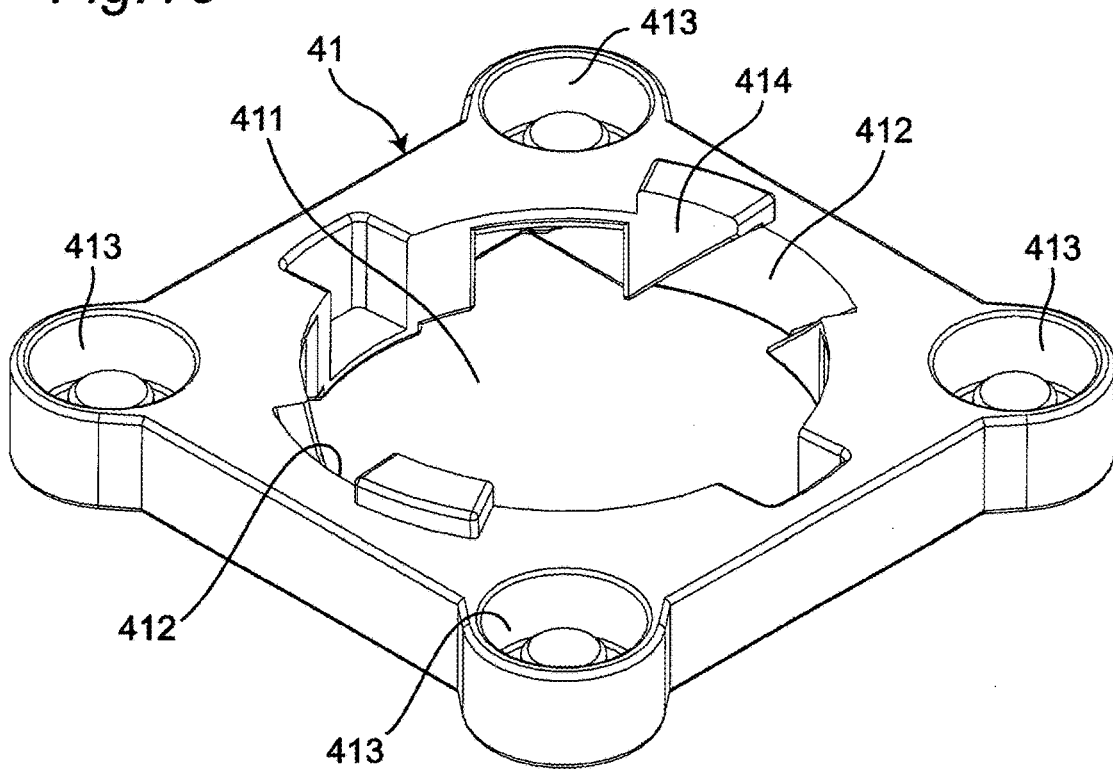

Fig. 17

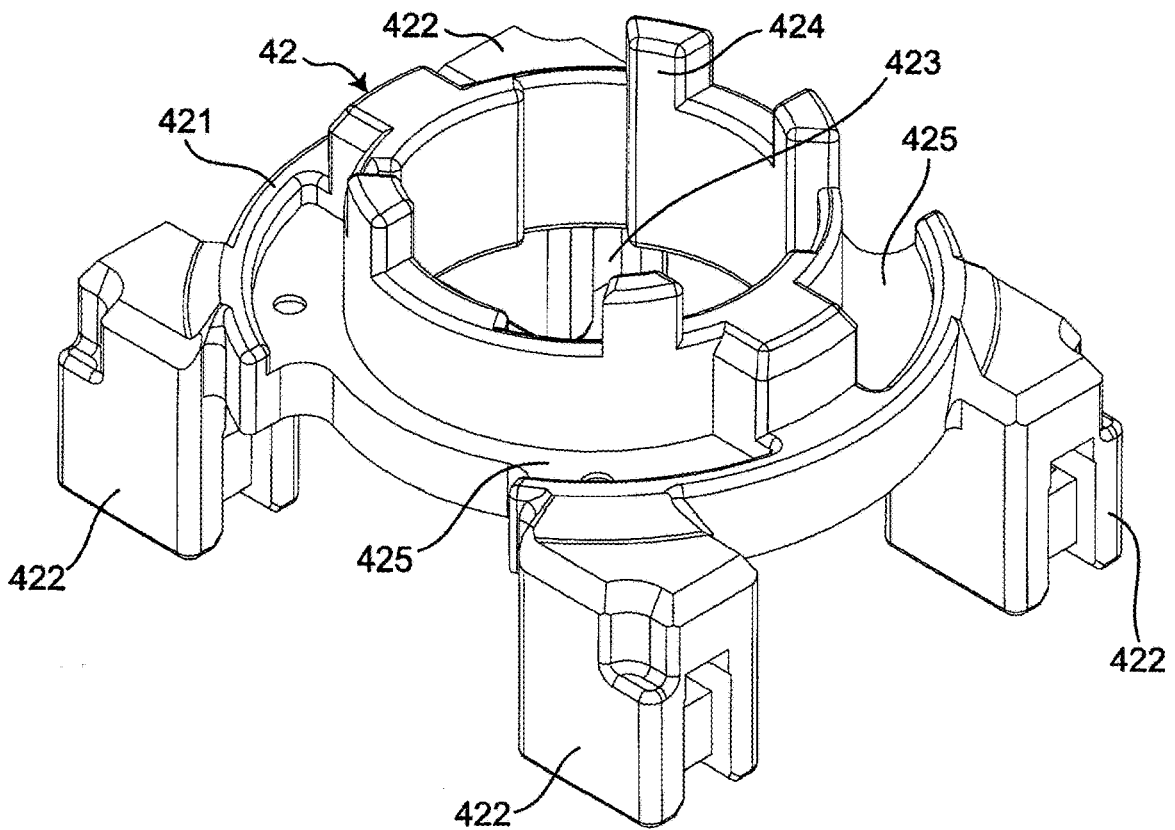

Fig. 18

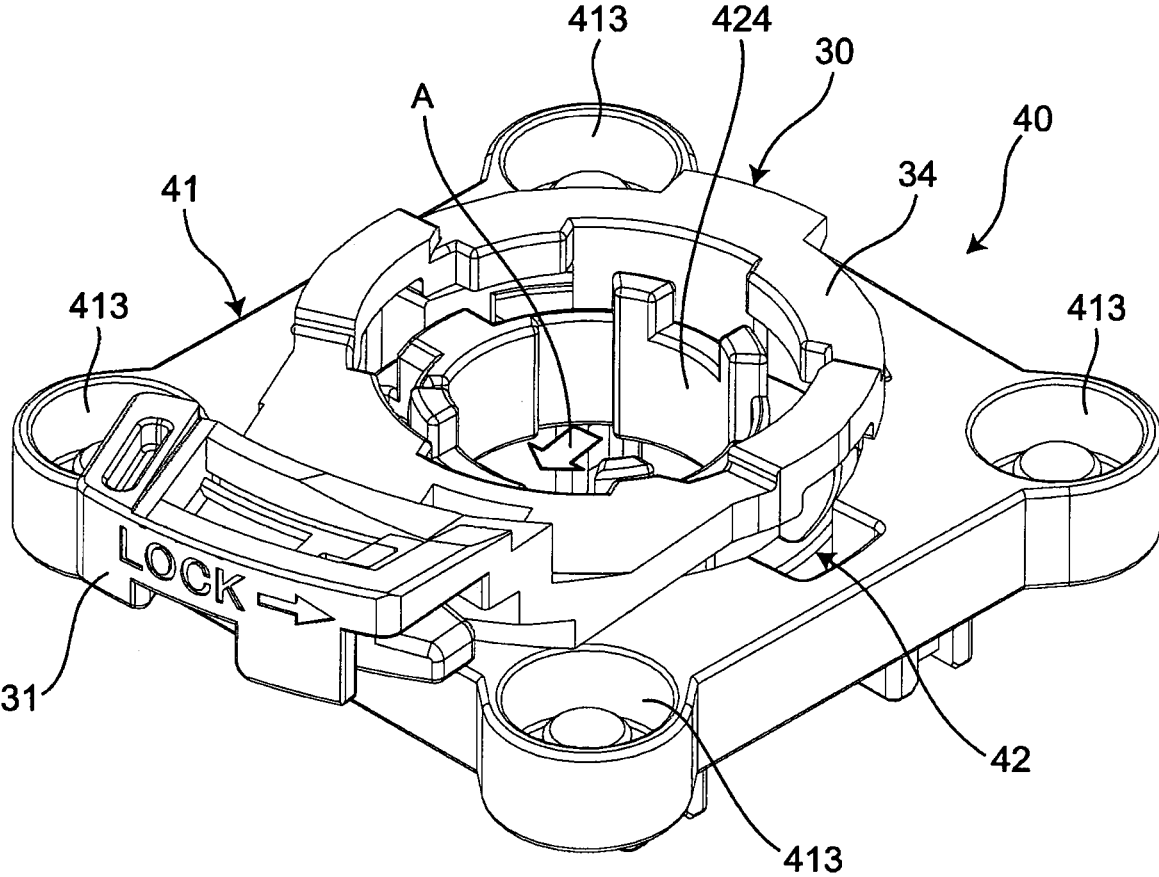

Fig. 19

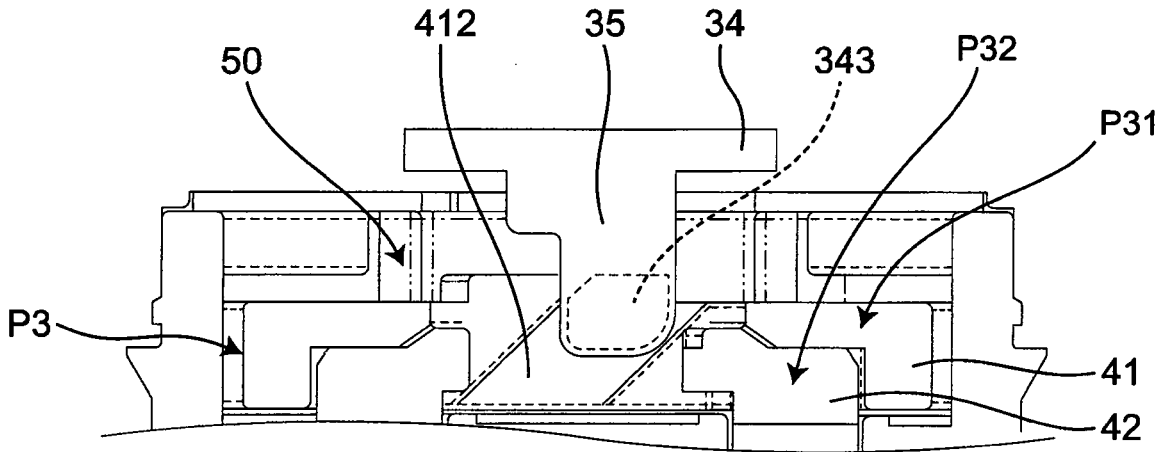

Fig. 20

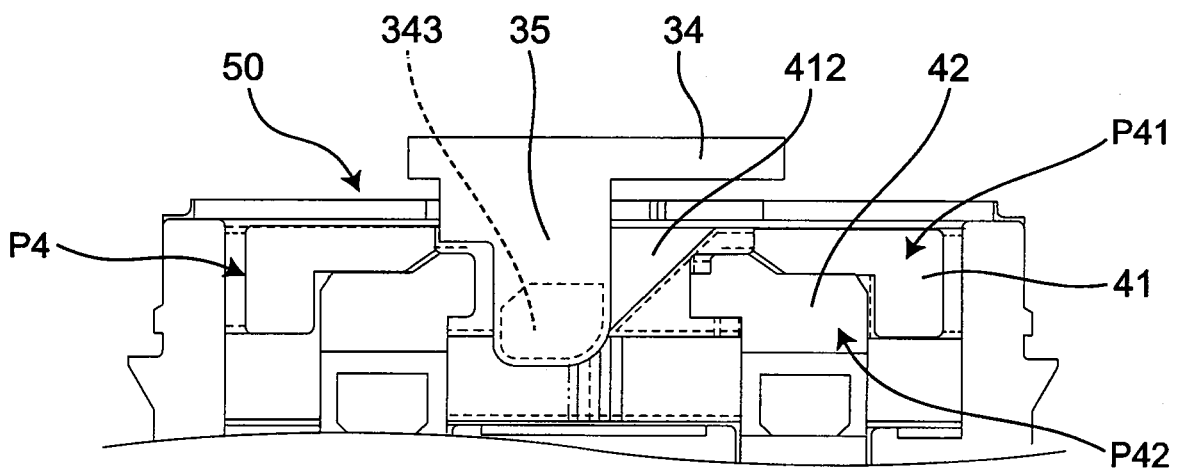

Fig.21

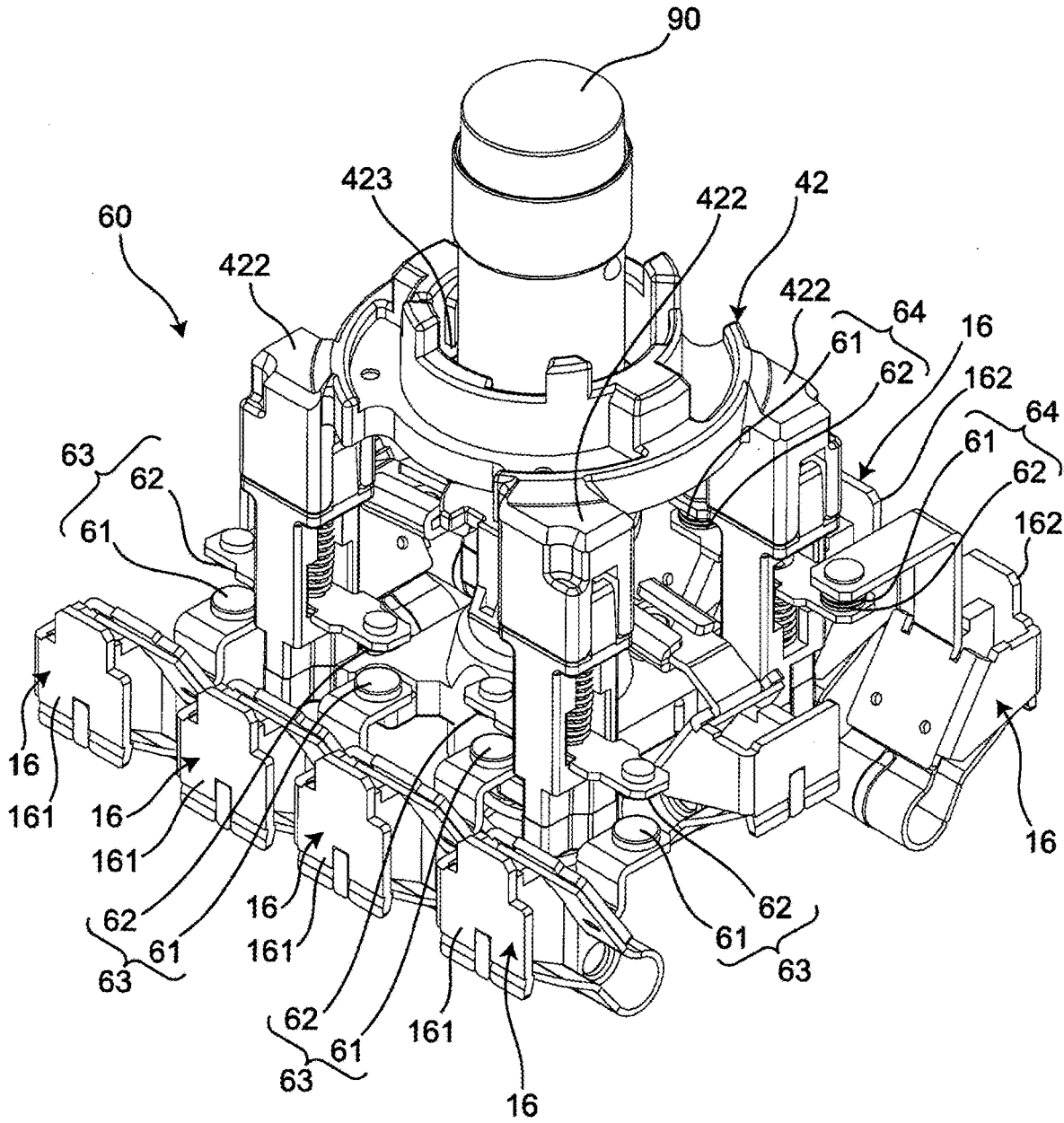

Fig.22

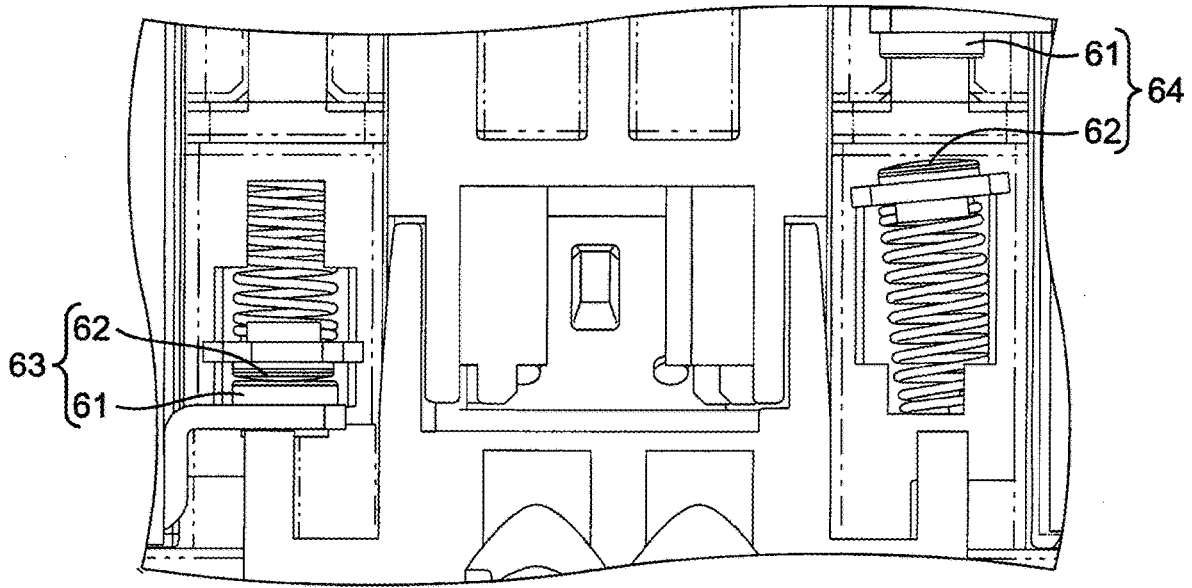
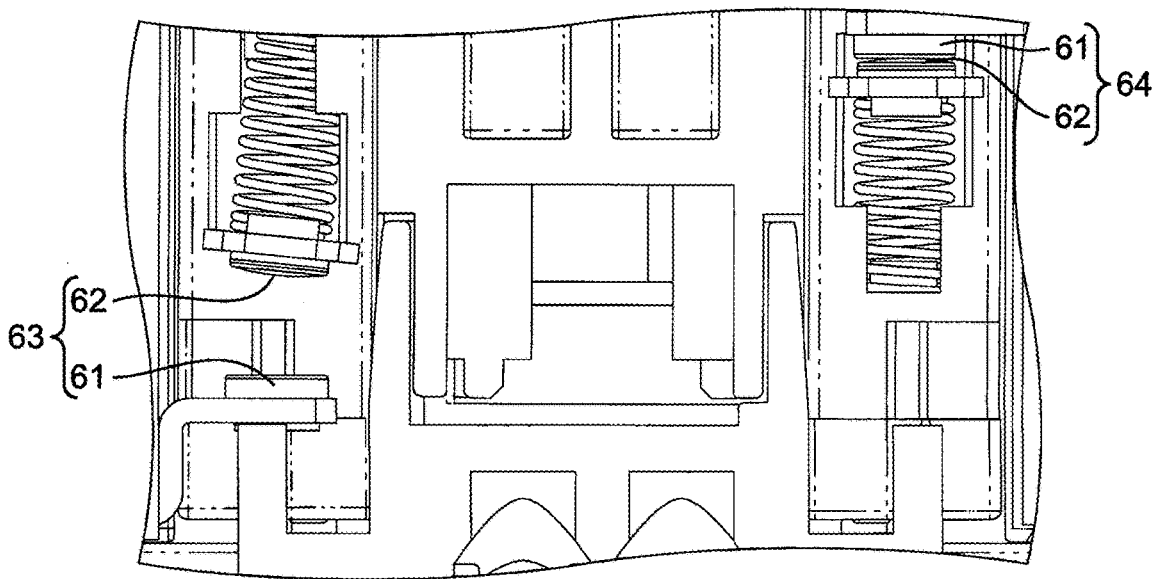

Fig.23



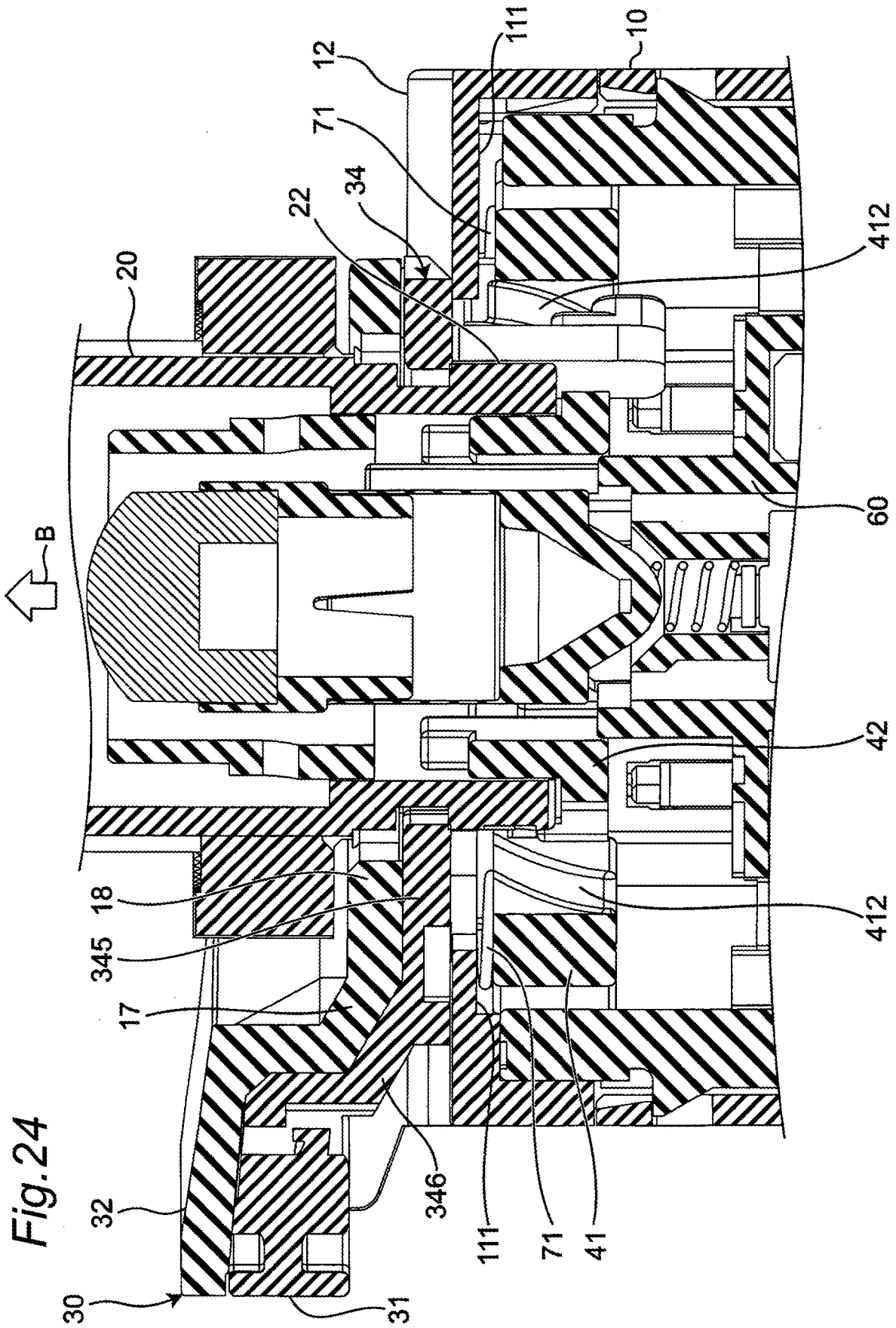

Fig.25

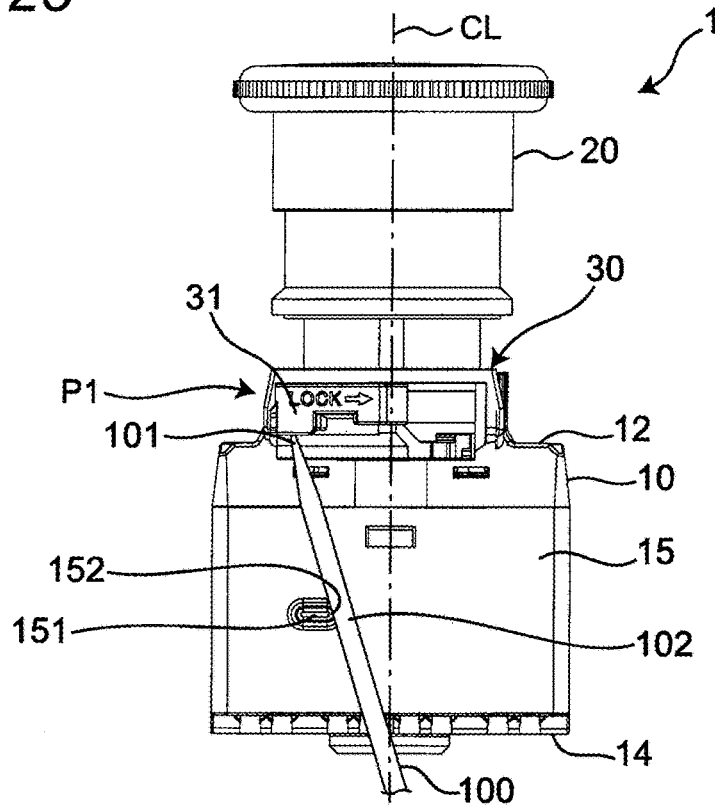

Fig.26

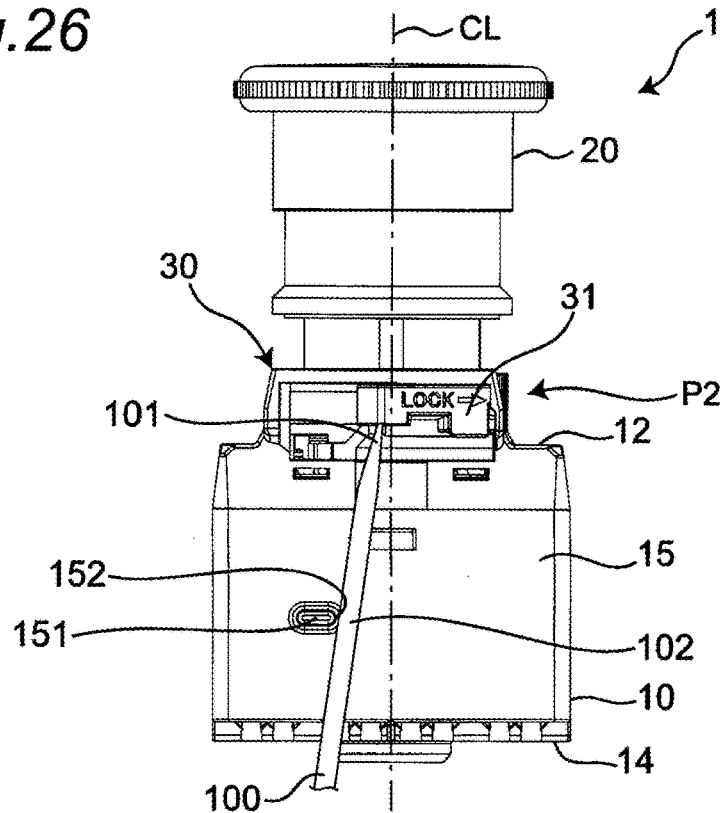

Fig.27

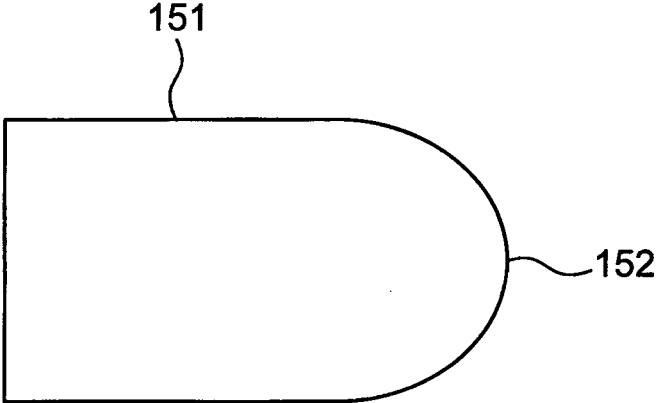

Fig.28

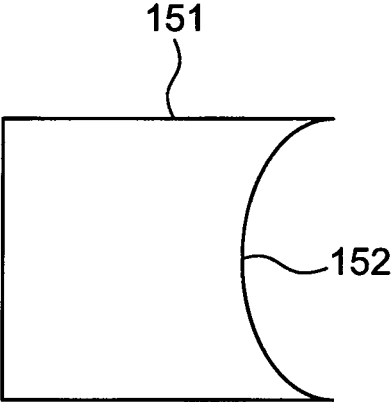
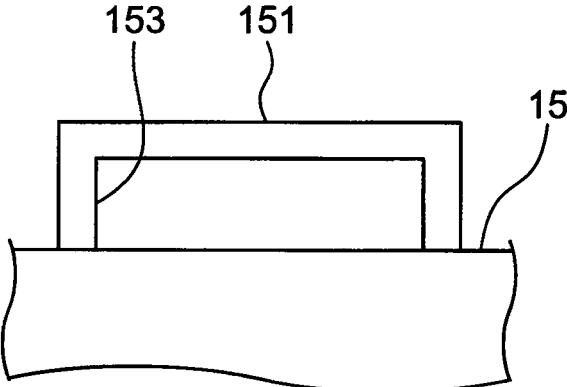

Fig.29



PUSH-BUTTON SWITCH

TECHNICAL FIELD

[0001] The present disclosure relates to a push-button switch provided with a lock lever unit.

BACKGROUND ART

[0002] Patent document 1 discloses an operation switch including a contact portion having a contact B, an operation unit for opening and closing the contact B of the contact portion, and a lock mechanism having a lock lever capable of fixing the operation unit and the contact portion to each other. The lock lever is provided with a cam that rotates in conjunction with the rotation operation of the lock lever and is configured so that the contact B of the contact portion can be opened and closed.

[0003] In the operation switch, it is configured such that the lock lever is moved to the fully locked position in a state where one end of the operation unit is fitted into the mounting hole provided in the contact portion, and thereby the operation unit is fixed to the contact portion, and the contact B is switched from the off state to the on state at the same time.

RELATED ART DOCUMENTS

Patent Documents

[0004] Patent document 1: Japanese Patent No. 4147049

SUMMARY OF INVENTION

Technical Problem

[0005] In the operation switch, when the operation unit is mounted to the contact portion, for example, in a state of being inclined with respect to the contact portion, or in a state in which one end of the operation unit is sufficiently inserted into the mounting hole of the contact portion, and the lock lever is operated, there is a case where such an incompletely mounted state of the operation unit cannot be determined from the outside, and the performance and safety of the operation switch cannot not be ensured.

[0006] An object of the present disclosure is to provide a push-button switch capable of reliably mounting an operation unit in a complete state.

Solution to Problem

[0007] A push-button switch according to an example of the present disclosure includes:

[0008] a housing having an operation surface provided with an operation hole and a housing portion provided therein and connected to the operation hole;

[0009] a plunger provided at an inside of the housing portion and movable between a return position away from the operation surface and an operating position in the middle between the operation surface and the return position along a movable direction intersecting the operation surface;

[0010] an operation unit that extends along the movable direction from an outside of the housing through the operation hole to the inside of the housing portion and is mounted to the housing in a state in which an end on the housing portion side in an extending direction is positioned at an initial position, and has a pressing surface provided at the

outside of the housing and disposed so as to face the operation surface, in which the pressing surface is capable of an approaching operation with respect to the operation surface along the movable direction, and the end on the housing portion side moves from the initial position to a pressing position to position the plunger at the return position by the approaching operation;

[0011] a lock lever unit that has a lever body exposed to the outside of the housing and movable in a direction intersecting the movable direction between a first position and a second position, a lever support portion provided at the inside of the housing portion and connected to the lever body so as to be movable together with the lever body, and a holding unit capable of holding the lever body at the second position;

[0012] a transmission mechanism that is provided between the lock lever unit and the plunger inside the housing portion, moves the plunger from the return position to the operating position along the movable direction as the lever body moves from the first position toward the second position, but moves the plunger from the operating position to the return position along the movable direction as the lever body moves from the second position toward the first position;

[0013] a movement regulating portion that is provided between the operation unit and the lock lever unit inside the housing portion, and when the lever body is positioned at the first position, enables movement of the lever body to the second position when the end of the operation unit on the housing portion side is positioned at the initial position, but disables movement of the lever body to the second position when the end of the operation unit on the housing portion side is positioned closer to the operation surface than the initial position in the movable direction;

[0014] a contact mechanism that has a fixed contact portion provided at the inside of the housing portion and a movable contact portion that is provided at the inside of the housing portion so as to face the fixed contact portion, comes into contact with the fixed contact portion when the plunger moves from the return position to the operating position, and separates from the fixed contact portion when the plunger moves from the operating position to the return position; and

[0015] a first biasing portion provided at the inside of the housing portion and biasing the plunger from the operating position toward the return position along the movable direction.

Advantageous Effects of Invention

[0016] According to the push-button switch, it includes a lock lever unit having a lever body movable between a first position and a second position and a holding unit capable of holding the lever body at the second position, a transmission mechanism that moves a plunger from a return position to an operating position as the lever body moves from the first position toward the second position, and moves the plunger from the operating position to the return position as the lever body moves from the second position toward the first position, a movement regulating portion that, when the lever body is positioned at the first position, enables movement of the lever body to the second position when the end of the operation unit on the housing portion side is positioned at an initial position, but disables movement of the lever body to the second position when the end of the operation unit on the

housing portion side is positioned closer to the operation surface than the initial position, and a first biasing portion that biases the plunger from the operating position toward the return position. That is, in the push-button switch, for example, when the operation unit once removed for maintenance or the like is attached to the housing, when the end of the operation unit on the housing portion side is positioned at the initial position, the lever body can be moved to the second position and held by the holding unit, while when the end of the operation unit on the housing portion side is positioned closer to the operation surface than the initial position in the movable direction, the lever body cannot be moved to the second position, and the lever body is biased by the first biasing portion via the plunger to move to the first position. This makes it possible to realize a push-button switch in which the operation unit can be reliably attached in a complete state.

BRIEF DESCRIPTION OF DRAWINGS

[0017] FIG. 1 is a perspective view of a push-button switch according to an embodiment of the present disclosure.

[0018] FIG. 2 is a perspective view of the push-button switch of FIG. 1 when viewed from a direction different from that of FIG. 1.

[0019] FIG. 3 is a front view of the push-button switch of FIG. 1.

[0020] FIG. 4 is a right-side view of the push-button switch in FIG. 1.

[0021] FIG. 5 is a left-side view of the push-button switch of FIG. 1.

[0022] FIG. 6 is a plan view of the push-button switch of FIG. 1.

[0023] FIG. 7 is a bottom view of the push-button switch of FIG. 1.

[0024] FIG. 8 is a sectional view taken along a line VIII-VIII in FIG. 1.

[0025] FIG. 9 is a front view of an operation unit of the push-button switch of FIG. 1.

[0026] FIG. 10 is a bottom view of the operation unit and a lock lever unit of the push-button switch of FIG. 1.

[0027] FIG. 11 is a perspective view showing an exterior portion of the push-button switch of FIG. 1.

[0028] FIG. 12 is a top view of a lever portion of the push-button switch of FIG. 1.

[0029] FIG. 13 is a perspective view of the push-button switch of FIG. 1 with a part of housing and an operation unit made transparent.

[0030] FIG. 14 is a right-side view of the lever portion of the push-button switch of FIG. 1.

[0031] FIG. 15 is a perspective view of a plunger of the push-button switch of FIG. 1.

[0032] FIG. 16 is a perspective view of a first plunger of the push-button switch of FIG. 1.

[0033] FIG. 17 is a perspective view of a second plunger of the push-button switch of FIG. 1.

[0034] FIG. 18 is a perspective view of the lever portion and the plunger of the push-button switch of FIG. 1.

[0035] FIG. 19 is a first plan view for explaining the operation of a transmission mechanism of the push-button switch of FIG. 1, as viewed from an arrow A direction in FIG. 18.

[0036] FIG. 20 is a second plan view for explaining the operation of the transmission mechanism of the push-button switch of FIG. 1, as viewed from the arrow A direction in FIG. 18.

[0037] FIG. 21 is a perspective view showing a second plunger, a contact mechanism, and a terminal connection mechanism of the push-button switch of FIG. 1.

[0038] FIG. 22 is a first plan view for explaining the operation of the contact mechanism of the push-button switch of FIG. 1.

[0039] FIG. 23 is a second plan view for explaining the operation of the contact mechanism of the push-button switch of FIG. 1.

[0040] FIG. 24 is a sectional view taken along a line XXIV-XXIV in FIG. 1.

[0041] FIG. 25 is a first front view for explaining the operation of a lever body using a jig of the push-button switch of FIG. 1.

[0042] FIG. 26 is a second front view for explaining the operation of the lever body using the jig of the push-button switch of FIG. 1.

[0043] FIG. 27 is a view for explaining a first modification of a fulcrum projection of the push-button switch of FIG. 1.

[0044] FIG. 28 is a view for explaining a second modification of the fulcrum projection of the push-button switch of FIG. 1.

[0045] FIG. 29 is a view for explaining a third modification of the fulcrum projection of the push-button switch of FIG. 1.

DESCRIPTION OF EMBODIMENTS

[0046] Hereinafter, an example of the present disclosure will be described with reference to the accompanying drawings. In the following description, terms indicating a specific direction or position (for example, terms including “up”, “down”, “right”, “left”) will be used as necessary. However, they are used for facilitating understanding of the present disclosure with reference to the drawings, and the technical scope of the present disclosure is not limited by the meaning of those terms. It should be noted that the following description is merely exemplary in nature and is not intended to limit the present disclosure, its application, or its use. Furthermore, the drawings are schematic, and the ratios of the dimensions do not always match actual ones.

[0047] As shown in FIGS. 1 to 7, a push-button switch 1 according to an embodiment of the present disclosure includes a substantially cubic housing 10, an operation unit 20 attached to the housing 10, and a lock lever unit 30 provided so as to be exposed to an outside of the housing 10.

[0048] The housing 10 has an operation surface 12 on which an operation hole 13 is provided. The operation hole 13 has, for example, a substantially circular shape. The operation unit 20 extends from the outside to the inside of the housing through the operation hole 13 in a movable direction (hereinafter, simply referred to as a movable direction) intersecting (for example, orthogonally) with the operation surface 12, and one end thereof in the extending direction is positioned inside the housing 10 and is attached to the housing 10 in a movable state along the movable direction. Further, the lock lever unit 30 is disposed at an edge of the operation surface 12 of the housing 10.

[0049] As shown in FIG. 8, a housing portion 11 connected to the operation hole 13 is provided inside the housing 10. That is, one end of the operation unit 20 in the

extending direction is disposed inside the housing portion 11. Inside the housing portion 11, a plunger 40 having a first plunger 41 and a second plunger 42, a transmission mechanism 50 (shown in FIGS. 19 and 20), a contact mechanism 60, and a biasing portion 70 are provided.

[0050] The plunger 40 is disposed at an end of the housing portion 11 on the operation surface 12 side in the movable direction, and the biasing portion 70 is disposed at an end of the housing portion 11 on the terminal connection surface 14 side facing the operation surface 12 in the movable direction. In addition, the transmission mechanism 50 and the contact mechanism 60 are arranged between the plunger 40 and the biasing portion 70.

[0051] Subsequently, each configuration of the push-button switch 1 will be described.

[0052] As shown in FIGS. 1 and 2, the housing 10 has the terminal connection surface 14 facing the operation surface 12 and four side surfaces extending in a direction intersecting the operation surface 12 and the terminal connection surface 14 (e.g., an orthogonal direction), and one of the four side surfaces constitutes a fulcrum forming surface 15.

[0053] The fulcrum forming surface 15 is provided with a fulcrum projection 151 protruding from the fulcrum forming surface 15 toward the outside of the housing 10 in a direction intersecting with the fulcrum forming surface 15 (for example, an orthogonal direction). As shown in FIG. 3, the fulcrum projection 151 has an oval shape extending in a direction orthogonal to the movable direction when viewed from a direction orthogonal to the fulcrum forming surface 15 and is disposed in the middle between the operation surface 12 and the terminal connection surface 14 and at one side of the center of the fulcrum forming surface 15 in a direction orthogonal to the movable direction.

[0054] Specifically, the fulcrum projection 151 is, when viewed from a direction orthogonal to the fulcrum forming surface 15, disposed closer to a first position P1 than a center line CL (see FIGS. 25 and 26) extending in the movable direction of the operation unit 20 passing through the center between the first position P1 and a second position P2 in a moving direction of the lever body 31.

[0055] The fulcrum projection 151 is configured such that one curved surface 152 in an extending direction thereof, when the lever body 31 of the lock lever unit 30 described later is moved from the first position P1 to the second position P2 using a long jig 100 (see FIGS. 25 and 26), comes into contact with an intermediate portion 102 of the jig 100 in which a distal end 101, which is one end of the jig 100, is locked to a locking portion 312 of the lock lever unit 30 described later, and serves as a rotation fulcrum of the jig 100. That is, the curved surface 152 is provided at a portion that comes into contact with the intermediate portion 102 of the jig 100, and protrudes from the fulcrum projection 151 toward the jig 100.

[0056] As shown in FIG. 7, the terminal connection surface 14 is provided with a plurality of openings 141. Each of the openings 141 is configured so that, for example, a conductor portion of an electric wire (not shown) can be inserted therein, and is connected to a terminal connection mechanism 16 provided inside the housing portion 11 as shown in FIG. 8. As an example, the terminal connection mechanism 16 employs a so-called push-in connection type, and is configured so that the conductor of the electric wire

can be connected to the push-button switch 1 simply by inserting the conductor of the electric wire from the opening 141.

[0057] As shown in FIG. 1, the operation unit 20 has a substantially cylindrical shape and has a pressing surface 21 provided outside the housing 10 and disposed so as to face the operation surface 12. The operation unit 20 is configured to be able to perform an approaching operation in which the pressing surface 21 approaches the operation surface 12 along the movable direction, and is configured so that the plunger 40 is positioned at a later-described return position P3 (see FIG. 19) by this approaching operation. Specifically, when the plunger 40 is at the non-return position other than the return position P3 (specifically, when the second plunger 42 is at a non-return position other than the return position P32), an end 22 of the operation unit 20 on the housing portion 11 side moves from an initial position (shown in FIG. 8) to a pressing position, and the operation unit 20 moves the plunger 40 along the movable direction to the return position P3 (specifically, moves the second plunger 42 along the movable direction to the return position P32).

[0058] As shown in FIGS. 1 and 6, the pressing surface 21 is provided with a display portion 25 that indicates the rotation direction of the operation unit 20 when the operation unit 20 is attached to the housing 10. The display portion 25 is configured by a clockwise arrow when viewed from an approaching direction in which the pressing surface 21 approaches the operation surface 12 in the movable direction (hereinafter, simply referred to as an approaching direction).

[0059] As shown in FIG. 9, a first groove 23 extending in the movable direction and a second groove 24 connected to an end 231 of the first groove 23 on the pressing surface 21 side in the movable direction and extending in the circumferential direction of an end 22 of the operation unit 20 on the housing portion 11 side are provided on an outer circumferential surface of the end 22 of the operation unit 20 on the housing portion 11 side. The first groove 23 and the second groove 24 are configured to be capable of housing a locking projection 342 provided on the lock lever unit 30 described later. Further, when the lever body 31 is positioned at the first position P1, the first groove 23 is capable of housing the locking projection 342, and the second groove 24 is, as shown in FIG. 10, configured to be capable of locking the locking projection 342 in the movable direction, when the lever body 31 is at the second position P2.

[0060] The locking projection 342 of the lock lever unit 30 and the first groove 23 and the second groove 24 of the operation unit 20 constitute a movement regulating portion 80. When the lever body 31 is positioned at the first position P1, the movement regulating portion 80 enables movement of the lever body 31 to the second position P2 when the end 22 of the operation unit 20 on the housing portion 11 side is positioned at the initial position (that is, as shown in FIG. 9, a position of the end 22 of the operation unit 20 on the housing portion 11 side when the locking projection 342 is positioned at the end 231 of the first groove 23 on the pressing surface 21 side in the movable direction), but it disables movement by regulating movement of the lever body 31 to the second position P2 when the end 22 of the operation unit 20 on the housing portion 11 side is positioned closer to the operation surface 12 than the initial position in the movable direction. When the end 22 of the operation unit 20 on the housing portion 11 side is positioned at the initial

position, the first groove 23 and the second groove 24 are connected so that the operation unit 20 can be rotated only in one direction (in this embodiment, the arrow direction of the display portion 25). That is, the movement regulating portion 80 is provided between the operation unit 20 and the lock lever unit 30 inside the housing portion 11, and can confirm whether or not the operation unit 20 has been securely attached to the housing 10 depending on whether or not the lever body 31 can be moved to the second position P2.

[0061] In addition, on the outer circumferential surface of the end 22 of the operation unit 20 on the housing portion 11 side, a display portion 25 (in this embodiment, an arrow in a direction from the pressing surface 21 toward the end 22 on the housing portion 11 side in the movable direction) indicating the mounting direction of the operation unit 20 to the housing 10 is provided.

[0062] As shown in FIG. 1, the lock lever unit 30 includes a lever portion 301 and an exterior portion 32 fixed to the housing 10 so as to cover the lever portion 301. As shown in FIG. 13, the lever portion 301 has the lever body 31 exposed to the outside of the housing 10, and a lever support portion 34 disposed in the housing portion 11.

[0063] As shown in FIG. 7, the lever body 31 intersects (e.g., orthogonally) with the fulcrum forming surface 15 from the fulcrum forming surface 15 and protrudes in a direction away from the fulcrum forming surface 15, and as shown in FIG. 3, is disposed between the pressing surface 21 and the operation surface 12 in the movable direction. When viewed from a direction orthogonal to the fulcrum forming surface 15, the lever body 31 is configured to be movable in a direction (for example, the orthogonal direction) intersecting the movable direction between the first position P1 (see FIG. 24) and the second position P2 (see FIG. 25).

[0064] As shown in FIGS. 6 and 7, the exterior portion 32 includes a first wall portion 321 that faces an upper surface (that is, a surface on the opposite side in the movable direction of a facing surface 311 (shown only in FIG. 7) facing the operation surface 12 of the lever body 31) in the movable direction of the lever body 31 and extends in the moving direction of the lever body 31, and a second wall portion 322 and a third wall portion 323 respectively arranged on both sides of the lever body 31 in a direction orthogonal to the movable direction (that is, the moving direction of the lever body 31) and respectively connected to the first wall portion 321 and the operation surface 12 of the housing 10. The moving range of the lever body 31 is defined by the exterior portion 32.

[0065] As shown in FIG. 6, a holding unit 33 capable of holding the lever body 31 at the second position P2 is provided at one end (that is, the right end in FIG. 6) of the first wall portion 321 in the extending direction. Specifically, as shown in FIG. 11, the holding unit 33 has an elastic holding portion 331 capable of holding the lever body 31 by pressing the lever body 31 from one side to the other side (that is, from an upper side to a lower side in FIG. 11) in the movable direction at the second position P2. The elastic holding portion 331 extends in the extending direction of the first wall portion 321, an end 332 on the other end side (that is, the left side in FIG. 11) thereof in the extending direction of the first wall portion 321 is connected to the first wall portion 321, and an end 333 on one end side thereof in the extending direction of the first wall portion 321 is disposed between the first wall portion 321 and the operation surface

12 and configured to be elastically deformable in a direction away from the operation surface 12 in the movable direction.

[0066] Further, as shown in FIG. 11, a display portion 37 is provided on the first position P1 side (that is, the left side in FIG. 11) of the surface of the first wall portion 321 facing the operation surface 12. The display portion 37 is composed of characters "UNLOCK" and arrows indicating the direction from the second position P2 toward the first position P1.

[0067] As shown in FIG. 7, a locking portion 312 and a hold releasing portion 313 are provided on the facing surface 311 of the lever body 31. The locking portion 312 is configured to be capable of locking a distal end 101 (see FIGS. 25 and 26) which is one end in the extending direction of the long jig 100 used for moving the lever body 31 from the first position P1 to the second position P2. Further, the hold releasing portion 313 is configured to be capable of releasing holding of the lever body 31 by the elastic holding portion 331 by pressing the lever body 31 from the other side to one side (that is, from the near side to the back in the paper penetration direction in FIG. 7) in the movable direction at the second position P2.

[0068] Further, the lever body 31 is provided with a protection wall 314 that is disposed on the opposite side (that is, on the upper side in FIG. 7) of the fulcrum forming surface 15 with respect to the hold releasing portion 313 in a direction intersecting with the fulcrum forming surface 15 and protects the hold releasing portion 313 in the direction intersecting with the fulcrum forming surface 15.

[0069] Further, as shown in FIG. 12, the lock lever unit 30 has the lever support portion 34 connected to the lever body 31 so as to be movable together with the lever body 31. As shown in FIG. 13, the lever support portion 34 is provided inside the housing portion 11 to surround the end 22 of the operation unit 20 on the housing portion 11 side in the circumferential direction (that is, around the movable direction), and is disposed so that an inner circumferential surface 341 of the lever support portion 34 faces the end 22 of the operation unit 20 on the housing portion 11 side.

[0070] As shown in FIG. 12, the lever support portion 34 is provided with the locking projection 342 that protrudes from the inner circumferential surface 341 toward the operation unit 20 (that is, toward the radial inside of the lever support portion 34). In this embodiment, as an example, four locking projections 342 are arranged at intervals in the circumferential direction of the inner circumferential surface 341 of the lever support portion 34.

[0071] In addition, as shown in FIG. 14, the lever support portion 34 includes a lever connection portion 345, which is an example of a connection portion, and an inclined portion 346.

[0072] The lever connection portion 345 has a substantially annular shape, extends along the operation surface 12, and houses the end 22 of the housing portion 11 of the operation unit 20 in a substantially circular through hole 344 at the center thereof. That is, the lever body 31 rotates around a rotation axis that passes through the center of the lever connection portion 345 and extends in the movable direction. Further, the lever connection portion 345 is connected to the operation unit 20 in a movable state in the movable direction together with the operation unit 20 when the lever body 31 is at the second position P2. The inclined portion 346 is connected to the lever connection portion 345 and the lever body 31, and is inclined from the lever connection portion 345 toward the lever body 31 in an

opening direction from the operation surface 12 toward the pressing surface 21 (hereinafter simply referred to as an opening direction) along the movable direction.

[0073] The lever connection portion 345 is provided with a plurality of cam projections 343 (in this embodiment, as an example, two cam projections 343) protruding radially outward from the outer circumferential surface of the lever support portion 34. Specifically, the cam projections 343 are provided respectively on the outer circumferential surfaces 351 of a pair of legs 35 extending from the edge of the through hole 344 of the lever connection portion 345 along the movable direction in the direction away from the operation surface 12. Further, each cam projection 343 has a quadrangular shape in which all corners are chamfered when viewed from the protruding direction. Each leg 35 is disposed on the same straight line passing through a center CP (shown in FIG. 12) of the through hole 344, and each cam projection 343 is configured so as to be engageable with each of a plurality of cam grooves 412 of the first plunger 41 described later.

[0074] Note that the transmission mechanism 50 is configured by the lever support portion 34, the plurality of cam projections 343, and the plurality of cam grooves 412. That is, the transmission mechanism 50 is disposed between the lock lever unit 30 and the plunger 40.

[0075] As shown in FIG. 3, the lever body 31 is provided with a display portion 36 on an exposed side surface that is not covered by the exterior portion 32 when viewed from a direction orthogonal to the fulcrum forming surface 15. The display portion 36 is composed of characters "LOCK" and arrows indicating the direction from the first position P1 to the second position P2.

[0076] As shown in FIG. 8, the plunger 40 is disposed at the end on the operation surface 12 side inside the housing portion 11, and is configured to be movable along the movable direction between a return position P3 (see FIG. 19) away from the operation surface 12 and an operating position (see FIG. 20) in the middle of the operation surface 12 and the return position P3. More specifically, as shown in FIG. 15, the plunger 40 has the first plunger 41 in a substantially rectangular plate shape and the second plunger 42 disposed in series with the first plunger 41 along the movable direction and disposed away from the operation surface 12. The first plunger 41 and the second plunger 42 are not connected and are configured to be movable independently of each other.

[0077] As shown in FIG. 16, the first plunger 41 has a substantially circular through hole 411 provided at a substantially central portion and penetrating in a movable direction and a plurality of cam grooves (in this embodiment, as an example, two cam grooves) 412 provided on an inner circumferential surface 414 and mutually arranged at intervals (for example, at 180 degrees) in the circumferential direction of the inner circumferential surface 414. In the through hole 411, as shown in FIG. 13, the end 22 of the operation unit 20 on the housing portion 11 side is housed so as to be rotatable in the circumferential direction (that is, around the movable direction) of the inner circumferential surface 414.

[0078] Each cam groove 412, as viewed from the approaching direction, is inclined in a direction approaching the operation surface 12 (in other words, so as to be away from the operation surface 12 along the moving direction from the first position P1 toward the second position P2 of

the lever body 31) as it advances in a clockwise direction along the circumferential direction of the inner circumferential surface 414 of the through hole 411, and is disposed so as to be engageable with each cam projection 343 of the lever support portion 34 of the lock lever unit 30. In other words, the inner circumferential surface 414 of the through hole 411 faces the outer circumferential surface 351 of each leg 35 of the lever support portion 34, and each cam groove 412 corresponds to each cam projection 343. Further, at each corner of the first plunger 41, a circular recess 413 is provided. As shown in FIG. 13, a coil spring 71 is housed in each recess 413.

[0079] As shown in FIG. 17, the second plunger 42 is provided with an annular main body 421 having a through hole 423 provided in the center, and a plurality of plunger connection portions (in this embodiment, as an example, four plunger connection portions) 422 provided radially outside the main body 421.

[0080] The main body 421 is provided with an annular wall 424 protruding in a direction approaching the operation surface 12 from the peripheral portion of the through hole 423 at the center thereof along the movable direction (that is, upward in FIG. 17). The annular wall 424 is configured to be insertable into the through hole 411 of the first plunger 41. A partially annular recess 425 for housing the end 22 of the operation unit 20 on the housing portion 11 side is formed radially outside the annular wall 424 of the main body 421.

[0081] The plunger connection portions 422 are arranged at intervals along the circumferential direction of the outer circumferential surface of the main body 421. Each plunger connection portion 422 has a substantially rectangular parallelepiped shape extending from the main body 421 along the movable direction in a direction away from the operation surface 12 (that is, downward in FIG. 17), and is connected to the contact mechanism 60.

[0082] An LED unit 90 is disposed in the through hole 423 of the second plunger 42, as shown in FIG. 13.

[0083] FIGS. 18 to 20 show a state in which the lock lever unit 30 and the plunger 40 are connected. FIG. 19 is a plan view showing a state in which the lever body 31 is at the first position P1 and the plunger 40 is at the return position P3 as viewed from the direction indicated by the arrow A in FIG. 18, and FIG. 20 is a plan view showing a state in which the lever body 31 is at the second position P2 and the plunger 40 is at the operating position P4 as viewed from the direction indicated by the arrow A in FIG. 18.

[0084] As shown in FIGS. 19 and 20, the first plunger 41 is configured to move from the return position P31 to the operating position P41 when the lever body 31 is moved from the first position P1 to the second position P2 by the transmission mechanism 50, and move from the operating position P41 to the return position P31 when the lever body 31 is moved from the second position P2 to the first position P1. The second plunger 42 is biased by a coil spring 72 described later in a direction approaching the operation surface 12 along the movable direction. Therefore, the second plunger 42 moves from the return position P32 to the operating position P42 with the movement of the first plunger 41 from the return position P3 to the operating position P4, and moves from the operating position P42 to the return position P32 with the movement of the first plunger 41 from the operating position P4 to the return position P3. When the second plunger 42 is not positioned at the return position P32, the second plunger 42 is config-

ured to be movable to the return position P32 along the movable direction by the approaching operation of the operation unit 20. That is, the second plunger 42 is configured to be positioned at the return position P32 by the approaching operation of the operation unit 20. Note that, the second plunger 42, when having moved to the return position P32 due to the approaching operation of the operation unit 20, is held at the return position P32 by the end 22 of the operation unit 20 on the housing portion 11 side.

[0085] That is, the transmission mechanism 50 moves the plunger 40 from the return position P3 to the operating position P4 along the movable direction as the lever body 31 moves from the first position P1 toward the second position P2, but it moves the plunger 40 from the operating position P4 to the return position P3 along the movable direction as the lever body 31 moves from the second position P2 toward the first position P1. In other words, the transmission mechanism 50 has a function of transmitting the moving operation of the lever body 31 to the plunger 40.

[0086] As shown in FIG. 21, the contact mechanism 60 includes a plurality of fixed contact portions 61 provided inside the housing portion 11 and a plurality of movable contact portions 62 provided respectively so as to face the fixed contact portions 61 in the movable direction inside the housing portion 11. The fixed contact portions 61 are connected to the terminal connection mechanisms 16, respectively. Each movable contact portion 62 is connected to any one of the four plunger connection portions 422 of the second plunger 42, and is configured to contact the facing fixed contact portion 61 by movement of the second plunger 42 from the return position P32 to the operating position P42 and separate from the fixed contact portion 61 in contact by movement of the second plunger 42 from the operating position P42 to the return position P32. In other words, the contact mechanism 60 is configured to be opened and closed by the movement of the second plunger 42 along the movable direction.

[0087] In more detail, the terminal connection mechanisms 16 are arranged in a line along the fulcrum forming surface 15 and the surface facing the fulcrum forming surface 15. The fixed contact portion 61 connected to the terminal connection mechanism 16 (hereinafter, referred to as a first terminal connection mechanism 161) disposed along the fulcrum forming surface 15 and the facing movable contact portion 62 constitute an NO contact 63, and the fixed contact portion 61 connected to the terminal connection mechanism 16 (hereinafter, referred to as a second terminal connection mechanism 162) disposed along the surface facing the fulcrum forming surface 15 and the facing movable contact portion 62 constitute an NC contact 64. That is, when the lever body 31 is at the first position P1, as shown in FIG. 22, the NO contact 63 is closed and the NC contact 64 is opened, while when the lever body 31 is at the second position P2, as shown in FIG. 23, the NO contact 63 is opened and the NC contact 64 is closed.

[0088] The biasing portion 70 has a coil spring 71 (shown in FIG. 13) as an example of a first biasing portion and a coil spring 72 (shown in FIG. 8) as an example of a second biasing portion.

[0089] As shown in FIG. 13, the coil springs 71 are respectively arranged in the recesses 413 provided at the four corners of the first plunger 41 inside the housing portion 11, and bias the plunger 40 from the operating position P4 along the movable direction toward the return position P3.

Specifically, the respective coil springs 71 are arranged in a state in which they are sandwiched between a bottom surface of the recess 413 of the first plunger 41 and an inner surface 111 (see FIG. 24) constituting the housing portion 11 of the housing 10 facing the bottom surface, press the first plunger 41 in a direction away from the operation surface 12 along the movable direction, and bias the first plunger 41 from the operating position P41 toward the return position P31. That is, the respective coil springs 71 are arranged so that the pressing on the first plunger 41 is even and bias the lever body 31 of the lock lever unit 30 from the second position P2 toward the first position P1 via the first plunger 41.

[0090] As shown in FIG. 8, the coil spring 72 is disposed between the terminal connection surface 14 and the contact mechanism 60 along the movable direction inside the housing portion 11, and biases the plunger 40 along the movable direction from the return position P3 toward the operating position P4. More specifically, the coil spring 72 is disposed on a center line CL extending in the movable direction of the operation unit 20, and is disposed in a state in which it presses a portion of the contact mechanism 60 facing the terminal connection surface 14 toward the operation surface 12 and biases the second plunger 42 along the movable direction from the return position P32 toward the operating position P42 via the contact mechanism 60.

[0091] The coil spring 71 is configured so that the biasing force thereof is greater than the biasing force of the coil spring 72. As a result, as long as the lever body 31 is not operated, the plunger 40 is always positioned at the return position P3 and maintains a state in which the movable contact portion 62 of the NC contact 64 is separated from the fixed contact portion 61, and thus the safety of the push-button switch 1 is ensured.

[0092] Next, referring to FIG. 24, when the lever body 31 of the lock lever unit 30 is positioned at the second position P2, the operation of the push-button switch 1 when the operation unit 20 is pulled from the operation surface 12 toward the pressing surface 21 along the movable direction (that is, in the opening direction indicated by the arrow B in FIG. 24) will be described.

[0093] As shown in FIG. 24, a deformation portion 17 connected to the exterior portion 32 of the lock lever unit 30 and extending along the inclined portion 346 of the lever support portion 34 is provided on a wall 18 on the operation surface 12 side of the housing 10.

[0094] When the lever body 31 of the lock lever unit 30 is positioned at the second position P2, the end 22 of the operation unit 20 on the housing portion 11 side and the lever support portion 34 of the lock lever unit 30 are movably connected together in the movable direction. Therefore, when the operation unit 20 is pulled in the opening direction, the lever support portion 34 is also pulled together in the opening direction.

[0095] When the lever support portion 34 is pulled in the opening direction, the inclined portion 346 of the lever support portion 34 moves toward the operation unit 20 and comes into contact with the deformation portion 17 of the housing 10. The inclined portion 346 in contact with the deformation portion 17 is deformed in the approaching direction, moves the lever body 31 in the approaching direction, and releases the pressing to the lever body 31 by the holding unit 33. When the pressing to the lever body 31 by the holding unit 33 is released, the lever body 31 moves

from the second position P2 to the first position P1 by the coil spring 71, and the movable contact portion 62 of the NC contact 64 is separated from the corresponding fixed contact portion 61.

[0096] Subsequently, the operation of the lever body 31 using the jig 100 will be described with reference to FIGS. 25 and 26.

[0097] First, as shown in FIG. 25, the distal end 101 of the jig 100 is locked to the locking portion 312 of the lever body 31 at the first position P1. At this time, the jig 100 is disposed so that the intermediate portion 102 thereof contacts the curved surface 152 of the fulcrum projection 151.

[0098] Then, the jig 100 is rotated clockwise in FIG. 25 while the distal end 101 is locked to the locking portion 312 with the curved surface 152 of the fulcrum projection 151 contacting the intermediate portion 102 of the jig 100 as a rotation fulcrum. As a result, the lever body 31 moves from the first position P1 to the second position P2, as shown in FIG. 26.

[0099] As described above, in the push-button switch 1, it is possible to move the lever body 31 from the first position P1 to the second position P2 using the jig 100.

[0100] As described above, according to the push-button switch 1, the plunger 40 has the first plunger 41 that can move between the return position P3 and the operating position P4 by the transmission mechanism 50 of the lock lever unit 30, and the second plunger 42 that is disposed in series with respect to the first plunger 41 and disposed farther away from the operation surface 12 than the first plunger 41, and can move to the return position P3 by the operation unit 20. The first plunger 41 and the second plunger 42 can move independently of each other, and are configured so that the movable contact portion 62 contacts with or separates from the fixed contact portion 61 by the movement of the second plunger 42. That is, in the push-button switch 1, it is possible to ensure the contact reliability of the movable contact portion 62 with respect to the fixed contact portion 61 by merely ensuring the positional accuracy of the second plunger 42 and the contact mechanism 50 without being affected by the securement of the positional accuracy of the lock lever unit 30. For this reason, for example, the contact reliability of the fixed contact portion 61 and the movable contact portion 62 can be ensured more easily than that of the operation switch of PTL 1 in which the positional accuracy of the lock lever, the cam, the holder, and the contact B needs to be ensured.

[0101] Further, the first plunger 41 has the through hole 411 that penetrates in the movable direction and a plurality of cam grooves 412 which are provided on the inner circumferential surface 414 of the through hole 411 and arranged at an interval from each other in the circumferential direction of the inner circumferential surface 414, and which are respectively inclined so as to be away from the operation surface 12 along the moving direction of the lever body 31 from the first position P1 toward the second position P2, and the lock lever unit 30 has the lever support portion 34 which is disposed in the through hole 411 and extends along the inner circumferential surface 414 of the through hole 411 and a plurality of cam projections 343 which are provided so as to respectively correspond to the plurality of cam grooves 412 and which protrude from the outer circumferential surface 351 facing the inner circumferential surface 414 of the lever support portion 34 and respectively engage with the corresponding plurality of cam grooves 412. The trans-

mission mechanism 50 includes a plurality of cam grooves 412, a lever support portion 34, and a plurality of cam projections 343. The transmission mechanism 50 can move the entire plunger 40 more reliably along the movable direction, so that the contact reliability of the fixed contact portion 61 and the movable contact portion 62 can be ensured.

[0102] According to the push-button switch 1, the lever body 31 of the lock lever unit 30 has the locking portion 312 that can lock the one end 101 of the long jig 100 in the extending direction thereof, and the housing 10 has a fulcrum projection 151 that contacts the intermediate portion 102 of the jig 100 in which one end 101 is locked to the locking portion 312 when the lever body 31 of the lock lever unit 30 is moved from the first position P1 to the second position P2 using the jig 100, and serves as a rotation fulcrum of the jig 100. Due to the locking portion 312 and the fulcrum projection 151, even when, for example, a large force is required for the rotation operation of the lever body 31 of the lock lever unit 30, the leverage principle is generated by using the jig 100, and the lever body 31 of the lock lever unit 30 can be easily rotated with a smaller force.

[0103] The holding unit 33 has an elastic holding portion 331 capable of holding the lever body 31 by pressing the lever body 31 from one side to the other side in the movable direction at the second position P2 and a hold releasing portion 313 capable of releasing the holding of the lever body 31 by the elastic holding portion 331 by pressing the lever body 31 from the other side to one side in the movable direction at the second position P2. With the elastic holding portion 331 and the hold releasing portion 313, the lever body 31 can be held at the second position P2, and the holding of the lever body 31 by the elastic holding portion 331 can be released with a simpler configuration.

[0104] Further, the lever body 31 has a protection wall 314 disposed on the opposite side of the fulcrum forming surface 15 with respect to the hold releasing portion 313 in the direction intersecting the fulcrum forming surface 15 and protecting the hold releasing portion 313 in the direction intersecting the fulcrum forming surface 15. The protection wall 314 can reduce erroneous operation of the hold releasing portion 313.

[0105] The fulcrum projection 151 has a curved surface 152 provided at a portion in contact with the intermediate portion 102 of the jig 100 and protruding from the fulcrum projection 151 toward the jig 100. Due to the curved surface 152, the rotation fulcrum of the jig 100 becomes constant, and the lever body 31 can be operated more easily by using the jig 100.

[0106] Further, the fulcrum projection 151 is disposed closer to the first position P1 than the center between the first position P1 and the second position P2 in the moving direction of the lever body 31 when viewed from a direction orthogonal to the fulcrum forming surface 15. Thus, the lever body 31 can be operated more easily by using the jig 100.

[0107] According to the push-button switch 1, the housing 10 has a deformation portion 17 that, when the operation unit 20 is pulled in the opening direction in which it is separated from the housing 10 when the lever body 31 is positioned at the second position P2, contacts the lever support portion 34 to move the lever body 31, and deforms the lever body 31 so as to be capable of releasing the pressing to the lever body 31 by the holding unit 33. Due to

this deformation portion 17, when the lever body 31 is held by the holding unit 33 in a state in which the lever body 31 is at the second position P2 and the movable contact portion 62 is in contact with the fixed contact portion 61, even if the operation unit 20 is pulled in the opening direction in which it is separated from the housing 10, since the holding of the lever body 31 by the holding unit 33 can be released, and the movable contact portion 62 can be separated from the fixed contact portion 61, it is possible to realize the push-button switch 1 capable of easily ensuring safety.

[0108] Further, the lever body 31 is disposed between the pressing surface 21 and the operation surface 12 in the movable direction, and the lever support portion 34 has the lever connection portion 345 that extends along the operation surface 12 and is connected to the operation unit 20 so as to be movable in the movable direction together with the operation unit 20 when the lever body 31 is at the second position P2, and the inclined portion 346 that is connected to the lever connection portion 345 and the lever body 31 and is inclined in the opening direction from the lever connection portion 345 toward the lever body 31. In addition, the deformation portion 17 is disposed facing the inclined portion 346 and capable of contacting the inclined portion 346, and when the operation unit 20 is pulled in the opening direction, the deformation portion 17 contacts the inclined portion 346 to move the lever body 31 in the approaching direction and deforms the lever body 31 so as to be capable of releasing the pressing to the lever body 31 by the holding unit 33. Accordingly, when the lever body 31 is held by the holding unit 33 in a state in which the lever body 31 is at the second position P2 and the movable contact portion 62 is in contact with the fixed contact portion 61, even if the operation unit 20 is pulled in the opening direction in which it is separated from the housing 10, the holding of the lever body 31 by the holding unit 33 can be released more reliably, and the movable contact portion 62 can be separated from the fixed contact portion 61.

[0109] According to the push-button switch 1, it includes a lock lever unit 30 having a lever body 31 movable between a first position P1 and a second position P2 and a holding unit 33 capable of holding the lever body 31 at the second position P2, a transmission mechanism 50 that moves the plunger 40 from the return position P3 to the operating position P4 as the lever body 31 moves from the first position P1 toward the second position P2, but moves the plunger 40 from the operating position P4 to the return position P3 as the lever body 31 moves from the second position P2 toward the first position P1, a movement regulating portion 80 that, when the lever body 31 is positioned at the first position P1, enables movement of the lever body 31 to the second position P2 when the end 22 of the operation unit 20 on the housing portion 11 side is positioned at an initial position, but disables movement of the lever body 31 to the second position P2 when the end 22 of the operation unit 20 on the housing portion 11 side is positioned closer to the operation surface 12 than the initial position, and a coil spring 71 that biases the plunger 40 from the operating position P4 toward the return position P3. That is, in the push-button switch 1, for example, when the operation unit 20 once removed for maintenance or the like is attached to the housing 10, when the end 22 of the operation unit 20 on the housing portion 11 side is positioned at the initial position, the lever body 31 can be moved to the second position P2 and held by the holding unit 33, but when the

end 22 of the operation unit 20 on the housing portion 11 side is positioned closer to the operation surface 12 than the initial position in the movable direction, the lever body 31 cannot be moved to the second position P2, and the lever body 31 is biased by the first biasing portion 71 via the plunger 40 to move to the first position P1. This makes it possible to realize a push-button switch 1 to which the operation unit 20 can be reliably attached in a complete state.

[0110] Further, a coil spring 72 that is provided inside the housing portion 11 and biases the plunger 40 from the return position P3 toward the operating position P4 along the movable direction is further provided, and is configured so that the biasing force of the coil spring 71 is greater than the biasing force of the coil spring 72. The plunger 40 has a first plunger 41 that is disposed so as to be able to be biased by the coil spring 71, and is movable along the movable direction between the return position P31 and the operating position P41 by the transmission mechanism 50 as the lever body 31 moves between the first position P1 and the second position P2, and a second plunger 42 that is disposed farther away from the operation surface 12 along the movable direction than the first plunger 41 in a state capable of being biased by the coil spring 72 and disposed in series with the first plunger 41 along the movable direction, and is positioned at the return position P32 by the approaching operation of the operation unit 20. Further, the first plunger 41 and the second plunger 42 can move independently of each other along the movable direction, and are configured so that the movable contact portion 62 contacts with or separates from the fixed contact portion 61 by the movement of the second plunger 42 along the movable direction. This makes it possible to ensure the contact reliability of the movable contact portion 62 with respect to the fixed contact portion 61 by merely ensuring the positional accuracy of the second plunger 42 and the contact mechanism 50 without being affected by the securement of the positional accuracy of the lock lever unit 30.

[0111] Further, the first plunger 41 has a through hole 411 that penetrates in the movable direction and a plurality of cam grooves 412 which are provided on the inner circumferential surface 414 of the through hole 411 and are arranged at an interval from each other in the circumferential direction of the inner circumferential surface 414 and which are respectively inclined away from the operation surface 12 along the moving direction of the lever body 31 from the first position P1 toward the second position P2, and the lever support portion 34 has a plurality of cam projections 343 which are arranged in the through hole 411 and extend along the inner circumferential surface 414 of the through hole 411 and which are provided so as to respectively correspond to the plurality of cam grooves 412, protrude from the outer circumferential surface 351 facing the inner circumferential surface 414 of the lever support portion 34 toward the inner circumferential surface 414, and respectively engage with the corresponding plurality of cam grooves 412. The transmission mechanism 50 includes a plurality of cam grooves 412, a lever support portion 34, and a plurality of cam projections 343. The transmission mechanism 50 can move the entire plunger 40 more reliably along the movable direction, so that the contact reliability of the fixed contact portion 61 and the movable contact portion 62 can be ensured.

[0112] Further, the lever support portion 34 surrounds the end 22 of the operation unit 20 on the housing portion 11 side in the circumferential direction (that is, around the movable direction), has an inner circumferential surface 341 disposed so as to face the end 22 of the operation unit 20 on the housing portion 11 side, and has a locking projection 342 protruding from the inner circumferential surface 341 toward the operation unit 20, and the end 22 of the operation unit 20 on the housing portion 11 side has a first groove 23 extending in the movable direction and capable of housing the locking projection 342 when the lever body 31 is at the first position P1 and a second groove 24 which is connected to the end 231 of the first groove 23 on the pressing surface 21 side in the movable direction and extends along the circumferential direction of the end 22 of the operation unit 20 on the housing portion 11 side so as to be capable of housing the locking projection 342 and which locks the locking projection 342 in the movable direction when the lever body 31 is at the second position P2. The movement regulating portion 80 includes the locking projection 342, the first groove 23, and the second groove 24. Accordingly, the movement of the lever body 31 to the second position can be regulated with a simple configuration, so that it is possible to easily realize the push-button switch 1 to which the operation unit 20 can be reliably attached in a complete state.

[0113] Further, the first biasing portion is configured by a plurality of coil springs 71. Thus, with a simple configuration, the plunger 40 can be biased from the operating position P4 toward the return position P3 along the movable direction.

[0114] Further, the second biasing portion is configured by at least one coil spring 72. Thereby, with a simple configuration, the plunger 40 can be biased from the return position P3 toward the operating position P4 along the movable direction.

[0115] The configuration other than the housing 10, the plunger 40, the operation unit 20, the lock lever unit 30, the transmission mechanism 50, the movement regulating portion 80, the contact mechanism 60, and the first biasing portion 71 may be omitted if possible, or may be replaced with a configuration different from the push-button switch 1. For example, the deformation portion 17 and the fulcrum projection 151 of the housing 10 may be omitted.

[0116] The transmission mechanism 50 is not limited to the case where it includes the lever support portion 34, the plurality of cam projections 343, and the plurality of cam grooves 412. The transmission mechanism 50 can adopt any configuration that can move the plunger 40 from the return position P3 to the operating position P4 as the lever body 31 moves from the first position P1 toward the second position P2, but can move the plunger 40 from the operating position P4 to the return position P3 as the lever body 31 moves from the second position P2 toward the first position P1.

[0117] The contact mechanism 60 can adopt a contact mechanism with any configuration as long as it includes a fixed contact portion 61 and a movable contact portion 62 that is provided so as to face the fixed contact portion 61 in the movable direction, contacts the fixed contact portion 61 when the plunger 40 moves from the return position P3 to the operating position P4, and separates from the fixed contact portion 61 when the plunger 40 moves from the operating position P4 to the return position P3.

[0118] The lever connection portion 345 of the lever support portion 34 is not limited to a substantially annular shape, and may be, for example, a semi-circular shape.

[0119] The holding unit 33 is not limited to the case where it is configured by the elastic holding portion 331, and any configuration can be adopted as long as the lever body 31 can be held at the second position P2. Further, the hold releasing portion 313 can be appropriately changed according to the configuration of the holding unit 33.

[0120] The protection wall 314 is not limited to the case where it is provided on the lever body 31, but may be provided on the exterior portion 32, for example.

[0121] The fulcrum projection 151 is not limited to a case having an oval shape. For example, as shown in FIG. 27, it may be a fulcrum projection 151 having a curved surface 152 only on a side in contact with the intermediate portion 102 of the jig 100 in its extending direction when viewed from a direction orthogonal to the fulcrum forming surface 15. Further, as shown in FIG. 28, it may be a fulcrum projection 151 having a curved surface 152 protruding in a direction away from the jig 100 on a side in contact with the intermediate portion 102 of the jig 100 in its extending direction when viewed from a direction orthogonal to the fulcrum forming surface 15. Further, as shown in FIG. 29, it may be a fulcrum projection 151 having a through hole 153 penetrating in the movable direction. In this case, the inner circumferential surface of the through hole 153 contacts the intermediate portion 102 of the jig 100 and serves as a rotation fulcrum of the jig 100.

[0122] The first biasing portion is not limited to a case where it is configured by a plurality of coil springs 71, and can adopt a biasing portion with any configuration capable of biasing the plunger 40 from the operating position P4 toward the return position P3 along the movable direction. For example, the first biasing portion may be configured by a single or three or more coil springs 71.

[0123] The second biasing portion is not limited to a case where it is configured by a single coil spring 72, and can adopt a biasing portion with any configuration capable of biasing the plunger 40 from the return position P3 toward the operating position P4 along the movable direction. For example, the second biasing portion may be configured by a plurality of coil springs 72.

[0124] It is sufficient that the plunger 40 has a first plunger 41 and a second plunger 42 and is movable between the return position P3 and the operating position P4 along the movable direction, and its shape and the like can be changed as appropriate by the design and the like of the push-button switch 1.

[0125] It is sufficient that the deformation portion 17 is configured such that when the operation unit 20 is pulled in the opening direction in which the operation unit 20 is separated from the housing 10 while the lever body 31 is positioned at the second position P2, the deformation portion 17 contacts the lever support portion 34 to move the lever body 31, and deforms the lever body 31 so as to be capable of releasing the pressing to the lever body 31 by the holding unit 33. That is, the shape and the like of the deformation portion 17 can be appropriately changed according to the shape and the like of the lever body 31 and the lever support portion 34.

[0126] The movement regulating portion 80 is not limited to the case where it includes the locking projection 342, the first groove 23, and the second groove 24. The movement

regulating portion **80** can adopt any configuration that, when the lever body **31** is positioned at the first position **P1**, enables the movement of the lever body **31** to the second position **P2** when the end **22** of the operation unit **20** on the housing portion **11** side is positioned at the initial position, but disables the movement of the lever body **31** to the second position **P2** when the end **22** of the operation unit **20** on the housing portion **11** side is positioned closer to the operation surface **12** than the initial position.

[0127] As described above, various embodiments of the present disclosure have been described in detail with reference to the drawings, and finally, various aspects of the present disclosure will be described. In the following description, description will be provided with reference numerals attached thereto as an example.

[0128] The push-button switch **1** according to the first aspect of the present disclosure includes:

[0129] a housing **10** having an operation surface **12** provided with an operation hole **13** and a housing portion **11** provided therein and connected to the operation hole **13**;

[0130] a plunger **40** provided at an inside of the housing portion **11** and movable between a return position **P3** away from the operation surface **12** and an operating position **P4** in the middle between the operation surface **12** and the return position **P3** along a movable direction intersecting the operation surface **12**;

[0131] an operation unit **20** that extends along the movable direction from an outside of the housing **10** through the operation hole **13** to the inside of the housing portion **11** and is mounted to the housing **10** in a state in which an end **22** on the housing portion **11** side in an extending direction is positioned at an initial position, and has a pressing surface **21** provided at the outside of the housing **10** and disposed so as to face the operation surface **12**, in which the pressing surface **21** is capable of an approaching operation with respect to the operation surface **12** along the movable direction, and the end **22** on the housing portion **11** side moves from the initial position to a pressing position to position the plunger **40** at the return position **P3** by the approaching operation;

[0132] a lock lever unit **30** that has a lever body **31** exposed to the outside of the housing **10** and movable in a direction intersecting the movable direction between a first position **P1** and a second position **P2**, a lever support portion **34** provided at the inside of the housing portion **11** and connected to the lever body **31** so as to be movable together with the lever body **31**, and a holding unit **33** capable of holding the lever body **31** at the second position;

[0133] a transmission mechanism **50** that is provided between the lock lever unit **30** and the plunger **40** inside the housing portion **11**, moves the plunger **40** from the return position **P3** to the operating position **P4** along the movable direction as the lever body **31** moves from the first position **P1** toward the second position **P2**, and moves the plunger **40** from the operating position **P4** to the return position **P3** along the movable direction as the lever body **31** moves from the second position **P2** toward the first position **P1**;

[0134] a movement regulating portion **80** that is provided between the operation unit **20** and the lock lever unit **30** inside the housing portion **11**, and when the lever body **31** is positioned at the first position **P1**, enables movement of the lever body **31** to the second position **P2** when the end **22** of the operation unit **20** on the housing portion **11** side is positioned at the initial position, and disables movement of

the lever body **31** to the second position **P2** when the end **22** of the operation unit **20** on the housing portion **11** side is positioned closer to the operation surface **12** than the initial position in the movable direction;

[0135] a contact mechanism **60** that has a fixed contact portion **61** provided at the inside of the housing portion **11** and a movable contact portion **62** that is provided at the inside of the housing portion **11** so as to face the fixed contact portion **61**, comes into contact with the fixed contact portion **61** when the plunger **40** moves from the return position **P3** to the operating position **P2**, and separates from the fixed contact portion **61** when the plunger **40** moves from the operating position **P3** to the return position **P2**; and

[0136] a first biasing portion **71** provided inside the housing portion **11** and biasing the plunger **40** from the operating position **P4** toward the return position **P3** along the movable direction.

[0137] According to the push-button switch **1** of the first aspect, for example, when the operation unit **20** once removed for maintenance or the like is attached to the housing **10**, when the end **22** of the operation unit **20** on the housing portion **11** side is positioned at the initial position, the lever body **31** can be moved to the second position **P2** and held by the holding unit **33**, while when the end **22** of the operation unit **20** on the housing portion **11** side is positioned closer to the operation surface **12** than the initial position in the movable direction, the lever body **31** cannot be moved to the second position **P2**, and the lever body **31** is biased by the first biasing portion **71** via the plunger **40** to move to the first position **P1**. This makes it possible to realize a push-button switch **1** to which the operation unit **20** can be reliably attached in a complete state.

[0138] The push-button switch **1** according to the second aspect of the present disclosure further includes:

[0139] a second biasing portion **72** provided inside the housing portion **11** and biasing the plunger **40** from the return position **P3** toward the operating position **P4** along the movable direction, in which

[0140] the biasing force of the first biasing portion **71** is configured to be larger than the biasing force of the second biasing portion **72**,

[0141] the plunger **40** has

[0142] a first plunger **41** disposed capable of being biased by the first biasing portion **71** and movable along the movable direction between the return position **P3** and the operating position **P4** by the transmission mechanism **50** as the lever body **31** moves between the first position **P1** and the second position **P2**, and

[0143] a second plunger **42** that is disposed farther away from the operation surface **12** along the movable direction than the first plunger **41** in a state capable of being biased by the second biasing portion **72** and disposed in series with the first plunger **41** along the movable direction, and is positioned at the return position **P3** by the approaching operation of the operation unit **20**,

[0144] the first plunger **41** and the second plunger **42** are movable along the movable direction independently of each other, and

[0145] the movable contact portion **62** is configured to contact with or separate from the fixed contact portion **61** by movement of the second plunger **42** along the movable direction.

[0146] According to the push-button switch **1** of the second aspect, the contact reliability of the movable contact

portion **62** with respect to the fixed contact portion **61** can be ensured only by ensuring the positional accuracy of the second plunger **42** and the contact mechanism **50** without being affected by the securement of the positional accuracy of the lock lever unit **30**.

[0147] In the push-button switch **1** according to the third aspect of the present disclosure,

[0148] the first plunger **41** has

[0149] a plurality of cam grooves **412** which are provided on the inner circumferential surface **414** of the through hole **411** that penetrates in the movable direction and disposed at an interval from each other in the circumferential direction of the inner circumferential surface **414** and which are respectively inclined so as to separate from the operation surface **12** along the moving direction from the first position **P1** of the lever body **31** toward the second position **P2**,

[0150] the lever support portion **34**

[0151] is disposed in the through hole **411** and extends along the inner circumferential surface **414** of the through hole **411**, and

[0152] has a plurality of cam projections **343** which are provided so as to respectively correspond to the plurality of cam grooves **412** and protrude from the outer circumferential surface **351** facing the inner circumferential surface **414** of the lever support portion **34** toward the inner circumferential surface **414** and which respectively engage with the corresponding plurality of cam grooves **412**, and

[0153] the transmission mechanism **50** includes the plurality of cam grooves **412**, the lever support portion **34**, and the plurality of cam projections **343**.

[0154] According to the push-button switch **1** of the third aspect, the entirety of the plunger **40** can be more reliably moved along the movable direction by the transmission mechanism **50**, so that the contact reliability of the fixed contact portion **61** and the movable contact portion **62** can be ensured.

[0155] In the push-button switch **1** according to the fourth aspect of the present disclosure,

[0156] the second biasing portion is configured by at least one coil spring.

[0157] According to the push-button switch **1** of the fourth aspect, the plunger **40** can be biased from the operating position **P4** toward the return position **P3** along the movable direction with a simple configuration.

[0158] In the push-button switch **1** according to the fifth aspect of the present disclosure,

[0159] the first biasing portion is configured by a plurality of coil springs.

[0160] According to the push-button switch **1** of the fifth aspect, the plunger **40** can be biased from the return position **P3** toward the operating position **P4** along the movable direction with a simple configuration.

[0161] In the push-button switch **1** according to the sixth aspect of the present disclosure,

[0162] the lever support portion **34** surrounds the end **22** of the operation unit **20** on the housing portion **11** side around the movable direction, has an inner circumferential surface **341** disposed so as to face the end **22** of the operation unit **20** on the housing portion **11** side, and has a locking projection **342** protruding from the inner circumferential surface **341** toward the operation unit **20**,

[0163] the end **22** of the operation unit **20** on the housing portion **11** side has

[0164] a first groove **23** extending in the movable direction and capable of housing the locking projection **342** when the lever body **31** is at the first position **P1**, and

[0165] a second groove **24** which is connected to the end of the first groove **23** on the pressing surface **21** side in the movable direction and extends along the circumferential direction of the end **22** of the operation unit **20** on the housing portion **11** side so as to be capable of housing the locking projection **342** and which locks the locking projection **342** in the movable direction when the lever body **31** is at the second position **P2**, and

[0166] the movement regulating portion **80** includes the locking projection **342**, the first groove **23**, and the second groove **24**.

[0167] According to the push-button switch **1** of the sixth aspect, the movement of the lever body **31** to the second position can be regulated with a simple configuration, so that the push-button switch **1** capable of reliably attaching the operation unit **20** in a complete state can be easily realized.

[0168] In addition, by appropriately combining any of the above-described various embodiments or modifications, the effects of the respective embodiments or modifications can be achieved. In addition, a combination of the embodiments or a combination of the examples or a combination of the embodiment and the example is possible, and a combination of the features in the different embodiments or the examples is also possible.

[0169] Although the present disclosure has been fully described in connection with preferred embodiments with reference to the accompanying drawings, various variations and modifications will be apparent to those skilled in the art. It is to be understood that such variations and modifications are included therein unless they depart from the scope of the present disclosure as set forth in the appended claims.

INDUSTRIAL APPLICABILITY

[0170] The push-button switch of the present disclosure can be applied to, for example, an emergency stop switch.

REFERENCE SIGNS LIST

- [0171] 1. push-button switch
- [0172] 10. housing
- [0173] 11. housing portion
- [0174] 12. operation surface
- [0175] 13. operation hole
- [0176] 14. terminal connection surface
- [0177] 141. opening
- [0178] 15. fulcrum forming surface
- [0179] 151. fulcrum projection
- [0180] 152. curved surface
- [0181] 16. terminal connection mechanism
- [0182] 161. first terminal connection mechanism
- [0183] 162. second terminal connection mechanism
- [0184] 17. deformation portion
- [0185] 18. wall
- [0186] 20. operation unit
- [0187] 21. pressing surface
- [0188] 22. end
- [0189] 23. first groove
- [0190] 231. end
- [0191] 24. second groove
- [0192] 25, 26. display portion
- [0193] 30. lock lever unit

[0194] 301. lever portion
 [0195] 31. lever body
 [0196] 311. facing surface
 [0197] 312. locking portion
 [0198] 313. hold releasing portion
 [0199] 314. protection wall
 [0200] 32. exterior portion
 [0201] 321. first wall portion
 [0202] 322. second wall portion
 [0203] 323. third wall portion
 [0204] 33. holding unit
 [0205] 331. elastic holding portion
 [0206] 332, 333. end
 [0207] 34. lever support portion
 [0208] 341. inner circumferential surface
 [0209] 342. locking projection
 [0210] 343. cam projection
 [0211] 344. through hole
 [0212] 345. lever connection portion
 [0213] 346. inclined portion
 [0214] 35. leg
 [0215] 351. outer circumferential surface
 [0216] 36, 37. display portion
 [0217] 40. plunger
 [0218] 41. first plunger
 [0219] 411. through hole
 [0220] 412. cam groove
 [0221] 413. recess
 [0222] 414. inner circumferential surface
 [0223] 42. second plunger
 [0224] 421. main body
 [0225] 422. plunger connection portion
 [0226] 423. through hole
 [0227] 424. annular wall
 [0228] 50. transmission mechanism
 [0229] 60. contact mechanism
 [0230] 61. fixed contact portion
 [0231] 62. movable contact portion
 [0232] 63. NO contact
 [0233] 64. NC contact
 [0234] 70. biasing portion
 [0235] 71, 72. coil spring
 [0236] 80. movement regulating portion
 [0237] 90. LED unit
 [0238] 100. jig
 [0239] 101. distal end
 [0240] 102. intermediate portion
 [0241] P1. first position
 [0242] P2. second position
 [0243] P3, P31, P32. return position
 [0244] P4, P41, P42. operating position
 [0245] A, B. arrow
 [0246] CP. center
 [0247] CL. center line

1. A push-button switch comprising:
 a housing having an operation surface provided with an operation hole and a housing portion provided therein and connected to the operation hole;
 a plunger provided at an inside of the housing portion and movable between a return position away from the operation surface and an operating position in the middle between the operation surface and the return position along a movable direction intersecting the operation surface;

an operation unit that extends along the movable direction from an outside of the housing through the operation hole to the inside of the housing portion and is mounted to the housing in a state in which an end on the housing portion side in an extending direction is positioned at an initial position, and has a pressing surface provided at the outside of the housing and disposed so as to face the operation surface, in which the pressing surface is capable of an approaching operation with respect to the operation surface along the movable direction, and the end on the housing portion side moves from the initial position to a pressing position to position the plunger at the return position by the approaching operation;

a lock lever unit that has a lever body exposed to the outside of the housing and movable in a direction intersecting the movable direction between a first position and a second position, a lever support portion provided at the inside of the housing portion and connected to the lever body so as to be movable together with the lever body, and a holding unit capable of holding the lever body at the second position;

a transmission mechanism that is provided between the lock lever unit and the plunger inside the housing portion, moves the plunger from the return position to the operating position along the movable direction as the lever body moves from the first position toward the second position, and moves the plunger from the operating position to the return position along the movable direction as the lever body moves from the second position toward the first position;

a movement regulating portion that is provided between the operation unit and the lock lever unit inside the housing portion, and when the lever body is positioned at the first position, enables movement of the lever body to the second position when the end of the operation unit on the housing portion side is positioned at the initial position, and disables movement of the lever body to the second position when the end of the operation unit on the housing portion side is positioned closer to the operation surface than the initial position in the movable direction;

a contact mechanism that has a fixed contact portion provided at the inside of the housing portion and a movable contact portion that is provided at the inside of the housing portion so as to face the fixed contact portion, comes into contact with the fixed contact portion when the plunger moves from the return position to the operating position, and separates from the fixed contact portion when the plunger moves from the operating position to the return position; and

a first biasing portion provided inside the housing portion and biasing the plunger from the operating position toward the return position along the movable direction.

2. The push-button switch according to claim 1 further comprising

a second biasing portion provided inside the housing portion and biasing the plunger from the return position toward the operating position along the movable direction, wherein

the biasing force of the first biasing portion is configured to be larger than the biasing force of the second biasing portion,

the plunger has

- a first plunger disposed capable of being biased by the first biasing portion and movable along the movable direction between the return position and the operating position by the transmission mechanism as the lever body moves between the first position and the second position, and
- a second plunger that is disposed farther away from the operation surface along the movable direction than the first plunger in a state capable of being biased by the second biasing portion and disposed in series with the first plunger along the movable direction, and is positioned at the return position by the approaching operation of the operation unit,

the first plunger and the second plunger are movable along the movable direction independently of each other, and

the movable contact portion is configured to contact with or separate from the fixed contact portion by movement of the second plunger along the movable direction.

3. The push-button switch according to claim 2, wherein the first plunger has

- a plurality of cam grooves which are provided on the inner circumferential surface of the through hole that penetrates in the movable direction and disposed at an interval from each other in the circumferential direction of the inner circumferential surface and which are respectively inclined so as to separate from the operation surface along the moving direction from the first position of the lever body toward the second position,

the lever support portion

- is disposed in the through hole and extends along the inner circumferential surface of the through hole, and
- has a plurality of cam projections which are provided so as to respectively correspond to the plurality of cam grooves and protrude from the outer circumferential surface facing the inner circumferential surface of the

- lever support portion toward the inner circumferential surface and which respectively engage with the corresponding plurality of cam grooves, and

the transmission mechanism includes the plurality of cam grooves, the lever support portion, and the plurality of cam projections.

4. The push-button switch according to claim 2, wherein the second biasing portion is configured by at least one coil spring.

5. The push-button switch according to claim 1, wherein the first biasing portion is configured by a plurality of coil springs.

6. The push-button switch according to claim 1, wherein the lever support portion surrounds the end of the operation unit on the housing portion side around the movable direction, has an inner circumferential surface disposed so as to face the end of the operation unit on the housing portion side, and has a locking projection protruding from the inner circumferential surface toward the operation unit,

the end of the operation unit on the housing portion side has

- a first groove extending in the movable direction and capable of housing the locking projection when the lever body is at the first position, and
- a second groove which is connected to the end of the first groove on the pressing surface side in the movable direction and extends along the circumferential direction of the end of the operation unit on the housing portion side so as to be capable of housing the locking projection and which locks the locking projection in the movable direction when the lever body is at the second position, and

the movement regulating portion includes the locking projection, the first groove, and the second groove.

* * * * *