



(12) **EUROPEAN PATENT APPLICATION**

(43) Date of publication:  
**25.08.2004 Bulletin 2004/35**

(51) Int Cl.7: **A63H 30/04**, A63H 33/04,  
A63H 31/00, A63H 31/08,  
A63H 29/00, A63H 17/395,  
A63H 17/36, A63H 17/26

(21) Application number: **04250654.3**

(22) Date of filing: **06.02.2004**

(84) Designated Contracting States:  
**AT BE BG CH CY CZ DE DK EE ES FI FR GB GR  
HU IE IT LI LU MC NL PT RO SE SI SK TR**  
Designated Extension States:  
**AL LT LV MK**

(71) Applicant: **Tomy Company, Ltd.**  
**Tokyo 124-8511 (JP)**

(72) Inventor: **Yoneda, Yousuke**  
**Katsushika-ku Tokyo, 124-8511 (JP)**

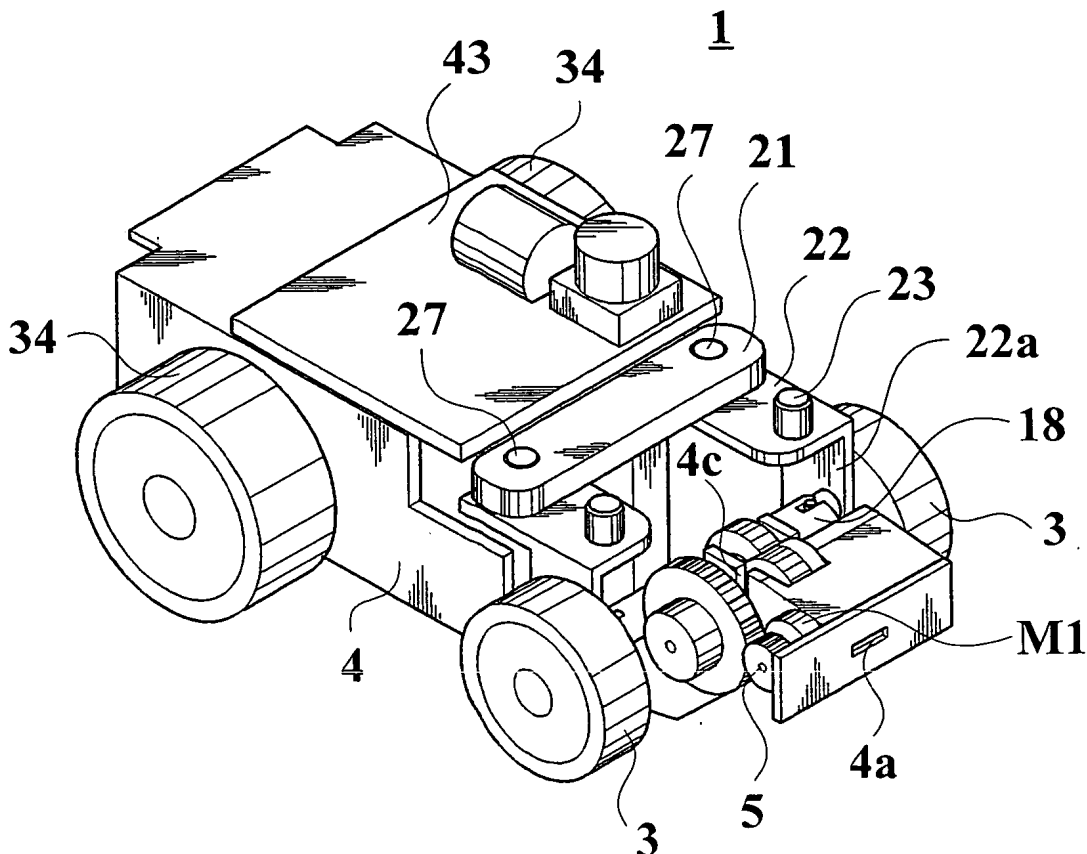
(30) Priority: **14.02.2003 JP 2003037182**  
**29.09.2003 JP 2003338576**

(74) Representative: **Brookes Batchellor**  
**102-108 Clerkenwell Road**  
**London EC1M 5SA (GB)**

(54) **Toy vehicle**

(57) A toy vehicle (1) which performs running control and steering control according to a signal from a radio controller, having a motor (M1) mounted on a front part of a chassis (4), for driving a front wheel (3).

**FIG. 2**



**Description**

## BACKGROUND OF THE INVENTION

## Field of the Invention

**[0001]** The present invention relates a toy vehicle which performs running control and steering control according to a signal from a radio controller.

## Description of the Related Art

**[0002]** Earlier, a toy vehicle which performs running control and steering control according to a signal from a radio controller has been well known. The toy vehicle drives rear wheels to run, and changes a direction of front wheels to perform steering by receiving a signal from the radio controller (see, for example, Japanese Patent Application Publication (Unexamined) No. Tokukai-2002-166064).

**[0003]** A rear-wheel-drive vehicle raises a problem in operability. Specially, when running the toy vehicle on a floor face, the rear wheels of the toy vehicle slips on the floor face, thereby making a control difficult.

## SUMMARY OF THE INVENTION

**[0004]** The present invention has been developed in view of solving the problem, and an object of the present invention is to provide a toy vehicle with excellent operability.

**[0005]** In accordance with a first aspect of the invention, the toy vehicle which performs running control and steering control according to a signal from a radio controller, comprises:

a motor mounted on a front part of a chassis, for driving a front wheel.

**[0006]** According to the toy vehicle, since the motor is mounted near the front wheel for performing steering, it can provide an excellent road holding by the weight of the motor. Moreover, since the toy vehicle is the front-wheel-drive vehicle, the operability is improved.

**[0007]** Preferably, the motor is mounted adjacent to a front wheel axle.

**[0008]** A position for mounting the motor may be on the front side of the front wheel axle or just behind the front wheel axle.

**[0009]** A steering method is not particularly limited, however, the steering can be performed by a four-section rotational linkage. A driving method for the four-section rotational linkage is not limited, however, the four-section rotational linkage can be driven by utilizing a repulsive force or an attraction force acting between a permanent magnet (or a non-magnetized magnetic material) and a coil.

**[0010]** According to the toy vehicle, since the motor is

mounted near the front wheel axle, a power transmission mechanism becomes simple, thereby making the toy vehicle compact.

**[0011]** Preferably, the motor is detachably mounted on the chassis.

**[0012]** In this case, it is preferable to prepare motors with different properties in revolution speed, torque or the like.

**[0013]** According to the toy vehicle, the motor can be replaced to that with the number of revolutions according to the course.

**[0014]** Preferably, the toy vehicle further comprises an intermediate shaft which comprises a first gear and a second gear which are engaged with a third gear fixed on a motor shaft of the motor and a fourth gear fixed on the front wheel axle, respectively, and is detachably mounted on the chassis between the motor shaft and the front wheel axle.

**[0015]** According to the toy vehicle, since the intermediate shaft can be replaced to that with gears having different number of teeth, the number of revolutions of the wheel corresponding to the course can be obtained.

**[0016]** Preferably, one ends of right and left driven links are supported by the chassis swingably in a horizontal direction, a driving link is crossed over between other ends of the right and left driven links, two spindles are swingably supported by the right and left driven links, and each of the two spindles is connected to the front wheel axle.

**[0017]** Preferably, one ends of right and left driven links are supported by the chassis swingably in a horizontal direction, a driving link is crossed over between other ends of the right and left driven links, two spindles are swingably supported by the right and left driven links, each of the two spindles is connected to the front wheel axle through a flexible joint, the front wheel axle is supported by the two spindles without being supported by the chassis, and the flexible joint comprises a spherical shaped part provided on one of the spindle and the front wheel axle, and a cylindrical body provided on the other thereof, the spherical shaped part comprising protrusions at positions opposite to each other across a center of an axis of the spherical shaped part, slits being formed in the cylindrical body at positions opposite to each other across a center of an axis of the cylindrical body, the spherical shaped part being engaged with the cylindrical body with the protrusions fitting in the slits.

**[0018]** According to the toy vehicle, since the front wheel axle is supported by the two spindles without being supported by the chassis, the steering can be performed smoothly even when an axis shift of the front wheel axle and each spindle occurs.

**[0019]** Preferably, one ends of right and left driven links are supported by the chassis swingably in a horizontal direction, a driving link is crossed over between other ends of the right and left driven links, two spindles are swingably supported by the right and left driven

links, each of the two spindles is connected to the front wheel axle through a flexible joint, the front wheel axle is supported by the chassis, the front wheel axle is supported by the two spindles, and the flexible joint comprises a cylindrical body provided on one of the spindle and the front wheel axle, and an engaging part provided on the other thereof to protrude radially, end parts of the two spindles and the front wheel axle fitting with each other, a slit for making the engaging part fit therein being formed in the cylindrical body, and the engaging part fitting in the slit.

**[0020]** According to the toy vehicle, since the ends of the spindles and the front wheel axle are made to fit each other, the steering can be performed smoothly.

**[0021]** Preferably, the driving link comprises a permanent magnet, and coils provided at positions across the permanent magnet.

**[0022]** The driving link may comprise a coil, and permanent magnets provided at positions across the coil.

**[0023]** The driving link may comprise a non-magnetized magnetic material, and coils provided at positions across the non-magnetized magnetic material.

**[0024]** Preferably, a rear wheel is provided with a suspension structure.

**[0025]** According to the toy vehicle, since the road holding of the rear wheel is improved, the toy vehicle can run stably.

#### BRIEF DESCRIPTION OF THE DRAWINGS

**[0026]** The present invention will become more fully understood from the detailed description given hereinafter and the accompanying drawings which are given by way of illustration only, and thus are not intended as a definition of the limits of the present invention, and wherein;

FIG. 1 is a perspective view showing a toy vehicle in the first embodiment;

FIG. 2 is a schematic perspective view showing a state where a body is removed from the vehicle toy in FIG. 1;

FIGS. 3A and 3B are a perspective view explaining an attaching structure for a cover body covering a lower side of a motor of the vehicle toy in FIG. 1;

FIG. 4 is a schematic plan view showing a power transmission mechanism, a steering mechanism, and a suspension structure of the toy vehicle in FIG. 1;

FIG. 5 is a perspective view showing a flexible joint of the toy vehicle in FIG. 1;

FIG. 6 is a perspective view showing a link driving mechanism of the toy vehicle in FIG. 1;

FIG. 7 is a view showing a part of a coil driving circuit of the toy vehicle in FIG. 1;

FIG. 8 is a view showing a circuitry of the toy vehicle in FIG. 1;

FIG. 9 is a plan view showing a power transmission

mechanism, a steering mechanism, and a suspension structure of a toy vehicle of the second embodiment;

FIG. 10 is a plan view showing a power transmission mechanism, a steering mechanism, and a suspension structure of a toy vehicle of the third embodiment;

FIG. 11 is a plan view showing a power transmission mechanism and a steering mechanism of a toy vehicle of the fourth embodiment;

FIG. 12 is a schematic cross sectional view showing a state of attaching the power transmission mechanism and the steering mechanism in FIG. 11 to a chassis;

FIG. 13 is a perspective view showing a power transmission mechanism and a steering mechanism of a toy vehicle of the fifth embodiment;

FIG. 14 is a schematic view showing a flexible joint in FIG. 13; and

FIG. 15 is a schematic cross sectional view showing a state of attaching the power transmission mechanism and the steering mechanism in FIG. 13 to a chassis.

#### DETAILED DESCRIPTION OF THE PREFERRED EMBODIMENTS

**[0027]** Hereinafter, the preferred embodiments of the present invention will be described in detail by reference to the attached drawings.

[ First Embodiment ]

**[0028]** FIG. 1 is a perspective view showing an exterior of a toy vehicle 1, and FIG. 2 is a schematic perspective view showing a state where a body 2 is removed.

**[0029]** The toy vehicle 1 is configured to move back and forth, and turn to the right or left according to control signals from a radio controller which is not shown. The configuration of the toy vehicle 1 will be explained in detail below.

(Attaching Structure of Motor)

**[0030]** A motor M1 for driving front wheels 3 is disposed at a front portion of a chassis 4, and a motor shaft 5 attached to the chassis 4 extends in a width direction of the toy vehicle 1.

**[0031]** The motor M1 is attachable/detachable from the lower side of the chassis 4, and is covered at the lower side by a cover body 6 in a state of being attached to the chassis 4 (refer to FIGS. 3A and 3B).

(Structure of Cover Body)

**[0032]** The cover body 6 attachable/detachable to the chassis 4 comprises a bottom plate part 6a for covering

the lower side of the motor M1 and a standing part 6b which stands from the bottom plate part 6a as shown in FIG. 3A. The standing part 6b is provided with a protrusion 7 on the inside thereof. Slits 9 are formed at both sides of the bottom plate part 6a, and a claw 8 which projects to a lateral direction is formed at each tip of the outer portions formed by the slits 9. The claws 8 are adapted to be elastically deformable to the inside of the cover body 6.

**[0033]** A hole 4b is formed in the end surface of the bottom plate portion of the chassis 4, and dents 4d are formed on the inner surface of the hole 4b.

**[0034]** A tip of the bottom plate part 6a is inserted in the hole 4b of the chassis 4 to engage the claws 8 at both sides of the bottom plate part 6a with the dents 4d, and the protrusion 7 inside of the standing part 6b is engaged with a hole 4a in a front plate portion of the chassis 4, thereby attaching the cover body 6 to the chassis 4.

(Power Transmission Mechanism)

**[0035]** As shown in FIG. 4, a gear 10 is fixed on a motor shaft 5. The intermediate shaft 11 is disposed to be in parallel with the motor shaft 5, and is attachably/detachably engaged to the slit 4c (refer to FIG. 2) from upper side. A large diameter gear 12 engaged with the gear 10 and a small diameter gear 13 are fixed on the intermediate shaft 11.

**[0036]** The front wheel axle 14 is disposed to be in parallel with the intermediate shaft 11, and a large diameter gear 15 engaged with the gear 13 is fixed on the front wheel axle 14. The front wheels 3 are connected at the both sides of the front wheel axle 14 through flexible joints 16, respectively.

**[0037]** As shown in FIG. 5, each flexible joint 16 comprises a cylindrical body 18 fixed on the front wheel axle 14, and a spindle 19 which is fixed to the front wheel 3 at an outer end and has a spherical shaped part 19a at the inner end which is inserted to the cylindrical body 18. In the cylindrical body 18, slits 18a are formed at positions opposite to each other across the center of an axis of the cylindrical body 18. The spherical shaped part 19a of the spindle 19 is provided with protrusions 19b which fit into the slits 18a.

**[0038]** According to the power transmission mechanism of this configuration, the power from the motor is transmitted to the front wheels 13 through the gears 10 and 12, the intermediate shaft 11, the gears 13 and 15, the front wheel axle 14, the flexible joints 16 and the spindles 19.

(Steering Mechanism)

**[0039]** As shown in FIG. 4, the toy vehicle 1 comprises a driving link 21 and a driven links 22 which forms a turning pair with the driving link 21. These links form a four-section rotational linkage in which the chassis portion

between the shafts 23, 23 of the right and left driven links 22 acts as a fixed link. When the driven links 22 sway centering around the shafts 23 by the movement of the driving link 21, the direction of the front wheels 3 supported by vertical plates 22a (refer to FIG. 2) is adapted to change in linking with the driven links 22.

**[0040]** As shown in FIG. 6, a holder 26 is disposed on the lower side of the central portion of the driving link 21, on which a permanent magnet 24 is provided. The permanent magnet 24 is formed in a disk shape, and both end surfaces thereof face in the right and left directions, respectively. One end surface of the permanent magnet 24 is a south pole, and the other one thereof is a north pole. The chassis 4 is provided with coils 25, 25 at positions across the permanent magnet 24. One end parts of coils 25, 25 face the end surfaces of the permanent magnet 24 provided on the driving link 21.

**[0041]** Each shaft 23 is positioned such that the shaft line of each shaft 23 passes through the connecting part of the front wheel 14 and the spindle 19, that is, the spherical shaped part 19a. In other words, three shaft lines of the shaft 23, the front wheel 14 and the spindle 19 intersect each other.

**[0042]** FIG. 7 shows a portion of the coil driving circuit. Energization of the coil driving circuit is controlled by a control device. The coil driving circuit is configured to energize both of the right and left coils 25 at the same time. When both of the coils 25 are energized at the same time, the polarities of the coils 25 on the sides which face the end surfaces of the permanent magnet 24 become homopolar (north pole or south pole). Accordingly, when the right and left coils 25 are energized, attractive force is generated between one coil 25 and the permanent magnet 24, and repulsive force is generated between the other coil 25 and the permanent magnet 24. Therefore, the driving link 21 and thus the driven links 22, 22 sway centering around the shaft 23, thereby changing the direction of the front wheels 3.

(Suspension Structure of Rear Wheel)

**[0043]** A rear wheel axle 35 of right and left rear wheels 34 shown in FIG. 4 is covered by an axle cover 30. The axle cover 30 is provided with a shaft 31 which extends in the back and forth directions of the toy vehicle 1, and the shaft 31 is supported by the chassis 4. Thus, the right and left rear wheels 34 perform seesaw movement centering on the shaft 31. The axle cover 30 is provided with projected pieces 32, 32, each of which is provided with a coil spring 33 at a tip thereof. The coil springs 33, 33 are adapted to contact with the bottom plate portion of the chassis 4 from the lower side, thereby absorbing the up and down movement of the toy vehicle 1.

(Circuit Structure)

**[0044]** As shown in FIG. 8, the control signals from

the radio controller are received by an antenna (not shown) to perform demodulation or the like by a processing section 40. A control device 42 controls a coil driving circuit 44 and a motor driving circuit 45, and thus the motor M1 and the coils 25 according to operation program stored in a storing section 41. These circuit elements are mounted on a circuit board 43 (refer to FIG. 2).

(Other Structure)

**[0045]** The circuit board 43 is provided with a battery storage space (not shown) at the lower side thereof, in which a battery can be mounted.

(Operation and Effect of Toy Vehicle in the Embodiment)

**[0046]** Since the motor M1 is disposed near the front wheels 3 for performing steering, the road holding of the front wheels 3 is improved by the weight of the motor M1. Moreover, since the toy vehicle 1 is the front-wheel-drive vehicle, the operability is improved.

**[0047]** Since the motor M1 can be replaced according to the course, it can realize broad options for playing, thereby increasing interest in playing.

**[0048]** The suspension structure is provided on the rear wheels 34 side, so that the road holding of the rear wheels 34 is improved, thereby realizing stable running.

[Second Embodiment]

**[0049]** FIG. 9 shows a power transmission mechanism, a steering mechanism and a suspension structure of a toy vehicle in the second embodiment. In this embodiment, the power transmission mechanism and the suspension structure of the toy vehicle are different from those in the first embodiment. Other structures are similar to those of the toy vehicle 1 in the first embodiment, thus the explanation thereof is omitted here.

(Power Transmission Mechanism)

**[0050]** In the power transmission mechanism in this embodiment, the gears 12 and 13 of the toy vehicle 1 in the first embodiment are united.

(Suspension Structure)

**[0051]** A shaft 51 is rotatably supported by the chassis 4. Cylinder shafts 53, 53 are rotatably engaged with end portions of both sides of the shaft 51, respectively. One ends of swaying arms 52, 52 which extend toward backward are supported at outer end sides of the cylinder shafts 53, 53, respectively. The other ends of the swaying arms 52, 52 support rear wheel axles 50, 50, respectively. The right and left rear wheels 34, 34 are rotatably supported by the rear wheel axles 50, 50, respectively. A projected piece 54 which extends toward

backward is provided at each inner end side of the cylinder shafts 53, 53. A spring 55 is provided at each tip part of the projected pieces 54, 54. The springs 55, 55 are adapted to contact with the bottom plate portion of the chassis 4 from the lower side.

**[0052]** As described above, the toy vehicle is configured such that the swaying arms 52 on right and left sides are individually movable up and down, thereby absorbing the up and down movement of each wheel 34, 34 individually.

[Third Embodiment]

**[0053]** FIG. 10 shows a power transmission mechanism, steering mechanism and suspension structure of a toy vehicle in the third embodiment. In this embodiment, the power transmission mechanism of the toy vehicle is different from that in the first embodiment. Other structures are similar to those of the toy vehicle 1 in the first embodiment, thus the explanation thereof is omitted here.

(Power Transmission Mechanism)

**[0054]** As shown in FIG. 10, a gear 60 is fixed on the motor shaft 5. The intermediate shaft 11 is disposed to be in parallel with the motor shaft 5, and a large diameter gear 61 is fixed on the intermediate shaft 11. The gears 60 and 61 are engaged with each other.

**[0055]** A small diameter gear 62 is also fixed on the intermediate shaft 11 integrally with the gear 61. The gear 62 is engaged with a gear 63b fixed on one spindle 64.

**[0056]** A gear 65 having the same diameter and the same number of teeth as those of the gear 62 is fixed on the intermediate shaft 11. The gear 65 is engaged with a gear 66 fixed on the other spindle 64.

**[0057]** According to the power transmission mechanism, the power from the motor is transmitted to one front wheel 3 through the gears 60, 61, 62, 63 and the spindle 64, and also transmitted to the other front wheel 3 through the gears 60, 61, the intermediate shaft 11, the gears 65, 66 and the spindle 64.

**[0058]** In the toy vehicle 1, the shafts 23, 23 of the right and left driven links 22, 22 are positioned such that the shaft lines of the shafts 23, 23 pass through engaged portions of the gears 62 and 63, and the gears 65 and 66, respectively. Even when the right and left driven links 22, 22 sway, the engagements of the gears 62 and 63, and the gears 65 and 66 are not released. This configuration does not need the flexible joint 16.

[Fourth Embodiment]

**[0059]** FIG. 11 shows a power transmission mechanism and a steering mechanism of a toy vehicle in the fourth embodiment. In this embodiment, the power transmission mechanism and the steering mechanism

of the toy vehicle are different from those in the first embodiment. Other structures are similar to those of the toy vehicle 1 in the first embodiment, thus the explanation thereof is omitted here.

(Power Transmission Mechanism)

**[0060]** In this power transmission mechanism, an intermediate shaft is omitted, and the large diameter gear 15 is positioned at the end part of the front wheel axle 14. Moreover, the gear 15 is engaged with the gear 10 of the motor shaft 5 which is not shown, and the cylindrical body 18 of one flexible joint 16 is disposed to be unified with the large diameter gear 15.

(Steering Mechanism)

**[0061]** In this steering mechanism, the holder 26 is disposed between the right and left driven links 22, and as shown in FIG. 12, the shafts 23 of the driven links 22 are supported by the chassis 4.

**[0062]** In this embodiment, since the intermediate shaft is omitted, the motor M1 can be disposed near the front wheel axle 14. Moreover, the large diameter gear 15 can be disposed on one side in the width direction of the toy vehicle, so that the motor M can be disposed in a space formed between the right and left driven links 22 to face the holder 26.

**[0063]** In this embodiment, the front wheel axle 14 is supported only by the spindles 19 on which the front wheels 3 are fixed. Thus, when the right and left driven links 22 sway, the spindles 19 easily follow the movement. Therefore, the steering can be performed smoothly even when axis shift occurs.

**[0064]** It is required that the engagement of the gears 15 and 10 are not released even when the front wheel axle 14 slightly moves by the movement of the spindles 19 which follows the movement of the right and left driven links 22.

[Fifth Embodiment]

**[0065]** FIG. 13 shows a power transmission mechanism and a steering mechanism of a toy vehicle in the fifth embodiment. In this embodiment, the power transmission mechanism of the toy vehicle is different from that in the fourth embodiment. Other structures are similar to those of the toy vehicle 1 in the fourth embodiment, thus the explanation thereof is omitted here.

(Power Transmission Mechanism)

**[0066]** In this power transmission mechanism, the flexible joint 16 is configured such that the end part of the spindle 19 is bent at a right angle, or a pin is fixed at a right angle on the shaft to form a protrusion 19c as shown in FIG. 14, and the protrusion 19c fits in the slit 18c of the cylindrical body 18 fixed on the end part of

the axle 14. The diameter of the spindle 19 is smaller than the inner diameter of the cylindrical body 18, and the axis of the spindle 19 is fit into the cylindrical body 18.

5 **[0067]** As shown in FIG. 15, this power transmission mechanism is configured such that the front wheel axle 14 and the shafts 23 of the driven links 22 are supported by the chassis 4.

**[0068]** In this embodiment, the flexible joint 16 can be simple in structure.

10 **[0069]** In the flexible joint 16, another protrusion 19c may be provided on the opposite side of the protrusion 19c on the spindle 19, and also another slit 18 may be formed in the cylindrical body 18 at position opposite to the slit 18 across an axis center to make the another protrusion 19c fit therein.

15 **[0070]** In this embodiment, each end part of the spindles 19 is fit into the cylindrical body 18 of the front wheel axle 14 while the front wheel axle 14 is supported by the chassis 4. Thus, when the right and left driven links 22 sway, the spindles 19 easily follow the movement thereof. Therefore, the steering can be performed smoothly.

[Modification of the Present Invention]

25 **[0071]** For example, in the embodiments above described, the permanent magnet 24 is provided on the driving link 21, and the coils 25 are provided at both sides thereof. However, on the contrary, the coil 25 may be provided on the driving link 21, and the permanent magnets 24 may be provided at both sides thereof. Also, a magnetic material which is not magnetized may be provided instead of the permanent magnet 24. That is, any structure may be employed if the driving link 21 is swayed by an electromagnetic force.

30 **[0072]** A return spring may be provided for making the driving link 21 keep a neutral position in right and left directions.

35 **[0073]** The entire disclosure of Japanese Patent Applications No. Tokugan 2003-037182 which was filed on February 14, 2003, and No. Tokugan 2003-338576 which was filed on September 29, 2003, including specification, claims, drawings and summary are incorporated herein by reference in its entirety.

## Claims

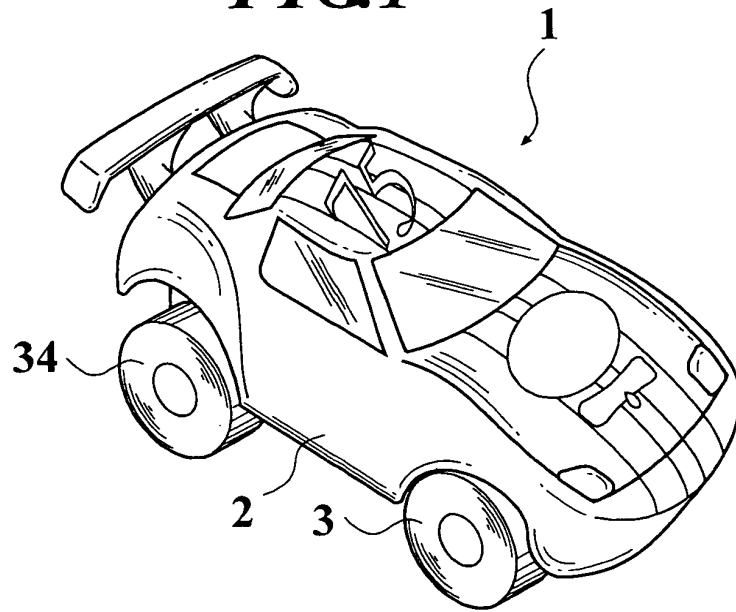
40 1. A toy vehicle which performs running control and steering control according to a signal from a radio controller, comprising:

a motor mounted on a front part of a chassis, for driving a front wheel.

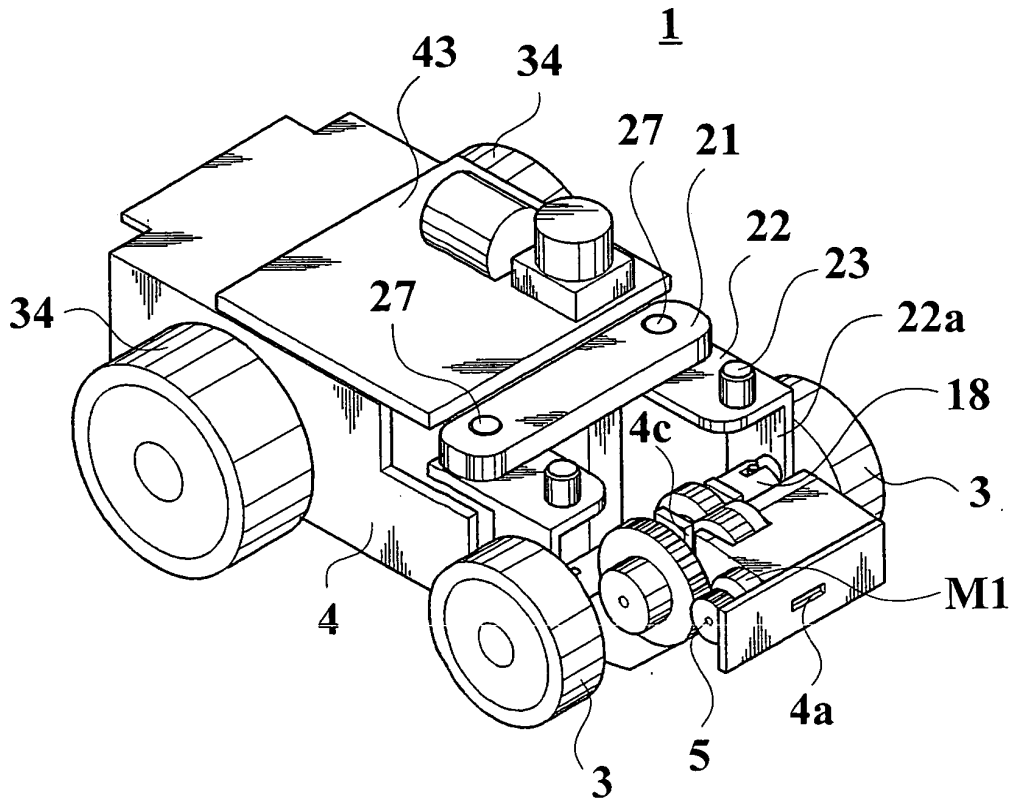
45 2. The toy vehicle as claimed in claim 1, wherein the motor is mounted adjacent to a front wheel axle.

3. The toy vehicle as claimed in claim 1 or 2, wherein the motor is detachably mounted on the chassis.
4. The toy vehicle as claimed in claim 3, further comprising an intermediate shaft which comprises a first gear and a second gear which are engaged with a third gear fixed on a motor shaft of the motor and a fourth gear fixed on the front wheel axle, respectively, and is detachably mounted on the chassis between the motor shaft and the front wheel axle.
5. The toy vehicle as claimed in any one of claims 1 to 4, wherein one ends of right and left driven links are supported by the chassis swingably in a horizontal direction, a driving link is crossed over between other ends of the right and left driven links, two spindles are swingably supported by the right and left driven links, and each of the two spindles is connected to the front wheel axle.
6. The toy vehicle as claimed in any one of claims 1 to 4, wherein one ends of right and left driven links are supported by the chassis swingably in a horizontal direction, a driving link is crossed over between other ends of the right and left driven links, two spindles are swingably supported by the right and left driven links, each of the two spindles is connected to the front wheel axle through a flexible joint, the front wheel axle is supported by the two spindles without being supported by the chassis, and the flexible joint comprises a spherical shaped part provided on one of the spindle and the front wheel axle, and a cylindrical body provided on the other thereof, the spherical shaped part comprising protrusions at positions opposite to each other across a center of an axis of the spherical shaped part, slits being formed in the cylindrical body at positions opposite to each other across a center of an axis of the cylindrical body, the spherical shaped part being engaged with the cylindrical body with the protrusions fitting in the slits.
7. The toy vehicle as claimed in any one of claims 1 to 4, wherein one ends of right and left driven links are supported by the chassis swingably in a horizontal direction, a driving link is crossed over between other ends of the right and left driven links, two spindles are swingably supported by the right and left driven links, each of the two spindles is connected to the front wheel axle through a flexible joint, the front wheel axle is supported by the chassis, the front wheel axle is supported by the two spindles, and the flexible joint comprises a cylindrical body provided on one of the spindle and the front wheel axle, and an engaging part provided on the other thereof to protrude radially, end parts of the two spindles and the front wheel axle fitting with each other, a slit for making the engaging part fit therein being formed in the cylindrical body, and the engaging part fitting in the slit.
8. The toy vehicle as claimed in any one of claims 5 to 7, wherein the driving link comprises a permanent magnet, and coils provided at positions across the permanent magnet.
9. The toy vehicle as claimed in any one of claims 5 to 7, wherein the driving link comprises a coil, and permanent magnets provided at positions across the coil.
10. The toy vehicle as claimed in any one of claims 5 to 7, wherein the driving link comprises a non-magnetized magnetic material, and coils provided at positions across the non-magnetized magnetic material.
11. The toy vehicle as claimed in any one of claims 1 to 10, wherein a rear wheel is provided with a suspension structure.

**FIG. 1**

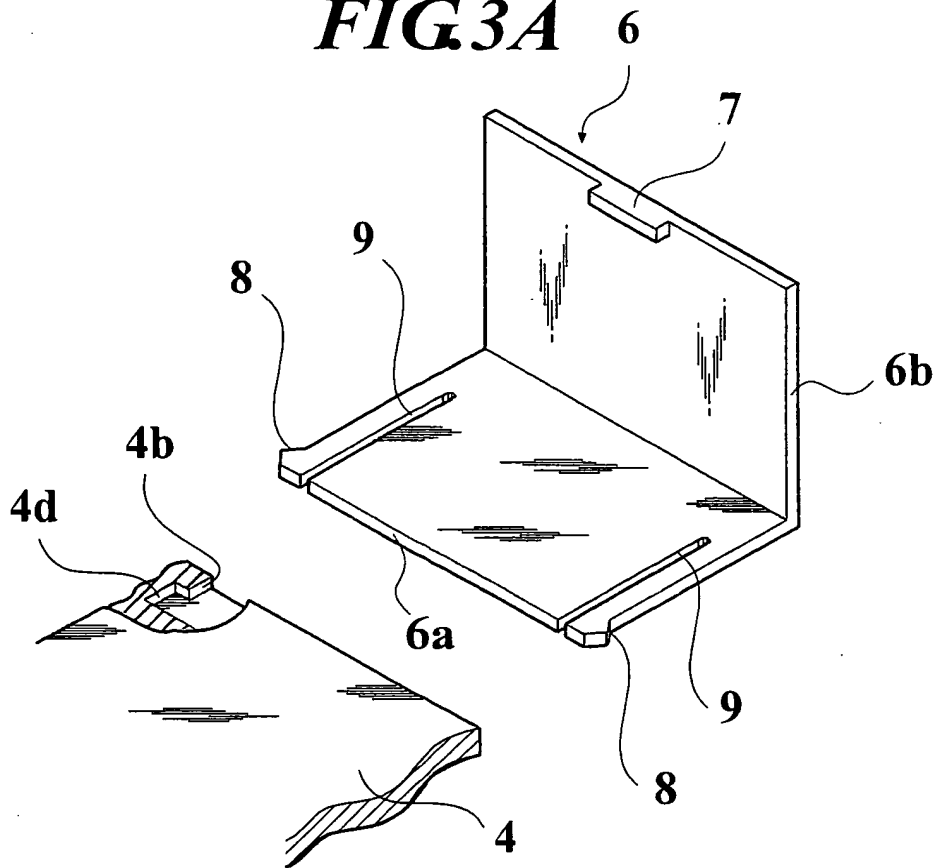


**FIG. 2**

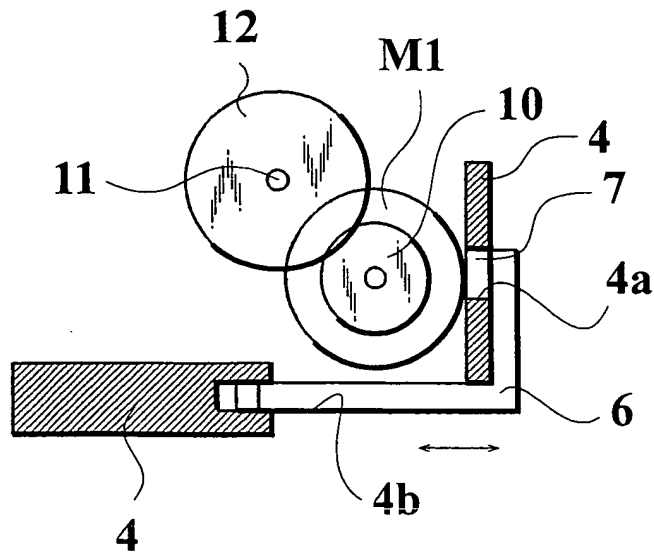




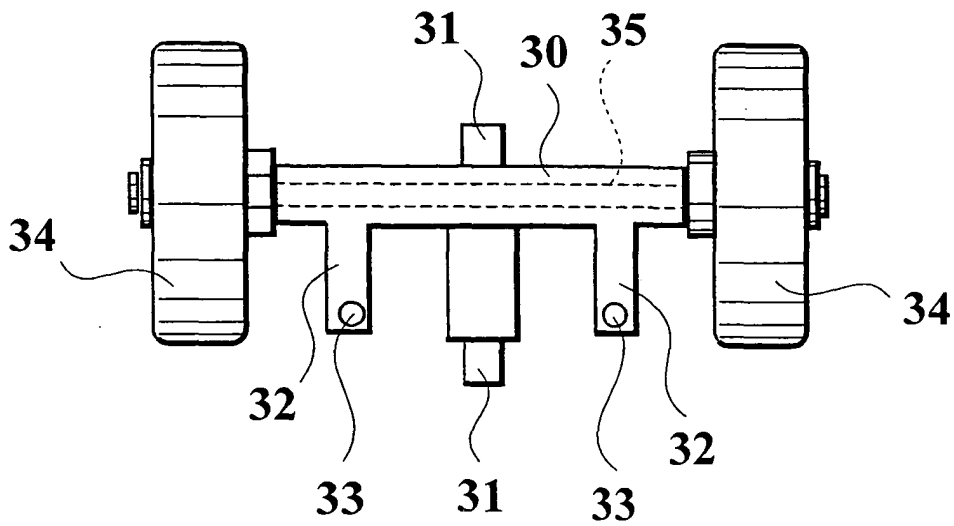
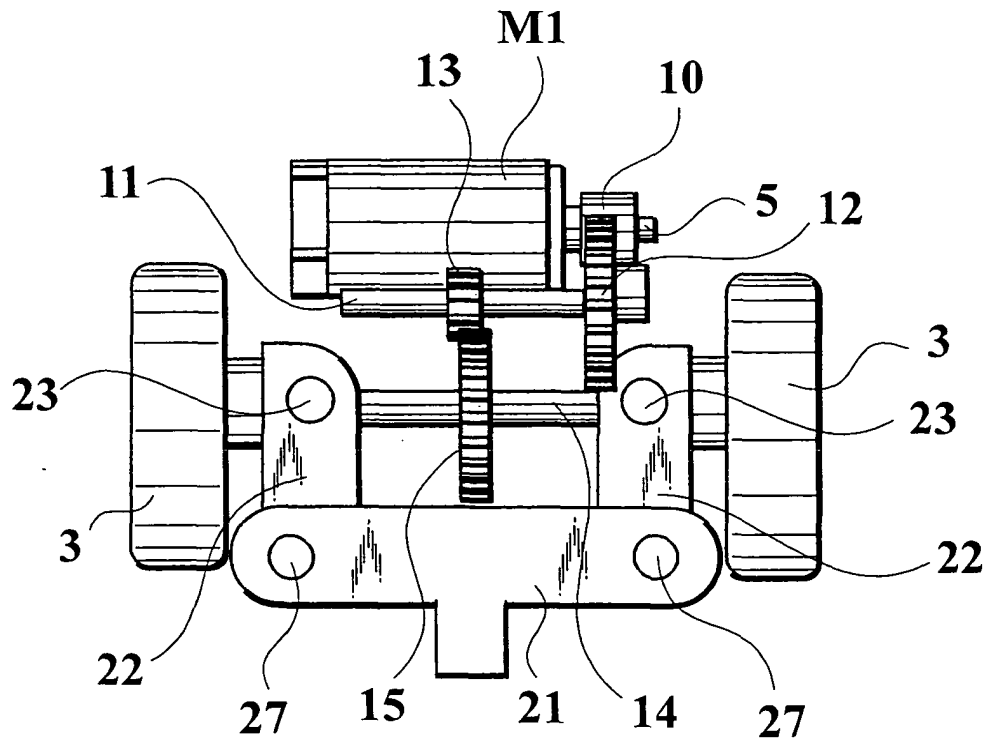
**FIG 3A**



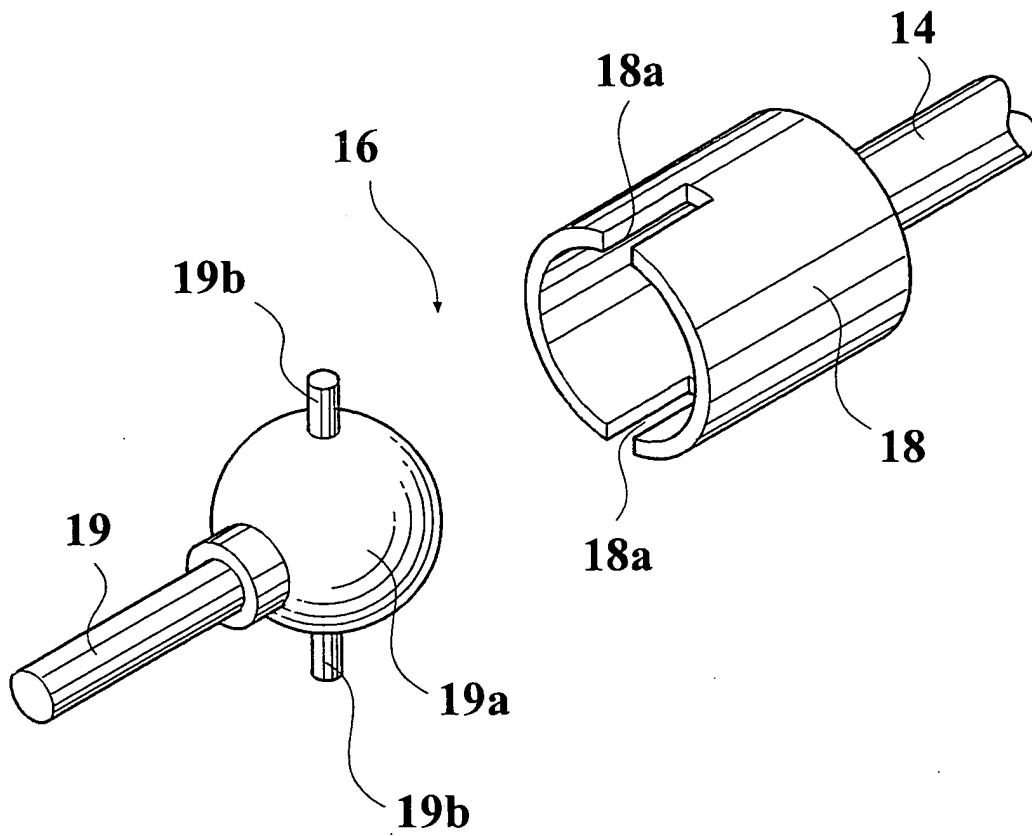
**FIG 3B**



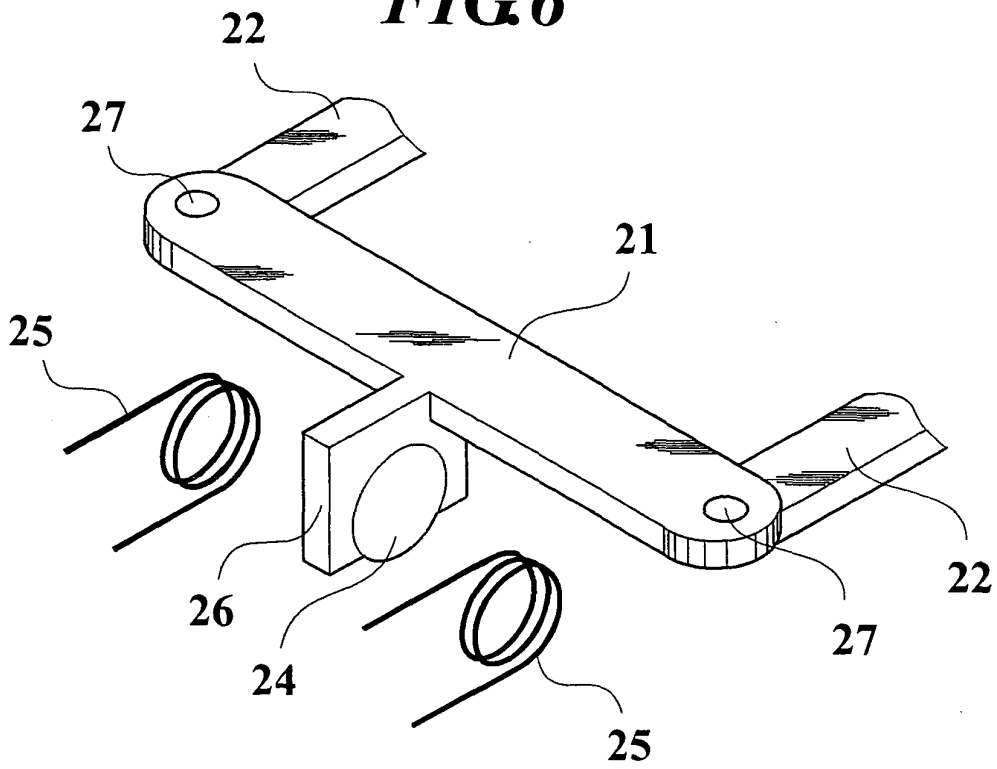
**FIG 4**



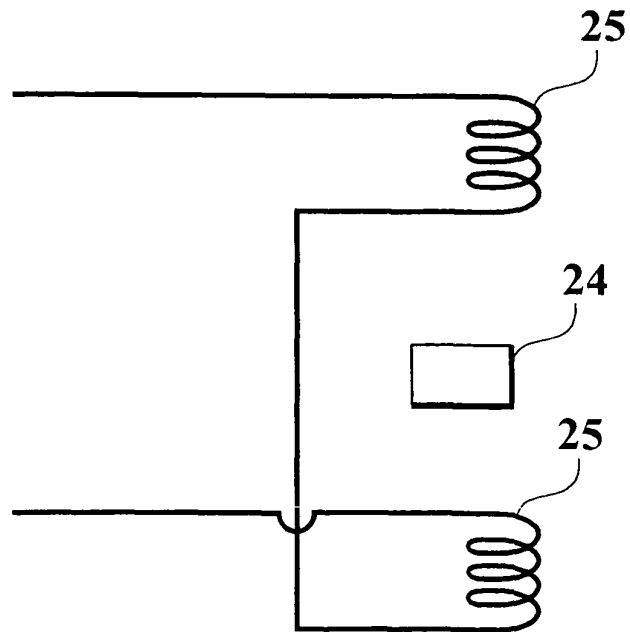
**FIG. 5**



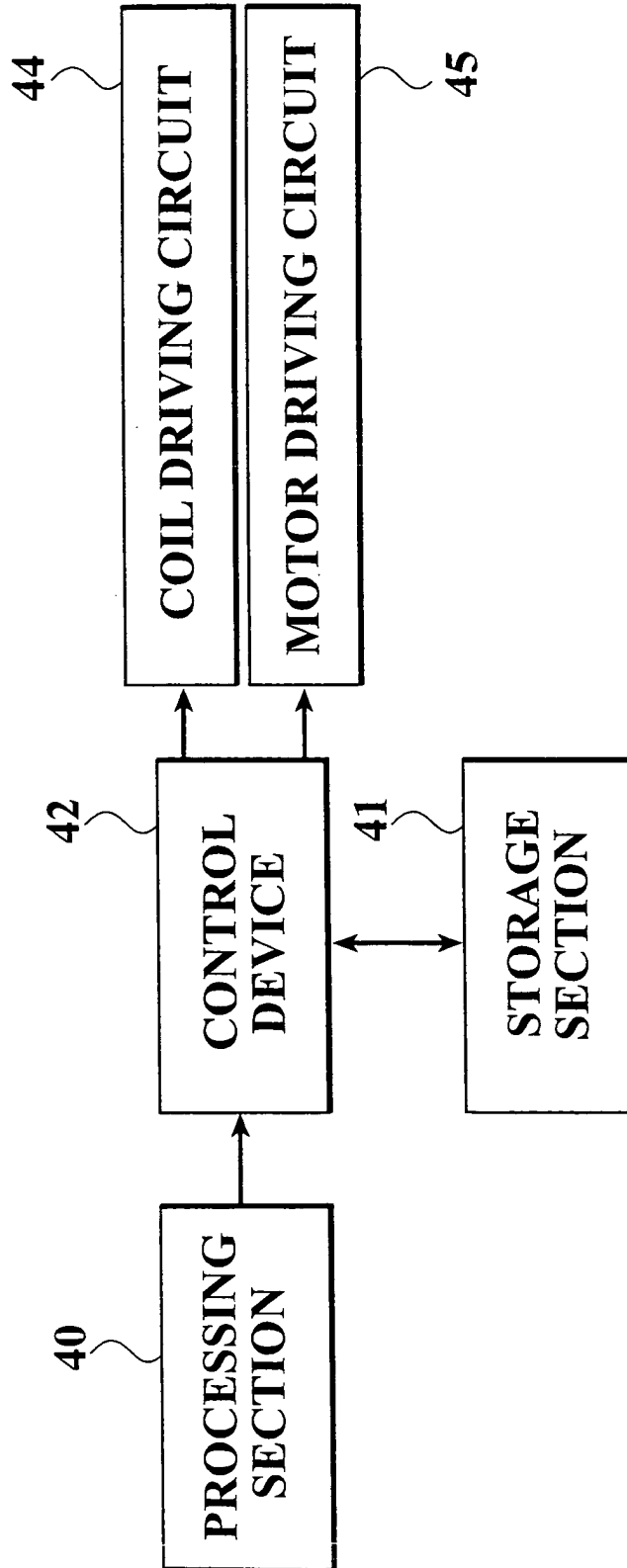
**FIG. 6**



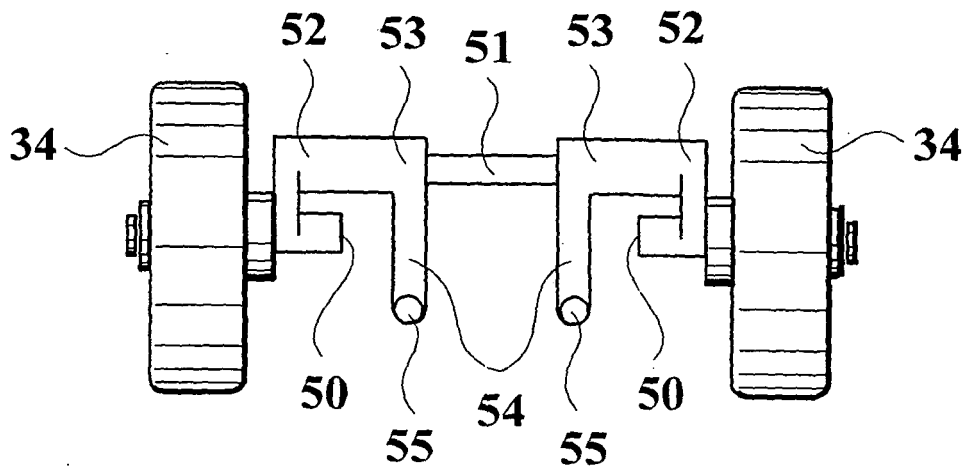
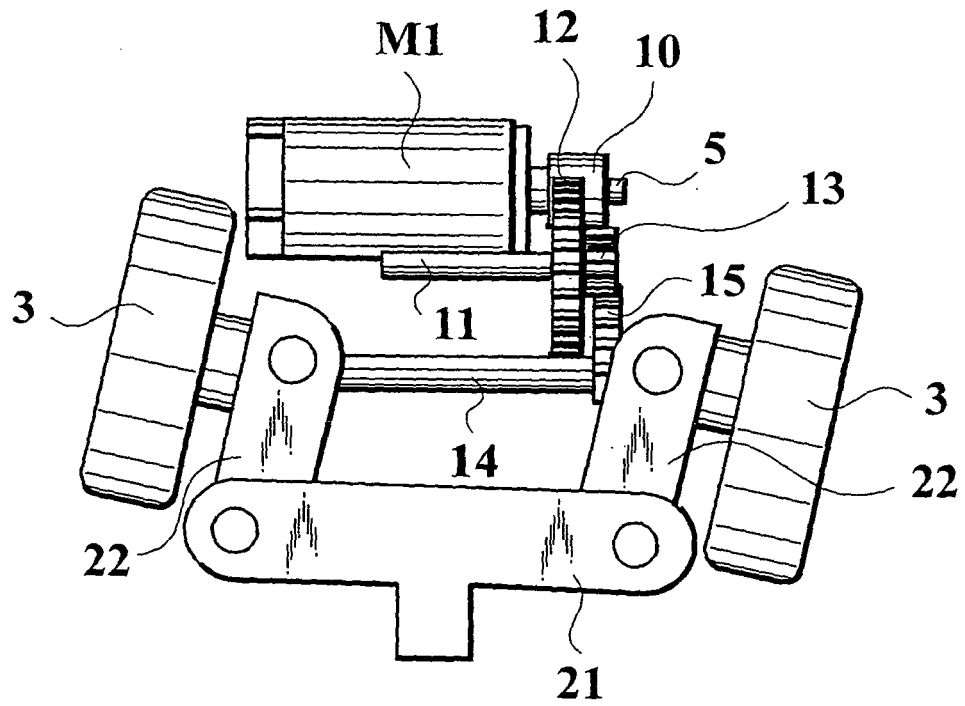
**FIG. 7**



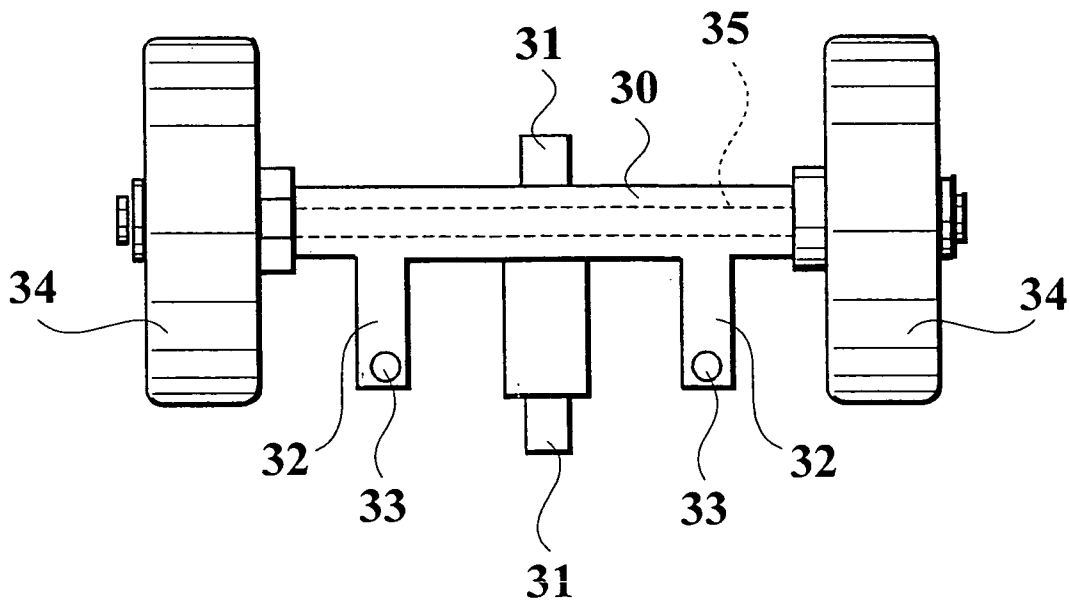
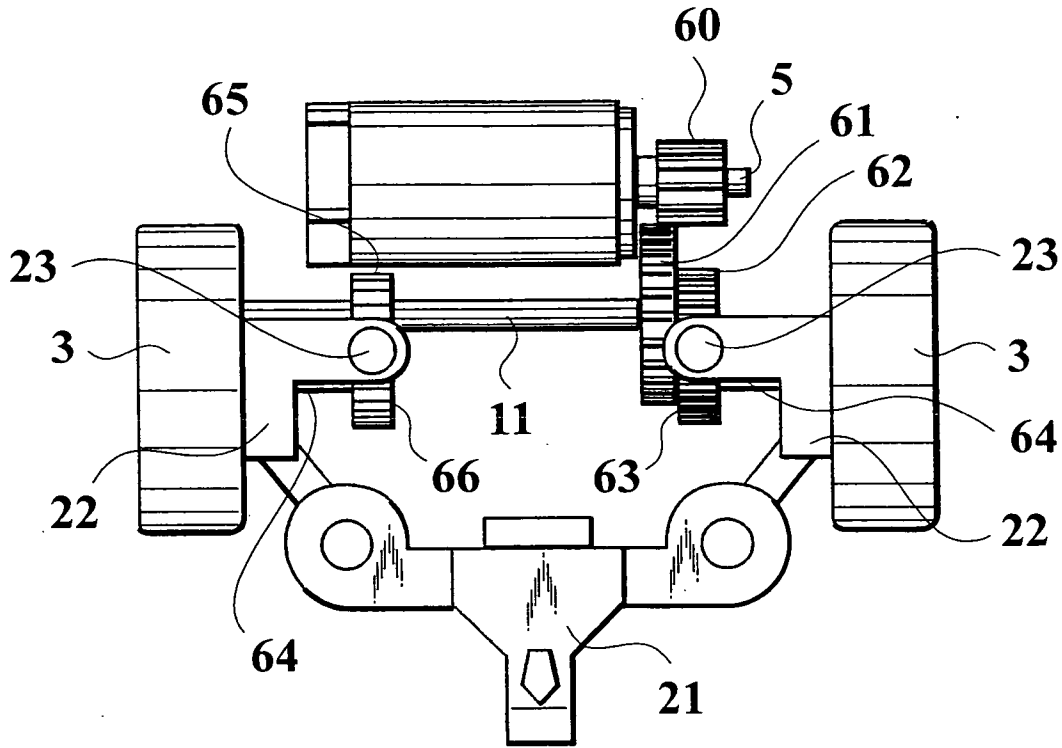
**FIG. 8**



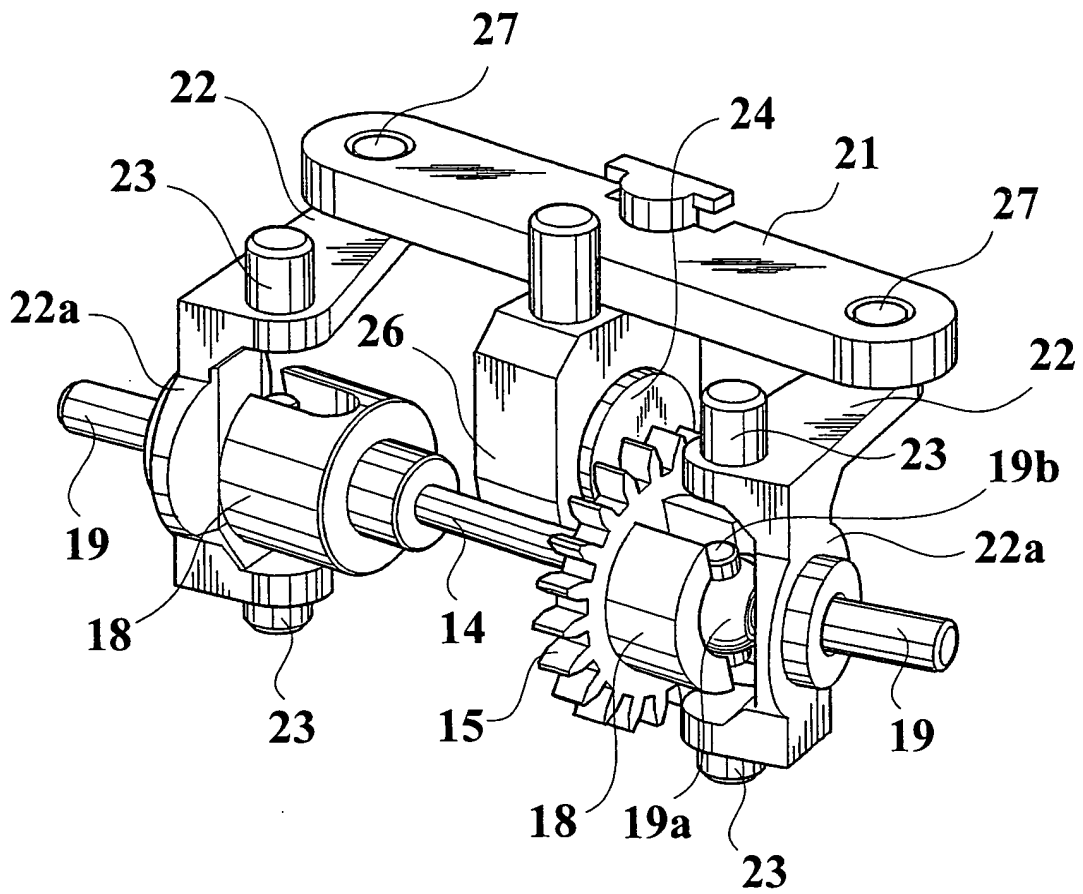
**FIG 9**



**FIG 10**

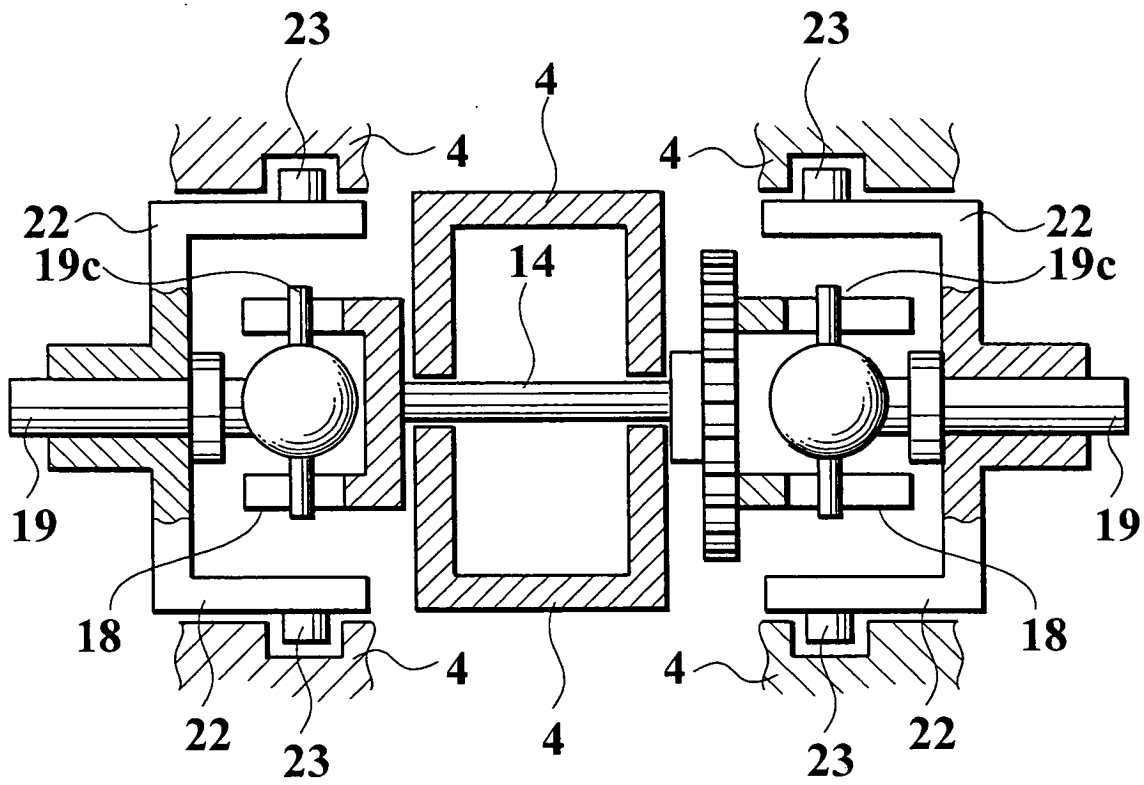


**FIG 11**

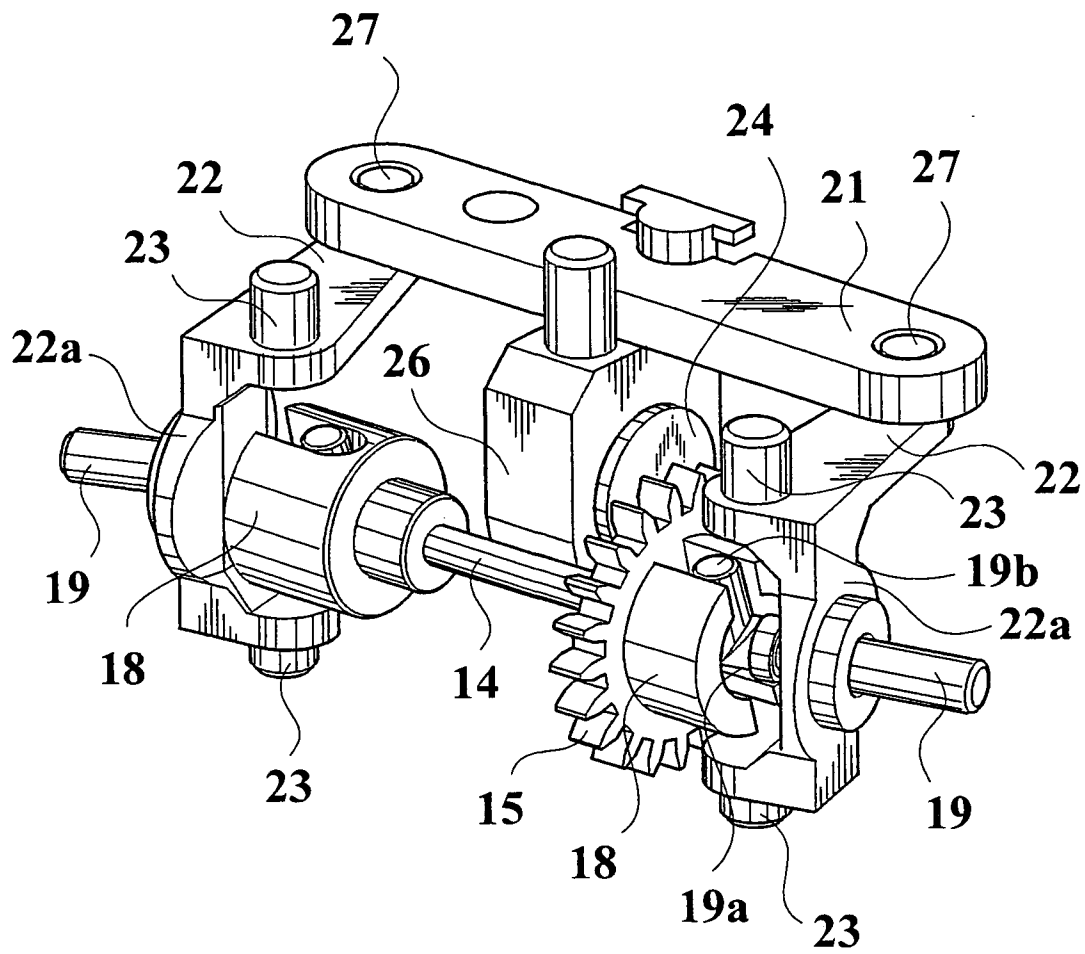




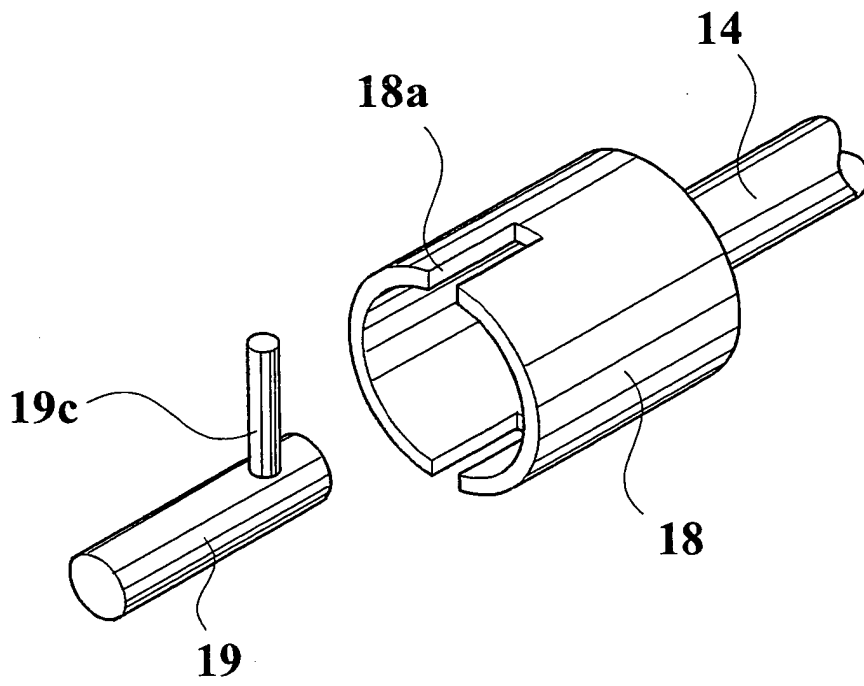
**FIG. 12**



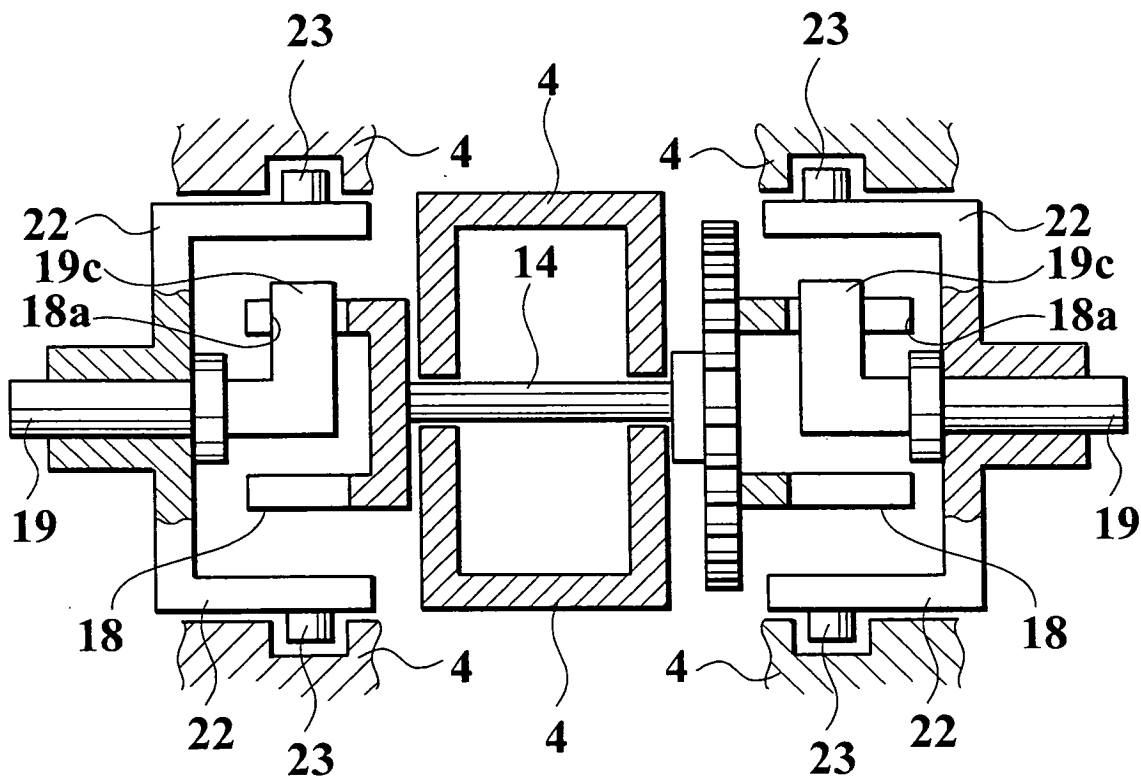
**FIG 13**



**FIG. 14**



**FIG.15**





European Patent  
Office

EUROPEAN SEARCH REPORT

Application Number  
EP 04 25 0654

DOCUMENTS CONSIDERED TO BE RELEVANT			
Category	Citation of document with indication, where appropriate, of relevant passages	Relevant to claim	CLASSIFICATION OF THE APPLICATION (Int.Cl.7)
X	DE 969 230 C (MAX ERNST) 14 May 1958 (1958-05-14) * page 2, line 43-109; figures 1-4 * ---	1,2	A63H30/04 A63H33/04 A63H31/00 A63H31/08
X	EP 0 750 929 A (NIKKO KK) 2 January 1997 (1997-01-02) * column 6, line 54 - column 7, line 14; figure 1 * ---	1,2,11	A63H29/00 A63H17/395 A63H17/36 A63H17/26
Y	US 4 889 516 A (AUER ROBERT T ET AL) 26 December 1989 (1989-12-26) * column 3, line 16 - column 5, line 20; figures 1,2,6 * ---	1-4,11	
Y	US 4 406 085 A (RHODES TONY) 27 September 1983 (1983-09-27) * column 3, line 13 - column 6, line 30; figures 1-6 * ---	1-4,11	
A	US 4 878 877 A (AUER ROBERT T ET AL) 7 November 1989 (1989-11-07) * column 3, line 64 - column 6, line 64; figures 1-10 * ---	1-4,11	TECHNICAL FIELDS SEARCHED (Int.Cl.7) A63H
A	US 4 764 150 A (UCHINO SHIGEO) 16 August 1988 (1988-08-16) * the whole document * -----	1-11	
The present search report has been drawn up for all claims			
Place of search MUNICH		Date of completion of the search 27 April 2004	Examiner Brumme, I
CATEGORY OF CITED DOCUMENTS X : particularly relevant if taken alone Y : particularly relevant if combined with another document of the same category A : technological background O : non-written disclosure P : intermediate document		T : theory or principle underlying the invention E : earlier patent document, but published on, or after the filing date D : document cited in the application L : document cited for other reasons ..... & : member of the same patent family, corresponding document	

EPO FORM 1503 03.82 (P04C01)

ANNEX TO THE EUROPEAN SEARCH REPORT  
ON EUROPEAN PATENT APPLICATION NO.

EP 04 25 0654

This annex lists the patent family members relating to the patent documents cited in the above-mentioned European search report. The members are as contained in the European Patent Office EDP file on  
The European Patent Office is in no way liable for these particulars which are merely given for the purpose of information.

27-04-2004

Patent document cited in search report		Publication date	Patent family member(s)	Publication date
DE 969230	C	14-05-1958	NONE	
EP 0750929	A	02-01-1997	JP 9010445 A	14-01-1997
			DE 69611705 D1	08-03-2001
			DE 69611705 T2	09-08-2001
			EP 0750929 A2	02-01-1997
			NO 962753 A	30-12-1996
			US 5722873 A	03-03-1998
US 4889516	A	26-12-1989	US 4878877 A	07-11-1989
US 4406085	A	27-09-1983	NONE	
US 4878877	A	07-11-1989	US 4889516 A	26-12-1989
US 4764150	A	16-08-1988	NONE	

EPO FORM P0459

For more details about this annex : see Official Journal of the European Patent Office, No. 12/82