



US 20060028446A1

(19) **United States**

(12) **Patent Application Publication**

**Liberty et al.**

(10) **Pub. No.: US 2006/0028446 A1**

(43) **Pub. Date: Feb. 9, 2006**

(54) **METHODS AND DEVICES FOR REMOVING UNINTENTIONAL MOVEMENT IN FREE SPACE POINTING DEVICES**

(75) Inventors: **Matthew G. Liberty**, Potomac, MD (US); **Frank A. Hunleth**, Rockville, MD (US)

Correspondence Address:  
**Steven M. duBois**  
**Potomac Patent Group, PLLC**  
**P.O. Box 270**  
**Fredericksburg, VA 22404 (US)**

(73) Assignee: **Hillcrest Communications, Inc.**, Rockville, MD

(21) Appl. No.: **11/119,987**

(22) Filed: **May 2, 2005**

**Related U.S. Application Data**

(60) Provisional application No. 60/566,444, filed on Apr. 30, 2004. Provisional application No. 60/612,571, filed on Sep. 23, 2004. Provisional application No. 60/641,383, filed on Jan. 5, 2005.

**Publication Classification**

(51) **Int. Cl.**  
**G09G 5/08** (2006.01)  
(52) **U.S. Cl.** ..... **345/158**

(57) **ABSTRACT**

Systems and methods according to the present invention describe free space pointing devices and methods which detect movement of the free space pointing device and remove unintentional movement from the output readings.

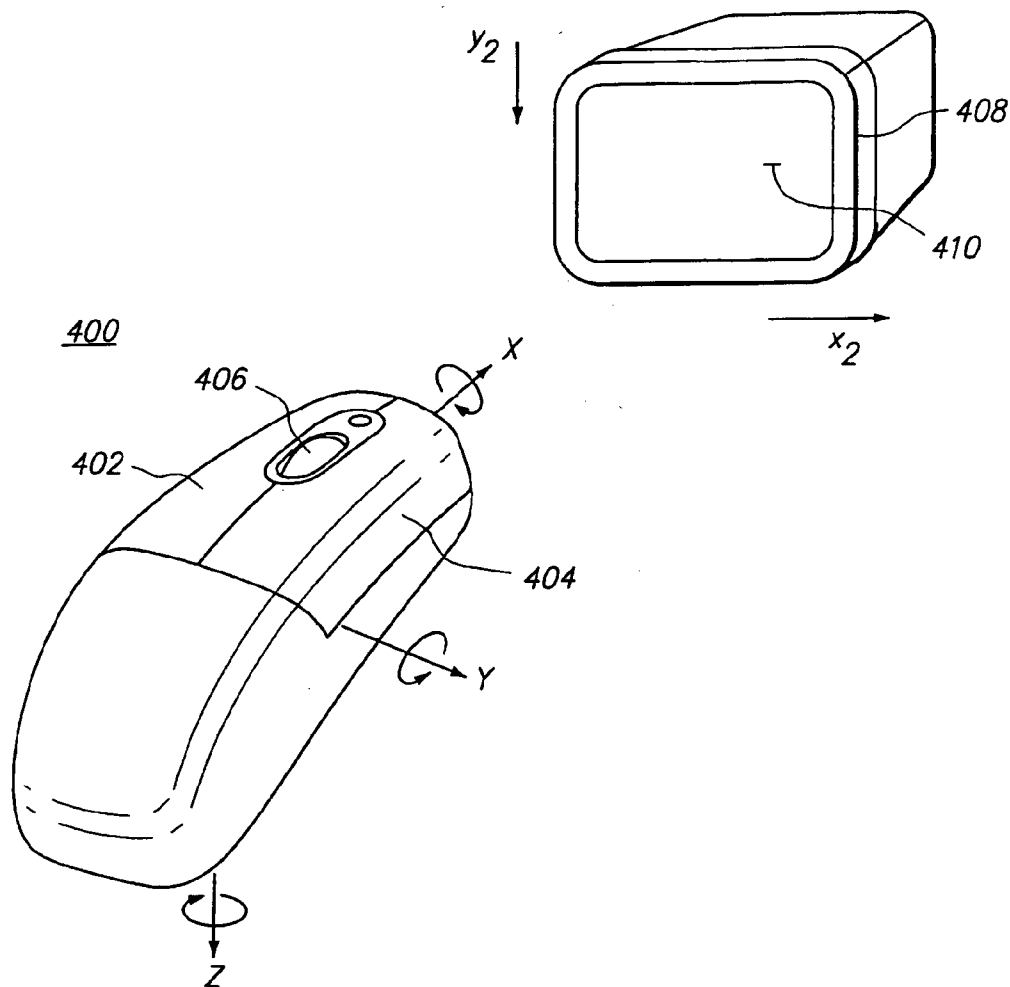

**FIG. 1**  
(Prior Art)

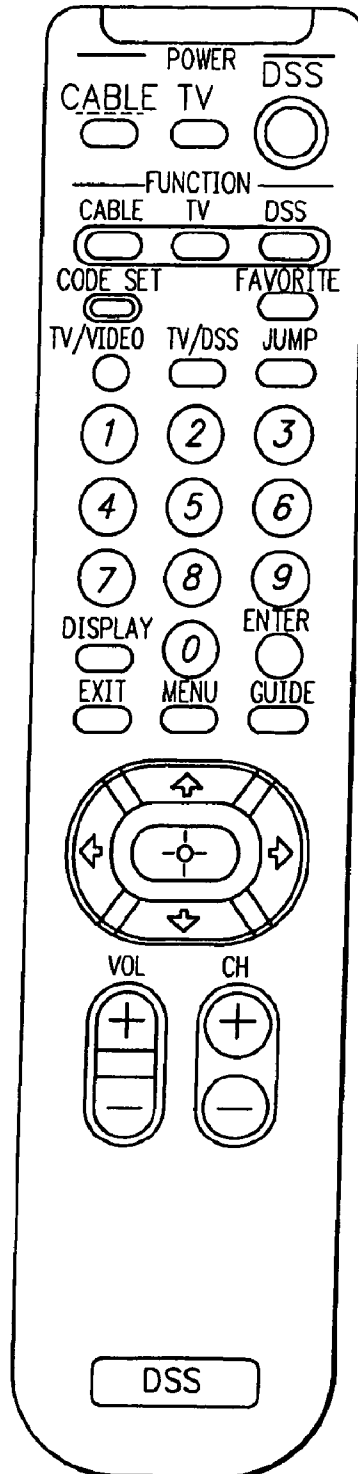

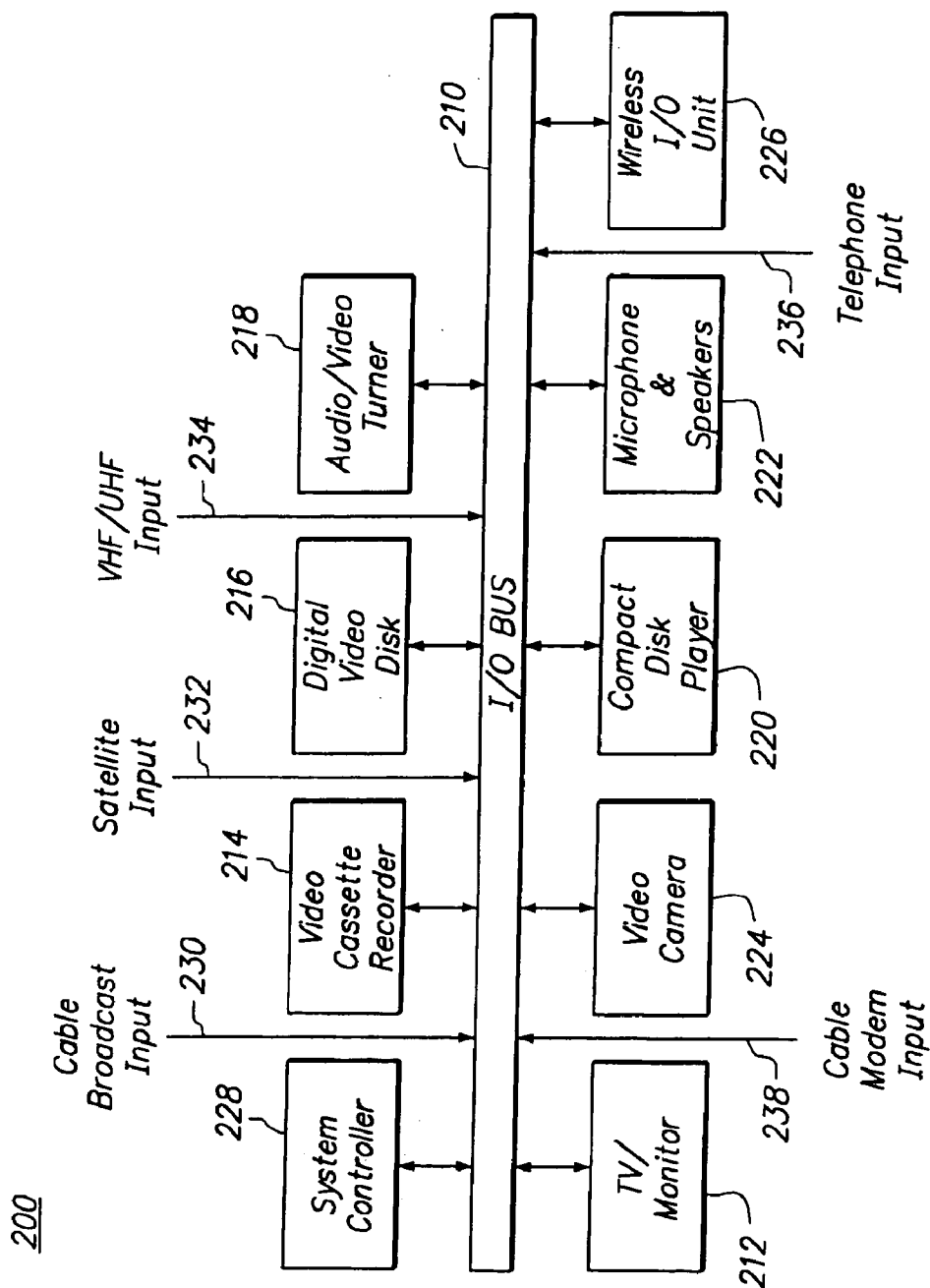

FIG. 2

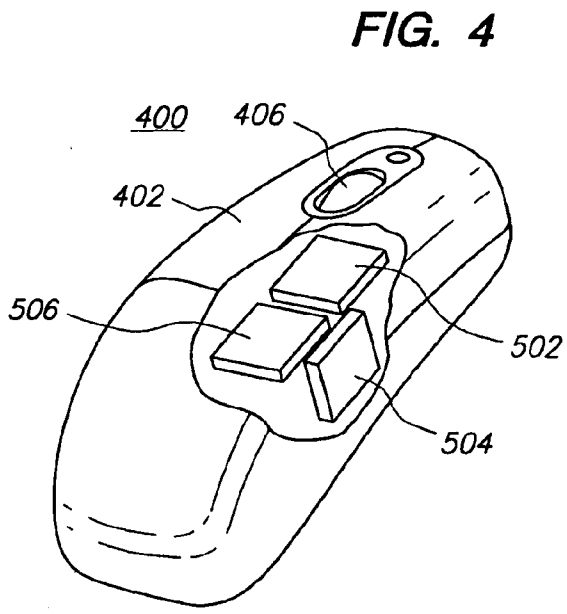
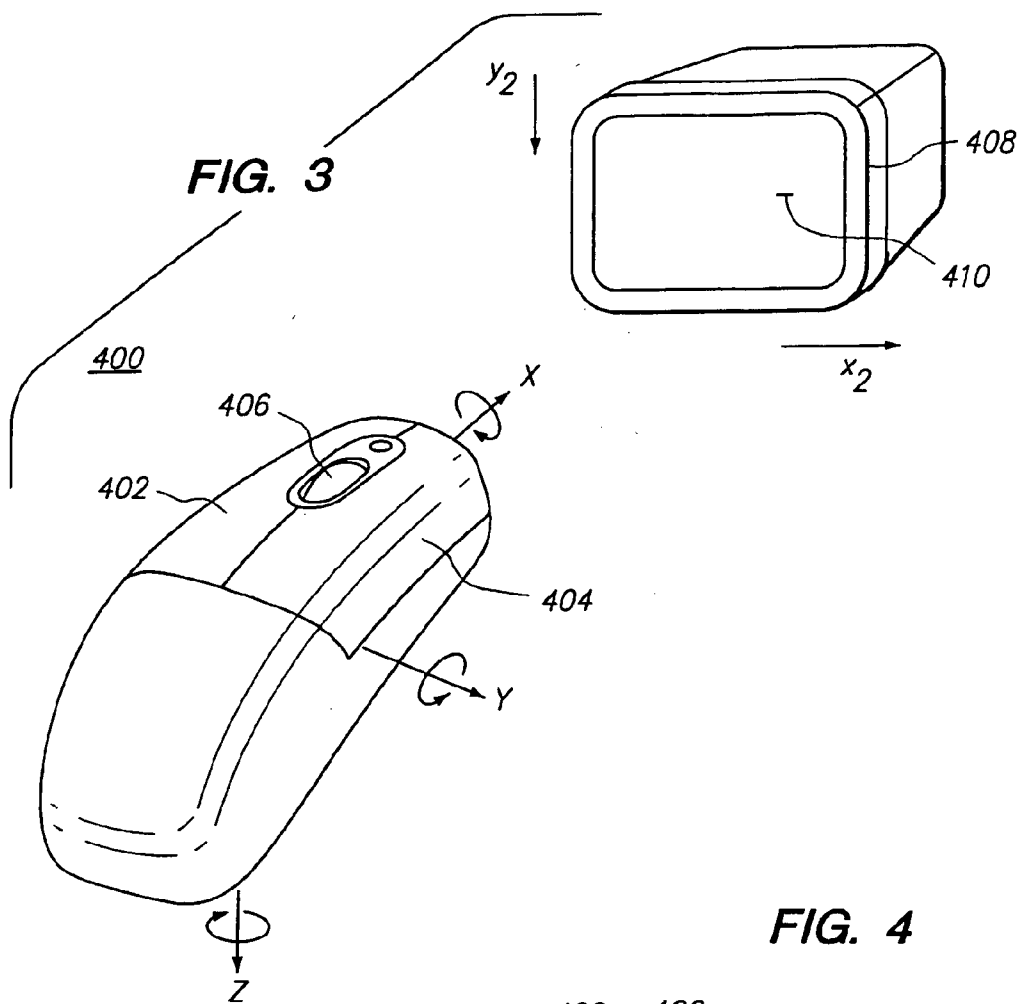
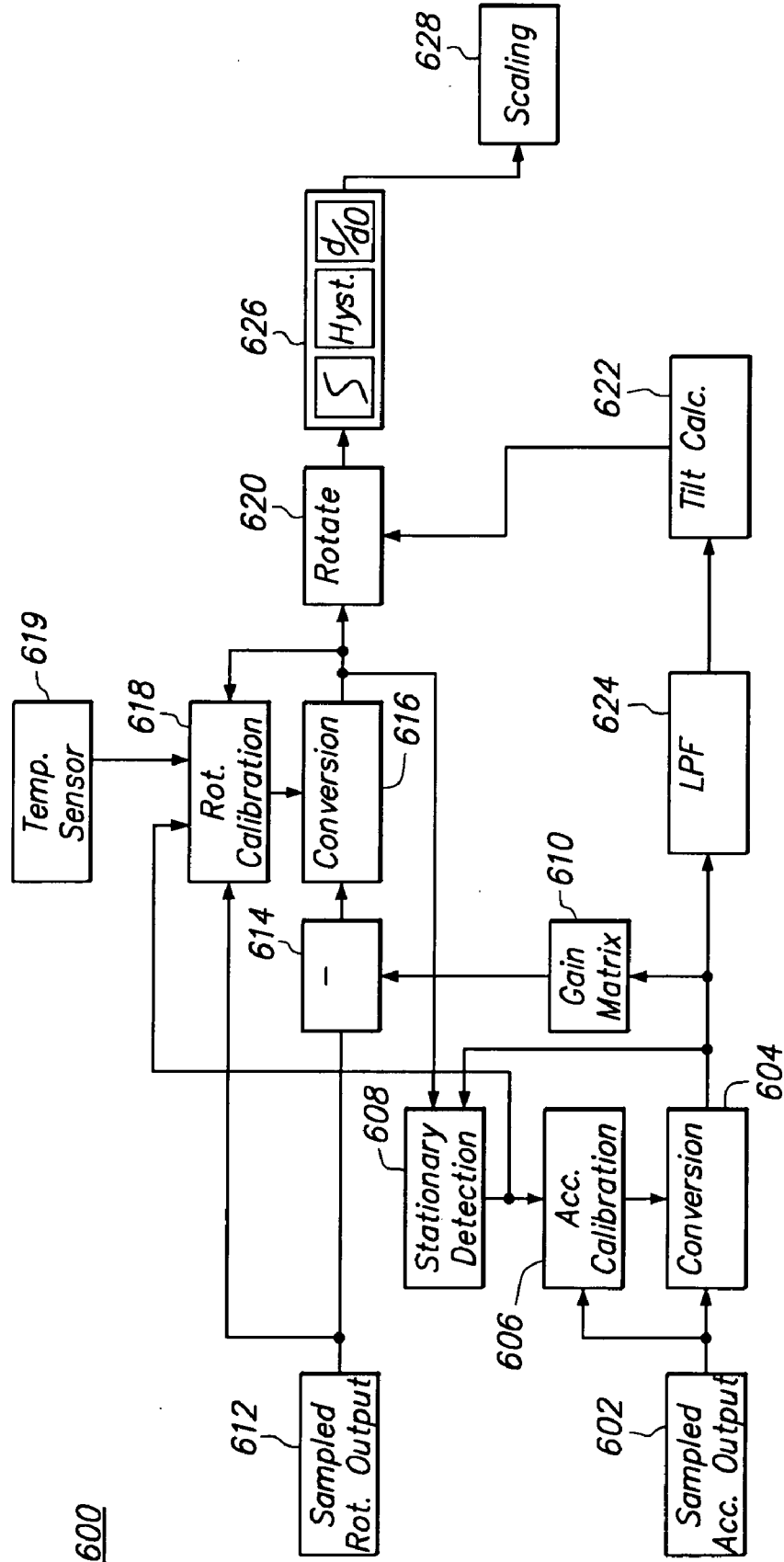
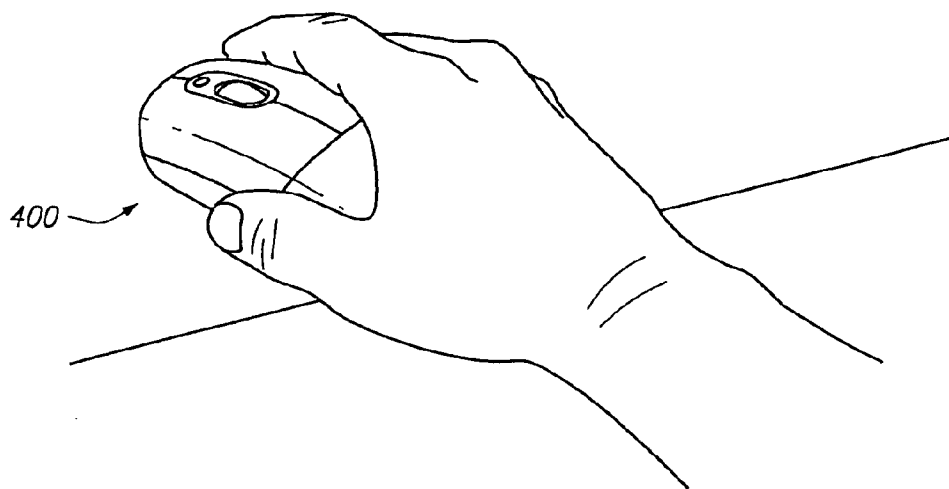

FIG. 5



**FIG. 6A**



**FIG. 6B**

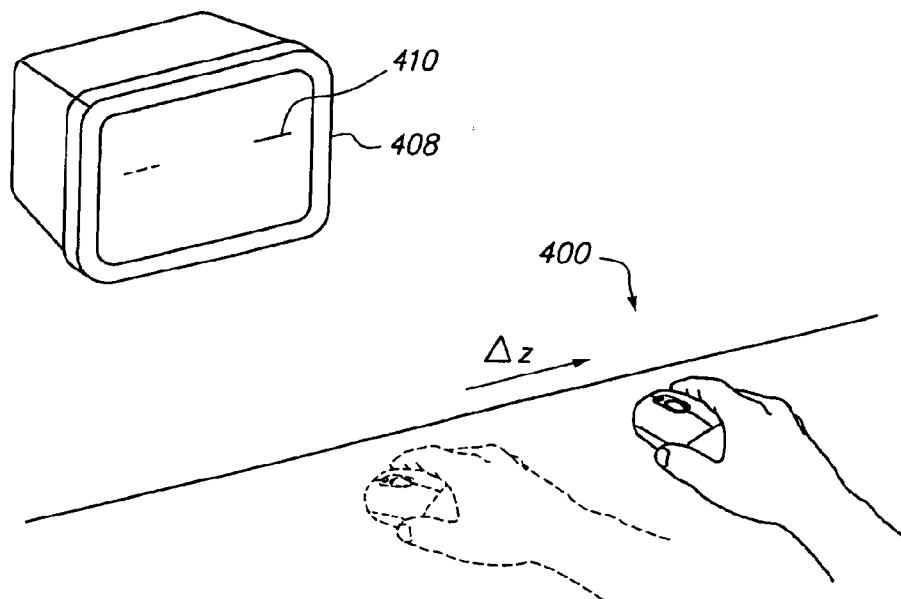

**FIG. 6C**

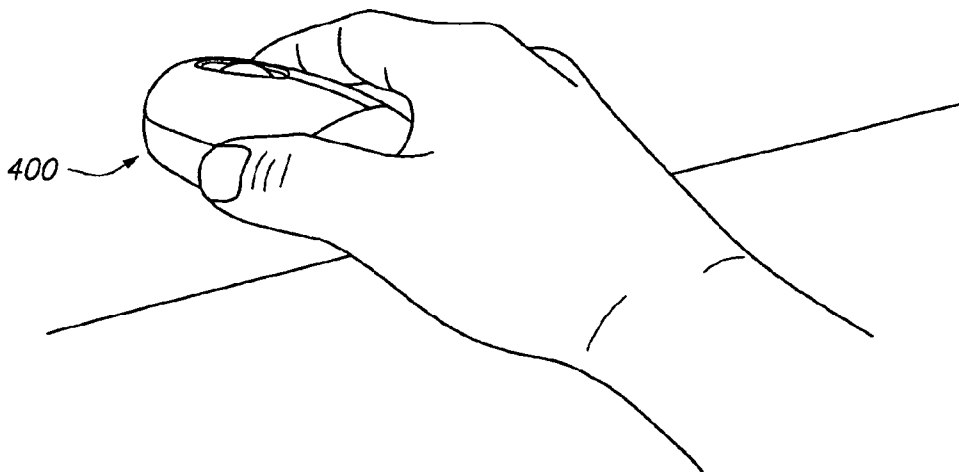

**FIG. 6D**

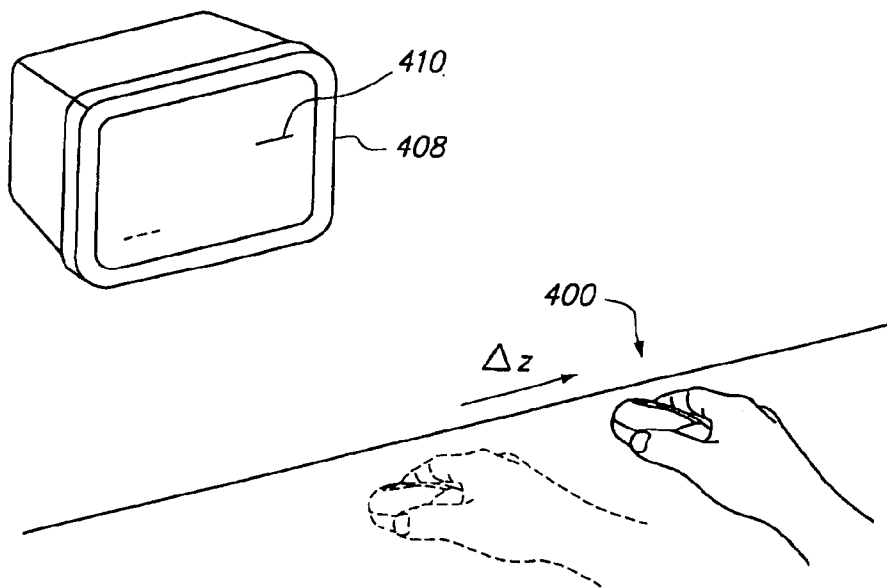
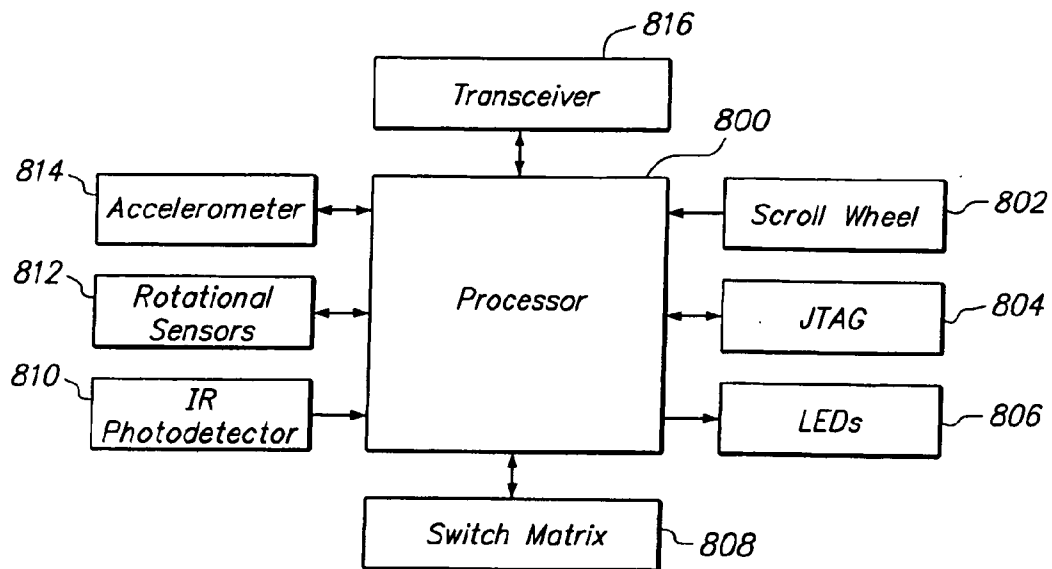
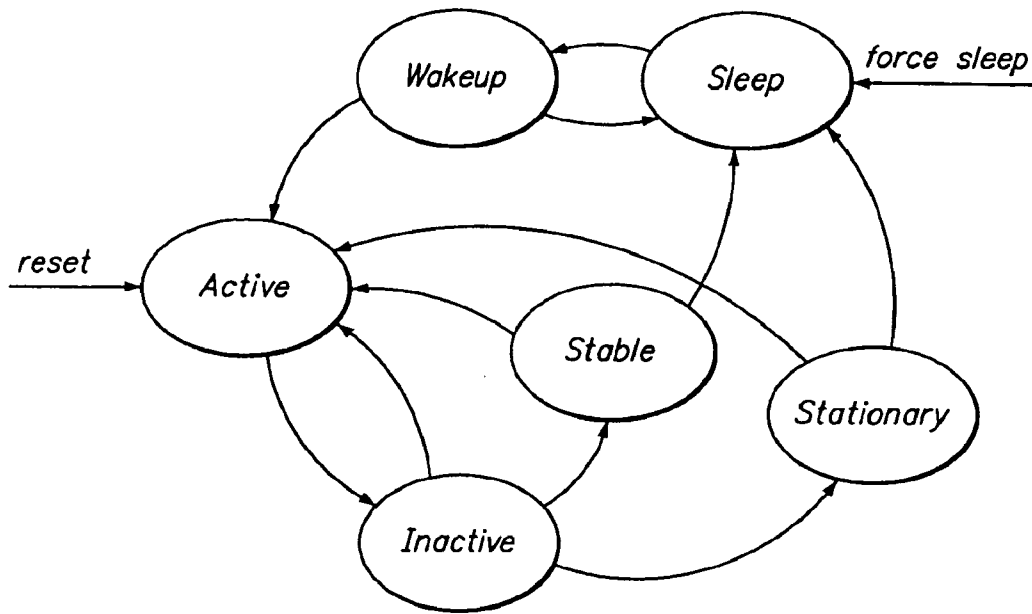

FIG. 7







**FIG. 8**

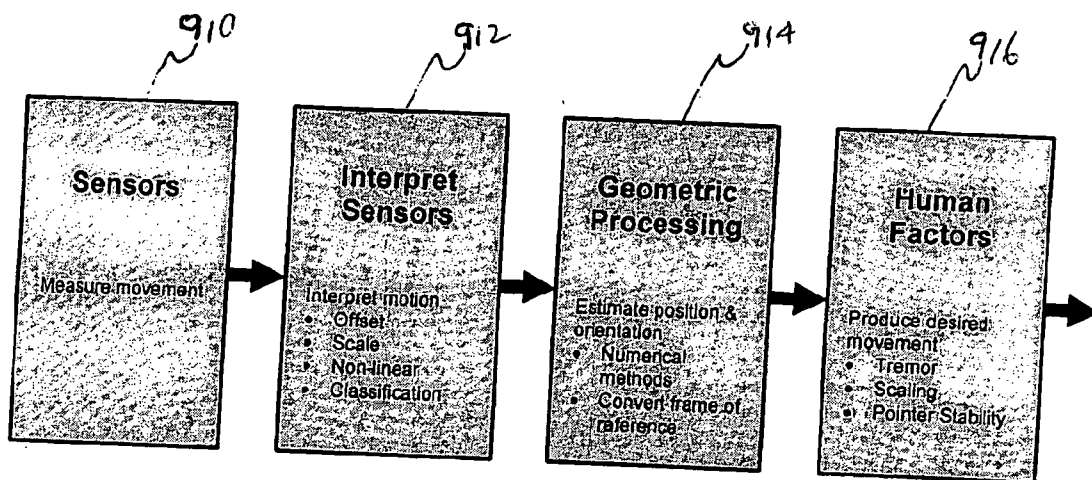

FIG. 9

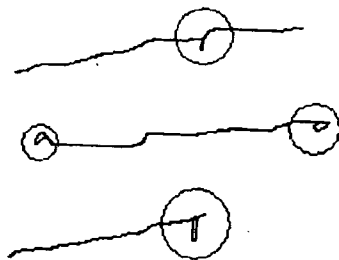

FIG. 10

**METHODS AND DEVICES FOR REMOVING  
UNINTENTIONAL MOVEMENT IN FREE SPACE  
POINTING DEVICES**

RELATED APPLICATIONS

[0001] This application is related to, and claims priority from, U.S. Provisional Patent Application Ser. No. 60/566,444 filed on Apr. 30, 2004, entitled "Freespace Pointing Device", the disclosure of which is incorporated here by reference. This application is also related to, and claims priority from, U.S. Provisional Patent Application Ser. No. 60/612,571, filed on Sep. 23, 2004, entitled "Free Space Pointing Devices and Methods", the disclosure of which is incorporated here by reference. This application is also related to, and claims priority from, U.S. Provisional Patent Application Ser. No. 60/641,383, filed on Jan. 5, 2005, entitled "Methods and Devices for Removing Unintentional Movement in Free Space Pointing Devices", the disclosure of which is incorporated here by reference. This application is also related to U.S. patent applications Ser. Nos. \_\_\_\_\_, \_\_\_\_\_, and \_\_\_\_\_, entitled "Free Space Pointing Devices With Tilt Compensation and Improved Usability", "Methods and Devices for Identifying Users Based on Tremor", and "Free Space Pointing Devices and Methods", all of which were filed concurrently here with and all of which are incorporated here by reference.

BACKGROUND

[0002] The present invention describes techniques and devices for processing motion data associated with a device, e.g., a handheld device, to remove unintentional movement associated therewith. According to some exemplary embodiments of the present invention, the handheld device can be a free space pointing device.

[0003] Technologies associated with the communication of information have evolved rapidly over the last several decades. Television, cellular telephony, the Internet and optical communication techniques (to name just a few things) combine to inundate consumers with available information and entertainment options. Taking television as an example, the last three decades have seen the introduction of cable television service, satellite television service, pay-per-view movies and video-on-demand. Whereas television viewers of the 1960s could typically receive perhaps four or five over-the-air TV channels on their television sets, today's TV watchers have the opportunity to select from hundreds, thousands, and potentially millions of channels of shows and information. Video-on-demand technology, currently used primarily in hotels and the like, provides the potential for in-home entertainment selection from among thousands of movie titles.

[0004] The technological ability to provide so much information and content to end users provides both opportunities and challenges to system designers and service providers. One challenge is that while end users typically prefer having more choices rather than fewer, this preference is counter-weighted by their desire that the selection process be both fast and simple. Unfortunately, the development of the systems and interfaces by which end users access media items has resulted in selection processes which are neither fast nor simple. Consider again the example of television programs. When television was in its infancy, determining

which program to watch was a relatively simple process primarily due to the small number of choices. One would consult a printed guide which was formatted, for example, as series of columns and rows which showed the correspondence between (1) nearby television channels, (2) programs being transmitted on those channels and (3) date and time. The television was tuned to the desired channel by adjusting a tuner knob and the viewer watched the selected program. Later, remote control devices were introduced that permitted viewers to tune the television from a distance. This addition to the user-television interface created the phenomenon known as "channel surfing" whereby a viewer could rapidly view short segments being broadcast on a number of channels to quickly learn what programs were available at any given time.

[0005] Despite the fact that the number of channels and amount of viewable content has dramatically increased, the generally available user interface, control device options and frameworks for televisions has not changed much over the last 30 years. Printed guides are still the most prevalent mechanism for conveying programming information. The multiple button remote control with up and down arrows is still the most prevalent channel/content selection mechanism. The reaction of those who design and implement the TV user interface to the increase in available media content has been a straightforward extension of the existing selection procedures and interface objects. Thus, the number of rows in the printed guides has been increased to accommodate more channels. The number of buttons on the remote control devices has been increased to support additional functionality and content handling, e.g., as shown in FIG. 1. However, this approach has significantly increased both the time required for a viewer to review the available information and the complexity of actions required to implement a selection. Arguably, the cumbersome nature of the existing interface has hampered commercial implementation of some services, e.g., video-on-demand, since consumers are resistant to new services that will add complexity to an interface that they view as already too slow and complex.

[0006] In addition to increases in bandwidth and content, the user interface bottleneck problem is being exacerbated by the aggregation of technologies. Consumers are reacting positively to having the option of buying integrated systems rather than a number of segregable components. An example of this trend is the combination television/VCR/DVD in which three previously independent components are frequently sold today as an integrated unit. This trend is likely to continue, potentially with an end result that most if not all of the communication devices currently found in the household will be packaged together as an integrated unit, e.g., a television/VCR/DVD/internet access/radio/stereo unit. Even those who continue to buy separate components will likely desire seamless control of, and interworking between, the separate components. With this increased aggregation comes the potential for more complexity in the user interface. For example, when so-called "universal" remote units were introduced, e.g., to combine the functionality of TV remote units and VCR remote units, the number of buttons on these universal remote units was typically more than the number of buttons on either the TV remote unit or VCR remote unit individually. This added number of buttons and functionality makes it very difficult to control anything but the simplest aspects of a TV or VCR without hunting for exactly the right button on the remote. Many times, these

universal remotes do not provide enough buttons to access many levels of control or features unique to certain TVs. In these cases, the original device remote unit is still needed, and the original hassle of handling multiple remotes remains due to user interface issues arising from the complexity of aggregation. Some remote units have addressed this problem by adding "soft" buttons that can be programmed with the expert commands. These soft buttons sometimes have accompanying LCD displays to indicate their action. These too have the flaw that they are difficult to use without looking away from the TV to the remote control. Yet another flaw in these remote units is the use of modes in an attempt to reduce the number of buttons. In these "moded" universal remote units, a special button exists to select whether the remote should communicate with the TV, DVD player, cable set-top box, VCR, etc. This causes many usability issues including sending commands to the wrong device, forcing the user to look at the remote to make sure that it is in the right mode, and it does not provide any simplification to the integration of multiple devices. The most advanced of these universal remote units provide some integration by allowing the user to program sequences of commands to multiple devices into the remote. This is such a difficult task that many users hire professional installers to program their universal remote units.

[0007] Some attempts have also been made to modernize the screen interface between end users and media systems. However, these attempts typically suffer from, among other drawbacks, an inability to easily scale between large collections of media items and small collections of media items. For example, interfaces which rely on lists of items may work well for small collections of media items, but are tedious to browse for large collections of media items. Interfaces which rely on hierarchical navigation (e.g., tree structures) may be speedier to traverse than list interfaces for large collections of media items, but are not readily adaptable to small collections of media items. Additionally, users tend to lose interest in selection processes wherein the user has to move through three or more layers in a tree structure. For all of these cases, current remote units make this selection processor even more tedious by forcing the user to repeatedly depress the up and down buttons to navigate the list or hierarchies. When selection skipping controls are available such as page up and page down, the user usually has to look at the remote to find these special buttons or be trained to know that they even exist. Accordingly, organizing frameworks, techniques and systems which simplify the control and screen interface between users and media systems as well as accelerate the selection process, while at the same time permitting service providers to take advantage of the increases in available bandwidth to end user equipment by facilitating the supply of a large number of media items and new services to the user have been proposed in U.S. patent application Ser. No. 10/768,432, filed on Jan. 30, 2004, entitled "A Control Framework with a Zoomable Graphical User Interface for Organizing, Selecting and Launching Media Items", the disclosure of which is incorporated here by reference.

[0008] Of particular interest for this specification are the remote devices usable to interact with such frameworks, as well as other applications and systems. As mentioned in the above-incorporated application, various different types of remote devices can be used with such frameworks including, for example, trackballs, "mouse"-type pointing devices,

light pens, etc. However, another category of remote devices which can be used with such frameworks (and other applications) is free space pointing devices. The phrase "free space pointing" is used in this specification to refer to the ability of an input device to move in three (or more) dimensions in the air in front of, e.g., a display screen, and the corresponding ability of the user interface to translate those motions directly into user interface commands, e.g., movement of a cursor on the display screen. The transfer of data between the free space pointing device may be performed wirelessly or via a wire connecting the free space pointing device to another device. Thus "free space pointing" differs from, e.g., conventional computer mouse pointing techniques which use a surface, e.g., a desk surface or mousepad, as a proxy surface from which relative movement of the mouse is translated into cursor movement on the computer display screen. An example of a free space pointing device can be found in U.S. Pat. No. 5,440,326.

[0009] The '326 patent describes, among other things, a vertical gyroscope adapted for use as a pointing device for controlling the position of a cursor on the display of a computer. A motor at the core of the gyroscope is suspended by two pairs of orthogonal gimbals from a hand-held controller device and nominally oriented with its spin axis vertical by a pendulous device. Electro-optical shaft angle encoders sense the orientation of a hand-held controller device as it is manipulated by a user and the resulting electrical output is converted into a format usable by a computer to control the movement of a cursor on the screen of the computer display.

[0010] However, the freedom of use associated with free-space pointers creates additional challenges. For example, when a button is pressed on a free-space pointing device, the button actuation causes undesirable movement of the device that should not be translated into pointer movement. One technique for addressing a portion of this problem is to use a distance threshold to reactivate pointer movement after a button press occurs, i.e., to ignore any movement of the pointer after a button press occurs until the free space pointing device moves a predetermined distance. While simple, this technique may ignore intended movements of the device as well as unintended movements.

[0011] Accordingly, the present invention describes, among other things, methods and devices for processing pointer data on button clicks and other actions to remove undesirable movement without eliminating intended movement.

#### SUMMARY

[0012] According to one exemplary embodiment of the present invention, a method for operating a free space pointing device includes the steps of sensing movement of the free space pointing device and generating an output associated therewith, detecting occurrence of an event, determining a velocity of the free space pointing device, if the velocity of the free space pointing device is below a predetermined velocity threshold, then discarding or attenuating movement information sensed after the detected occurrence of the event and otherwise, if the velocity of the free space pointing device is above the predetermined velocity threshold, then filtering movement information sensed after the detected occurrence of the event to remove unintended motion associated with the user-initiated event.

[0013] According to another exemplary embodiment of the present invention, a method for operating a free space pointing device includes the steps of sensing movement of the free space pointing device and generating an output associated therewith, detecting occurrence of an event and discarding or attenuating the output until a predetermined time has elapsed after the detection of the event.

[0014] According to yet another exemplary embodiment of the present invention, a method for operating a free space pointing device includes the steps of sensing movement of the free space pointing device and generating an output associated therewith, detecting occurrence of an event and filtering the output based on the detected event.

[0015] According to a still further exemplary embodiment of the present invention, a handheld pointing device includes at least one motion sensor for sensing movement of the handheld pointing device and generating an output associated therewith and a processing unit for detecting occurrence of an event and discarding or attenuating the output until either a predetermined time has elapsed after the detection of the event or the handheld pointing device has moved a predetermined distance after the detection of the event, whichever comes first.

#### BRIEF DESCRIPTION OF THE DRAWINGS

[0016] The accompanying drawings illustrate exemplary embodiments of the present invention, wherein:

[0017] **FIG. 1** depicts a conventional remote control unit for an entertainment system;

[0018] **FIG. 2** depicts an exemplary media system in which exemplary embodiments of the present invention can be implemented;

[0019] **FIG. 3** shows a free space pointing device according to an exemplary embodiment of the present invention;

[0020] **FIG. 4** illustrates a cutaway view of the free space pointing device in **FIG. 4** including two rotational sensors and one accelerometer;

[0021] **FIG. 5** is a block diagram illustrating processing of data associated with free space pointing devices according to an exemplary embodiment of the present invention;

[0022] **FIGS. 6(a)-6(d)** illustrate the effects of tilt;

[0023] **FIG. 7** depicts a hardware architecture of a free space pointing device according to an exemplary embodiment of the present invention;

[0024] **FIG. 8** is a state diagram depicting a stationary detection mechanism according to an exemplary embodiment of the present invention;

[0025] **FIG. 9** is a block diagram illustrating a system for removing unintentional movement from detected motion according to an exemplary embodiment of the present invention; and

[0026] **FIG. 10** depicts various examples of detected movement associated with fine button clicking and coarse button clicking.

#### DETAILED DESCRIPTION

[0027] The following detailed description of the invention refers to the accompanying drawings. The same reference

numbers in different drawings identify the same or similar elements. Also, the following detailed description does not limit the invention. Instead, the scope of the invention is defined by the appended claims.

[0028] In order to provide some context for this discussion, an exemplary aggregated media system **200** in which the present invention can be implemented will first be described with respect to **FIG. 2**. Those skilled in the art will appreciate, however, that the present invention is not restricted to implementation in this type of media system and that more or fewer components can be included therein. Therein, an input/output (I/O) bus **210** connects the system components in the media system **200** together. The I/O bus **210** represents any of a number of different of mechanisms and techniques for routing signals between the media system components. For example, the I/O bus **210** may include an appropriate number of independent audio “patch” cables that route audio signals, coaxial cables that route video signals, two-wire serial lines or infrared or radio frequency transceivers that route control signals, optical fiber or any other routing mechanisms that route other types of signals.

[0029] In this exemplary embodiment, the media system **200** includes a television/monitor **212**, a video cassette recorder (VCR) **214**, digital video disk (DVD) recorder/playback device **216**, audio/video tuner **218** and compact disk player **220** coupled to the I/O bus **210**. The VCR **214**, DVD **216** and compact disk player **220** may be single disk or single cassette devices, or alternatively may be multiple disk or multiple cassette devices. They may be independent units or integrated together. In addition, the media system **200** includes a microphone/speaker system **222**, video camera **224** and a wireless I/O control device **226**. According to exemplary embodiments of the present invention, the wireless I/O control device **226** is a free space pointing device according to one of the exemplary embodiments described below. The wireless I/O control device **226** can communicate with the entertainment system **200** using, e.g., an IR or RF transmitter or transceiver. Alternatively, the I/O control device can be connected to the entertainment system **200** via a wire.

[0030] The entertainment system **200** also includes a system controller **228**. According to one exemplary embodiment of the present invention, the system controller **228** operates to store and display entertainment system data available from a plurality of entertainment system data sources and to control a wide variety of features associated with each of the system components. As shown in **FIG. 2**, system controller **228** is coupled, either directly or indirectly, to each of the system components, as necessary, through I/O bus **210**. In one exemplary embodiment, in addition to or in place of I/O bus **210**, system controller **228** is configured with a wireless communication transmitter (or transceiver), which is capable of communicating with the system components via IR signals or RF signals. Regardless of the control medium, the system controller **228** is configured to control the media components of the media system **200** via a graphical user interface described below.

[0031] As further illustrated in **FIG. 2**, media system **200** may be configured to receive media items from various media sources and service providers. In this exemplary embodiment, media system **200** receives media input from and, optionally, sends information to, any or all of the

following sources: cable broadcast **230**, satellite broadcast **232** (e.g., via a satellite dish), very high frequency (VHF) or ultra high frequency (UHF) radio frequency communication of the broadcast television networks **234** (e.g., via an aerial antenna), telephone network **236** and cable modem **238** (or another source of Internet content). Those skilled in the art will appreciate that the media components and media sources illustrated and described with respect to **FIG. 2** are purely exemplary and that media system **200** may include more or fewer of both. For example, other types of inputs to the system include AM/FM radio and satellite radio.

[0032] More details regarding this exemplary entertainment system and frameworks associated therewith can be found in the above-incorporated by reference U.S. patent application Ser. No. \_\_\_\_\_ "A Control Framework with a Zoomable Graphical User Interface for Organizing, Selecting and Launching Media Items". Alternatively, remote devices in accordance with the present invention can be used in conjunction with other systems, for example computer systems including, e.g., a display, a processor and a memory system or with various other systems and applications.

[0033] As mentioned in the Background section, remote devices which operate as free space pointers are of particular interest for the present specification. Such devices enable the translation of movement, e.g., gestures, into commands to a user interface. An exemplary free space pointing device **400** is depicted in **FIG. 3**. Therein, user movement of the free space pointing can be defined, for example, in terms of a combination of x-axis attitude (roll), y-axis elevation (pitch) and/or z-axis heading (yaw) motion of the free space pointing device **400**. In addition, some exemplary embodiments of the present invention can also measure linear movement of the free space pointing device **400** along the x, y, and z axes to generate cursor movement or other user interface commands. In the exemplary embodiment of **FIG. 3**, the free space pointing device **400** includes two buttons **402** and **404** as well as a scroll wheel **406**, although other exemplary embodiments will include other physical configurations. According to exemplary embodiments of the present invention, it is anticipated that free space pointing devices **400** will be held by a user in front of a display **408** and that motion of the free space pointing device **400** will be translated by the free space pointing device into output which is usable to interact with the information displayed on display **408**, e.g., to move the cursor **410** on the display **408**. For example, rotation of the free space pointing device **400** about the y-axis can be sensed by the free space pointing device **400** and translated into an output usable by the system to move cursor **410** along the  $y_2$  axis of the display **408**. Likewise, rotation of the free space pointing device **408** about the z-axis can be sensed by the free space pointing device **400** and translated into an output usable by the system to move cursor **410** along the  $x_2$  axis of the display **408**. It will be appreciated that the output of free space pointing device **400** can be used to interact with the display **408** in a number of ways other than (or in addition to) cursor movement, for example it can control cursor fading, volume or media transport (play, pause, fast-forward and rewind). Input commands may include operations in addition to cursor movement, for example, a zoom in or zoom out on a particular region of a display. A cursor may or may not be visible. Similarly, rotation of the free space pointing device **400** sensed about the x-axis of free space pointing device

**400** can be used in addition to, or as an alternative to, y-axis and/or z-axis rotation to provide input to a user interface.

[0034] According to one exemplary embodiment of the present invention, two rotational sensors **502** and **504** and one accelerometer **506** can be employed as sensors in free space pointing device **400** as shown in **FIG. 4**. The rotational sensors **502** and **504** can, for example, be implemented using ADXRS150 or ADXRS401 sensors made by Analog Devices. It will be appreciated by those skilled in the art that other types of rotational sensors can be employed as rotational sensors **502** and **504** and that the ADXRS150 and ADXRS401 are purely used as an illustrative example. Unlike traditional gyroscopes, the ADXRS150 rotational sensors use MEMS technology to provide a resonating mass which is attached to a frame so that it can resonate only along one direction. The resonating mass is displaced when the body to which the sensor is affixed is rotated around the sensor's sensing axis. This displacement can be measured using the Coriolis acceleration effect to determine an angular velocity associated with rotation along the sensing axis. If the rotational sensors **502** and **504** have a single sensing axis (as for example the ADXRS150s), then they can be mounted in the free space pointing device **400** such that their sensing axes are aligned with the rotations to be measured. For this exemplary embodiment of the present invention, this means that rotational sensor **504** is mounted such that its sensing axis is parallel to the y-axis and that rotational sensor **502** is mounted such that its sensing axis is parallel to the z-axis as shown in **FIG. 4**. Note, however, that aligning the sensing axes of the rotational sensors **502** and **504** parallel to the desired measurement axes is not required since exemplary embodiments of the present invention also provide techniques for compensating for offset between axes.

[0035] One challenge faced in implementing exemplary free space pointing devices **400** in accordance with the present invention is to employ components, e.g., rotational sensors **502** and **504**, which are not too costly, while at the same time providing a high degree of correlation between movement of the free space pointing device **400**, a user's expectation regarding how the user interface will react to that particular movement of the free space pointing device and actual user interface performance in response to that movement. For example, if the free space pointing device **400** is not moving, the user will likely expect that the cursor ought not to be drifting across the screen. Likewise, if the user rotates the free space pointing device **400** purely around the y-axis, she or he would likely not expect to see the resulting cursor movement on display **408** contain any significant  $x_2$  axis component. To achieve these, and other, aspects of exemplary embodiments of the present invention, various measurements and calculations are performed by the handheld device **400** which are used to adjust the outputs of one or more of the sensors **502**, **504** and **506** and/or as part of the input used by a processor to determine an appropriate output for the user interface based on the outputs of the sensors **502**, **504** and **506**. These measurements and calculations are used to compensate for factors which fall broadly into two categories: (1) factors which are intrinsic to the free space pointing device **400**, e.g., errors associated with the particular sensors **502**, **504** and **506** used in the device **400** or the way in which the sensors are mounted in the device **400** and (2) factors which are not intrinsic to the free space pointing device **400**, but are instead associated with the manner in which a user is using the free space pointing

device 400, e.g., linear acceleration, tilt and tremor. Exemplary techniques for handling each of these effects are described below.

[0036] A process model 600 which describes the general operation of free space pointing devices according to exemplary embodiments of the present invention is illustrated in FIG. 5. The rotational sensors 502 and 504, as well as the accelerometer 506, produce analog signals which are sampled periodically, e.g., 200 samples/second. For the purposes of this discussion, a set of these inputs shall be referred to using the notation (x, y, z,  $\alpha_y$ ,  $\alpha_z$ ), wherein x, y, z are the sampled output values of the exemplary three-axis accelerometer 506 which are associated with acceleration of the free space pointing device in the x-axis, y-axis and z-axis directions, respectively,  $\alpha_y$  is a the sampled output value from rotational sensor 502 associated with the rotation of the free space pointing device about the y-axis and  $\alpha_z$  is the sampled output value from rotational sensor 504 associated with rotation of the free space pointing device 400 about the z-axis.

[0037] The output from the accelerometer 506 is provided and, if the accelerometer 506 provides analog output, then the output is sampled and digitized by an A/D converter (not shown) to generate sampled accelerometer output 602. The sampled output values are converted from raw units to units of acceleration, e.g., gravities (g), as indicated by conversion function 604. The acceleration calibration block 606 provides the values used for the conversion function 604. This calibration of the accelerometer output 602 can include, for example, compensation for one or more of scale, offset and axis misalignment error associated with the accelerometer 506. Exemplary conversions for the accelerometer data can be performed using the following equation:

$$A=S*((M-P).*G(T)) \tag{1}$$

wherein M is a 3x1 column vector composed of the sampled output values (x, y, z), P is a 3x1 column vector of sensor offsets, and S is a 3x3 matrix that contains both scale, axis misalignment, and sensor rotation compensation. G(T) is a gain factor that is a function of temperature. The “\*” operator represents matrix multiplication and the “.\*” operator represents element multiplication. The exemplary accelerometer 506 has an exemplary full range of +/-2 g. Sensor offset, P, refers to the sensor output, M, for an accelerometer measurement of 0 g. Scale refers to the conversion factor between the sampled unit value and g. The actual scale of any given accelerometer sensor may deviate from these nominal scale values due to, e.g., manufacturing variances. Accordingly the scale factor in the equations above will be proportional to this deviation.

[0038] Accelerometer 506 scale and offset deviations can be measured by, for example, applying 1 g of force along one an axis and measuring the result, R1. Then a -1 g force is applied resulting in measurement R2. The individual axis scale, s, and the individual axis offset, p, can be computed as follows:

$$s=(R1-R2)/2 \tag{2}$$

$$p=(R1+R2)/2 \tag{3}$$

In this simple case, P is the column vector of the p for each axis, and S is the diagonal matrix of the 1/s for each axis.

[0039] However, in addition to scale and offset, readings generated by accelerometer 506 may also suffer from cross-

axes effects. Cross-axes effects include non-aligned axes, e.g., wherein one or more of the sensing axes of the accelerometer 506 as it is mounted in the free space pointing device 400 are not aligned with the corresponding axis in the inertial frame of reference, or mechanical errors associated with the machining of the accelerometer 506 itself, e.g., wherein even though the axes are properly aligned, a purely y-axis acceleration force may result in a sensor reading along the z-axis of the accelerometer 506. Both of these effects can also be measured and added to the calibration performed by function 606.

[0040] The accelerometer 506 serves several purposes in exemplary free space pointing devices according to exemplary embodiments of the present invention. For example, if rotational sensors 502 and 504 are implemented using the exemplary Coriolis effect rotational sensors described above, then the output of the rotational sensors 502 and 504 will vary based on the linear acceleration experienced by each rotational sensor. Thus, one exemplary use of the accelerometer 506 is to compensate for fluctuations in the readings generated by the rotational sensors 502 and 504 which are caused by variances in linear acceleration. This can be accomplished by multiplying the converted accelerometer readings by a gain matrix 610 and subtracting (or adding) the results from (or to) the corresponding sampled rotational sensor data 612. For example, the sampled rotational data  $\alpha_y$  from rotational sensor 502 can be compensated for linear acceleration at block 614 as:

$$\alpha_y'=\alpha_y-C*A \tag{4}$$

wherein C is the 1x3 row vector of rotational sensor susceptibility to linear acceleration along each axis given in units/g and A is the calibrated linear acceleration. Similarly, linear acceleration compensation for the sampled rotational data  $\alpha_z$  from rotational sensor 504 can be provided at block 614. The gain matrices, C, vary between rotational sensors due to manufacturing differences. C may be computed using the average value for many rotational sensors, or it may be custom computed for each rotational sensor.

[0041] Like the accelerometer data, the sampled rotational data 612 is then converted from a sampled unit value into a value associated with a rate of angular rotation, e.g., radians/s, at function 616. This conversion step can also include calibration provided by function 618 to compensate the sampled rotational data for, e.g., scale and offset. Conversion/calibration for both  $\alpha_y$  and  $\alpha_z$  can be accomplished using, for example, the following equation:

$$\alpha_{rad/s}=(\alpha'-offset(T))*scale+dOffset \tag{5}$$

wherein  $\alpha'$  refers to the value being converted/calibrated, offset(T) refers to an offset value associated with temperature, scale refers to the conversion factor between the sampled unit value and rad/s, and dOffset refers to a dynamic offset value. Equation (5) may be implemented as a matrix equation in which case all variables are vectors except for scale. In matrix equation form, scale corrects for axis misalignment and rotational offset factors. Each of these variables is discussed in more detail below.

[0042] The offset values offset(T) and dOffset can be determined in a number of different ways. When the free space pointing device 400 is not being rotated in, for example, the y-axis direction, the sensor 502 should output its offset value. However, the offset can be highly affected by

temperature, so this offset value will likely vary. Offset temperature calibration may be performed at the factory, in which case the value(s) for offset(T) can be preprogrammed into the handheld device 400 or, alternatively, offset temperature calibration may also be learned dynamically during the lifetime of the device. To accomplish dynamic offset compensation, an input from a temperature sensor 619 is used in rotation calibration function 618 to compute the current value for offset(T). The offset(T) parameter removes the majority of offset bias from the sensor readings. However, negating nearly all cursor drift at zero movement can be useful for producing a high-performance pointing device. Therefore, the additional factor dOffset, can be computed dynamically while the free space pointing device 400 is in use. The stationary detection function 608 determines when the handheld is most likely stationary and when the offset should be recomputed. Exemplary techniques for implementing stationary detection function 608, as well as other uses therefore, are described below.

[0043] An exemplary implementation of dOffset computation employs calibrated sensor outputs which are low-pass filtered. The stationary output detection function 608 provides an indication to rotation calibration function 618 to trigger computation of, for example, the mean of the low-pass filter output. The stationary output detection function 608 can also control when the newly computed mean is factored into the existing value for dOffset. Those skilled in the art will recognize that a multitude of different techniques can be used for computing the new value for dOffset from the existing value of dOffset and the new mean including, but not limited to, simple averaging, low-pass filtering and Kalman filtering. Additionally, those skilled in the art will recognize that numerous variations for offset compensation of the rotational sensors 502 and 504 can be employed. For example, the offset(T) function can have a constant value (e.g., invariant with temperature), more than two offset compensation values can be used and/or only a single offset value can be computed/used for offset compensation.

[0044] After conversion/calibration at block 616, the inputs from the rotational sensors 502 and 504 can be further processed to rotate those inputs into an inertial frame of reference, i.e., to compensate for tilt associated with the manner in which the user is holding the free space pointing device 400, at function 620. Tilt correction is another significant aspect of some exemplary embodiments of the present invention as it is intended to compensate for differences in usage patterns of free space pointing devices according to the present invention. More specifically, tilt correction according to exemplary embodiments of the present invention is intended to compensate for the fact that users will hold pointing devices in their hands at different x-axis rotational positions, but that the sensing axes of the rotational sensors 502 and 504 in the free space pointing devices 400 are fixed. It is desirable that cursor translation across display 408 is substantially insensitive to the way in which the user grips the free space pointing device 400, e.g., rotating the free space pointing device 400 back and forth in a manner generally corresponding to the horizontal dimension ( $x_2$ -axis) of the display 508 should result in cursor translation along the  $x_2$ -axis, while rotating the free space pointing device up and down in a manner generally corresponding to the vertical dimension ( $y_2$ -axis) of the display 508 should result in cursor translation along the  $y_2$ -axis,

regardless of the orientation in which the user is holding the free space pointing device 400.

[0045] To better understand the need for tilt compensation according to exemplary embodiments of the present invention, consider the example shown in FIG. 6(a). Therein, the user is holding free space pointing device 400 in an exemplary inertial frame of reference, which can be defined as having an x-axis rotational value of 0 degrees, e.g., the inertial frame of reference can that in which the free space device has its bottom substantially parallel to a floor of a room in which, e.g., a television is located. The inertial frame of reference can, purely as an example, correspond to the orientation illustrated in FIG. 6(a) or it can be defined as any other orientation. Rotation of the free space pointing device 400 in either the y-axis or z-axis directions will be sensed by rotational sensors 502 and 504, respectively. For example, rotation of the free space pointing device 400 around the z-axis by an amount  $\Delta z$  as shown in FIG. 6(b) will result in a corresponding cursor translation  $\Delta x_2$  in the  $x_2$  axis dimension across the display 408 (i.e., the distance between the dotted version of cursor 410 and the undotted version).

[0046] If, on the other hand, the user holds the free space pointing device 400 in a different orientation, e.g., with some amount of x-axis rotation relative to the inertial frame of reference, then the information provided by the sensors 502 and 504 would not (absent tilt compensation) provide an accurate representation of the user's intended interface actions. For example, referring to FIG. 6(c), consider a situation wherein the user holds the free space pointing device 400 with an x-axis rotation of 45 degrees relative to the exemplary inertial frame of reference as illustrated in FIG. 6(a). Assuming the same z-axis rotation  $\Delta z$  is imparted to the free space pointing device 400 by a user as in the example of FIG. 6(b), the cursor 410 will instead be translated in both the  $x_2$ -axis direction and the  $y_2$ -axis direction as shown in FIG. 6(d). This is due to the fact that the sensing axis of rotational sensor 502 is now oriented between the y-axis and the z-axis (because of the orientation of the device in the user's hand). Similarly, the sensing axis of the rotational sensor 504 is also oriented between the y-axis and the z-axis (although in a different quadrant). In order to provide an interface which is transparent to the user in terms of how the free space pointing device 400 is held, tilt compensation according to exemplary embodiments of the present invention translates the readings output from rotational sensors 502 and 504 back into the inertial frame of reference as part of processing the readings from these sensors into information indicative of rotational motion of the free space pointing device 400.

[0047] According to exemplary embodiments of the present invention, returning to FIG. 5, this can be accomplished by determining the tilt of the free space pointing device 400 using the inputs y and z received from accelerometer 506 at function 622. More specifically, after the acceleration data is converted and calibrated as described above, it can be low pass filtered at LPF 624 to provide an average acceleration (gravity) value to the tilt determination function 622. Then, tilt  $\theta$  can be calculated in function 622 as:



$$\theta = \tan^{-1}\left(\frac{y}{z}\right) \quad (7)$$

The value  $\theta$  can be numerically computed as  $\text{atan2}(y,z)$  to prevent division by zero and give the correct sign. Then, function **620** can perform the rotation  $R$  of the converted/calibrated inputs  $\alpha y$  and  $\alpha z$  using the equation:

$$R = \begin{bmatrix} \cos\theta\sin\theta \\ -\sin\theta\cos\theta \end{bmatrix} \cdot \begin{bmatrix} \alpha y \\ \alpha z \end{bmatrix} \quad (8)$$

to rotate the converted/calibrated inputs  $\alpha y$  and  $\alpha z$  to compensate for the tilt  $\theta$ . Tilt compensation as described in this exemplary embodiment is a subset of a more general technique for translating sensor readings from the body frame of reference into a user's frame of reference according to another exemplary embodiment of the present invention which is described below.

[0048] Once the calibrated sensor readings have been compensated for linear acceleration, processed into readings indicative of angular rotation of the free space pointing device **400**, and compensated for tilt, post-processing can be performed at blocks **626** and **628**. Exemplary post-processing can include compensation for various factors such as human tremor. Although tremor may be removed using several different methods, one way to remove tremor is by using hysteresis. The angular velocity produced by rotation function **620** is integrated to produce an angular position. Hysteresis of a calibrated magnitude is then applied to the angular position. The derivative is taken of the output of the hysteresis block to again yield an angular velocity. The resulting output is then scaled at function **628** (e.g., based on the sampling period) and used to generate a result within the interface, e.g., movement of a cursor **410** on a display **408**.

[0049] Having provided a process description of exemplary free space pointing devices according to the present invention, **FIG. 7** illustrates an exemplary hardware architecture. Therein, a processor **800** communicates with other elements of the free space pointing device including a scroll wheel **802**, JTAG **804**, LEDs **806**, switch matrix **808**, IR photodetector **810**, rotational sensors **812**, accelerometer **814** and transceiver **816**. The scroll wheel **802** is an optional input component which enables a user to provide input to the interface by rotating the scroll wheel **802** clockwise or counterclockwise. JTAG **804** provides the programming and debugging interface to the processor. LEDs **806** provide visual feedback to a user, for example, when a button is pressed. Switch matrix **808** receives inputs, e.g., indications that a button on the free space pointing device **400** has been depressed or released, that are then passed on to processor **800**. The optional IR photodetector **810** can be provided to enable the exemplary free space pointing device to learn IR codes from other remote controls. Rotational sensors **812** provide readings to processor **800** regarding, e.g., the y-axis and z-axis rotation of the free space pointing device as described above. Accelerometer **814** provides readings to processor **800** regarding the linear acceleration of the free space pointing device **400** which can be used as described

above, e.g., to perform tilt compensation and to compensate for errors which linear acceleration introduces into the rotational readings generated by rotational sensors **812**. Transceiver **816** is used to communicate information to and from free space pointing device **400**, e.g., to the system controller **228** or to a processor associated with a computer. The transceiver **816** can be a wireless transceiver, e.g., operating in accordance with the Bluetooth standards for short-range wireless communication or an infrared transceiver. Alternatively, free space pointing device **400** can communicate with systems via a wireline connection.

[0050] In the exemplary embodiment of **FIG. 4**, the free space pointing device **400** includes two rotational sensors **502** and **504**, as well as an accelerometer **506**. However, according to another exemplary embodiment of the present invention, a free space pointing device can alternatively include just one rotational sensor, e.g., for measuring angular velocity in the z-axis direction, and an accelerometer. For such an exemplary embodiment, similar functionality to that described above can be provided by using the accelerometer to determine the angular velocity along the axis which is not sensed by the rotational sensor. For example, rotational velocity around the y-axis can be computed using data generated by the accelerometer and calculating:

$$\omega_y = \frac{\partial \theta_y}{\partial t} = \frac{\partial}{\partial t} \tan^{-1}\left(\frac{x}{z}\right) \quad (9)$$

In addition, the parasitic acceleration effects that are not measured by a rotational sensor should also be removed. These effects include actual linear acceleration, acceleration measured due to rotational velocity and rotational acceleration, and acceleration due to human tremor.

[0051] Stationary detection function **608**, mentioned briefly above, can operate to determine whether the free space pointing device **400** is, for example, either stationary or active (moving). This categorization can be performed in a number of different ways. One way, according to an exemplary embodiment of the present invention, is to compute the variance of the sampled input data of all inputs ( $x$ ,  $y$ ,  $z$ ,  $\alpha y$ ,  $\alpha z$ ) over a predetermined window, e.g., every quarter of a second. This variance is then compared with a threshold to classify the free space pointing device as either stationary or active.

[0052] Another stationary detection technique according to exemplary embodiments of the present invention involves transforming the inputs into the frequency domain by, e.g., performing a Fast Fourier Transform (FFT) on the input data. Then, the data can be analyzed using, e.g., peak detection methods, to determine if the free space pointing device **400** is either stationary or active. Additionally, a third category can be distinguished, specifically the case where a user is holding the free space pointing device **400** but is not moving it (also referred to herein as the "stable" state. This third category can be distinguished from stationary (not held) and active by detecting the small movement of the free space pointing device **400** introduced by a user's hand tremor when the free space pointing device **400** is being held by a user. Peak detection can also be used by stationary detection function **608** to make this determination. Peaks within the range of human tremor frequencies, e.g., nomi-

nally 8-12 Hz, will typically exceed the noise floor of the device (experienced when the device is stationary and not held) by approximately 20 dB.

[0053] In the foregoing examples, the variances in the frequency domain were sensed within a particular frequency range, however the actual frequency range to be monitored and used to characterize the status of the free space pointing device 400 may vary. For example, the nominal tremor frequency range may shift based on e.g., the ergonomics and weight of the free space pointing device 400, e.g., from 8-12 Hz to 4-7 Hz.

[0054] According to another exemplary embodiment of the present invention, stationary detection mechanism 608 can include a state machine. An exemplary state machine is shown in FIG. 8. Therein, the ACTIVE state is, in this example, the default state during which the free space pointing device 400 is moving and being used to, e.g., provide inputs to a user interface. The free space pointing device 400 can enter the ACTIVE state on power-up of the device as indicated by the reset input. If the free space pointing device 400 stops moving, it may then enter the INACTIVE state. The various state transitions illustrated in FIG. 8 can be triggered by any of a number of different criteria including, but not limited to, data output from one or both of the rotational sensors 502 and 504, data output from the accelerometer 506, time domain data, frequency domain data or any combination thereof. State transition conditions will be generically referred to herein using the convention "Condition<sub>stateA→stateB</sub>". For example, the free space pointing device 400 will transition from the ACTIVE state to the INACTIVE state when condition<sub>active→inactive</sub> occurs. For the sole purpose of illustration, consider that condition<sub>active→inactive</sub> can, in an exemplary free space pointing device 400, occur when mean and/or standard deviation values from both the rotational sensor(s) and the accelerometer fall below first predetermined threshold values for a first predetermined time period. When in the ACTIVE state, data received from the motion sensors (e.g., rotational sensor(s) and/or accelerometer) can be separated into first data associated with intentional movement introduced by a user and second data associated with unintentional movement introduced by a user (tremor) using one or more processing techniques such as linear filtering, Kalman filtering, Kalman smoothing, state-space estimation, Expectation-Maximization, or other model-based techniques. The first data can then be further processed to generate an output associated with the intended movement of the handheld device (e.g., to support cursor movement) while the second data can be used as tremor input for, e.g., user identification, as described in more detail in the above-incorporated by reference patent application.

[0055] State transitions can be determined by a number of different conditions based upon the interpreted sensor outputs. Exemplary condition metrics include the variance of the interpreted signals over a time window, the threshold between a reference value and the interpreted signal over a time window, the threshold between a reference value and the filtered interpreted signal over a time window, and the threshold between a reference value and the interpreted signal from a start time can be used to determine state transitions. All, or any combination, of these condition metrics can be used to trigger state transitions. Alternatively, other metrics can also be used. According to one exemplary

embodiment of the present invention, a transition from the INACTIVE state to the ACTIVE state occurs either when (1) a mean value of sensor output(s) over a time window is greater than predetermined threshold(s) or (2) a variance of values of sensor output(s) over a time window is greater than predetermined threshold(s) or (3) an instantaneous delta between sensor values is greater than a predetermined threshold.

[0056] The INACTIVE state enables the stationary detection mechanism 608 to distinguish between brief pauses during which the free space pointing device 400 is still being used, e.g., on the order of a tenth of a second, and an actual transition to either a stable or stationary condition. This protects against the functions which are performed during the STABLE and STATIONARY states, described below, from inadvertently being performed when the free space pointing device is being used. The free space pointing device 400 will transition back to the ACTIVE state when condition<sub>inactive→active</sub> occurs, e.g., if the free space pointing device 400 starts moving again such that the measured outputs from the rotational sensor(s) and the accelerometer exceeds the first threshold before a second predetermined time period in the INACTIVE state elapses.

[0057] The free space pointing device 400 will transition to either the STABLE state or the STATIONARY state after the second predetermined time period elapses. As mentioned earlier, the STABLE state reflects the characterization of the free space pointing device 400 as being held by a person but being substantially unmoving, while the STATIONARY state reflects a characterization of the free space pointing device as not being held by a person. Thus, an exemplary state machine according to the present invention can provide for a transition to the STABLE state after the second predetermined time period has elapsed if minimal movement associated with hand tremor is present or, otherwise, transition to the STATIONARY state.

[0058] The STABLE and STATIONARY states define times during which the free space pointing device 400 can perform various functions. For example, since the STABLE state is intended to reflect times when the user is holding the free space pointing device 400 but is not moving it, the device can record the movement of the free space pointing device 400 when it is in the STABLE state e.g., by storing outputs from the rotational sensor(s) and/or the accelerometer while in this state. These stored measurements can be used to determine a tremor pattern associated with a particular user or users as described below. Likewise, when in the STATIONARY state, the free space pointing device 400 can take readings from the rotational sensors and/or the accelerometer for use in compensating for offset as described above.

[0059] If the free space pointing device 400 starts to move while in either the STABLE or STATIONARY state, this can trigger a return to the ACTIVE state. Otherwise, after measurements are taken, the device can transition to the SLEEP state. While in the sleep state, the device can enter a power down mode wherein power consumption of the free space pointing device is reduced and, e.g., the sampling rate of the rotational sensors and/or the accelerometer is also reduced. The SLEEP state can also be entered via an external command so that the user or another device can command the free space pointing device 400 to enter the SLEEP state.

[0060] Upon receipt of another command, or if the free space pointing device 400 begins to move, the device can transition from the SLEEP state to the WAKEUP state. Like the INACTIVE state, the WAKEUP state provides an opportunity for the device to confirm that a transition to the ACTIVE state is justified, e.g., that the free space pointing device 400 was not inadvertently jostled.

[0061] The conditions for state transitions may be symmetrical or may differ. Thus, the threshold associated with the condition<sub>active\_inactive</sub> may be the same as (or different from) the threshold(s) associated with the condition<sub>inactive\_active</sub>. This enables free space pointing devices according to the present invention to more accurately capture user input. For example, exemplary embodiments which include a state machine implementation allow, among other things, for the threshold for transition into a stationary condition to be different than the threshold for the transition out of a stationary condition.

[0062] Entering or leaving a state can be used to trigger other device functions as well. For example, the user interface can be powered up based on a transition from any state to the ACTIVE state. Conversely, the free space pointing device and/or the user interface can be turned off (or enter a sleep mode) when the free space pointing device transitions from ACTIVE or STABLE to STATIONARY or INACTIVE. Alternatively, the cursor 410 can be displayed or removed from the screen based on the transition from or to the stationary state of the free space pointing device 400.

[0063] According to exemplary embodiments of the present invention, techniques for processing sensed motion remove undesirable effects due to, for example, other user-device interactions, such as button actuation, and/or tremor. Generally, as referred to in FIG. 9, the input to the system is human movement of the handheld, free space pointing device. This movement is sensed by the device (block 910) and processed into representative motion, e.g., at block 912, detailed examples of which are described above. It should be noted, however that these exemplary embodiments of the present invention are not limited to application in the exemplary handheld, free space pointing device 400 described above and are expressly intended to include other handheld devices, e.g., free space pointing devices using other types of motion sensors. The representative motion is then converted into a meaningful representation (block 914) that is processed by exemplary "human factors" techniques according to exemplary embodiments of the present invention at block 916. In the exemplary embodiment described herein, the output of human factors processing 916 is then mapped into, for example, 2D pointer movement. The processed movement is then output by the handheld device, an example of which is data that can be used to control on-screen pointer movement.

[0064] This exemplary embodiment of the present invention includes a variety of different techniques for processing movement during user initiated events including button clicks. According to a first exemplary embodiment, both a distance threshold and a time threshold are employed to process movement information generated by the motion sensor(s), e.g., rotational sensor(s), accelerometer(s), magnetometer(s), gyroscope(s), camera(s), or any combination thereof, etc., after a user action, e.g., a button click, has occurred. Distance alone may not be sufficient to yield both

a stable and a responsive pointer during a button click. When a button press is detected by the hand held device, the output pointer movement from 916 is suppressed until either the distance exceeds a distance threshold or the amount of elapsed time exceeds a time threshold. Either or both of the distance and time thresholds may be different for, e.g., a button press action and button release action. The exemplary button processing may optionally be disabled by sending a command to the handheld. In this context, distance refers to physical device movement distance, an angle moved as detected by the sensor(s), and/or the distance the pointer moves (processed former data).

[0065] Different buttons can also have different thresholds from one another. The amount of movement that the handheld experiences during a button click depends upon a number of factors including, but not limited to, the user, the button actuation force, the button travel, and the location of the button relative to the handheld center of support (normally a user's hand). The button movement processing parameters may be set individually to optimize the performance for each button. In addition, the parameters can be learned based upon the session history or based upon the user if the user is known to the system.

[0066] Additionally, the human factors processing function 916 may store and track the past movement history of the handheld device. For example, when the handheld device detects that a button has been pressed, a processing unit in the handheld device can back up to the time before the user initiated the button event. Physically actuating the button takes a non-finite, measurable amount of time that can be determined by psychological testing and dynamic device measurement. When the button is actuated, the device can revert to the state before the button actuation occurred by deleting data samples taken from the motion sensor(s) during/after the button actuation occurred. Therefore, the errant movement that occurred during the button press will be ignored and "erased". For example, in response to a detected button press, the output from block 916 may change from a detected position P1 (subsequent to a button press action) to a recalled position P2, which position P2 had previously been output by block 916 a predetermined time period prior to the button press action detection. If the device is already processing one button action and is still suppressing movement when another button action occurs, it may be unnecessary for the human factors processing function 916 to reiterate the backing up process.

[0067] In user interfaces, at least two typical types of button activations can occur. In the first type (fine mode clicking) shown in FIG. 10, the user intends precise actuation over a small target and carefully aligns the device, stops movement, and then presses the button. In the second type (coarse mode clicking), the target is large and the user anticipates the next action, i.e., the user may only slow down the pointer without stopping or hovering over the target and may instead intend to click on the target "on-the-fly". For fine mode clicking, the above-described processing technique operates to accurately remove unintentional motion data from the combined data output stream from the motion sensor(s) in the handheld device. However, for the second type of movement, further enhancements may be useful to improve performance.

[0068] To address the additional challenges posed by coarse mode clicking, human factors processing unit 916

may employ a second alternative or complementary technique. According to this second exemplary embodiment, movement data received from the motion sensor(s) is processed into a movement vector and it is assumed that the user may intend some movement change of the cursor or other associated output from the device during the button actuation. As known from Newton's first law, "an object in motion tends to stay in motion". Thus, when a button is pressed on the handheld device, it creates a high-frequency movement that deviates from the path. Using the motion vector and filtered movement information, the output from the pointing device can continue during and after the user-initiated event in a manner which is consistent with previous movement history. This can be accomplished by adding a filter to the processing chain. The filter is designed to permit intended motion during and after the user-initiated event while excluding the high frequency movement associated with the event itself. Many processing methods such as low-pass filtering enable the removal of high-frequency components but at the expense of increased latency. Since latency (the time between the movement of the device and the time the pointer moves) may be important to the user, exemplary embodiments of the present invention can use an adaptive filter which is switched into the signal processing path when a user-initiated event is detected (e.g., based on the same signal which is used by the handheld device to convey the user-event to a user interface). The adaptive filter is configured as a low-pass filter that attenuates sharp, high-frequency button presses. An additional input to the adaptive filtering block is an optional pre-button activity warning that occurs before the button has been completely debounced. The pre-button activity warning reduces the filter latency requirements by allowing the processing to be notified of a button event sooner than it would otherwise. The adaptive filter with the pre-button activity warning minimizes the engineering tradeoff between intended movement and latency.

[0069] According to yet another exemplary embodiment of the present invention, since the designers of free space pointing devices usually know the direction of the undesirable movement at design time, the direction of movement perturbation is therefore known based upon the ergonomics and intended use of the device. For example, the designer knows the direction of button actuation relative to the device. The primary movement consists of either linear movement parallel to the button travel vector or rotational movement due to the torque about the users grip. This knowledge permits the implementation of a directional preference filter that includes the knowledge of the button actuation movement. For example, the filter design can include state-space filters such as a Kalman filter and adaptive filters. Such a filter detects the undesired deviation from the intended path in a known direction during button actuation and then interpolates the desired movement path during button actuation. This preferential filtering yields a more responsive pointer during intended changes in direction while still removing the unintended button movement. One skilled in the art will recognize that the state-space filter can be extended to learn the design parameters during the course of normal use.

[0070] The human factors processing function 916 according to exemplary embodiments of the present invention may implement one or both of the above-described techniques and, if both are used, provide a classifier to switch between

the techniques. For example, when the first, precise type of button click is detected, the first technique can be used. When the second, less precise type of button click is detected, the second technique can be used. One classifier for switching between techniques can use the velocity of the handheld device at the time of button actuation or at the time just before button actuation. For example, if (a) the velocity of the handheld device is below a predetermined velocity threshold then the first technique is employed which discards motion data generated subsequent to a detected event until either motion sensed by the motion sensor(s) indicates that the handheld device has moved more than a predetermined distance threshold or a predetermined time has expired, otherwise, (b) if the velocity of the handheld device is above the predetermined velocity, then the second technique is employed which instead filters the motion data generated subsequent to a detected event.

[0071] Button clicks or presses as referred to in the foregoing exemplary embodiments include, but are not limited to, both button presses and button releases. All of the above techniques can be applied to any known device interaction that yields undesirable movement, and are not limited to button clicks. For example, the above techniques can be applied to scroll wheel actuation, touch pad usage, or capacitive strip usage. Thus, exemplary embodiments of the present invention describe methods and devices for canceling unwanted movement that occurs based upon activating or deactivating another event.

[0072] The parameters for the methods describe above can be adapted to support the expected movement characteristic for the event. In the exemplary embodiment, the parameters for button presses can be different from the parameters for button releases. In addition to movement cancellation, the user interface may impose or suggest additional constraints on user-event handling according to the present invention. For example, in Microsoft Windows™ operating systems, if the cursor moves while the button is pressed, then a "drag" action is initiated. Therefore, parameters associated with motion data processing in response to a button press action by a user can have values which tend to restrict pointer movement during button actuation in order to prevent unwanted drag events. In contrast, cursor movement after a button release in Microsoft Windows™ operating systems has little effect on objects in the user interface and, therefore, exemplary motion data processing in accordance with the present invention can employ parameters (e.g., time and or distance thresholds, filter coefficients, etc.) which tend to be less restrictive of pointer movements as compared to the corresponding parameters associated with motion data processing subsequent to button presses.

[0073] The movement may be processed in the velocity or position domain in a number of different fashions to help remove unwanted button movement. Simple filtering in the velocity domain may be used. The filter may be an FIR or IIR filter, although these may introduce an undesirable amount of processing delay. An adaptive filter can be used successfully without introducing too much delay.

[0074] Exemplary embodiments of the present invention can also be implemented as a Kalman filter (or extended Kalman filter). The Kalman filter could select the most likely usage scenario (stationary or moving) and apply the appropriate movement. Neural networks can be used for the same

result. Thus it will be appreciated that the present invention further provides a method for (a) detecting that an event has occurred, (b) inferring the user's intended motion and (c) interpreting the user's intended motion rather than the actual motion of the handheld device. The motion can be in either the 6DOF free space domain or the mapped 2DOF pointing domain. The 6DOF free-space domain could be in either the device's body frame of reference or the user's frame of reference.

[0075] According to another exemplary embodiment of the present invention, the movement associated with the user-initiated event can be modeled and included explicitly in a motion equation which provides an output from the handheld device based on the motion data gathered from the motion sensor(s). More specifically, using the button press example of a user-initiated event, the movement caused by button presses can be modeled a priori to determine one or more exemplary movement amplitudes and directions associated with the button press action and these values can then be stored in a memory unit of the handheld device. Then, when a button press is detected, the processing unit of the handheld device can use the modeled movement in the motion equation to adapt the output such that it reflects the user's intended motion rather than the movement detected by the motion sensor(s) that was associated with the button press. The processing unit can use the modeled values in a variety of different ways, e.g., subtract them from the detected motion values, attenuate the detected motion values based on the modeled values associated with the particular user-initiated event, adjust a semantic map associated with the handheld's output, etc.

[0076] Any or all of the parameters described above for the exemplary embodiment can be modified under control of the user interface. The user interface or an application may know a priori that the user intends fine movement and can instruct the exemplary embodiment to process all events as if fine movement mode was enabled. In addition the amount of subtraction, attenuation, or filtering may be adjusted under control of the user interface or application.

[0077] Systems and methods for processing data according to exemplary embodiments of the present invention can be performed by one or more processors executing sequences of instructions contained in a memory device. Such instructions may be read into the memory device from other computer-readable mediums such as secondary data storage device(s). Execution of the sequences of instructions contained in the memory device causes the processor to operate, for example, as described above. In alternative embodiments, hard-wire circuitry may be used in place of or in combination with software instructions to implement the present invention.

[0078] The above-described exemplary embodiments are intended to be illustrative in all respects, rather than restrictive, of the present invention. Thus the present invention is capable of many variations in detailed implementation that can be derived from the description contained herein by a person skilled in the art. For example, although the foregoing exemplary embodiments describe, among other things, the use of inertial sensors to detect movement of a device, other types of sensors (e.g., ultrasound, magnetic or optical) can be used instead of, or in addition to, inertial sensors in conjunction with the afore-described signal processing. All

such variations and modifications are considered to be within the scope and spirit of the present invention as defined by the following claims. No element, act, or instruction used in the description of the present application should be construed as critical or essential to the invention unless explicitly described as such. Also, as used herein, the article "a" is intended to include one or more items.

What is claimed is:

1. A handheld, pointing device comprising:

a first rotational sensor for determining rotation of said pointing device about a first axis and generating a first rotational output associated therewith;

a second rotational sensor for determining rotation of said pointing device about a second axis and generating a second rotational output associated therewith;

an accelerometer for determining an acceleration of said pointing device and outputting an acceleration output associated therewith; and

a processing unit for receiving said first and second rotational outputs and said acceleration output and for:

(a) detecting a user-initiated event;

(b) determining a velocity of said handheld pointing device based upon at least one of said first and second rotational outputs and said acceleration output;

(c) if said velocity of said handheld device is below a predetermined velocity threshold, then discarding or attenuating data generated by said first rotational sensor, said second rotational sensor and said accelerometer until either said handheld device has moved more than a predetermined distance or a predetermined time has expired; and

(d) otherwise, if said velocity of said handheld pointing device is above said predetermined velocity threshold, then filtering said data generated by said first rotational sensor, said second rotational sensor and said accelerometer to remove unintended motion associated with said user-initiated event.

2. The handheld, pointing device of claim 1, wherein said user-initiated event is one of: a button press, a button release, scroll wheel actuation, touch pad usage, and capacitive strip usage.

3. A method for operating a free space pointing device comprising the steps of:

sensing movement of the free space pointing device and generating an output associated therewith;

detecting occurrence of an event; and

filtering said output based on said detected event.

4. The method of claim 3, wherein said free space pointing device includes at least one button and said event is a button press or button release action.

5. The method of claim 3, wherein said step of filtering further comprises the step of:

filtering said output using a first filter if said event is of a first type and using a second filter if said event is of a second type.

6. The method of claim 5, wherein said first type of said event is a button press and said second type of said event is a button release.

7. The method of claim 3, wherein said step of sensing movement of the free space pointing device and generating an output associated therewith further comprises:

using at least one of an accelerometer, a rotational sensor, a gyroscope, a magnetometer, an optical sensor and a camera to sense said movement.

8. The method of claim 3, wherein said step of filtering said output based on said detected event further comprises the step of:

permitting some data generated by at least one sensor to be processed immediately subsequent to said detected event.

9. A method for operating a free space pointing device comprising the steps of:

sensing movement of the free space pointing device and generating an output associated therewith;

detecting occurrence of an event; and

discarding or attenuating said output until a predetermined time has elapsed after said detection of said event.

10. The method of claim 9, wherein said free space pointing device includes at least one button and said event is a button press or button release action.

11. The method of claim 9, wherein said step of sensing movement of the free space pointing device and generating an output associated therewith further comprises:

using at least one of an accelerometer, a rotational sensor, a gyroscope, a magnetometer, an optical sensor and a camera to sense said movement.

12. A method for operating a free space pointing device comprising the steps of:

sensing movement of the free space pointing device and generating an output associated therewith;

detecting occurrence of an event; and

discarding or attenuating said output until either a predetermined time has elapsed after said detection of said event or said free space pointing device has moved a predetermined distance after said detection of said event, whichever comes first.

13. The method of claim 12, wherein said free space pointing device includes at least one button and said event is a button press or button release action.

14. The method of claim 12, wherein said step of sensing movement of the free space pointing device and generating an output associated therewith further comprises:

using at least one of an accelerometer, a rotational sensor, a gyroscope, a magnetometer, an optical sensor and a camera to sense said movement.

15. A method for operating a free space pointing device comprising the steps of:

(a) sensing movement of the free space pointing device and generating an output associated therewith;

(b) detecting occurrence of an event;

(c) determining a velocity of said free space pointing device;

(d) if said velocity of said free space pointing device is below a predetermined velocity threshold, then discarding or attenuating movement information sensed after said detected occurrence of said event; and

(e) otherwise, if said velocity of said free space pointing device is above said predetermined velocity threshold, then filtering movement information sensed after said detected occurrence of said event to remove unintended motion associated with said user-initiated event.

16. The method of claim 15, wherein movement information is discarded until either said handheld device has moved more than a predetermined distance or a predetermined time has expired.

17. The method of claim 15, wherein said free space pointing device includes at least one button and said event is a button press or button release action.

18. The method of claim 15, wherein said step of sensing movement of the free space pointing device and generating an output associated therewith further comprises:

using at least one of an accelerometer, a rotational sensor, a gyroscope, a magnetometer, an optical sensor and a camera to sense said movement.

19. A handheld pointing device comprising:

at least one motion sensor for sensing movement of the handheld pointing device and generating an output associated therewith;

a processing unit for detecting occurrence of an event and for filtering said output based on said detected event.

20. The handheld pointing device of claim 19, wherein said handheld pointing device includes at least one button and said event is a button press or button release action.

21. The handheld pointing device of claim 19, wherein said processing unit filters said output using a first filter if said event is of a first type and using a second filter if said event is of a second type.

22. The handheld pointing device of claim 21, wherein said first type of said event is a button press and said second type of said event is a button release.

23. The handheld pointing device of 19, wherein said at least one motion sensor includes at least one of an accelerometer, a rotational sensor, a gyroscope, a magnetometer, an optical sensor and a camera.

24. The handheld pointing device of claim 19, wherein said processing unit filters said output to permit some data generated by at least one sensor to be processed immediately subsequent to said detected event.

25. A handheld pointing device comprising:

at least one motion sensor for sensing movement of the handheld pointing device and generating an output associated therewith; and

a processing unit for detecting occurrence of an event and for discarding or attenuating said output until a predetermined time has elapsed after said detection of said event.

26. The handheld pointing device of claim 25, wherein said handheld pointing device includes at least one button and said event is a button press or button release action.

27. The handheld pointing device of claim 26, wherein said at least one motion sensor includes at least one of an accelerometer, a rotational sensor, a gyroscope, a magnetometer, an optical sensor and a camera.

**28.** A handheld pointing device comprising:

at least one motion sensor for sensing movement of the handheld pointing device and generating an output associated therewith; and

a processing unit for detecting occurrence of an event and discarding or attenuating said output until either a predetermined time has elapsed after said detection of said event or said handheld pointing device has moved a predetermined distance after said detection of said event, whichever comes first.

**29.** The handheld pointing device of claim 28, wherein said handheld pointing device includes at least one button and said event is a button press or button release action.

**30.** The handheld pointing device of claim 28, wherein said at least one motion sensor includes at least one of an accelerometer, a rotational sensor, a gyroscope, a magnetometer, an optical sensor and a camera.

**31.** A handheld pointing device comprising:

at least one motion sensor for sensing movement of the handheld pointing device and generating an output associated therewith; and

a processing unit for detecting occurrence of an event, determining a velocity of said free space pointing device based on said sensed movement, wherein

(a) if said velocity of said free space pointing device is below a predetermined velocity threshold, then said processing unit discards movement information sensed after said detected occurrence of said event; and

(b) otherwise, if said velocity of said free space pointing device is above said predetermined velocity

threshold, then said processing unit filters movement information sensed after said detected occurrence of said event to remove unintended motion associated with said user-initiated event.

**32.** The handheld pointing device of claim 31, wherein said movement information is discarded until either said handheld device has moved more than a predetermined distance or a predetermined time has expired.

**33.** The handheld pointing device of claim 31, wherein said handheld pointing device includes at least one button and said event is a button press or button release action.

**34.** The handheld pointing device of claim 31, wherein said at least one motion sensor includes at least one of an accelerometer, a rotational sensor, a gyroscope, a magnetometer, an optical sensor and a camera.

**35.** A handheld pointing device comprising:

at least one motion sensor for sensing movement of the handheld pointing device and generating an output associated therewith;

a memory unit for storing at least one value associated with an event; and

a processing unit for detecting occurrence of said event and for adjusting said output based on said at least one stored value.

**36.** The handheld pointing device of claim 35, wherein said handheld pointing device includes at least one button and said event is a button press or button release action.

**37.** The handheld pointing device of claim 35, wherein said at least one motion sensor includes at least one of an accelerometer, a rotational sensor, a gyroscope, a magnetometer, an optical sensor and a camera.

\* \* \* \* \*