



US 20210084260A1

(19) **United States**

(12) **Patent Application Publication**
Koravadi et al.

(10) **Pub. No.: US 2021/0084260 A1**

(43) **Pub. Date: Mar. 18, 2021**

(54) **VEHICULAR CONTROL SYSTEM WITH FORWARD VIEWING CAMERA AND FORWARD AND REARWARD SENSING SENSORS**

(71) Applicant: **MAGNA ELECTRONICS INC.**,
Auburn Hills, MI (US)

(72) Inventors: **Krishna Koravadi**, Rochester Hills, MI (US); **Ove J. Salomonsson**, Farmington Hills, MI (US)

(21) Appl. No.: **17/247,079**

(22) Filed: **Nov. 30, 2020**

Related U.S. Application Data

(63) Continuation of application No. 16/571,644, filed on Sep. 16, 2019, now Pat. No. 10,855,953, which is a continuation of application No. 15/189,326, filed on Jun. 22, 2016, now Pat. No. 10,419,723.

(60) Provisional application No. 62/184,546, filed on Jun. 25, 2015.

Publication Classification

(51) **Int. Cl.**
H04N 7/18 (2006.01)
H04B 7/06 (2006.01)
H04W 4/80 (2006.01)
(52) **U.S. Cl.**
CPC *H04N 7/18* (2013.01); *H04N 7/183* (2013.01); *H04W 4/80* (2018.02); *H04B 7/0617* (2013.01)

(57) **ABSTRACT**

A vehicular control system includes a forward sensing sensor, a rearward sensing sensor and a forward viewing camera disposed at a vehicle. The forward and rearward sensing sensors each have an antenna array that emits a beam forward or rearward of the vehicle. An ECU includes an image processor operable to process image data captured by the camera. The ECU, responsive at least in part to processing by the image processor of image data captured by the camera, determines presence of snow and/or a driving condition at the vehicle. The ECU may adjust the beam emitted by the antenna array of the forward sensing sensor and/or the rearward sensing sensor responsive to determination of snow and/or the driving condition at the vehicle. The control may adjust power of the beam and/or a beam pattern of the beam responsive to determination of snow and/or the driving condition at the vehicle.

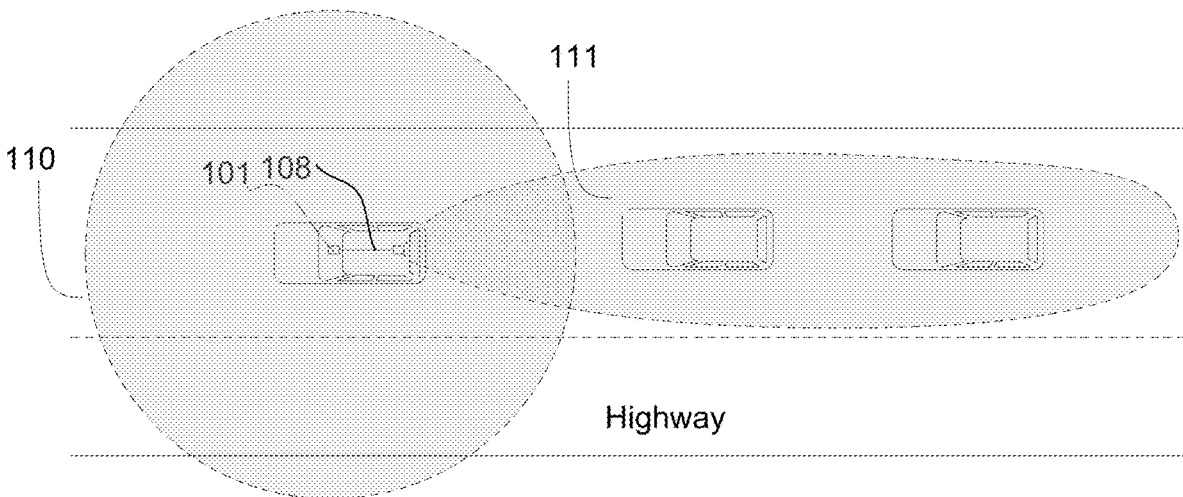

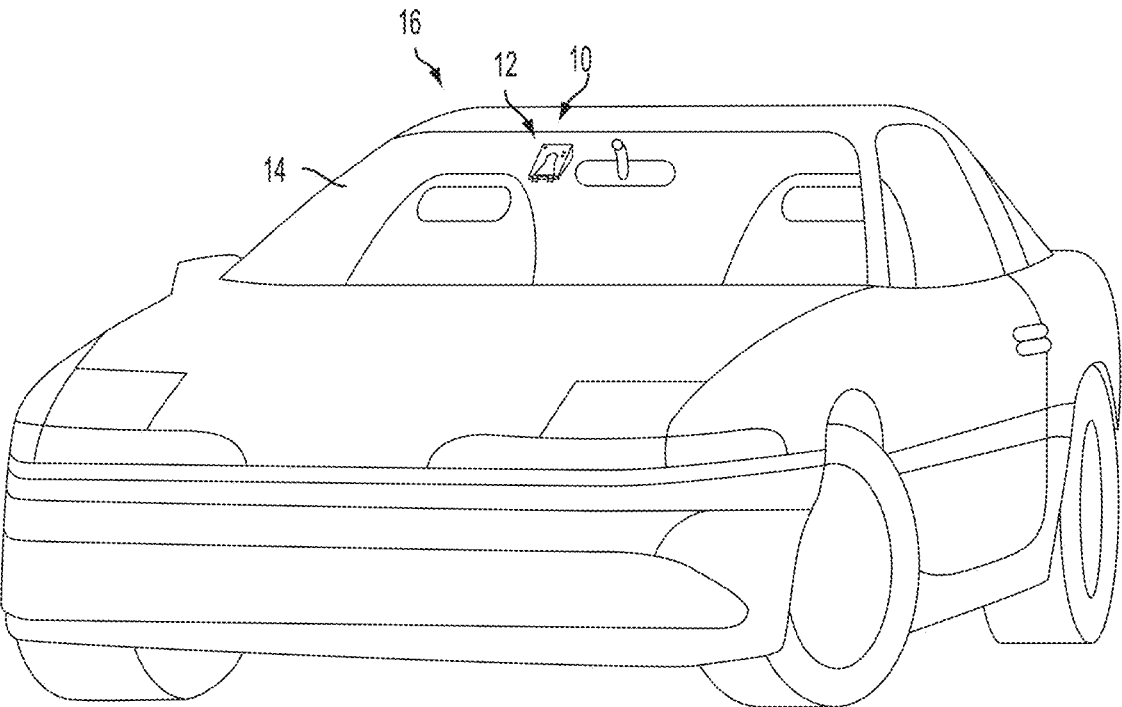

FIG. 1

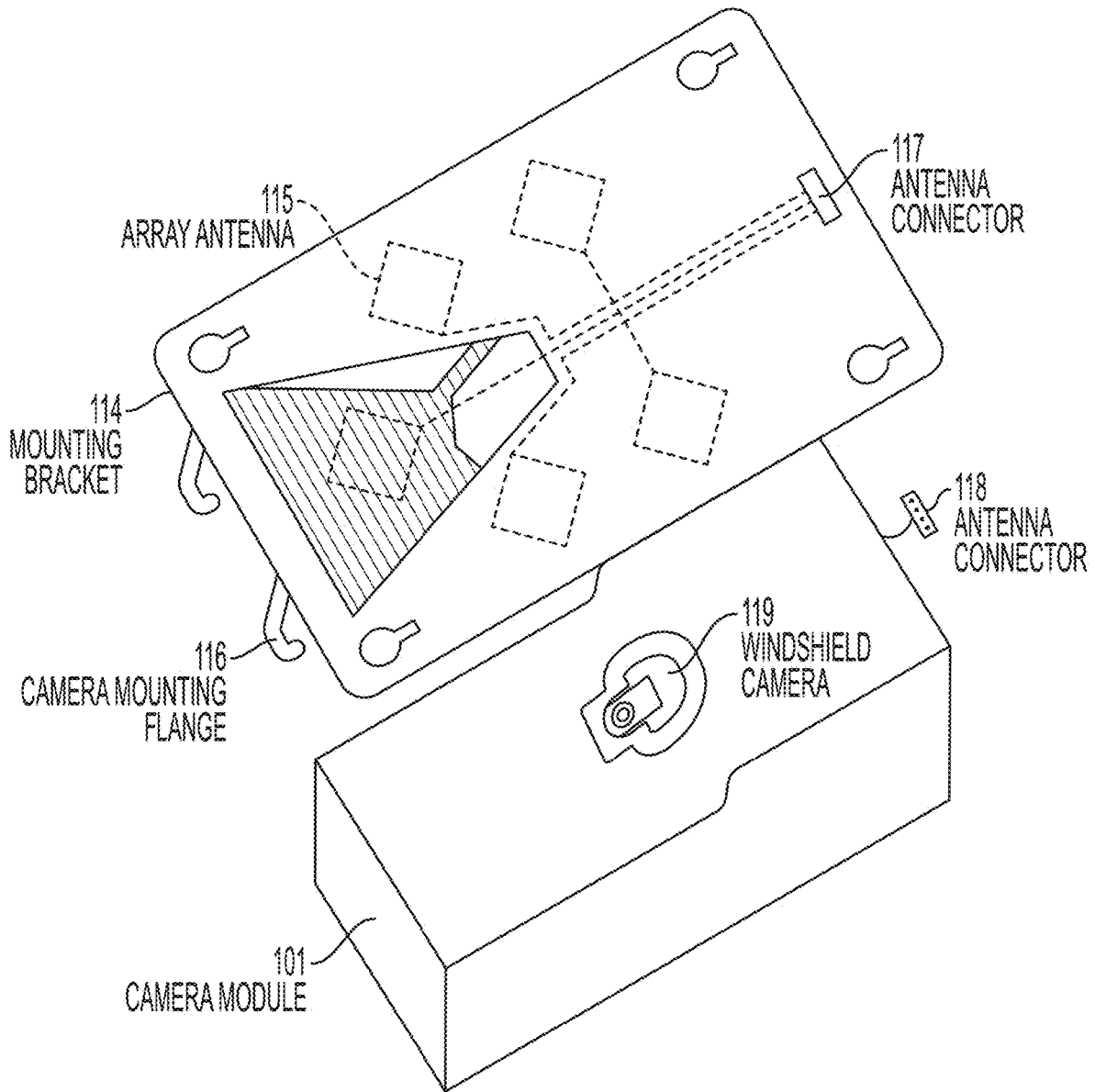

FIG. 2

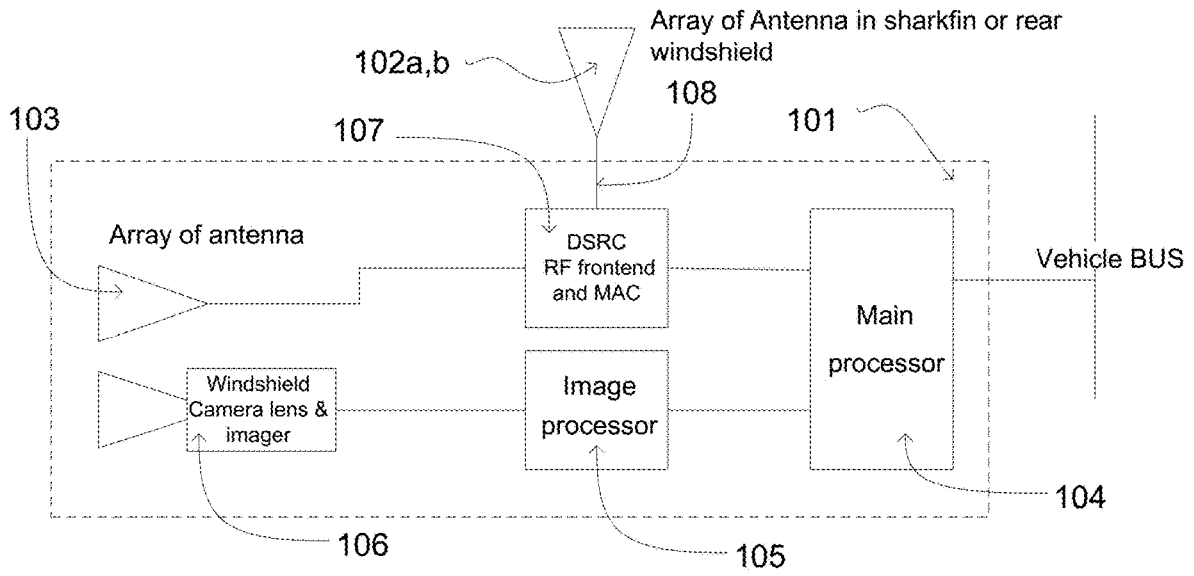

FIG. 3

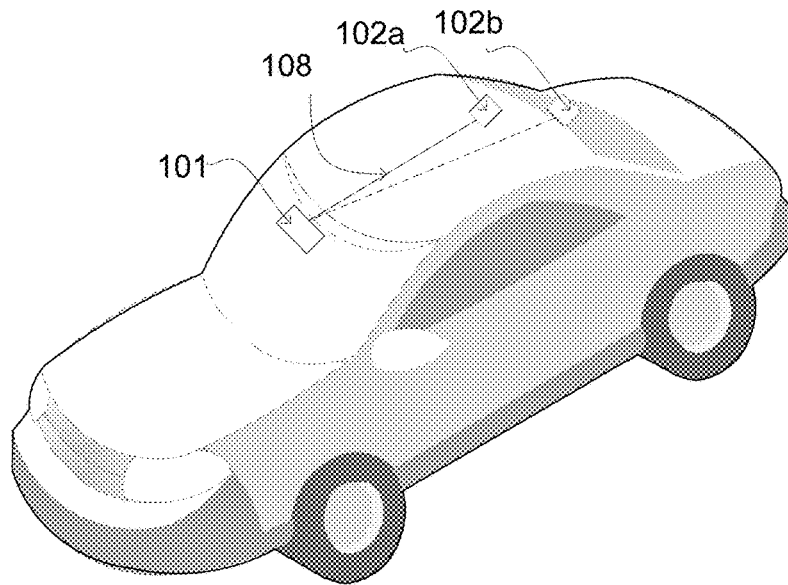

FIG. 4

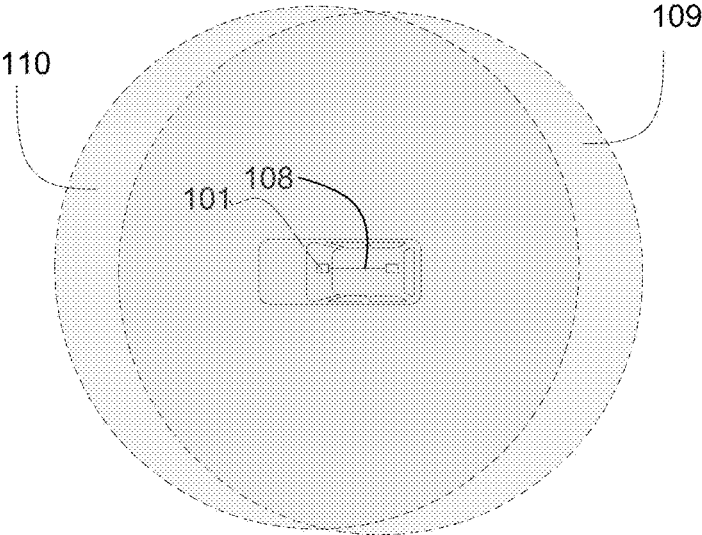

FIG. 5

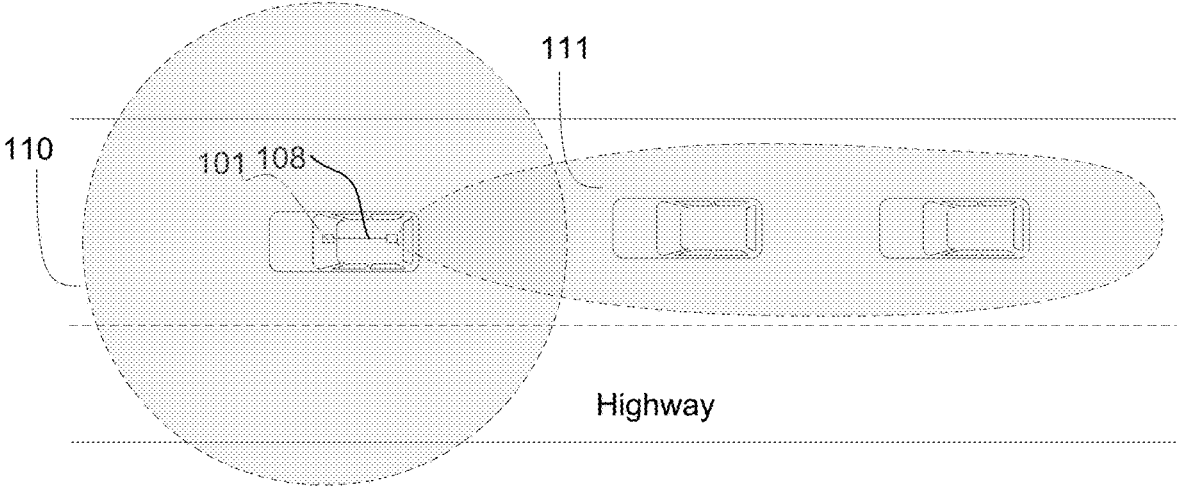

FIG. 6

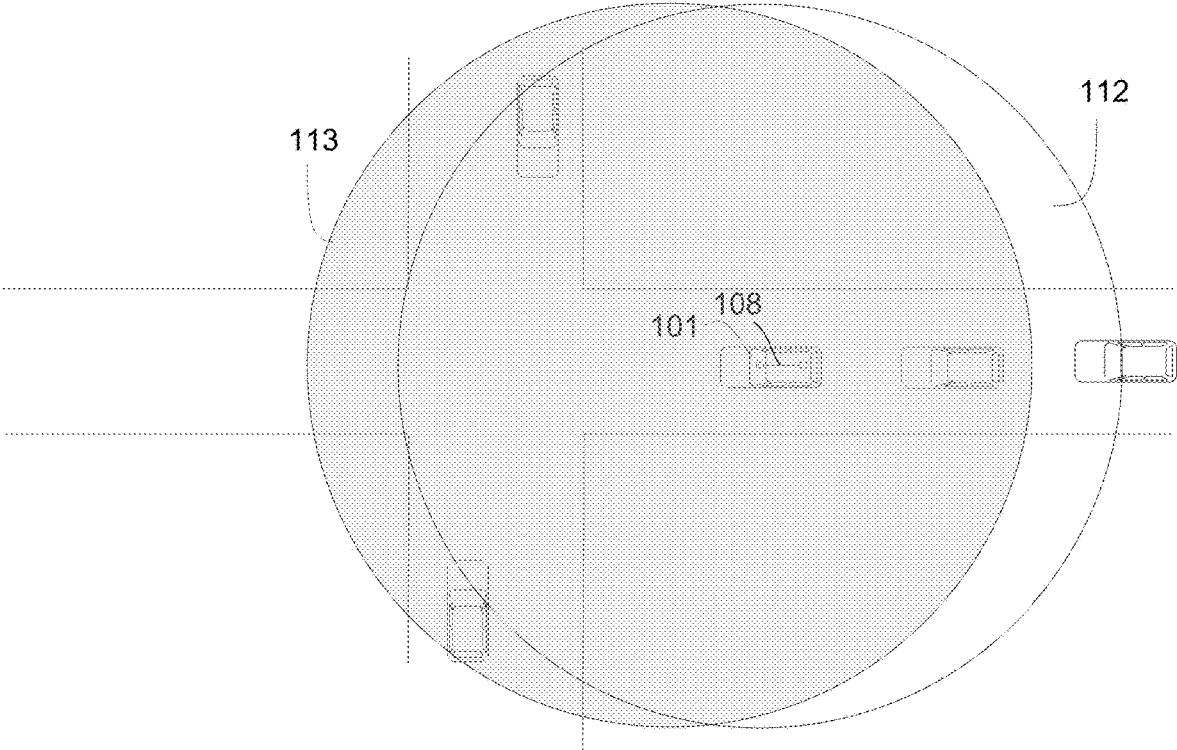

FIG. 7

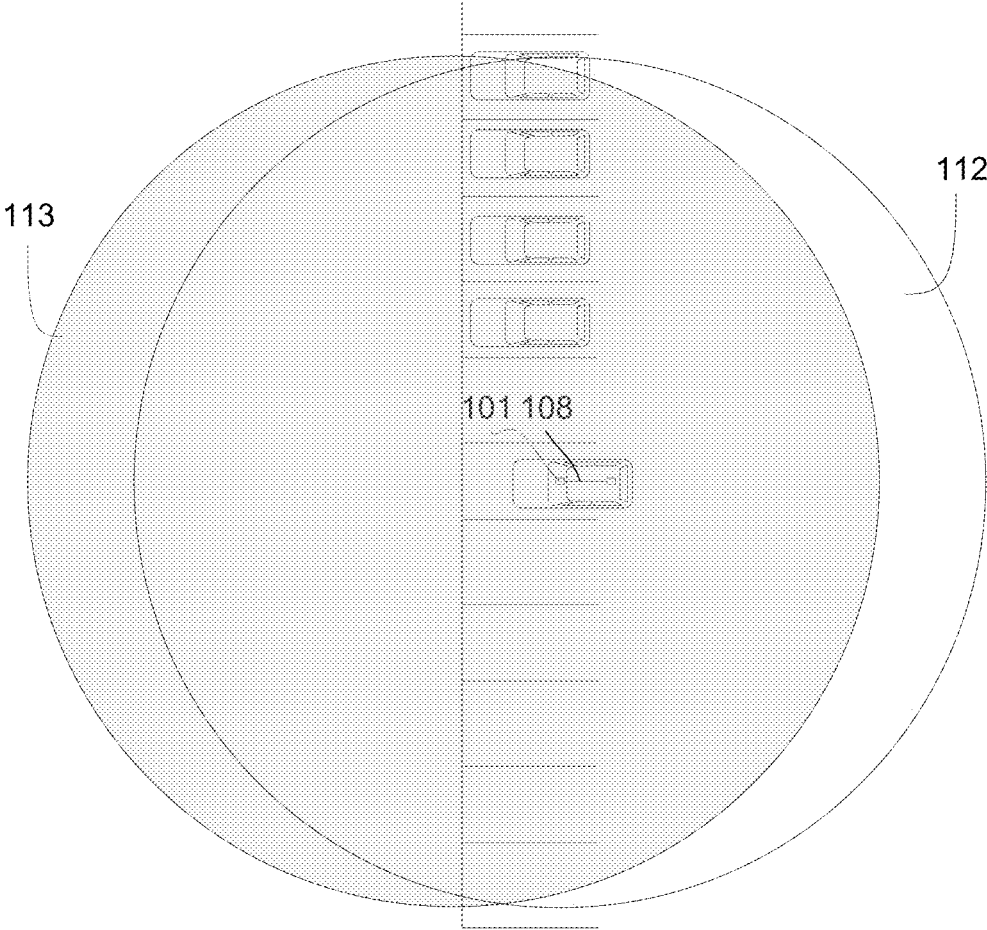

FIG. 8

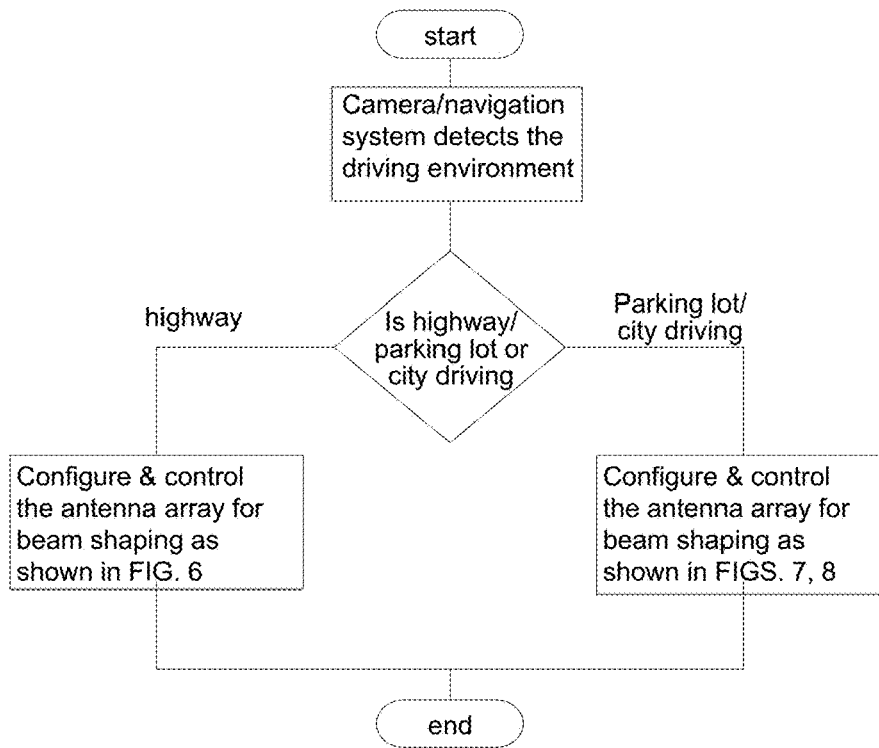

FIG. 9

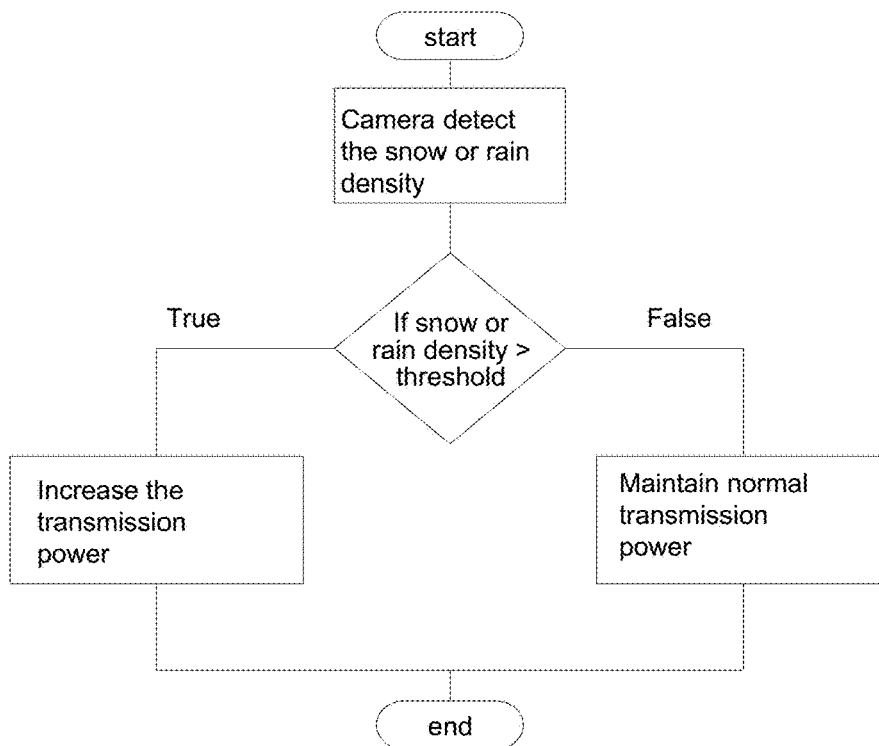

FIG. 10

**VEHICULAR CONTROL SYSTEM WITH
FORWARD VIEWING CAMERA AND
FORWARD AND REARWARD SENSING
SENSORS**

**CROSS REFERENCE TO RELATED
APPLICATIONS**

[0001] The present application is a continuation of U.S. patent application Ser. No. 16/571,644, filed Sep. 16, 2019, now U.S. Pat. No. 10,855,953, which is a continuation of U.S. patent application Ser. No. 15/189,326, filed Jun. 22, 2016, now U.S. Pat. No. 10,419,723, which claims the filing benefits of U.S. provisional application Ser. No. 62/184,546, filed Jun. 25, 2015, which is hereby incorporated herein by reference in its entirety.

FIELD OF THE INVENTION

[0002] The present invention relates generally to a vehicle vision system for a vehicle and, more particularly, to a vehicle vision system that utilizes a forward facing camera, such as at a vehicle windshield.

BACKGROUND OF THE INVENTION

[0003] Use of imaging sensors in vehicle imaging systems is common and known. Examples of such known systems are described in U.S. Pat. Nos. 5,949,331; 5,670,935 and/or 5,550,677, which are hereby incorporated herein by reference in their entireties.

[0004] Dedicated Short Range Communication (DSRC) radio technology has been developed in recent past to enable communications-based active safety systems. The communication link for such applications needs a reliable, high speed, low latency that is immune to extreme weather conditions, works reliably in high speed mobility conditions and multipath roadway environments.

SUMMARY OF THE INVENTION

[0005] The present invention provides a communication system and vision system or imaging system for a vehicle that utilizes one or more cameras (preferably one or more CMOS cameras) to capture image data representative of images exterior of the vehicle, and provides a windshield camera having an integrated DSRC radio with multi diversified array antenna. The present invention comprises a methods and apparatus to enhance the performance of DSRC communication in the vehicle utilizing antenna diversity, dynamic beam pattern control, and dynamic transmission power control methodology utilizing the forward viewing camera.

[0006] In accordance with an aspect of the present invention, a communication system for a vehicle includes an antenna array for transmitting data to at least one other vehicle or structure. A control is operable to adjust a beam transmission of the antenna array responsive to determination of a driving condition of the vehicle. The antenna array may be disposed at a camera of the vehicle, such as at a forward viewing windshield mounted camera of the vehicle. For example, the antenna array may be integrated in a camera mounting bracket at the windshield of the vehicle. Optionally, a second antenna array may be disposed at a rearward portion of the vehicle, such as at a "shark fin" antenna element or a rear camera of the vehicle. The control may be operable to adjust a beam transmission of one of the

antenna arrays independent of the beam transmission of the other of the antenna arrays. For example, the control may adjust the beam transmission of one of the antenna arrays (such as the front array) to an omnidirectional beam and to adjust the beam transmission of the other of the antenna arrays (such as the rear array) to a directional beam so as to provide enhanced transmission range of the other antenna array.

[0007] The control may adjust the beam transmission from an omnidirectional beam to a directed beam to enhance the transmission range of the beam. For example, the control may adjust the beam transmission to the directed beam directed rearward of the vehicle responsive to a determination of a highway driving condition. The control may adjust the beam transmission responsive to a determination of at least one of (i) a highway driving condition, (ii) a high traffic driving condition, (iii) an intersection driving condition and (iv) an adverse weather condition.

[0008] The antenna array is associated with a DSRC radio of the vehicle. The control may adjust a power output of the DSRC radio responsive to a driving condition. For example, the control may adjust the power output of the DSRC radio responsive to a determination of an adverse weather condition.

[0009] These and other objects, advantages, purposes and features of the present invention will become apparent upon review of the following specification in conjunction with the drawings.

BRIEF DESCRIPTION OF THE DRAWINGS

[0010] FIG. 1 is a perspective view of a vehicle with a vision system that incorporates at least a forward viewing camera in accordance with the present invention;

[0011] FIG. 2 is an exploded perspective view of a windshield camera unit with array antennas integrated into the mounting bracket in accordance with the present invention;

[0012] FIG. 3 is a block diagram of windshield camera with a DSRC radio and an integrated antenna array of the present invention;

[0013] FIG. 4 is a layout of windshield camera and shark fin antenna in the vehicle in accordance with the present invention;

[0014] FIG. 5 is a plan view of a vehicle, showing an omnidirectional beam pattern for both the antenna array in the windshield camera and shark fin or rear window;

[0015] FIG. 6 is a plan view of a vehicle, showing an antenna beam pattern for a highway driving scenario where the array antenna in the shark fin/rear window is used as a directional beam directed rearward and the windshield camera array antenna used as omnidirectional pattern in accordance with the present invention;

[0016] FIG. 7 is a plan view of a vehicle, showing an antenna beam pattern for a city driving situation where the vehicle is approaching an intersection and where the array antenna in shark fin/rear window is used as a directional beam directed rearward and the windshield camera array antenna is used as omnidirectional pattern in accordance with the present invention;

[0017] FIG. 8 is a plan view of a vehicle, showing an antenna beam pattern for a parking lot driving situation where the array antenna in the shark fin/rear window and the windshield camera array antenna are used as an omnidirectional pattern in accordance with the present invention;

[0018] FIG. 9 is a flow chart of the dynamic antenna transmission beam control using the camera data in accordance with the present invention; and

[0019] FIG. 10 is a flow chart of the dynamic antenna transmission power control depending on the density of the snow and rain detected by camera and traffic density in accordance with the present invention.

LEGEND

- [0020] **101** Integrated windshield camera unit with array antenna with DSRC radio components
- [0021] **102a** DSRC array antenna in shark fin unit
- [0022] **102b** DSRC array antenna in the rear window
- [0023] **103** DSRC array antenna as an integral part of the windshield camera unit
- [0024] **104** Main processor process the video and V2X data
- [0025] **105** Image processor process the video data
- [0026] **106** Windshield camera lens and imager
- [0027] **107** DSRC RF frontend and MAC (Media Access Control)
- [0028] **108** Antenna cable for the shark fin antenna array or rear windshield antenna array
- [0029] **109** Shark fin/rear windshield antenna array omnidirectional beam pattern
- [0030] **110** Windshield array antenna omnidirectional beam pattern
- [0031] **111** Directional beam pattern of shark fin/rear windshield antenna
- [0032] **112, 113** Omnidirectional beam pattern
- [0033] **114** Windshield camera mounting bracket
- [0034] **115** Mounting bracket integrated with array antennas
- [0035] **116** Camera mounting flange
- [0036] **117** Antenna connector
- [0037] **118** Antenna connector part of windshield camera
- [0038] **119** Windshield camera lens

DESCRIPTION OF THE PREFERRED EMBODIMENTS

[0039] A vehicle vision system and/or driver assist system and/or object detection system and/or alert system operates to capture images exterior of the vehicle and may process the captured image data to detect objects at or near the vehicle and in the predicted path of the vehicle. The vision system includes an image processor or image processing system that is operable to receive image data from one or more cameras and to process the captured image data.

[0040] Referring now to the drawings and the illustrative embodiments depicted therein, a vehicle imaging system or vision system **10** includes at least one exterior facing imaging sensor or camera, such as a forward facing imaging sensor or camera **12** disposed at the windshield **14** of the vehicle **16** and viewing forwardly through the windshield of the vehicle, with the camera having a lens for focusing images at or onto an imaging array or imaging plane or imager of the camera (FIG. 1). The forward viewing camera is disposed at the windshield of the vehicle and views through the windshield and forward of the vehicle, such as for a machine vision system (such as for traffic sign recognition, headlamp control, pedestrian detection, collision avoidance, lane marker detection and/or the like). The vision

system **12** includes a control or electronic control unit (ECU) or processor that is operable to process image data captured by the camera or cameras and may detect objects or the like. The data transfer or signal communication from the camera to the ECU may comprise any suitable data or communication link, such as a vehicle network bus or the like of the equipped vehicle.

[0041] DSRC radio performance is sensitive to the location of the antenna, and utilizing the antenna diversity techniques a high reliable signal reception in multipath environments can be achieved. Mounting the antenna on the roof or front of the vehicle detracts from the appearance of the vehicle. The present invention provides an elegant look while also providing a reliable signal reception.

[0042] The range of the DSRC communication link may be degraded as the snow or rain water density increases. For safety critical applications it is very important to have good range during such bad weather conditions. The range may be improved if the system is aware of such situations and the transmission power of the radio is dynamically controlled during such situations.

[0043] It is important to have better range toward the rear and rearward of the vehicle especially during highway driving, such that the following vehicles will be aware of the accident or environment condition in advance and limit or prevent multi vehicle pileup accidents. Thus, the present invention may dynamically control the antenna beam depending on the driving situation to provide enhanced range for the given transmission power.

[0044] The performance of the DSRC radio may be improved by utilizing multiple antennas installed at various selected diversified locations at the vehicle. A windshield camera **119** is located at the windshield, and one array antenna **115** may be an integral part of the camera mounting bracket **114** (such as shown in FIG. 2) of the camera module **101** and another array antenna may be an integral part of the shark fin antenna unit **102a** or a rear window camera **102b** (such as shown in FIG. 4).

[0045] As the range of the DSRC link may be improved by controlling the antenna beam, during the highway driving as the traffic flow in one direction, a concentrated beam **111** could be formed rearward of the vehicle, such as shown in FIG. 6, utilizing the antenna array to improve the communication link performance (provides longer range with focused beam formation) to mitigate multi vehicle pileup accidents. Highway driving location is detected by the windshield camera and the shark fin/rear window antenna array is controlled in a method to form a beam concentrating rearwards and the windshield antenna array is controlled to form omnidirectional pattern to communicate surrounding vehicles and the vehicles entering the highway. During dense city traffic and intersection conditions, it is better to have an omnidirectional pattern **110** (FIG. 6) or **112, 113** (FIG. 7) to cover larger surroundings, and similar patterns will be better for the parking lot situation as well, such as shown in FIG. 8. Such dynamic beam pattern control provides tailoring of the antenna transmission beam or beams to enhance communication during various driving conditions.

[0046] As the DSRC radio performance degrades such as due to bad weather conditions like snow, rain, fog and/or the like, the system of the present invention may sense the weather condition (such as by utilizing the windshield camera and processing image data captured by the wind-

shield camera) and, responsive to a determination of bad weather conditions that may adversely affect or degrade the radio performance, the transmission power of the DSRC radio may be dynamically adjusted to improve the range during such bad weather conditions, such as shown in the flowchart of FIG. 10. Such dynamic transmission power control provides tailoring of the power of the signal or radio performance to enhance communication during various driving conditions.

[0047] FIG. 2 is an illustration of an array antenna 115 design as an integral part of the front windshield camera mounting bracket 114, and thus utilizes the prime location of the windshield and provides antenna diversity to the communication system. The array antenna 115 is connected to the camera module utilizing the connector 117 and 118.

[0048] FIG. 3 is a block diagram of the windshield camera module with multi antenna DSRC radio integrated modules, comprising a windshield lens module 106 connected to the image processor 105 capable of detecting the objects, weather conditions, and driving environments (such as highway, city road, parking lot and the like). The DSRC physical layer and MAC 107 is interfaced with the main processor 104. The main processor 104 process vehicle to infrastructure (V2X) communication data and video data and also controls the DSRC radio.

[0049] Such vehicle communication systems may provide for communication between vehicles and/or between a vehicle and a remote server. Such car2car or vehicle to vehicle (V2V) and vehicle to infrastructure (car2X or V2X or V2I) technology provides for communication between vehicles and/or infrastructure based on information provided by one or more vehicles and/or information provided by a remote server or the like. The vehicle communication systems may utilize aspects of the systems described in U.S. Pat. Nos. 6,690,268; 6,693,517; 7,156,796 and/or 7,580,795, and/or U.S. Publication Nos. US-2012-0218412, US-2012-0062743, US-2015-0158499; US-2015-0124096 and/or US-2015-0352953, which are all hereby incorporated herein by reference in their entireties.

[0050] The main processor may also interface with other modules of the vehicle via a vehicle communication network or bus. The DSRC radio comprises two array antenna modules 103 and 102 for antenna diversity, with one array antenna located in the camera mounting bracket 114 (such as shown in FIG. 2) and the other array antenna located in the shark fin module 102a or rear window 102b (such as shown in FIG. 4).

[0051] FIG. 5 is an omnidirectional beam pattern from the front windshield antenna and the shark fin/rear window antenna, such as may be used in parking lot situations (FIG. 8) and high density and/or intersection city driving scenarios (FIG. 7).

[0052] FIG. 6 is an illustration of dynamic beam shaping 111 generated utilizing the antenna array 102a/102b, where the rear antenna array has a rearward directed beam 111 and the front antenna array has an omnidirectional beam pattern 101.

[0053] FIG. 9 is an illustration of dynamic beam shaping flowchart that utilizes the camera data or camera data fused with navigation system information from a vehicle data bus to control the beam shaping of the antennas to enhance the range.

[0054] FIG. 10 is an illustration of dynamic transmission power control flowchart that utilizes the camera data or

camera data fused with the weather data available from weather service information, such as from a vehicle data bus, and may control or adjust or change the transmission power of the radios to enhance or increase the range during the determined bad weather conditions.

[0055] Therefore, the present invention provides a control or system that adjusts the beam of an antenna array responsive to detection of a driving condition, such as weather conditions at or surrounding the vehicle, highway driving conditions, intersection driving conditions, high or low traffic conditions, parking conditions and/or the like. The driving condition or conditions may be determined via any suitable means, such as responsive to a communication received from a GPS system of the vehicle or a vehicle to infrastructure (V2X) system or such as responsive to processing by an image processor of image data captured by one or more cameras of the vehicle, such as the windshield-mounted camera or such as one or more other exterior viewing cameras of the vehicle (such as a forward viewing front-mounted camera and/or sideward viewing side-mounted cameras and/or a rearward viewing rear-mounted camera of the vehicle that operate as part of a multi-camera surround view vision system of the vehicle).

[0056] The system may utilize an omnidirectional beam that covers a generally circular area around the vehicle, and when it is desired to extend the beam further in one direction (such as rearward of the vehicle during highway driving conditions), the system adjusts or controls the beam to provide a directed beam (such as a rearward directed beam) that has an enhanced range in the directed direction as compared to the omnidirectional beam. The system of the present invention thus provides dynamic control or shaping of the antenna beam and range and direction responsive to determined driving conditions at or around the vehicle. Optionally, the system or control may control or dynamically adjust the transmission power of the DSRC radio to improve the range during determined driving conditions, such bad weather conditions, when the transmission power may be degraded.

[0057] The camera or sensor may comprise any suitable camera or sensor. Optionally, the camera may comprise a "smart camera" that includes the imaging sensor array and associated circuitry and image processing circuitry and electrical connectors and the like as part of a camera module, such as by utilizing aspects of the vision systems described in International Publication Nos. WO 2013/081984 and/or WO 2013/081985, which are hereby incorporated herein by reference in their entireties.

[0058] The system includes an image processor operable to process image data captured by the camera or cameras, such as for detecting objects or other vehicles or pedestrians or the like in the field of view of one or more of the cameras. For example, the image processor may comprise an EYEQ2 or EYEQ3 image processing chip available from Mobileye Vision Technologies Ltd. of Jerusalem, Israel, and may include object detection software (such as the types described in U.S. Pat. Nos. 7,855,755; 7,720,580 and/or 7,038,577, which are hereby incorporated herein by reference in their entireties), and may analyze image data to detect vehicles and/or other objects. Responsive to such image processing, and when an object or other vehicle is detected, the system may generate an alert to the driver of the vehicle and/or may generate an overlay at the displayed image to highlight or enhance display of the detected object

or vehicle, in order to enhance the driver's awareness of the detected object or vehicle or hazardous condition during a driving maneuver of the equipped vehicle.

[0059] The vehicle may include any type of sensor or sensors, such as imaging sensors or radar sensors or lidar sensors or ladar sensors or ultrasonic sensors or the like. The imaging sensor or camera may capture image data for image processing and may comprise any suitable camera or sensing device, such as, for example, a two dimensional array of a plurality of photosensor elements arranged in at least 640 columns and 480 rows (at least a 640x480 imaging array, such as a megapixel imaging array or the like), with a respective lens focusing images onto respective portions of the array. The photosensor array may comprise a plurality of photosensor elements arranged in a photosensor array having rows and columns. Preferably, the imaging array has at least 300,000 photosensor elements or pixels, more preferably at least 500,000 photosensor elements or pixels and more preferably at least 1 million photosensor elements or pixels. The imaging array may capture color image data, such as via spectral filtering at the array, such as via an RGB (red, green and blue) filter or via a red/red complement filter or such as via an RCC (red, clear, clear) filter or the like. The logic and control circuit of the imaging sensor may function in any known manner, and the image processing and algorithmic processing may comprise any suitable means for processing the images and/or image data.

[0060] The camera module and circuit chip or board and imaging sensor may be implemented and operated in connection with various vehicular vision-based systems, and/or may be operable utilizing the principles of such other vehicular systems, such as a vehicle headlamp control system, such as the type disclosed in U.S. Pat. Nos. 5,796,094; 6,097,023; 6,320,176; 6,559,435; 6,831,261; 7,004,606; 7,339,149 and/or 7,526,103, which are all hereby incorporated herein by reference in their entireties, a rain sensor, such as the types disclosed in commonly assigned U.S. Pat. Nos. 6,353,392; 6,313,454; 6,320,176 and/or 7,480,149, which are hereby incorporated herein by reference in their entireties, a vehicle vision system, such as a forwardly, sidewardly or rearwardly directed vehicle vision system utilizing principles disclosed in U.S. Pat. Nos. 5,550,677; 5,670,935; 5,760,962; 5,877,897; 5,949,331; 6,222,447; 6,302,545; 6,396,397; 6,498,620; 6,523,964; 6,611,202; 6,201,642; 6,690,268; 6,717,610; 6,757,109; 6,802,617; 6,806,452; 6,822,563; 6,891,563; 6,946,978 and/or 7,859,565, which are all hereby incorporated herein by reference in their entireties, a traffic sign recognition system, a system for determining a distance to a leading vehicle or object, such as a system utilizing the principles disclosed in U.S. Pat. Nos. 6,396,397 and/or 7,123,168, which are hereby incorporated herein by reference in their entireties, and/or the like.

[0061] Optionally, the vision system (utilizing the forward facing camera and a rearward facing camera and other cameras disposed at the vehicle with exterior fields of view) may be part of or may provide a display of a top-down view or birds-eye view system of the vehicle or a surround view at the vehicle, such as by utilizing aspects of the vision systems described in International Publication Nos. WO 2010/099416; WO 2011/028686; WO 2012/075250; WO 2013/019795; WO 2012/075250; WO 2012/145822; WO 2013/081985; WO 2013/086249 and/or WO 2013/109869, and/or U.S. Publication No. US-2012-0162427, which are

hereby incorporated herein by reference in their entireties. Optionally, for example, the system may include multiple exterior facing imaging sensors or cameras, such as a forwardly facing camera at the front of the vehicle, and a sidewardly/rearwardly facing camera at respective sides of the vehicle), which capture images exterior of the vehicle. **[0062]** Changes and modifications in the specifically described embodiments can be carried out without departing from the principles of the invention, which is intended to be limited only by the scope of the appended claims, as interpreted according to the principles of patent law including the doctrine of equivalents.

1. A vehicular control system, said vehicular control system comprising:

a forward sensing sensor disposed at a vehicle equipped with said vehicular control system, wherein said forward sensing sensor comprises an antenna array that emits a beam external and at least forward of the equipped vehicle;

a rearward sensing sensor disposed at the equipped vehicle, wherein said rearward sensing sensor comprises an antenna array that emits a beam external and at least rearward of the equipped vehicle;

a forward viewing camera disposed at an in-cabin side of a windshield of the equipped vehicle and viewing forward of the equipped vehicle through the windshield, wherein said forward viewing camera is operable to capture image data;

an electronic control unit (ECU) comprising an image processor operable to process image data captured by said forward viewing camera;

wherein said ECU, responsive at least in part to processing by said image processor of image data captured by said forward viewing camera, determines presence of snow at the equipped vehicle; and

wherein, responsive to determination of snow at the equipped vehicle, said ECU adjusts the beam emitted by the antenna array of at least one selected from the group consisting of said forward sensing sensor and said rearward sensing sensor.

2. The vehicular control system of claim 1, wherein said ECU adjusts a beam pattern of the beam emitted by the antenna array of the at least one selected from the group consisting of said forward sensing sensor and said rearward sensing sensor responsive to determination of presence of snow at the equipped vehicle.

3. The vehicular control system of claim 2, wherein said ECU adjusts the beam pattern of the beam emitted by the antenna array of the at least one selected from the group consisting of said forward sensing sensor and said rearward sensing sensor between an omnidirectional beam and a directed beam.

4. The vehicular control system of claim 2, wherein said ECU adjusts the beam emitted by the antenna array of the at least one selected from the group consisting of said forward sensing sensor and said rearward sensing sensor from an omnidirectional beam to a directed beam to enhance range of the beam emitted by the antenna array.

5. The vehicular control system of claim 2, wherein, responsive to determination of presence of snow at the equipped vehicle, said ECU dynamically adjusts the beam pattern of the beam emitted by the antenna array of the at least one selected from the group consisting of said forward sensing sensor and said rearward sensing sensor to enhance

the beam emitted by the antenna array of the at least one selected from the group consisting of said forward sensing sensor and said rearward sensing sensor.

6. The vehicular control system of claim 1, wherein said ECU adjusts power of the beam emitted by the antenna array of the at least one selected from the group consisting of said forward sensing sensor and said rearward sensing sensor responsive to determination of presence of snow at the equipped vehicle.

7. The vehicular control system of claim 6, wherein, responsive at least in part to determination of presence of snow at the equipped vehicle, said ECU increases power of the beam emitted by the antenna array of the at least one selected from the group consisting of said forward sensing sensor and said rearward sensing sensor to increase range of the beam emitted by the antenna array.

8. The vehicular control system of claim 1, wherein, responsive to determination of presence of snow at the equipped vehicle, said ECU dynamically adjusts power of the beam emitted by the antenna array of the at least one selected from the group consisting of said forward sensing sensor and said rearward sensing sensor to enhance the beam emitted by the antenna array.

9. The vehicular control system of claim 1, wherein said ECU determines presence of snow at the equipped vehicle in part responsive to weather data received from a weather service external of the equipped vehicle.

10. The vehicular control system of claim 1, wherein said ECU adjusts the beam emitted by the antenna array of the at least one selected from the group consisting of said forward sensing sensor and said rearward sensing sensor responsive to a determined driving condition selected from the group consisting of (i) a highway driving condition, (ii) a traffic condition and (iii) an intersection condition.

11. The vehicular control system of claim 10, wherein said ECU adjusts a beam pattern of the beam emitted by the antenna array of said rearward sensing sensor to a rearward directed beam responsive to determination of a highway driving condition.

12. The vehicular control system of claim 10, wherein said ECU adjusts a beam pattern of the beams emitted by the antenna arrays of said forward sensing sensor and said rearward sensing sensor to omnidirectional beams responsive to determination of an intersection condition.

13. The vehicular control system of claim 10, wherein said ECU adjusts a beam pattern of the beams emitted by the antenna arrays of said forward sensing sensor and said rearward sensing sensor to omnidirectional beams responsive to determination of a parking condition.

14. The vehicular control system of claim 1, wherein said ECU is operable to adjust the beam emitted by the antenna array of said forward sensing sensor independent of the beam emitted by the antenna array of said rearward sensing sensor.

15. The vehicular control system of claim 1, wherein, responsive to determination of increasing snow at the equipped vehicle, said ECU increases power of the beam emitted by the antenna array of the at least one selected from the group consisting of said forward sensing sensor and said rearward sensing sensor.

16. A vehicular control system, said vehicular control system comprising:

- a forward sensing sensor disposed at a vehicle equipped with said vehicular control system, wherein said for-

ward sensing sensor comprises an antenna array that emits a beam external and at least forward of the equipped vehicle;

- a rearward sensing sensor disposed at the equipped vehicle, wherein said rearward sensing sensor comprises an antenna array that emits a beam external and at least rearward of the equipped vehicle;

- a forward viewing camera disposed at an in-cabin side of a windshield of the equipped vehicle and viewing forward of the equipped vehicle through the windshield, wherein said forward viewing camera is operable to capture image data;

- an electronic control unit (ECU) comprising an image processor operable to process image data captured by said forward viewing camera;

wherein said ECU is operable to adjust a beam pattern of the beam emitted by the antenna array of at least one selected from the group consisting of said forward sensing sensor and said rearward sensing sensor; and

wherein said ECU adjusts the beam pattern of the beam emitted by the antenna array of the at least one selected from the group consisting of said forward sensing sensor and said rearward sensing sensor responsive to determination, at least in part via processing at said ECU of image data captured by said forward viewing camera, of a driving condition selected from the group consisting of (i) a highway driving condition, (ii) a traffic condition and (iii) an intersection condition.

17. The vehicular control system of claim 16, wherein said ECU is operable to adjust the beam pattern of the beam emitted by the antenna array of the at least one selected from the group consisting of said forward sensing sensor and said rearward sensing sensor between an omnidirectional beam and a directed beam.

18. The vehicular control system of claim 16, wherein said ECU, responsive at least in part to processing by said image processor of image data captured by said forward viewing camera, determines presence of snow at the equipped vehicle, and wherein said ECU adjusts the beam pattern of the beam emitted by the antenna array of the at least one selected from the group consisting of said forward sensing sensor and said rearward sensing sensor responsive to determination of snow at the equipped vehicle.

19. The vehicular control system of claim 18, wherein said ECU determines presence of snow at the equipped vehicle in part responsive to weather data received from a weather service external of the equipped vehicle.

20. The vehicular control system of claim 18, wherein, responsive to determination of presence of snow at the equipped vehicle, said ECU adjusts the beam pattern of the beam emitted by the antenna array of the at least one selected from the group consisting of said forward sensing sensor and said rearward sensing sensor between an omnidirectional beam and a directed beam.

21. The vehicular control system of claim 18, wherein, responsive to determination of presence of snow at the equipped vehicle, said ECU adjusts power of the beam emitted by the antenna array of the at least one selected from the group consisting of said forward sensing sensor and said rearward sensing sensor.

22. The vehicular control system of claim 16, wherein said ECU adjusts the beam pattern of the beam emitted by the antenna array of said rearward sensing sensor from an

omnidirectional beam to a rearward directed beam responsive to determination of a highway driving condition.

23. The vehicular control system of claim **16**, wherein said ECU adjusts the beam pattern of the beams emitted by the antenna arrays of said forward sensing sensor and said rearward sensing sensor to omnidirectional beams responsive to determination of an intersection condition.

24. The vehicular control system of claim **16**, wherein said ECU adjusts the beam pattern of the beams emitted by the antenna arrays of said forward sensing sensor and said rearward sensing sensor to omnidirectional beams responsive to determination of a parking condition.

25. The vehicular control system of claim **16**, wherein said ECU is operable to adjust the beam emitted by the antenna array of said forward sensing sensor independent of the beam emitted by the antenna array of said rearward sensing sensor.

26. A vehicular control system, said vehicular control system comprising:

- a forward sensing sensor disposed at a vehicle equipped with said vehicular control system, wherein said forward sensing sensor comprises an antenna array that emits a beam external and at least forward of the equipped vehicle;

- a forward viewing camera disposed at an in-cabin side of a windshield of the equipped vehicle and viewing forward of the equipped vehicle through the windshield, wherein said forward viewing camera is operable to capture image data;

- an electronic control unit (ECU) comprising an image processor operable to process image data captured by said forward viewing camera;

- wherein said ECU is operable to adjust a beam pattern of the beam emitted by the antenna array of said forward sensing sensor; and

- wherein said ECU adjusts the beam pattern of the beam emitted by the antenna array of said forward sensing sensor responsive to determination, at least in part via processing at said ECU of image data captured by said forward viewing camera, of a driving condition selected from the group consisting of (i) a highway driving condition, (ii) a traffic condition and (iii) an intersection condition.

27. The vehicular control system of claim **26**, wherein said ECU is operable to adjust the beam pattern of the beam emitted by the antenna array of said forward sensing sensor between an omnidirectional beam and a directed beam.

28. The vehicular control system of claim **26**, wherein said ECU, responsive at least in part to processing by said image processor of image data captured by said forward viewing camera, determines presence of snow at the equipped vehicle, and wherein said ECU adjusts the beam pattern of the beam emitted by the antenna array of said forward sensing sensor responsive to determination of snow at the equipped vehicle.

29. The vehicular control system of claim **28**, wherein said ECU determines presence of snow at the equipped vehicle in part responsive to weather data received from a weather service external of the equipped vehicle.

30. The vehicular control system of claim **28**, wherein, responsive to determination of presence of snow at the equipped vehicle, said ECU adjusts the beam pattern of the beam emitted by the antenna array of said forward sensing sensor between an omnidirectional beam and a directed beam.

31. The vehicular control system of claim **28**, wherein, responsive to determination of presence of snow at the equipped vehicle, said ECU adjusts power of the beam emitted by the antenna array of said forward sensing sensor.

32. The vehicular control system of claim **26**, further comprising a rearward sensing sensor disposed at the equipped vehicle, wherein said rearward sensing sensor comprises an antenna array that emits a beam external and at least rearward of the equipped vehicle, and wherein said ECU adjusts the beam pattern of the beam emitted by the antenna array of said rearward sensing sensor from an omnidirectional beam to a rearward directed beam responsive to determination of a highway driving condition.

33. The vehicular control system of claim **32**, wherein said ECU is operable to adjust the beam emitted by the antenna array of said forward sensing sensor independent of adjustment of the beam emitted by the antenna array of said rearward sensing sensor.

34. The vehicular control system of claim **26**, wherein said ECU adjusts the beam pattern of the beam emitted by the antenna array of said forward sensing sensor to an omnidirectional beam responsive to determination of an intersection condition.

35. The vehicular control system of claim **26**, wherein said ECU adjusts the beam pattern of the beam emitted by the antenna array of said forward sensing sensor to an omnidirectional beam responsive to determination of a parking condition.

* * * * *