



US 20180083199A1

(19) **United States**

(12) **Patent Application Publication**
Kawakami et al.

(10) **Pub. No.: US 2018/0083199 A1**

(43) **Pub. Date: Mar. 22, 2018**

(54) **HETEROCYCLIC COMPOUND,
LIGHT-EMITTING ELEMENT,
LIGHT-EMITTING DEVICE, ELECTRONIC
DEVICE, AND LIGHTING DEVICE**

(30) **Foreign Application Priority Data**

Aug. 29, 2013 (JP) 2013-178449

May 2, 2014 (JP) 2014-095259

(71) Applicant: **Semiconductor Energy Laboratory
Co., Ltd.**, Kanagawa-ken (JP)

Publication Classification

(51) **Int. Cl.**
H01L 51/00 (2006.01)
C09K 11/06 (2006.01)

(72) Inventors: **Sachiko Kawakami**, Atsugi (JP);
Hiromi SEO, Sagamihara (JP);
Tatsuyoshi TAKAHASHI, Atsugi (JP);
Satoshi SEO, Sagamihara (JP)

(52) **U.S. Cl.**
CPC **H01L 51/0071** (2013.01); **C09K 2211/145**
(2013.01); **H01L 51/5072** (2013.01); **H01L**
51/0072 (2013.01); **H01L 51/0074** (2013.01);
C09K 11/06 (2013.01)

(73) Assignee: **Semiconductor Energy Laboratory
Co., Ltd.**, Kanagawa-ken (JP)

(57) **ABSTRACT**

(21) Appl. No.: **15/810,725**

A novel heterocyclic compound that can be used as a host material in which a light-emitting substance is dispersed. A light-emitting element having a long lifetime. A heterocyclic compound in which a substituted or unsubstituted dibenzo [f,h]quinoxaliny] group is bonded to a substituted or unsubstituted arylene group having 6 to 25 carbon atoms which is bonded to any one of the 8-11 positions of a substituted or unsubstituted benzo[b]naphtho[1,2-d]furan skeleton.

(22) Filed: **Nov. 13, 2017**

Related U.S. Application Data

(63) Continuation of application No. 14/468,954, filed on Aug. 26, 2014, now Pat. No. 9,825,238.

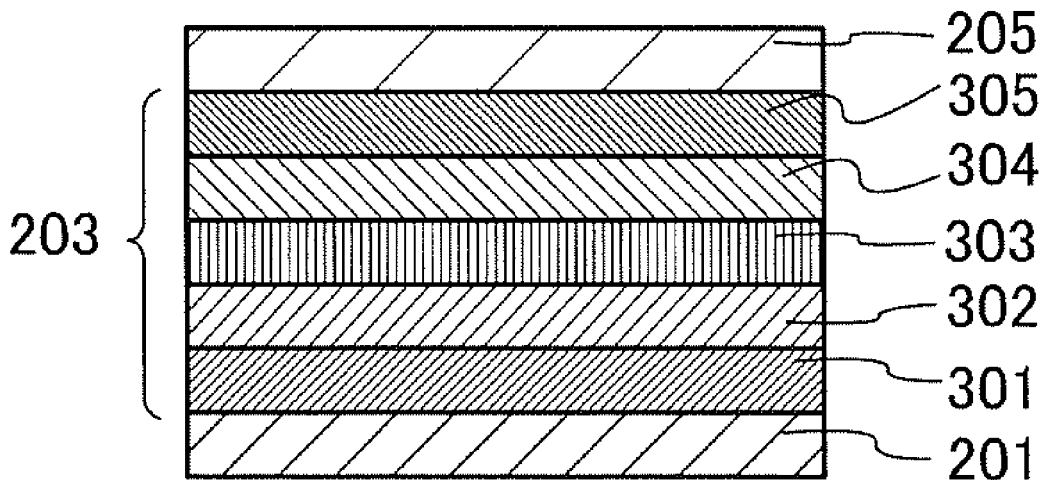

FIG. 1A

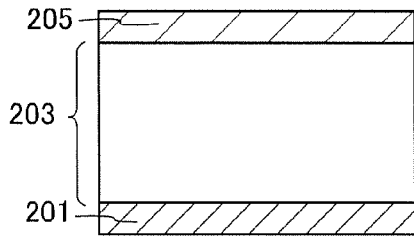

FIG. 1B

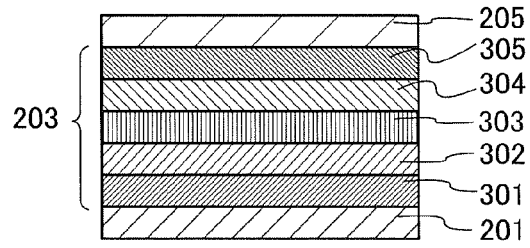

FIG. 1C

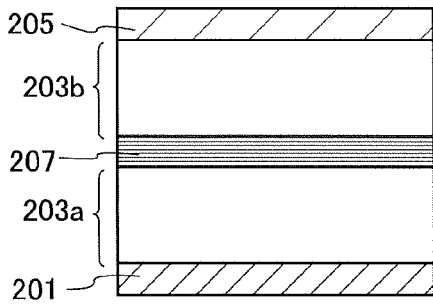
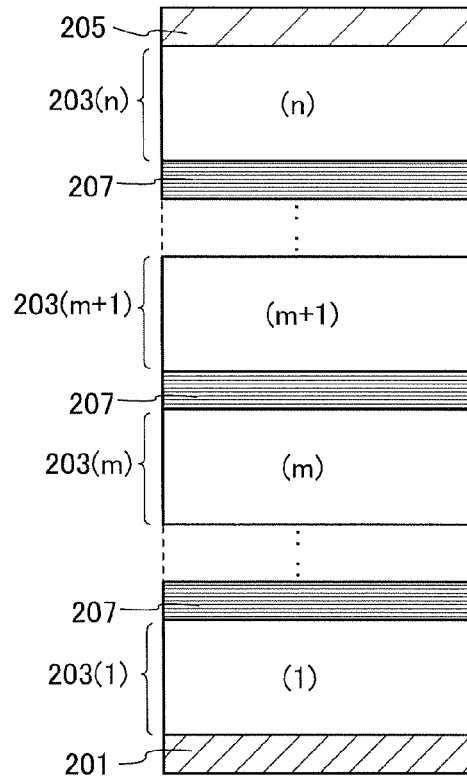
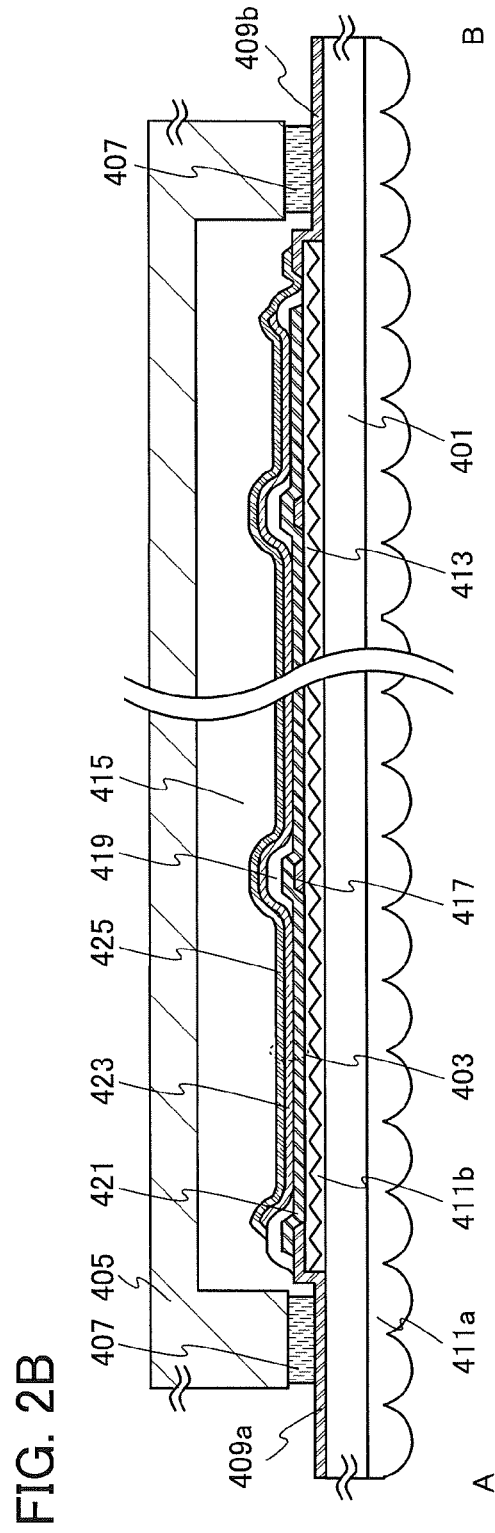
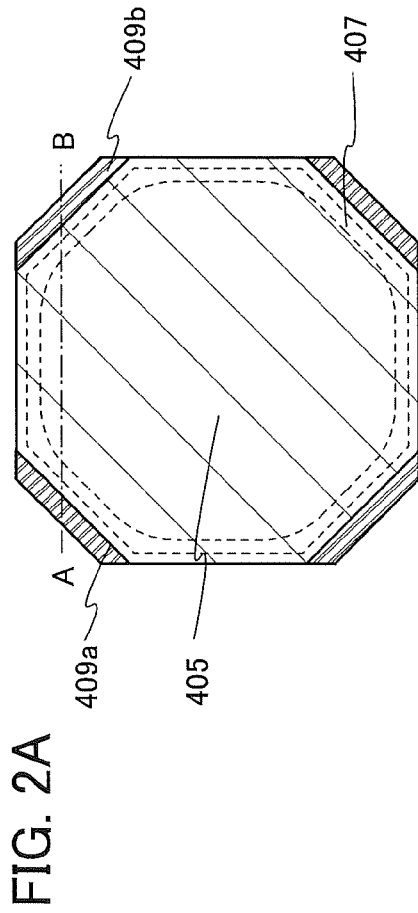

FIG. 1D





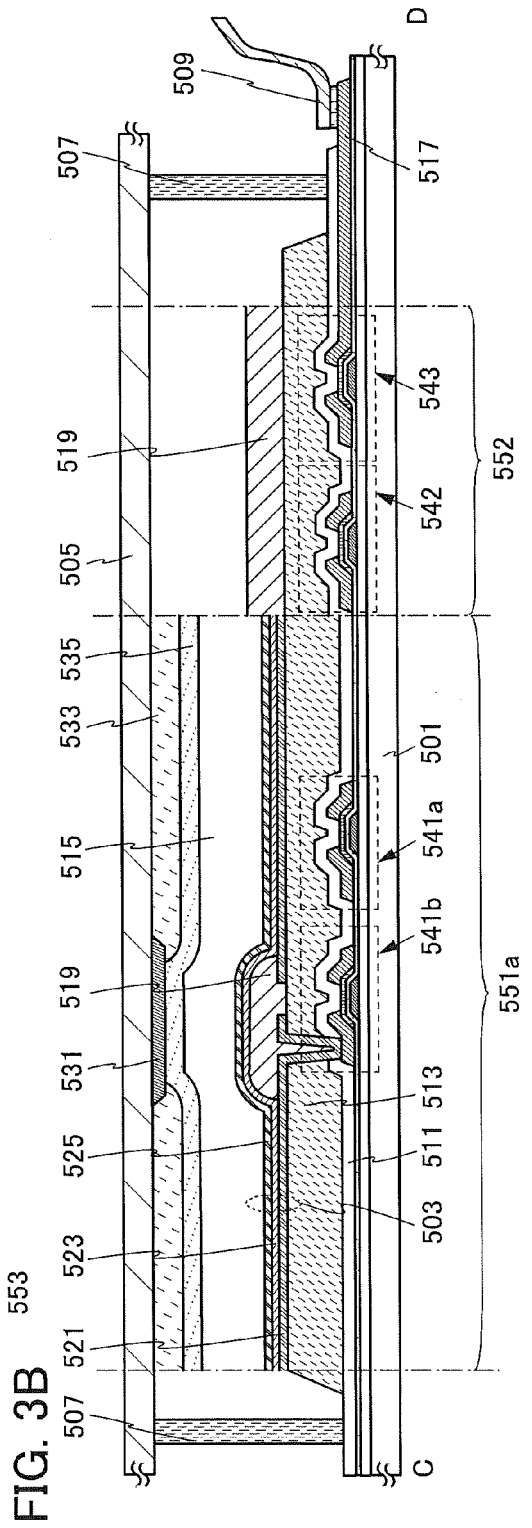
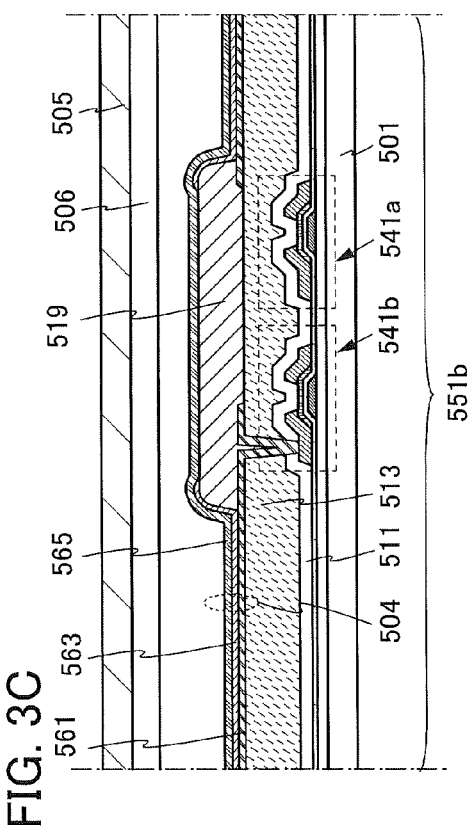
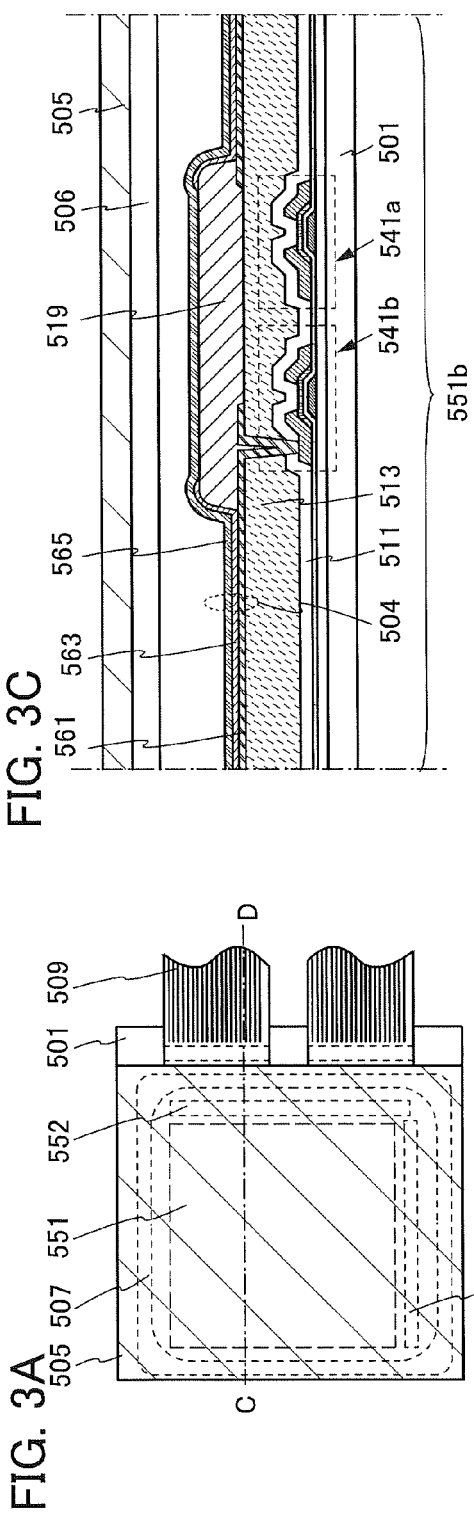

FIG. 4A

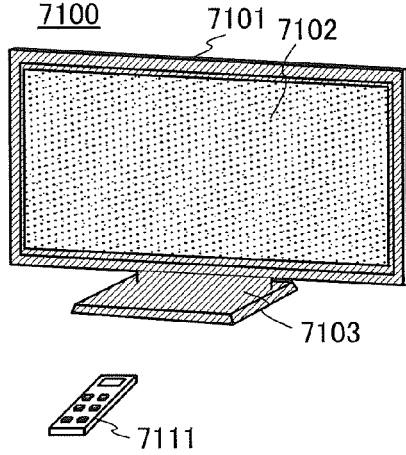

FIG. 4B

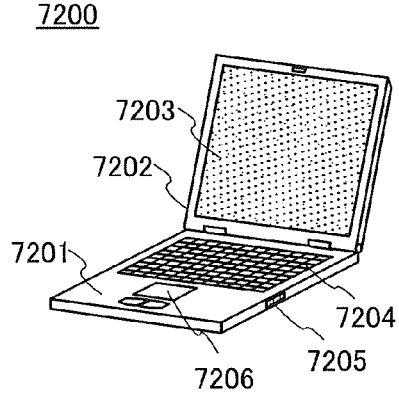

FIG. 4C

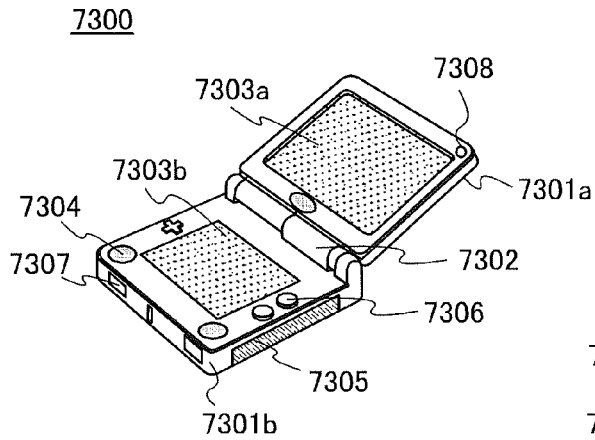

FIG. 4D

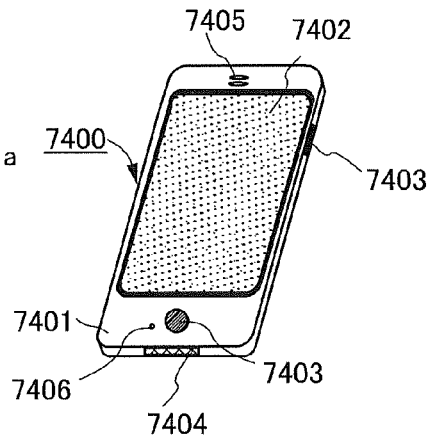

FIG. 4E

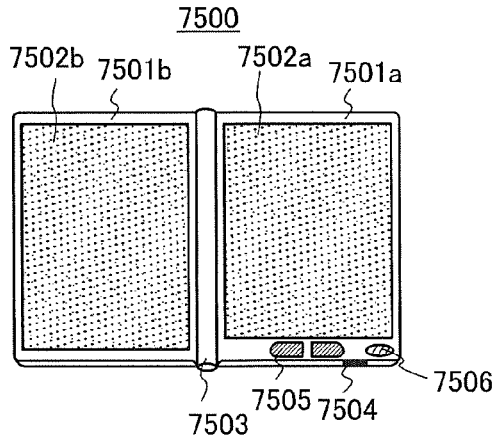

FIG. 5A

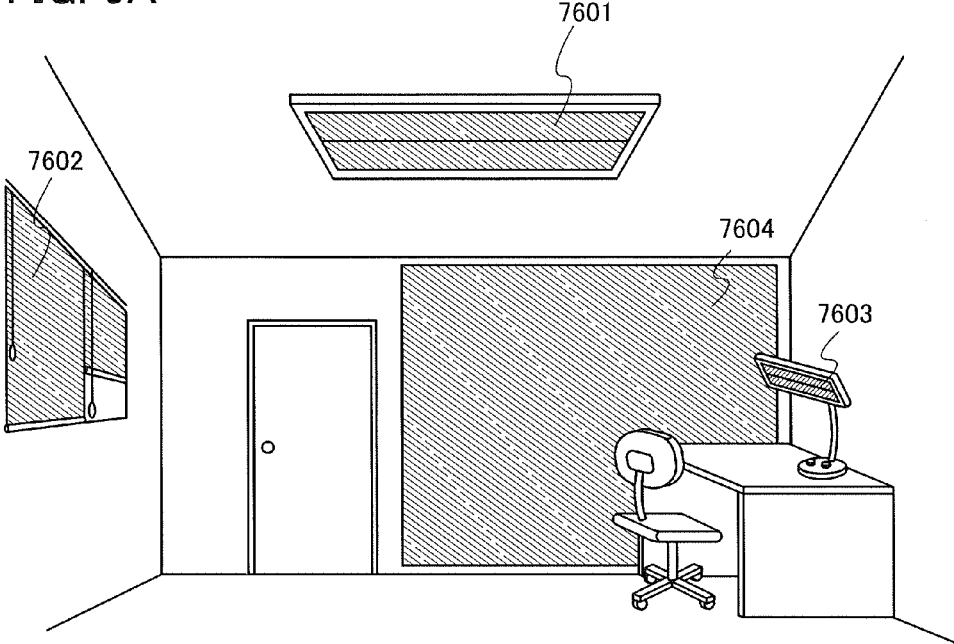

FIG. 5B

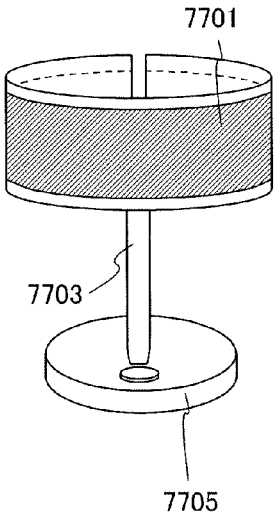

FIG. 6A

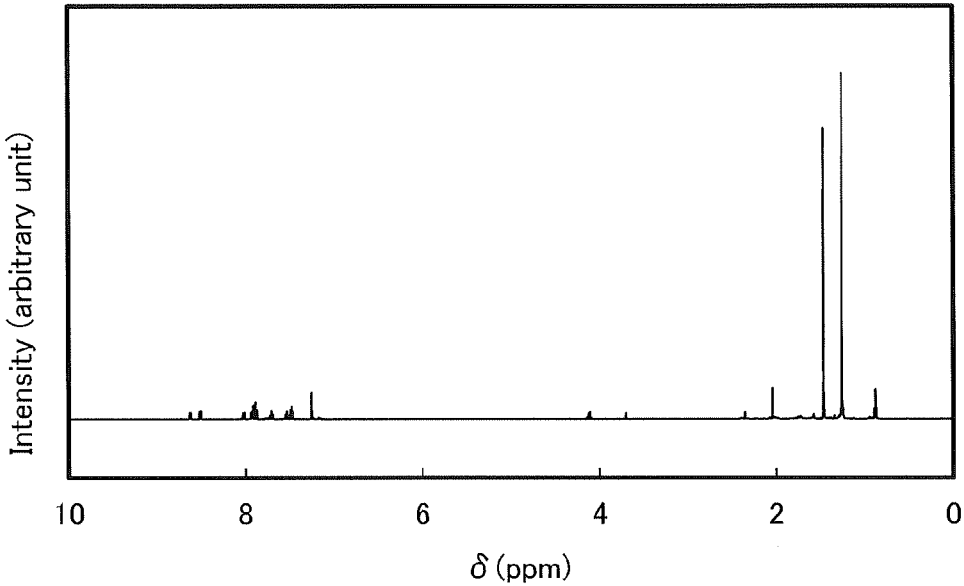

FIG. 6B

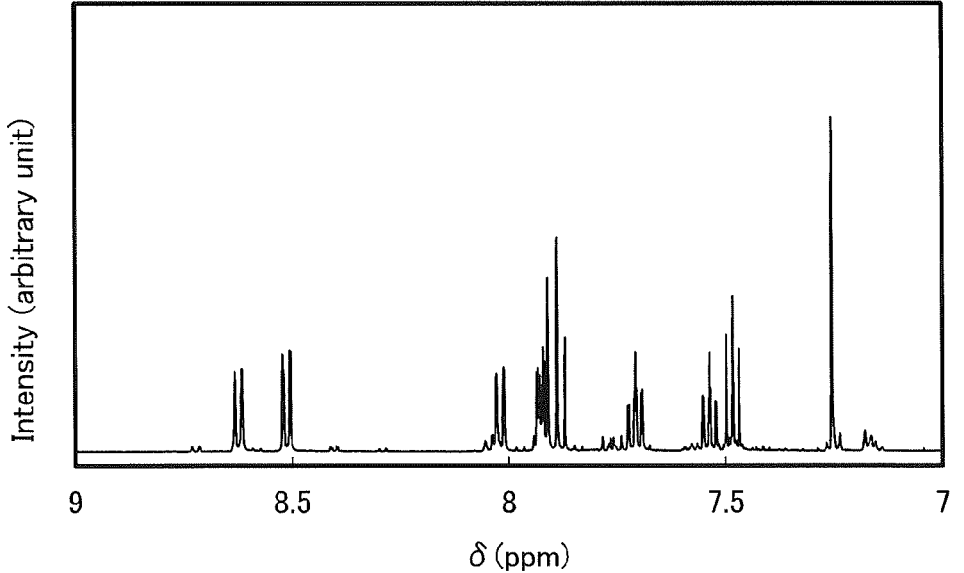

FIG. 7A

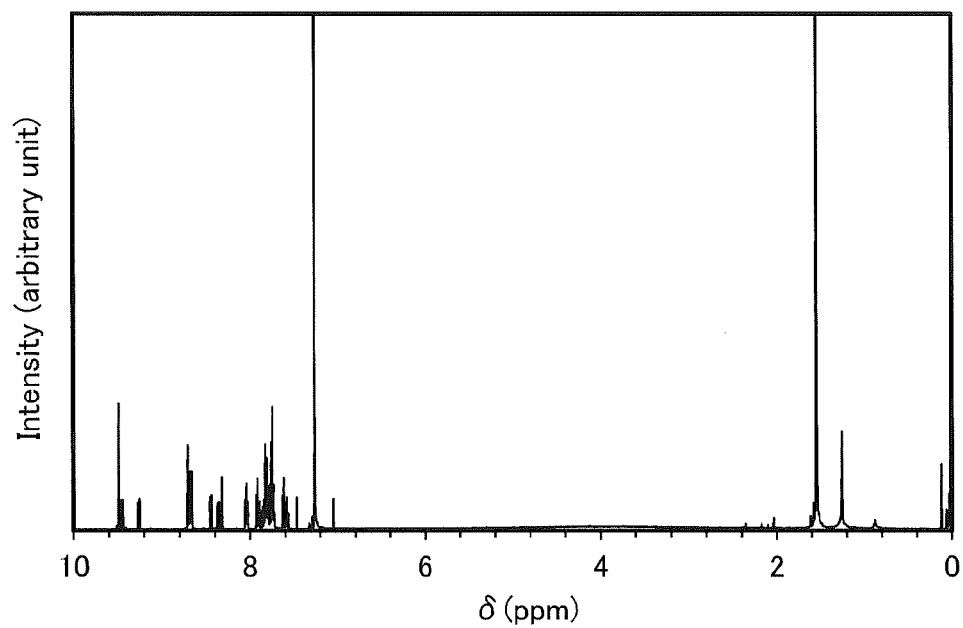

FIG. 7B

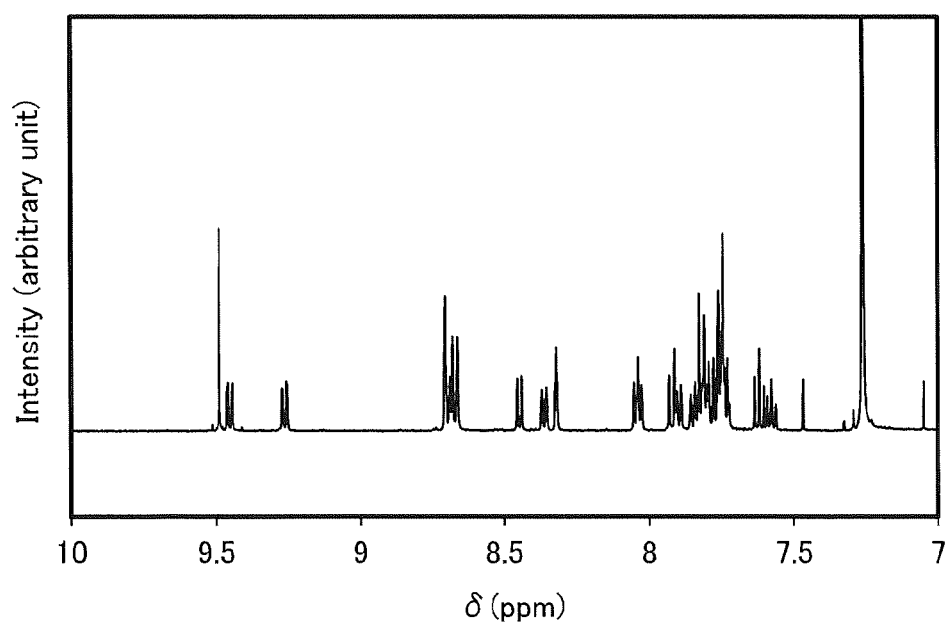

FIG. 8A

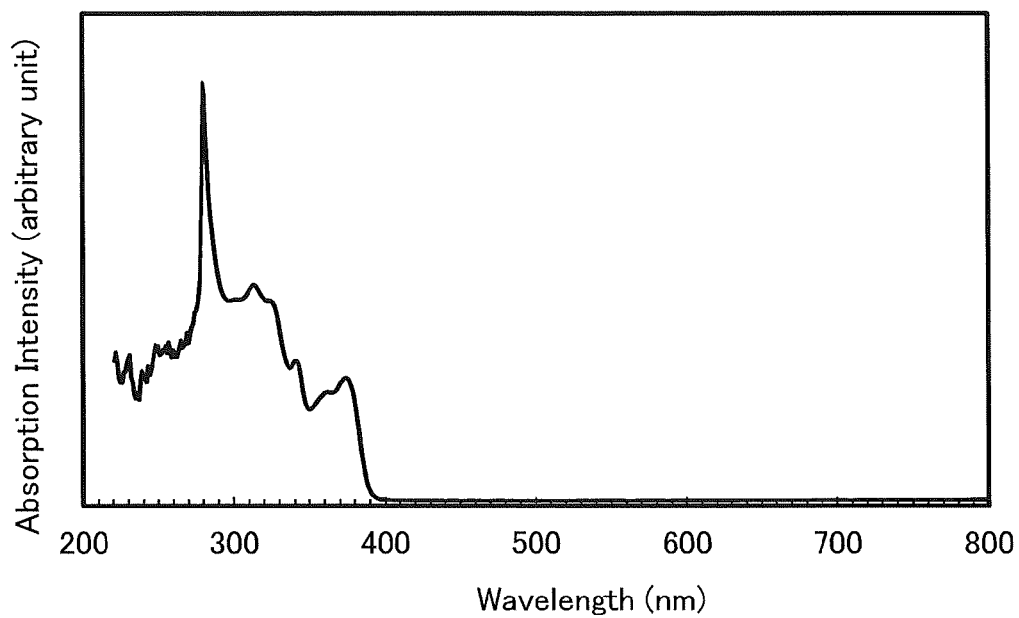

FIG. 8B

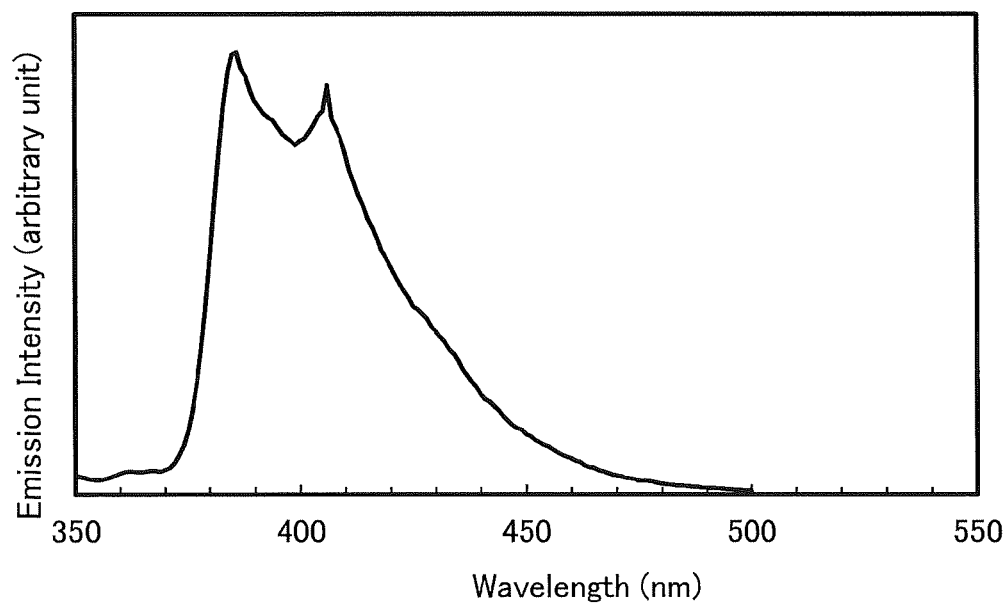

FIG. 9A

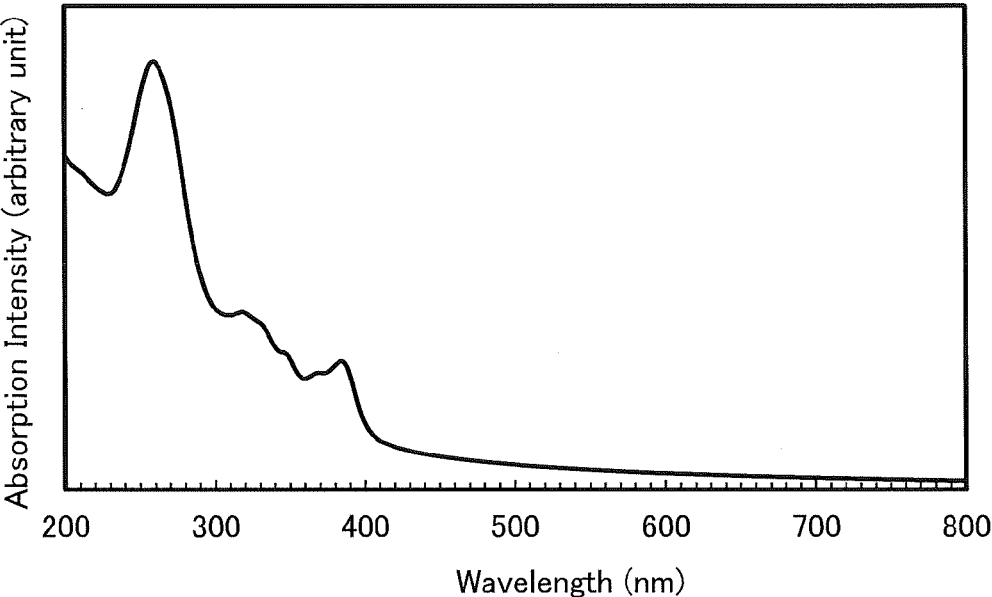

FIG. 9B

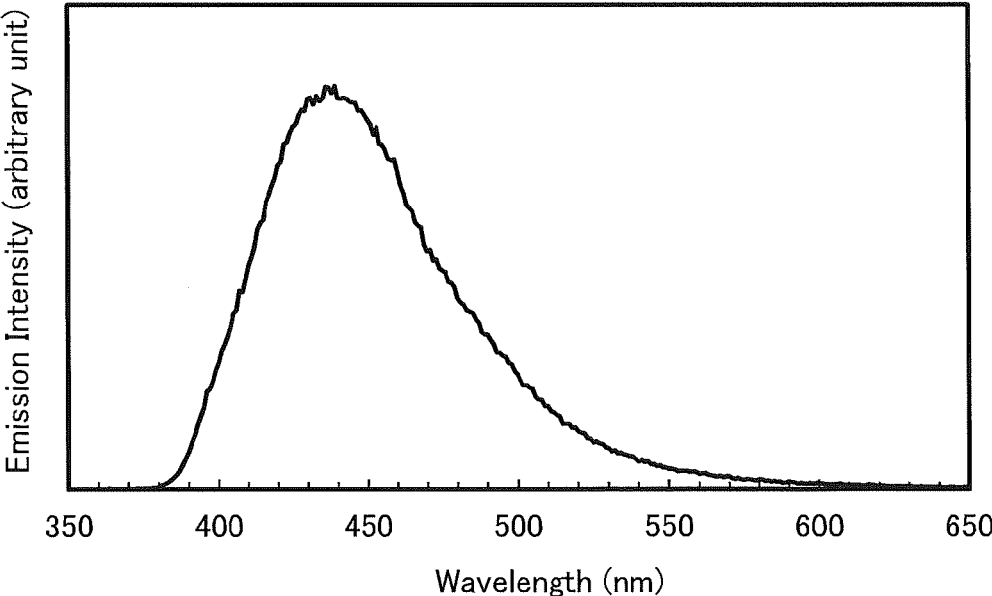

FIG. 10A

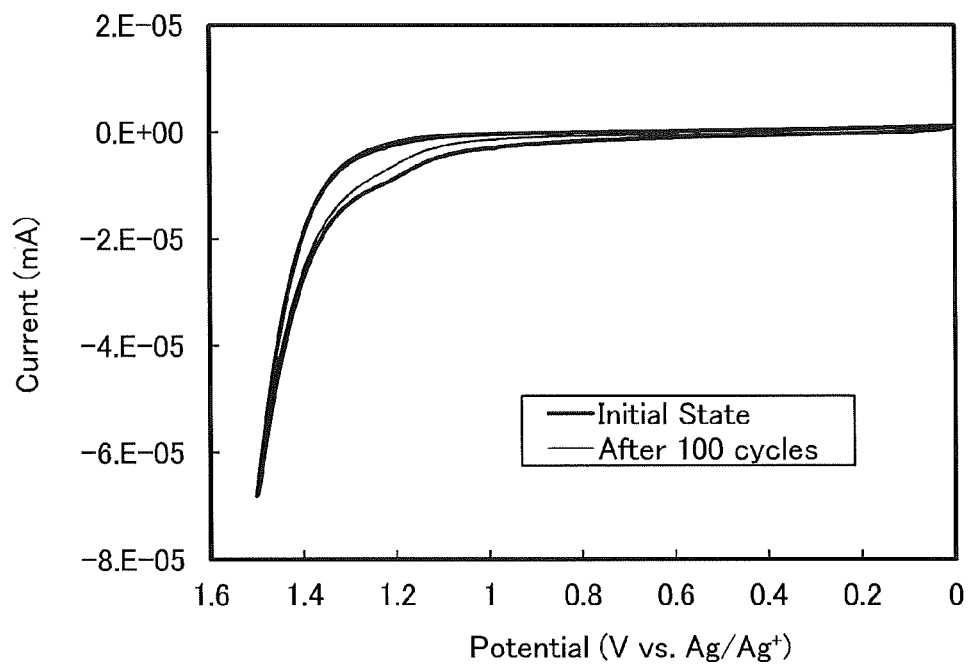

FIG. 10B

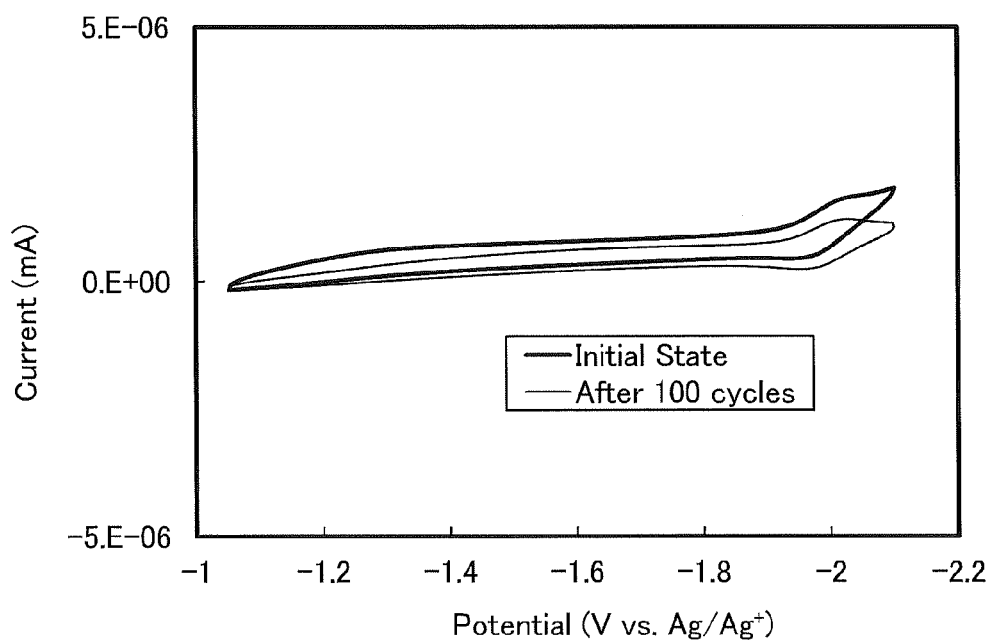

FIG. 11A

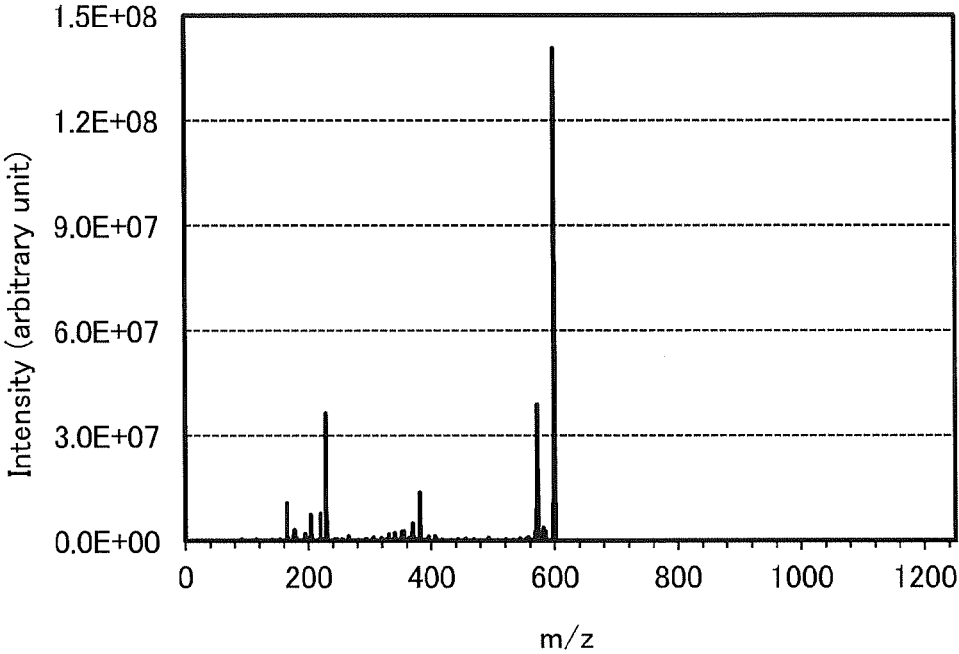

FIG. 11B

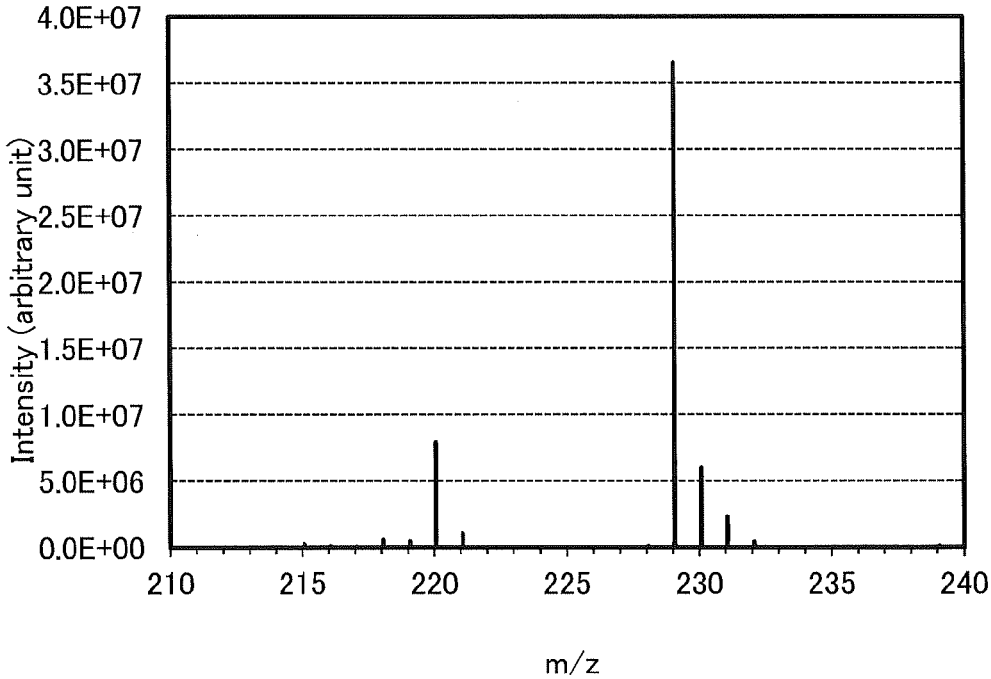

FIG. 12

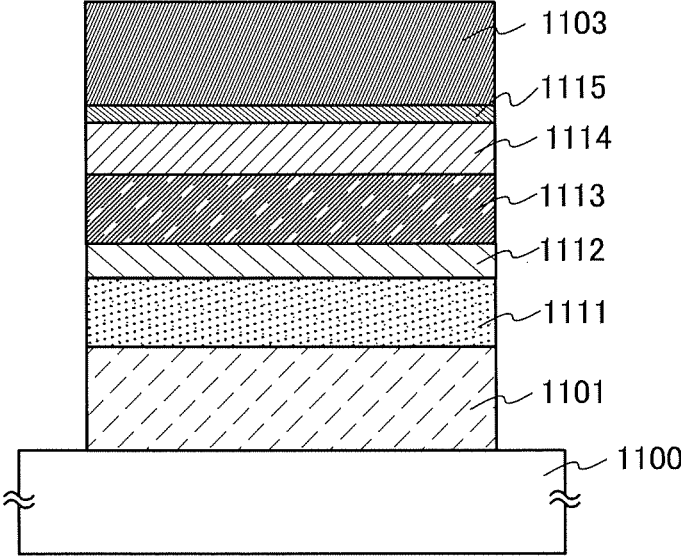

FIG. 13

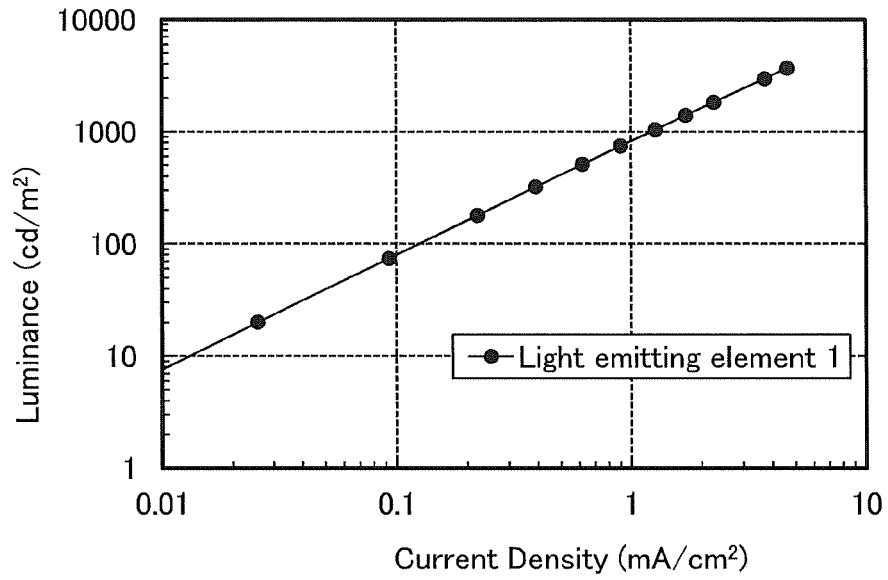

FIG. 14

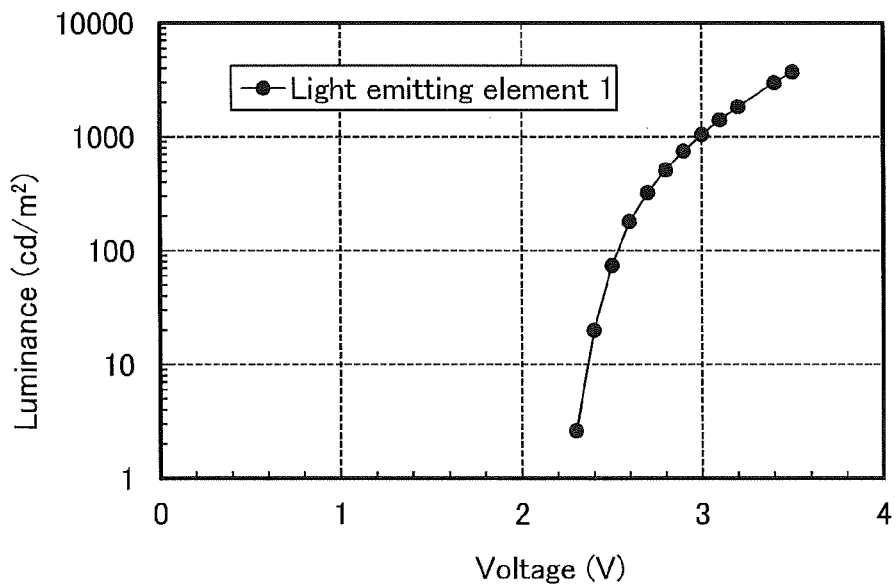

FIG. 15

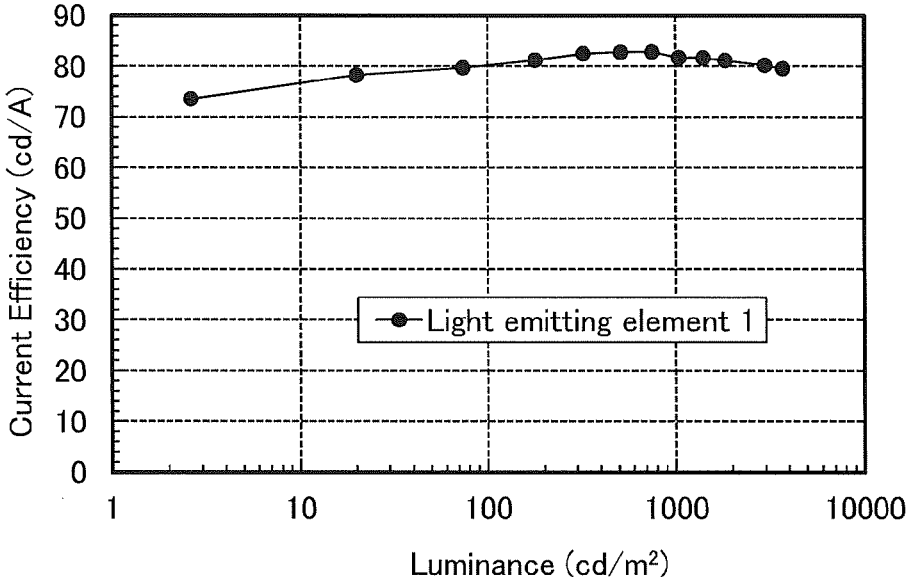

FIG. 16

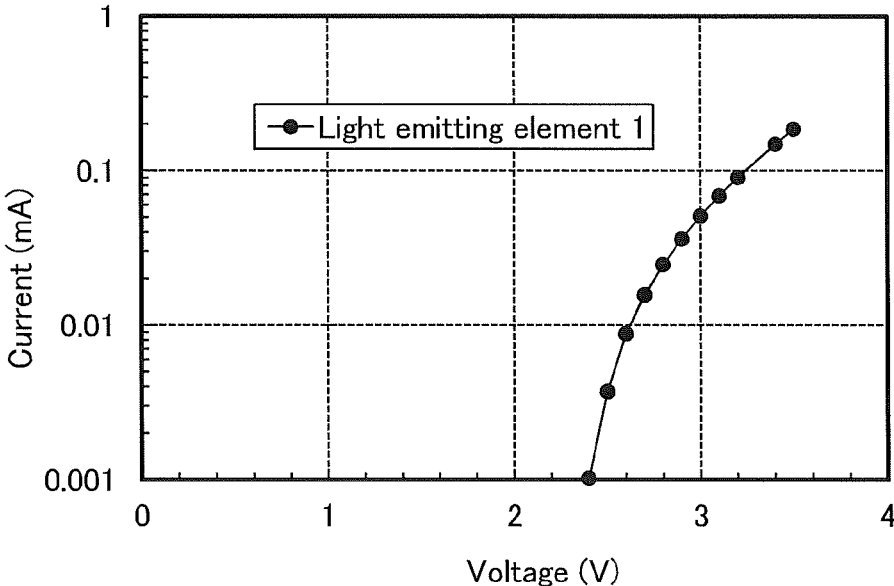

FIG. 17

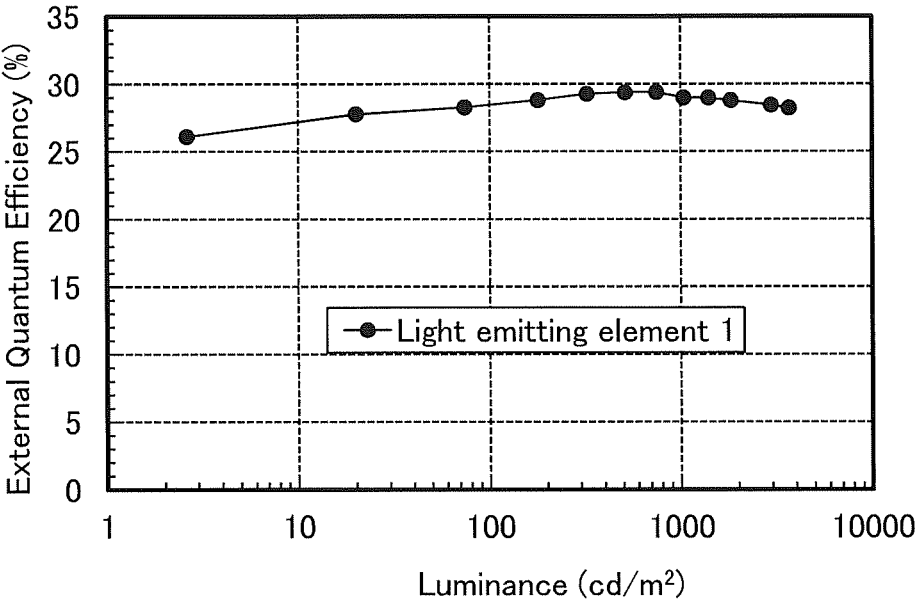

FIG. 18

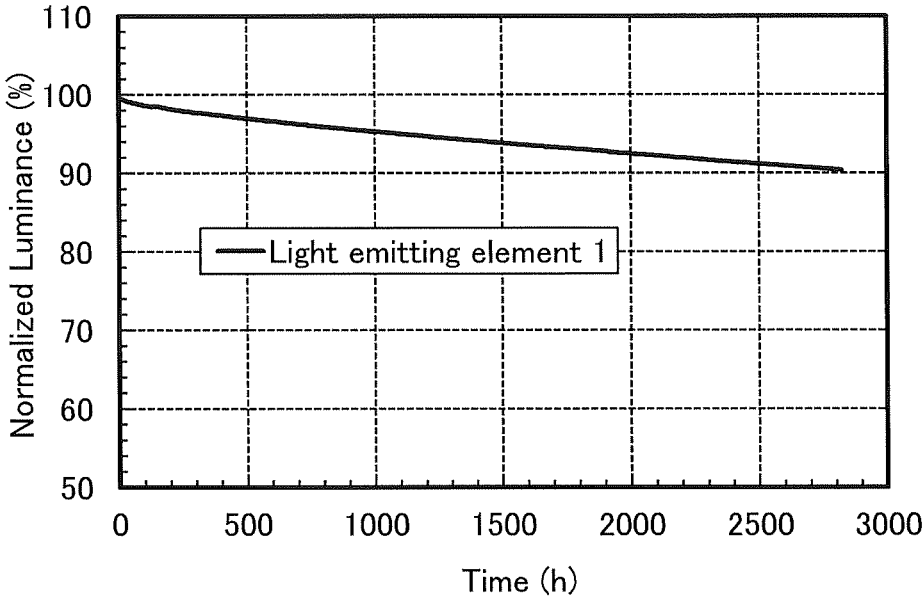

FIG. 19

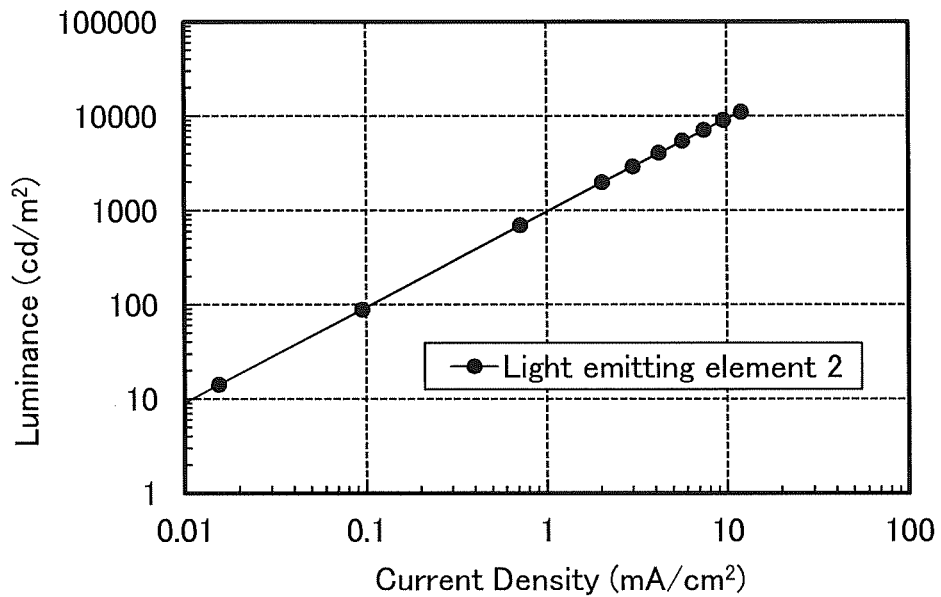

FIG. 20

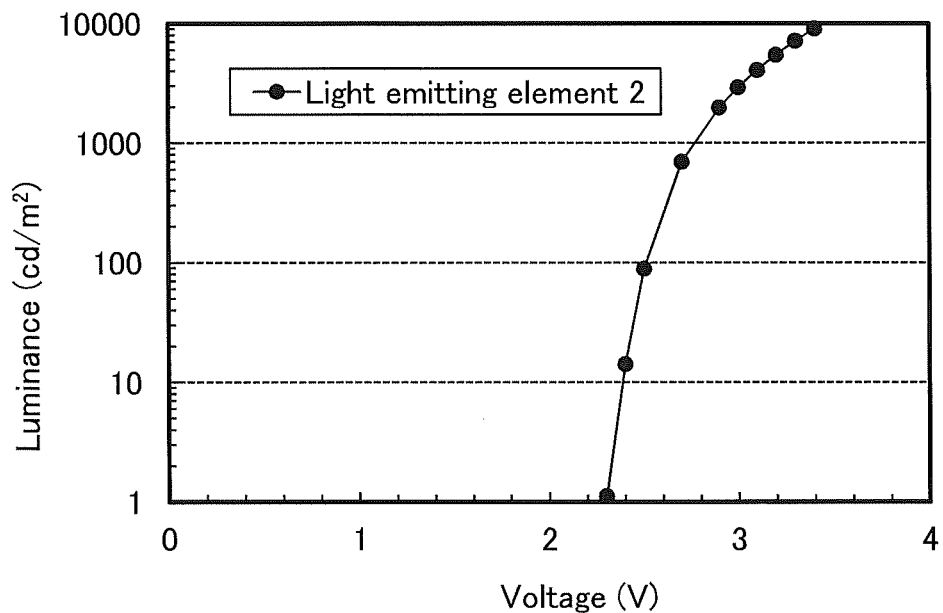

FIG. 21

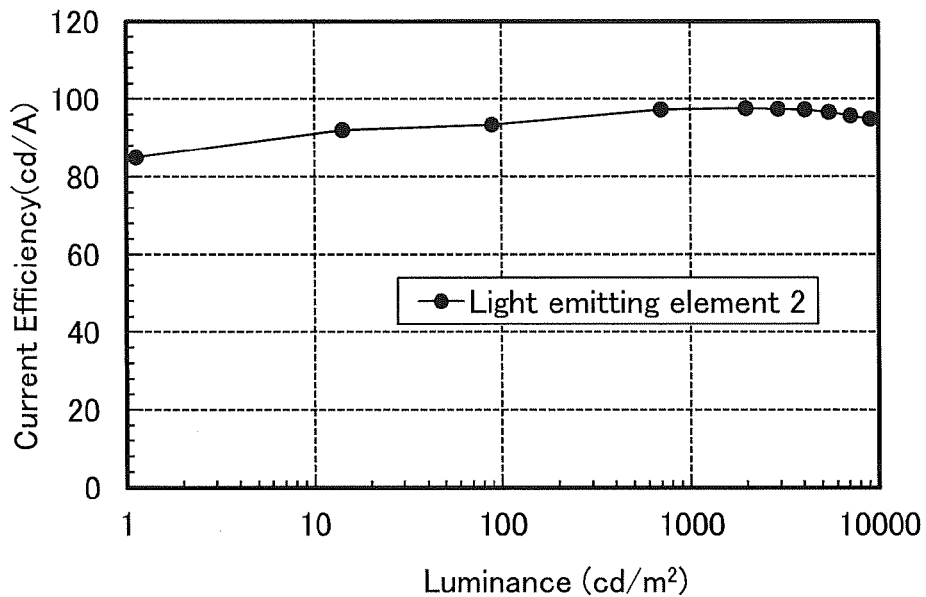

FIG. 22

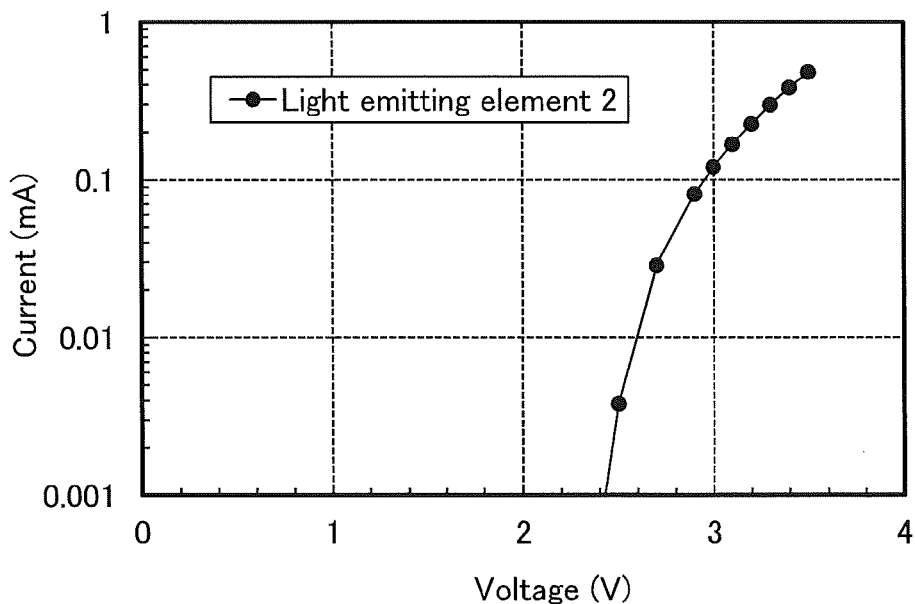

FIG. 23

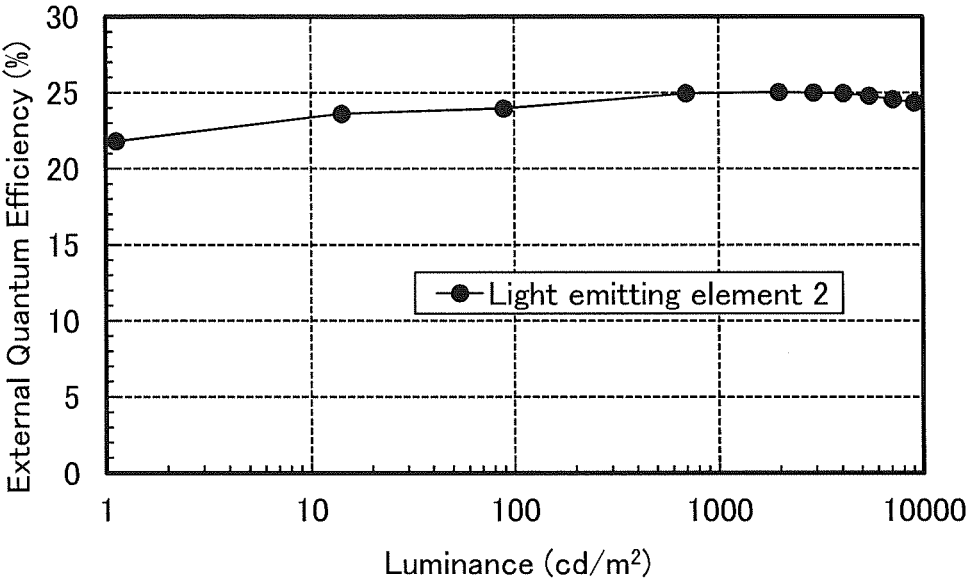

FIG. 24

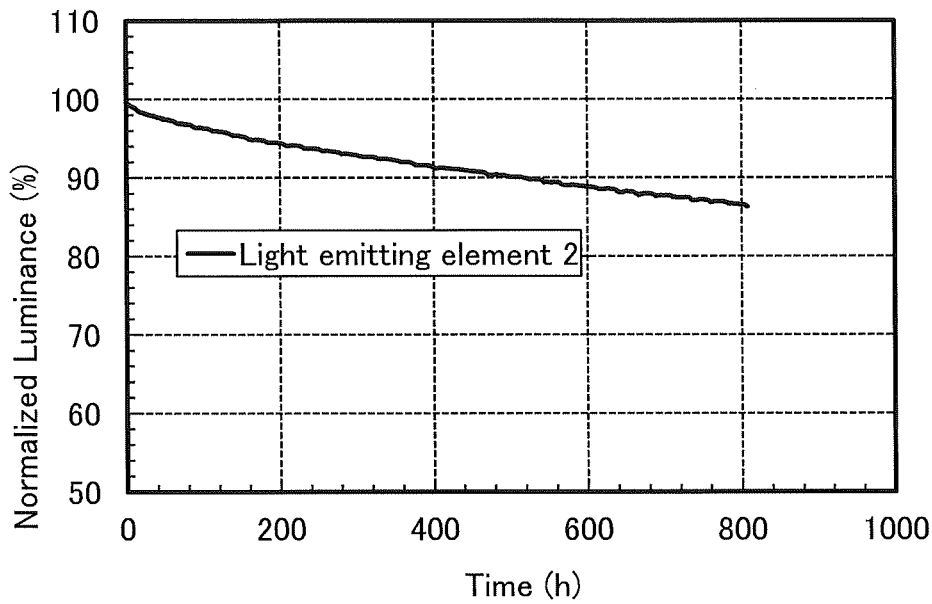

FIG. 25A

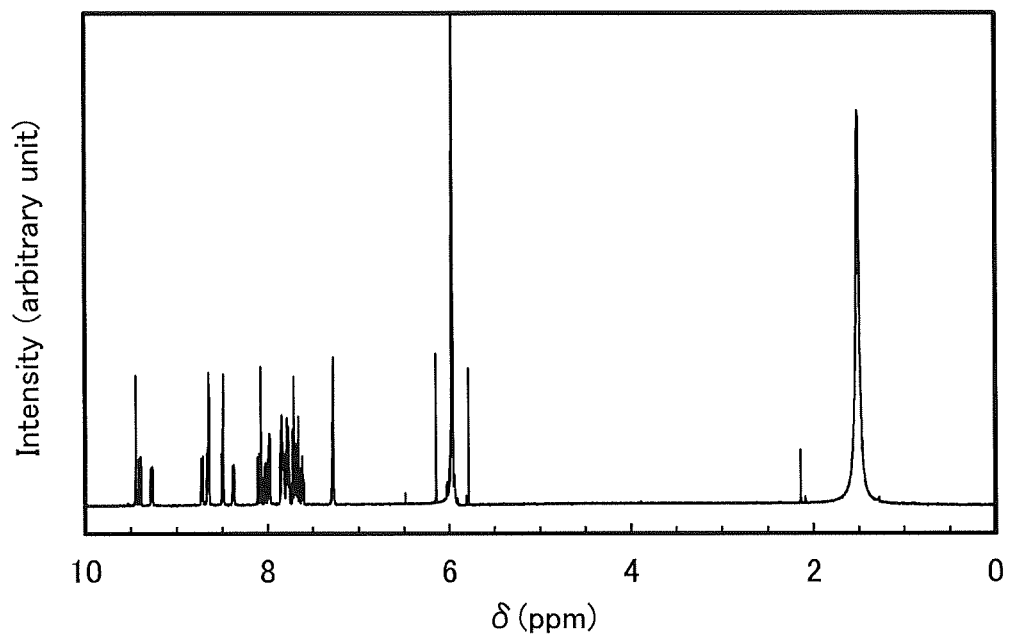

FIG. 25B

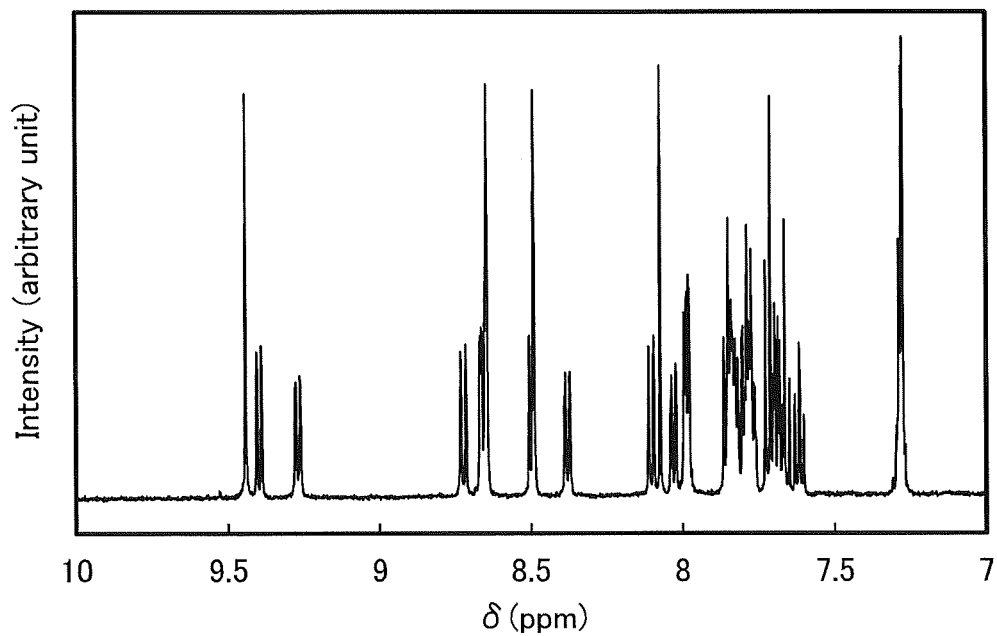

FIG. 26A

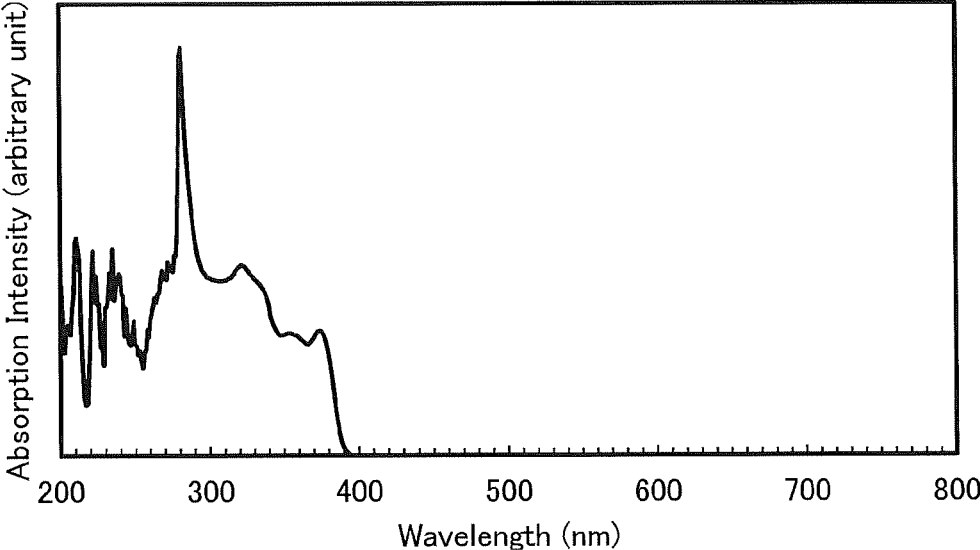

FIG. 26B

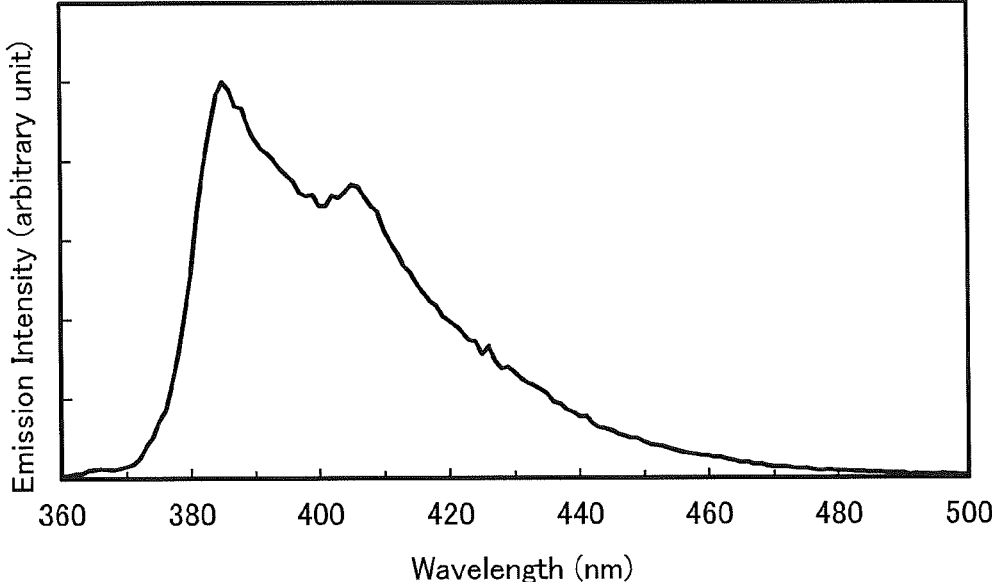

FIG. 27A

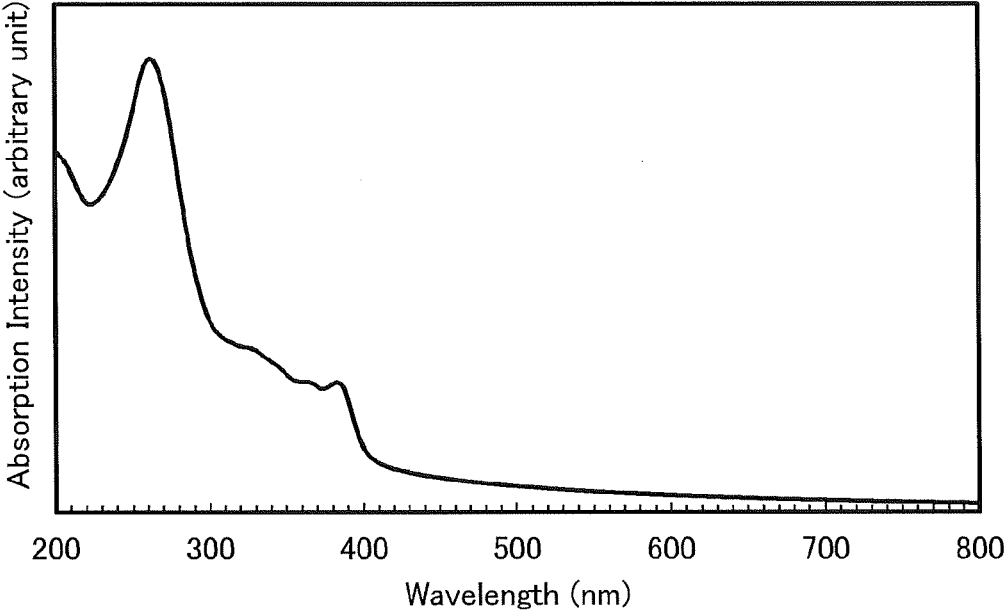

FIG. 27B

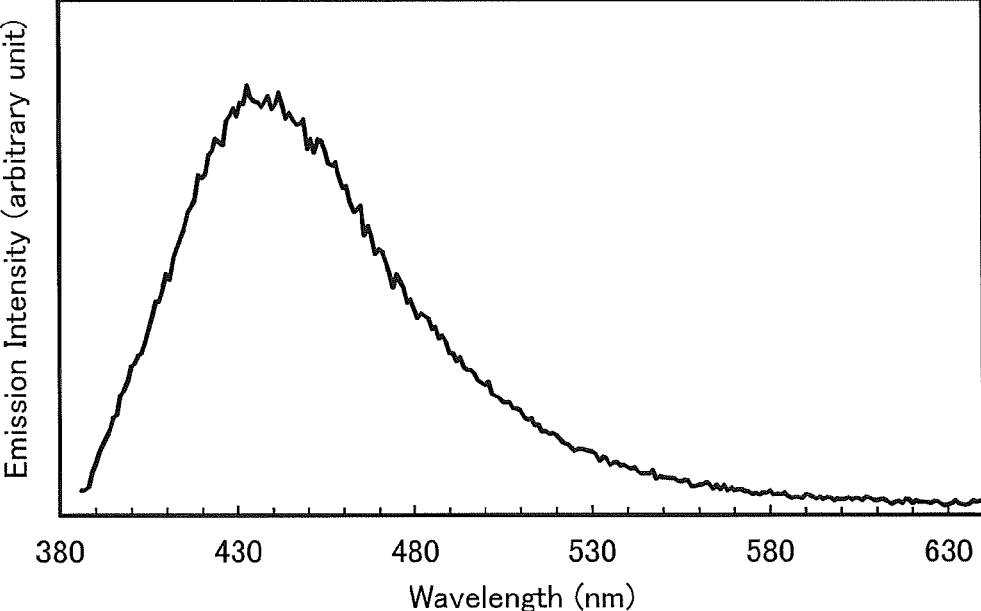

FIG. 28A

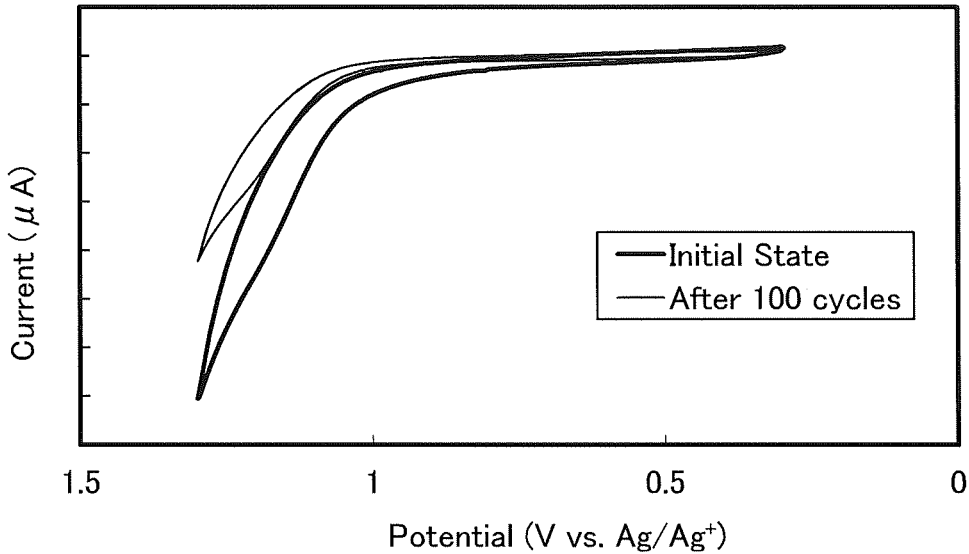

FIG. 28B

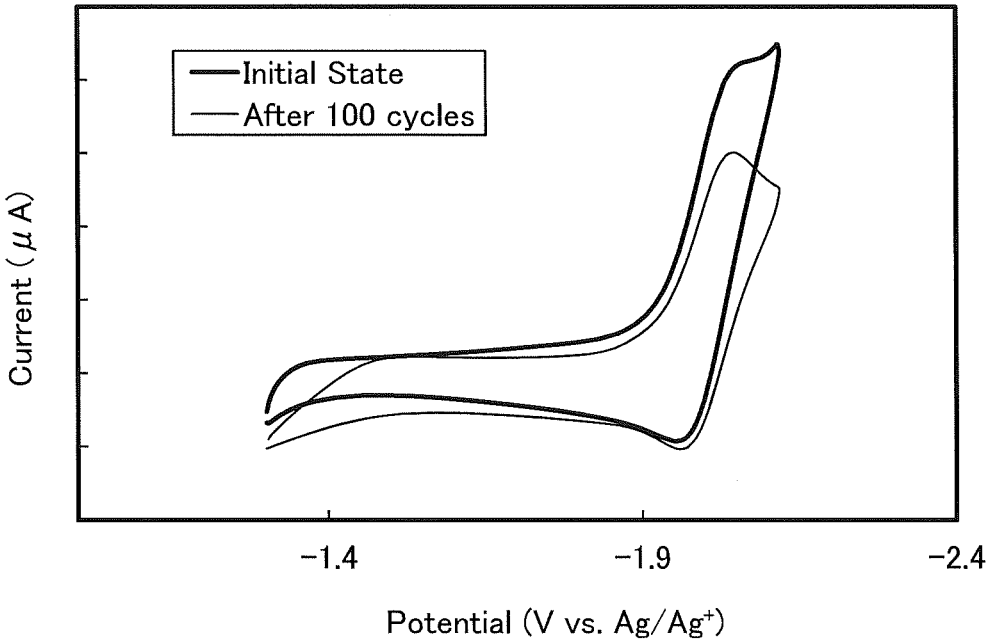

FIG. 29

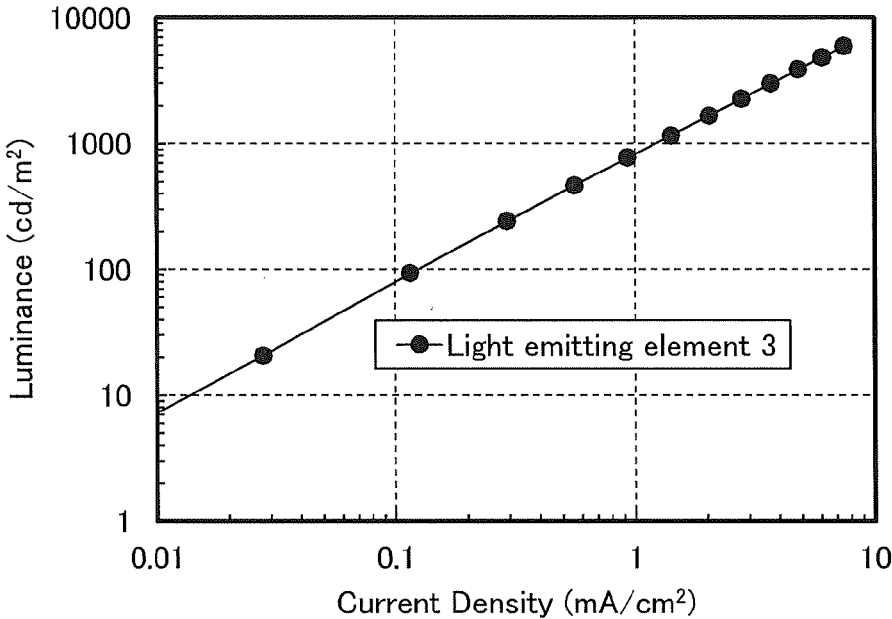

FIG. 30

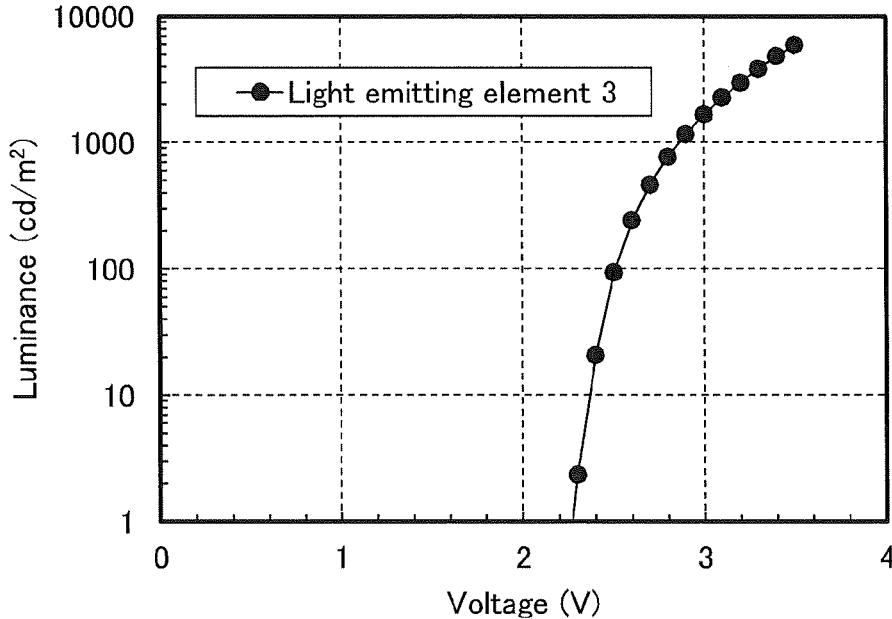

FIG. 31

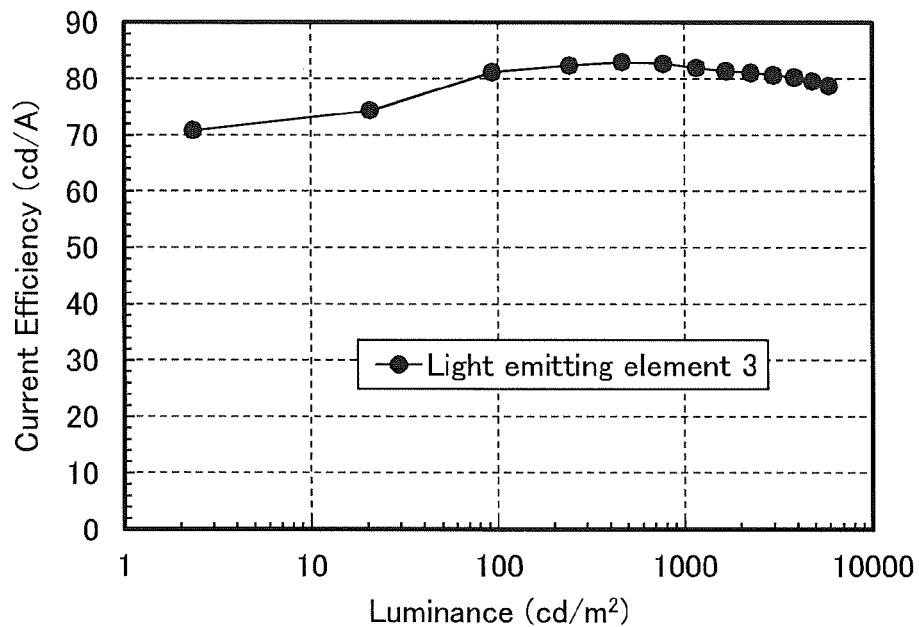

FIG. 32

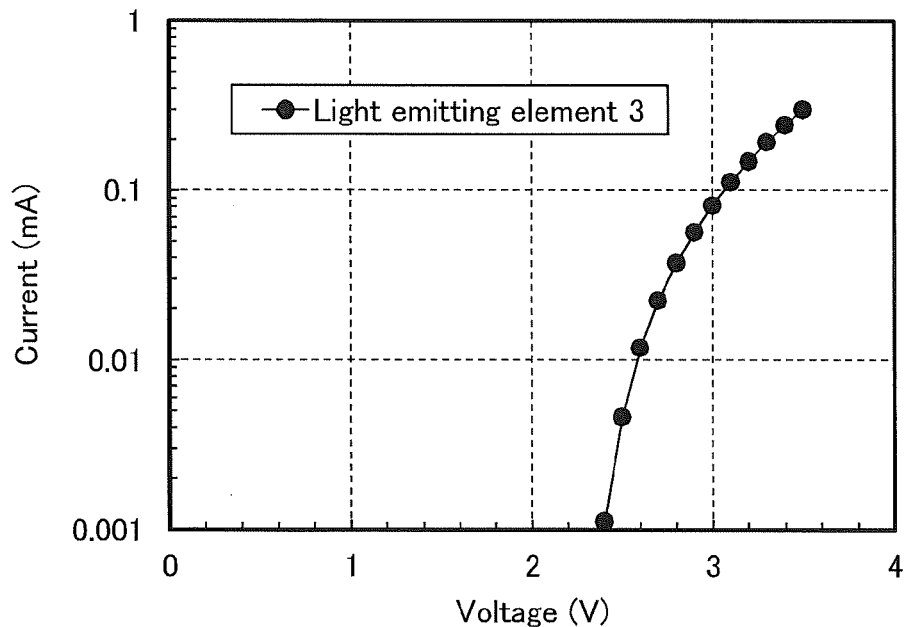

FIG. 33

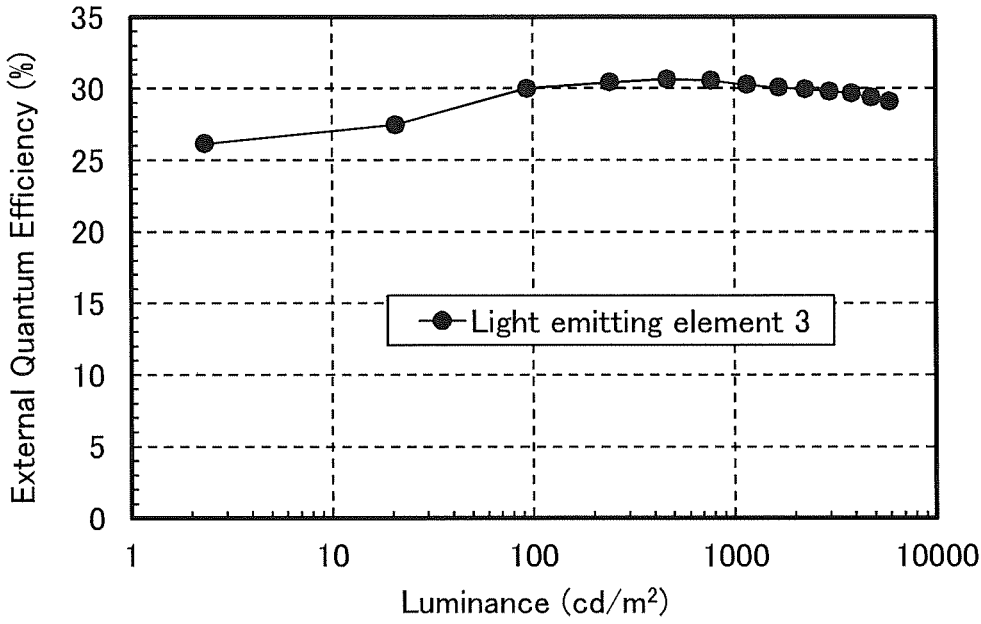

FIG. 34

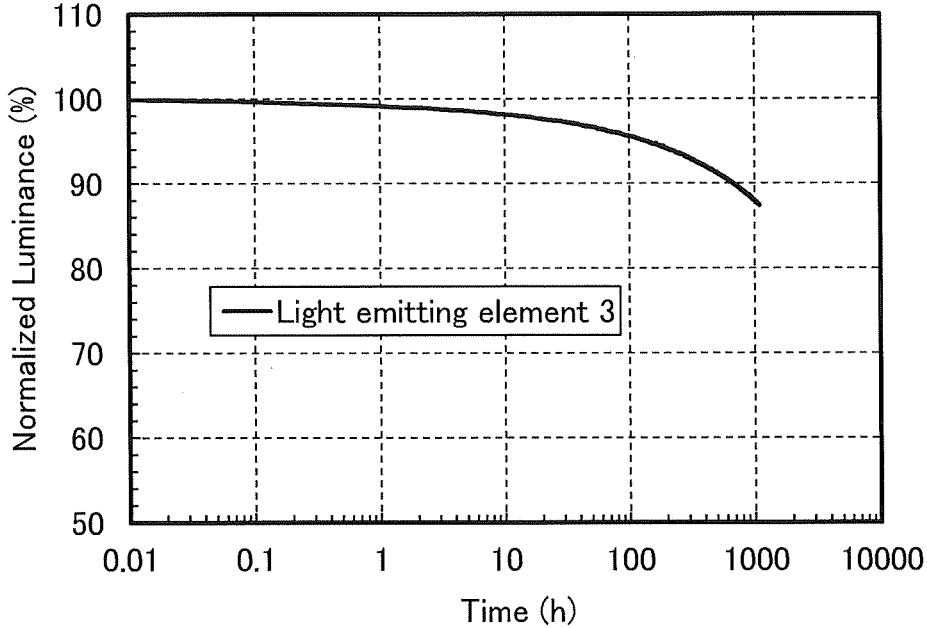

FIG. 35A

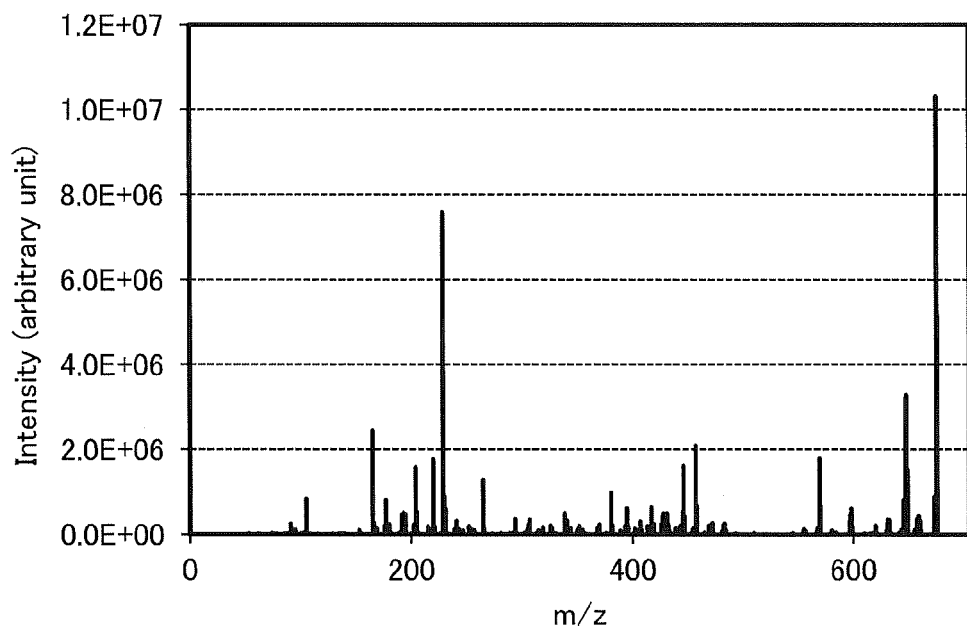
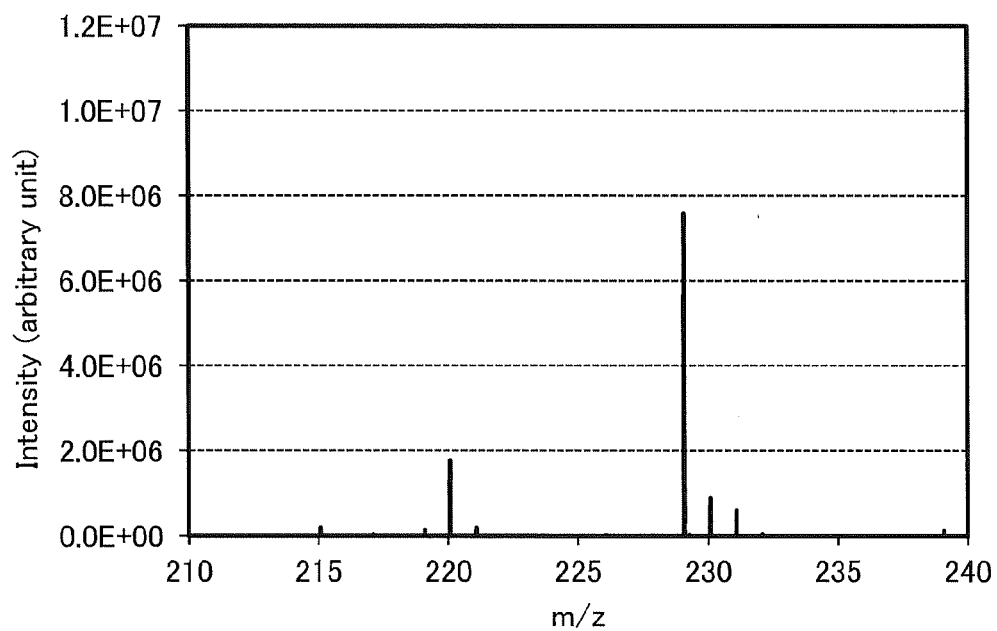

FIG. 35B



**HETEROCYCLIC COMPOUND,
LIGHT-EMITTING ELEMENT,
LIGHT-EMITTING DEVICE, ELECTRONIC
DEVICE, AND LIGHTING DEVICE**

[0001] This application is a continuation of copending U.S. application Ser. No. 14/468,954, filed on Aug. 26, 2014, which is incorporated herein by reference.

TECHNICAL FIELD

[0002] The present invention relates to an object, a method, or a manufacturing method. In addition, the present invention relates to a process, a machine, manufacture, or a composition of matter. One embodiment of the present invention relates to a semiconductor device, a display device, a light-emitting device, a lighting device, a driving method thereof, or a manufacturing method thereof. In particular, one embodiment of the present invention relates to a heterocyclic compound, a light-emitting element utilizing electroluminescence (EL) (the light-emitting element is also referred to as an EL element), a light-emitting device, an electronic device, and a lighting device.

BACKGROUND ART

[0003] In recent years, a light-emitting element using an organic compound as a light-emitting substance (the light-emitting element is also referred to as an organic EL element) has been actively researched and developed. In a basic structure of the light-emitting element, a layer containing a light-emitting substance is provided between a pair of electrodes. Voltage application to this element causes the light-emitting substance to emit light.

[0004] The light-emitting element is a self-luminous element and thus has advantages over a liquid crystal display element, such as high visibility of the pixels and no need of backlight, and is considered to be suitable as a flat panel display element. Another major advantage of the light-emitting element is that it can be fabricated to be thin and lightweight. Besides, the light-emitting element has an advantage of quite high response speed.

[0005] Since the light-emitting element can be formed in a film form, planar light emission can be provided; thus, a large-area element can be easily formed. This feature is difficult to obtain with point light sources typified by incandescent lamps and LEDs or linear light sources typified by fluorescent lamps. Thus, the light-emitting element also has great potential as a planar light source applicable to a lighting device and the like.

[0006] In the case of a light-emitting element in which a layer containing an organic compound used as a light-emitting substance is provided between a pair of electrodes, by applying a voltage to the element, electrons from a cathode and holes from an anode are injected into the layer containing the organic compound and thus a current flows. The injected electrons and holes then lead the organic compound to its excited state, so that light emission is provided from the excited organic compound.

[0007] The excited state formed by an organic compound can be a singlet excited state or a triplet excited state. Light emission from the singlet excited state (S^*) is called fluorescence, and light emission from the triplet excited state (T^*) is called phosphorescence. The statistical generation ratio thereof in the light-emitting element is considered to be $S^*:T^*=1:3$.

[0008] At room temperature, a compound capable of converting a singlet excited state into light emission (hereinafter, referred to as a fluorescent compound) exhibits only light emission from the singlet excited state (fluorescence), and light emission from the triplet excited state (phosphorescence) cannot be observed. Accordingly, the internal quantum efficiency (the ratio of the number of generated photons to the number of injected carriers) of a light-emitting element including the fluorescent compound is assumed to have a theoretical limit of 25%, on the basis of $S^*:T^*=1:3$.

[0009] In contrast, a compound capable of converting a triplet excited state into light emission (hereinafter, referred to as a phosphorescent compound) exhibits light emission from the triplet excited state (phosphorescence). Furthermore, since intersystem crossing (i.e., transition from a singlet excited state to a triplet excited state) easily occurs in a phosphorescent compound, the internal quantum efficiency can be theoretically increased to 100%. That is, higher emission efficiency can be achieved than using a fluorescent compound. For this reason, light-emitting elements using a phosphorescent compound have been under active development recently so that high-efficiency light-emitting elements can be achieved.

[0010] When a light-emitting layer of a light-emitting element is formed using the phosphorescent compound described above, in order to inhibit concentration quenching or quenching due to triplet-triplet annihilation of the phosphorescent compound, the light-emitting layer is usually formed such that the phosphorescent compound is dispersed in a matrix of another compound. Here, the compound serving as the matrix is called host material, and the compound dispersed in the matrix like the phosphorescent compound is called guest material.

[0011] When a phosphorescent compound is a guest material, a host material needs to have higher triplet excitation energy (energy difference between a ground state and a triplet excited state) than the phosphorescent compound.

[0012] Furthermore, since singlet excitation energy (energy difference between a ground state and a singlet excited state) is higher than triplet excitation energy, a substance that has high triplet excitation energy also has high singlet excitation energy. Thus, the above substance that has high triplet excitation energy is also effective in a light-emitting element using a fluorescent compound as a light-emitting substance.

[0013] Studies have been conducted on compounds having dibenzo[f,h]quinoxaline rings, which are examples of the host material used when a phosphorescent compound is a guest material (e.g., see Patent Documents 1 and 2).

REFERENCE

Patent Document

[0014] [Patent Document 1] International Publication WO 03/058667 pamphlet

[0015] [Patent Document 2] Japanese Published Patent Application No. 2007-189001

DISCLOSURE OF INVENTION

[0016] In improving element characteristics of a light-emitting element, there are many problems which depend on substances used for the light-emitting element. Therefore, improvement in an element structure, development of a

substance, and the like have been carried out in order to solve the problems. Development of light-emitting elements leaves room for improvement in terms of emission efficiency, reliability, cost, and the like.

[0017] For practical use of a display or lighting which uses a light-emitting element, a long lifetime of the light-emitting element has been required.

[0018] In view of the above, an object of one embodiment of the present invention is to provide a novel heterocyclic compound. An object of one embodiment of the present invention is to provide a novel heterocyclic compound which can be used in a light-emitting element as a host material in which a light-emitting substance is dispersed. An object of one embodiment of the present invention is to provide a heterocyclic compound having high triplet excitation energy.

[0019] An object of one embodiment of the present invention is to provide a light-emitting element with high emission efficiency. An object of one embodiment of the present invention is to provide a light-emitting element with low drive voltage. An object of one embodiment of the present invention is to provide a light-emitting element having a long lifetime. An object of one embodiment of the present invention is to provide a novel light-emitting element.

[0020] An object of one embodiment of the present invention is to provide a highly reliable light-emitting device, a highly reliable electronic device, or a highly reliable lighting device using the light-emitting element. An object of one embodiment of the present invention is to provide a light-emitting device, an electronic device, or a lighting device with low power consumption using the light-emitting element.

[0021] In one embodiment of the present invention, there is no need to achieve all the objects.

[0022] One embodiment of the present invention is a heterocyclic compound represented by General Formula (G1).

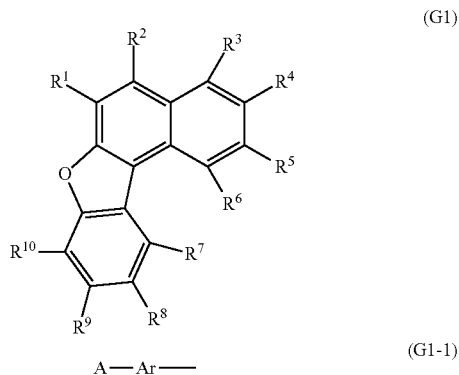

[0023] In the formula, one of R^7 to R^{10} represents a substituent represented by General Formula (G1-1); R^1 to R^6 and the others of R^7 to R^{10} separately represent any one of hydrogen, an alkyl group having 1 to 6 carbon atoms, a cycloalkyl group having 3 to 6 carbon atoms, and an aryl group having 6 to 13 carbon atoms; A represents a dibenzo[f,h]quinoxalyl group; and Ar represents an arylene group having 6 to 25 carbon atoms. The dibenzo[f,h]quinoxalyl group, the aryl group, and the arylene group are separately unsubstituted or substituted by any one of an alkyl group

having 1 to 6 carbon atoms, a cycloalkyl group having 3 to 6 carbon atoms, and an aryl group having 6 to 13 carbon atoms.

[0024] One embodiment of the present invention is a heterocyclic compound represented by General Formula (G2).

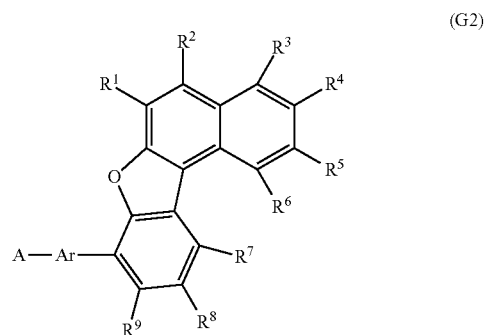

[0025] In the formula, R^1 to R^9 separately represent any one of hydrogen, an alkyl group having 1 to 6 carbon atoms, a cycloalkyl group having 3 to 6 carbon atoms, and an aryl group having 6 to 13 carbon atoms; A represents a dibenzo[f,h]quinoxalyl group; and Ar represents an arylene group having 6 to 25 carbon atoms. The dibenzo[f,h]quinoxalyl group, the aryl group, and the arylene group are separately unsubstituted or substituted by any one of an alkyl group having 1 to 6 carbon atoms, a cycloalkyl group having 3 to 6 carbon atoms, and an aryl group having 6 to 13 carbon atoms.

[0026] One embodiment of the present invention is a heterocyclic compound represented by General Formula (G3).

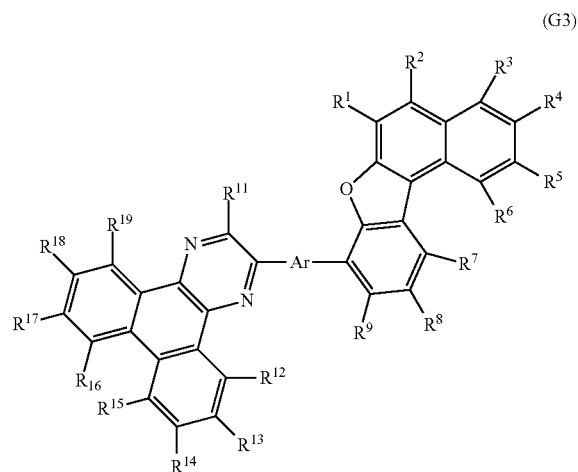

[0027] In the formula, R^1 to R^9 and R^{11} to R^{19} separately represent any one of hydrogen, an alkyl group having 1 to 6 carbon atoms, a cycloalkyl group having 3 to 6 carbon atoms, and an aryl group having 6 to 13 carbon atoms, and Ar represents an arylene group having 6 to 25 carbon atoms. The aryl group and the arylene group are separately unsubstituted or substituted by any one of an alkyl group having

1 to 6 carbon atoms, a cycloalkyl group having 3 to 6 carbon atoms, and an aryl group having 6 to 13 carbon atoms.

[0028] One embodiment of the present invention is a light-emitting element including a layer that contains any of the heterocyclic compounds having the above structures.

[0029] One embodiment of the present invention is a light-emitting device including the above-described light-emitting element in a light-emitting portion. One embodiment of the present invention is an electronic device including the light-emitting device in a display portion. One embodiment of the present invention is a lighting device including the light-emitting device in a light-emitting portion.

[0030] The light-emitting device in this specification includes an image display device that uses a light-emitting element. The category of the light-emitting device in this specification includes a module in which a light-emitting element is provided with a connector such as an anisotropic conductive film or a tape carrier package (TCP); a module in which a printed wiring board is provided at the end of a TCP; and a module in which an integrated circuit (IC) is directly mounted on a light-emitting element by a chip on glass (COG) method. In addition, a light-emitting device that is used in lighting equipment and the like are also included.

[0031] An organic compound represented by General Formula (G4), which is used in synthesis of the heterocyclic compound of one embodiment of the present invention, is also one embodiment of the present invention.

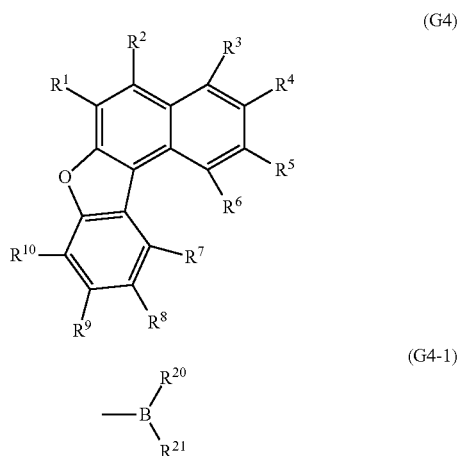

[0032] In the formula, one of R^7 to R^{10} represents a substituent represented by General Formula (G4-1); R^1 to R^6 and the others of R^7 to R^{10} separately represent any one of hydrogen, an alkyl group having 1 to 6 carbon atoms, a cycloalkyl group having 3 to 6 carbon atoms, and an aryl group having 6 to 13 carbon atoms; and R^{20} and R^{21} separately represent any one of a hydroxyl group and an alkoxy group having 1 to 6 carbon atoms and may be bonded to each other to form a ring. The aryl group and the alkoxy group are separately unsubstituted or substituted by any one of an alkyl group having 1 to 6 carbon atoms, a cycloalkyl group having 3 to 6 carbon atoms, and an aryl group having 6 to 13 carbon atoms.

[0033] An organic compound represented by Structural Formula (201), which is used in synthesis of the heterocyclic

compound of one embodiment of the present invention, is also one embodiment of the present invention.

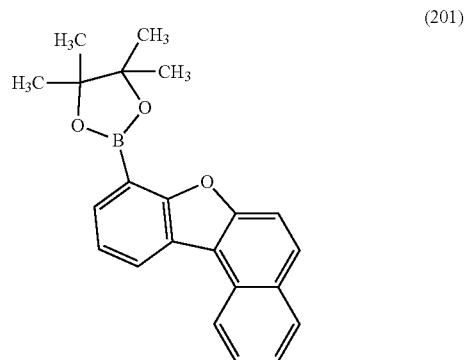

[0034] In one embodiment of the present invention, a heterocyclic compound having high triplet excitation energy can be provided. In one embodiment of the present invention, a novel heterocyclic compound which can be used in a light-emitting element as a host material in which a light-emitting substance is dispersed can be provided. In one embodiment of the present invention, a light-emitting element that has a long lifetime can be provided.

BRIEF DESCRIPTION OF DRAWINGS

[0035] FIGS. 1A to 1D each illustrate an example of a light-emitting element of one embodiment of the present invention.

[0036] FIGS. 2A and 2B illustrate an example of a light-emitting device of one embodiment of the present invention.

[0037] FIGS. 3A to 3C illustrate examples of a light-emitting device of one embodiment of the present invention.

[0038] FIGS. 4A to 4E illustrate examples of an electronic device.

[0039] FIGS. 5A and 5B illustrate examples of a lighting device.

[0040] FIGS. 6A and 6B show ^1H NMR charts of 2-(benzo[b]naphtho[1,2-d]furan-8-yl)-4,4,5,5-tetramethyl-1,3,2-dioxaborolane.

[0041] FIGS. 7A and 7B show ^1H NMR charts of 2-{3-[3-(benzo[b]naphtho[1,2-d]furan-8-yl)phenyl]phenyl}dibenzo[f,h]quinoxaline (abbreviation: 2mBnfBP-DBq).

[0042] FIGS. 8A and 8B show an absorption spectrum and an emission spectrum of a toluene solution of 2mBnfBP-DBq.

[0043] FIGS. 9A and 9B show an absorption spectrum and an emission spectrum of a thin film of 2mBnfBPDBq.

[0044] FIGS. 10A and 10B show CV measurement results of 2mBnfBPDBq.

[0045] FIGS. 11A and 11B show results of LC-MS analysis of 2mBnfBPDBq.

[0046] FIG. 12 illustrates a light-emitting element of Examples.

[0047] FIG. 13 is a graph showing luminance-current density characteristics of a light-emitting element in Example 3.

[0048] FIG. 14 is a graph showing luminance-voltage characteristics of a light-emitting element in Example 3.

[0049] FIG. 15 is a graph showing current efficiency-luminance characteristics of a light-emitting element in Example 3.

[0050] FIG. 16 is a graph showing current-voltage characteristics of a light-emitting element in Example 3.

[0051] FIG. 17 is a graph showing external quantum efficiency-luminance characteristics of a light-emitting element in Example 3.

[0052] FIG. 18 shows results of a reliability test of a light-emitting element in Example 3.

[0053] FIG. 19 is a graph showing luminance-current density characteristics of a light-emitting element in Example 4.

[0054] FIG. 20 is a graph showing luminance-voltage characteristics of a light-emitting element in Example 4.

[0055] FIG. 21 is a graph showing current efficiency-luminance characteristics of a light-emitting element in Example 4.

[0056] FIG. 22 is a graph showing current-voltage characteristics of a light-emitting element in Example 4.

[0057] FIG. 23 is a graph showing external quantum efficiency-luminance characteristics of a light-emitting element in Example 4.

[0058] FIG. 24 shows results of a reliability test of a light-emitting element in Example 4.

[0059] FIGS. 25A and 25B show ¹H NMR charts of 2-[3'-(6-phenylbenzo[b]naphtho[1,2-d]furan-8-yl)biphenyl-3-yl]dibenzo[f,h]quinoxaline (abbreviation: 2mBnfBPDBq-02).

[0060] FIGS. 26A and 26B show an absorption spectrum and an emission spectrum of a toluene solution of 2mBnfBPDBq-02.

[0061] FIGS. 27A and 27B show an absorption spectrum and an emission spectrum of a thin film of 2mBnfBPDBq-02.

[0062] FIGS. 28A and 28B show CV measurement results of 2mBnfBPDBq-02.

[0063] FIG. 29 is a graph showing luminance-current density characteristics of a light-emitting element in Example 6.

[0064] FIG. 30 is a graph showing luminance-voltage characteristics of a light-emitting element in Example 6.

[0065] FIG. 31 is a graph showing current efficiency-luminance characteristics of a light-emitting element in Example 6.

[0066] FIG. 32 is a graph showing current-voltage characteristics of a light-emitting element in Example 6.

[0067] FIG. 33 is a graph showing external quantum efficiency-luminance characteristics of a light-emitting element in Example 6.

[0068] FIG. 34 shows results of a reliability test of a light-emitting element in Example 6.

[0069] FIGS. 35A and 35B show results of LC-MS analysis of 2mBnfBPDBq-02.

BEST MODE FOR CARRYING OUT THE INVENTION

[0070] Embodiments of the present invention will be described with reference to the drawings. Note that the present invention is not limited to the following description, and it is easily understood by those skilled in the art that various changes for embodiments and details can be made without departing from the spirit and scope of the invention.

Therefore, the present invention should not be construed as being limited to the description in the following embodiments.

[0071] Note that in the structures of the invention described below, the same portions or portions having similar functions are denoted by the same reference numerals in different drawings, and description of such portions is not repeated. Furthermore, the same hatching pattern is applied to portions having similar functions, and the portions are not especially denoted by reference numerals in some cases.

[0072] In addition, the position, size, range, or the like of each structure illustrated in drawings and the like is not accurately represented in some cases for easy understanding. Therefore, the disclosed invention is not necessarily limited to the position, the size, the range, or the like disclosed in the drawings and the like.

Embodiment 1

[0073] In this embodiment, a heterocyclic compound of one embodiment of the present invention is described.

[0074] One embodiment of the present invention is a heterocyclic compound in which a dibenzo[f,h]quinoxaline skeleton and a benzo[b]naphtho[1,2-d]furan skeleton are bonded through an arylene skeleton.

[0075] A dibenzo[f,h]quinoxaline skeleton has a planar structure. An organic compound having a planar structure is easily crystallized. A light-emitting element using an organic compound that is easily crystallized has a short lifetime. However, the heterocyclic compound of one embodiment of the present invention has a sterically bulky structure since a benzo[b]naphtho[1,2-d]furan skeleton is bonded to a dibenzo[f,h]quinoxaline skeleton through an arylene skeleton. The heterocyclic compound of one embodiment of the present invention is not easily crystallized, which can inhibit a reduction in lifetime of a light-emitting element. By including a benzo[b]naphtho[1,2-d]furan skeleton, in which a benzene ring and a naphthalene ring are condensed with a furan skeleton, and a dibenzo[f,h]quinoxaline skeleton, in which two benzene rings are condensed with a quinoxaline skeleton, the heterocyclic compound of one embodiment of the present invention has extremely high heat resistance, and when the heterocyclic compound is used in a light-emitting element, the light-emitting element can have high heat resistance and a long lifetime.

[0076] When a compound that cannot easily accept electrons or holes is used as a host material in a light-emitting layer, the regions of electron-hole recombination concentrate on an interface between the light-emitting layer and a different layer, leading to a reduction in lifetime of a light-emitting element. Here, the heterocyclic compound of one embodiment of the present invention can easily accept electrons and holes since the heterocyclic compound has a dibenzo[f,h]quinoxaline skeleton as an electron-transport skeleton and a benzo[b]naphtho[1,2-d]furan skeleton as a hole-transport skeleton. Accordingly, by the use of the heterocyclic compound of one embodiment of the present invention as the host material of the light-emitting layer, electrons and holes presumably recombine in a wide region of the light-emitting layer and it is possible to inhibit a reduction in lifetime of the light-emitting element.

[0077] As compared to extension of a conjugated system in a heterocyclic compound in which a dibenzo[f,h]quinoxaline skeleton and a benzo[b]naphtho[1,2-d]furan skeleton

are directly bonded, extension of a conjugated system in the heterocyclic compound of one embodiment of the present invention in which the two skeletons are bonded through an arylene group is small; accordingly, reductions in band gap and triplet excitation energy can be prevented. Moreover, the heterocyclic compound of one embodiment of the present invention is also advantageous in that its heat resistance and film quality are high.

[0078] The heterocyclic compound of one embodiment of the present invention has a wide band gap. Accordingly, the heterocyclic compound can be favorably used as a host material, in which a light-emitting substance is dispersed, of a light-emitting layer in a light-emitting element. Furthermore, since the heterocyclic compound of one embodiment of the present invention has triplet excitation energy high enough to excite a phosphorescent compound emitting light in a wavelength range from red to green, the heterocyclic compound can be favorably used as a host material in which the phosphorescent compound is dispersed.

[0079] Furthermore, since the heterocyclic compound of one embodiment of the present invention has a high electron-transport property, the heterocyclic compound can be suitably used as a material for an electron-transport layer in a light-emitting element.

[0080] Thus, the heterocyclic compound of one embodiment of the present invention can be suitably used as a material for an organic device such as a light-emitting element or an organic transistor.

[0081] One embodiment of the present invention is a heterocyclic compound represented by General Formula (G1). In the case where a substituent represented by General Formula (G1-1) is bonded to the benzene ring of benzo[b]naphtho[1,2-d]furan, the heterocyclic compound can have a higher triplet excitation energy level (T_1 level) than in the case where the substituent is bonded to the naphthalene ring (than in the case where R^1 is the substituent, particularly).

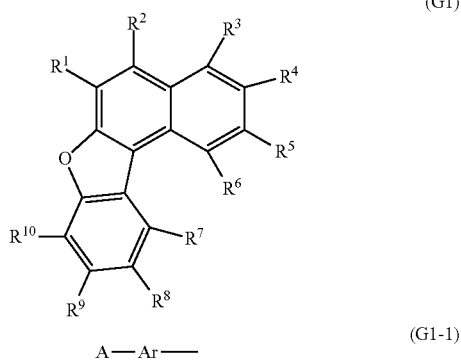

[0082] In the formula, R^1 to R^6 separately represent any one of hydrogen, an alkyl group having 1 to 6 carbon atoms, a cycloalkyl group having 3 to 6 carbon atoms, and an aryl group having 6 to 13 carbon atoms; one of R^7 to R^{10} represents a substituent represented by General Formula (G1-1); the others of R^7 to R^{10} separately represent any one of hydrogen, an alkyl group having 1 to 6 carbon atoms, a

cycloalkyl group having 3 to 6 carbon atoms, and an aryl group having 6 to 13 carbon atoms; A represents a dibenzo[f,h]quinoxaliny group; and Ar represents an arylene group having 6 to 25 carbon atoms. The dibenzo[f,h]quinoxaliny group, the aryl group, and the arylene group are separately unsubstituted or substituted by any one of an alkyl group having 1 to 6 carbon atoms, a cycloalkyl group having 3 to 6 carbon atoms, and an aryl group having 6 to 13 carbon atoms.

[0083] In particular, the substituent represented by General Formula (G1-1) is preferably bonded to the 8-position of benzo[b]naphtho[1,2-d]furan skeleton in General Formula (G1) (that is, R^{10} in General Formula (G1) is preferably the substituent represented by General Formula (G1-1)) because a high T_1 level can be achieved.

[0084] Specifically, one embodiment of the present invention is a heterocyclic compound represented by General Formula (G2).

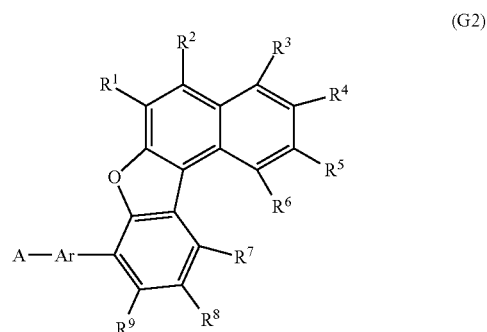

[0085] In the formula, R^1 to R^9 separately represent any one of hydrogen, an alkyl group having 1 to 6 carbon atoms, a cycloalkyl group having 3 to 6 carbon atoms, and an aryl group having 6 to 13 carbon atoms; A represents a dibenzo[f,h]quinoxaliny group; and Ar represents an arylene group having 6 to 25 carbon atoms. The dibenzo[f,h]quinoxaliny group, the aryl group, and the arylene group are separately unsubstituted or substituted by any one of an alkyl group having 1 to 6 carbon atoms, a cycloalkyl group having 3 to 6 carbon atoms, and an aryl group having 6 to 13 carbon atoms.

[0086] In the heterocyclic compound represented by General Formula (G2), Ar is preferably bonded to the 2-position, the 6-position, or the 7-position of the dibenzo[f,h]quinoxaline skeleton for easier synthesis, higher purity, a higher T_1 level, and the like. Ar is preferably bonded to the 2-position because the heterocyclic compound can be more easily synthesized and can have high purity more easily and thus can be provided at lower cost than in the case where Ar is bonded to the 6-position or the 7-position. Ar is preferably bonded to the 6-position because a T_1 level can be higher than in the case where Ar is bonded to the 2-position or the 7-position. Ar is preferably bonded to the 7-position because a T_1 level can be higher than in the case where Ar is bonded to the 2-position.

[0087] One embodiment of the present invention is a heterocyclic compound represented by General Formula (G3).

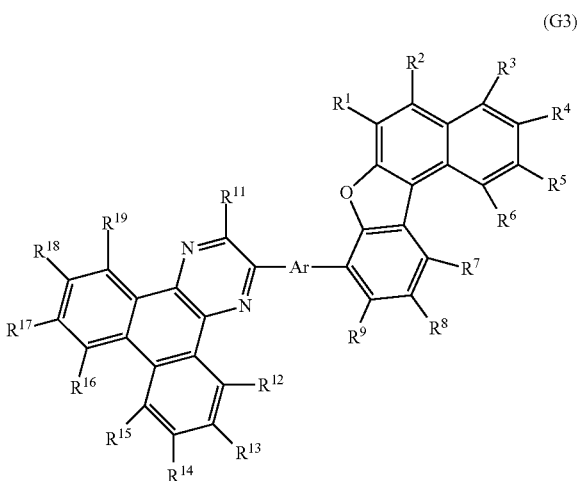

[0088] In the formula, R^1 to R^9 and R^{11} to R^{19} separately represent any one of hydrogen, an alkyl group having 1 to 6 carbon atoms, a cycloalkyl group having 3 to 6 carbon atoms, and an aryl group having 6 to 13 carbon atoms, and Ar represents an arylene group having 6 to 25 carbon atoms. The aryl group and the arylene group are separately unsubstituted or substituted by any one of an alkyl group having 1 to 6 carbon atoms, a cycloalkyl group having 3 to 6 carbon atoms, and an aryl group having 6 to 13 carbon atoms. At least one of R^1 to R^9 is preferably a benzene ring because higher heat resistance can be achieved. Specifically, R^1 is preferably a phenyl group because the synthesis is facilitated. Examples of a heterocyclic compound with such a structure include the compound described later in Synthesis Example 2.

[0089] Specific examples of the structure of Ar in General Formulae (G1-1), (G2), and (G3) include substituents represented by Structural Formulae (1-1) to (1-18). Note that Ar may further have, as a substituent, any one of an alkyl group having 1 to 4 carbon atoms, a cycloalkyl group having 3 to 6 carbon atoms, and an aryl group having 6 to 13 carbon atoms. As examples of the aryl group having 6 to 13 carbon atoms, a phenyl group, a naphthyl group, a fluorenyl group, and the like can be given. Specific examples of Ar having a substituent are illustrated by Structural Formulae (1-12), (1-13), (1-15), and (1-18). Note that Ar having a substituent is not limited to these examples.

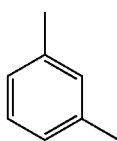
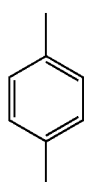

-continued

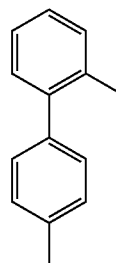
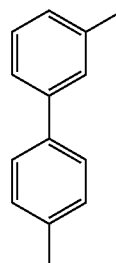
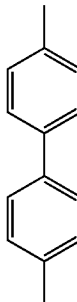
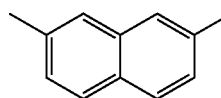
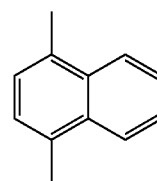
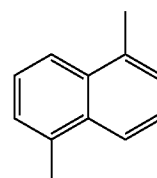
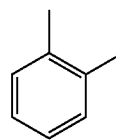

-continued

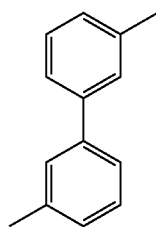

(1-10)

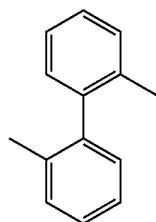

(1-11)

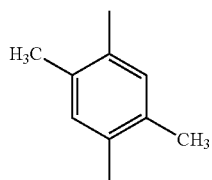

(1-12)

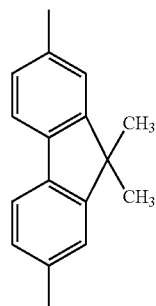

(1-13)

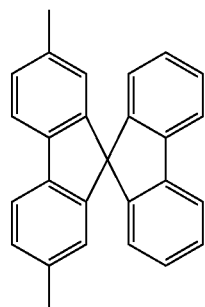

(1-14)

-continued

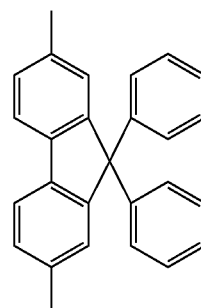

(1-15)

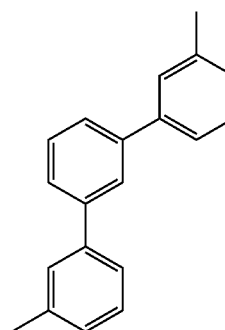

(1-16)

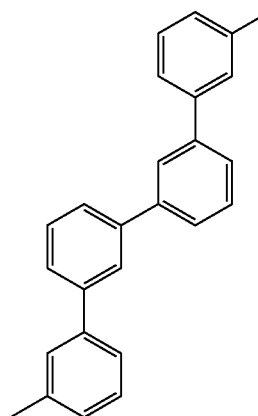

(1-17)

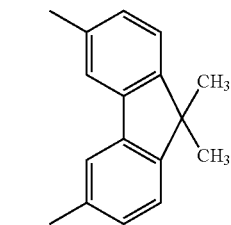

(1-18)

[0090] Ar preferably has one or more kinds of rings selected from a benzene ring, a fluorene ring, and a naphthalene ring. Ar is preferably a substituent including one or more kinds of rings selected from a benzene ring, a fluorene ring, and a naphthalene ring, examples of which include a phenylene group, a biphenylene group, a terphenylene group, a quaterphenylene group, a naphthalene-diyl group, and a 9H-fluorene-diyl group. In that case, the heterocyclic compound of one embodiment of the present invention can have high triplet excitation energy.

[0091] Specific examples of R^1 to R^{19} in General Formulae (G1) to (G3) include substituents represented by Structural Formulae (2-1) to (2-23). Note that when R^1 to R^{19} represent aryl groups, R^1 to R^{19} may further have, as a substituent, any one of an alkyl group having 1 to 4 carbon atoms, a cycloalkyl group having 3 to 6 carbon atoms, and an aryl group having 6 to 13 carbon atoms. As examples of the aryl group having 6 to 13 carbon atoms, a phenyl group, a naphthyl group, a fluorenyl group, and the like can be given. Specific examples of the aryl group having a substituent are illustrated by Structural Formulae (2-13) to (2-22). Note that R^1 to R^{19} each having a substituent are not limited to these examples.

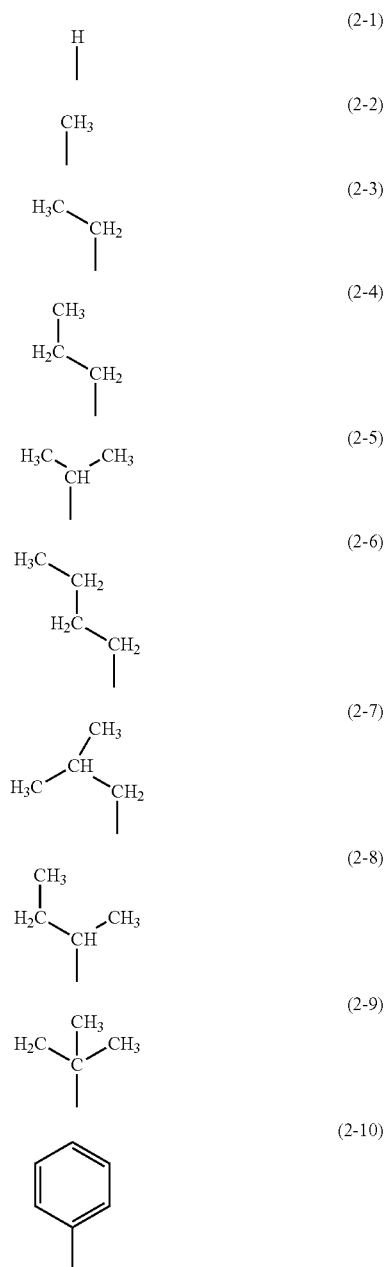

-continued

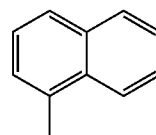

(2-11)

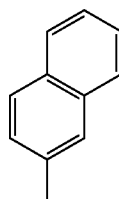

(2-12)

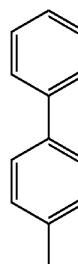

(2-13)

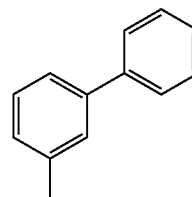

(2-14)

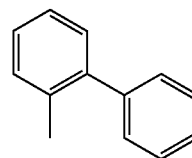

(2-15)

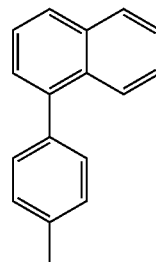

(2-16)

-continued

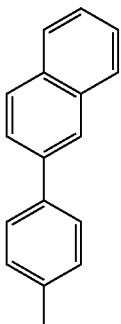

(2-17)

-continued

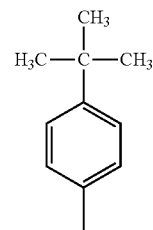

(2-20)

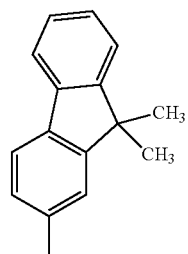

(2-18)

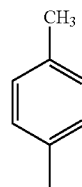

(2-21)

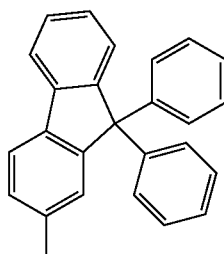

(2-19)

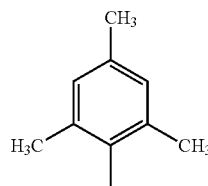

(2-22)

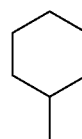

(2-23)

[0092] Specific examples of the heterocyclic compound of one embodiment of the present invention include heterocyclic compounds represented by Structural Formulae (100) to (155). However, the present invention is not limited to these structural formulae.

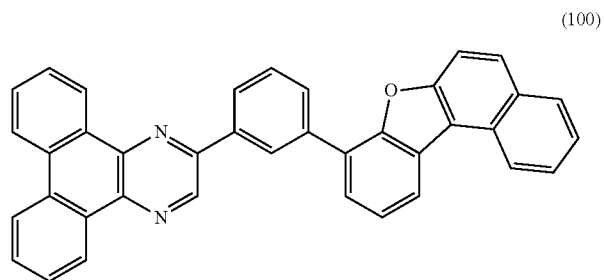

(100)

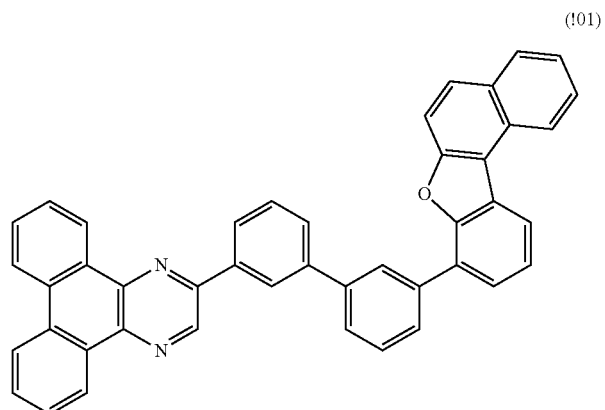

(101)

-continued

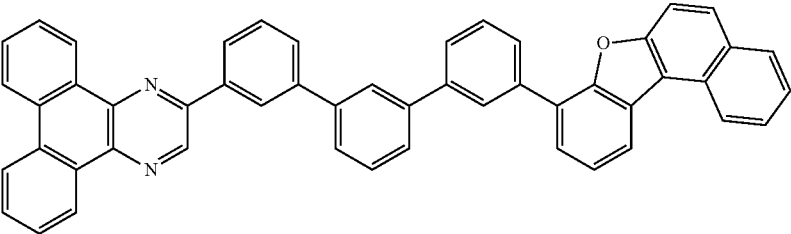

(102)

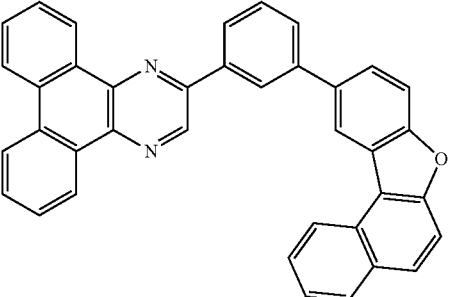

(103)

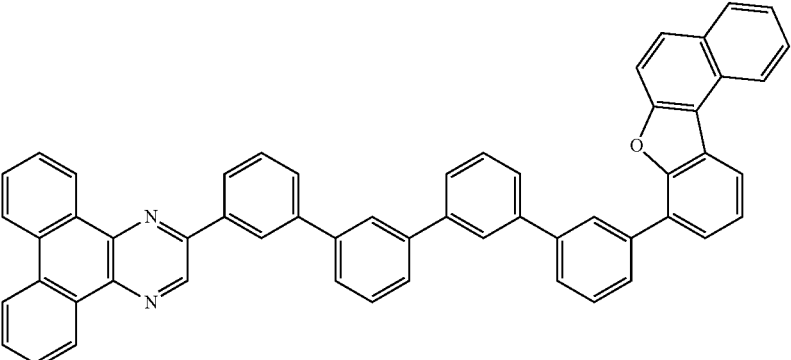

(104)

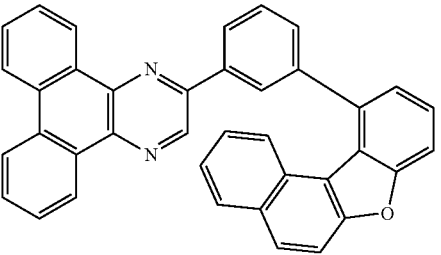

(105)

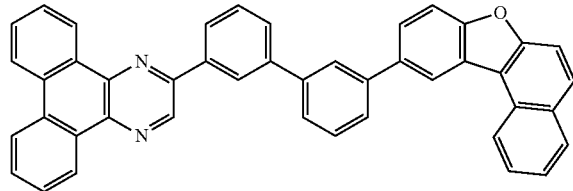

(106)

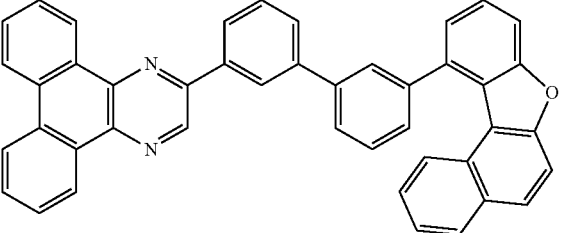

(107)

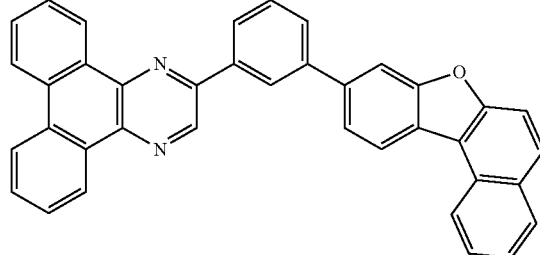

(108)

-continued
(109)

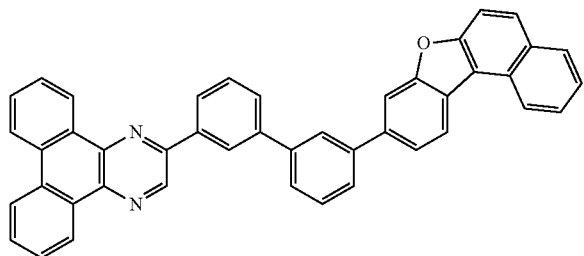

(111)

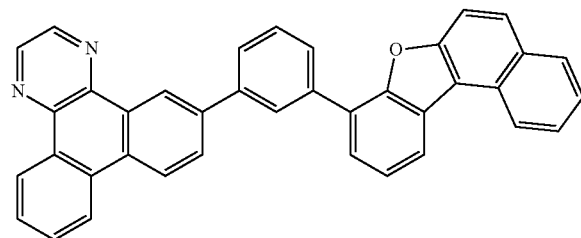

(110)

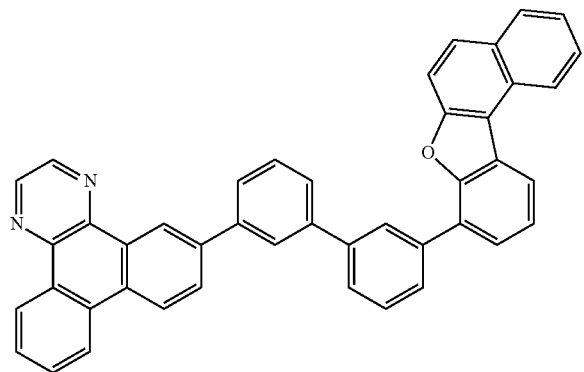

(113)

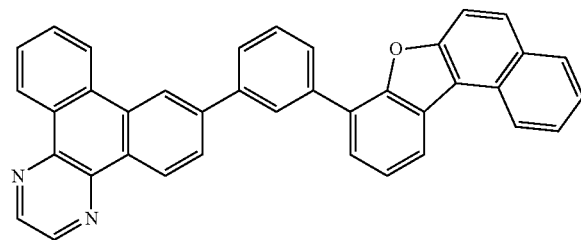

(112)

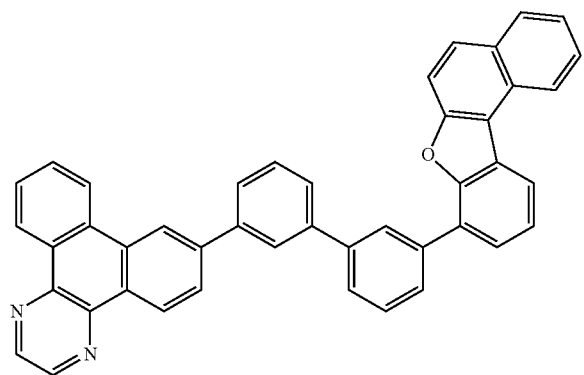

(115)

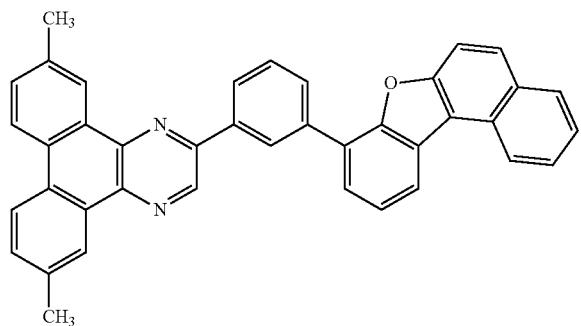

(114)

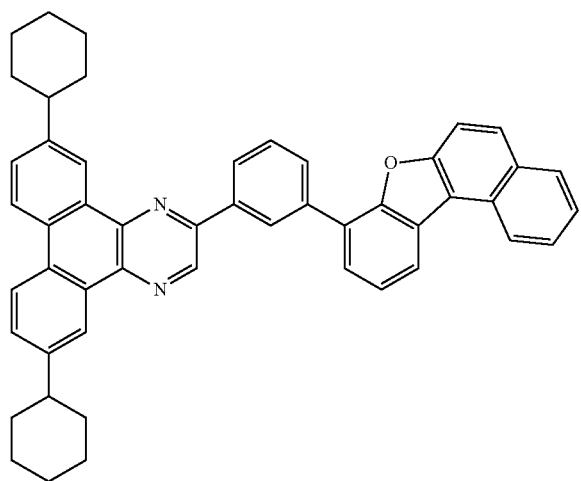
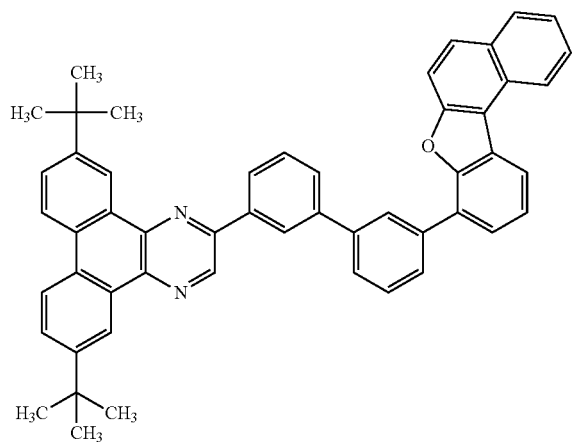

(116)

-continued

(117)

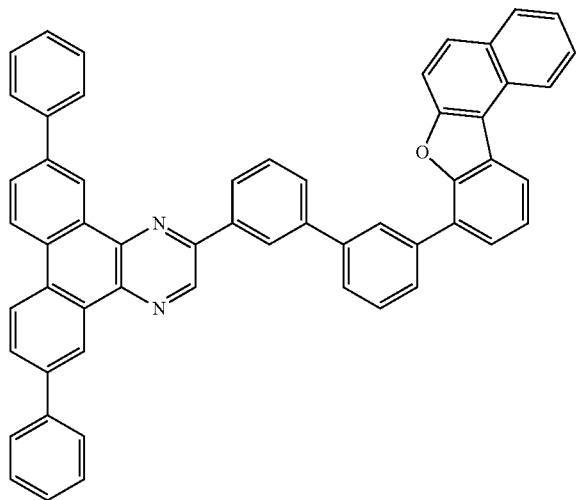

(118)

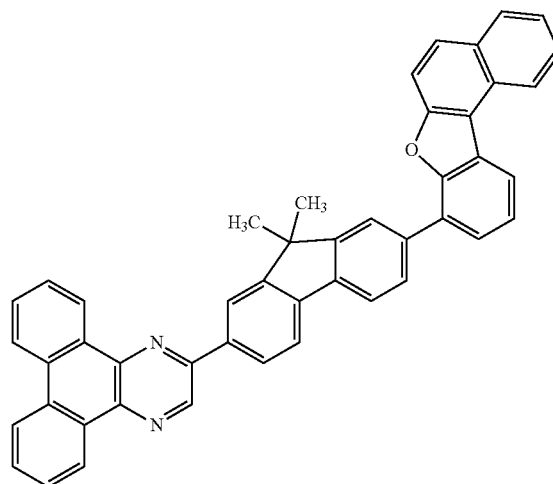

(119)

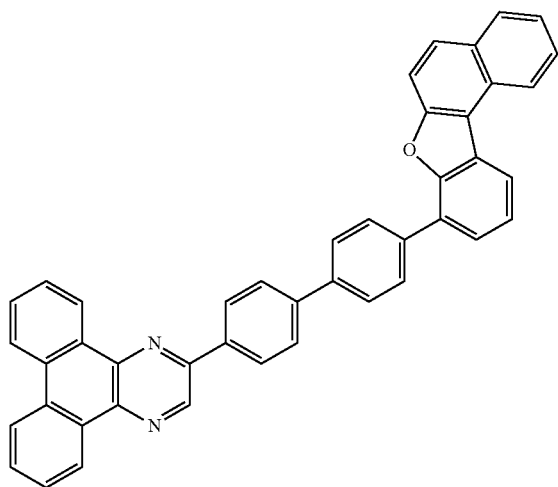

(120)

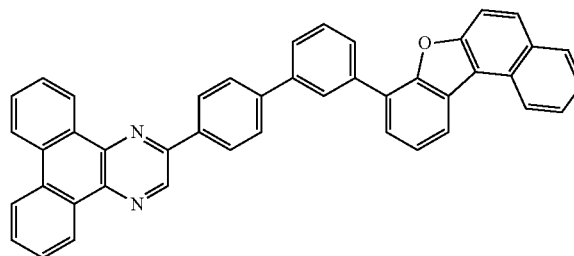

(121)

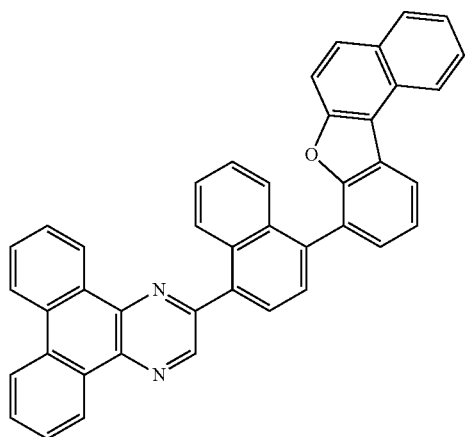

(122)

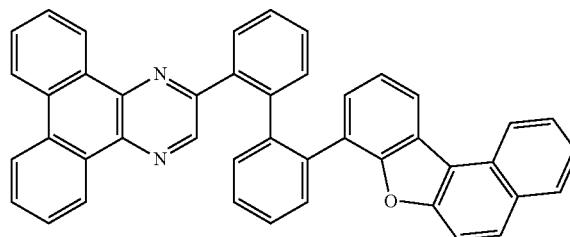

-continued

(123)

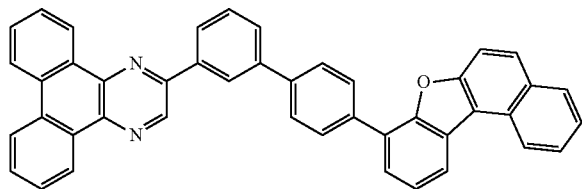

(124)

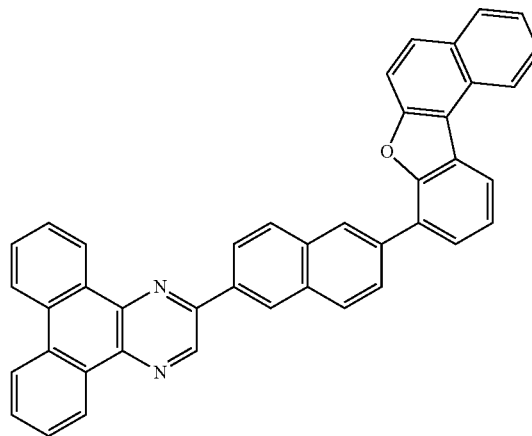

(125)

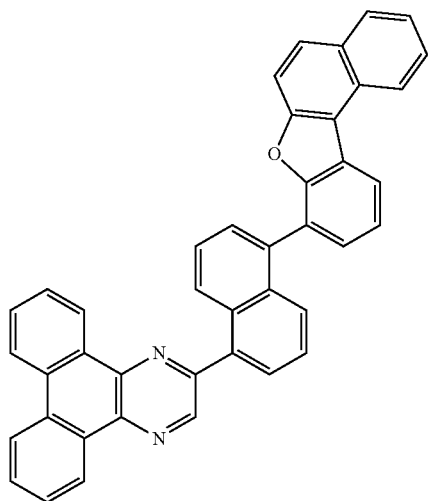

(126)

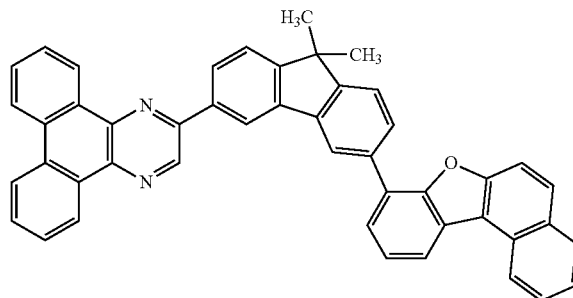

(127)

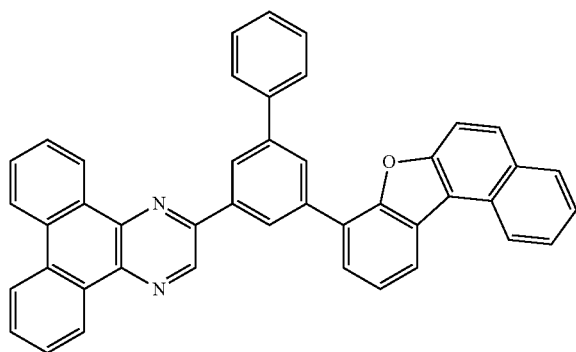

(128)

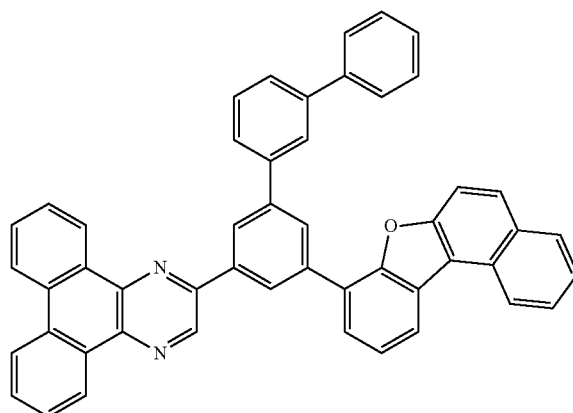

-continued

(129)

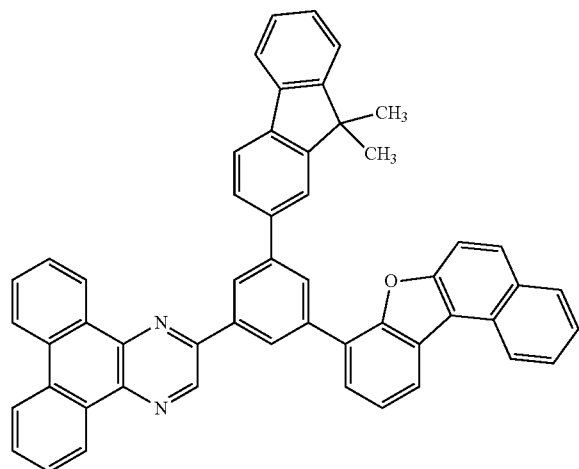

(130)

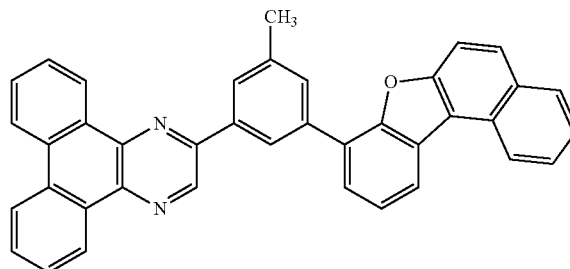

(131)

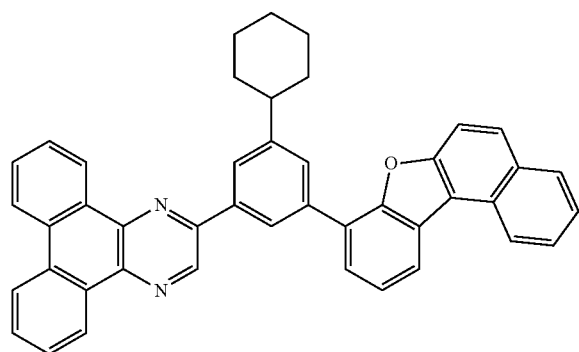

(132)

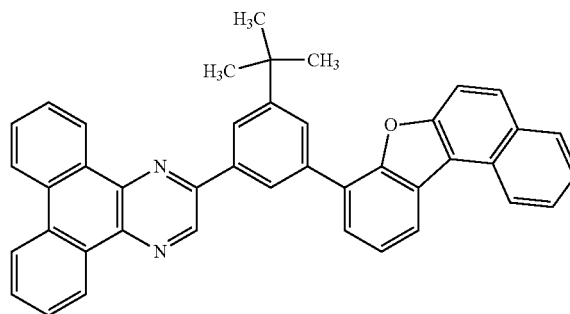

(133)

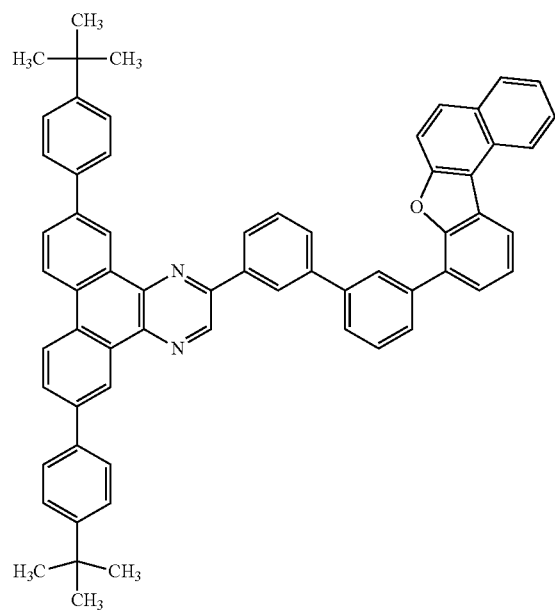

(134)

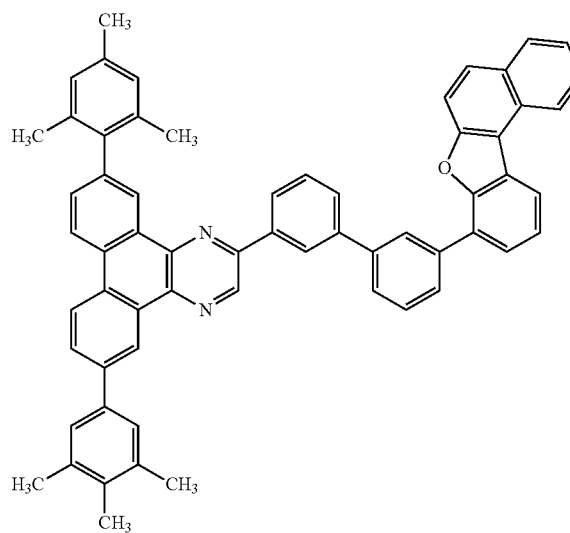

-continued

(135)

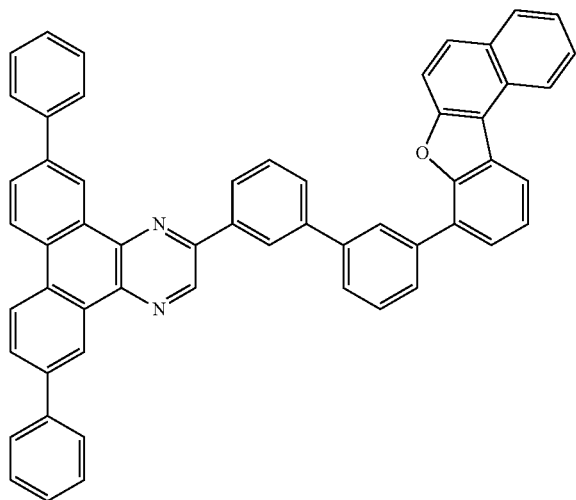

(136)

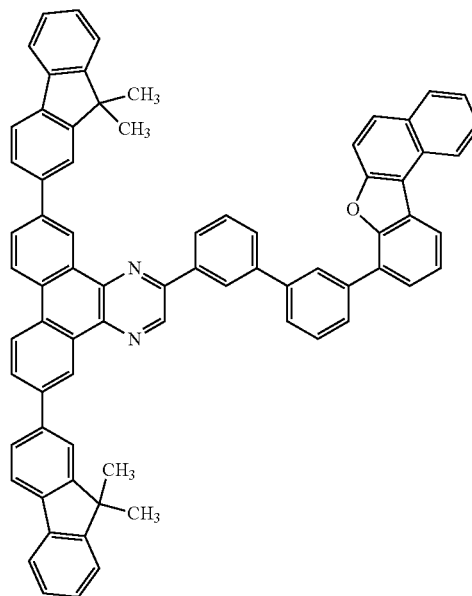

(137)

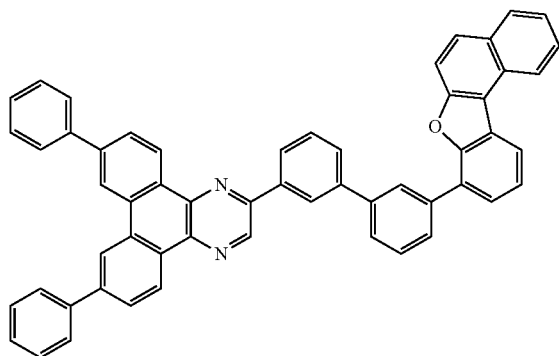

(138)

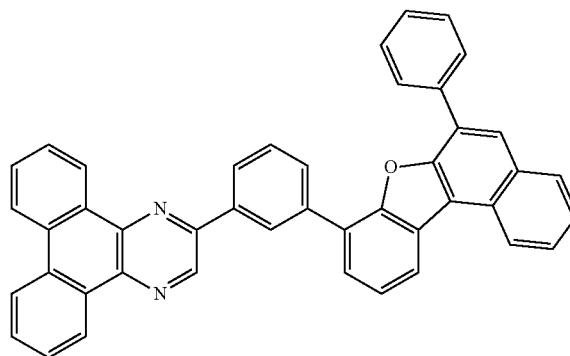

(138)

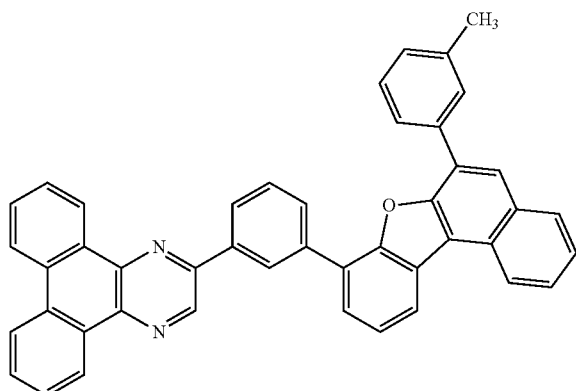

(140)

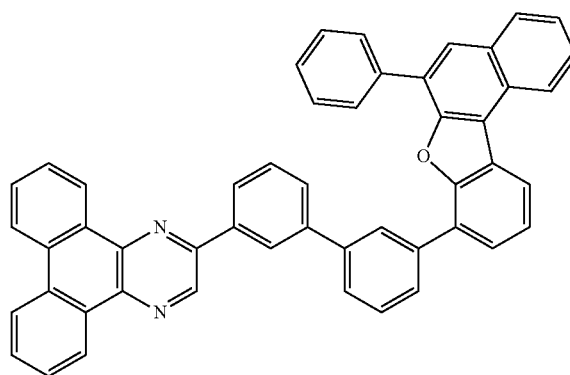

-continued

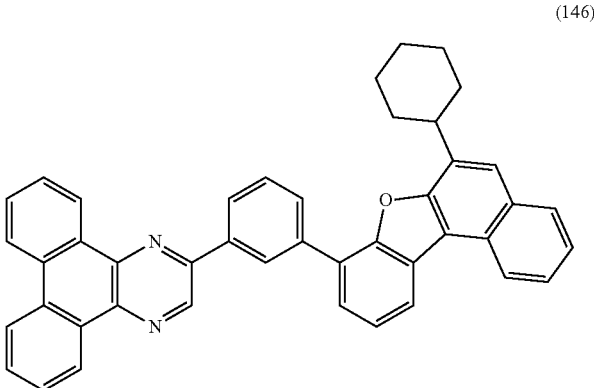
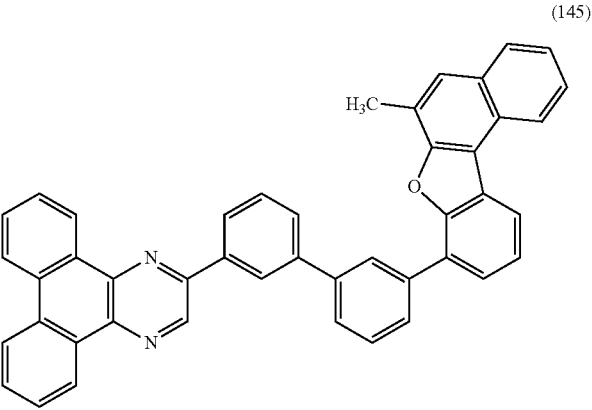
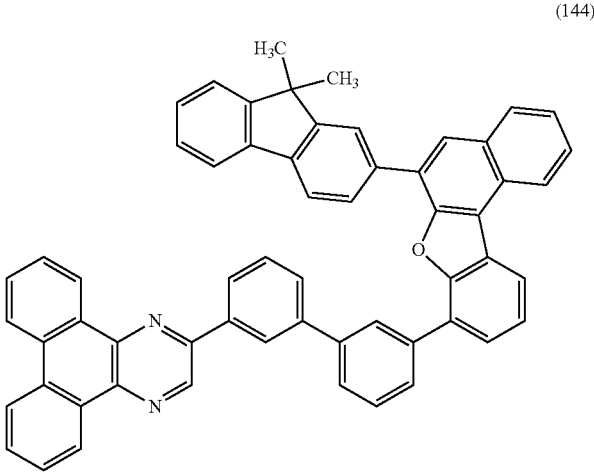
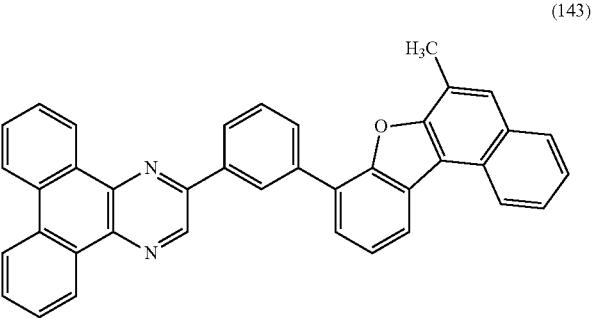
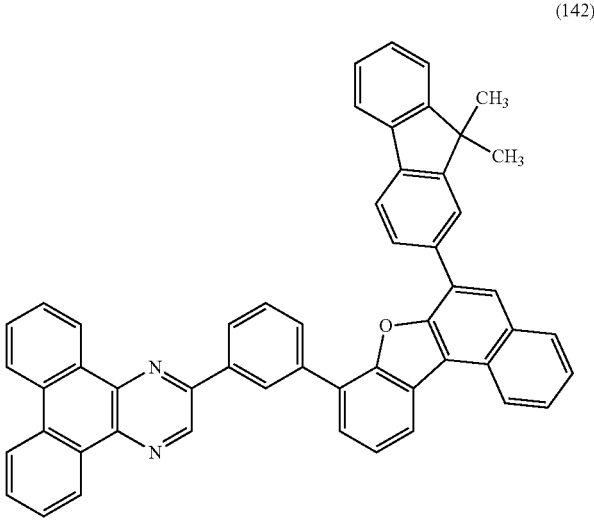
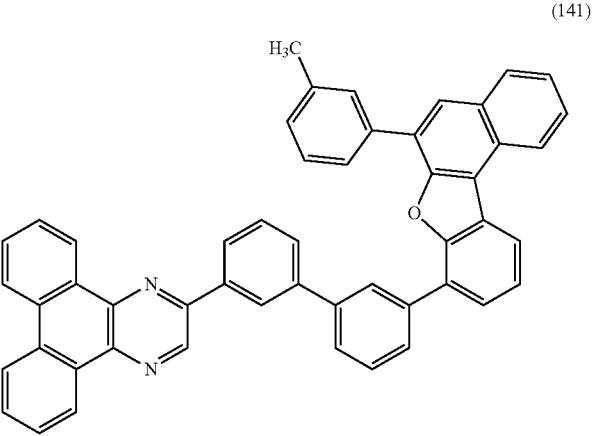

-continued

(147)

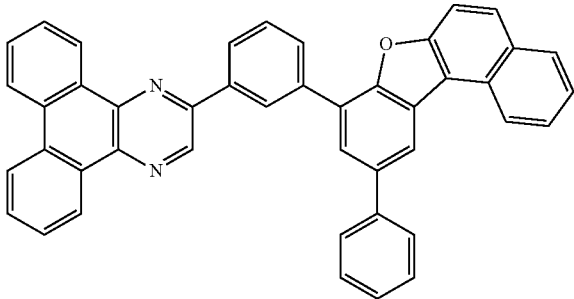

(148)

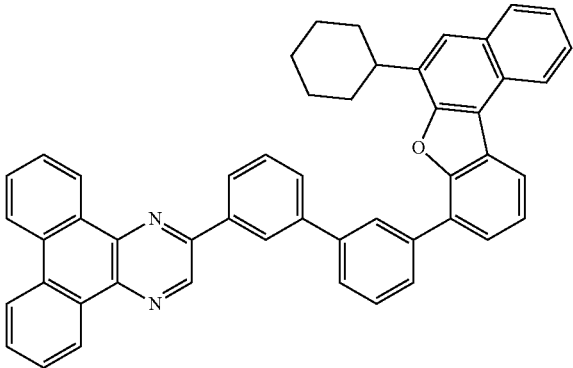

(149)

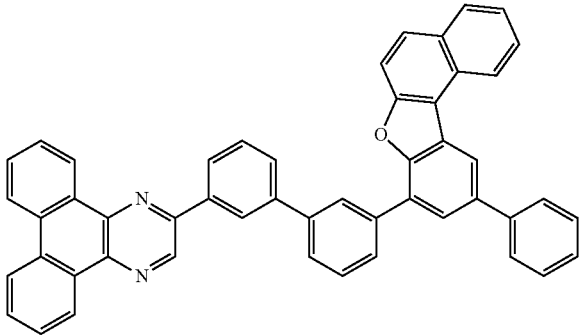

(150)

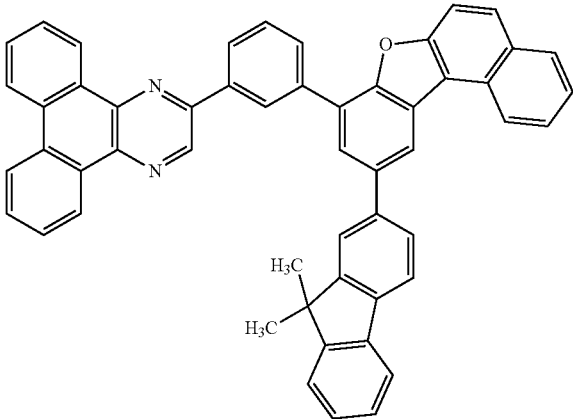

(151)

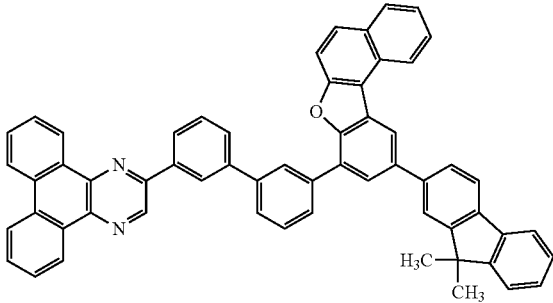

(152)

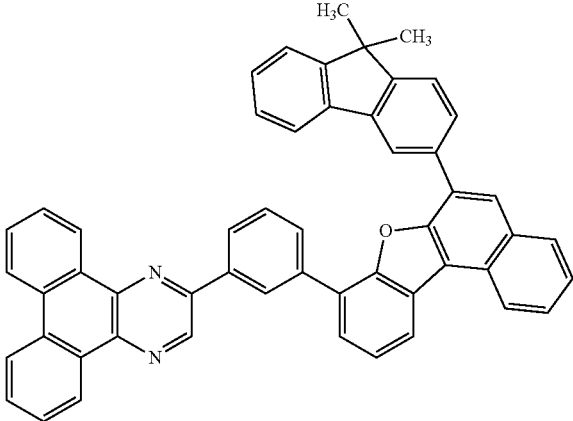

-continued

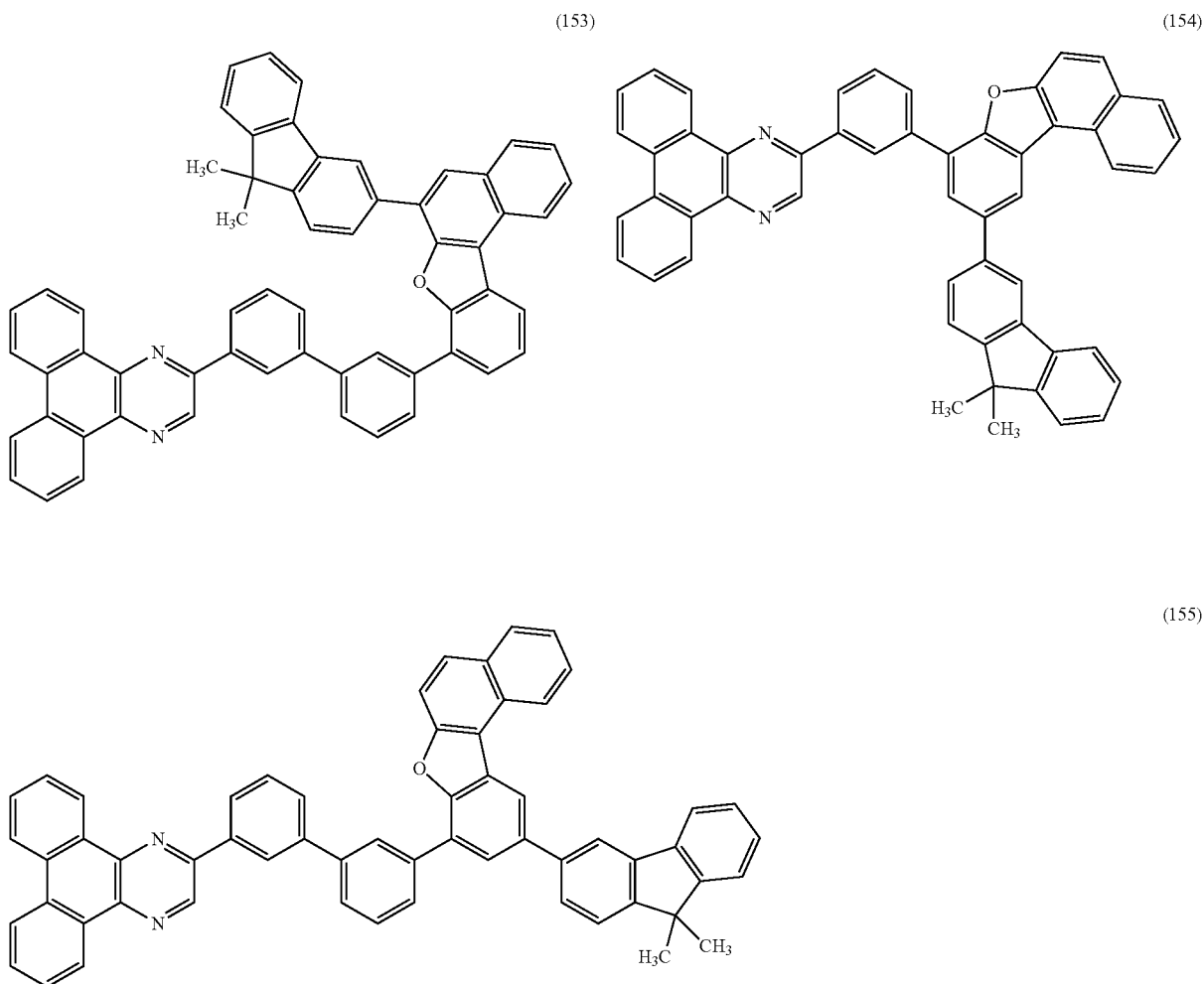

[0093] A variety of reactions can be applied to a method for synthesizing the heterocyclic compound of one embodiment of the present invention. As an example, a method for synthesizing the heterocyclic compound represented by General Formula (G1) in which R¹⁰ is the substituent represented by General formula (G1-1), i.e., a method for synthesizing the heterocyclic compound represented by General Formula (G2), is described below. Note that the methods for synthesizing the heterocyclic compound of one embodiment of the present invention are not limited to the synthesis methods below.

[0094] The heterocyclic compound represented by General Formula (G2) can be synthesized under Synthesis Scheme (A-1) below. That is, the heterocyclic compound represented by General Formula (G2) can be obtained by coupling of a benzo[b]naphtho[1,2-d]furan compound

(Compound 1) and a dibenzo[f,h]quinoxaline compound (Compound 2).

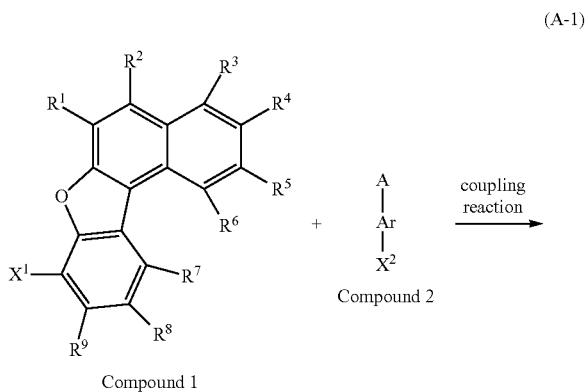

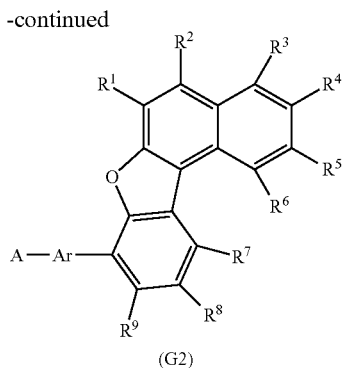

[0095] In Synthesis Scheme (A-1), A represents a substituted or unsubstituted dibenzo[f,h]quinoxalanyl group; Ar represents a substituted or unsubstituted arylene group having 6 to 25 carbon atoms; X¹ and X² separately represent any one of a halogen, a trifluoromethanesulfonyl group, a boronic acid group, an organoboron group, a halogenated magnesium group, an organotin group, and the like; and R¹ to R⁹ separately represent any one of hydrogen, an alkyl group having 1 to 6 carbon atoms, and a substituted or unsubstituted aryl group having 6 to 13 carbon atoms.

[0096] When a Suzuki-Miyaura coupling reaction using a palladium catalyst is performed under Synthesis Scheme (A-1), X¹ and X² separately represent any one of a halogen, a boronic acid group, an organoboron group, and a trifluoromethanesulfonyl group. It is preferable that the halogen be any one of iodine, bromine, and chlorine. In the reaction, a palladium compound such as bis(dibenzylideneacetone)palladium(0) or palladium(II) acetate and a ligand such as tri(*tert*-butyl)phosphine, tri(*n*-hexyl)phosphine, tricyclohexylphosphine, di(1-adamantyl)-*n*-butylphosphine, 2-dicyclohexylphosphino-2',6'-dimethoxybiphenyl, or tri(*ortho*-tolyl)phosphine can be used. In addition, in the reaction, an organic base such as sodium *tert*-butoxide, an inorganic base such as potassium carbonate, cesium carbonate, or sodium carbonate, or the like can be used. Furthermore, in the reaction, toluene, xylene, benzene, tetrahydrofuran, dioxane, ethanol, methanol, water, or the like can be used as a solvent. Reagents that can be used in the reaction are not limited thereto.

[0097] The reaction performed under Synthesis Scheme (A-1) is not limited to a Suzuki-Miyaura coupling reaction, and a Migita-Kosugi-Stille coupling reaction using an organotin compound, a Kumada-Tamao-Corriu coupling reaction using a Grignard reagent, a Negishi coupling reaction using an organozinc compound, a reaction using copper or a copper compound, or the like can also be employed.

[0098] By a method similar to the above, it is also possible to synthesize a heterocyclic compound in which the substituent represented by General Formula (G1-1) is bonded to the 9-position, the 10-position, or the 11-position of benzo[b]naphtho[1,2-d]furan (i.e., a heterocyclic compound represented by General Formula (G1) in which R⁷, R⁸, or R⁹ represents the substituent represented by General Formula (G1-1)).

[0099] Specifically, when R⁷, R⁸, or R⁹ of Compound 1 in Synthesis Scheme (A-1) represents any one of a halogen, a trifluoromethanesulfonyl group, a boronic acid group, an organoboron group, a halogenated magnesium group, an organotin group, and the like, by causing a coupling reaction

similar to that performed under Synthesis Scheme (A-1), it is possible to synthesize a heterocyclic compound in which the substituent represented by General Formula (G1-1) and including a dibenzo[f,h]quinoxaline skeleton is bonded to the 9-position, the 10-position, or the 11-position of benzo[b]naphtho[1,2-d]furan, i.e., the heterocyclic compound represented by General Formula (G1) in which R⁷, R⁸, or R⁹ represents the substituent represented by General Formula (G1-1).

[0100] In synthesis of the heterocyclic compound represented by General Formula (G2), Ar may be coupled at the 8-position of the benzo[b]naphtho[1,2-d]furan skeleton, and then, the resulting compound may be coupled with a dibenzo[f,h]quinoxaline skeleton.

[0101] Thus, the heterocyclic compound of this embodiment can be synthesized.

[0102] An organoboron compound in which boron is bonded to any one of the 7- to 10-positions of benzo[b]naphtho[1,2-d]furan and which is used in synthesis of the heterocyclic compound of one embodiment of the present invention is also one embodiment of the present invention.

[0103] One embodiment of the present invention is an organoboron compound represented by General Formula (G4).

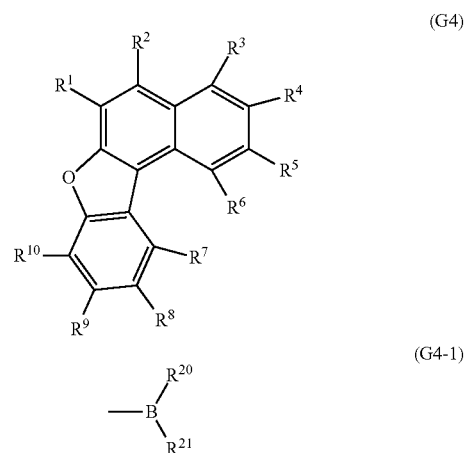

[0104] In the formula, R¹ to R⁶ separately represent any one of hydrogen, an alkyl group having 1 to 6 carbon atoms, a cycloalkyl group having 3 to 6 carbon atoms, and an aryl group having 6 to 13 carbon atoms; one of R⁷ to R¹⁰ represents a substituent represented by General Formula (G4-1); the others of R⁷ to R¹⁰ separately represent any one of hydrogen, an alkyl group having 1 to 6 carbon atoms, a cycloalkyl group having 3 to 6 carbon atoms, and an aryl group having 6 to 13 carbon atoms; and R²⁰ and R²¹ separately represent any one of a hydroxyl group and an alkoxy group having 1 to 6 carbon atoms and may be bonded to each other to form a ring. The aryl group and the alkoxy group are separately unsubstituted or substituted by any one of an alkyl group having 1 to 6 carbon atoms, a cycloalkyl group having 3 to 6 carbon atoms, and an aryl group having 6 to 13 carbon atoms.

[0105] Specific examples of the organoboron compound of one embodiment of the present invention include organoboron compounds represented by Structural Formulae (200) to (207). However, the present invention is not limited to

these structural formulae. Structural Formulae (201), (203), (205), and (207) illustrate specific examples of the case where R^{20} and R^{21} in General Formula (G4-1) each represent a substituted alkoxy group having 1 to 6 carbon atoms and the case where R^{20} and R^{21} are bonded to each other to form a ring.

(200)

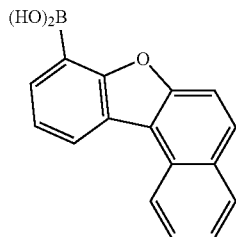

(201)

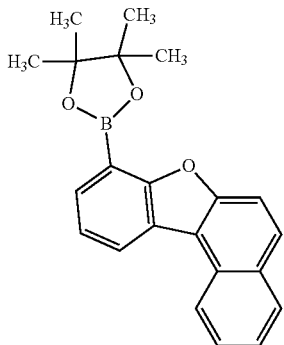

(202)

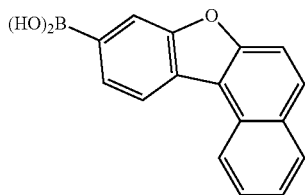

(203)

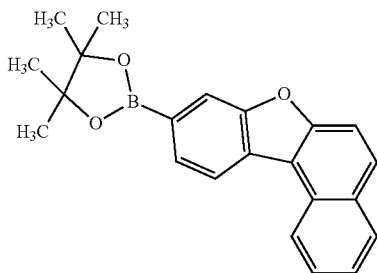

(204)

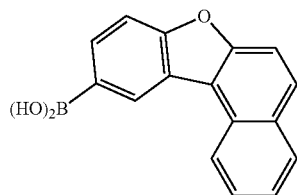

-continued

(205)

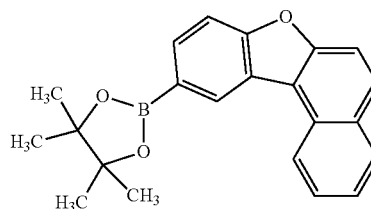

(206)

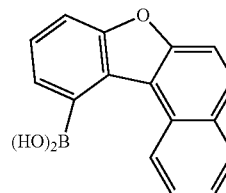

(207)

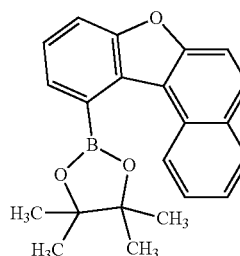

[0106] In a light-emitting element, the heterocyclic compound of this embodiment can be favorably used as a host material of a light-emitting layer, in which a light-emitting substance is dispersed, or a material of an electron-transport layer. By the use of the heterocyclic compound of this embodiment, a light-emitting element with a long lifetime can be provided.

[0107] This embodiment can be combined with any other embodiment as appropriate.

Embodiment 2

[0108] In this embodiment, light-emitting elements of embodiments of the present invention will be described with reference to FIGS. 1A to 1D.

[0109] A light-emitting element of one embodiment of the present invention has a layer containing the heterocyclic compound described in Embodiment 1 between a pair of electrodes.

[0110] The heterocyclic compound included in the light-emitting element of one embodiment of the present invention is sterically bulky and highly resistant to heat. Accordingly, the use of the heterocyclic compound enables a light-emitting element to have a long lifetime.

[0111] Furthermore, the heterocyclic compound can accept electrons and holes since the heterocyclic compound has a dibenzo[f,h]quinoxaline skeleton as an electron-transport skeleton and a benzo[b]naphtho[1,2-d]furan skeleton as a hole-transport skeleton. Accordingly, by the use of the heterocyclic compound as a host material of a light-emitting layer, electrons and holes recombine in the light-emitting layer and it is possible to inhibit a reduction in lifetime of the light-emitting element. That is, a preferred embodiment of the present invention is a light-emitting element including, between a pair of electrodes, a light-emitting layer contain-

ing a light-emitting substance (guest material) and the above heterocyclic compound serving as a host material in which the light-emitting substance is dispersed.

[0112] The light-emitting element of this embodiment includes a layer (EL layer) containing a light-emitting organic compound between a pair of electrodes (a first electrode and a second electrode). One of the first electrode and the second electrode functions as an anode, and the other functions as a cathode. In this embodiment, the EL layer contains the heterocyclic compound of one embodiment of the present invention which is described in Embodiment 1.

<<Structural Example of Light-Emitting Element>>

[0113] A light-emitting element illustrated in FIG. 1A includes an EL layer 203 between a first electrode 201 and a second electrode 205. In this embodiment, the first electrode 201 serves as an anode and the second electrode 205 serves as a cathode.

[0114] When a voltage higher than the threshold voltage of the light-emitting element is applied between the first electrode 201 and the second electrode 205, holes are injected from the first electrode 201 side to the EL layer 203 and electrons are injected from the second electrode 205 side to the EL layer 203. The injected electrons and holes recombine in the EL layer 203 and a light-emitting substance contained in the EL layer 203 emits light.

[0115] The EL layer 203 includes at least a light-emitting layer 303 containing a light-emitting substance.

[0116] Furthermore, when a plurality of light-emitting layers are provided in the EL layer and emission colors of the layers are made different, light emission of a desired color can be provided from the light-emitting element as a whole. For example, the emission colors of first and second light-emitting layers are complementary in a light-emitting element having the two light-emitting layers, so that the light-emitting element can be made to emit white light as a whole. Note that “complementary colors” refer to colors that can produce an achromatic color when mixed. In other words, when light components obtained from substances that emit light of complementary colors are mixed, white emission can be obtained. Furthermore, the same applies to a light-emitting element having three or more light-emitting layers.

[0117] In addition to the light-emitting layer, the EL layer 203 may further include a layer containing a substance with a high hole-injection property, a substance with a high hole-transport property, a substance with a high electron-transport property, a substance with a high electron-injection property, a substance with a bipolar property (a substance with a high electron-transport property and a high hole-transport property), or the like. Either a low molecular compound or a high molecular compound can be used for the EL layer 203, and an inorganic compound may be used.

[0118] A light-emitting element illustrated in FIG. 1B includes the EL layer 203 between the first electrode 201 and the second electrode 205, and in the EL layer 203, a hole-injection layer 301, a hole-transport layer 302, the light-emitting layer 303, an electron-transport layer 304, and an electron-injection layer 305 are stacked in that order from the first electrode 201 side.

[0119] The heterocyclic compound of one embodiment of the present invention is preferably used for the light-emitting layer 303 or the electron-transport layer 304. In this embodiment, an example is described in which the heterocyclic

compound of one embodiment of the present invention is used as the host material in the light-emitting layer 303.

[0120] As in light-emitting elements illustrated in FIGS. 1C and 1D, a plurality of EL layers may be stacked between the first electrode 201 and the second electrode 205. In this case, an intermediate layer 207 is preferably provided between the stacked EL layers. The intermediate layer 207 includes at least a charge-generation region.

[0121] For example, the light-emitting element illustrated in FIG. 1C includes the intermediate layer 207 between a first EL layer 203a and a second EL layer 203b. The light-emitting element illustrated in FIG. 1D includes n EL layers (n is a natural number of 2 or more), and the intermediate layers 207 between the EL layers.

[0122] The behaviors of electrons and holes in the intermediate layer 207 provided between the EL layer 203(m) and the EL layer 203(m+1) will be described. When a voltage higher than the threshold voltage of the light-emitting element is applied between the first electrode 201 and the second electrode 205, holes and electrons are generated in the intermediate layer 207, and the holes move into the EL layer 203(m+1) provided on the second electrode 205 side and the electrons move into the EL layer 203(m) provided on the first electrode 201 side. The holes injected into the EL layer 203(m+1) recombine with electrons injected from the second electrode 205 side, so that a light-emitting substance contained in the EL layer 203(m+1) emits light. Furthermore, the electrons injected into the EL layer 203(m) recombine with holes injected from the first electrode 201 side, so that a light-emitting substance contained in the EL layer 203(m) emits light. Thus, the holes and electrons generated in the intermediate layer 207 cause light emission in different EL layers.

[0123] Note that the EL layers can be provided in contact with each other with no intermediate layer interposed therebetween when these EL layers allow the same structure as the intermediate layer to be formed therebetween. For example, when the charge-generation region is formed over one surface of an EL layer, another EL layer can be provided in contact with the surface.

[0124] Furthermore, when emission colors of the EL layers are made different, light emission of a desired color can be provided from the light-emitting element as a whole. For example, the emission colors of first and second EL layers are complementary in a light-emitting element having the two EL layers, so that the light-emitting element can be made to emit white light as a whole. The same applies to a light-emitting element having three or more EL layers.

<<Materials of Light-Emitting Element>>

[0125] Examples of materials which can be used for each layer will be given below. Note that each layer is not limited to a single layer, and may be a stack of two or more layers.

<Anode>

[0126] The electrode serving as the anode (the first electrode 201 in this embodiment) can be formed using one or more kinds of conductive metals, conductive alloys, conductive compounds, and the like. In particular, it is preferable to use a material with a high work function (4.0 eV or more). The examples include indium tin oxide (ITO), indium tin oxide containing silicon or silicon oxide, indium zinc oxide, indium oxide containing tungsten oxide and zinc

oxide, graphene, gold, platinum, nickel, tungsten, chromium, molybdenum, iron, cobalt, copper, palladium, titanium, and a nitride of a metal material (e.g., titanium nitride).

[0127] When the anode is in contact with the charge-generation region, any of a variety of conductive materials can be used regardless of their work functions; for example, aluminum, silver, an alloy containing aluminum, or the like can be used.

<Cathode>

[0128] The electrode serving as the cathode (the second electrode 205 in this embodiment) can be formed using one or more kinds of conductive metals, conductive alloys, conductive compounds, and the like. In particular, it is preferable to use a material with a low work function (3.8 eV or less). The examples include aluminum, silver, an element belonging to Group 1 or 2 of the periodic table (e.g., an alkali metal such as lithium or cesium, an alkaline earth metal such as calcium or strontium, or magnesium), an alloy containing any of these elements (e.g., Mg—Ag or Al—Li), a rare earth metal such as europium or ytterbium, and an alloy containing any of these rare earth metals.

[0129] Note that when the cathode is in contact with the charge-generation region, any of a variety of conductive materials can be used regardless of its work function. For example, ITO or indium tin oxide containing silicon or silicon oxide can be used.

[0130] The electrodes may be formed separately by a vacuum evaporation method or a sputtering method. Alternatively, when a silver paste or the like is used, a coating method or an inkjet method may be used.

<Light-Emitting Layer>

[0131] The light-emitting layer 303 contains a light-emitting substance. In an example described in this embodiment, the light-emitting layer 303 contains a guest material and a host material in which the guest material is dispersed and the heterocyclic compound of one embodiment of the present invention is used as the host material. The heterocyclic compound of one embodiment of the present invention can be favorably used as a host material in a light-emitting layer when a light-emitting substance is a phosphorescent compound emitting light in a wavelength range from red to green or a fluorescent compound.

[0132] When the light-emitting layer has the structure in which the guest material is dispersed in the host material, the crystallization of the light-emitting layer can be inhibited. Furthermore, it is possible to inhibit concentration quenching due to high concentration of the guest material; thus, the light-emitting element can have higher emission efficiency.

[0133] In addition to the guest material and the host material, the light-emitting layer may contain another compound. Furthermore, in addition to the light-emitting layer containing the heterocyclic compound of one embodiment of the present invention, the light-emitting element of one embodiment of the present invention may include another light-emitting layer. In that case, a fluorescent compound, a phosphorescent compound, or a substance emitting thermally activated delayed fluorescence can be used as the light-emitting substance, and a compound to be described

below which easily accepts electrons or a compound to be described below which easily accepts holes can be used as the host material.

[0134] Note that it is preferable that the T_1 level of the host material (or a material other than the guest material in the light-emitting layer) be higher than the T_1 level of the guest material. This is because, when the T_1 level of the host material is lower than that of the guest material, the triplet excitation energy of the guest material, which is to contribute to light emission, is quenched by the host material and accordingly the emission efficiency is reduced.

[0135] Here, for improvement in efficiency of energy transfer from a host material to a guest material, Förster mechanism (dipole-dipole interaction) and Dexter mechanism (electron exchange interaction), which are known as mechanisms of energy transfer between molecules, are considered. According to the mechanisms, it is preferable that an emission spectrum of a host material (fluorescence spectrum in energy transfer from a singlet excited state, phosphorescence spectrum in energy transfer from a triplet excited state) have a large overlap with an absorption spectrum of a guest material (specifically, spectrum in an absorption band on the longest wavelength (lowest energy) side).

[0136] However, in general, it is difficult to obtain an overlap between a fluorescence spectrum of a host material and an absorption spectrum in an absorption band on the longest wavelength (lowest energy) side of a guest material. The reason for this is as follows: if the fluorescence spectrum of the host material overlaps with the absorption spectrum in the absorption band on the longest wavelength (lowest energy) side of the guest material, because the phosphorescence spectrum of the host material is located on the longer wavelength (lower energy) side than the fluorescence spectrum, the T_1 level of the host material becomes lower than the T_1 level of the phosphorescent compound and the above-described problem of quenching occurs; yet, when the host material is designed in such a manner that the T_1 level of the host material is higher than the T_1 level of the phosphorescent compound to avoid the problem of quenching, the fluorescence spectrum of the host material is shifted to the shorter wavelength (higher energy) side, and thus the fluorescence spectrum does not have any overlap with the absorption spectrum in the absorption band on the longest wavelength (lowest energy) side of the guest material. For this reason, in general, it is difficult to obtain an overlap between a fluorescence spectrum of a host material and an absorption spectrum in an absorption band on the longest wavelength (lowest energy) side of a guest material so as to maximize energy transfer from a singlet excited state of a host material.

[0137] Thus, it is preferable that in a light-emitting layer of a light-emitting element which uses a phosphorescent compound as a guest material, a third substance be contained in addition to the phosphorescent compound and the host material (which are respectively regarded as a first substance and a second substance contained in the light-emitting layer), and the host material forms an exciplex (also referred to as excited complex) in combination with the third substance. In that case, the host material and the third substance form an exciplex at the time of recombination of carriers (electrons and holes) in the light-emitting layer. Thus, in the light-emitting layer, fluorescence spectra of the host material and the third substance are converted into an emission

spectrum of the exciplex which is located on a longer wavelength side. Moreover, when the host material and the third substance are selected such that the emission spectrum of the exciplex has a large overlap with the absorption spectrum of the guest material, energy transfer from a singlet excited state can be maximized. Note that also in the case of a triplet excited state, energy transfer from the exciplex, not the host material, is considered to occur. In one embodiment of the present invention to which such a structure is applied, energy transfer efficiency can be improved owing to energy transfer utilizing an overlap between an emission spectrum of an exciplex and an absorption spectrum of a phosphorescent compound; accordingly, a light-emitting element with high external quantum efficiency can be provided.

[0138] As the guest material, a phosphorescent compound to be described below can be used. Although any combination of the host material and the third substance can be used as long as an exciplex is formed, a compound which easily accepts electrons (a compound having an electron-trapping property) and a compound which easily accepts holes (a compound having a hole-trapping property) are preferably combined. The heterocyclic compound of one embodiment of the present invention can be used as a compound having an electron-trapping property.

[0139] Thus, the light-emitting element of one embodiment of the present invention includes, between a pair of electrodes, a light-emitting layer containing a phosphorescent compound emitting light in a wavelength range from red to green, the heterocyclic compound of one embodiment of the present invention, and a compound which easily accepts holes.

[0140] Examples of a compound which easily accepts holes and which can be used as the host material or the third substance are a n-electron rich heteroaromatic compound (e.g., a carbazole derivative or an indole derivative) and an aromatic amine compound.

[0141] Specifically, the following examples can be given: N-(1,1'-biphenyl-4-yl)-N-[4-(9-phenyl-9H-carbazol-3-yl)phenyl]-9,9-dimethyl-9H-fluorene-2-amine (abbreviation: PCBBIF), 4-phenyl-4'-(9-phenyl-9H-carbazol-3-yl)triphenylamine (abbreviation: PCBA1BP), 4,4'-di(1-naphthyl)-4''-(9-phenyl-9H-carbazol-3-yl)triphenylamine (abbreviation: PCBNBB), 3-[N-(1-naphthyl)-N-(9-phenylcarbazol-3-yl)amino]-9-phenylcarbazole (abbreviation: PCzPCN1), 4,4',4''-tris[N-(1-naphthyl)-N-phenylamino]triphenylamine (abbreviation: 1'-TNATA), 2,7-bis[N-(4-diphenylaminophenyl)-N-phenylamino]spiro-9,9'-bifluorene (abbreviation: DPA2SF), N,N'-bis(9-phenylcarbazol-3-yl)-N,N'-diphenylbenzene-1,3-diamine (abbreviation: PCA2B), N-(9,9-dimethyl-2-diphenylamino-9H-fluorene-7-yl)diphenylamine (abbreviation: DPNF), N,N,N'-triphenyl-N,N,N'-tris(9-phenylcarbazol-3-yl)benzene-1,3,5-triamine (abbreviation: PCA3B), 2-[N-(9-phenylcarbazol-3-yl)-N-phenylamino]spiro-9,9'-bifluorene (abbreviation: PCASF), 2-[N-(4-diphenylaminophenyl)-N-phenylamino]spiro-9,9'-bifluorene (abbreviation: DPASF), N,N'-bis[4-(carbazol-9-yl)phenyl]-N,N'-diphenyl-9,9-dimethylfluorene-2,7-diamine (abbreviation: YGA2F), N,N-bis(3-methylphenyl)-N,N'-diphenyl-[1,1'-biphenyl]-4,4'-diamine (abbreviation: TPD), 4,4'-bis[N-(4-diphenylaminophenyl)-N-phenylamino]biphenyl (abbreviation: DPAB), N-(9,9-dimethyl-9H-fluorene-2-yl)-N-{9,9-dimethyl-2-[N-phenyl-N'-(9,9-dimethyl-9H-fluorene-2-yl)amino]-9H-fluorene-7-yl}phenylamine (abbreviation: DFLADFL), 3-[N-(9-phenylcarbazol-3-yl)-N-phenylamino]-9-phenylcarbazole (abbreviation: PCzPCA1), 3,6-bis[N-(9-phenylcarbazol-3-yl)-N-phenylamino]-9-phenylcarbazole (abbreviation: PCzPCA2), 3-[N-(4-diphenylaminophenyl)-N-phenylamino]-9-phenylcarbazole (abbreviation: PCzDPA1), 3,6-bis[N-(4-diphenylaminophenyl)-N-phenylamino]-9-phenylcarbazole (abbreviation: PCzDPA2), 4,4'-bis(N-{4-[N-(3-methylphenyl)-N-phenylamino]phenyl}-N-phenylamino)biphenyl (abbreviation: DNTPD), 3,6-bis[N-(4-diphenylaminophenyl)-N-(1-naphthyl)amino]-9-phenylcarbazole (abbreviation: PCzTPN2), and the like.

[0142] The following examples can also be given: aromatic amine compounds such as 4,4'-bis[N-(1-naphthyl)-N-phenylamino]biphenyl (abbreviation: NPB or α -NPD), 4,4',4''-tris(N,N-diphenylamino)triphenylamine (abbreviation: TDATA), 4,4',4''-tris[N-(3-methylphenyl)-N-phenylamino]triphenylamine (abbreviation: MTDATA), 4,4'-bis[N-(spiro-9,9'-bifluorene-2-yl)-N-phenylamino]biphenyl (abbreviation: BSPB), 4,4',4''-tris(N-carbazolyl)triphenylamine (abbreviation: TCTA), 4-phenyl-4'-(9-phenylfluorene-9-yl)triphenylamine (abbreviation: BPAFLP), and 4,4'-bis[N-(9,9-dimethylfluorene-2-yl)-N-phenylamino]biphenyl (abbreviation: DFLDPBi); and carbazole derivatives such as 4,4'-di(N-carbazolyl)biphenyl (abbreviation: CBP), 9-[4-(10-phenyl-9-anthracenyl)phenyl]-9H-carbazole (abbreviation: CzPA), and 9-phenyl-3-[4-(10-phenyl-9-anthryl)phenyl]-9H-carbazole (abbreviation: PCzPA). In addition, high molecular compounds such as poly(N-vinylcarbazole) (abbreviation: PVK), poly(4-vinyltriphenylamine) (abbreviation: PVTPA), poly[N-(4-{N-[4-(4-diphenylamino)phenyl]phenyl-N-phenylamino}phenyl)methacrylamide] (abbreviation: PTPDMA), and poly[N,N'-bis(4-butylphenyl)-N,N-bis(phenyl)benzidine] (abbreviation: Poly-TPD) can be given.

[0143] Examples of the compound which easily accepts electrons and which can be used as the host material or the third substance include the heterocyclic compound of one embodiment of the present invention, a π -electron deficient heteroaromatic compound such as a nitrogen-containing heteroaromatic compound, a metal complex having a quinoline skeleton or a benzoquinoline skeleton, and a metal complex having an oxazole-based ligand or a thiazole-based ligand.

[0144] Specific examples include the following: metal complexes such as bis(10-hydroxybenzo[h]quinolinato)beryllium (abbreviation: BeBq₂), bis(2-methyl-8-quinolinolato)(4-phenylphenolato)aluminum (abbreviation: BA1q), bis(8-quinolinolato)zinc(II) (abbreviation: Znq), bis[2-(2-hydroxyphenyl)benzoxazolato]zinc (abbreviation: Zn(BOX)₂), and bis[2-(2-hydroxyphenyl)benzothiazolato]zinc (abbreviation: Zn(BTZ)₂); heterocyclic compounds having polyazole skeletons, such as 2-(4-biphenyl)-5-(4-tert-butylphenyl)-1,3,4-oxadiazole (abbreviation: PBD), 3-(4-biphenyl)-4-phenyl-5-(4-tert-butylphenyl)-1,2,4-triazole (abbreviation: TAZ), 1,3-bis[5-(p-tert-butylphenyl)-1,3,4-oxadiazol-2-yl]benzene (abbreviation: OXD-7), 9-[4-(5-phenyl-1,3,4-oxadiazol-2-yl)phenyl]-9H-carbazole (abbreviation: CO11), 2,2',2''-(1,3,5-benzenetriyl)tris(1-phenyl-1H-benzimidazole) (abbreviation: TPBI), and 2-[3-(dibenzothiofen-4-yl)phenyl]-1-phenyl-1H-benzimidazole (abbreviation: mDBTBIm-II); heterocyclic compounds having quinoxaline skeletons or dibenzoquinoxaline skeletons, such as 2-[3-(dibenzothiofen-4-yl)phenyl]dibenzof[h]quinoxaline (abbreviation: 2mDBTPDBq-II), 2-[3'-(dibenzothiofen-4-yl)phenyl]dibenzof[h]quinoxaline (abbreviation: 2mDBTPDBq-I), and the like.

ioiphen-4-yl)biphenyl-3-yl]dibenzo[f,h]quinoxaline (abbreviation: 2mDBTBPDBq-II), 2-[4-(3,6-diphenyl-9H-carbazol-9-yl)phenyl]dibenzo[f,h]quinoxaline (abbreviation: 2CzPDBq-III), 7-[3-(dibenzothiophen-4-yl)phenyl]dibenzo[f,h]quinoxaline (abbreviation: 7mDBTBPDBq-II), 6-[3-(dibenzothiophen-4-yl)phenyl]dibenzo[f,h]quinoxaline (abbreviation: 6mDBTBPDBq-II), and 2-[3'-(9H-carbazol-9-yl)biphenyl-3-yl]dibenzo[1h]quinoxaline (abbreviation: 2mCzBPDBq); heterocyclic compounds having diazine skeletons (pyrimidine skeletons or pyrazine skeletons), such as 4,6-bis[3-(phenanthren-9-yl)phenyl]pyrimidine (abbreviation: 4,6mPnP2Pm), 4,6-bis[3-(9H-carbazol-9-yl)phenyl]pyrimidine (abbreviation: 4,6mCzP2Pm), and 4,6-bis[3-(4-dibenzothiophenyl)phenyl]pyrimidine (abbreviation: 4,6mDBTBP2Pm-II); heterocyclic compounds having pyridine skeletons, such as 3,5-bis[3-(9H-carbazol-9-yl)phenyl]pyridine (abbreviation: 3,5DCzPPy), 1,3,5-tri[3-(3-pyridyl)phenyl]benzene (abbreviation: TmPyPB), and 3,3',5,5'-tetra[(m-pyridyl)-phen-3-yl]biphenyl (abbreviation: BP4mPy). Among the above materials, heterocyclic compounds having quinoxaline skeletons or dibenzoquinoxaline skeletons, heterocyclic compounds having diazine skeletons, and heterocyclic compounds having pyridine skeletons are preferable because of their high reliability.

[0145] The following examples can also be given: metal complexes having quinoline skeletons or benzoquinoline skeletons, such as tris(8-quinolinolato)aluminum (abbreviation: Alq) and tris(4-methyl-8-quinolinolato)aluminum (abbreviation: Almq₃); and heteroaromatic compounds such as bathophenanthroline (abbreviation: BPhen), bathocuproine (abbreviation: BCP), 3-(4-tert-butylphenyl)-4-(4-ethylphenyl)-5-(4-biphenyl)-1,2,4-triazole (abbreviation: p-Et-TAZ), and 4,4'-bis(5-methylbenzoxazol-2-yl)stilbene (abbreviation: BzOs). In addition, high molecular compounds such as poly(2,5-pyridinediyl) (abbreviation: PPy), poly[(9,9-dihexylfluorene-2,7-diyl)-co-(pyridine-3,5-diyl)] (abbreviation: PF-Py), and poly[(9,9-dioctylfluorene-2,7-diyl)-co-(2,2'-bipyridine-6,6'-diyl)] (abbreviation: PF-BPy) can also be given.

[0146] The materials which can be used as the host material or the third substance are not limited to the above materials as long as the material used as the host material forms an exciplex in combination with the material used as the third substance, an emission spectrum of the exciplex overlaps with an absorption spectrum of the guest material, and a peak of the emission spectrum of the exciplex is located on a longer wavelength side than a peak of the absorption spectrum of the guest material.

[0147] Note that when a compound which easily accepts electrons and a compound which easily accepts holes are used for the host material and the third substance, carrier balance can be controlled by the mixture ratio of the compounds. Specifically, the ratio of the host material to the third substance is preferably from 1:9 to 9:1.

[0148] Furthermore, the exciplex may be formed at the interface between two layers. For example, when a layer containing the compound which easily accepts electrons and a layer containing the compound which easily accepts holes are stacked, the exciplex is formed in the vicinity of the interface thereof. These two layers may be used as the light-emitting layer in the light-emitting element of one embodiment of the present invention. In that case, the phosphorescent compound may be added to the vicinity of

the interface. The phosphorescent compound may be added to one of the two layers or both.

<<Guest Material>>

[0149] Examples of fluorescent compounds that can be used for the light-emitting layer **303** are given. Examples of materials that emit blue light are as follows: N,N-bis(3-methylphenyl)-N,N-bis[3-(9-phenyl-9H-fluoren-9-yl)phenyl]pyrene-1,6-diamine (abbreviation: 1,6mMemFLPA-Pm), N,N-bis(dibenzofuran-4-yl)-N,N-diphenylpyrene-1,6-diamine (abbreviation: 1,6FrAPm-II), N,N-bis[4-(9H-carbazol-9-yl)phenyl]-N,N-diphenylstilbene-4,4'-diamine (abbreviation: YGA2S), 4-(9H-carbazol-9-yl)-4'-(10-phenyl-9-anthryl)triphenylamine (abbreviation: YGAPA), and 4-(10-phenyl-9-anthryl)-4'-(9-phenyl-9H-carbazol-3-yl)triphenylamine (abbreviation: PCBAPA). Examples of materials that emit green light are as follows: N-(9,10-diphenyl-2-anthryl)-N,9-diphenyl-9H-carbazol-3-amine (abbreviation: 2PCAPA), N-[9,10-bis(1,1'-biphenyl-2-yl)-2-anthryl]-N,9-diphenyl-9H-carbazol-3-amine (abbreviation: 2PCABPhA), N-(9,10-diphenyl-2-anthryl)-N,N,N-triphenyl-1,4-phenylenediamine (abbreviation: 2DPAPA), N-[9,10-bis(1,1'-biphenyl-2-yl)-2-anthryl]-N,N,N-triphenyl-1,4-phenylenediamine (abbreviation: 2DPABPhA), 9,10-bis(1,1'-biphenyl-2-yl)-N-[4-(9H-carbazol-9-yl)phenyl]-N-phenylanthracen-2-amine (abbreviation: 2YGABPhA), and N,N,9-triphenylanthracen-9-amine (abbreviation: DPhAPhA). Examples of materials that emit yellow light are as follows: rubrene and 5,12-bis(1,1'-biphenyl-4-yl)-6,11-diphenyltetracene (abbreviation: BPT). Examples of materials that emit red light are as follows: N,N,N,N-tetrakis(4-methylphenyl)tetracene-5,11-diamine (abbreviation: p-mPhTD) and 7,14-diphenyl-N,N,N,N-tetrakis(4-methylphenyl)acenaphtho[1,2- α]fluoranthene-3,10-diamine (abbreviation: p-mPhAFD).

[0150] Examples of phosphorescent compounds that can be used for the light-emitting layer **303** are given. For example, a phosphorescent compound having an emission peak at 440 nm to 520 nm is given, examples of which include organometallic iridium complexes having 4H-triazole skeletons, such as tris {2-[5-(2-methylphenyl)-4-(2,6-dimethylphenyl)-4H-1,2,4-triazol-3-yl-KN2]phenyl-K C} iridium(III) (abbreviation: [Ir(mpptz-dmp)₃]), tris(5-methyl-3,4-diphenyl-4H-1,2,4-triazolato)iridium(III) (abbreviation: [Ir(Mptz)₃]), and tris[4-(3-biphenyl)-5-isopropyl-3-phenyl-4H-1,2,4-triazolato]iridium(III) (abbreviation: [Ir(iPrptz-3b)₃]); organometallic iridium complexes having 1H-triazole skeletons, such as tris[3-methyl-1-(2-methylphenyl)-5-phenyl-1H-1,2,4-triazolato]iridium(III) (abbreviation: [Ir(Mptz-mp)₃]) and tris(1-methyl-5-phenyl-3-propyl-1H-1,2,4-triazolato)iridium(III) (abbreviation: [Ir(Prptz1-Me)₃]); organometallic iridium complexes having imidazole skeletons, such as fac-tris[1-(2,6-diisopropylphenyl)-2-phenyl-1H-imidazole]iridium(III) (abbreviation: [Ir(iPrpm)₃]) and tris[3-(2,6-dimethylphenyl)-7-methylimidazo[1,2-f]phenanthridinato]iridium(III) (abbreviation: [Ir(dmpimpt-Me)₃]); and organometallic iridium complexes in which a phenylpyridine derivative having an electron-withdrawing group is a ligand, such as bis[2-(4',6'-difluorophenyl)pyridinato-N,C²]iridium(III) tetrakis(1-pyrazolyl)borate (abbreviation: Flr6), bis[2-(4',6'-difluorophenyl)pyridinato-N,C²]iridium(III) picolate (abbreviation: Flrpic), bis {2-[3',5'-bis(trifluoromethyl)phenyl]pyridinato-N, C²}iridium(III) picolate (abbreviation: [Ir(CF₃ppy)₂(pic)]), and bis[2-(4',

6'-difluorophenyl)pyridinato-N, C^{2'}]iridium(III) acetylacetonate (abbreviation: FIracac). Among the materials given above, the organometallic iridium complexes having 4H-triazole skeletons have high reliability and high emission efficiency and are thus especially preferable.

[0151] Examples of the phosphorescent compound having an emission peak at 520 nm to 600 nm include organometallic iridium complexes having pyrimidine skeletons, such as tris(4-methyl-6-phenylpyrimidinato)iridium(III) (abbreviation: [Ir(mppm)₃]), tris(4-*t*-butyl-6-phenylpyrimidinato)iridium(III) (abbreviation: [Ir(tBuppm)₃]), (acetylacetonato)bis(6-methyl-4-phenylpyrimidinato)iridium(III) (abbreviation: [Ir(mppm)₂(acac)]), (acetylacetonato)bis(6-*tert*-butyl-4-phenylpyrimidinato)iridium(III) (abbreviation: [Ir(tBuppm)₂(acac)]), (acetylacetonato)bis[4-(2-norbornyl)-6-phenylpyrimidinato]iridium(III) (endo- and exo-mixture) (abbreviation: [Ir(nbppm)₂(acac)]), (acetylacetonato)bis[5-methyl-6-(2-methylphenyl)-4-phenylpyrimidinato]iridium(III) (abbreviation: [Ir(mpppm)₂(acac)]), and (acetylacetonato)bis(4,6-diphenylpyrimidinato)iridium(III) (abbreviation: [Ir(dppm)₂(acac)]); organometallic iridium complexes having pyrazine skeletons, such as (acetylacetonato)bis(3,5-dimethyl-2-phenylpyrazinato)iridium(III) (abbreviation: [Ir(mppr-Me)₂(acac)]) and (acetylacetonato)bis(5-isopropyl-3-methyl-2-phenylpyrazinato)iridium(III) (abbreviation: [Ir(mppr-iPr)₂(acac)]); organometallic iridium complexes having pyridine skeletons, such as tris(2-phenylpyridinato-N,C^{2'})iridium(III) (abbreviation: [Ir(ppy)₃]), bis(2-phenylpyridinato-N,C^{2'})iridium(III) acetylacetonate (abbreviation: [Ir(ppy)₂(acac)]), bis(benzo[h]quinolinato)iridium(III) acetylacetonate (abbreviation: [Ir(bzq)₂(acac)]), tris(benzo[h]quinolinato)iridium(III) (abbreviation: [Ir(bzq)₃]), tris(2-phenylquinolinato-N,C^{2'})iridium(III) (abbreviation: [Ir(pq)₃]), and bis(2-phenylquinolinato-N,C^{2'})iridium(III) acetylacetonate (abbreviation: [Ir(pq)₂(acac)]); and a rare earth metal complex such as tris(acetylacetonato)(monophenanthroline)terbium(III) (abbreviation: [Tb(acac)₃(Phen)]). Among the above materials, the organometallic iridium complexes having pyrimidine skeletons are particularly preferable because of their distinctively high reliability and emission efficiency.

[0152] Examples of the phosphorescent compound having an emission peak at 600 nm to 700 nm include organometallic iridium complexes having pyrimidine skeletons, such as (diisobutylmethanato)bis[4,6-bis(3-methylphenyl)pyrimidinato]iridium(III) (abbreviation: [Ir(5mdppm)₂(dibm)]), bis[4,6-bis(3-methylphenyl)pyrimidinato](dipivaloylmethanato)iridium(III) (abbreviation: [Ir(5mdppm)₂(dpm)]), and bis[4,6-di(naphthalen-1-yl)pyrimidinato](dipivaloylmethanato)iridium(III) (abbreviation: [Ir(dlnpm)₂(dpm)]); organometallic iridium complexes having pyrazine skeletons, such as (acetylacetonato)bis(2,3,5-triphenylpyrazinato)iridium(III) (abbreviation: [Ir(tppr)₂(acac)]), bis(2,3,5-triphenylpyrazinato)(dipivaloylmethanato)iridium(III) (abbreviation: [Ir(tppr)₂(dpm)]), and (acetylacetonato)bis[2,3-bis(4-fluorophenyl)quinoxalinato]iridium(III) (abbreviation: [Ir(Fdpq)₂(acac)]); organometallic iridium complexes having pyridine skeletons, such as tris(1-phenylisoquinolinato-N,C^{2'})iridium(III) (abbreviation: [Ir(piq)₃]) and bis(1-phenylisoquinolinato-N,C^{2'})iridium(III) acetylacetonate (abbreviation: [Ir(piq)₂(acac)]); a platinum complex such as 2,3,7,8,12,13,17,18-octaethyl-21H,23H-porphyrin platinum(II) (abbreviation: PtOEP); and rare earth metal complexes such as tris(1,3-diphenyl-1,3-pro-

panedionato) (monophenanthroline)europium(III) (abbreviation: [Eu(DBM)₃(Phen)]) and tris[1-(2-thenoyl)-3,3,3-trifluoroacetato](monophenanthroline)europium(III) (abbreviation: [Eu(TTA)₃(Phen)]). Among the materials given above, the organometallic iridium complexes having pyrimidine skeletons have distinctively high reliability and emission efficiency and are thus especially preferable. Furthermore, the organometallic iridium complexes having pyrazine skeletons can provide red light emission with favorable chromaticity.

[0153] Alternatively, a high molecular compound can be used for the light-emitting layer **303**. Examples of the materials that emit blue light include poly(9,9-dioctylfluorene-2,7-diyl) (abbreviation: POF), poly[(9,9-dioctylfluorene-2,7-diyl-co-(2,5-dimethoxybenzene-1,4-diyl)] (abbreviation: PF-DMOP), and poly{(9,9-dioctylfluorene-2,7-diyl)-co-[N,N-di-(*p*-butylphenyl)-1,4-diaminobenzene]} (abbreviation: TAB-PFH). Examples of the materials that emit green light include poly(*p*-phenylenevinylene) (abbreviation: PPV), poly[(9,9-dihexylfluorene-2,7-diyl)-alt-co-(benzo[2,1,3]thiadiazole-4,7-diyl)] (abbreviation: PFBT), and poly[(9,9-dioctyl-2,7-divinylene)fluorenylene]-alt-co-(2-methoxy-5-(2-ethylhexoxy)-1,4-phenylene)]. Examples of the materials that emit orange to red light include poly[2-methoxy-5-(2-ethylhexoxy)-1,4-phenylenevinylene] (abbreviation: MEH-PPV), poly(3-butylthiophene-2,5-diyl), poly {[9,9-dihexyl-2,7-bis(1-cyanovinylene)fluorenylene]-alt-co-[2,5-bis(N,N-diphenylamino)-1,4-phenylene]}, and poly {[2-methoxy-5-(2-ethylhexoxy)-1,4-bis(1-cyanovinylene)phenylene]-alt-co-[2,5-bis(N,N-diphenylamino)-1,4-phenylene]} (abbreviation: CN-PPV-DPD).

<Hole-Transport Layer>

[0154] The hole-transport layer **302** contains a substance with a high hole-transport property.

[0155] The substance with a high hole-transport property is a substance having a hole-transport property higher than an electron-transport property, and is especially preferably a substance with a hole mobility of 10⁻⁶ cm²/Vs or more.

[0156] For the hole-transport layer **302**, it is possible to use any of the compounds which easily accept holes and are described as examples of the substance applicable to the light-emitting layer **303**.

[0157] It is also possible to use an aromatic hydrocarbon compound such as 2-*tert*-butyl-9,10-di(2-naphthyl)anthracene (abbreviation: *t*-BuDNA), 9,10-di(2-naphthyl)anthracene (abbreviation: DNA), or 9,10-diphenylanthracene (abbreviation: DPAnth).

<Electron-Transport Layer>

[0158] The electron-transport layer **304** contains a substance with a high electron-transport property.

[0159] The substance with a high electron-transport property is an organic compound having an electron-transport property higher than a hole-transport property, and is especially preferably a substance with an electron mobility of 10⁻⁶ cm²/Vs or more.

[0160] For the electron-transport layer **304**, it is possible to use any of the compounds which easily accept electrons and are described as examples of the substance applicable to the light-emitting layer **303**.

<Hole-Injection Layer>

[0161] The hole-injection layer 301 contains a substance with a high hole-injection property.

[0162] Examples of the substance with a high hole-injection property include metal oxides such as molybdenum oxide, titanium oxide, vanadium oxide, rhenium oxide, ruthenium oxide, chromium oxide, zirconium oxide, hafnium oxide, tantalum oxide, silver oxide, tungsten oxide, and manganese oxide.

[0163] Alternatively, it is possible to use a phthalocyanine-based compound such as phthalocyanine (abbreviation: H₂Pc) or copper(II) phthalocyanine (abbreviation: CuPc).

[0164] Further alternatively, it is possible to use an aromatic amine compound which is a low molecular organic compound, such as TDATA, MTDATA, DPAB, DNTPD, 1,3,5-tris[N-(4-diphenylaminophenyl)-N-phenylamino]benzene (abbreviation: DPA3B), PCzPCA1, PCzPCA2, or PCzPCN1.

[0165] Further alternatively, it is possible to use a high molecular compound such as PVK, PVTPA, PTPDMA, or Poly-TPD, or a high molecular compound to which acid is added, such as poly(3,4-ethylenedioxythiophene)/poly(styrenesulfonic acid) (PEDOT/PSS) or polyaniline/poly(styrenesulfonic acid) (PANI/PSS).

[0166] The hole-injection layer 301 may serve as the charge-generation region. When the hole-injection layer 301 in contact with the anode serves as the charge-generation region, any of a variety of conductive materials can be used for the anode regardless of their work functions. Materials contained in the charge-generation region will be described below.

<Electron-Injection Layer>

[0167] The electron-injection layer 305 contains a substance with a high electron-injection property.

[0168] Examples of the substance with a high electron-injection property include an alkali metal, an alkaline earth metal, a rare earth metal, and a compound thereof (e.g., an oxide thereof, a carbonate thereof, and a halide thereof), such as lithium, cesium, calcium, lithium oxide, lithium carbonate, cesium carbonate, lithium fluoride, cesium fluoride, calcium fluoride, and erbium fluoride. Electride can also be used. As an example of electride, a substance in which electrons are added at high concentration to an oxide containing calcium and aluminum.

[0169] The electron-injection layer 305 may serve as the charge-generation region. When the electron-injection layer 305 in contact with the cathode serves as the charge-generation region, any of a variety of conductive materials can be used for the cathode regardless of their work functions. Materials contained in the charge-generation region will be described below.

<Charge-Generation Region>

[0170] The charge-generation region may have either a structure in which an electron acceptor (acceptor) is added to an organic compound with a high hole-transport property or a structure in which an electron donor (donor) is added to an organic compound with a high electron-transport property. Alternatively, these structures may be stacked.

[0171] As examples of an organic compound with a high hole-transport property, the above materials which can be used for the hole-transport layer can be given, and as

examples of an organic compound with a high electron-transport property, the above materials which can be used for the electron-transport layer can be given.

[0172] Furthermore, as the electron acceptor, 7,7,8,8-tetracyano-2,3,5,6-tetrafluoroquinodimethane (abbreviation: F₄-TCNQ), chloranil, and the like can be given. In addition, a transition metal oxide can be given. In addition, an oxide of metals that belong to Group 4 to Group 8 of the periodic table can be given. Specifically, vanadium oxide, niobium oxide, tantalum oxide, chromium oxide, molybdenum oxide, tungsten oxide, manganese oxide, and rhenium oxide are preferable because of their high electron-accepting properties. Among these, molybdenum oxide is especially preferable since it is stable in the air, has a low hygroscopic property, and is easy to handle.

[0173] Furthermore, as the electron donor, it is possible to use an alkali metal, an alkaline earth metal, a rare earth metal, a metal belonging to Group 2 or Group 13 of the periodic table, or an oxide or a carbonate thereof. Specifically, lithium, cesium, magnesium, calcium, ytterbium, indium, lithium oxide, cesium carbonate, or the like is preferably used. Alternatively, an organic compound such as tetrathianaphthacene may be used as the electron donor.

[0174] The above-described layers included in the EL layer 203 and the intermediate layer 207 can be formed separately by any of the following methods: an evaporation method (including a vacuum evaporation method), a transfer method, a printing method, an inkjet method, a coating method, and the like.

[0175] This embodiment can be freely combined with any of other embodiments.

Embodiment 3

[0176] In this embodiment, a light-emitting device of one embodiment of the present invention will be described with reference to FIGS. 2A and 2B and FIGS. 3A to 3C. The light-emitting device of this embodiment includes the light-emitting element of one embodiment of the present invention. Since the light-emitting element has a long lifetime, a light-emitting device having high reliability can be provided.

[0177] FIG. 2A is a plan view of a light-emitting device of one embodiment of the present invention, and FIG. 2B is a cross-sectional view taken along dashed-dotted line A-B in FIG. 2A.

[0178] In the light-emitting device of this embodiment, a light-emitting element 403 is provided in a space 415 surrounded by a support substrate 401, a sealing substrate 405, and a sealing material 407. The light-emitting element 403 is an organic EL element having a bottom-emission structure; specifically, a first electrode 421 which transmits visible light is provided over the support substrate 401, an EL layer 423 is provided over the first electrode 421, and a second electrode 425 which reflects visible light is provided over the EL layer 423. The EL layer 423 contains the heterocyclic compound of one embodiment of the present invention which is described in Embodiment 1.

[0179] A first terminal 409a is electrically connected to an auxiliary wiring 417 and the first electrode 421. An insulating layer 419 is provided over the first electrode 421 in a region which overlaps with the auxiliary wiring 417. The first terminal 409a is electrically insulated from the second electrode 425 by the insulating layer 419. A second terminal 409b is electrically connected to the second electrode 425.

Note that although the first electrode **421** is formed over the auxiliary wiring **417** in this embodiment, the auxiliary wiring **417** may be formed over the first electrode **421**.

[0180] A light extraction structure **411a** is preferably provided at the interface between the support substrate **401** and the atmosphere. When provided at the interface between the support substrate **401** and the atmosphere, the light extraction structure **411a** can reduce light that cannot be extracted to the atmosphere because of total reflection, resulting in an increase in the light extraction efficiency of the light-emitting device.

[0181] In addition, a light extraction structure **411b** is preferably provided at the interface between the light-emitting element **403** and the support substrate **401**. When the light extraction structure **411b** has unevenness, a planarization layer **413** is preferably provided between the light extraction structure **411b** and the first electrode **421**. Accordingly, the first electrode **421** can be a flat film, and generation of leakage current in the EL layer **423** due to the unevenness of the first electrode **421** can be prevented. Furthermore, because of the light extraction structure **411b** at the interface between the planarization layer **413** and the support substrate **401**, light that cannot be extracted to the atmosphere because of total reflection can be reduced, so that the light extraction efficiency of the light-emitting device can be increased.

[0182] As a material of the light extraction structure **411a** and the light extraction structure **411b**, a resin can be used, for example. Alternatively, for the light extraction structure **411a** and the light extraction structure **411b**, a hemispherical lens, a micro lens array, a film provided with an uneven surface structure, a light diffusing film, or the like can be used. For example, the light extraction structure **411a** and the light extraction structure **411b** can be formed by attaching the lens or film to the support substrate **401** with an adhesive or the like which has substantially the same refractive index as the support substrate **401** or the lens or film.

[0183] The surface of the planarization layer **413** which is in contact with the first electrode **421** is flatter than the surface of the planarization layer **413** which is in contact with the light extraction structure **411b**. As a material of the planarization layer **413**, glass, liquid, a resin, or the like having a light-transmitting property and a high refractive index can be used.

[0184] FIG. 3A is a plan view of a light-emitting device of one embodiment of the present invention, FIG. 3B is a cross-sectional view taken along dashed-dotted line C-D in FIG. 3A, and FIG. 3C is a cross-sectional view illustrating a modified example of the light-emitting portion.

[0185] An active matrix light-emitting device of this embodiment includes, over a support substrate **501**, a light-emitting portion **551** (the cross section of which is illustrated in FIG. 3B and FIG. 3C as a light-emitting portion **551a** and a light-emitting portion **551b**, respectively), a driver circuit portion **552** (gate side driver circuit portion), a driver circuit portion **553** (source side driver circuit portion), and a sealing material **507**. The light-emitting portion **551** and the driver circuit portions **552** and **553** are sealed in a space **515** surrounded by the support substrate **501**, a sealing substrate **505**, and the sealing material **507**.

[0186] Any of a separate coloring method, a color filter method, and a color conversion method can be applied to the light-emitting device of one embodiment of the present invention. The light-emitting portion **551a** fabricated by a

color filter method is illustrated in FIG. 3B, and the light-emitting portion **551b** fabricated by a separate coloring method is illustrated in FIG. 3C.

[0187] Each of the light-emitting portion **551a** and the light-emitting portion **551b** includes a plurality of light-emitting units each including a switching transistor **541a**, a current control transistor **541b**, and a second electrode **525** electrically connected to a wiring (a source electrode or a drain electrode) of the current control transistor **541b**.

[0188] A light-emitting element **503** included in the light-emitting portion **551a** has a bottom-emission structure and includes a first electrode **521** which transmits visible light, an EL layer **523**, and the second electrode **525**. Furthermore, a partition **519** is formed so as to cover an end portion of the first electrode **521**.

[0189] A light-emitting element **504** included in the light-emitting portion **551b** has a top-emission structure and includes a first electrode **561**, an EL layer **563**, and the second electrode **565** which transmits visible light. Furthermore, the partition **519** is formed so as to cover an end portion of the first electrode **561**. In the EL layer **563**, at least layers (e.g., light-emitting layers) which contain a variable material depending on the light-emitting element are colored separately.

[0190] Over the support substrate **501**, a lead wiring **517** for connecting an external input terminal through which a signal (e.g., a video signal, a clock signal, a start signal, or a reset signal) or a potential from the outside is transmitted to the driver circuit portion **552** or **553** is provided. Here, an example is described in which a flexible printed circuit (FPC) **509** is provided as the external input terminal.

[0191] The driver circuit portions **552** and **553** include a plurality of transistors. FIG. 3B illustrates two of the transistors in the driver circuit portion **552** (transistors **542** and **543**).

[0192] To prevent an increase in the number of manufacturing steps, the lead wiring **517** is preferably formed using the same material and the same step(s) as those of the electrode or the wiring in the light-emitting portion or the driver circuit portion. Described in this embodiment is an example in which the lead wiring **517** is formed using the same material and the same step(s) as those of the source electrodes and the drain electrodes of the transistors included in the light-emitting portion **551** and the driver circuit portion **552**.

[0193] In FIG. 3B, the sealing material **507** is in contact with a first insulating layer **511** over the lead wiring **517**. The adhesion of the sealing material **507** to metal is low in some cases. Therefore, the sealing material **507** is preferably in contact with an inorganic insulating film over the lead wiring **517**. Such a structure enables a light-emitting device to have high sealing capability, high adhesion, and high reliability. Examples of the inorganic insulating film include oxide films of metals and semiconductors, nitride films of metals and semiconductors, and oxynitride films of metals and semiconductors, and specifically, a silicon oxide film, a silicon nitride film, a silicon oxynitride film, a silicon nitride oxide film, an aluminum oxide film, a titanium oxide film, and the like.

[0194] The first insulating layer **511** has an effect of preventing diffusion of impurities into a semiconductor included in the transistor. As the second insulating layer **513**,

an insulating film having a planarization function is preferably selected in order to reduce surface unevenness due to the transistor.

[0195] There is no particular limitation on the structure and materials of the transistor used in the light-emitting device of one embodiment of the present invention. A top-gate transistor may be used, or a bottom-gate transistor such as an inverted staggered transistor may be used. The transistor may be a channel-etched transistor or a channel-protective transistor. An n-channel transistor may be used and a p-channel transistor may also be used.

[0196] A semiconductor layer can be formed using silicon or an oxide semiconductor. It is preferable that the transistor be formed using an oxide semiconductor which is an In—Ga—Zn-based metal oxide for a semiconductor layer so as to have low off-state current because an off-state leakage current of the light-emitting element can be reduced.

[0197] The sealing substrate 505 illustrated in FIG. 3B is provided with a color filter 533 as a coloring layer at a position overlapping with the light-emitting element 503 (a light-emitting region thereof), and is also provided with a black matrix 531 at a position overlapping with the partition 519. Furthermore, an overcoat layer 535 is provided so as to cover the color filter 533 and the black matrix 531. The sealing substrate 505 illustrated in FIG. 3C is provided with a desiccant 506.

[0198] This embodiment can be combined with any other embodiment as appropriate.

Embodiment 4

[0199] In this embodiment, examples of electronic devices and lighting devices to which the light-emitting device of one embodiment of the present invention is applied will be described with reference to FIGS. 4A to 4E and FIGS. 5A and 5B.

[0200] Electronic devices of this embodiment each include the light-emitting device of one embodiment of the present invention in a display portion. Lighting devices of this embodiment each include the light-emitting device of one embodiment of the present invention in a light-emitting portion (a lighting portion). Highly reliable electronic devices and highly reliable lighting devices can be provided by adopting the light-emitting device of one embodiment of the present invention.

[0201] Examples of electronic devices to which the light-emitting device is applied are television devices (also referred to as TV or television receivers), monitors for computers and the like, cameras such as digital cameras and digital video cameras, digital photo frames, cellular phones (also referred to as mobile phones or portable telephone devices), portable game machines, portable information terminals, audio playback devices, large game machines such as pin-ball machines, and the like. Specific examples of these electronic devices and lighting devices are illustrated in FIGS. 4A to 4E and FIGS. 5A and 5B.

[0202] FIG. 4A illustrates an example of a television device. In a television device 7100, a display portion 7102 is incorporated in a housing 7101. The display portion 7102 is capable of displaying images. The light-emitting device of one embodiment of the present invention can be used for the display portion 7102. In addition, here, the housing 7101 is supported by a stand 7103.

[0203] The television device 7100 can be operated with an operation switch provided in the housing 7101 or a separate

remote controller 7111. With operation keys of the remote controller 7111, channels and volume can be controlled and images displayed on the display portion 7102 can be controlled. The remote controller 7111 may be provided with a display portion for displaying data output from the remote controller 7111.

[0204] Note that the television device 7100 is provided with a receiver, a modem, and the like. With the use of the receiver, general television broadcasting can be received. Moreover, when the television device is connected to a communication network with or without wires via the modem, one-way (from a sender to a receiver) or two-way (between a sender and a receiver or between receivers) information communication can be performed.

[0205] FIG. 4B illustrates an example of a computer. A computer 7200 includes a main body 7201, a housing 7202, a display portion 7203, a keyboard 7204, an external connection port 7205, a pointing device 7206, and the like. Note that this computer is manufactured by using the light-emitting device of one embodiment of the present invention for the display portion 7203.

[0206] FIG. 4C illustrates an example of a portable game machine. A portable game machine 7300 has two housings, a housing 7301a and a housing 7301b, which are connected with a joint portion 7302 so that the portable game machine can be opened or closed. The housing 7301a incorporates a display portion 7303a, and the housing 7301b incorporates a display portion 7303b. In addition, the portable game machine illustrated in FIG. 4C includes a speaker portion 7304, a recording medium insertion portion 7305, an operation key 7306, a connection terminal 7307, a sensor 7308 (a sensor having a function of measuring or sensing force, displacement, position, speed, acceleration, angular velocity, rotational frequency, distance, light, liquid, magnetism, temperature, chemical substance, sound, time, hardness, electric field, electric current, voltage, electric power, radiation, flow rate, humidity, gradient, oscillation, odor, or infrared rays), an LED lamp, a microphone, and the like. It is needless to say that the structure of the portable game machine is not limited to the above structure as long as the light-emitting device of one embodiment of the present invention is used for at least either the display portion 7303a or the display portion 7303b, or both, and may include other accessories as appropriate. The portable game machine illustrated in FIG. 4C has a function of reading out a program or data stored in a recording medium to display it on the display portion, and a function of sharing information with another portable game machine by wireless communication. Note that functions of the portable game machine illustrated in FIG. 4C are not limited to them, and the portable game machine can have various functions.

[0207] FIG. 4D illustrates an example of a cellular phone. A cellular phone 7400 is provided with a display portion 7402 incorporated in a housing 7401, an operation button 7403, an external connection port 7404, a speaker 7405, a microphone 7406, and the like. Note that the cellular phone 7400 is manufactured by using the light-emitting device of one embodiment of the present invention for the display portion 7402.

[0208] When the display portion 7402 of the cellular phone 7400 illustrated in FIG. 4D is touched with a finger or the like, data can be input into the cellular phone. Furthermore, operations such as making a call and creating

e-mail can be performed by touching the display portion 7402 with a finger or the like.

[0209] There are mainly three screen modes of the display portion 7402. The first mode is a display mode mainly for displaying an image. The second mode is an input mode mainly for inputting information such as characters. The third mode is a display-and-input mode in which two modes of the display mode and the input mode are combined.

[0210] For example, in the case of making a call or creating e-mail, a text input mode mainly for inputting text is selected for the display portion 7402 so that text displayed on the screen can be input.

[0211] When a sensing device including a sensor such as a gyroscope sensor or an acceleration sensor for detecting inclination is provided inside the cellular phone 7400, display on the screen of the display portion 7402 can be automatically changed in direction by determining the orientation of the cellular phone 7400 (whether the cellular phone 7400 is placed horizontally or vertically for a landscape mode or a portrait mode).

[0212] The screen modes are changed by touch on the display portion 7402 or operation with the operation button 7403 of the housing 7401. The screen modes can be switched depending on the kind of images displayed on the display portion 7402. For example, when a signal of an image displayed on the display portion is a signal of moving image data, the screen mode is switched to the display mode. When the signal is a signal of text data, the screen mode is switched to the input mode.

[0213] Moreover, in the input mode, if a signal detected by an optical sensor in the display portion 7402 is detected and the input by touch on the display portion 7402 is not performed for a certain period, the screen mode may be controlled so as to be changed from the input mode to the display mode.

[0214] The display portion 7402 may function as an image sensor. For example, an image of a palm print, a fingerprint, or the like is taken by the display portion 7402 while in touch with the palm or the finger, whereby personal authentication can be performed. Furthermore, when a backlight or a sensing light source which emits near-infrared light is provided in the display portion, an image of a finger vein, a palm vein, or the like can be taken.

[0215] FIG. 4E illustrates an example of a foldable tablet terminal (in an open state). A tablet terminal 7500 includes a housing 7501a, a housing 7501b, a display portion 7502a, and a display portion 7502b. The housing 7501a and the housing 7501b are connected by a hinge 7503 and can be opened and closed using the hinge 7503 as an axis. The housing 7501a includes a power switch 7504, operation keys 7505, a speaker 7506, and the like. Note that the tablet terminal 7500 is manufactured by using the light-emitting device of one embodiment of the present invention for either the display portion 7502a or the display portion 7502b, or both.

[0216] Part of the display portion 7502a or the display portion 7502b can be used as a touch panel region, where data can be input by touching displayed operation keys. For example, a keyboard can be displayed on the entire region of the display portion 7502a so that the display portion 7502a is used as a touch panel, and the display portion 7502b can be used as a display screen.

[0217] An indoor lighting device 7601, a roll-type lighting device 7602, a desk lamp 7603, and a planar lighting device

7604 illustrated in FIG. 5A are each an example of a lighting device which includes the light-emitting device of one embodiment of the present invention. Since the light-emitting device of one embodiment of the present invention can have a larger area, it can be used as a large-area lighting device. Furthermore, since the light-emitting device is thin, the light-emitting device can be mounted on a wall.

[0218] A desk lamp illustrated in FIG. 5B includes a lighting portion 7701, a support 7703, a support base 7705, and the like. The light-emitting device of one embodiment of the present invention is used for the lighting portion 7701. In one embodiment of the present invention, a lighting device whose light-emitting portion has a curved surface or a lighting device including a flexible lighting portion can be achieved. Such use of a flexible light-emitting device for a lighting device enables a place having a curved surface, such as the ceiling or dashboard of a motor vehicle, to be provided with the lighting device, as well as increases the degree of freedom in design of the lighting device.

[0219] This embodiment can be combined with any other embodiment as appropriate.

Example 1

Synthesis Example 1

[0220] This example describes a method for synthesizing 2-{3-[3-(benzo[b]naphtho[1,2-d]furan-8-yl)phenyl]phenyl}dibenzo[f,h]quinoxaline (abbreviation: 2mBnfBPDBq) represented by Structural Formula (101). This example also describes a method for synthesizing 2-(benzo[b]naphtho[1,2-d]furan-8-yl)-4,4,5,5-tetramethyl-1,3,2-dioxaborolane that is an organic compound of one embodiment of the present invention represented by Structural Formula (201).

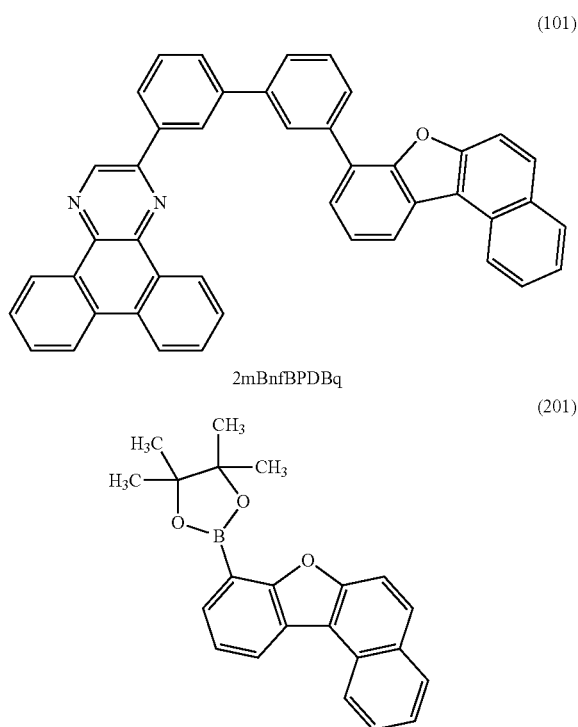

Step 1: Synthesis of
3-Chloro-2-fluorobenzeneboronic Acid

[0221] A synthesis scheme of Step 1 is shown in (B-1).

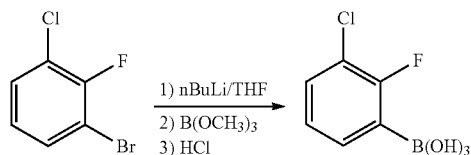

[0222] In a 500 mL three-neck flask was put 16 g (72 mmol) of 1-bromo-3-chloro-2-fluorobenzene, and the air in the flask was replaced with nitrogen; then, 200 mL of tetrahydrofuran (THF) was added and the solution was cooled down to -80°C . under a nitrogen stream. To this solution, 48 mL (76 mmol) of *n*-butyl lithium (a 1.6 mol/L hexane solution) was added dropwise with a syringe, and then the mixture was stirred for 1.5 hours at the same temperature. After the stirring, 9.0 mL (80 mmol) of trimethyl borate was added to this mixture. While the temperature was raised to room temperature, the mixture was stirred for approximately 19 hours. After the stirring, approximately 100 mL of a 1 mol/L hydrochloric acid was added to the resulting solution and the mixture was stirred. The organic layer of this mixture was washed with water and the aqueous layer was subjected to extraction with toluene twice. The solution of the extract and the organic layer were combined and washed with saturated brine. The resulting organic layer was dried with magnesium sulfate, and this mixture was gravity-filtered. The resulting filtrate was concentrated to give 4.5 g of a pale yellow solid of a target substance, in a yield of 35%.

Step 2: Synthesis of
1-(3-Chloro-2-fluorophenyl)-2-naphthol

[0223] A synthesis scheme of Step 2 is shown in (B-2).

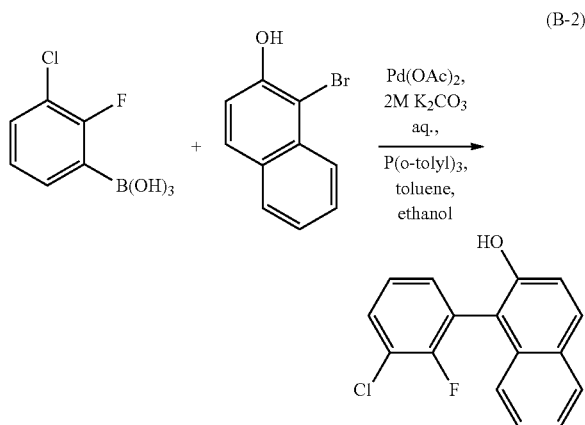

[0224] In a 200 mL three-neck flask were put 5.8 g (26 mmol) of 1-bromo-2-naphthol, 4.5 g (26 mmol) of 3-chloro-2-fluorobenzeneboronic acid, and 0.40 g (1.3 mmol) of tri(*ortho*-tolyl)phosphine, and the air in the flask was

replaced with nitrogen. To this mixture, 150 mL of toluene, 50 mL of ethanol, and 21 mL of an aqueous solution of potassium carbonate (2.0 mol/L) were added. The mixture was degassed by being stirred while the pressure in the flask was reduced; then, the air in the flask was replaced with nitrogen. To this mixture was added 58 mg (0.26 mmol) of palladium(II) acetate, and the resulting mixture was stirred at 90°C . under a nitrogen stream for 7 hours. After the stirring, the organic layer of the mixture was washed with water and the aqueous layer was subjected to extraction with toluene. The solution of the extract combined with the organic layer was washed with saturated brine, and the organic layer was dried with magnesium sulfate. The resulting mixture was gravity-filtered, and the resulting filtrate was concentrated to give a brown liquid. The liquid was purified by silica gel column chromatography using a mixed solvent (toluene: hexane=9:1) as a developing solvent, so that 3.1 g of a brown liquid of a target substance was produced in a yield of 44%.

Step 3: Synthesis of
8-Chlorobenzo[*b*]naphtho[1,2-*d*]furan

[0225] A synthesis scheme of Step 3 is shown in (B-3).

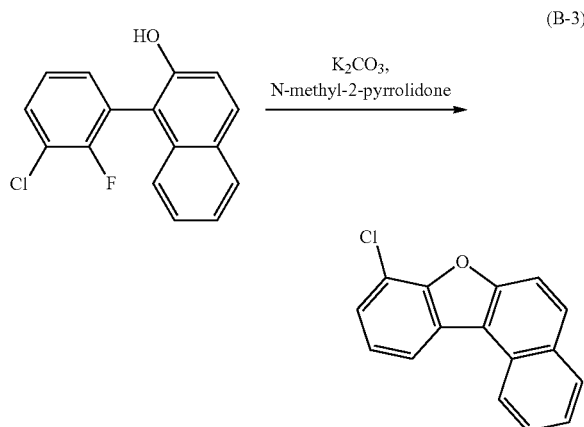

[0226] In a 300 mL recovery flask were put 3.1 g (11 mmol) of 1-(3-chloro-2-fluorophenyl)-2-naphthol, 70 mL of *N*-methyl-2-pyrrolidone, and 4.2 g (31 mmol) of potassium carbonate, and this mixture was stirred at 150°C . in the air for 7 hours. After the stirring, approximately 50 mL of water and approximately 50 mL of hydrochloric acid (1.0 mol/L) were added to the resulting mixture. To the resulting solution was added approximately 100 mL of ethyl acetate; then, the aqueous layer was subjected to extraction with ethyl acetate three times. The solution of the extract combined with the organic layer was washed with a saturated aqueous solution of sodium hydrogen carbonate and saturated brine, and magnesium sulfate was then added. The mixture was gravity-filtered, and the resulting filtrate was concentrated to give 2.9 g of a pale brown solid of a target substance in a yield of over 99%.

[0227] ^1H NMR data of the pale brown solid are as follows:

[0228] ^1H NMR (CDCl_3 , 500 MHz): δ =7.42 (t, J =4.7 Hz, 1H), 7.51 (d, J =4.5 Hz, 1H), 7.58 (t, J =4.5 Hz, 1H), 7.75 (t,

J=4.5 Hz, 1H), 7.85 (d, J=5.4 Hz, 1H), 7.98 (d, J=5.1 Hz, 1H), 8.05 (d, J=4.8 Hz, 1H), 8.30 (d, J=4.2 Hz, 1H), 8.59 (d, J=4.8 Hz, 1H).

Step 4: Synthesis of 2-(Benzo[b]naphtho[1,2-d]furan-8-yl)-4,4,5,5-tetramethyl-1,3,2-dioxaborolane

[0229] A synthesis scheme of Step 4 is shown in (B-4).

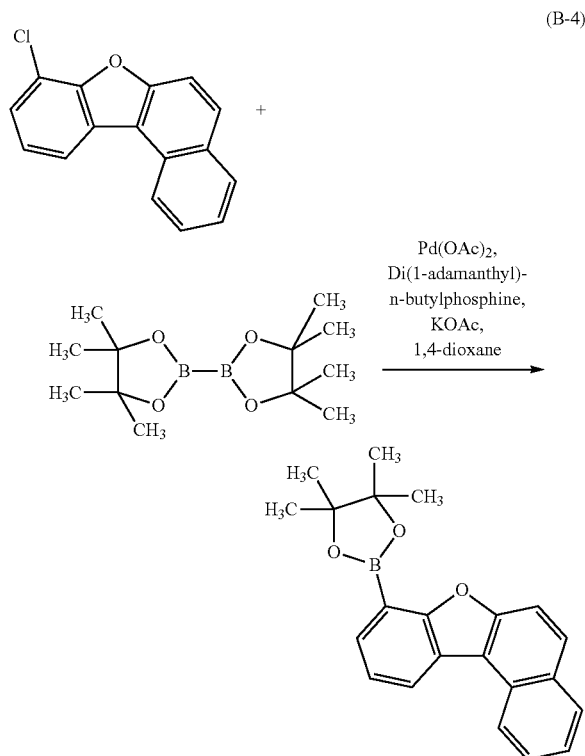

[0230] In a 200 mL three-neck flask were put 2.5 g (10 mmol) of 8-chlorobenzo[b]naphtho[1,2-d]furan, 2.5 g (10 mmol) of bis(pinacolato)diboron, and 2.9 g (30 mmol) of potassium acetate, and the air in the flask was replaced with nitrogen. To this mixture, 50 mL of 1,4-dioxane was added. The mixture was degassed by being stirred while the pressure in the flask was reduced; then, the air in the flask was replaced with nitrogen. To this mixture were added 22 mg (0.10 mmol) of palladium(II) acetate and 71 mg (0.20 mmol) of di(1-adamantyl)-n-butylphosphine, and the mixture was refluxed for 18 hours. After the reflux, the resulting mixture was suction-filtered, and the resulting filtrate was concentrated to give 2.5 g of a brown solid of a target substance in a yield of 73%.

[0231] ¹H NMR data of the brown solid are as follows:

[0232] ¹H NMR (CDCl₃, 500 MHz): δ=1.26 (s, 12H), 7.48 (t, J=4.5 Hz, 1H), 7.54 (dt, J=0.9 Hz, J=4.8 Hz, 1H), 7.71 (dt, J=0.9 Hz, J=4.8 Hz, 1H), 7.88 (d, J=5.1 Hz, 1H), 7.93-7.91 (m, 2H), 8.02 (d, J=4.8 Hz, 1H), 8.51 (dd, J=0.9 Hz, J=4.8 Hz, 1H), 8.63 (d, J=8.6 Hz, 1H).

[0233] In addition, FIGS. 6A and 6B show ¹H NMR charts. Note that FIG. 6B is a chart showing an enlarged part of FIG. 6A in the range of 7.00 ppm to 9.00 ppm.

Step 5: Synthesis of 2mBnfBPDBq

[0234] A synthesis scheme of Step 5 is shown in (B-5).

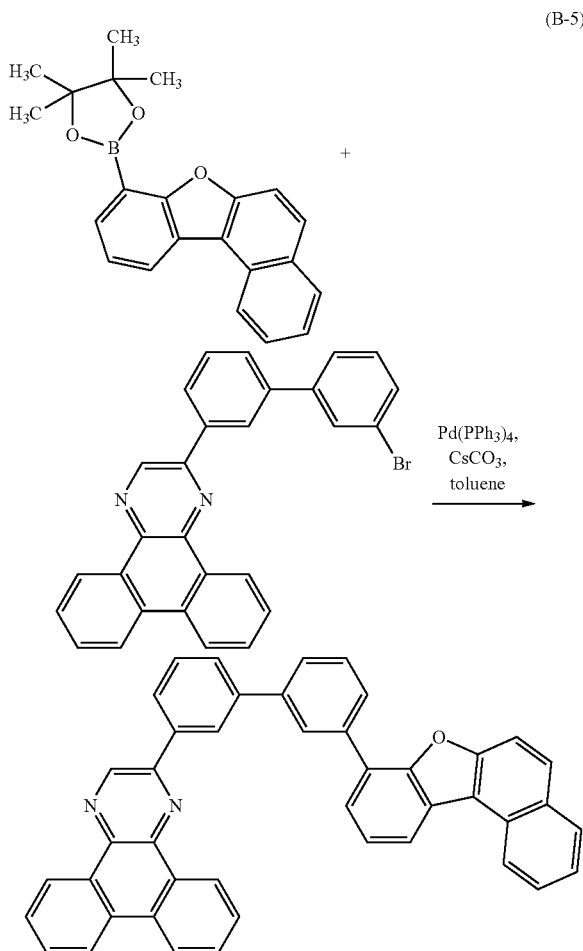

[0235] In a 200 mL three-neck flask were put 1.5 g (3.2 mmol) of 2-(3'-bromobiphenyl-3-yl)dibenzo[f,h]quinoxaline, 1.1 g (3.2 mmol) of 2-(benzo[b]naphtho[1,2-d]furan-8-yl)-4,4,5,5-tetramethyl-1,3,2-dioxaborolane, and 3.2 g (10 mmol) of cesium carbonate, and the air in the flask was replaced with nitrogen. Then, 16 mL of toluene was added to this mixture. The mixture was degassed by being stirred while the pressure in the flask was reduced; then, the air in the flask was replaced with nitrogen. After 34 mg (30 μmol) of tetrakis(triphenylphosphine)palladium(0) was added to this mixture, the mixture was stirred at 100° C. under a nitrogen stream for 10 hours. To the resulting mixture, approximately 100 mL of toluene was added; then, this mixture was refluxed, in which a solid was precipitated and dissolved. This mixture was suction-filtered. The resulting filtrate was left standing, whereby recrystallization occurred. Thus, 1.0 g of a pale yellow solid of a target substance was produced in a yield of 51%.

[0236] By a train sublimation method, 0.76 g of the pale yellow solid was purified. The sublimation purification was conducted by heating of the pale yellow solid at 330° C.

under a pressure of 3.2 Pa. As a result of the sublimation purification, 0.36 g of a pale yellow solid was provided at a collection rate of 51%.

[0237] This compound was identified as 2mBnfBPDBq, which was the target substance, by nuclear magnetic resonance (NMR) spectroscopy.

[0238] ^1H NMR data of the obtained substance are as follows:

[0239] ^1H NMR (CDCl_3 , 500 MHz): $\delta=7.58$ (t, $J=4.2$ Hz, 1H), 7.62 (t, $J=4.7$ Hz, 1H), 7.73-7.86 (m, 10H), 7.90 (d, $J=4.8$ Hz, 1H), 7.92 (d, $J=5.1$ Hz, 1H), 8.04 (t, $J=4.5$ Hz, 2H), 8.32 (s, 1H), 8.36 (d, $J=4.5$ Hz, 1H), 8.45 (d, $J=4.2$ Hz, 1H), 8.66-8.71 (m, 4H), 9.26 (dd, $J=4.5$ Hz, $J_2=1.2$ Hz, 1H), 9.45 (d, $J=4.8$ Hz, 1H), 9.49 (s, 1H).

[0240] In addition, FIGS. 7A and 7B show ^1H NMR charts. Note that FIG. 7B is a chart showing an enlarged part of FIG. 7A in the range of 7.00 ppm to 10.0 ppm.

[0241] Furthermore, FIG. 8A shows an absorption spectrum of a toluene solution of 2mBnfBPDBq, and FIG. 8B shows an emission spectrum thereof. FIG. 9A shows an absorption spectrum of a thin film of 2mBnfBPDBq and FIG. 9B shows an emission spectrum thereof. The absorption spectrum was measured using an ultraviolet-visible spectrophotometer (V-550, produced by JASCO Corporation). The measurements were performed with samples prepared by putting the solution in a quartz cell and depositing the thin film onto a quartz substrate by evaporation. The absorption spectrum of the solution was obtained by subtracting the absorption spectra of the quartz cell and toluene from those of the quartz cell and the solution, and the absorption spectrum of the thin film was obtained by subtracting the absorption spectrum of a quartz substrate from the absorption spectra of the thin film on the quartz substrate. In FIGS. 8A and 8B and FIGS. 9A and 9B, the horizontal axis indicates wavelength (nm) and the vertical axis indicates intensity (arbitrary unit). In the case of the toluene solution, absorption peaks are observed around 355 nm and 368 nm, and emission wavelength peaks are observed at 386 nm and 406 nm (excitation wavelength: 330 nm). In the case of the thin film, absorption peaks are observed around 211 nm, 259 nm, 318 nm, 329 nm, 346 nm, 369 nm, and 384 nm, and an emission wavelength peak is observed at 437 nm (excitation wavelength: 347 nm).

[0242] Electrochemical characteristics of a 2mBnfBPDBq solution were also measured.

[0243] As a measuring method, cyclic voltammetry (CV) measurement was employed. An electrochemical analyzer (ALS model 600A or 600C, produced by BAS Inc.) was used for the measurement.

[0244] For the measurement of the oxidation characteristics, the potential of the working electrode with respect to the reference electrode was scanned from 0.00 V to 1.50 V and then from 1.50 V to 0.00 V. An observed oxidation peak had 76% of the initial intensity even after 100 cycles. This indicates that 2mBnfBPDBq has properties effective against repetition of redox reactions between an oxidized state and a neutral state. FIG. 10A shows the measurement results of the oxidation characteristics.

[0245] For the measurement of the reduction characteristics, the potential of the working electrode with respect to the reference electrode was scanned from -1.05 V to -2.10 V and then from -2.10 V to -1.05 V. An observed reduction peak had 73% of the initial intensity even after 100 cycles. This indicates that 2mBnfBPDBq has properties effective

against repetition of redox reactions between a reduced state and a neutral state. FIG. 10B shows the measurement results of the reduction characteristics.

[0246] As for a solution used for the CV measurement, dehydrated dimethylformamide (DMF, produced by Sigma-Aldrich Co. LLC., 99.8%, catalog No. 22705-6) was used as a solvent, and tetra-n-butylammonium perchlorate ($n\text{-Bu}_4\text{NClO}_4$, produced by Tokyo Chemical Industry Co., Ltd., catalog No. T0836), which was a supporting electrolyte, was dissolved in the solvent such that the concentration of tetra-n-butylammonium perchlorate was 100 mmol/L. Furthermore, the object to be measured was dissolved in the solvent such that the concentration thereof was 2 mmol/L. A platinum electrode (produced by BAS Inc., PTE platinum electrode) was used as a working electrode, a platinum electrode (produced by BAS Inc., Pt counter electrode for VC-3 (5 cm)) was used as an auxiliary electrode, and an Ag/Ag^+ electrode (produced by BAS Inc., RE-7 reference electrode for nonaqueous solvent) was used as a reference electrode. Note that the measurement was conducted at room temperature (20° C. to 25° C.). In addition, the scan rate at the CV measurement was set to 0.1 V/sec in all the measurement. Note that the potential energy of the reference electrode with respect to the vacuum level was assumed to be -4.94 [eV] in this example.

[0247] On the assumption that the intermediate potential (the half-wave potential) between the oxidation peak potential E_{pa} and the reduction peak potential E_{pc} which are obtained in the CV measurement corresponds to the HOMO level, the HOMO level of 2mBnfBPDBq was calculated to be -6.13 eV, and the LUMO level of 2mBnfBPDBq was calculated to be -2.95 eV. Accordingly, the band gap (ΔE) of 2mBnfBPDBq was found to be 3.08 eV.

[0248] Furthermore, 2mBnfBPDBq was subjected to thermogravimetry-differential thermal analysis. The measurement was conducted by using a high vacuum differential type differential thermal balance (TG/DTA 2410SA, produced by Bruker AXS K.K.). The measurement was carried out under a nitrogen stream (flow rate: 200 mL/min) at normal pressure at a temperature rising rate of 10° C./min. From relationship between weight and temperature (thermogravimetry), the 5% weight loss temperature and the melting point of 2mBnfBPDBq were 468° C. and 292° C., respectively. Accordingly, it was shown that 2mBnfBPDBq has high heat resistance.

[0249] Furthermore, 2mBnfBPDBq was subjected to mass spectrometric (MS) analysis by liquid chromatography mass spectrometry (LC-MS).

[0250] In the analysis by LC-MS, liquid chromatography (LC) separation was carried out with UltiMate 3000 manufactured by Thermo Fisher Scientific K.K., and mass spectrometric (MS) analysis was carried out with Q Exactive manufactured by Thermo Fisher Scientific K.K. ACQUITY UPLC BEH C8 (2.1×100 mm, 1.7 μm) was used as a column for the LC separation, and the column temperature was 40° C. Acetonitrile was used for Mobile Phase A and a 0.1% aqueous solution of formic acid was used for Mobile Phase B. Analysis was performed by a gradient method for 5 minutes, in which the proportion of acetonitrile was 80% at the start of the analysis and increased linearly to reach 95% after 5 minutes from the start of the analysis. A sample was prepared in such a manner that 2mBnfBPDBq was dissolved

in dimethylformamide at a given concentration and the mixture was diluted with acetonitrile. The injection amount was 10.0 μL .

[0251] In the MS analysis, ionization was carried out by an electrospray ionization (ESI) method, and measurement was carried out by targeted-MS². Conditions of an ion source were set as follows: the flow rates of a sheath gas, an Aux gas, and a Sweep gas were 50, 10, and 0, respectively, the spray voltage was 3.5 kV, the capillary temperature was 350° C., the S lens voltage was 55.0, and the HESI heater temperature was 350° C. The resolution was 70000, the AGC target was 3e6, the mass range was $m/z=83.00$ to 1245.00, and the detection was performed in a positive mode.

[0252] A component with m/z of 599.21 ± 10 ppm that underwent the ionization under the above-described conditions was collided with an argon gas in a collision cell to dissociate into product ions, and MS/MS measurement was carried out. Ions which were generated under a normalized collision energy (NCE) for the collision with argon of 55 were detected with a Fourier transform mass spectrometer (FT MS). FIGS. 11A and 11B show the measurement results.

[0253] The results in FIGS. 11A and 11B demonstrate that product ions of 2mBnfBPDBq are detected around $m/z=229$ and $m/z=220$. Note that the results in FIGS. 11A and 11B show characteristics derived from 2mBnfBPDBq and thus can be regarded as important data for identifying 2mBnfBPDBq contained in a mixture.

[0254] The product ion around $m/z=229$ is presumed to be a cation derived from dibenzo[f,h]quinoxaline in 2mBnfBPDBq, and indicates a partial structure of the heterocyclic compound of one embodiment of the present invention. The product ion around $m/z=220$ is presumed to be a cation that was derived from an alcohol formed by cleavage of an ether linkage in benzo[b]naphtho[1,2-d]furan (Structural Formula (10) or Structural Formula (11)), and indicates a partial structure of the heterocyclic compound of one embodiment of the present invention.

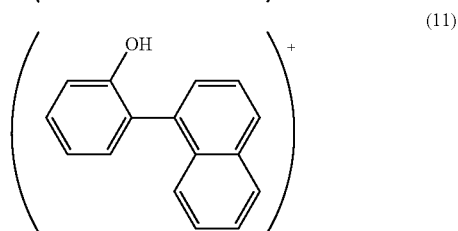
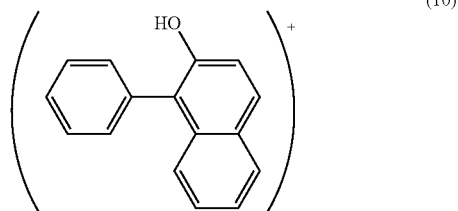

[0255] The product ion around $m/z=572$ is presumed to be a cation derived from 2mBnfBPDBq in the state where one CH and one N are dissociated from dibenzo[f,h]quinoxaline in 2mBnfBPDBq, and indicates a partial structure of the heterocyclic compound of one embodiment of the present

invention. In particular, this is one of features of the heterocyclic compound of one embodiment of the present invention in which a substituent (in 2mBnfBPDBq, a biphenyl skeleton bonded to a benzo[b]naphtho[1,2-d]furan skeleton) is bonded to the 2-position of dibenzo[f,h]quinoxaline.

[0256] Calculation and measurement were performed to find out the T_1 level of 2mBnfBPDBq.

[0257] The calculating method is described below. Note that Gaussian 09 was used as the quantum chemistry computational program. A high performance computer (Altix 4700, manufactured by SGI Japan, Ltd.) was used for the calculations.

[0258] First, the most stable structure in the singlet ground state was calculated using the density functional theory. As a basis function, 6-311G (a basis function of a triple-split valence basis set using three contraction functions for each valence orbital) was applied to all the atoms. By the above basis function, for example, is to 3 s orbitals are considered in the case of hydrogen atoms, while is to 4 s and 2p to 4p orbitals are considered in the case of carbon atoms. Furthermore, to improve calculation accuracy, the p function and the d function as polarization basis sets were added respectively to hydrogen atoms and atoms other than hydrogen atoms. As a functional, B3LYP was used.

[0259] Next, the most stable structure in the lowest excited triplet state was calculated. Then, vibration analysis was conducted on the most stable structures in the singlet ground state and in the lowest excited triplet state, and a zero-point corrected energy difference was obtained. The T_1 level was calculated from the zero-point corrected energy difference. As a basis function, 6-311G (d, p) was used. As a functional, B3LYP was used.

[0260] From the above calculation, the T_1 level of 2mBnfBPDBq was estimated to be 2.41 eV.

[0261] Phosphorescence of 2mBnfBPDBq was measured to support the quantum chemical calculation.

[0262] An evaporated film of 2mBnfBPDBq was formed and was subjected to a low-temperature photoluminescence (PL) method, and the T_1 level thereof was estimated from the measured phosphorescence spectrum. Note that the T_1 level was estimated from a peak wavelength on the shortest wavelength side of the phosphorescence spectrum. The measurement was performed by using a PL microscope, LabRAM HR-PL, produced by HORIBA, Ltd., a He—Cd laser (325 nm) as excitation light, and a CCD detector at a measurement temperature of 10 K.

[0263] For the measurement, a thin film was formed over a quartz substrate to a thickness of 50 nm and another quartz substrate was attached to the deposition surface in a nitrogen atmosphere.

[0264] The measurement results show that 2mBnfBPDBq has a T_1 level of 2.40 eV. The results indicate that the values of the T_1 levels measured in this example are close to the values of the T_1 levels calculated by the quantum chemical calculation. Therefore, the values of the T_1 levels obtained in this example are citable as parameters for forming the light-emitting element of one embodiment of the present invention.

[0265] Example 1 revealed that the heterocyclic compound of one embodiment of the present invention represented by General Formula (G1) has a high T_1 level. Accordingly, the use of the heterocyclic compound of one embodiment of the present invention makes it possible to provide a light-emitting element with high efficiency.

Example 2

[0266] In this example, a T_1 level was calculated to provide evidence that the heterocyclic compound of one embodiment of the present invention has a high T_1 level.

[0267] The calculation method described in Example 1 was used.

[0268] In this example, the T_1 levels of five kinds of partial structures represented by chemical formulae below were calculated. As the partial structures, 8PBnf, 9PBnf, 10PBnf, and 11PBnf, and 6PBnf that is a comparative example were used. Each of 8PBnf, 9PBnf, 10PBnf, and 11PBnf has a structure in which a phenyl group is bonded to any one of the 8- to 11-positions of benzo[b]naphtho[1,2-d]furan (an example of a structure in which a phenyl group is bonded to the benzene ring). Meanwhile, 6PBnf has a structure in which a phenyl group is bonded to the 6-position of benzo[b]naphtho[1,2-d]furan (an example of a structure in which a phenyl group is bonded to the naphthalene ring).

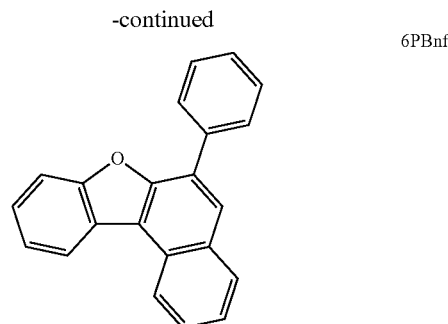

[0269] The calculation results are shown in Table 1.

TABLE 1

T_1 level (eV)	Partial structure				
	8PBnf	9PBnf	10PBnf	11PBnf	6PBnf
T_1 level (eV)	2.41	2.35	2.41	2.38	2.29

8PBnf

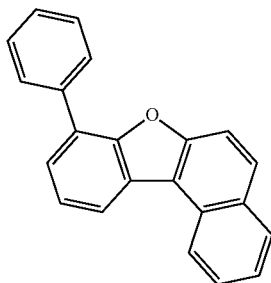

[0270] The results revealed that 8PBnf, 9PBnf, 10PBnf, and 11PBnf, in which the phenyl group is bonded to the benzene ring of benzo[b]naphtho[1,2-d]furan, each have a high T_1 level. Furthermore, 8PBnf, 9PBnf, 10PBnf, and 11PBnf were each found to have a higher T_1 level than 6PBnf as the comparative example, in which a phenyl group is bonded to the naphthalene ring of benzo[b]naphtho[1,2-d]furan. The above shows that the heterocyclic compound of one embodiment of the present invention has a high T_1 level and that the use of the heterocyclic compound makes it possible to provide a light-emitting element with high efficiency.

9PBnf

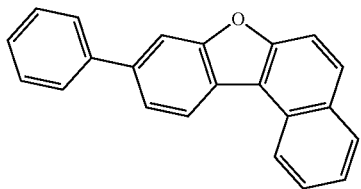

Example 3

[0271] In this example, the light-emitting element of one embodiment of the present invention will be described with reference to FIG. 12. Chemical formulae of materials used in this example are shown below. Note that the chemical formulae of the materials which are shown above are omitted.

10PBnf

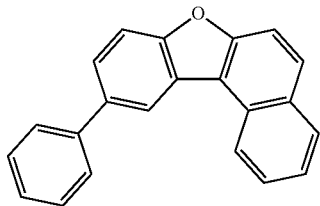

11PBnf

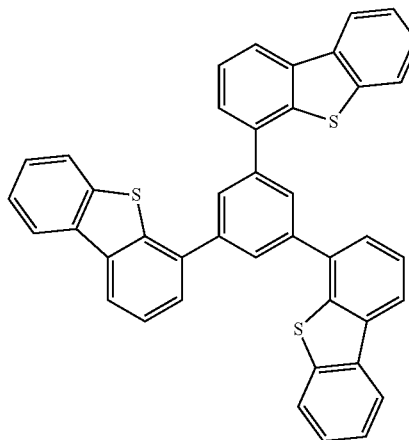
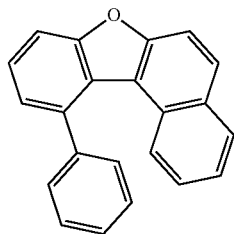

DBT3P-II

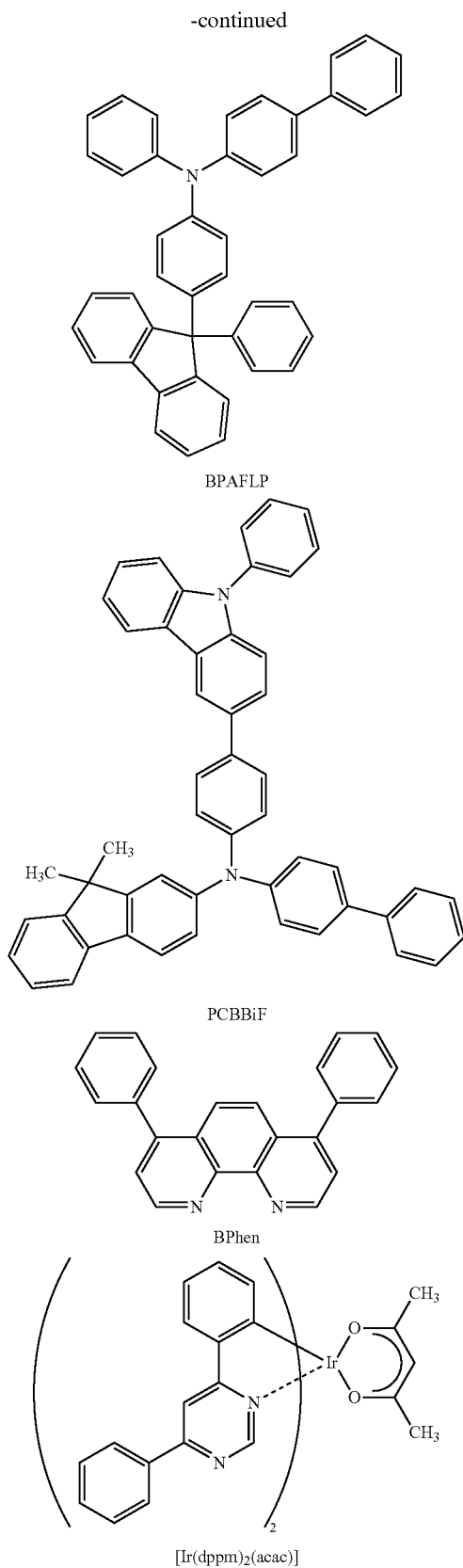

[0272] A method for fabricating a light-emitting element 1 of this example will be described below.

(Light-Emitting Element 1)

[0273] A film of indium tin oxide containing silicon (ITSO) was formed over a glass substrate **1100** by a sputtering method, so that a first electrode **1101** which functions as an anode was formed. The thickness thereof was 110 nm and the electrode area was 2 mm×2 mm.

[0274] Next, as pretreatment for forming the light-emitting element over the glass substrate **1100**, UV-ozone treatment was performed for 370 seconds after washing of a surface of the glass substrate **1100** with water and baking that was performed at 200° C. for 1 hour.

[0275] After that, the glass substrate **1100** was transferred into a vacuum evaporation apparatus where the pressure had been reduced to approximately 10⁻⁴ Pa, and was subjected to vacuum baking at 170° C. for 30 minutes in a heating chamber of the vacuum evaporation apparatus, and then the glass substrate **1100** was cooled down for approximately 30 minutes.

[0276] Then, the glass substrate **1100** over which the first electrode **1101** was formed was fixed to a substrate holder provided in the vacuum evaporation apparatus so that the surface on which the first electrode **1101** was formed faced downward. The pressure in the vacuum evaporation apparatus was reduced to approximately 10⁻⁴ Pa. After that, over the first electrode **1101**, 4,4',4''-(1,3,5-benzenetriyl)tri(dibenzothiophene) (abbreviation: DBT3P-II) and molybdenum(VI) oxide were deposited by co-evaporation, so that a hole-injection layer **1111** was formed. The thickness of the hole-injection layer **1111** was set to 20 nm, and the weight ratio of DBT3P-II to molybdenum oxide was adjusted to 4:2 (=DBT3P-II: molybdenum oxide). Note that the co-evaporation method refers to an evaporation method in which evaporation is carried out from a plurality of evaporation sources at the same time in one treatment chamber.

[0277] Next, a film of 4-phenyl-4'-(9-phenylfluoren-9-yl)triphenylamine (abbreviation: BPAFLP) was formed to a thickness of 20 nm over the hole-injection layer **1111** to form a hole-transport layer **1112**.

[0278] Furthermore, a light-emitting layer **1113** was formed over the hole-transport layer **1112** by co-evaporation of 2mBnBPDBq, N-(1,1'-biphenyl-4-yl)-N-[4-(9-phenyl-9H-carbazol-3-yl)phenyl]-9,9-dimethyl-9H-fluorene-2-amine (abbreviation: PCBBiF), and (acetylacetonato)bis(4,6-diphenylpyrimidinato)iridium(III) (abbreviation: [Ir(dppm)₂(acac)]). Here, a 20-nm-thick layer which was formed with the weight ratio of 2mBnBPDBq to PCBBiF and [Ir(dppm)₂(acac)] adjusted to 0.7:0.3:0.05 (=2mBnBPDBq: PCBBiF: [Ir(dppm)₂(acac)]) and a 20-nm-thick layer which was formed with the weight ratio adjusted to 0.8:0.2:0.05 (=2mBnBPDBq: PCBBiF: [Ir(dppm)₂(acac)]) were stacked.

[0279] Next, a film of 2mBnBPDBq was formed to a thickness of 20 nm over the light-emitting layer **1113** and then a film of bathophenanthroline (abbreviation: BPhen) was formed to a thickness of 10 nm, so that an electron-transport layer **1114** was formed.

[0280] After that, over the electron-transport layer **1114**, a film of lithium fluoride (LiF) was formed by evaporation to a thickness of 1 nm to form an electron-injection layer **1115**.

[0281] Lastly, aluminum was deposited by evaporation to a thickness of 200 nm to form a second electrode **1103** functioning as a cathode. Thus, the light-emitting element 1 of this example was fabricated.

[0282] Note that in all the above evaporation steps, evaporation was performed by a resistance-heating method.

[0283] Table 2 shows the element structure of the light-emitting element fabricated as described above in this example.

where the initial luminance was set to 5000 cd/m² and the current density was constant. FIG. 18 shows that the light-emitting element 1 kept 90% of the initial luminance after 2820 hours. The results of the reliability test show that the light-emitting element 1 has a long lifetime.

TABLE 2

	First electrode	Hole-injection layer	Hole-transport layer	Light-emitting layer	Electron-transport layer	Electron-injection layer	Second electrode		
Light-emitting element 1	ITO 110 nm	DBT3P-II:MoO _x (=4:2) 20 nm	BPAFLP 20 nm	2mBnfBPDBq:PCBBiF: (=0.7:0.3:0.05) 20 nm	[Ir(dppm) ₂ (acac)] (=0.8:0.2:0.05) 20 nm	2mBnfBPDBq 20 nm	BPhen 10 nm	LiF 1 nm	Al 200 nm

[0284] The light-emitting element of this example was sealed in a glove box under a nitrogen atmosphere so as not to be exposed to the air. Then, the operation characteristics of the light-emitting element were measured. Note that the measurement was carried out at room temperature (in an atmosphere kept at 25° C.).

[0285] FIG. 13 shows luminance-current density characteristics of the light-emitting element 1. In FIG. 13, the horizontal axis indicates current density (mA/cm²), and the vertical axis indicates luminance (cd/m²). FIG. 14 shows luminance-voltage characteristics. In FIG. 14, the horizontal axis indicates voltage (V) and the vertical axis indicates luminance (cd/m²). FIG. 15 shows current efficiency-luminance characteristics. In FIG. 15, the horizontal axis indicates luminance (cd/m²) and the vertical axis indicates current efficiency (cd/A). FIG. 16 shows current-voltage characteristics. In FIG. 16, the horizontal axis indicates voltage (V) and the vertical axis indicates current (mA). FIG. 17 shows external quantum efficiency-luminance characteristics. In FIG. 17, the horizontal axis indicates luminance (cd/m²) and the vertical axis indicates external quantum efficiency (%). Table 3 shows the voltage (V), current density (mA/cm²), CIE chromaticity coordinates (x, y), current efficiency (cd/A), power efficiency (lm/W), and external quantum efficiency (%) of the light-emitting element 1 at a luminance of 1000 cd/m².

TABLE 3

	Voltage (V)	Current density (mA/cm ²)	Chromaticity x	Chromaticity y	Luminance (cd/m ²)	Current efficiency (cd/A)	Power efficiency (lm/W)	External quantum efficiency (%)
Light-emitting element 1	3.0	1.3	0.55	0.44	1000	82	86	29

[0286] The CIE chromaticity coordinates (x, y) at a luminance of 1000 cd/m² of the light-emitting element 1 were (0.55, 0.44) and the light-emitting element 1 exhibited orange light emission. These results show that orange light emission originating from [Ir(dppm)₂(acac)] was provided from the light-emitting element 1.

[0287] The measurement results of the operation characteristics show that the light-emitting element 1 has high emission efficiency and a low drive voltage.

[0288] A reliability test of the light-emitting element 1 was conducted. FIG. 18 shows results of the reliability test. In FIG. 18, the vertical axis indicates normalized luminance (%) with an initial luminance of 100% and the horizontal axis indicates driving time (h) of the element. In the reliability test, which was conducted at room temperature, the light-emitting element 1 was driven under the conditions

Example 4

[0289] In this example, the light-emitting element of one embodiment of the present invention will be described with reference to FIG. 12. Chemical formulae of materials used in this example are shown below. Note that the chemical formulae of the materials which are shown above are omitted.

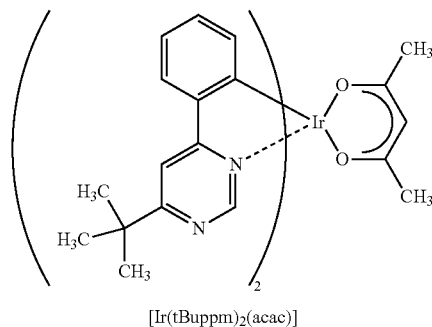

[0290] A method for fabricating a light-emitting element 2 of this example will be described below.

(Light-Emitting Element 2)

[0291] In the light-emitting element 2, components other than the light-emitting layer 1113 and the electron-transport layer 1114 were formed in a similar manner to the light-emitting element 1. Here, only different steps from the method for fabricating the light-emitting element 1 are described.

[0292] The light-emitting layer 1113 of the light-emitting element 2 was formed by co-depositing 2mBnfBPDBq, PCBBiF, and (acetylacetonato)bis(6-tert-butyl-4-phenylpyrimidinato)iridium(III) (abbreviation: [Ir(tBuppm)₂(acac)]) by evaporation. Here, a 20-nm-thick layer which was

formed with the weight ratio of 2mBnfBPDBq to PCBBiF and $[\text{Ir}(\text{tBuppm})_2(\text{acac})]$ adjusted to 0.7:0.3:0.05 (=2mBnfBPDBq: PCBBiF: $[\text{Ir}(\text{tBuppm})_2(\text{acac})]$) and a 20-nm-thick layer which was formed with the weight ratio adjusted to 0.8:0.2:0.05 (=2mBnfBPDBq: PCBBiF: $[\text{Ir}(\text{tBuppm})_2(\text{acac})]$) were stacked.

[0293] The electron-transport layer 1114 of the light-emitting element 2 was formed by depositing 2mBnfBPDBq to a thickness of 15 nm and further depositing BPhen to a thickness of 10 nm.

[0294] Table 4 shows the element structure of the light-emitting element fabricated as described above in this example.

[0297] The CIE chromaticity coordinates (x, y) at a luminance of 700 cd/m^2 of the light-emitting element 2 were (0.40, 0.59) and the light-emitting element 2 exhibited yellow green light emission. These results show that yellow green light emission originating from $[\text{Ir}(\text{tBuppm})_2(\text{acac})]$ was provided from the light-emitting element 2.

[0298] The measurement results of the operation characteristics show that the light-emitting element 2 has high emission efficiency and a low drive voltage.

[0299] A reliability test of the light-emitting element 2 was conducted. FIG. 24 shows results of the reliability test. In FIG. 24, the vertical axis indicates normalized luminance (%) with an initial luminance of 100% and the horizontal axis indicates driving time (h) of the element. In the reli-

TABLE 4

	First electrode	Hole-injection layer	Hole-transport layer	Light-emitting layer	Electron-transport layer		Electron-injection layer	Second electrode
Light-emitting element 2	ITO 110 nm	DBT3P-II:MoO _x (=4:2) 20 nm	BPAFLP 20 nm	2mBnfBPDBq:PCBBiF: $[\text{Ir}(\text{tBuppm})_2(\text{acac})]$ (=0.7:0.3:0.05) 20 nm	2mBnfBPDBq 15 nm	BPhen 10 nm	LiF 1 nm	Al 200 nm

[0295] The light-emitting element of this example was sealed in a glove box under a nitrogen atmosphere so as not to be exposed to the air. Then, the operation characteristics of the light-emitting element were measured. Note that the measurement was carried out at room temperature (in an atmosphere kept at 25° C.).

[0296] FIG. 19 shows luminance-current density characteristics of the light-emitting element 2. In FIG. 19, the horizontal axis indicates current density (mA/cm^2), and the vertical axis indicates luminance (cd/m^2). FIG. 20 shows luminance-voltage characteristics. In FIG. 20, the horizontal axis indicates voltage (V) and the vertical axis indicates luminance (cd/m^2). FIG. 21 shows current efficiency-luminance characteristics. In FIG. 21, the horizontal axis indicates luminance (cd/m^2) and the vertical axis indicates current efficiency (cd/A). FIG. 22 shows current-voltage characteristics. In FIG. 22, the horizontal axis indicates voltage (V) and the vertical axis indicates current (mA). FIG. 23 shows external quantum efficiency-luminance characteristics. In FIG. 23, the horizontal axis indicates luminance (cd/m^2) and the vertical axis indicates external quantum efficiency (%). Table 5 shows the voltage (V), current density (mA/cm^2), CIE chromaticity coordinates (x, y), current efficiency (cd/A), power efficiency (lm/W), and external quantum efficiency (%) of the light-emitting element 2 at a luminance of 700 cd/m^2 .

ability test, which was conducted at room temperature, the light-emitting element 2 was driven under the conditions where the initial luminance was set to 5000 cd/m^2 and the current density was constant. FIG. 24 shows that the light-emitting element 2 kept 86% of the initial luminance after 810 hours. The results of the reliability test show that the light-emitting element 2 has a long lifetime.

Example 5

Synthesis Example 2

[0300] This example describes a method for synthesizing 2-[3'-(6-phenylbenzo[b]naphtho[1,2-d]furan-8-yl)biphenyl-3-yl]dibenzo[f,h]quinoxaline (abbreviation: 2mBnfBPDBq-02) represented by Structural Formula (140).

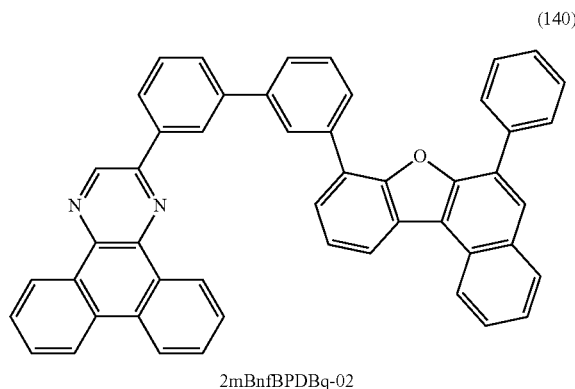
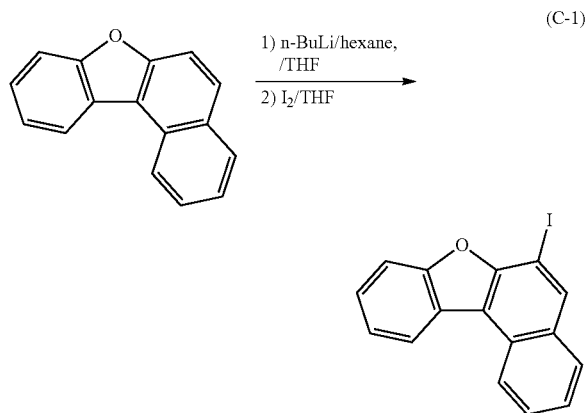

TABLE 5

	Voltage (V)	Current density (mA/cm^2)	Chromaticity x	Chromaticity y	Luminance (cd/m^2)	Current efficiency (cd/A)	Power efficiency (lm/W)	External quantum efficiency (%)
Light-emitting element 2	2.7	0.72	0.40	0.59	700	97	113	25

Step 1-1: Synthesis of
6-Iodobenzo[b]naphtho[1,2-d]furan

[0301] A synthesis scheme of Step 1-1 is shown in (C-1).



[0302] Into a 500 mL three-neck flask was put 8.5 g (39 mmol) of benzo[b]naphtho[1,2-d]furan, and the air in the flask was replaced with nitrogen. Then, 195 mL of tetrahydrofuran (THF) was added thereto. This solution was cooled to -75°C . Then, 25 mL (40 mmol) of n-butyllithium (a 1.59 mol/L n-hexane solution) was dropped into this solution. After the drop, the resulting solution was stirred at room temperature for 1 hour. After the stirring, the resulting solution was cooled to -75°C . Into this solution, a solution in which 10 g (40 mmol) of iodine was dissolved in 40 mL of THF was dropped. After the drop, the resulting solution was stirred for 17 hours while the temperature of the solution was returned to room temperature. After the stirring, an aqueous solution of sodium thiosulfate was added to the mixture, and the resulting mixture was stirred for 1 hour. Then, the organic layer of the mixture was washed with water and dried with magnesium sulfate. After the drying, the mixture was gravity-filtered to give a solution. The resulting solution was suction-filtered through Celite (Catalog No. 531-16855 produced by Wako Pure Chemical Industries, Ltd., the same applies to Celite described below and a repetitive description thereof is omitted) and Florisil (Catalog No. 540-00135 produced by Wako Pure Chemical Industries, Ltd., the same applies to Florisil described below and a repetitive description thereof is omitted) to give a filtrate. The resulting filtrate was concentrated to give a solid. The resulting solid was recrystallized from toluene to give 6.0 g (18 mmol) of white powder of the target substance in a yield of 45%.

Step 1-2: Synthesis of
6-Phenylbenzo[b]naphtho[1,2-d]furan

[0303] A synthesis scheme of Step 1-2 is shown in (C-2).

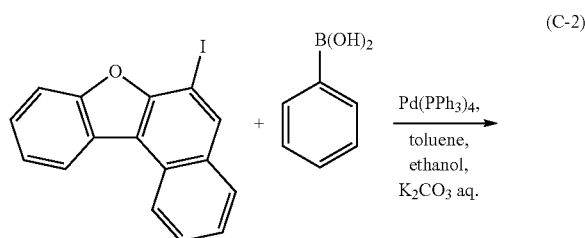

-continued

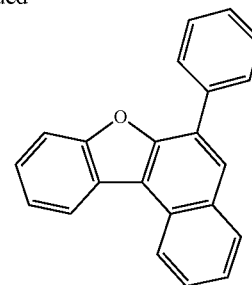

[0304] Into a 200 mL three-neck flask were put 6.0 g (18 mmol) of 6-iodobenzo[b]naphtho[1,2-d]furan, 2.4 g (19 mmol) of phenylboronic acid, 70 mL of toluene, 20 mL of ethanol, and 22 mL of an aqueous solution of potassium carbonate (2.0 mol/L). This mixture was degassed by being stirred while the pressure was reduced. After the degassing, the air in the flask was replaced with nitrogen, and then 480 mg (0.42 mmol) of tetrakis(triphenylphosphine)palladium (0) was added to the mixture. The resulting mixture was stirred at 90°C . under a nitrogen stream for 12 hours. After the stirring, water was added to the mixture, and the aqueous layer was subjected to extraction with toluene. The solution of the extract combined with the organic layer was washed with water and then dried with magnesium sulfate. The mixture was gravity-filtered to give a filtrate. The resulting filtrate was concentrated to give a solid, and the resulting solid was dissolved in toluene. The resulting solution was suction-filtered through Celite, Florisil, and alumina to give a filtrate. The resulting filtrate was concentrated to give a solid. The resulting solid was recrystallized from toluene to give 4.9 g (17 mmol) of a white solid of the target substance in a yield of 93%.

Step 1-3: Synthesis of
8-Iodo-6-phenylbenzo[b]naphtho[1,2-d]furan

[0305] A synthesis scheme of Step 1-3 is shown in (C-3).

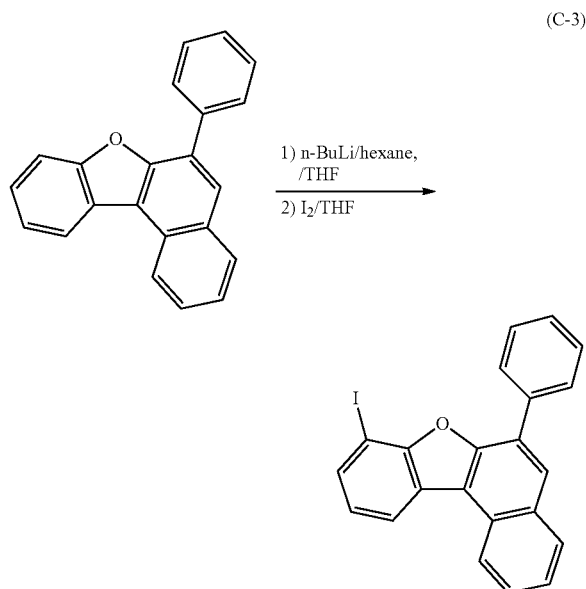

[0306] Into a 300 mL three-neck flask was put 4.9 g (17 mmol) of 6-phenylbenzo[b]naphtho[1,2-d]furan, and the air in the flask was replaced with nitrogen. Then, 87 mL of THF was added thereto. The resulting solution was cooled to -75°C . Then, 11 mL (18 mmol) of *n*-butyllithium (a 1.59 mol/L *n*-hexane solution) was dropped into the solution. After the drop, the resulting solution was stirred at room temperature for 1 hour. After the stirring, the resulting solution was cooled to -75°C . Then, a solution in which 4.6 g (18 mmol) of iodine was dissolved in 18 mL of THF was dropped into the resulting solution. The resulting solution was stirred for 17 hours while the temperature of the solution was returned to room temperature. After the stirring, an aqueous solution of sodium thiosulfate was added to the mixture, and the resulting mixture was stirred for 1 hour. Then, the organic layer of the mixture was washed with water and dried with magnesium sulfate. The mixture was gravity-filtered to give a filtrate. The resulting filtrate was suction-filtered through Celite, Florisil, and alumina to give a filtrate. The resulting filtrate was concentrated to give a solid. The resulting solid was recrystallized from toluene to give 3.7 g (8.8 mmol) of a target white solid in a yield of 53%.

Step 2: Synthesis of 2-[3'-(Dibenzo[f,h]quinoxalin-2-yl)-biphenyl-3-yl]-4,4, 5,5-tetramethyl-1,3,2-dioxaborolane

[0307] A synthesis scheme of Step 2 is shown in (C-4).

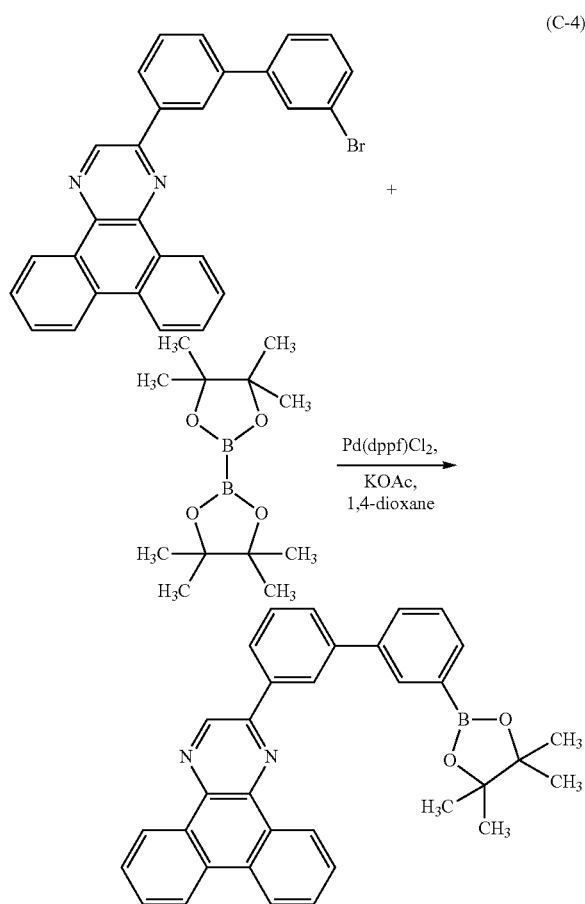

[0308] Into a 200 mL three-neck flask were put 1.8 g (3.9 mmol) of 2-(3'-bromobiphenyl-3-yl)dibenzo[f,h]quinoxaline, 994 mg (3.9 mmol) of bis(pinacolato)diboron, and 795 mg (8.0 mmol) of potassium acetate, and the air in the flask was replaced with nitrogen. To this mixture, 20 mL of 1,4-dioxane was added, and the obtained mixture was degassed by being stirred under reduced pressure; then, the air in the flask was replaced with a nitrogen stream. The obtained mixture was stirred at 60°C ., and to this mixture, 87 mg (0.1 mmol) of [1,1'-bis(diphenylphosphino)ferrocene]palladium(II) dichloride dichloromethane adduct was added. This mixture was stirred at 80°C . for 9 hours. The reaction mixture was developed by silica gel thin layer chromatography (developing solvent: a mixed solvent of hexane:ethyl acetate=10:1), so that a spot of the objective substance was observed.

Step 3: Synthesis of 2mBnfBPDBq-02

[0309] A synthesis scheme of Step 3 is shown in (C-5).

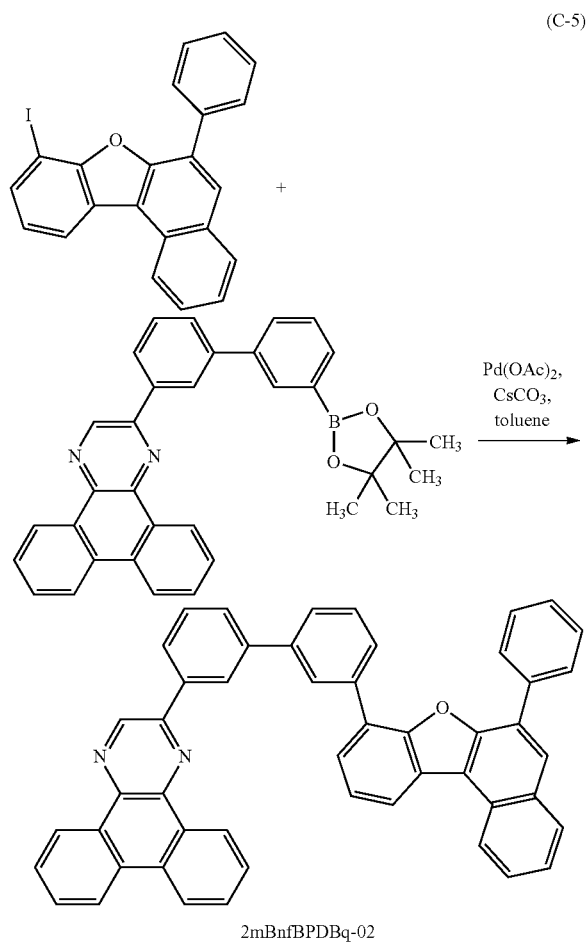

[0310] After the reaction by Step 2, the reaction by Step 3 was carried out in the same container without work-up (posttreatment). To the mixture obtained in Step 2, 1.6 g (3.9 mmol) of 8-iodo-6-phenylbenzo[b]naphtho[1,2-d]furan obtained in Step 1-3, 60 mg (0.30 mmol) of palladium(II) acetate, and 2.2 g (6.6 mmol) of cesium carbonate were added, and this mixture was stirred at 100°C . for 6 hours.

After 20 mL of xylene was added to this mixture, stirring was performed at 120° C. for 9 hours. After the stirring, a precipitated solid was collected by suction filtration and washed with water and ethanol in this order, and a resulting solid was dried; thus, 1.7 g of a target brown solid was produced in a yield of 65%.

[0311] By a train sublimation method, 1.5 g of the obtained solid was purified. The sublimation purification was conducted under the conditions where the pressure was 3.2 Pa, the flow rate of an argon gas was 15 mL/min, and the solid was heated at 350° C. for 17 hours. After the heating, 0.95 g of a pale brown solid was obtained at a collection rate of 63%.

[0312] Then, 0.95 g of the solid obtained by the sublimation purification was purified by a train sublimation method. The sublimation purification was conducted under the conditions where the pressure was 3.5 Pa, the flow rate of an argon gas was 15 mL/min, and the solid was heated at 350° C. for 17 hours. After the heating, 0.72 g of a pale brown solid was obtained at a collection rate of 77%.

[0313] This compound was identified as 2mBnfBPDBq-02, which was the target substance, by nuclear magnetic resonance (NMR) spectroscopy.

[0314] ¹H NMR data of the obtained substance are as follows:

[0315] ¹H NMR (tetrachloroethane-d₂, 500 MHz): δ=7.28-7.29 (m, 3H), 7.62 (t, J=7.5 Hz, 1H), 7.65-7.73 (m, 4H), 7.77-7.86 (m, 7H), 7.98-8.00 (m, 2H), 8.03 (d, 1H), 8.07 (s, 1H), 8.10 (d, 1H), 8.38 (d, J=8.0 Hz, 1H), 8.49-8.51 (m, 2H), 8.65-8.66 (m, 3H), 8.72 (d, J=8.5 Hz, 1H), 9.27 (d, J=7.0 Hz, 1H), 9.40 (d, J=8.0 Hz, 1H), 9.44 (s, 1H).

[0316] In addition, FIGS. 25A and 25B show ¹H NMR charts. Note that FIG. 25B is a chart showing an enlarged part of FIG. 25A in the range of 7.00 ppm to 10.0 ppm.

[0317] Furthermore, FIG. 26A shows an absorption spectrum of a toluene solution of 2mBnfBPDBq-02, and FIG. 26B shows an emission spectrum thereof. FIG. 27A shows an absorption spectrum of a thin film of 2mBnfBPDBq-02 and FIG. 27B shows an emission spectrum thereof. For the measurement method and measurement conditions of the absorption spectra, refer to the description in Example 1. In FIGS. 26A and 26B and FIGS. 27A and 27B, the horizontal axis indicates wavelength (nm) and the vertical axis indicates intensity (arbitrary unit). In the case of the toluene solution, absorption peaks are observed around 322 nm, 353 nm, and 375 nm, and emission wavelength peaks are observed at 385 nm and 405 nm (excitation wavelength: 330 nm). In the case of the thin film, absorption peaks are observed around 262 nm, 328 nm, 345 nm, 366 nm, and 383 nm, and an emission wavelength peak is observed at 439 nm (excitation wavelength: 380 nm).

[0318] Electrochemical characteristics of a 2mBnfBPDBq-02 solution were also measured.

[0319] For the measurement method, measurement conditions, and the like, refer to the description in Example 1.

[0320] For the measurement of the oxidation characteristics, the potential of the working electrode with respect to the reference electrode was scanned from 0.30 V to 1.30 V and then from 1.30 V to 0.30 V. An observed oxidation peak had 59% of the initial intensity even after 100 cycles. This indicates that 2mBnfBPDBq-02 has properties effective against repetition of redox reactions between an oxidized state and a neutral state. FIG. 28A shows the measurement results of the oxidation characteristics.

[0321] For the measurement of the reduction characteristics, the potential of the working electrode with respect to the reference electrode was scanned from -1.30 V to -2.10

V and then from -2.10 V to -1.30 V. An observed reduction peak had 78% of the initial intensity even after 100 cycles. This indicates that 2mBnfBPDBq-02 has properties effective against repetition of redox reactions between a reduced state and a neutral state. FIG. 28B shows the measurement results of the reduction characteristics.

[0322] On the assumption that the intermediate potential (the half-wave potential) between the oxidation peak potential E_{pa} and the reduction peak potential E_{pc} which are obtained in the CV measurement corresponds to the HOMO level, the HOMO level of 2mBnfBPDBq-02 was calculated to be -6.06 eV, and the LUMO level of 2mBnfBPDBq-02 was calculated to be -2.94 eV. Accordingly, the band gap (ΔE) of 2mBnfBPDBq-02 was found to be 3.12 eV.

[0323] Furthermore, 2mBnfBPDBq-02 was subjected to thermogravimetry-differential thermal analysis. For the measurement method, measurement conditions, and the like, refer to the description in Example 1. Measurement results show that the 5% weight loss temperature of 2mBnfBPDBq-02 was 500° C. or higher and the melting point thereof was 273° C. Accordingly, it was shown that 2mBnfBPDBq-02 has high heat resistance.

[0324] Furthermore, 2mBnfBPDBq-02 was subjected to MS analysis by LC-MS.

[0325] Description of analysis conditions similar to those in Example 1 is omitted. In the analysis by LC-MS in this example, acetonitrile was used for Mobile Phase A and a 0.1% aqueous solution of formic acid was used for Mobile Phase B. Analysis was performed by a gradient method for 10 minutes, in which the proportion of acetonitrile was 75% at the start of the analysis, kept at the value for 1 minute, and then increased linearly to reach 95% after 10 minutes from the start of the analysis.

[0326] In the MS analysis in this example, the resolution was 35000, the AGC target was 2e5, the mass range was $m/z=50.00$ to 705.00, and the detection was performed in a positive mode.

[0327] A component with m/z of 674.24±10 ppm that underwent the ionization under the above-described conditions was collided with an argon gas in a collision cell to dissociate into product ions, and MS/MS measurement was carried out. Ions which were generated under an NCE for the collision with argon of 50 were detected with a Fourier transform mass spectrometer (FT MS). FIGS. 35A and 35B show the results.

[0328] The results in FIGS. 35A and 35B demonstrate that product ions of 2mBnfBPDBq-02 are detected around $m/z=229$ and $m/z=220$. Note that the results in FIGS. 35A and 35B show characteristics derived from 2mBnfBPDBq-02 and thus can be regarded as important data for identifying 2mBnfBPDBq-02 contained in a mixture.

[0329] The product ion around $m/z=229$ is presumed to be a cation derived from dibenzo[f,h]quinoxaline in 2mBnfBPDBq-02, and indicates a partial structure of the heterocyclic compound of one embodiment of the present invention. The product ion around $m/z=220$ is presumed to be a cation that was derived from an alcohol formed by cleavage of an ether linkage in benzo[b]naphtho[1,2-d]furan (Structural Formula (10) or Structural Formula (11) in Example 1), and indicates a partial structure of the heterocyclic compound of one embodiment of the present invention.

[0330] Phosphorescence of 2mBnfBPDBq-02 was measured.

[0331] In this example, an evaporated film of 2mBnfBPDBq-02 was formed and was subjected to a low-temperature

PL method, and the T_1 level thereof was estimated from the measured phosphorescence spectrum. Note that the T_1 level was estimated from a peak wavelength on the shortest wavelength side of the phosphorescence spectrum. The measurement was performed by using a PL microscope, LabRAM HR-PL, produced by HORIBA, Ltd., a He—Cd

DBq-02 to a thickness of 20 nm and further depositing BPhen to a thickness of 10 nm.

[0339] Table 6 shows the element structure of the light-emitting element fabricated as described above in this example.

TABLE 6

	First electrode	Hole-injection layer	Hole-transport layer	Light-emitting layer		Electron-transport layer	Electron-injection layer	Second electrode
Light-emitting element 3	ITO 110 nm	DBT3P-II:MoO _x (=4:2) 20 nm	BPAFLP 20 nm	2mBnfBPDBq-02:PCBBiF: (=0.7:0.3:0.05) 20 nm	[Ir(dppm) ₂ (acac)] (=0.8:0.2:0.05) 20 nm	2mBnfBPDBq-02 20 nm	BPhen 10 nm LiF 1 nm	Al 200 nm

laser (325 nm) as excitation light, and a CCD detector at a measurement temperature of 10 K.

[0332] For the measurement, a thin film was formed over a quartz substrate to a thickness of 50 nm and another quartz substrate was attached to the deposition surface in a nitrogen atmosphere.

[0333] According to the measurement results, a peak wavelength on the shortest wavelength side of the phosphorescence spectrum was 545 nm. Thus, the T_1 level of 2mBnfBPDBq-02 was calculated to be 2.28 eV.

Example 6

[0334] In this example, the light-emitting element of one embodiment of the present invention will be described with reference to FIG. 12.

[0335] A method for fabricating a light-emitting element 3 of this example will be described below.

(Light-Emitting Element 3)

[0336] In the light-emitting element 3, components other than the light-emitting layer 1113 and the electron-transport layer 1114 were formed in a similar manner to the light-

[0340] The light-emitting element of this example was sealed in a glove box under a nitrogen atmosphere so as not to be exposed to the air. Then, the operation characteristics of the light-emitting element were measured. Note that the measurement was carried out at room temperature (in an atmosphere kept at 25° C.).

[0341] FIG. 29 shows luminance-current density characteristics of the light-emitting element 3. In FIG. 29, the horizontal axis indicates current density (mA/cm²), and the vertical axis indicates luminance (cd/m²). FIG. 30 shows luminance-voltage characteristics. In FIG. 30, the horizontal axis indicates voltage (V) and the vertical axis indicates luminance (cd/m²). FIG. 31 shows current efficiency-luminance characteristics. In FIG. 31, the horizontal axis indicates luminance (cd/m²) and the vertical axis indicates current efficiency (cd/A). FIG. 32 shows current-voltage characteristics. In FIG. 32, the horizontal axis indicates voltage (V) and the vertical axis indicates current (mA). FIG. 33 shows external quantum efficiency-luminance characteristics. In FIG. 33, the horizontal axis indicates luminance (cd/m²) and the vertical axis indicates external quantum efficiency (%). Table 7 shows the voltage (V), current density (mA/cm²), CIE chromaticity coordinates (x, y), current efficiency (cd/A), power efficiency (lm/W), and external quantum efficiency (%) of the light-emitting element 3 at a luminance of 1200 cd/m².

TABLE 7

	Voltage (V)	Current density (mA/cm ²)	Chromaticity x	Chromaticity y	Luminance (cd/m ²)	Current efficiency (cd/A)	Power efficiency (lm/W)	External quantum efficiency (%)
Light-emitting element 3	2.9	1.4	0.55	0.44	1200	82	89	30

emitting element 1. Here, only different steps from the method for fabricating the light-emitting element 1 are described.

[0337] The light-emitting layer 1113 of the light-emitting element 3 was formed by co-depositing 2mBnfBPDBq-02, PCBBiF, and [Ir(dppm)₂(acac)] by evaporation. Here, a 20-nm-thick layer which was formed with the weight ratio of 2mBnfBPDBq-02 to PCBBiF and [Ir(dppm)₂(acac)] adjusted to 0.7:0.3:0.05 (=2mBnfBPDBq-02:PCBBiF:[Ir(dppm)₂(acac)]) and a 20-nm-thick layer which was formed with the weight ratio adjusted to 0.8:0.2:0.05 (=2mBnfBPDBq-02:PCBBiF:[Ir(dppm)₂(acac)]) were stacked.

[0338] The electron-transport layer 1114 of the light-emitting element 3 was formed by depositing 2mBnfBP-

[0342] The CIE chromaticity coordinates (x, y) at a luminance of 1200 cd/m² of the light-emitting element 3 were (0.55, 0.44) and the light-emitting element 3 exhibited orange light emission. These results show that orange light emission originating from [Ir(dppm)₂(acac)] was provided from the light-emitting element 3.

[0343] The measurement results of the operation characteristics show that the light-emitting element 3 has high emission efficiency and a low drive voltage.

[0344] A reliability test of the light-emitting element 3 was conducted. FIG. 34 shows results of the reliability test. In FIG. 34, the vertical axis indicates normalized luminance (%) with an initial luminance of 100% and the horizontal

axis indicates driving time (h) of the element. In the reliability test, which was conducted at room temperature, the light-emitting element 3 was driven under the conditions where the initial luminance was set to 5000 cd/m² and the current density was constant. FIG. 34 shows that the light-emitting element 3 kept 87% of the initial luminance after 1100 hours. The results of the reliability test show that the light-emitting element 3 has a long lifetime.

Reference Example

[0345] A method for synthesizing N-(1,1'-biphenyl-4-yl)-N-[4-(9-phenyl-9H-carbazol-3-yl)phenyl]-9,9-dimethyl-9H-fluoren-2-amine (abbreviation: PCBBiF) used in Examples 3 and 4 will be described.

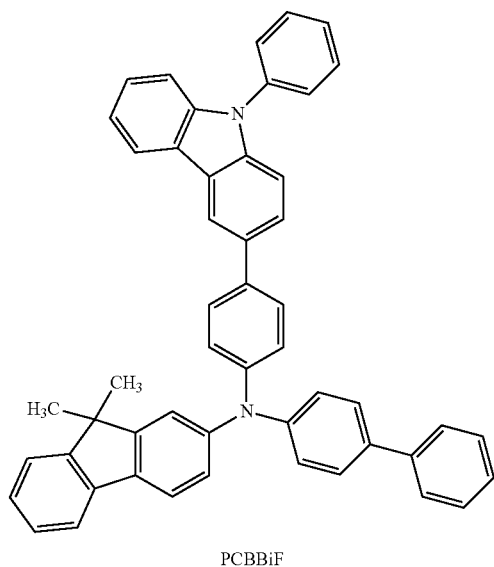

Step 1: Synthesis of N-(1,1'-Biphenyl-4-yl)-9,9-dimethyl-N-phenyl-9H-fluoren-2-amine>

[0346] A synthesis scheme of Step 1 is shown in (x-1).

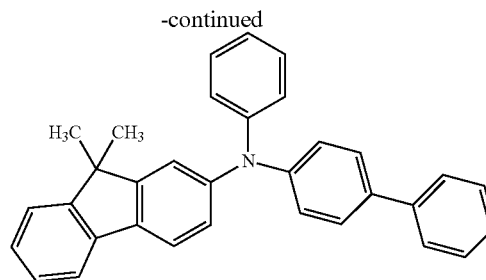
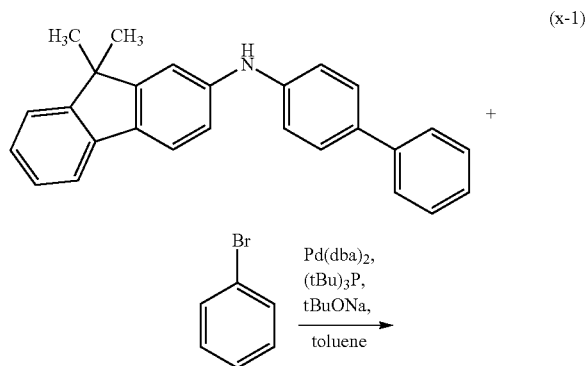

[0347] In a 1 L three-neck flask were placed 45 g (0.13 mol) of N-(1,1'-biphenyl-4-yl)-9,9-dimethyl-9H-fluoren-2-amine, 36 g (0.38 mol) of sodium tert-butoxide, 21 g (0.13 mol) of bromobenzene, and 500 mL of toluene. The mixture was degassed by being stirred while the pressure was reduced, and after the degassing, the air in the flask was replaced with nitrogen. Then, 0.8 g (1.4 mmol) of bis(dibenzylideneacetone)palladium(0) and 12 mL (5.9 mmol) of tri(tert-butyl)phosphine (a 10 wt % hexane solution) were added.

[0348] The mixture was stirred at 90° C. under a nitrogen stream for 2 hours. Then, the mixture was cooled to room temperature, and a solid was separated by suction filtration. The obtained filtrate was concentrated to give approximately 200 mL of a brown liquid. The brown liquid was mixed with toluene, and the resulting solution was purified using Celite, alumina, and Florisil. The resulting filtrate was concentrated to give a pale yellow liquid. The pale yellow liquid was recrystallized from hexane to give 52 g of target pale yellow powder in a yield of 95%.

Step 2: Synthesis of N-(1,1'-Biphenyl-4-yl)-N-(4-bromophenyl)-9,9-dimethyl-9H-fluoren-2-amine

[0349] A synthesis scheme of Step 2 is shown in (x-2).

(x-2)

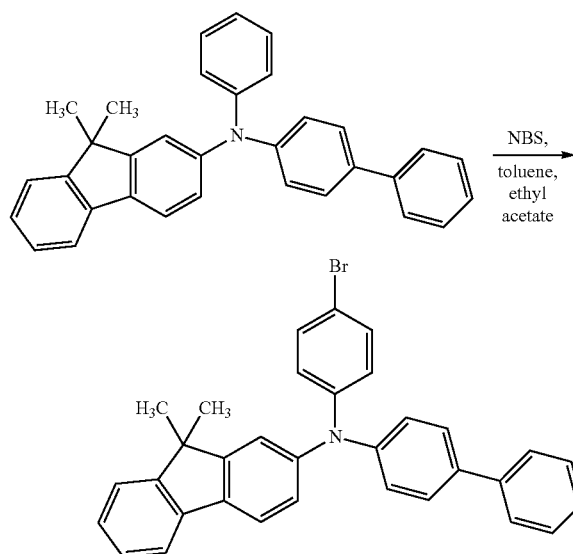

[0350] In a 1 L Erlenmeyer flask was placed 45 g (0.10 mol) of N-(1,1'-biphenyl-4-yl)-9,9-dimethyl-N-phenyl-9H-fluoren-2-amine, which was dissolved in 225 mL of toluene by stirring while being heated. After the solution was naturally cooled to room temperature, 225 mL of ethyl

acetate and 18 g (0.10 mol) of N-bromosuccinimide (abbreviation: NBS) were added, and the mixture was stirred at room temperature for 2.5 hours. After the stirring, the mixture was washed three times with a saturated aqueous solution of sodium hydrogen carbonate and once with saturated brine. Magnesium sulfate was added to the resulting organic layer, and the mixture was left standing for 2 hours for drying. The mixture was subjected to gravity filtration to remove magnesium sulfate, and the resulting filtrate was concentrated to give a yellow liquid. The yellow liquid was mixed with toluene, and this solution was purified using Celite, alumina, and Florisil. The resulting solution was concentrated to give a pale yellow solid. The pale yellow solid was recrystallized from toluene/ethanol to give 47 g of target white powder in a yield of 89%.

Step 3: Synthesis of PCBBiF

[0351] A synthesis scheme of Step 3 is shown in (x-3).

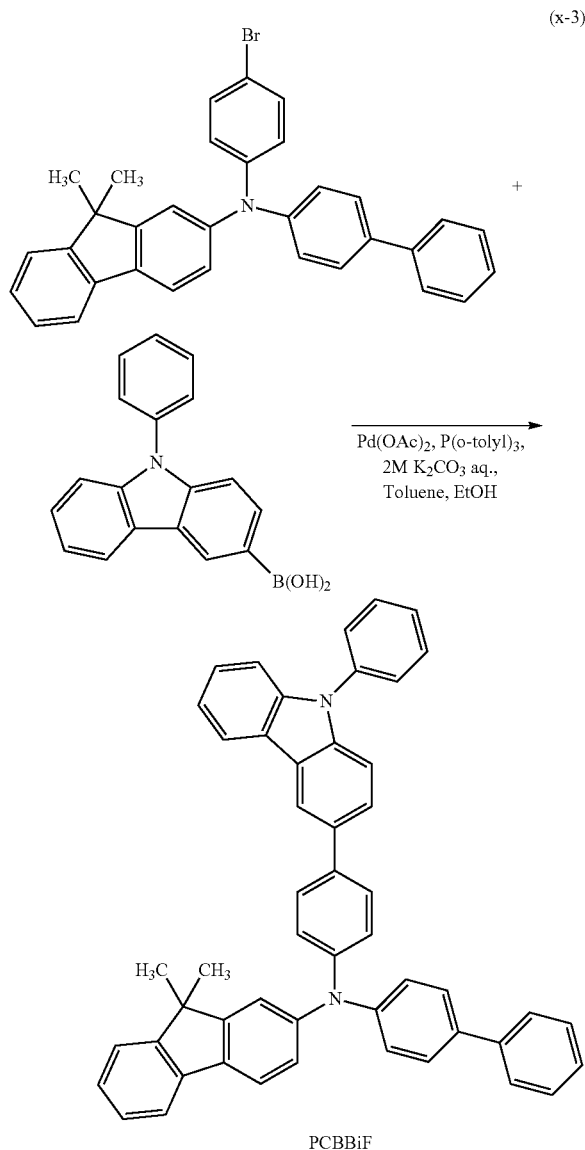

[0352] In a 1 L three-neck flask were placed 41 g (80 mmol) of N-(1,1'-biphenyl-4-yl)-N-(4-bromophenyl)-9,9-dimethyl-9H-fluoren-2-amine and 25 g (88 mmol) of 9-phenyl-9H-carbazole-3-boronic acid, to which 240 mL of toluene, 80 mL of ethanol, and 120 mL of an aqueous solution of potassium carbonate (2.0 mol/L) were added. The mixture was degassed by being stirred while the pressure was reduced, and after the degassing, the air in the flask was replaced with nitrogen. Furthermore, 27 mg (0.12 mmol) of palladium(II) acetate and 154 mg (0.5 mmol) of tri(ortho-tolyl)phosphine were added. The mixture was degassed again by being stirred while the pressure was reduced, and after the degassing, the air in the flask was replaced with nitrogen. The mixture was stirred at 110° C. under a nitrogen stream for 1.5 hours.

[0353] After the mixture was naturally cooled to room temperature while being stirred, the aqueous layer of the mixture was subjected to extraction twice with toluene. The resulting solution of the extract and the organic layer were combined and washed twice with water and twice with saturated brine. Magnesium sulfate was added to the solution, and the mixture was left standing for drying. The mixture was subjected to gravity filtration to remove magnesium sulfate, and the resulting filtrate was concentrated to give a brown solution. The brown solution was mixed with toluene, and the resulting solution was purified using Celite, alumina, and Florisil. The resulting filtrate was concentrated to give a pale yellow solid. The pale yellow solid was recrystallized from ethyl acetate/ethanol to give 46 g of target pale yellow powder in a yield of 88%.

[0354] By a train sublimation method, 38 g of the obtained pale yellow powder was purified. In the sublimation purification, the pale yellow powder was heated at 345° C. under a pressure of 3.7 Pa with an argon flow rate of 15 mL/min. After the sublimation purification, 31 g of a target pale yellow solid was obtained at a collection rate of 83%.

[0355] This compound was identified as N-(1,1'-biphenyl-4-yl)-N-[4-(9-phenyl-9H-carbazol-3-yl)phenyl]-9,9-dimethyl-9H-fluoren-2-amine (abbreviation: PCBBiF), which was the target of the synthesis, by nuclear magnetic resonance (NMR) spectroscopy.

[0356] ^1H NMR data of the obtained pale yellow solid are as follows:

[0357] ^1H NMR (CDCl_3 , 500 MHz): δ =1.45 (s, 6H), 7.18 (d, J =8.0 Hz, 1H), 7.27-7.32 (m, 8H), 7.40-7.50 (m, 7H), 7.52-7.53 (m, 2H), 7.59-7.68 (m, 12H), 8.19 (d, J =8.0 Hz, 1H), 8.36 (d, J =1.1 Hz, 1H).

REFERENCE NUMERALS

[0358] 201: first electrode, 203: EL layer, 203a: first EL layer, 203b: second EL layer, 205: second electrode, 207: intermediate layer, 301: hole-injection layer, 302: hole-transport layer, 303: light-emitting layer, 304: electron-transport layer, 305: electron-injection layer, 401: support substrate, 403: light-emitting element, 405: sealing substrate, 407: sealing material, 409a: first terminal, 409b: second terminal, 411a: light extraction structure, 411b: light extraction structure, 413: planarization layer, 415: space, 417: auxiliary wiring, 419: insulating layer, 421: first electrode, 423: EL layer, 425: second electrode, 501: support substrate, 503: light-emitting element, 504: light-emitting element, 505: sealing substrate, 506: desiccant, 507: sealing material, 509: FPC, 511: insulating layer, 513: insulating layer, 515: space, 517: wiring, 519: partition, 521: first

electrode, **523**: EL layer, **525**: second electrode, **531**: black matrix, **533**: color filter, **535**: overcoat layer, **541a**: transistor, **541b**: transistor, **542**: transistor, **543**: transistor, **551**: light-emitting portion, **551a**: light-emitting portion, **551b**: light-emitting portion, **552**: driver circuit portion, **553**: driver circuit portion, **561**: first electrode, **563**: EL layer, **565**: second electrode, **1100**: glass substrate, **1101**: first electrode, **1103**: second electrode, **1111**: hole-injection layer, **1112**: hole-transport layer, **1113**: light-emitting layer, **1114**: electron-transport layer, **1115**: electron-injection layer, **7100**: television device, **7101**: housing, **7102**: display portion, **7103**: stand, **7111**: remote controller, **7200**: computer, **7201**: main body, **7202**: housing, **7203**: display portion, **7204**: keyboard, **7205**: external connection port, **7206**: pointing device, **7300**: portable game machine, **7301a**: housing, **7301b**: housing, **7302**: joint portion, **7303a**: display portion, **7303b**: display portion, **7304**: speaker portion, **7305**: recording medium insertion portion, **7306**: operation key, **7307**: connection terminal, **7308**: sensor, **7400**: cellular phone, **7401**: housing, **7402**: display portion, **7403**: operation button, **7404**: external connection port, **7405**: speaker, **7406**: microphone, **7500**: tablet terminal, **7501a**: housing, **7501b**: housing, **7502a**: display portion, **7502b**: display portion, **7503**: hinge, **7504**: power switch, **7505**: operation key, **7506**: speaker, **7601**: lighting device, **7602**: lighting device, **7603**: desk lamp, **7604**: planar lighting device, **7701**: lighting portion, **7703**: support, **7705**: support base.

[0359] This application is based on Japanese Patent Application serial no. 2013-178449 filed with Japan Patent Office on Aug. 29, 2013, and Japanese Patent Application serial no. 2014-095259 filed with Japan Patent Office on May 2, 2014, the entire contents of which are hereby incorporated by reference.

1. A compound represented by formula (G4):

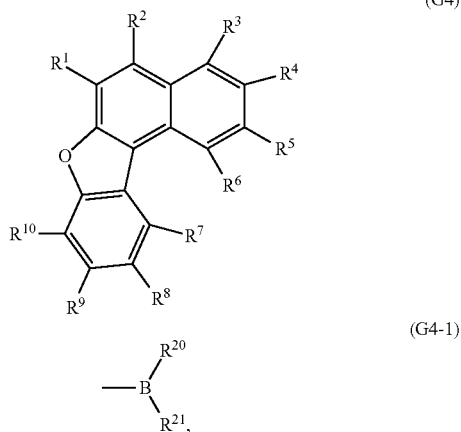

wherein:

one of R⁷ to R¹⁰ represents a substituent represented by formula (G4-1);

R¹ to R⁶ and the others of R⁷ to R¹⁰ separately represent any one of hydrogen, an alkyl group having 1 to 6 carbon atoms, a cycloalkyl group having 3 to 6 carbon atoms, and an aryl group having 6 to 13 carbon atoms;

R²⁰ and R²¹ separately represent an alkoxy group having 1 to 6 carbon atoms and are bonded to each other to form a ring.

2. The compound according to claim 1, wherein the aryl group having 6 to 13 carbon atoms is unsubstituted or substituted by any one of an alkyl group having 1 to 6 carbon atoms, a cycloalkyl group having 3 to 6 carbon atoms, and an aryl group having 6 to 13 carbon atoms.

3. The compound according to claim 1, wherein the alkoxy group having 1 to 6 carbon atoms is unsubstituted or substituted by any one of an alkyl group having 1 to 6 carbon atoms, a cycloalkyl group having 3 to 6 carbon atoms, and an aryl group having 6 to 13 carbon atoms.

4. The compound according to claim 1, wherein:

R¹⁰ represents a substituent represented by formula (G4-1);

R¹ to R⁹ separately represent any one of hydrogen, an alkyl group having 1 to 6 carbon atoms, a cycloalkyl group having 3 to 6 carbon atoms, and an aryl group having 6 to 13 carbon atoms.

5. The compound according to claim 1, wherein the compound is represented by formula (201),

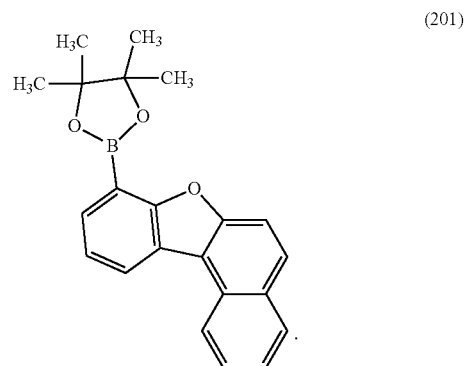

6. A compound represented by formula (G4):

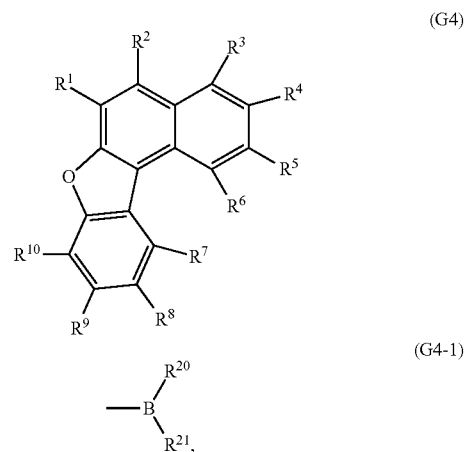

wherein:

one of R⁷ to R¹⁰ represents a substituent represented by formula (G4-1);

R¹ to R⁶ and the others of R⁷ to R¹⁰ separately represent any one of hydrogen, an alkyl group having 1 to 6 carbon atoms, a cycloalkyl group having 3 to 6 carbon atoms, and an aryl group having 6 to 13 carbon atoms; R²⁰ and R²¹ separately represent an alkoxy group having 1 to 6 carbon atoms.

7. The compound according to claim 6, wherein the aryl group having 6 to 13 carbon atoms is unsubstituted or substituted by any one of an alkyl group having 1 to 6 carbon atoms, a cycloalkyl group having 3 to 6 carbon atoms, and an aryl group having 6 to 13 carbon atoms.

8. The compound according to claim 6, wherein the alkoxy group having 1 to 6 carbon atoms is unsubstituted or substituted by any one of an alkyl group having 1 to 6 carbon atoms, a cycloalkyl group having 3 to 6 carbon atoms, and an aryl group having 6 to 13 carbon atoms.

9. The compound according to claim 6, wherein:
R¹⁰ represents a substituent represented by formula (G4-1);
R¹ to R⁹ separately represent any one of hydrogen, an alkyl group having 1 to 6 carbon atoms, a cycloalkyl group having 3 to 6 carbon atoms, and an aryl group having 6 to 13 carbon atoms.

* * * * *