

**(12) PATENT**  
**(19) AUSTRALIAN PATENT OFFICE**

**(11) Application No. AU 199917774 B2**  
**(10) Patent No. 753568**

(54) Title  
**Indicating device for use with a dispensing device**

(51)<sup>7</sup> International Patent Classification(s)  
**A61M 015/00**

(21) Application No: **199917774**

(22) Application Date: **1999.01.13**

(87) WIPO No: **WO99/36115**

(30) Priority Data

| (31) Number      | (32) Date         | (33) Country |
|------------------|-------------------|--------------|
| <b>09/008184</b> | <b>1998.01.16</b> | <b>US</b>    |
| <b>09/149708</b> | <b>1998.09.08</b> | <b>US</b>    |

(43) Publication Date : **1999.08.02**

(43) Publication Journal Date : **1999.10.07**

(44) Accepted Journal Date : **2002.10.24**

(71) Applicant(s)  
**1263152 Ontario Inc.**

(72) Inventor(s)  
**Richard Blacker; Daniel K. Engelbreth; James N. Schmidt**

(74) Agent/Attorney  
**SPRUSON and FERGUSON,GPO Box 3898,SYDNEY NSW 2001**

(56) Related Art  
**GB 2191032**  
**WO 92/09324**  
**EP 488609**

17774/99



PCT

WORLD INTELLECTUAL PROPERTY ORGANIZATION  
International Bureau

INTERNATIONAL APPLICATION PUBLISHED UNDER THE PATENT COOPERATION TREATY (PCT)

|   |  |  |   |
|---|--|--|---|
| (51) International Patent Classification <sup>6</sup> :<br><b>A61M 15/00</b>  |  | A2   | (11) International Publication Number:<br><b>WO 99/36115</b>    |
|   |  |  | (43) International Publication Date:<br>22 July 1999 (22.07.99) |
| (21) International Application Number:<br>PCT/IB99/00032  |  | (81) Designated States: AL, AM, AT, AU, AZ, BA, BB, BG, BR, BY, CA, CH, CN, CU, CZ, DE, DK, EE, ES, FI, GB, GD, GE, GH, GM, HR, HU, ID, IL, IN, IS, JP, KE, KG, KP, KR, KZ, LC, LK, LR, LS, LT, LU, LV, MD, MG, MK, MN, MW, MX, NO, NZ, PL, PT, RO, RU, SD, SE, SG, SI, SK, SL, TJ, TM, TR, TT, UA, UG, UZ, VN, YU, ZW, ARIPO patent (GH, GM, KE, LS, MW, SD, SZ, UG, ZW), Eurasian patent (AM, AZ, BY, KG, KZ, MD, RU, TJ, TM), European patent (AT, BE, CH, CY, DE, DK, ES, FI, FR, GB, GR, IE, IT, LU, MC, NL, PT, SE), OAPI patent (BF, BJ, CF, CG, CI, CM, GA, GN, GW, ML, MR, NE, SN, TD, TG). |   |
| (22) International Filing Date:<br>13 January 1999 (13.01.99)   |  |  |   |
| (30) Priority Data:<br>09/008,184            16 January 1998 (16.01.98)    US<br>09/149,708            8 September 1998 (08.09.98)    US  |  |  |   |
| (71) Applicant: 1263152 ONTARIO INC. [CA/CA]; 725 Third Street, London, Ontario N5V 5G4 (CA).   |  |  |   |
| (72) Inventors: BLACKER, Richard; 1371 Commissioners Road, London, Ontario N6K 4H8 (CA). ENGELBRETH, Daniel, K.; 45-536 Third Street, London, Ontario N5V 4R5 (CA). SCHMIDT, James, N.; 22 Foxchapel, London, Ontario N6G 122 (CA). |  | <p><b>Published</b><br/><i>Without international search report and to be republished upon receipt of that report.</i></p>  |   |

IP AUSTRALIA  
 0 2 AUG 1999  
 RECEIVED

(54) Title: INDICATING DEVICE FOR USE WITH A DISPENSING DEVICE

(57) Abstract

An indicating device for use with a dispensing device that dispenses metered dosages of a medicament from a container (100) having a valve (110) moveable between an open and closed position. In a preferred embodiment, the container (100) is reciprocally moveable within the housing (10) along a longitudinal axis. The housing (10) preferably has a well (18) adapted to receive a valve stem (110) and an exhaust port (26). The well (18) communicates with the port (26) such that the metered dosage of medicament is dispensed through the port (26) when the valve (110) is moved to the open position. An indicator assembly comprises an indicator member (50) that includes dosage indicia (66) visible to a user. In a preferred embodiment, the indicator assembly is provided in an indicator module (120). A method for dispensing measured dosages is also provided, along with a kit capable of being assembled as an inhalation device. A delivery system having a key member (300) and a key entry passageway is also provided.

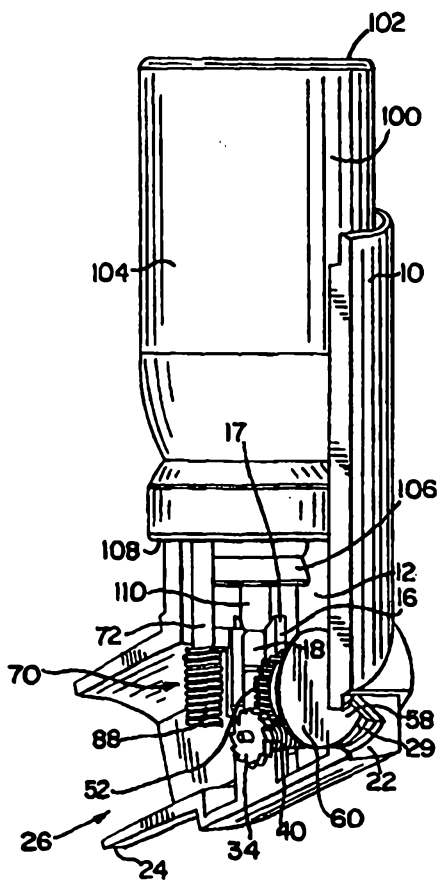

## INDICATING DEVICE FOR USE WITH A DISPENSING DEVICE

### Background of the Invention

The present invention relates generally to an indicating device, and in particular, to an indicating device for indicating the number of metered dosages of a substance, and in particular a medicament, that has been dispensed by, or remains in, a dispensing device.

Delivery systems, and in particular, dispensing devices, have been developed that include a counting or dose indicating device to indicate the number of metered doses of substance that have been dispensed from the delivery system, or to indicate the number of doses remaining therein. For example, patients have certain conditions that can be treated with medicaments dispersed in an aerosol and administered to the patient by inhalation. In one format, the aerosol and medicaments are contained in a container, and dispensed in metered, or measured, dosages with the dispensing device, which can include an actuator boot. In such an arrangement, it can be important for the patient to be able to ascertain the number of metered doses remaining in the container, either by an indication of the number remaining therein or by knowledge of the number already dispensed therefrom, such that the patient is not caught unaware with an empty container when in need of the medicament. Thus, it may be important for the dispensing device to provide an

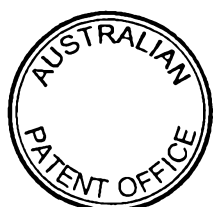

accurate indication of either the number of doses remaining in the container, or the number of doses already dispensed therefrom.

Typically, a conventional aerosol container includes a body and a valve stem which can be depressed relative to the body so as to emit the metered dose of aerosol and medicament. The container is usually  
5 supplied with a predetermined number of metered doses, e.g., on the order of about 200, such that the counting of the number of valve stem depressions, and corresponding number of dispensed metered doses, can be directly correlated with the number of doses remaining in the  
10 container.

In operation, the container is typically received within a housing of the dispensing device, wherein the valve is brought into engagement with a support block in the housing. The user administers the medicament by moving the container relative to the housing so as to depress the valve  
15 stem and internal valve and thereby release a metered dose, which is typically administered to the user through a port or mouthpiece extending from the housing. In an alternative delivery system, the metered dose can be first discharged into a chamber, and thereafter administered to the patient. After the metered dose is discharged from the container, the  
20 valve stem, which is typically spring loaded, biases the container away from the support block so as to again move the container relative to the housing. In this way, a metered dose of medicament is discharged by each cycle of linear reciprocal movement of the container relative to the housing.

Some dispensing devices have indicating devices that convert the linear reciprocal movement of the container relative to the housing into a one-way, or single-cycle, movement of an indicator, wherein the indicator identifies the relative fullness of the container, the number of metered  
25 doses remaining therein or the number of doses already administered.

30 Although these dispensing devices with indicators have provided the

advantage of generally being able to keep track of the number of dosages, there remains room for improvement. For example, indicating devices of this nature may include complex moving parts which can be difficult to assemble and expensive to manufacture. Such devices may also be susceptible to counting inaccuracies due to the configuration of the indexing or mating parts, or require excessive amounts of space within the housing to accommodate the relatively large or numerous moving parts. Others still may impede or interfere with the airflow and medicament being dispensed from the inhalation device. Alternatively, some devices use electrical circuitry to count or record the disbursements. Such devices can be relatively expensive to manufacture, however, and typically require a power source which may be susceptible to damage in various environments, such as moist conditions.

### Object of the Invention

It is an object of the present invention to overcome or substantially ameliorate some of the disadvantages of the prior art, or at least to provide a useful alternative.

### Summary of the Invention

There is firstly disclosed herein an aerosol dispenser for dispensing metered dosages of medicaments from a container having a valve stem extending longitudinally therefrom and moveable between a closed position and an open position, said container dispensing said metered dosage when said valve stem is moved to the open position, said aerosol dispenser comprising:

a housing adapted to support said container reciprocally moveable within said housing along a longitudinal axis, said housing having a well adapted to receive said valve stem and an exhaust port, said well communicating with said exhaust port such that said metered dosage of medicament is dispensed through said exhaust port when said valve stem is moved to the open position;

a ratchet wheel rotatably mounted in said housing and adapted to be responsive to the reciprocal movement of said container in said housing along said longitudinal axis such that said longitudinal movement of said container causes said ratchet wheel to rotate;

a worm rotatably mounted in said housing along a first rotation axis substantially perpendicular to the longitudinal axis of the movement of the container within the housing, said worm connected to said ratchet wheel such that rotation of said ratchet wheel causes said worm gear to rotate about said first rotation axis; and



an indicator member comprising a circular gear engaging said worm, said circular gear mounted in said housing about a second axis of rotation substantially perpendicular to the longitudinal axis of the movement of the container within said housing and to the first rotation axis of the worm, said indicator member comprising  
 5 dosage indicia visible to the user.

There is further disclosed herein an aerosol dispenser for dispensing metered dosages of medicaments from a container having a valve stem extending longitudinally therefrom and moveable between a closed position and an open position, said container dispensing said metered dosage when said valve stem is moved to the open position, said  
 10 aerosol dispenser comprising:

a housing adapted to support said container reciprocally moveable within said housing along a longitudinal axis, said housing having a well adapted to receive said valve stem and an exhaust port, said well communicating with said exhaust port such that said metered dosage of medicament is dispensed through said exhaust port when said  
 15 valve stem is moved to the open position;

a worm rotatably mounted in said housing about a first rotation axis transverse to said longitudinal axis, said worm adapted to be responsive to the reciprocal movement of said container in said housing along said longitudinal axis such that said longitudinal movement of said container causes said worm to rotate about said first rotation axis; and  
 20

an indicator member comprising a circular gear engaging said worm, said circular gear mounted in said housing about a second axis of rotation transverse to the longitudinal axis of the movement of the container within said housing and to the first rotation axis of said worm, said indicator member comprising dosage indicia visible to the user.  
 25

There is further disclosed herein an inhalation device for dispensing metered dosages of medicaments from a container comprising:

a housing having a longitudinally extending cavity and a well located at a bottom of said cavity, said housing comprising a mouthpiece having an exhaust port communicating with said well;  
 30

said container comprising a valve stem extending longitudinally therefrom and moveable between a closed position and an open position, said container containing a plurality of metered dosages of medicaments, said valve stem dispensing one of said plurality of said metered dosages when said valve stem is moved to the open position, said container disposed in said cavity of said housing such that said valve stem is received



within said well, said container reciprocally moveable within said housing along said longitudinal extent of the cavity such that said valve stem is moved between said open and closed position by engagement with said well;

a ratchet wheel rotatably mounted in said housing;

5 an actuator member moveably mounted within said housing and comprising an arm having an end portion selectively engaging said ratchet wheel in response to the reciprocal movement of said container in said housing along said longitudinal axis such that said longitudinal movement of said container and said actuator arm causes said ratchet wheel to rotate about a first rotation axis;

10 a worm rotatably mounted in said housing along said first rotation axis transverse to the longitudinal axis of the movement of the container within the housing, said worm coaxially mounted to said ratchet wheel such that rotation of said ratchet wheel in response to the selective engagement of said arm of said actuator member causes said worm gear to rotate about said first rotation axis; and

15 an indicator member comprising a circular gear engaging said worm and a indicator wheel coaxially mounted to said circular gear, said circular gear and said indicator wheel mounted to said housing on an axle defining a second axis of rotation transverse to the longitudinal axis of the movement of the container within the housing and to the first rotation axis of the worm, said indicator wheel having a planar face comprising dosage indicia visible to the user.

20

There is further disclosed herein an indicator module adapted to be received within a aerosol dispenser housing for indicating the number of metered dosages of medicaments dispensed from a container disposed within said dispenser housing and having a valve stem extending longitudinally therefrom and moveable between a closed position and an open position along a longitudinal axis, said container dispensing said metered dosage when said valve stem is moved to the open position, said dispenser housing comprising a wall and a support block supporting said valve stem spaced apart from said wall, said indicator module comprising:

25

a key member adapted to be mounted to said container;

30 a module housing adapted to be received within said dispenser housing between said support block and said wall of said housing, wherein said module housing has a passageway shaped to receive at least a portion of said key member as said container is disposed in said dispenser housing; and

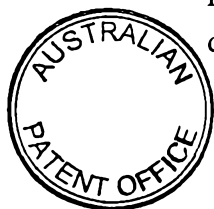

an indicator member mounted in said module housing, said indicator member comprising dosage indicia.

There is further disclosed herein an aerosol dispenser for dispensing metered dosages of medicaments from a container having a valve stem extending longitudinally therefrom and moveable between a closed position and an open position, said container  
5 dispensing said metered dosage when said valve stem is moved to the open position, said aerosol dispenser comprising:

a housing adapted to support said container reciprocally moveable within said housing along a longitudinal axis, said housing having a well adapted to receive said  
10 valve stem and an exhaust port, said well communicating with said exhaust port such that said metered dosage of medicament is dispensed through said exhaust port when said valve stem is moved to the open position;

a worm rotatably mounted in said housing about a first rotation axis transverse to said longitudinal axis, said worm adapted to be responsive to the reciprocal movement of  
15 said container in said housing along said longitudinal axis such that said longitudinal movement of said container causes said worm to rotate about said first rotation axis; and

an indicator member comprising a circular gear engaging said worm, said circular gear mounted in said housing on an axle forming a second axis of rotation transverse to the first rotation axis of the worm and non-parallel to the longitudinal axis of  
20 the movement of the container within the housing, said indicator member comprising dosage indicia visible to the user.

There is further disclosed herein a method for dispensing metered dosages of medicaments from a container having a valve stem extending longitudinally therefrom and moveable between a closed position and an open position, said container dispensing  
25 said metered dosage when said valve stem is moved to the open position, said method comprising the steps of:

providing a housing having a well and an exhaust port, said well communicating with said exhaust port;

providing said container filled with a predetermined number of said metered  
30 dosages, said container moveably supported in said housing along a longitudinal axis, said container comprising a valve stem received within said well of said housing and moveable between a closed and open position as said container is moved longitudinally within said housing, said container adapted to discharge one of said metered dosages when said valve stem is moved to the open position;





moving said container along said longitudinal axis so as to move said valve stem to the open position and thereby discharge one of said metered dosages through said well and said port;

rotating a worm mounted in said housing a predetermined angular amount in response to said longitudinal movement of said container, said worm mounted along an axis transverse to said longitudinal axis of said movement of said container within said housing;

providing an indicator member mounted in said housing about an axis transverse to the longitudinal axis and to said axis of said worm, said indicator member comprising a circular gear;

engaging said circular gear with said worm so as to rotate said circular gear about said axis transverse to said longitudinal axis and to said axis of said worm; and

providing indicia on said indicator member to indicate the number of metered dosages remaining in or dispensed from said container.

There is further disclosed herein an apparatus for dispensing metered dosages of medicaments from a container, said apparatus comprising:

a dispenser housing comprising a support block and a wall spaced apart from said support block, said support block having a well and an orifice communicating with said well, said dispenser housing having a cavity formed above said support block;

said container comprising a valve stem, wherein said container is disposed in said cavity and said valve stem is mounted in said well of said support block;

a dose indicator module for indicating the number of metered doses remaining in or dispensed from said container, said dose indicator module comprising a module housing mounted in said dispenser housing below said container in the space between said support block and said dispenser housing wall, wherein said module housing has a passageway formed therein; and

a key member mounted to said container, said key member shaped to be received in said passageway as said valve stem of said container is mounted in said support block.

In a preferred embodiment of the indicating device, the housing comprises at least one engagement member and the indicator assembly includes a plurality of indicator members, including at least a first and second indicator member. The plurality of indicator members are coaxially mounted in the housing. At least one of the first and second indicator members includes an advancement member, while at least the other of the first and second indicator members includes a plurality of teeth. In operation, the first



indicator member is rotated relative to the second indicator member such that the engagement member selectively engages and biases the advancement member into operable engagement with at least one of the plurality of teeth so as to rotate the second indicator member an incremental amount.

5 In a preferred embodiment, an actuator member is mounted in the housing and is responsive to the movement of the container. The actuator member selectively engages at least one of the plurality of teeth on the first indicator member so as to advance the first indicator member an incremental amount in response to the movement of the container relative to said housing. A spring is preferably disposed in the housing to bias the  
10 actuator member into engagement with the container.

Alternatively, in another preferred embodiment, the first indicator member is rotated a predetermined amount in response to the movement of the valve between a closed and open position, or vice versa. Upon a predetermined number of movements of the valve, the first indicator member causes the second indicator member to rotate a  
15 predetermined amount.

The present invention preferably provides significant advantages over other indicating devices. In particular, the worm provides for a compact drive component that does not occupy excess space within the housing. Moreover, the worm provides for high gear reduction ratios while maintaining a continuous engagement with the circular worm  
20 gear. The continuous engagement of the worm and circular gear ensures that the accuracy of the counting device is maintained, while simultaneously simplifying the manufacturing and assembly process.

The use of a circular gear having an axis non-parallel, and preferably transverse or perpendicular to the longitudinal movement of the container within the housing, also  
25 provides several advantages. Importantly, the gear can be easily mounted to the housing with an inexpensive and easy-to-install axle. Thus, the circular gear provides for a compact single-cycle device that fits easily into the housing, and which maintains continuous engagement with the worm gear for improved and accurate indexing of the indicator member. Moreover, the components are arranged so as to not interfere with or  
30 otherwise impede the air flow from the valve stem to the exhaust port of the housing. In addition, the indicator wheel, which is preferably coaxially mounted with the worm gear, provides an ideal planar surface for displaying the dosage indicia. The indicia can be easily viewed by the user through the viewing window.



The plurality of indicator members can be mounted in a compact arrangement to provide accuracy and reliability under various operating conditions but which does not impede or obstruct the airflow to the user. Moreover, the various parts are relatively inexpensive to manufacture and assemble. The indicia, which are visible to the user through the viewing window, are easy to read and readily accessible to the user.

The indicia module, with any of the various embodiments of indicating assemblies disposed therein, also prevents several advantages. In particular, the self-contained unit can be separately manufactured and installed as needed in any number of conventional types of dispensing devices with minimal modification thereof. Moreover, the module can be easily installed without interfering with or otherwise impeding the air flow from the valve stem to the exhaust port and ultimately to the user.

The key member also prevents several advantages. In particular, differently configured key members and passageways can be installed between containers holding different substances such as medicaments and corresponding delivery system housings so as to prevent the user from interchanging various containers and housings so as to thereby alter the number of doses being counted. The key member and passageway can also prevent a user from using the wrong delivery system for a particular container having a particular substance, such as a medicament.

#### Brief Description of the Drawings

A preferred embodiment of the invention will now be described, by way of example only, with reference to the accompanying drawings.

FIGURE 1 is a perspective view of a dispensing device with a viewing window revealing dosage indicia.

FIGURE 2 is a perspective view of one embodiment of the dispensing device with a portion of the housing cut away.

FIGURE 3 is a perspective view of one embodiment of the indicator assembly.

FIGURE 4 is a perspective view of an alternative embodiment of the dispensing device.

FIGURE 5 is a perspective view of the dispensing device shown in FIGURE 4 with a portion of the housing cut away.

FIGURE 6 is a perspective view of a container, a dispenser housing and one embodiment of an indicator module with a portion of the housing cut away.



8b

FIGURE 7 is an exploded perspective view of a container, a dispenser housing and one embodiment of the indicator module with a portion of the housing cut away.

FIGURE 8 is an exploded perspective view of one embodiment of the indicator module.

FIGURE 7

FIGURE 8

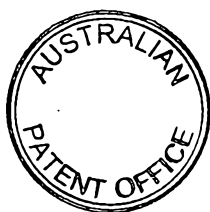

FIGURE 9 is an exploded perspective view of the indicator module from the opposite side as shown in Figure 8.

FIGURE 10 is an exploded perspective view of a container, and an alternative embodiment of the dispenser housing and the indicator  
5 module.

FIGURE 11 is a perspective view of the alternative embodiment of the indicator module shown in Figure 10.

FIGURE 12 is a section cut of a housing and an indicator module mounted therein.

10 FIGURE 13 is a top view of one embodiment of the indicator module.

FIGURE 14 is a rear view of the indicator module shown in Figure 13.

15 FIGURE 15 is a cross-sectional view of the indicator module taken along line 15-15 of Figure 13.

FIGURE 16 is a cross-sectional view of the indicator module taken along line 16-16 of Figure 13.

FIGURE 17 is a cross-sectional view of the indicator module taken along line 17-17 of Figure 13.

20 FIGURE 18 is a cross-sectional view of the indicator module taken along line 18-18 of Figure 13.

FIGURE 19 is a perspective view of an alternative embodiment of the module.

25 FIGURE 20 is a cross-sectional view of the indicator module taken along line 20-20 of Figure 14.

FIGURE 21 is an exploded view of a container, a key member and an indicator module.

FIGURE 22 is a top view of the key member.

30 FIGURE 23 is a cross-sectional view of the key member taken along line 23-23 of Figure 22.

FIGURE 24 is a perspective view of a container and an alternative embodiment of the indicator module mounted in a dispenser housing with a portion of the housing cut away.

5 FIGURE 25 is an exploded perspective view of an alternative embodiment of an indicator module, key member and indicator assembly.

FIGURE 26 is a top perspective view of a first member of one embodiment of the indicator module housing.

FIGURE 27 is a bottom perspective view of the member shown in Figure 26.

10 FIGURE 28 is a perspective view of one embodiment of an indicator member.

FIGURE 29 is an opposite perspective view of the indicator member shown in Figure 28.

15 FIGURE 30 is a top perspective view of a second member of one embodiment of the indicator module with an axle installed therein.

FIGURE 31 is a perspective view of an actuator member.

FIGURE 32 is a perspective view of a container with an alternative embodiment of a key member installed thereon positioned above one embodiment of an indicator module.

20 FIGURE 33 is a perspective view of an alternative embodiment of the key member.

FIGURE 34 is an exploded perspective view of an alternative embodiment of a key member being applied to a container.

25 FIGURE 35 is a cross-sectional view of an indicator module showing an advancement member of a first indicator member, an engagement member and a second indicator member.

FIGURE 36 is a cross-sectional view of the advancement member of the first indicator member as it is first engaged by the engagement member in the indicator module housing.

FIGURE 37 is a cross-sectional view of the advancement member as it is biased by the engagement member into engagement with the second indicator member so as to rotate the second indicator member.

5 FIGURE 38 is a cross-sectional view of the advancement member as it is released by the engagement member and disengages from the second indicator member.

FIGURE 39 is an exploded perspective view of an alternative embodiment of an indicator module and indicator assembly.

10 FIGURE 40 is an enlarged side view of an actuator member in a disengaged position adjacent a first indicator member.

FIGURE 41 is a side view of the actuator member engaging the first indicator member with the non-return being biased outwardly.

FIGURE 42 is a perspective side view of an alternative embodiment of an indicator member.

15 FIGURE 43 is an opposite perspective side view of the indicator member of Figure 42.

FIGURE 44 is a cross-sectional view of an advancement member on a first indicator member, a second indicator member and an engagement member.

20 FIGURE 45 is a cross-sectional view of the advancement member as it is first engaged by the engagement member.

FIGURE 46 is a cross-sectional view of the advancement member as it is biased by the engagement member into engagement with the indicator member.

25 FIGURE 47 is a cross-sectional view of the advancement member as it is further biased by the engagement member into engagement with the second indicator member.

30 FIGURE 48 is a perspective view of an alternative embodiment of an indicator assembly disposed on a lower member of the module housing.

## DETAILED DESCRIPTION OF THE PRESENTLY PREFERRED EMBODIMENTS

Referring to the drawings, and in particular FIGS. 1, 4, 6, 7 and 24,  
a delivery system, configured as a dispensing device, or dispenser, is  
5 shown as including a housing **10**, or actuator boot, and a container **100**  
disposed therein. The housing **10** has a longitudinally extending cavity  
**12** shaped to receive the container. A top portion of the housing is  
generally open such that the container can be inserted in the housing  
through opening **14** and be installed therein with a bottom end **102** of the  
10 container protruding from the housing and exposed to the user for  
actuation.

It should be understood that the term "delivery system," as used  
herein, is meant to include a system or apparatus for delivering a  
substance from a container, reservoir, or similar repository, to a user, and  
15 includes but is not limited to the disclosed dispensing device, which  
delivers the substance to the user in the form of an aerosol that is inhaled  
by the user. The term "dispensing device," as used herein, is meant to  
include devices that extrude, spray or otherwise feed out or deliver a  
substance in convenient units, and includes, but is not limited to, the  
20 disclosed inhalation device which delivers metered dosages of a  
substance in aerosol form for inhalation by the user.

The term "longitudinal" as used herein is intended to indicate the  
direction of the reciprocal movement of the container relative to the  
housing. The terms "top," "bottom," "upwardly" and "downwardly" are  
25 intended to indicate directions when viewing the inhalation devices as  
shown in the Figures, but with the understanding that the container is  
inverted such that the top surface thereof is located adjacent the bottom  
of the housing and vice versa.

As shown in FIGS. 5, 6 and 7, a cylindrical support block **16**  
30 having a well **18** is formed in a bottom portion **22** of the housing. An



orifice **20** penetrates the support block to communicate with a bottom portion of the well. A mouthpiece **24**, intended for insertion into the mouth of a patient, forms an exhaust port **26** that communicates with the orifice and well. The mouthpiece **24** extends laterally from the housing so as to facilitate insertion of the mouthpiece into the mouth of the patient.

The container **100** is formed as a cylindrical canister **104** having a **106** hub disposed on a top surface **108** thereof. A valve stem **110** extends longitudinally from the hub. The valve stem extends coaxially from the canister and is biased outwardly therefrom by a spring (not shown) mounted within the canister. The container **100** is mounted in the housing by press fitting the valve stem **110** in the well **18** of the support block. It should be understood that the container can be configured in a variety of shapes and sizes, and that the substance contained therein can be released by any number of valve systems that are well known in the art. It should also be understood that the valve system can be actuated by a variety of actuators, including, but not limited to, various pumps, levers, actuator boots, buttons and the like. In such embodiments, the valve system can be actuated by an actuator moveable relative to the container and housing such that the container remains stationary relative to the housing.

In a preferred embodiment, the container **100** is filled with a substance which is dispensed therefrom in specific metered doses by depressing or moving the valve stem **110** from an extended closed position to a depressed open position, which in turn opens the valve or valve system. Preferably the substance is a medicament, although it should be understood that the container could be used to hold a variety of non-medicinal substances, including, but not limited to, various liquids, foams or aerosols that can be delivered by various delivery systems, and/or dispensing devices. A medicament is defined as a substance that can be used in therapy, such as for various therapeutic treatments,

including the treatment of diseases (e.g., respiratory ailments) and for the relief of pain, and should be understood to include medicines and medicinal substances in general. A single metered dose is dispensed from the container by each reciprocal, longitudinal movement of the valve stem and attendant opening and closing of the valve. The medicament is typically delivered to the user, or patient, through their mouth and/or nose in the form of an aerosol, spray or liquid.

In operation, the opening of the valve stem and valve is effected by moving the container **100** reciprocally within the housing **10** along a longitudinal axis, defined by the valve stem and the reciprocal movement of the container, by depressing the exposed bottom end **102** of the canister relative to the housing **10** so as to move the valve stem **110** to the open position as it is supported within the well by the support block. Alternatively, an actuator can be moved to open the valve system of the container, which can remain stationary with respect to a supporting housing, a cap and/or an indicating device mounted thereto. For example, the actuator can be attached to the end of the container in the form of a pump device or the like.

Referring to FIGS. 5-7, as the valve stem is moved to the open position, the container dispenses a metered dose of the substance in aerosol form through the well **18** and orifice **20** and into the exhaust port. The substance in aerosol form is then transmitted to the user through the exhaust port of the mouthpiece by way of either a self-generated or assisted airflow. Alternatively, metered doses of liquids and the like can be dispensed from the container.

In other delivery systems, which may also include a dispensing device, the housing and holder for the container are attached to a component having a chamber with an output end. Examples of these kinds of delivery systems and dispensing devices are shown for example in U.S. Patent 5,012,803, issued May 7, 1991, and U.S. Patent

4,460,412, issued September 11, 1984, the entire disclosures of which are hereby incorporated herein by reference. (No license, expressed or implied, is intended to be granted to either of these patents by reason of the incorporation by reference herein.) In these kinds of delivery systems, the component having the chamber can be adapted to receive the mouthpiece of the housing, or it can be integrally connected with a holder supporting the container. In either embodiment, the metered dose of substance, preferably a medicament, in aerosol is first dispensed from the container into the chamber, and thereafter inhaled by the user.

In a preferred embodiment, the container **100** is intended to dispense a predetermined number of metered doses of substance. For example, conventional inhaler containers typically hold on the order of 100 to 200 metered doses. In operation, it is important that the user be aware of the number of metered doses remaining in the container such that the user is not caught unaware with an empty canister when in need of the substance, such as a medicament.

Now referring to FIGS. 2 and 3, a dispensing device, configured as an aerosol dispenser, is shown as including a housing, a container mounted therein as described above and an indicator assembly. The indicator assembly includes a ratchet gear **32** coaxially mounted with a worm **40** on an axle **42** in a lower portion of the housing. A plurality of teeth **34** are formed about the periphery of the ratchet gear. The teeth **34** are cut or formed with a tapered surface **36** and engagement surface **38**. In a preferred embodiment, the ratchet and worm are formed out of a hard durable plastic. It should be understood, however, that other materials such as metal would also work. The ratchet and worm can be made as separate parts, or molded as a single integral member.

In a preferred embodiment, the axle **42** and worm **40** define an axis of rotation transverse, or perpendicular, to the longitudinal axis defined by the valve stem and reciprocal movement of the container

relative to the housing. Opposite ends of the axle **42** are rotatably supported in the housing.

Also as shown in FIGS. 2 and 3, an indicator member **50** comprises a circular worm gear **52** and indicator wheel **58** coaxially mounted on an axle. In a preferred embodiment, the axle **56** defines an axis of rotation transverse to the axis defined by the worm and also transverse to the longitudinal axis defined by the reciprocal movement of the container relative to the housing. The axle **56** is rotatably supported in the housing. Teeth **54** are formed around the periphery of the worm gear **52** and are shaped to permanently engage the worm **40**. As shown in FIG. 2, the indicator wheel **58** has a planar face **60** which is exposed to the patient through a viewing window **28** formed in the housing.

The ratchet gear **32**, worm **40**, worm gear **52** and indicator wheel **58** provide an ideal arrangement for indicating the number of doses remaining in the container, or the number dispensed therefrom. In particular, relatively high reduction ratios are made possible through use of the ratchet, worm and worm gear without the corresponding requirement of providing extremely fine teeth on one or more of the ratchet gear and worm gear. Moreover, the worm and worm gear interface avoids the associated inaccuracies introduced by the mating, and potential skipping, of conventional spur gears having fine teeth. Furthermore, the installation of the indicator member is effected by the installation of a simple axle which can be supported in a plurality of positions and angular orientations within the housing. Importantly, the high reduction ratio realized with the worm **40** allows for the worm gear **52** to have a relatively small diameter, such that it can be easily mounted within small spaces within the housing. Indeed, as shown in FIGS. 6 and 12, the entire indicator assembly can be mounted behind the support block **16** and below the upper surface **17** thereof such that the assembly does not interfere with the dispensing of the medicament from the orifice

or with the airflow generated by the patient in administering the medicament.

Referring to FIG. 5, an actuator member **70** is configured as a post member **72** moveably supported in the housing along an axis parallel to the longitudinal axis defined by the reciprocal movement of the container within the housing. In an alternative embodiment shown in FIGS. 7-9, the post member includes an upper portion **74**, a middle portion **76** and a lower portion **78**. A resilient arm member **80** extends from the middle portion of the post member and terminates in a tapered hook member **82** shaped to selectively engage one of the ratchet wheel teeth. The middle portion **76** is defined by upper and lower stop surface **84**, **86**. A spring **88** is disposed about the lower portion **78** of the post member and engages the lower stop surface **86** so as to bias the actuator member upwardly against the top surface **108** of the canister as shown in FIG. 7. Although a compression spring is shown in the Figures, it should be understood that cantilever, torsion, leaf and tension springs, and the like, would also work to bias the actuator member upwardly into engagement with the container. The springs can be made of metal or plastic.

In an alternative embodiment, shown in FIGS. 2 and 3, actuator member **90** includes locking ring **92** and a resilient arm member **94** extending longitudinally downwardly therefrom. A longitudinal slit **96** is formed in the locking ring so as to allow for the locking ring **92** to be expanded and disposed around the hub **106** (shown in FIG. 5) of the canister in a snap fit configuration such that the valve stem of the container extends through opening **98** of the locking ring. A distal end of the resilient arm member terminates in a hook member **95** which is shaped to selectively engage the teeth of the ratchet wheel.

In the operation of the embodiment shown in FIGS. 6-9, 13-18 and 20, the container is moved longitudinally within the housing so as to depress the valve stem to the open position so as to open the valve as

explained above. As the container is moved downwardly within the housing, the actuator member **70** is moved longitudinally downward such that the hook member **82** engages the ratchet wheel and rotates it a predetermined angular amount corresponding to the pitch of the teeth.

5 When the container is released by the user, the spring (not shown) within the container biases the container upwardly within the housing along the longitudinal axis such that the valve stem **110** is moved to the closed position within the container so as to close the valve. As the container moves upwardly, the resilient arm member **80** is biased laterally outward  
10 as a tapered end portion of the hook member **82** slides against the tapered surface **36** of one of the ratchet teeth. As the container and resilient arm member reach the top of the stroke, wherein the valve stem is moved completely to the closed position, the resilient arm member **80** returns to its normal straightened configuration as the hook member **82**  
15 slips past the tapered surface of one of the teeth so as to be positioned over the engagement surface **38** of that tooth **34** for the next cycle.

Alternatively, the operation of the ratchet wheel can be reversed as shown in FIG. 3. In this embodiment, the resilient arm member **94** is biased outwardly by the tapered surface of one of the ratchet gear teeth  
20 on the downstroke. At the bottom of the stroke, the hook member **95** slips into an underlying relationship with the engagement surface of the tooth. When the container is released by the user, the spring (not shown) within the canister biases the container upwardly within the housing along the longitudinal axis such that the valve stem is moved to  
25 the closed position within the container. As the container moves upwardly with respect to the housing, the resilient arm member **94** moves longitudinally upward such that the hook member **95** engages the engagement surface **38** of one of the teeth and thereby rotates the ratchet wheel an incremental amount.

In the embodiment shown in FIGS. 6-9, 13-18 and 20, it is the force of the spring **88** that moves the arm member **80** upwardly so as to return the actuator member in preparation for another cycle. In the alternative embodiment shown in FIGS. 2 and 3, it is the movement of the container, as it is biased upwardly by the internal spring acting on the valve stem, that causes the locking ring **92** and arm member **94** to move upwardly and thereby rotate the ratchet gear.

Referring to FIGS. 8 and 17, a resilient non-return member **200** engages the ratchet gear adjacent the hook member so as to ensure that the rotation of the ratchet gear is unidirectional. Alternatively, the non-return member can be positioned to engage the ratchet gear opposite the actuator arm member. The non-return member includes an end portion adapted to engage the engagement surface of the ratchet gear teeth. As the ratchet gear is rotated by the actuator, the non-return member slides along the tapered surface of one of the teeth of the ratchet wheel and does not interfere with the rotation thereof.

The rotation of the ratchet gear causes the worm **40** to rotate a desired predetermined amount. It should be understood that the desired amount of rotation is dependent upon the diameter of the ratchet wheel and the number of teeth positioned thereabout. Rotation of the worm, which permanently engages the teeth of the worm gear, causes the worm gear and indicator wheel to rotate a predetermined incremental amount. The amount of rotation of the indicator wheel is dependent upon the pitch of the worm, the number of worm threads and the pitch of the worm gear and the number of worm gear teeth. In a preferred embodiment, the worm has a single thread.

For ease of manufacturing, it is desirable to provide as coarse a pitch on each of the ratchet and worm gears as possible, although the gears are still defined as fine-toothed gears. However, it is also intended that the indicator member make only a single revolution (single-cycle)

corresponding to a complete evacuation of medicament from the container. Thus, when a large number of doses (on the order of 200 or more) are contained within the canister, it is important for the ratchet, worm and worm gear to provide a relatively high reduction ratio, such that  
5 200 linear reciprocal movements of the actuator member correspond to one or less revolutions of the indicator member. Because the ratchet gear and worm rotate together, it should be understood that the number of teeth on the ratchet gear and worm gear, and the number of threads of the worm, determine the ultimate reduction ratio between the rotation of  
10 the ratchet gear and the rotation of the indicator wheel.

For example, when the container holds 240 metered doses, an acceptable ratio is realized if the ratchet is made relatively coarse with 10 teeth and the worm gear is provided with 28 teeth. In operation, the dispensing of 10 metered doses will cause the worm to make one  
15 complete revolution so as to thereby move the worm gear one tooth. After 240 linear reciprocal movements, the worm gear has been advanced by 24 teeth. Extra teeth are provided so that the starting and ending indicia, indicating a relative fullness or emptiness of the container respectively, are not labeled one on top of the other.

In a preferred embodiment, shown in FIGS. 9 and 15, the worm gear **52** has teeth formed around only a portion of its periphery so that a gap is formed between the teeth around the remaining portion of the periphery. In operation, the gears are configured so that the worm **40** disengages from the last tooth of the worm gear as the final prescribed  
25 dose of medicament is dispensed. In this position, the indicia on the indicator wheel **58** will indicate to the user that the canister is empty. Therefore, although the user can continue to move the container so as to open the valve, the resultant movement of the actuator **70**, ratchet gear **32** and worm will not in turn rotate the indicator member as the gap in the  
30 teeth on the worm gear results in the disengagement of the worm and



worm gear. In this way, the indicator wheel is prevented from being inadvertently rotated from a full to empty reading and then back again to a full reading, which could confuse the user about the number of doses remaining in the canister.

5           The indicator wheel **58**, indicia **66** and viewing window **28** can be arranged in a variety of configurations for viewing by the user. For example, the viewing window **28**, **124** can be configured as a rectangular shaped window as shown in FIG. 2 or 10 respectively, as an arcuate shaped window **29** as shown in FIG. 4, wherein approximately 1/3 of the  
10       face of the indicator wheel is visible at any time, as a circular shaped window (not shown) or as any other shape allowing the user to view the indicator wheel and the indicia located thereon. In one embodiment, the indicia take the form of a color code, where, for example, a portion of the wheel is colored green to indicate the starting full position, a portion is  
15       colored yellow to indicate a medium fullness and a portion is colored red to indicate that the container is empty. Obviously, other colors, shading or alpha-numerical indicia can be provided on the indicator wheel to indicate the relative fullness or emptiness of the container.

          In an alternative embodiment, the indicator wheel can be oriented  
20       within the housing such that either its planar face or its circumferential surface, with indicia applied thereto, are visible to the user through the exhaust port of the mouthpiece.

          Referring to FIG. 25, an alternative embodiment of an indicator assembly is shown. The indicator assembly includes three indicator  
25       members **550** coaxially mounted on an axle **556** and rotatable thereabout. As best shown in FIGS. 28 and 29, each of the indicator members includes an indicator wheel **558** having a circumferential skirt **559** with an outer circumferential surface **560** on which indicia (shown as numbers) are applied, and a ratchet gear **552** coaxially mounted with the  
30       indicator wheel. The indicator wheel and ratchet gear have an opening

**553** shaped to receive the axle. The ratchet gear **552** includes a plurality of teeth **554** formed around its periphery. The ratchet gear is preferably integrally molded with the indicator wheel, although it should be understood that the gear and wheel can be made separately and thereafter attached one to the other by welding, adhesive and the like.

In one embodiment of the indicator member, a resilient advancement member **600** is formed from a portion of the circumferential skirt **559** by providing an elongated cutout **602** in the indicator wheel radially inward from and beneath the skirt. The advancement member **600** includes a laterally extending tooth portion **604** having an engagement surface **606**. The three indicator members are coaxially mounted such that the tooth portion **604** of the advancement member of a first indicator member overlies the ratchet gear teeth **554** of the second indicator member, and such that the tooth portion **604** of the advancement member of the second indicator member overlies the ratchet gear teeth **554** of the third indicator member. When only three indicator members are used (as shown in FIG. 25), the third indicator member does not require an advancement member, although for the sake of simplicity in manufacturing, a modular indicator member with the same indicia applied thereto and the same advancement member formed thereon is preferably used for each of the first, second and third indicator members. It should be understood by one of skill in the art that one or more indicator members may be used to provide an indication of dosages used or available, and that the three indicator members shown in the Figures is meant to be illustrative, rather than limiting. In addition, it should be understood that a plurality of indicator members refers to any number of indicator members greater than one.

In an alternative embodiment of the indicator member **650**, shown in FIGS. 39, 42 and 43, an advancement member **800** is disposed radially inward from a circumferential skirt **659** and includes a first end **657**

connected to a planar side portion or hub **655** of the indicator wheel. The advancement member includes a curved resilient portion **708** having a free end with a tooth portion **704** extending laterally outward therefrom so as to extend laterally from beneath the skirt **659** of the indicator wheel such that it overlies the teeth of the ratchet gear of an adjacent indicator member coaxially mounted therewith as shown in FIG. 48. Indicia, preferably in the form of numbers, are applied to the circumferential surface **660** of the skirt. A ratchet gear **652**, having a plurality of teeth **654** is coaxially mounted with the indicator wheel. As shown in FIG. 48, three indicator members are coaxially mounted on axle **656**.

Referring to FIGS. 25 and 39, an actuator member **570, 670**, otherwise referred to as a ratchet member, is shown as having an upper portion **574, 674** extending upwardly from a lower portion **578, 678** and a resilient arm member **580, 680** extending outwardly therefrom and terminating in a resilient hook member **582, 682** shaped to selectively engage at least one of the teeth of the ratchet gear of the first indicator member. A spring **588, 688** is disposed around the lower portion of the actuator member and biases the upper portion **574, 674** of the actuator member into engagement with the container.

Referring to FIG. 27, a housing **820** is shown as having a pair of engagement members **770** formed integrally with the housing and including ramped surfaces **772**. A plurality of non-return members **900** extend from the housing and selectively engage the ratchet gear to ensure unidirectional rotation of the indicator member as shown in FIGS. 35-38. Although the engagement members and non-return members are shown as being formed in or extending from a module housing, as described below, one of skill in the art should understand that those members or equivalent features could also be formed in or connected to the dispenser housing or actuator boot that supports the container, or disposed on or connected to the container itself.

Referring to FIGS. 25 and 35-38, the operation of the indicator assembly shown in FIG. 25 is generally shown. In particular, the container is moved longitudinally within the housing **10** so as to depress the valve stem **110** to the open position so as to open the valve as explained above. As the container is moved downwardly within the housing, or downwardly with respect to the module housing described below, the actuator member **570** is moved longitudinally downward such that the hook member **582** is biased outwardly by the ratchet gear **552** on a first outer indicator member. At the bottom of the stroke, the hook member **582** slips into an underlying relationship with the teeth on the ratchet gear. When the container is released by the user, the spring (not shown) within the container biases the container upwardly within the housing along the longitudinal axis such that the valve stem **110** and valve are moved to the closed position within the container. As the container moves upwardly, the resilient arm member **580** moves longitudinally upward such that the hook member **582** rotates the first indicator member a predetermined angular or incremented amount corresponding to the pitch of the teeth disposed around the periphery of the ratchet gear. As the container and resilient arm member reach the top of the stroke, wherein the valve stem and valve are moved completely to the closed position, the resilient arm member **580** is positioned over the ratchet gear for the next cycle. Alternatively, the operation of the actuator member and ratchet gear can be reversed as explained above with respect to the embodiment shown in FIGS. 6-9.

Referring to FIGS. 39-41 and 44-48, a plurality of resilient arm members **700** are shown as extending from a module housing so as to be aligned with the ratchet gears on each of the indicator members. The arm members **700** each serve as a combined engagement member and non-return member. In particular, as shown in FIGS. 40 and 41, the arm member **700** functions as a non-return member and includes an end

portion that is biased away from the teeth on the ratchet gear as the actuator member, or adjacent indicator member with its advancement member, is actuated to advance the ratchet gear. The operation of the actuator member **670** and ratchet gear is similar to the operation of the ratchet gear shown in FIGS. 6-9 as explained above. The arm member **700** snaps back so that the end portion engages one of the teeth of the ratchet gear so as to ensure that the rotation of the ratchet gear is unidirectional. As shown in FIGS. 44-47, the arm member **700** overlying the ratchet gears of the second and third indicator members also serves as an engagement member that selectively engages the advancement members connected to the indicator members.

In operation, the reciprocal movement of the container relative to the housing is repeated until the first indicator member **550, 650**, and its ratchet gear, are rotated one complete revolution. The predetermined number of reciprocal movements required to advance the first indicator member one revolution is equal to the number of teeth disposed about the periphery of the ratchet gear **552, 652**. As the first indicator member is rotated by successive movements of the container relative to the housing, the advancement member **600, 800** of the first indicator member is brought into selective engagement with the engagement member, configured as the ramped surface **772** formed in the housing or as the upwardly extending arm member **700**. In particular, the engagement member **700, 772** biases the tooth portion **604, 704** of the advancement member into engagement with one of the teeth **554, 654** of the ratchet gear on the second indicator member.

As the first indicator member is further rotated by successive movements of the container relative to the housing, whether it be the dispenser housing for the container or the module housing described below, the advancement member **600** engages one of the teeth on the ratchet wheel of the adjacent indicator member and advances the

indicator member a predetermined incremental angular amount corresponding to the pitch of the ratchet gear teeth. The term incremental is meant to refer to the angular amount the indicator member is moved by the advancement of one actuation, which corresponds to the movement of one tooth, regardless of whether the indicating device is indicating the number of doses left (e.g., counting down) or indicating the number of doses administered (e.g., counting up).

As the resilient advancement member **600, 800** clears the engagement member **772, 700**, it springs away from the ratchet gear such that further advancements of the first indicator member do not effect a rotation of the second indicator member until the first indicator member completes yet another cycle so as to again bring the advancement member into engagement with the next tooth of the second indicator member ratchet gear, and so on. The second indicator member **550, 650** with its advancement member **600, 800**, similarly interacts with a second engagement member overlying the teeth of the third indicator member so as to selectively engage and advance the third indicator member a predetermined incremental amount for each complete rotation of the second indicator member. It should be understood that more indicator members could be similarly assembled to provide an incremental indicating device.

In a preferred embodiment of the dispensing device, shown in FIGS. 6-10, 13-18, 20, 24, 25 and 39, the indicator assembly is arranged in an indicator module **120, 1020, 1120**. The indicator module **120, 1020, 1120** is shaped to be received within the housing where it is disposed around a portion of the support block **16**. In particular, the support block is spaced apart from the wall of the dispenser housing, otherwise referred to as the actuator boot, so as to form a donut-shaped socket in the bottom of the housing. The module includes a module housing **130, 1030, 1130** having an inner concave surface **132, 1032, 1132** that is

shaped to mate with an outer convex surface of the cylindrical support block and an outer convex **134, 1034, 1134** surface that is shaped to mate with the inner concave surface of the housing which is also generally cylindrical. In this way, the module housing is shaped to be received within the socket formed around the support block. Preferably, the module housing has a semicircular shape and fits around a portion of the support block opposite the orifice opening so as to not interfere with the dispensing of the medicament, or the airflow transmitting the medicament to the patient. In this way, the module is maintained rearwardly of the midpoint of the support block. One of skill in the art should understand, however, that the module, or module housing, can be configured in any number of different sizes and shapes so as to be accommodated in a variety of housings or cap assemblies, with or without support blocks and the like.

As shown in FIGS. 8-9, one embodiment of the module preferably includes a face portion **210** that extends from the rear convex surface of the module and includes a module viewing window **64**. The face portion snaps into the housing viewing window opening (circular opening not shown) so as to secure the module thereto. As shown in an alternative embodiment in FIGS. 10-12, the face portion includes a vertically oriented rectangular viewing window **68** and a downwardly extending locking member **122** which extends through the dispenser viewing window opening **124** and engages a bottom wall of the housing. In yet other embodiments, shown for example in FIGS. **24** and **30**, the face portion **1031, 1131** and viewing window **1064, 1164** have an elongated horizontal orientation so as to provide the user with a view of the plurality of indicator members mounted within the module. It should be understood, however, that the module can be secured within the housing by any number of conventional means, including the use of fasteners or

adhesive. Alternatively, the module can simply be press fit into the socket formed between the support block and housing wall.

In the embodiment shown in FIG. 8, the circular viewing window 64 is provided in the module housing so as to expose a substantial portion of the planar indicator wheel. Numerical indicia, corresponding to the number of doses in the container, are provided on the face 60 of the indicator wheel. An arrow, or like indicator, is applied to the housing adjacent the viewing window and provides an indication of the number of doses remaining in the housing, or the number dispensed therefrom, as the indicator wheel is rotated.

In other alternative embodiments, shown for example in FIGS. 10, 11, 25 and 39, the indicia are applied to a circumferential surface 62, 560, 660 of the indicator wheel. The module viewing window 68, 1064, 1164, which is preferably rectangular, and indicator wheel are arranged such that the circumference, or periphery, of the wheel, or wheels, is visible through the module and dispenser viewing windows. As with the other embodiments, the indicia can take the form of color coding, shading, alpha-numerical characters and the like.

In the embodiments shown in FIGS. 28-29 and 42-43, the indicia are preferably formed around the circumferential surface 560, 660 of the indicator wheel in the form of numbers ranging from 0 to 9, with the ratchet gear on the indicator member having 10 teeth. In operation, it should be understood that the three, or more or less, indicator members can be preset to the maximum number of dosages contained within the container, with the indicia, or in this case numbers, arranged about the periphery of the indicator wheel, such that successive, sequential actuations of the container cause the indicator members to count down.

Alternatively, the indicator members are assembled such that the zero (0) of each indicator member is displayed in the viewing window to the user. The container is then actuated by the user such that the first



indicator member rotates within the housing to sequentially display the number of doses that have been dispensed from 1 to 9. Upon the tenth actuation, the indicator member completes a single revolution, by virtue of the ten teeth preferably formed about the ratchet gear which  
5 correspond to the predetermined number of actuations, and causes the second indicator member to advance one number from 0 to 1 as the first indicator member again displays a 0 such that the two members together indicate that 10 dosages have been dispensed. The first indicator member is again rotated by successive actuations until another single  
10 rotation is completed to further rotate the second indicator to reveal the 2, so as to indicate that 20 dosages have been dispensed. Upon a complete rotation of the second indicator member, corresponding to 100 actuations, the third indicator member is advanced to reveal a 1 in the viewing window with the first and second indicator members revealing a  
15 0, and so on.

As shown in FIG. 6-10, 13-18 and 20, one embodiment of the indicator assembly, including the worm, worm gear, ratchet gear and indicator member, is mounted within the module housing **130**. Similarly, the embodiments of the indicator assembly shown in FIGS. 25 and 39 are  
20 also preferably supported in a module housing **1030, 1130**. The module housing is preferably formed from a first and second cover member **136, 138, 1036, 1038, 1136, 1138** although it should be understood that a single, integral piece of material would also work, as would any plurality of members joined together. Referring to FIGS. 6-10, 30 and 39 the first  
25 cover member **136, 1136, 1036** has a vertical wall **140, 1140, 1040** defining at least a portion of the outer convex surface **134, 1034, 1134** shaped to mate with the inner surface of the housing as described above. The secondary viewing window **64, 1064, 1164** of the module is provided in the vertical wall **140, 1040, 1140** so as to be aligned with the viewing  
30 window of the housing when the module is installed therein. The viewing

window is framed by the face portion. In one embodiment, shown in FIG. 9, the first member also includes a pair of opposing bearing seats **144** formed on an inner surface of the vertical wall. The bearing seats **144** are shaped to support the ends of axle **42**. Alternatively, as shown in

5 FIGS. 27 and 30 a bearing seat or lug **1044** can be formed on each of the first and second cover members. As best shown in FIGS. 9 and 30, a post member **146, 1046** extends upwardly from a base **150, 1050** of the first member adjacent one of the bearing seats and has a socket **148, 1048** formed coaxially therein. Alternatively, as best shown in FIG. 39,

10 the base **1150** is formed as part of the second cover member and includes an opening **1148** shaped to receive the lower portion **678** of the actuator member.

Referring to FIGS. 8-9, the second cover member **138, 1038, 1138** mates with the first cover **136, 1036, 1136** to form an enclosure

15 therebetween. The second cover member includes a vertical wall **152, 1052, 1152**, a portion of which defines the concave surface **132, 1032, 1132** shaped to mate with the outer surface of the support block. An upper horizontal flange **154, 1054, 1154** extends from the vertical wall **152, 1052, 1152** and mates with the vertical wall of the second member in

20 overlying relationship therewith so as to close off the top of the module. In an alternate embodiment, the upper flange **1154** is formed as part of the first cover member. The upper flange **154, 1054, 1154** has an opening **156, 1056, 1156** formed therein which is shaped to receive the upper portion **74, 574, 674** of the post member. In one embodiment, the

25 upper surface of the flange is maintained parallel with or below the top surface of the support block so as not to interfere with the container as it is depressed toward the support block. Alternatively, as shown in FIGS. 8 and 9, the module housing is provided with a semi-circular recess **155** shaped to receive the hub as the container is actuated whereby the

30 surface **108** of the container engages the upper portion **74** of the actuator

member and the surface **108** is positioned adjacent to the surface **154** of the module housing when the valve is moved to the open position. A bottom edge **158** of the vertical wall mates with the base **150** of the first cover member to close off the bottom of the module. As shown in FIGS. 8-9, 25-27 and 30, the cover members are joined by slidably engaging vertical flanges **160, 1060** on the first cover member with grooves **162, 1062** formed on the second cover member. Inwardly extending tabs **220, 1061** snap fit into slots **222, 1063** formed in the second cover member. In the embodiment shown in FIGS. 26, 27 and 30, a tab member **1067** engages opening **1071** formed in a wall member **1069** that further defines a portion of the outer concave surface of the module housing. Alternatively, it should be understood that the first and second cover members can be joined with fasteners, adhesive and the like.

As best shown in FIGS. 7, 15, 32 and 48, when the cover members are assembled to form the module housing, the upper portion **74, 574, 674** of the post member extends through the opening in the upper flange of the first cover member and engages the top surface **108** of the container, which is inverted in the housing. Alternatively, the actuator member can be attached to the hub of the container with the locking ring as previously described. In such an embodiment, the arm member of the actuator member extends downwardly from the ring through the opening in the top of the first cover member and is positioned to selectively engage the ratchet gear. The insertion of the arm in the opening prevents the canister and attached locking ring from being rotated so as to move the arm member out of position for selective engagement with the ratchet gear.

As best shown in FIGS. 9 and 25, the lower portion **78, 578** of the post member is moveably received within the socket **148, 1048** formed in the post member **146, 1040** extending from the base of the second cover member. Alternatively, the lower portion **678** is received in the opening

1148 as shown in FIG. 39. Referring to FIGS. 9, 25 and 39, spring **88**, **588**, **688** is disposed about the lower portion **78**, **578**, **678**, and in certain embodiments includes a lower end mounted on the post member **146**, **1046**. The upper end of the spring engages the lower stop surface **86**, **586**, **686** of the post member **72**, **572**, **672**. The spring biases the post member upwardly within the housing such that the upper portion **74**, **574**, **674** protrudes through the opening and into engagement with the top surface of the container **108**.

In one embodiment, shown in FIGS. 8 and 9, the worm **40** and ratchet gear **32** are rotatably supported on the bearing seats **144** formed in the second member. Preferably, opposite ends of axle **42** are snap fitted into the bearing seats. The indicator member **50** is rotatably supported by the second cover member such that the worm gear engages the worm when the cover members are joined together. In particular, the second cover includes a pair of downwardly opening lug members **164**, **166**. The axle **56** of the indicator member is received in the first lug member **164** and a hub portion **59** positioned between the worm gear and the indicator wheel is received within the second lug member **166**. Preferably, the axle and hub are snap fitted into the lugs, but are permitted to freely rotate therein. When the cover members are joined, the indicator member, and in particular the worm gear, are trapped between the lug members and the worm.

In an alternative embodiment shown in FIGS. 25-27 and 30, the axle **556** is supported on opposite ends by the lug portion **1044** extending from each of an upper and lower cover members **1036**, **1038**. The axle **556** has a T-shaped cross-section formed as a result of a molding process, e.g., when the axle is integrally formed or molded with one or more of the module housing cover members. The shape of the axle also permits it to act as a key member when received in similarly shaped sockets formed in one or more of the lug portions. The axle extends

outwardly from the lug portion. The axle includes opposite curved surfaces **555**, **557**, as best shown in FIGS. 35-38 that provide a supporting surface for the indicator members that are rotatably mounted thereon. One of skill in the art should understand that the axle could  
5 have a circular cross-section and could be rotatably mounted to the housing. In such an embodiment, at least one of the indicator members can be integrally formed with the axle, or all of the member can be separately mounted thereon.

It should be understood that in the alternative embodiment of  
10 FIGS. 2-5, the supporting structure for the worm and ratchet, including the bearing seats or like supports, and the supporting structure for the indicator member, including the lug members, are similar to the structure provided in the module housing, but are integrally molded into the housing. Similarly, a post and socket member can be integrally molded  
15 into the bottom of the dispenser housing so as to support the actuator member and spring.

Similarly, although the indicator assembly embodiments of FIGS. 25 and 39 are shown as preferably being mounted in the indicator module, one of skill in the art should understand that the assembly,  
20 including the axle, indicator members, actuator member and spring could be mounted directly in the dispenser housing or actuator boot that supports the container. Similarly, the engagement member, or members, and non-return member, or members, could be formed in the dispenser housing that supports the container, otherwise referred to as the actuator  
25 boot.

In an alternative embodiment shown in FIG. 19, a lower portion  
172 of the outer vertical wall of the module housing is angled so as to a mate with a housing having a similar angled planar bottom surface. As shown in FIG. 19, the axis of rotation of the indicator member is oriented  
30 at an angle of approximately 45 degrees from the longitudinal axis so that

the face of the indicator wheel **60** is substantially parallel to the angled surface of the housing. A viewing window is provided in the angled surface **172** and is aligned with a similar viewing window provided in the angled wall of the dispenser housing.

5           Now referring to FIGS. 21-23, a key member **300** is shown as including a base portion **302** having a recess **304** shaped to receive the top of the container. The base portion is circular shaped and is open in the middle. The key member is mounted on the container by press fitting a circumferential flange **306**, which forms the recess, about the container  
10           such that the valve stem and hub passes through an opening **308** formed in the middle of the key member. Alternatively, the key member can be mounted to the container with adhesive or other fasteners. The key member also includes a key portion **310** extending downwardly from the base portion. The key portion is preferably configured as a circular  
15           flange member, although other shapes would also work.

          In alternative embodiments shown in FIGS. 25 and 32-33, the key member **1300** includes a mounting portion **1302**, configured as a hoop member having a plurality of ribbed portions **1304**. The mounting member **1302** is sized to fit over the end of the container such that the  
20           ribbed portions grip a portion of the container. A plurality of arm members **1306** secure a key portion **1308** to the mounting member.

          In another alternative embodiment shown in FIG. 34, the mounting member **1402** has a smaller diameter than the key portion, and is coaxially disposed with the key portion. A base member **1404** connects  
25           the mounting member and key portion. The mounting member includes a plurality of inwardly facing tab members **1410** that engage an outer tapered surface of the hub portion **106** of the container.

          In the embodiments shown in FIGS. 25 and 34, the key portion **1308, 1408** is formed as a circular flange member having a plurality of  
30           openings **1312, 1412** formed therein about the circumference thereof so

as to allow air to flow through the key member with less restriction. In the embodiment shown in FIGS. 32 and 33, the key portion **1508** includes two coaxially mounted key portions of different diameters, each with a plurality of openings **1512** to facilitate air flow therethrough.

5           The embodiment of the indicator module shown in FIG. 21 has a key entry passageway configured as a recess **312** formed in an upper surface of the module housing. Preferably, in this embodiment, the recess is formed as an arcuate shaped, or semi-circular, slot. The actuator member **314** extends upwardly from the module housing into the  
10           slot. The actuator member **314** is maintained substantially flush with or below the upper surface of the module **316**. In this way, the actuator cannot be actuated by a user's finger or the like so as to inadvertently advance the indicator member and thereby provide an inaccurate reading of the number of dosages remaining in the container, or the number  
15           dispensed therefrom.

          The shape or diameter of the key portion and corresponding entry passageway are configured so that the key portion communicates with and is received in the passageway formed in the module housing. When the container is mounted in the dispenser housing such that the valve  
20           stem is received in the well in the support block, the key portion is received in the passageway and engages the actuator member.

          In an alternative embodiment of the dispensing device, with or without an indicator module or indicator assembly, a key entry passageway can be formed directly in the dispenser housing, e.g., in a  
25           bottom portion of the dispenser housing, wherein it receives a key portion disposed on the container. It should be understood that the term "housing," as used herein, can refer to the dispenser housing, the indicator module housing, or a combination of those housings.

          In yet another alternative embodiment, the key portion and key  
30           entry passageway are reversed. In this embodiment, the key portion is

formed on the housing, i.e., the indicator module housing, or the dispenser housing if the dispensing device lacks an indicator module and/or an indicator assembly, and the key entry passageway is formed in the container. For example, the module housing, or dispenser housing, can include a ring member that is received in a ring-shaped recess formed in the hub of the container. Or, the dispenser housing or module housing can be configured to include one or more protuberances that are received in one or more recesses formed in the container.

In this way, key members having differently shaped key portions can be applied to containers holding different types of substances, such as a medicament, so as to prevent the user from mixing up the containers and dispensers. In operation, a container having a certain key member with a specific key portion can be installed only in a dispenser housing having a passageway shaped to receive that key portion. If the key portion does not fit the recess, the key ring will engage the upper surface of the module housing so as to prevent the actuation of the container relative to the dispenser housing and the attendant opening of the valve. This in turn prevents a user from installing containers having different substances in different dispensers, which could thereby adversely affect the counting of doses dispensed from the container, or the counting of the number of doses remaining therein. For example, a key member having a key portion with a thickness of 1mm and an inner diameter of 13mm is prevented from being installed in a passageway having a width of 1mm and an inner diameter of 15 mm, and vice versa.

It should be understood that the mating key member and key entry passageway can also be used with various delivery systems that do not include an indicating device, as explained above. Often, delivery systems can be configured to deliver a specific type of substance. Because a differently configured delivery system may not maximize the delivery of the intended substance, such as a medicament, it may be



important to ensure that a specific delivery system is used with a particular substance. In this way, a mating key member and key entry passageway can be mounted on one or the other of the container and housing, or similar structure, of the delivery system so as to ensure that the proper container is installed in the proper delivery system.

In the alternative embodiment of FIG. 25, the module housing includes three pairs of upstanding members **1080**, **1082** forming a slot or recess **1084** between each pair. In addition, the upstanding members of one pair **1082** are formed as channels opening towards each other. The elongated recess **1056** formed between the pair of members is shaped to receive the upper portion of the actuator member **574**. In operation, the key portion **1308** of the key member is shaped to be received in the various radially formed slots or recesses, or key entry passageways, so as to engage the actuator member disposed in the elongated recess.

When the container is moved with respect to the module housing so as to move the valve to the open position, the hub of the container nests in a recess formed between the inner upstanding member of each pair.

In the embodiment shown in FIGS. 32 and 33, three sets of three upstanding members **1180**, **1182** are provided, with each set of three having two slots **1184** formed between the members so as to be shaped to receive the two key portions **1508** of the key member **1500**. Again, one set of three members **1182** forms an elongated passageway, or recess **1056**, that is shaped to receive the actuator member. The two key portion configuration allows for multiple combinations of shapes and diameters of key portions so as to provide for a different key combination for each of the multiplicity of substances being dispensed from the various containers.

Although the circular configurations of the key portion and corresponding slots shaped to receive the key portion, as shown in the figures, are preferred since they allow the container to be rotated within

the dispenser housing about its longitudinal axis, it should be understood that the key portion and slot, or like passageway or keyhole, can be shaped in any type of mating configuration and that the mating shapes are not limited to the circular configuration shown in the figures.

5           The indicator module provides an inexpensive and accurate device for counting dosages of medicament and the like. The module can be sized for easy installation as a separate unit in most conventional inhalation housings with minimal modification of the housing, including providing a viewing window in the housing in alignment with the module  
10           viewing window and the removal of any structure formed between the support block and outer wall of the housing. In addition, the module can be installed rearwardly of the support block so as not to interfere with or otherwise impede the air flow dispensing the medicament.

15           Although the present invention has been described with reference to preferred embodiments, those skilled in the art will recognize that changes may be made in form and detail without departing from the spirit and scope of the invention. As such, it is intended that the foregoing detailed description be regarded as illustrative rather than limiting and  
20           that it is the appended claims, including all equivalents thereof, which are intended to define the scope of the invention.

**The claims defining the invention are as follows:-**

1. An aerosol dispenser for dispensing metered dosages of medicaments from a container having a valve stem extending longitudinally therefrom and moveable between a closed position and an open position, said container dispensing said metered dosage when said valve stem is moved to the open position, said aerosol dispenser comprising:

a housing adapted to support said container reciprocally moveable within said housing along a longitudinal axis, said housing having a well adapted to receive said valve stem and an exhaust port, said well communicating with said exhaust port such that said metered dosage of medicament is dispensed through said exhaust port when said valve stem is moved to the open position;

a ratchet wheel rotatably mounted in said housing and adapted to be responsive to the reciprocal movement of said container in said housing along said longitudinal axis such that said longitudinal movement of said container causes said ratchet wheel to rotate;

a worm rotatably mounted in said housing along a first rotation axis substantially perpendicular to the longitudinal axis of the movement of the container within the housing, said worm connected to said ratchet wheel such that rotation of said ratchet wheel causes said worm gear to rotate about said first rotation axis; and

an indicator member comprising a circular gear engaging said worm, said circular gear mounted in said housing about a second axis of rotation substantially perpendicular to the longitudinal axis of the movement of the container within said housing and to the first rotation axis of the worm, said indicator member comprising dosage indicia visible to the user.

2. The dispenser of claim 1 further comprising an actuator member moveably mounted in said housing, said actuator member adapted to move in response to the movement of the container within said housing along said longitudinal axis and to operably engage said ratchet wheel so as to rotate said ratchet wheel in response to the longitudinal movement of the container within said housing.

3. The dispenser of claim 2 wherein said actuator member comprises an arm adapted to selectively engage and rotate said ratchet wheel.

4. The dispenser of claim 3 wherein said actuator member further comprises a ring adapted to engage the container, said ring moveably mounted in said housing, wherein said arm extends longitudinally from said ring.



5. The dispenser of claim 2 further comprising a spring biasing said actuator member away from said selective engagement with said ratchet wheel.

6. The dispenser of claim 5 wherein said actuator member comprises a post having an end adapted to operably engage said container and an arm adapted to selectively engage said ratchet wheel, said spring disposed about and engaging said post so as to bias said actuator member away from said selective engagement with said ratchet wheel.

7. The dispenser of claim 5 wherein said housing further comprises a viewing window, said dosage indicia visible to the user through said window.

8. The dispenser of claim 1 wherein said indicator member further comprises an indicator wheel coaxially mounted with said circular gear, said indicator wheel having said dosage indicia applied to a planar face of said indicator wheel so as to be visible to the user.

9. The dispenser of claim 1 wherein said ratchet wheel and said worm are coaxially mounted within said housing.

10. The dispenser of claim 1 further comprising a module mounted in said housing, wherein said ratchet wheel, said worm and said indicator member are rotatably mounted within said module.

11. The dispenser of claim 1 wherein said housing further comprises a mouthpiece, said mouthpiece forming said exhaust port.

12. An aerosol dispenser for dispensing metered dosages of medicaments from a container having a valve stem extending longitudinally therefrom and moveable between a closed position and an open position, said container dispensing said metered dosage when said valve stem is moved to the open position, said aerosol dispenser comprising:

a housing adapted to support said container reciprocally moveable within said housing along a longitudinal axis, said housing having a well adapted to receive said valve stem and an exhaust port, said well communicating with said exhaust port such that said metered dosage of medicament is dispensed through said exhaust port when said valve stem is moved to the open position;

a worm rotatably mounted in said housing about a first rotation axis transverse to said longitudinal axis, said worm adapted to be responsive to the reciprocal movement of said container in said housing along said longitudinal axis such that said longitudinal movement of said container causes said worm to rotate about said first rotation axis; and

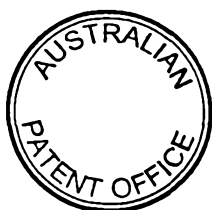

an indicator member comprising a circular gear engaging said worm, said circular gear mounted in said housing about a second axis of rotation transverse to the longitudinal axis of the movement of the container within said housing and to the first rotation axis of said worm, said indicator member comprising dosage indicia visible to the user.

5

13. The dispenser of claim 12 further comprising a ratchet wheel rotatably mounted in said housing coaxially with said worm, said ratchet wheel adapted to rotate in response to said longitudinal movement of said container with said housing.

14. The dispenser of claim 13 further comprising an actuator member moveably mounted in said housing, said actuator member adapted to move in response to the movement of the container within said housing along said longitudinal axis and to operably engage said ratchet wheel so as to rotate said ratchet wheel in response to the longitudinal movement of the container within said housing.

15. The dispenser of claim 14 wherein said actuator member further comprises a ring adapted to engage the container, said ring moveably mounted in said housing, wherein said arm extends longitudinally from said ring.

16. The dispenser of claim 14 further comprising a spring biasing said actuator member away from said selective engagement with said ratchet wheel.

17. The dispenser of claim 16 wherein said actuator member comprises a post having an end adapted to operably engage said container and an arm adapted to selectively engage the ratchet wheel, said spring disposed about and engaging said post so as to bias the actuator member away from said selective engagement with said ratchet wheel.

18. The dispenser of claim 12 wherein said indicator member further comprises an indicator wheel coaxially mounted with said circular gear, said indicator wheel having said dosage indicia applied to a face of said indicator wheel visible to the user.

19. The dispenser of claim 12 wherein said housing further comprises a viewing window, said dosage indicia visible to the user through said viewing window.

20. The dispenser of claim 12 wherein said housing further comprises a mouthpiece forming said exhaust port.

21. The dispenser of claim 12 further comprising a module mounted in said housing, wherein said worm and said indicator member are rotatably mounted within said module.

30

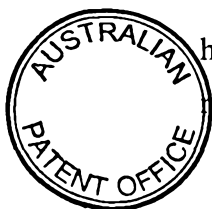

22. An apparatus for dispensing metered dosages of medicaments from a container comprising:

a housing having a longitudinally extending cavity and a well located at a bottom of said cavity, said housing comprising a mouthpiece having an exhaust port  
5 communicating with said well;

said container comprising a valve stem extending longitudinally therefrom and moveable between a closed position and an open position, said container containing a plurality of metered dosages of medicaments, said valve stem dispensing one of said plurality of said metered dosages when said valve stem is moved to the open position,  
10 said container disposed in said cavity of said housing such that said valve stem is received within said well, said container reciprocally moveable within said housing along said longitudinal extent of the cavity such that said valve stem is moved between said open and closed position by engagement with said well;

a ratchet wheel rotatably mounted in said housing;

15 an actuator member moveably mounted within said housing and comprising an arm having an end portion selectively engaging said ratchet wheel in response to the reciprocal movement of said container in said housing along said longitudinal axis such that said longitudinal movement of said container and said actuator arm causes said ratchet wheel to rotate about a first rotation axis;

20 a worm rotatably mounted in said housing along said first rotation axis transverse to the longitudinal axis of the movement of the container within the housing, said worm coaxially mounted to said ratchet wheel such that rotation of said ratchet wheel in response to the selective engagement of said arm of said actuator member causes said worm gear to rotate about said first rotation axis; and

25 an indicator member comprising a circular gear engaging said worm and a indicator wheel coaxially mounted to said circular gear, said circular gear and said indicator wheel mounted to said housing on an axle defining a second axis of rotation transverse to the longitudinal axis of the movement of the container within the housing and to the first rotation axis of the worm, said indicator wheel having a planar face  
30 comprising dosage indicia visible to the user.

23. An indicator module adapted to be received within the housing of the aerosol dispenser of claim 1, said module for indicating the number of metered dosages of medicaments dispensed from a container disposed within said dispenser housing, said



dispenser housing comprising a wall and a support block supporting said valve stem spaced apart from said wall, said indicator module comprising:

a key member adapted to be mounted to said container;

a module housing adapted to be received within said dispenser housing between  
5 said support block and said wall of said housing, wherein said module housing has a passageway shaped to receive at least a portion of said key member as said container is disposed in said dispenser housing; and

said indicator member mounted in said module housing, said indicator member comprising dosage indicia.

10 24. The indicator module of claim 23 wherein said module further comprises an actuator member adapted to engage said container, said actuator member moveable within said module housing and adapted to selectively move said indicator member in response to the longitudinal movement of said container relative to said dispenser housing.

15 25. The indicator module of claim 24 wherein said worm is rotatably mounted in said module housing about a first axis, said worm engaging said indicator member, said actuator member adapted to selectively rotate said worm in response to the longitudinal movement of the container within the housing.

20 26. The indicator module of claim 25 further comprising a spring disposed within said module housing and engaging said actuator member so as to bias said actuator member upwardly within said module housing and into engagement with said container.

27. The indicator module of claim 26 wherein said actuator member further comprises a stop surface and wherein said spring engages said stop surface so as to bias said actuator member upwardly within said enclosure.

25 28. The indicator module of claim 24 wherein said gear is mounted in said module housing about a second axis of rotation transverse to the first axis of the worm.

29. The indicator module of claim 23 wherein said module housing comprises a first and second member joined to form an enclosure.

30 30. The indicator module of claim 23 further comprising a viewing window formed in said module housing.

31. An aerosol dispenser for dispensing metered dosages of medicaments from a container having a valve stem extending longitudinally therefrom and moveable between a closed position and an open position, said container dispensing said metered



dosage when said valve stem is moved to the open position, said aerosol dispenser comprising:

a housing adapted to support said container reciprocally moveable within said housing along a longitudinal axis, said housing having a well adapted to receive said valve stem and an exhaust port, said well communicating with said exhaust port such that  
 5 said metered dosage of medicament is dispensed through said exhaust port when said valve stem is moved to the open position;

a worm rotatably mounted in said housing about a first rotation axis transverse to said longitudinal axis, said worm adapted to be responsive to the reciprocal movement of  
 10 said container in said housing along said longitudinal axis such that said longitudinal movement of said container causes said worm to rotate about said first rotation axis; and

an indicator member comprising a circular gear engaging said worm, said circular gear mounted in said housing on an axle forming a second axis of rotation transverse to the first rotation axis of the worm and non-parallel to the longitudinal axis of  
 15 the movement of the container within the housing, said indicator member comprising dosage indicia visible to the user.

32. A method for dispensing metered dosages of medicaments from a container having a valve stem extending longitudinally therefrom and moveable between a closed position and an open position, said container dispensing said metered dosage  
 20 when said valve stem is moved to the open position, said method comprising the steps of:

providing a housing having a well and an exhaust port, said well communicating with said exhaust port;

providing said container filled with a predetermined number of said metered dosages, said container moveably supported in said housing along a longitudinal axis,  
 25 said container comprising a valve stem received within said well of said housing and moveable between a closed and open position as said container is moved longitudinally within said housing, said container adapted to discharge one of said metered dosages when said valve stem is moved to the open position;

moving said container along said longitudinal axis so as to move said valve stem  
 30 to the open position and thereby discharge one of said metered dosages through said well and said port;

rotating a worm mounted in said housing a predetermined angular amount in response to said longitudinal movement of said container, said worm mounted along an





axis transverse to said longitudinal axis of said movement of said container within said housing;

providing an indicator member mounted in said housing about an axis transverse to the longitudinal axis and to said axis of said worm, said indicator member comprising a  
5 circular gear;

engaging said circular gear with said worm so as to rotate said circular gear about said axis transverse to said longitudinal axis and to said axis of said worm; and

providing indicia on said indicator member to indicate the number of metered dosages remaining in or dispensed from said container.

10 33. The method of claim 32 further comprising the steps of providing a ratchet wheel coaxially mounted to said worm in said housing and rotating said ratchet wheel so as to rotate said worm.

34. The method of claim 33 further comprising the steps of engaging an actuator member with said container such that actuator member moves in response to the  
15 movement of the container within the housing along said longitudinal axis, and engaging said ratchet wheel with said actuator member so as to rotate said ratchet wheel in response to the longitudinal movement of the container within the housing.

35. The method of claim 34 wherein said actuator member comprises an arm having an end adapted to selectively engage and rotate the ratchet wheel.

20 36. The method of claim 35 wherein said actuator member further comprises a ring adapted to engage the container, said ring moveably mounted in said housing and wherein said arm extends longitudinally from said ring.

37. The method of claim 35 further comprising a spring biasing actuator away from said selective engagement with said ratchet wheel.

25 38. The method of claim 37 further comprising a post member mounted within said housing, said spring disposed on said post member.

39. The method of claim 33 wherein said indicator member further comprises a indicator wheel coaxially mounted with said circular gear, said indicator wheel having said indicia applied to a face of the indicator wheel visible to the user.

30 40. The method of claim 33 wherein said housing further comprises a viewing window, said indicia visible to the user through said window.

41. The method of claim 33 wherein said ratchet wheel and said worm are coaxially mounted within said housing.



42. The apparatus for dispensing metered dosages of medicaments from a container according to claim 22, wherein:

said housing further comprises a support block and a wall spaced apart from said support block, said support block having a well and an orifice communicating with said well, said cavity formed above said support block;

a dose indicator module for indicating the number of metered doses remaining in or dispensed from said container, said dose indicator module comprising a module housing mounted in said dispenser housing below said container in the space between said support block and said dispenser housing wall, wherein said module housing has a passageway formed therein; and

a key member mounted to said container, said key member shaped to be received in said passageway as said valve stem of said container is mounted in said support block.

43. The apparatus of claim 42 wherein said dose indicator module further comprises said indicator member visible to a user for indicating the number of metered doses remaining in or dispensed from said container.

44. The apparatus of claim 43 wherein said dispenser housing further comprises a viewing window, wherein said indicator member is visible to the user through the viewing window.

45. The apparatus of claim 44 further comprising an actuator member comprising a post member protruding from said module housing, said post member adapted to engage said container, said actuator member moveable within said module housing and selectively engaging said ratchet wheel.

46. The apparatus of claim 45 further comprising a spring disposed within said module housing and engaging said actuator member so as to bias said post member upwardly within said module housing.

47. The apparatus of claim 42 wherein said module housing comprises a first and second member joined to form an enclosure.

48. The apparatus of claim 42 wherein said indicator module further comprises said actuator member extending into said passageway, wherein said key member engages said actuator member when said key member is received in said passageway.

49. The apparatus of claim 48 wherein said indicator module housing comprises an upper surface and wherein said actuator member does not extend beyond said upper surface when disengaged from said key member.



50. The apparatus of claim 42 wherein said passageway comprises a slot.

51. The apparatus of claim 50 wherein said slot is arcuate shaped and wherein said key member comprises a base portion mounted to said container and a key portion extending from said base portion, said key portion shaped to be received within said groove.

52. The apparatus of claim 51 wherein said key portion comprises a circular flange.

53. An aerosol dispenser, substantially as herein described with reference to any one of the embodiments of the invention shown in the accompanying drawings.

54. A method for dispensing metered dosages of medicaments from a container, said method substantially as herein described with reference to any one of the embodiments of the invention shown in the accompanying drawings.

**Dated 16 August, 2002**

**1263152 Ontario Inc**

**Patent Attorneys for the Applicant/Nominated Person**

**SPRUSON & FERGUSON**

15

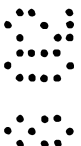
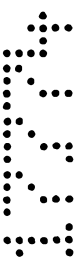

FIG. 1

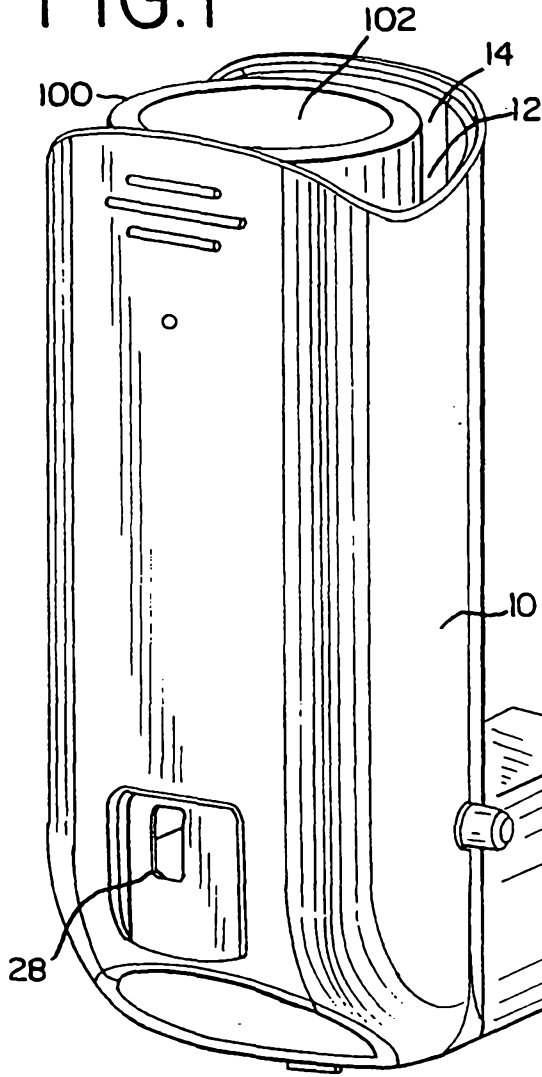

FIG. 2

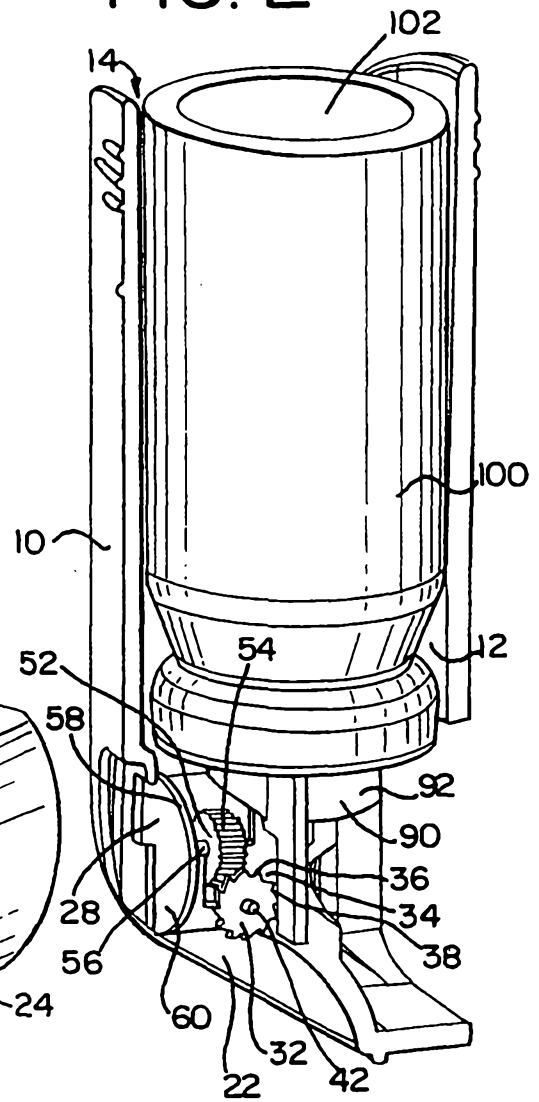

FIG. 3

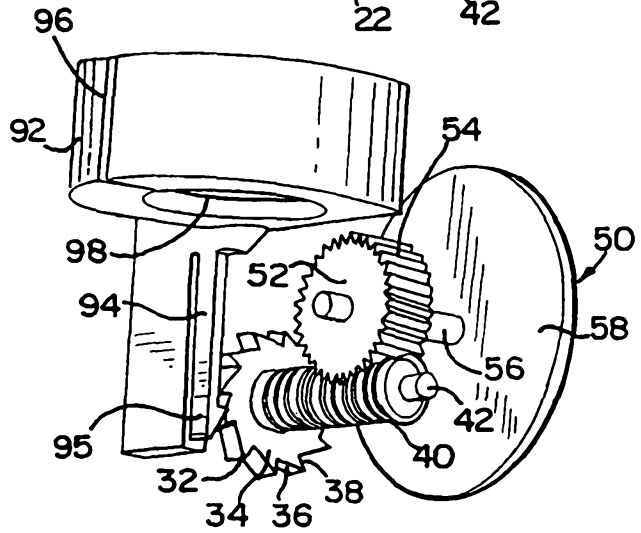

FIG. 4

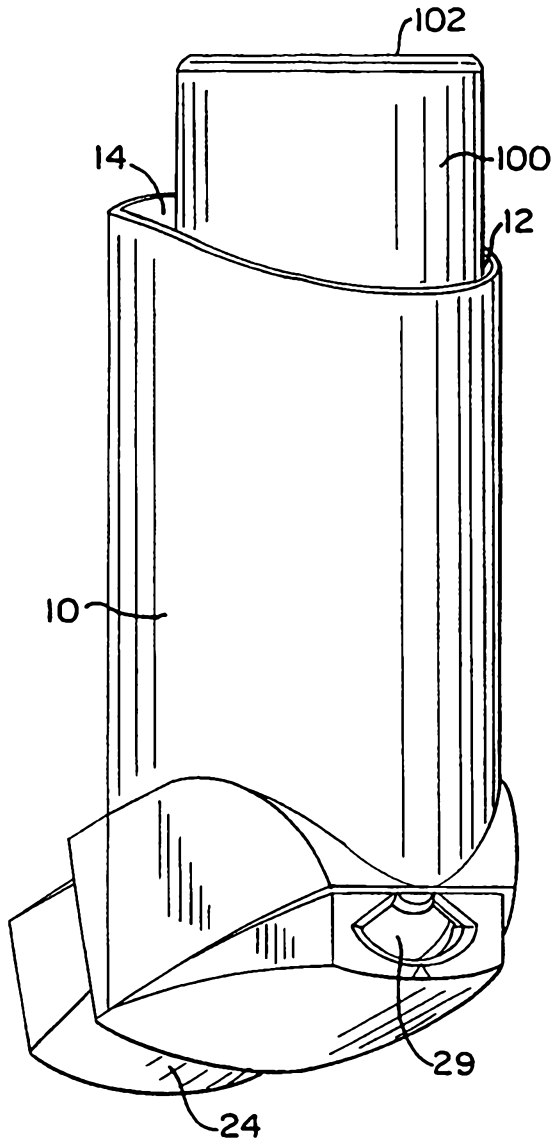

FIG. 5

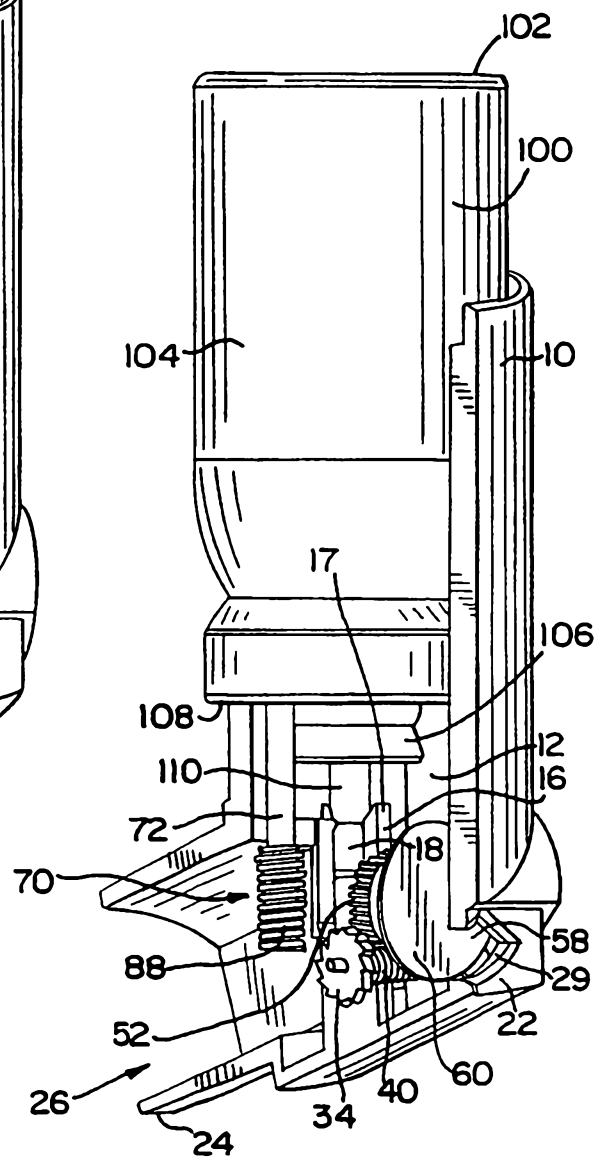

FIG. 6

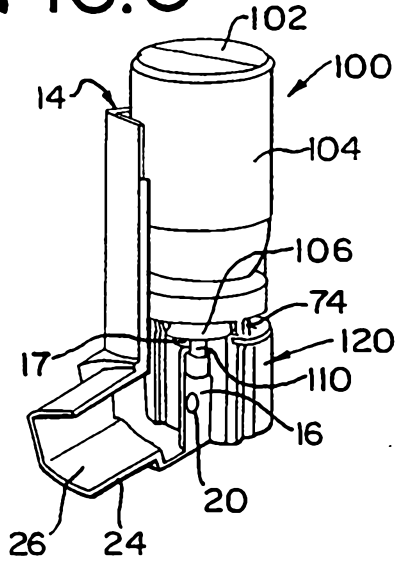

FIG. 7

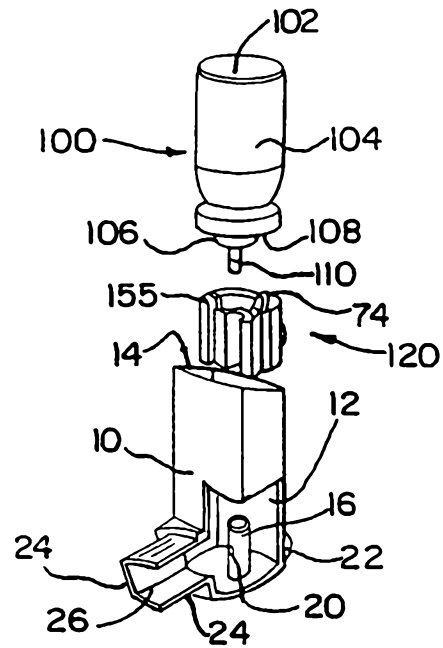

FIG. 8

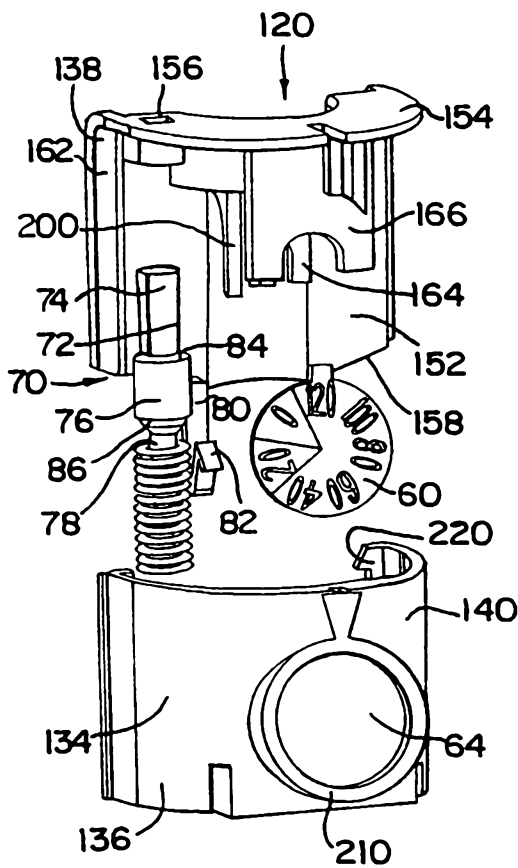

FIG. 9

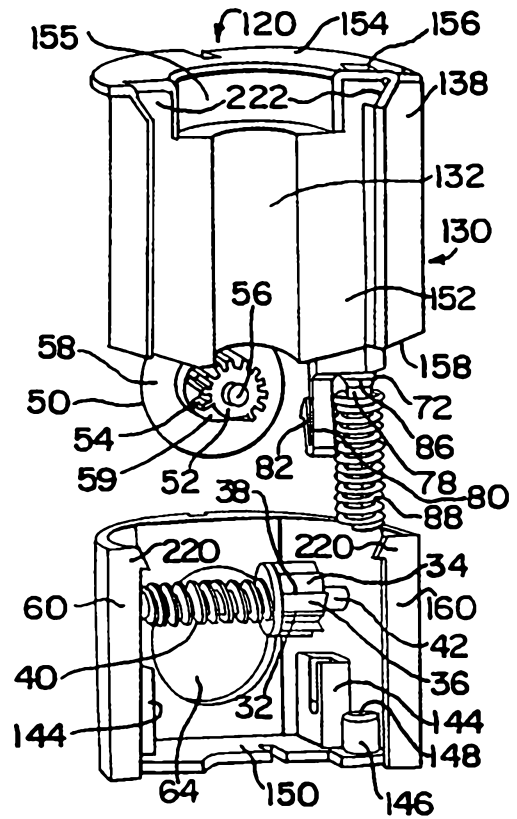

FIG. 10

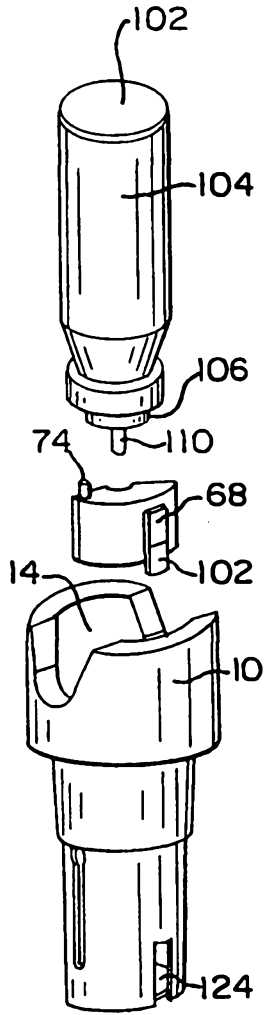

FIG. 11

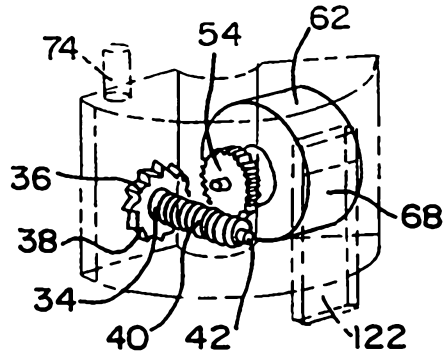
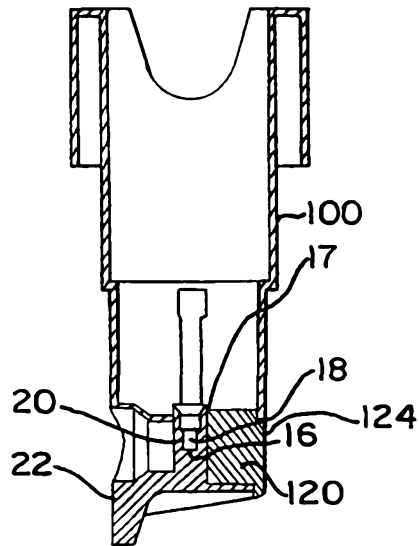

FIG. 12



5/14

FIG. 13

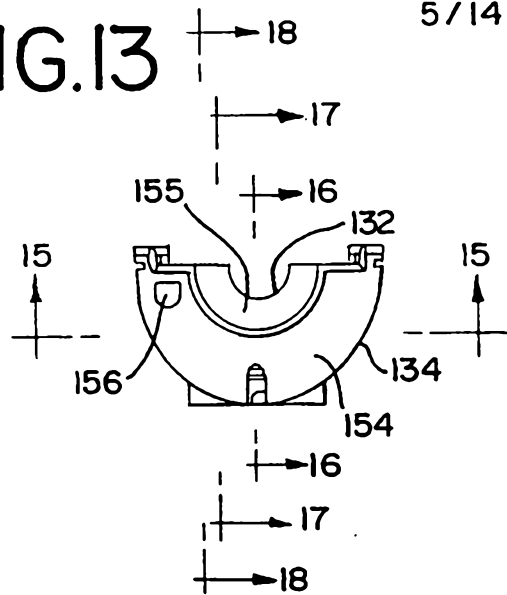

FIG. 14

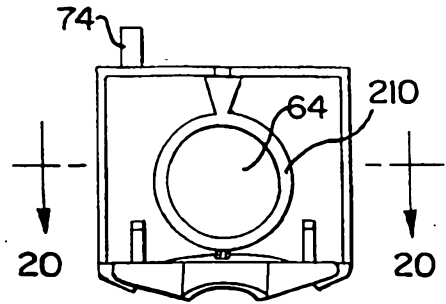

FIG. 15

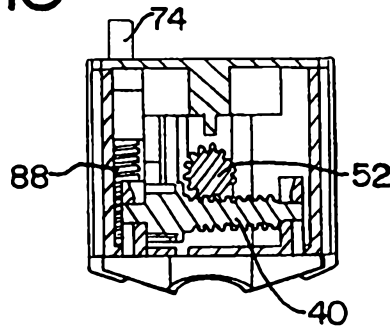

FIG. 16

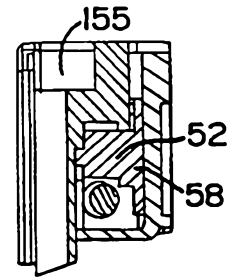

FIG. 17

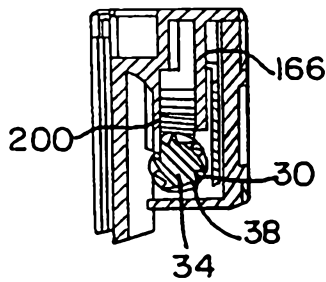

FIG. 18

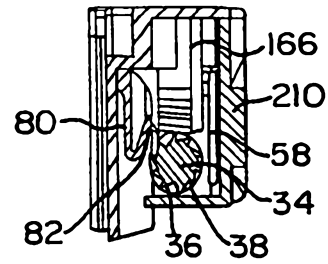

FIG. 19

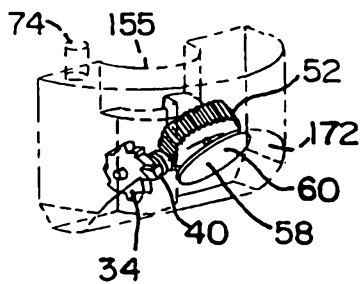

FIG. 20

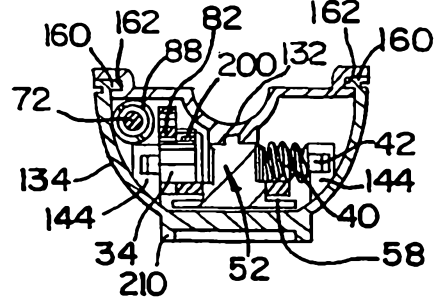



FIG. 21

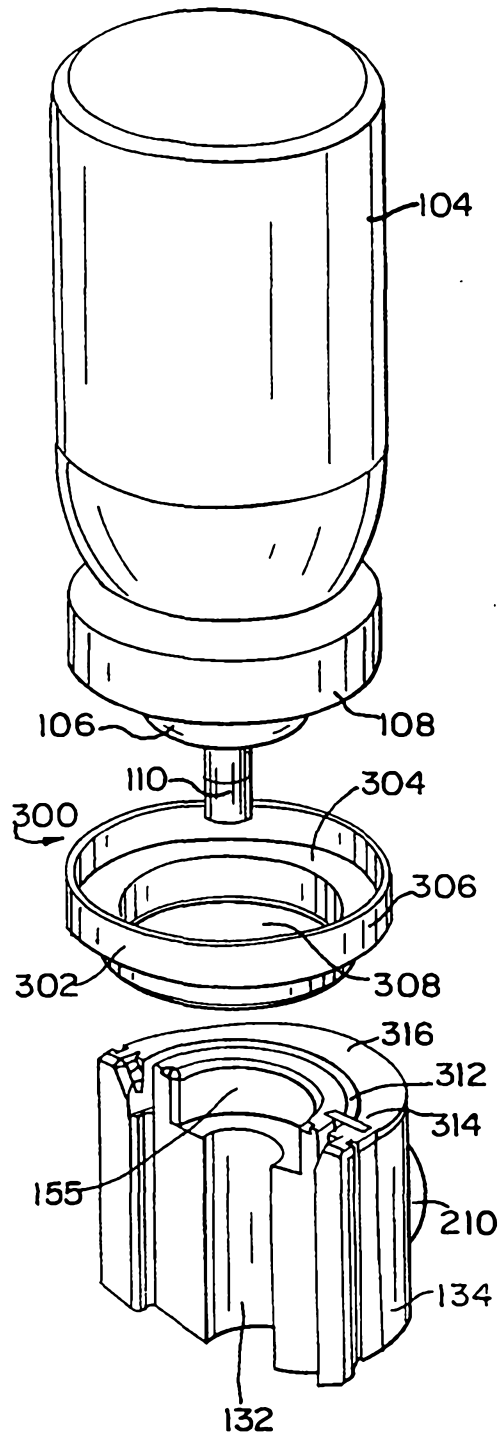

FIG. 24

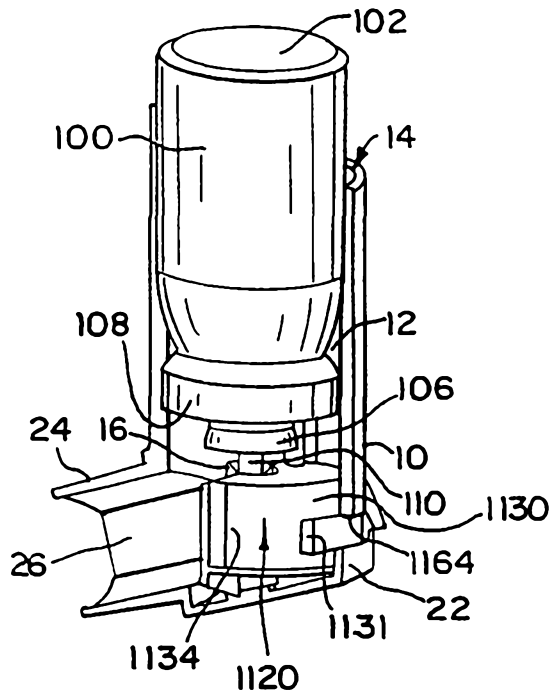

FIG. 23

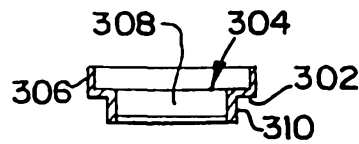

FIG. 22

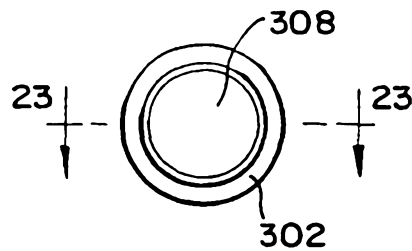

FIG. 25

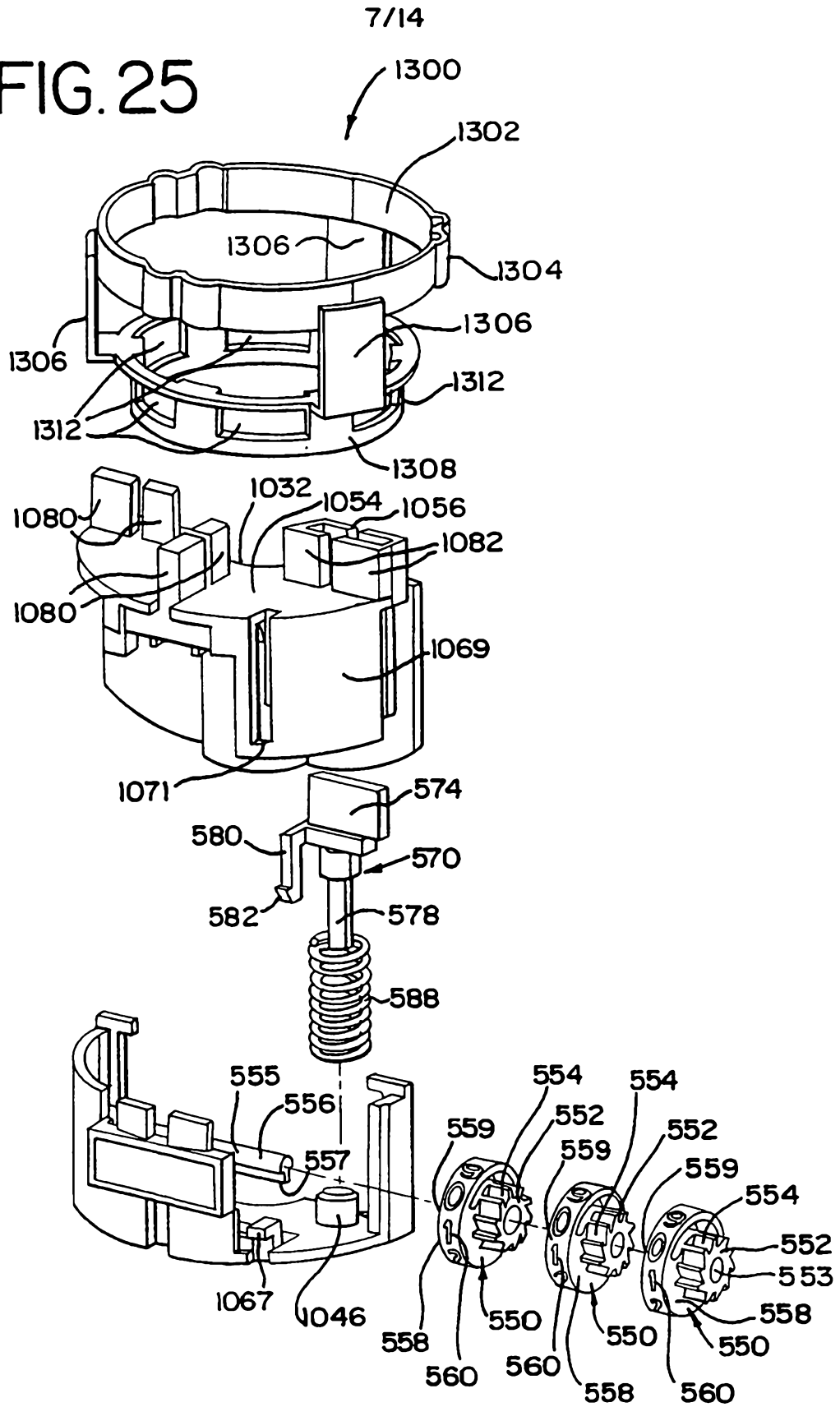

FIG. 26

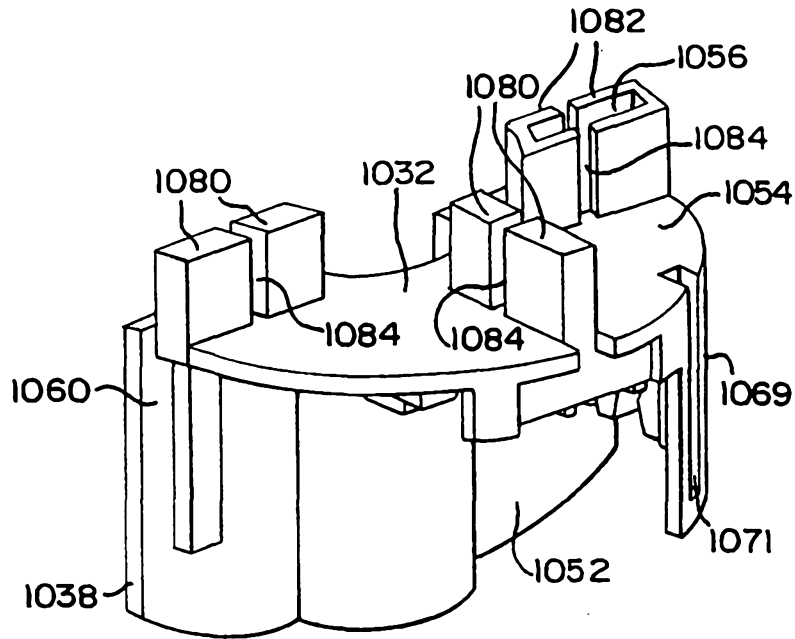
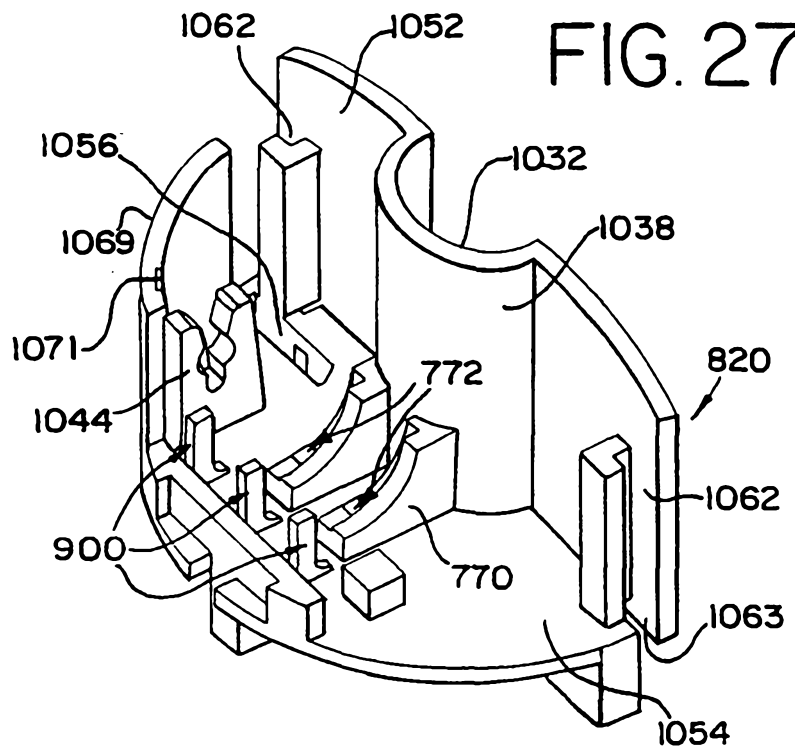

FIG. 27



9/14

FIG. 28

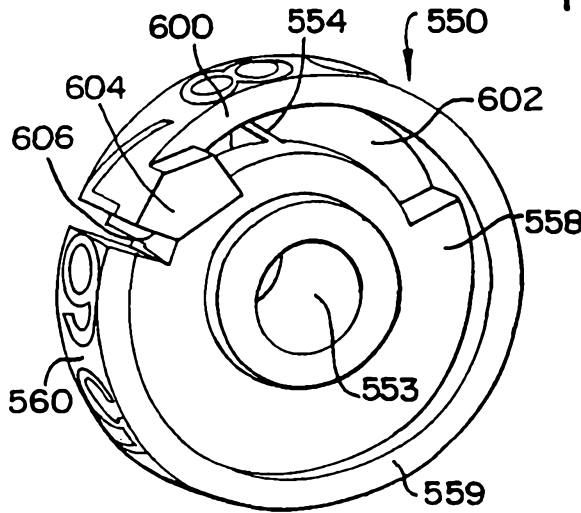

FIG. 29

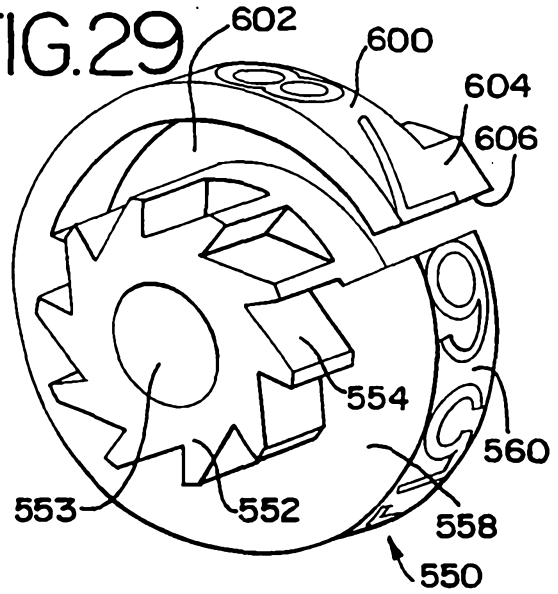

FIG. 30

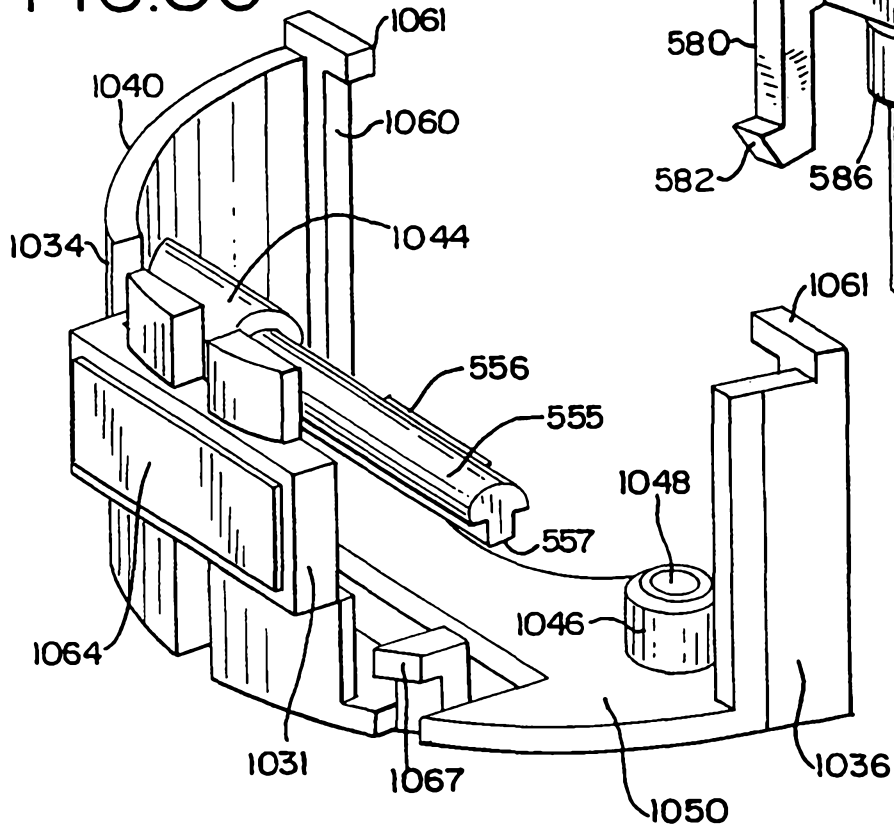
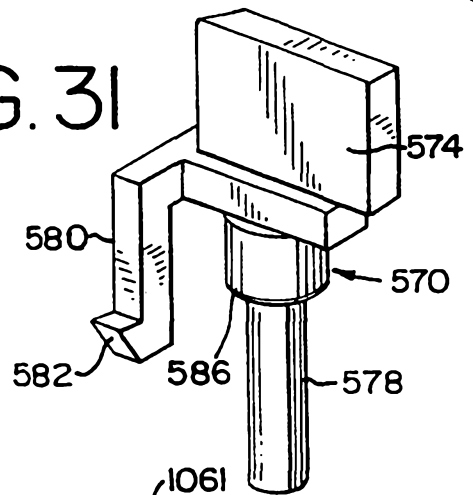

FIG. 31



10/14

FIG. 32

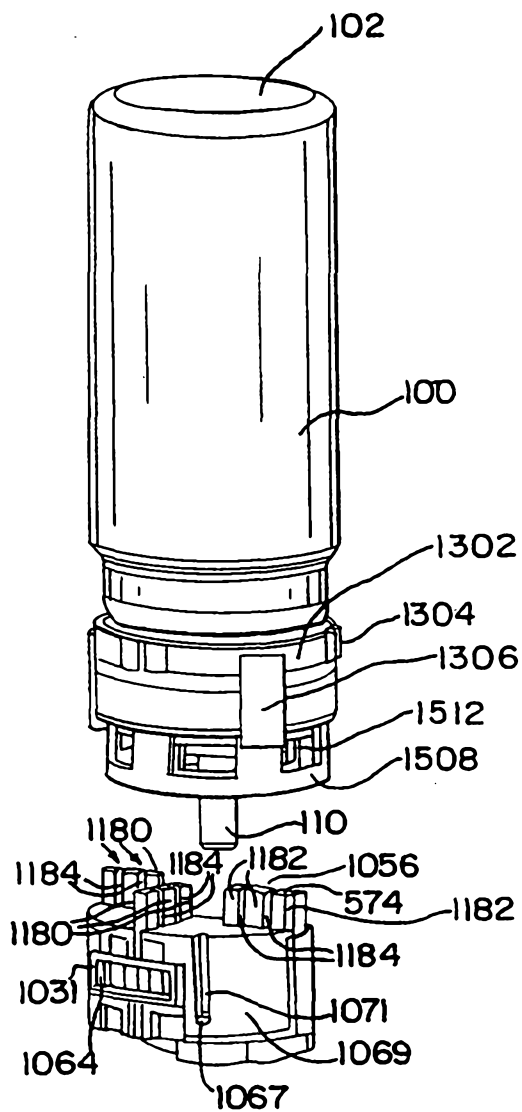

FIG. 34

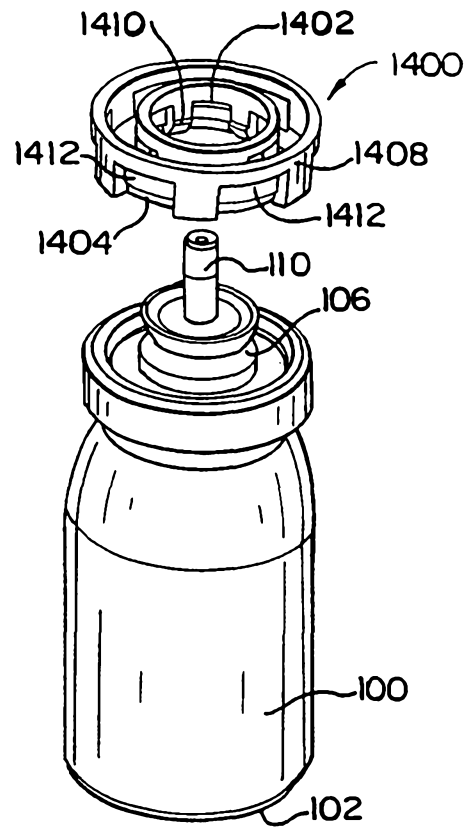
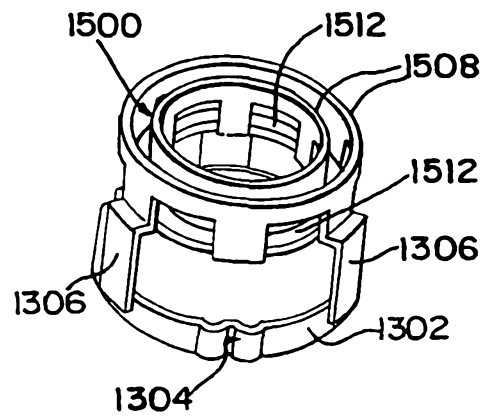

FIG. 33



11/14

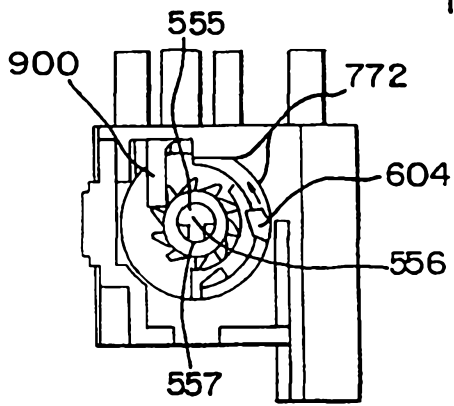

FIG. 35

FIG. 36

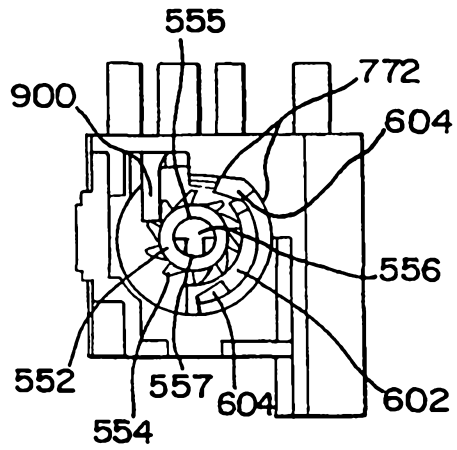

FIG. 37

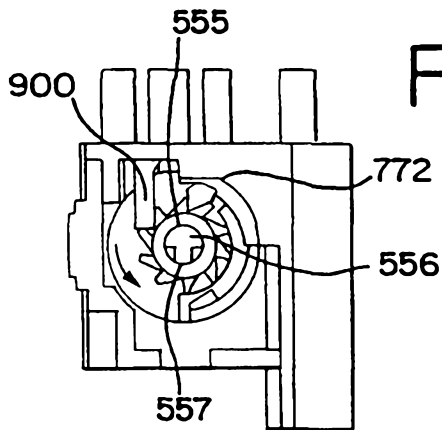
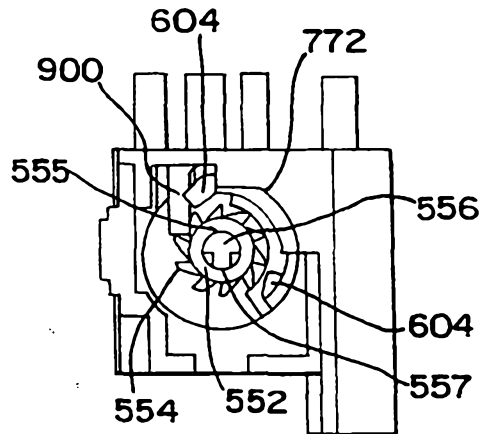

FIG. 38



12/14

FIG. 39

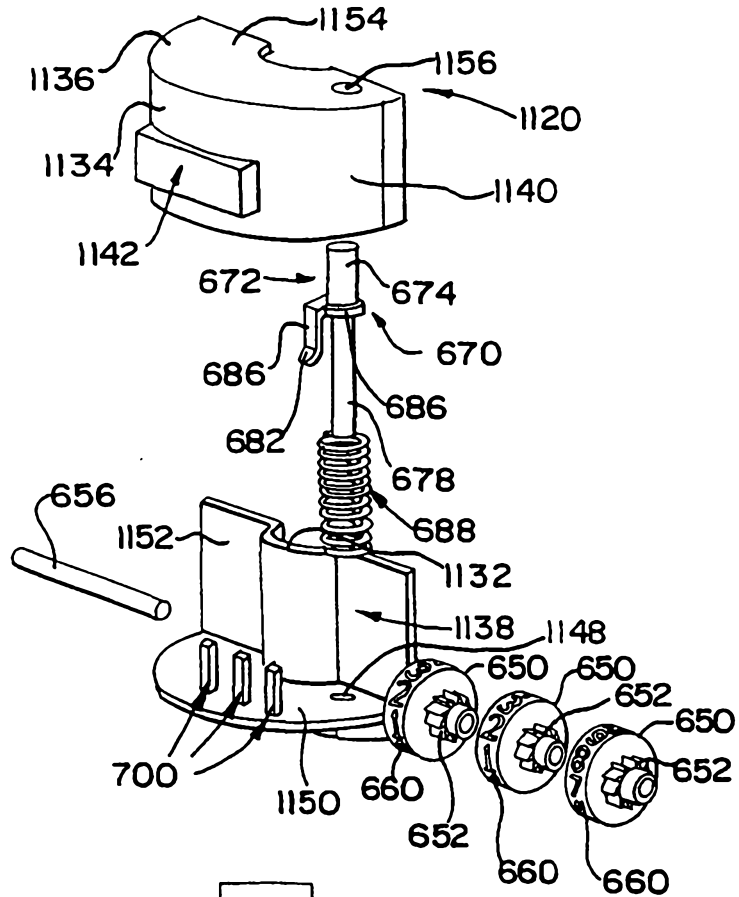
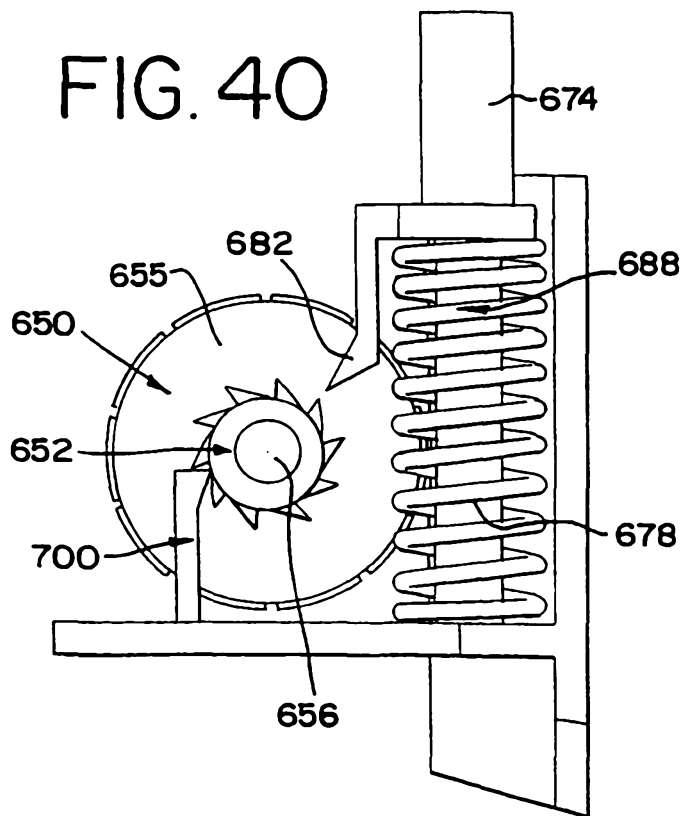

FIG. 40



13/14

FIG. 41

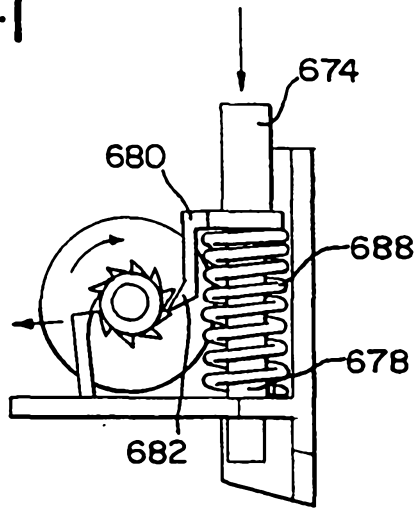

FIG. 42

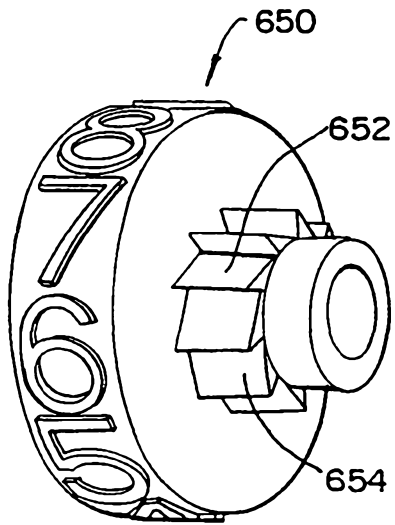

FIG. 43

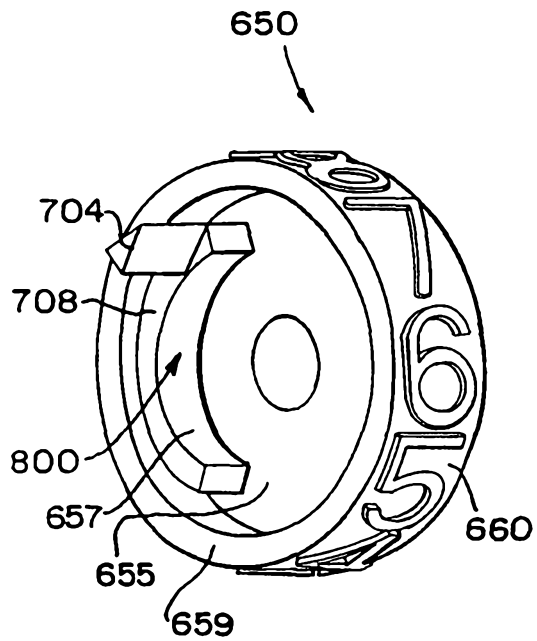



FIG. 44

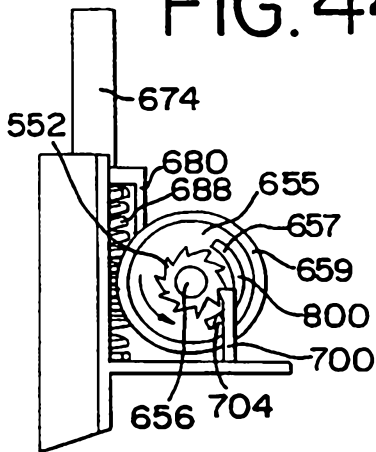

FIG. 45

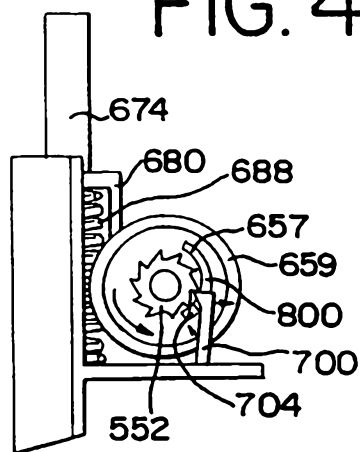

FIG. 46

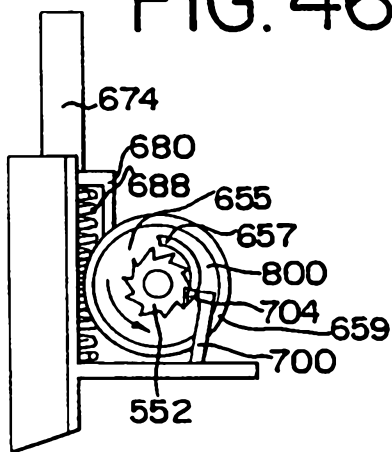

FIG. 47

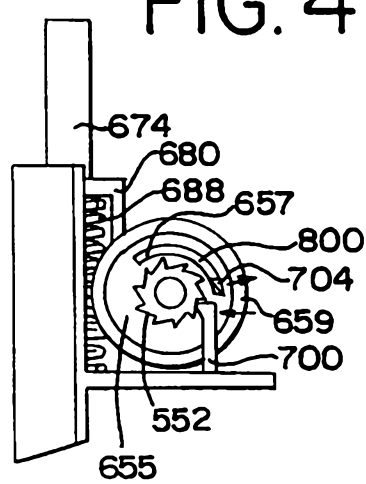

FIG. 48

