



(86) Date de dépôt PCT/PCT Filing Date: 2003/08/28
(87) Date publication PCT/PCT Publication Date: 2004/03/11
(85) Entrée phase nationale/National Entry: 2005/02/17
(86) N° demande PCT/PCT Application No.: US 2003/027105
(87) N° publication PCT/PCT Publication No.: 2004/019884
(30) Priorité/Priority: 2002/08/29 (60/406,715) US

(51) Cl.Int.⁷/Int.Cl.⁷ A61K 31/56
(71) Demandeur/Applicant:
THE REGENTS OF THE UNIVERSITY OF CALIFORNIA,
US
(72) Inventeur/Inventor:
PARHAMI, FARHAD, US
(74) Agent: CASSAN MACLEAN

(54) Titre : AGENTS ET PROCEDES POUR STIMULER LA FORMATION OSSEUSE
(54) Title: AGENTS AND METHODS FOR ENHANCING BONE FORMATION

(57) **Abrégé/Abstract:**

The present invention discloses agents and methods for inducing osteoblastic cellular differentiation, as well as the use of such agents and methods to treat patients to maintain bone mass, enhance bone formation and/or bone repair. Exemplary agents include oxysterols, alone or in combination with particular oxysterols, or other agents known to assist in bone formation. The invention further includes medicaments including oxysterols for the treatment of bone disorders, local injections of oxysterols or cells (206) and implants (202) having agents or cells (203) to facilitate bone repair.

(12) INTERNATIONAL APPLICATION PUBLISHED UNDER THE PATENT COOPERATION TREATY (PCT)

(19) World Intellectual Property
Organization
International Bureau



(43) International Publication Date
11 March 2004 (11.03.2004)

PCT

(10) International Publication Number
WO 2004/019884 A3

- (51) International Patent Classification⁷: **A61K 31/56**
- (21) International Application Number:
PCT/US2003/027105
- (22) International Filing Date: 28 August 2003 (28.08.2003)
- (25) Filing Language: English
- (26) Publication Language: English
- (30) Priority Data:
60/406,715 29 August 2002 (29.08.2002) US
- (71) Applicant (for all designated States except US): **REGENTS OF THE UNIVERSITY OF CALIFORNIA, THE** [US/US]; 1111 Franklin Street, 5th Floor, Oakland, CA 94607 (US).
- (72) Inventor; and
- (75) Inventor/Applicant (for US only): **PARHAMI, Farhad** [US/US]; 612 South Barrington Avenue, #212, Los Angeles, CA 90049 (US).
- (74) Agents: **BROWN, Marc, E.** et al.; McDermott, Will & Emery, 2049 Century Park East, Suite 3400, Los Angeles, CA 90067 (US).
- (81) Designated States (*national*): AE, AG, AL, AM, AT, AU, AZ, BA, BB, BG, BR, BY, BZ, CA, CH, CN, CO, CR, CU, CZ, DE, DK, DM, DZ, EC, EE, ES, FI, GB, GD, GE, GH, GM, HR, HU, ID, IL, IN, IS, JP, KE, KG, KP, KR, KZ, LC, LK, LR, LS, LT, LU, LV, MA, MD, MG, MK, MN, MW, MX, MZ, NO, NZ, OM, PH, PL, PT, RO, RU, SC, SD, SE, SG, SK, SL, TJ, TM, TN, TR, TT, TZ, UA, UG, US, UZ, VC, VN, YU, ZA, ZM, ZW.
- (84) Designated States (*regional*): ARIPO patent (GH, GM, KE, LS, MW, MZ, SD, SL, SZ, TZ, UG, ZM, ZW), Eurasian patent (AM, AZ, BY, KG, KZ, MD, RU, TJ, TM), European patent (AT, BE, BG, CH, CY, CZ, DE, DK, EE, ES, FI, FR, GB, GR, HU, IE, IT, LU, MC, NL, PT, RO, SE, SI, SK, TR), OAPI patent (BF, BJ, CF, CG, CI, CM, GA, GN, GQ, GW, ML, MR, NE, SN, TD, TG).
- Published:**
- with international search report
 - before the expiration of the time limit for amending the claims and to be republished in the event of receipt of amendments
- (88) Date of publication of the international search report:
1 July 2004
- For two-letter codes and other abbreviations, refer to the "Guidance Notes on Codes and Abbreviations" appearing at the beginning of each regular issue of the PCT Gazette.*

(54) Title: AGENTS AND METHODS FOR ENHANCING BONE FORMATION

(57) Abstract: The present invention discloses agents and methods for inducing osteoblastic cellular differentiation, as well as the use of such agents and methods to treat patients to maintain bone mass, enhance bone formation and/or bone repair. Exemplary agents include oxysterols, alone or in combination with particular oxysterols, or other agents known to assist in bone formation. The invention further includes medicaments including oxysterols for the treatment of bone disorders, local injections of oxysterols or cells (206) and implants (202) having agents or cells (203) to facilitate bone repair.



WO 2004/019884 A3

AGENTS AND METHODS FOR ENHANCING BONE FORMATION

GOVERNMENT SPONSORSHIP

[0001] This research is sponsored by U.S. National Institutes of Health/National Institutes of Aging, Grant No. P60 AG 10415-11, awarded by the National Institute of Health/National Institutes of Aging. The U.S. Government has certain rights in this invention.

BACKGROUND OF THE INVENTION

[0002] Normal bone remodeling, which occurs throughout the adult life in order to preserve the integrity of the skeleton, involves bone resorption by osteoclasts and bone formation by osteoblasts. Thus, any interference between the balance in bone formation and bone resorption can affect bone homeostasis, bone formation and repair.

[0003] The osteoblasts come from a pool of marrow stromal cells (also known as mesenchymal stem cells; MSC). These cells are present in a variety of tissues and are prevalent in bone marrow stroma. MSC are pluripotent and can differentiate into osteoblasts, chondrocytes, fibroblasts, myocytes, and adipocytes.

[0004] Osteoporosis is a major cause of morbidity and mortality in the elderly and the annual cost to the U.S. health care system is at least ten billion dollars. Both men and women suffer from osteoporotic bone loss with age. Decreases in sex hormones with age are thought to impact these detrimental changes. For example, osteoporosis increases in women after menopause.

[0005] Accumulating evidence suggests that the number and activity of osteoblastic cells decrease with age, however the reason for this change is not clear. Additionally, there is an increase in formation of adipocytes in osteoporotic bone marrow that appears to be at the expense of osteoblast formation. Moreover, the volume of adipose tissue in bone increases with age in normal subjects, and is substantially elevated in age-related osteoporosis, with the number of adipocytes adjacent to bone trabeculae increasing in parallel to the degree of trabecular bone loss. Based on this and similar

observations, it has been suggested that bone loss in age-related osteoporosis is at least in part due to a shift from osteoblastic differentiation to the adipocytic pathway.

[0006] Bone fracture healing is impaired in the elderly, and others demonstrating a reduced number and activity of the MSC that would normally migrate into the fracture site and allow for new bone formation to occur.

[0007] At present, the only treatments for osteoporosis are those that target bone resorption by osteoclasts. These FDA approved therapeutics include the bisphosphonates, hormone replacement therapies, such as selective estrogen receptor modulators, calcitonin, and vitamin D/calcium supplementation. However, these treatments only result in only small improvements in bone mass, and are not sufficient for total prevention or treatment of osteoporosis.

[0008] Currently, the only FDA approved anabolic agent for the treatment of osteoporosis is parathyroid hormone (PTH). PTH is currently thought to increase bone formation by inhibiting osteoblast apoptosis. PTH has been found to increase bone mass upon intermittent injection and reduce bone fracture incidence in osteoporotic patients. However, the dose must be strictly regulated since continuous treatment with PTH and/or its accumulation may have adverse systemic effects upon the patient. Additionally, PTH treatment is quite expensive. Consequently, PTH treatment has been reserved for only the most severely osteoporotic patients.

[0009] Other potential therapeutics for enhancing bone formation by osteoblasts include sodium fluoride and growth factors that have a positive effect on bone (for example insulin-like growth factors I and II and transforming growth factor beta). However, thus far these factors have had undesirable side effects.

[0010] The use of stem cells for treating bone related disorders in humans has also been examined. For example, osteogenesis imperfecta is a skeletal disease in which the patient's osteoblasts do not make collagen I in a proper form, resulting in the brittle bones. Infusion of osteoblastic progenitor stem cells from a healthy individual into a diseased individual has been shown to

improve bone density in these patients. Further, stem cells can be isolated from an individual, expanded *in vitro*, stimulated to become cartilage forming chondrocytes, and infused back into arthritic joints where the cartilage is remade.

[0011] Therefore, agents and methods for regulating bone homeostasis, bone formation and bone repair are desired.

SUMMARY OF THE INVENTION

[0012] The present invention is related to agents and methods for maintaining bone homeostasis, enhancing bone formation and/or enhancing bone repair.

[0013] More specifically, the invention may include the systemic and/or local application agents for maintaining bone homeostasis, enhancing bone formation and/or enhancing bone repair.

[0014] More specifically, the invention may include the use of agents which stimulate osteoblastic bone formation. The invention may include the use of agents which influence the differentiation of MSC into osteobalsts. Agents which may be useful in this invention to effect osteoblastic differentiation include, but are not limited to individual oxysterols, such as 22(R)-, 22(S)-, 20(S), and 25-hydroxycholesterol, pregnanolone individually or in combination with each other. Particular examples of combinations of oxysterols which may be useful in the invention are 22R- and 20S-hydroxycholesterol, as well as 22S- and 20S-hydroxycholesterol. The invention may further include any portion of the oxysterol molecule which is found to be active in effecting osteoblastic differentiation or bone formation. The invention may further include the activation of a molecule at which the oxysterols are active in effecting osteoblastic differentiation or bone formation. The invention may also include other lipid molecules or analogs designed to mimic the active portions of the above oxysterols, which would act similarly to the parent molecules, via similar mechanisms of action, and similar receptors that would have a positive impact on bone homeostasis.

[0015] The invention may include the use of agents which inhibit osteoclastic bone resorption. Agents which may be useful in this invention to effect osteoclastic bone resorption include, but are not limited to, bisphosphonates, the selective estrogen receptor modulators, calcitonin, and vitamin D/calcium supplementation. The invention may also include the use of agents which induce osteoblastic bone formation. Agents which may be useful in this invention include, but are not limited to PTH, sodium fluoride and growth factors, such as insulin-like growth factors I and II and transforming growth factor beta.

[0016] The invention may include a method of systemic delivery or localized treatment with agents for maintaining bone homeostasis, enhancing bone formation and/or enhancing bone repair. The invention may include a method of systemic delivery or localized treatment with differentiated osteoblastic cells for maintaining bone homeostasis, enhancing bone formation and/or enhancing bone repair.

[0017] In one application of the invention, the method may be applied to induce the local repair of bone, such as in periodontitis, periodontal regeneration, alveolar ridge augmentation for tooth implant reconstruction, treatment of non-union fractures. In one application of the invention, the method may be applied to treat bone related disorders, such as osteoporosis.

[0018] The invention may also include implants having coatings of substances or seeded with differentiated cells for inducing bone formation or enhancing bone repair. The invention may also include the application of substances or differentiated cells at a site where bone formation or bone repair is desired. For example, implants may include, but are not limited to pins, screws and plates that are used to immobilize a fracture, enhance bone formation, or stabilize a prosthetic implant by stimulating bone formation or bone repair.

BRIEF DESCRIPTION OF THE DRAWINGS

[0019] Figure 1 depicts a flowchart of one method according to this invention.

[0020] Figure 2 depicts two embodiments of the present invention.

[0021] Figure 3: A) is a bar graph depicting the effect of various oxysterols on alkaline phosphatase activity in M2 cells; B) is a bar graph depicting the effect of a combination of oxysterols at various doses on alkaline phosphatase activity in M2 cells; C) is a depiction of von Kossa staining of M2 cells exposed to various conditions; D) is a bar graph depicting the effect of a combination of oxysterols at various doses on calcium incorporation in M2 cells; E) is a radiogram of Northern blotting for osteocalcin mRNA in M2 cells exposed to a control or combination of oxysterols for 4 or 8 days; F) is a bar graph depicting the relative densitometric units of osteocalcin mRNA in M2 cells exposed to a control or combination of oxysterols for 4 or 8 days.

[0022] Figure 4: A) is a bar graph depicting the effect of various oxysterols at various doses on M2 cells; B) is a bar graph depicting the effect of various oxysterols at various doses on M2 cells; C) is a bar graph depicting the effect of duration of treatment with oxysterols on M2 cells; D) is a bar graph depicting the effect of various dose combinations of oxysterols on M2 cells; E) is a bar graph depicting the effect of various dose combinations of oxysterols on M2 cells.

[0023] Figure 5: A) is a bar graph depicting the effect of oxysterols and cytochrome P450 inhibitor SKF525A on M2 cells; B) is a bar graph depicting the effect of oxysterols and cytochrome P450 activator Benzylimidazole and inhibitor SKF525A M2 cells.

[0024] Figure 6 is a bar graph depicting the effect of oxysterols on reducing adipogenesis of M2 cells.

[0025] Figure 7: A) are depictions of M2 cell cultures in which adipocytes are visualized by oil Red O stain; B) is a bar graph depicting the number of adipocytes/field in each treatment group; C) is a radiogram of Northern blotting for lipoprotein lipase, adipocyte P2 gene or 18S rRNA in M2 cells exposed to a control or treatment; D) is a bar graph depicting the relative densitometric units of lipoprotein lipase, adipocyte P2 gene mRNA in M2 cells exposed to a control or treatment.

[0026] Figure 8 is a bar graph depicting the effect of synthetic LXR activators on M2 cells.

[0027] Figure 9: A) is a bar graph depicting the effect of COX-1 inhibitor or oxysterol treatment on alkaline phosphatase activity in M2 cells; B) is a bar graph depicting the effect of COX-1 inhibitor or oxysterol treatment on calcium incorporation in M2 cells; C) is a radiogram of Northern blotting for osteoclastin or 18S rRNA in M2 cells exposed to COX-1 inhibitor or oxysterol treatment; D) is a bar graph depicting the relative densitometric units of osteoclastin mRNA in M2 cells exposed to COX-1 inhibitor or oxysterol treatment; E) is a bar graph depicting the effect of PLA₂ inhibitors or oxysterol treatment on alkaline phosphatase activity in M2 cells; and F) is a bar graph depicting the effect of PLA₂ inhibitors or oxysterol treatment on calcium incorporation in M2 cells.

[0028] Figure 10: A) Western blot for pERK or ERK as expressed in M2 cells exposed to control or oxysterol treatment; B) is a bar graph depicting the effect of PD98059 or oxysterol treatment on calcium incorporation in M2 cells; C) is a bar graph depicting the number of adipocytes/field in each treatment group.

[0029] Figure 11 is a table depicting the effect of 22R + 20S oxysterol combination on mouse calvaria bone formation.

[0030] Figure 12 are representative sections of calvaria treated with a vehicle (A) or 22R + 20S oxysterol (B).

DETAILED DESCRIPTION

[0031] The present invention is related to agents and methods for maintaining bone homeostasis, enhancing bone formation and/or enhancing bone repair.

[0032] More specifically, the invention may include the systemic and/or local application of agents for maintaining bone homeostasis, enhancing bone formation and/or enhancing bone repair. Clinical indices of a method or compounds ability to maintain bone homeostasis is evidenced by improvements in bone density at different sites through out the body as assessed by DEXA scanning. Enhanced bone formation in a healing fracture is routinely assessed by regular X-ray of the fracture site at selected time

intervals. More advanced techniques for determining the above indices such as quantitative CT scanning may be used.

[0033] More specifically, the invention may include the use of agents which stimulate osteoblastic bone formation. The invention may include the use of agents which influence the differentiation of MSC into osteoblasts.

[0034] Agents which may be useful in this invention to affect osteoblastic differentiation include, but are not limited to individual or combinations of oxysterols.

[0035] Oxysterols. The ability of oxysterols to induce osteogenic differentiation and mineralization and inhibit adipogenic differentiation may provide a benefit to maintaining bone homeostasis, inducing bone formation or inducing bone repair.

[0036] Oxysterols form a large family of oxygenated derivatives of cholesterol that are present in the circulation and in tissues. Oxysterols are endogenous, oxygenated derivatives of cholesterol and are important in regulating cholesterol biosynthesis. Oxysterols are formed by autooxidation, as a secondary byproduct of lipid peroxidation, or by the action of specific monooxygenases, most of which are members of the cytochrome P450 enzyme family. Oxysterols may be derived from dietary intake. Oxysterols have been implicated in regulation of other physiologic and/or pathologic processes including cholesterol metabolism, steroid production, apoptosis, atherosclerosis, necrosis, inflammation, and immunosuppression.

[0037] Cholesterol biosynthesis has recently been shown to be involved in marrow stromal cells (MSC) differentiation, as demonstrated by the inhibitory effects of HMG-CoA reductase inhibitors, which could be reversed by mevalonate. Further, oxysterols have been demonstrated to have osteogenic potential as evidenced by their ability to induce osteoblastic differentiation, and additionally mineralization of MSC *in vitro*. Finally, oxysterols have been demonstrated to have anti-adipogenic effects and inhibit adipocyte differentiation of MSC.

[0038] The *in vitro* models used to show the osteogenic and anti-adipogenic effects of oxysterols are valid and have been used previously in demonstrating similar behaviors of other compounds including bone morphogenetic proteins (BMP). Osteoprogenitor cells including marrow stromal cells (M2 cells) used in this report, have been shown to act similarly to those present *in vivo* in animals and humans. These *in vitro* models have also previously been able to successfully predict the *in vivo* osteogenic effects of compounds such as BMP and insulin like growth factors (IGF). In addition, it has been demonstrated the osteogenic effects of the oxysterols in a bone organ culture model using mouse neonatal calvaria. This organ culture model has also previously been used to successfully predict osteogenic effect of different compounds including BMP *in vivo*. Therefore it is anticipated that based on these similar findings, oxysterols will have osteogenic effects *in vivo* in animals and humans. Demonstration of osteogenic effects of a compound in these *in vitro* and organ culture models are necessary prior to trials that would demonstrate their effects *in vivo* in animals and humans.

[0039] Agents which may be useful in this invention to effect osteoblastic differentiation include, but are not limited to individual oxysterols, such as 22(R)-, 22(S)-, 20(S), and 25-hydroxycholesterol, pregnanolone individually or in combination with each other. Particular examples of combinations of oxysterols which may be useful in the invention are 22R- and 20S-hydroxycholesterol, as well as 22S- and 20S-hydroxycholesterol. The invention may further include any portion of the oxysterol molecule which is found to be active in affecting osteoblastic differentiation or bone formation. The invention may further include the activation of a molecule at which the oxysterols are active in effecting osteoblastic differentiation or bone formation. The invention may also include other lipid molecules or analogs designed to mimic the active portions of the above oxysterols, which would act similarly to the parent molecules, via similar mechanisms of action, and similar receptors that would have a positive impact on bone homeostasis.

[0040] Mechanism of action. The mechanisms by which oxysterols are physiologically active have been examined, and oxysterols have been shown to

be active and effected by a variety of cellular pathways. First, the effects of oxysterols on osteoblastic differentiation have been demonstrated to be potentiated by a cytochrome P450 inhibitor. The effects of oxysterols on osteoblastic differentiation are also mediated by enzymes in the arachidonic acid metabolic pathway, i.e. cyclooxygenase (COX) and phospholipase A2, and ERK. Second, arachidonic acid, released for example from cellular phospholipase activity positively effects the oxysterol effect on osteoblastic differentiation. Third, prostaglandins, including prostaglandin E2 and osteogenic prostanoids, metabolized by the COX enzymes positively effects the oxysterol effect on osteoblastic differentiation. Fourth, extra-cellular signal-regulated kinase (ERK) activity is increased by oxysterols and is correlated with osteoblastic differentiation and mineralization. Therefore, these agents or agents which stimulate the mechanism of oxysterol action may also be useful in this invention.

[0041] Further, oxysterols are known to bind to and activate nuclear hormone receptors called liver X receptors (LXR) which then bind to consensus binding sites on the promoters of genes that are regulated by LXR. Additional orphan nuclear hormone receptors may also serve as for oxysterol binding sites that could mediate some of the regulatory effects of oxysterols. The invention may include the use of agents which inhibit osteoclastic bone resorption.

[0042] The invention may include a method of systemic delivery or localized treatment with agents for maintaining bone homeostasis, enhancing bone formation and/or enhancing bone repair.

[0043] The invention includes a medicament for use in the treatment of bone disorders comprising a therapeutically effective dosage of at least one oxysterol selected from the group comprising 20S-hydroxycholesterol, 22S-hydroxycholesterol, 22R-hydroxycholesterol, 25-hydroxycholesterol, or pregnanolone, or an active portion of any one of 20S-hydroxycholesterol, 22S-hydroxycholesterol, 22R-hydroxycholesterol, 25-hydroxycholesterol, or pregnanolone.

[0044] Therapeutically effective dose. A therapeutically effective dose of a agent useful in this invention is one which has a positive clinical effect on a patient as measured by the ability of the agent to improve bone homeostasis, bone formation or bone repair, as described above. The therapeutically effective dose of each agent can be modulated to achieve the desired clinical effect, while minimizing negative side effects. The dosage of the agent may be selected for an individual patient depending upon the route of administration, severity of the disease, age and weight of the patient, other medications the patient is taking and other factors normally considered by an attending physician, when determining an individual regimen and dose level appropriate for a particular patient.

[0045] By way of example, the invention may include elevating endogenous, circulating oxysterol levels over the patient's basal level. In a normal adult levels are about 10-400 nm/ml depending on age and type of oxysterol, as measured by mass spectrometry. Those skilled in the art of pharmacology could determine the dosage and route effective to raise the circulating oxysterol levels from the patient's basal level.

[0046] Dosage Form. The therapeutically effective dose of an agent included in the dosage form may be selected by considering the type of agent selected and the route of administration. The dosage form may include a agent in combination with other inert ingredients, including adjuvants and pharmaceutically acceptable carriers for the facilitation of dosage to the patient, as is known to those skilled in the pharmaceutical arts. In one embodiment, the dosage form may be an oral preparation (e.g., liquid, capsule, caplet or the like) which when consumed results in the elevated levels of the agent in the body. The oral preparation may comprise carriers including diluents, binders, time release agents, lubricants and disintegrants.

[0047] The dosage form may be provided in a topical preparation (e.g., lotion, crème, ointment, transdermal patch, or the like) for dermal application. The dosage form may also be provided in preparations for subcutaneous (such as

in a slow-release capsule), intravenous, intraperitoneal, intramuscular or respiratory application, for example.

[0048] Any one or a combination of agents may be included in a dosage form. Alternatively, a combination of agents may be administered to a patient in separate dosage forms. A combination of agents may be administered concurrent in time such that the patient is exposed to at least two agents for treatment.

[0049] Additional Agents. The invention may include treatment with an additional agent which acts independently or synergistically with at least a first agent to maintaining bone homeostasis, enhancing bone formation and/or enhancing bone repair.

[0050] Additional agents may be agents which stimulate the mechanistic pathway by which oxysterols enhance osteoblastic differentiation. Therefore, classes of agents which may be useful in this invention alone or in combination with oxysterols include, but are not limited to cytochrome P450 inhibitors, such as SKF525A. Other classes of agents useful in the invention include phospholipase activators, or arachadonic acid. Other classes of agents useful in the invention include COX enzyme activators, or prostaglandins or osteogenic prostanoids. Other classes of agents useful in the invention include ERK activators.

[0051] The invention may include combination treatments with oxysterols and other therapeutics which affect bone formation, repair or homeostasis. For example, oxysterols in combination with bisphosphonates, hormone therapy treatments, such as estrogen receptor modulators, calcitonin, and vitamin D/calcium supplementation, PTH (such as Forteo or teriparatide, Eli Lilly, sodium fluoride and growth factors that have a positive effect on bone, such as insulin-like growth factors I and II and transforming growth factor beta. Those skilled in the art would be able to determine the accepted dosages for each of the therapies using standard therapeutic dosage parameters.

[0052] The invention may include a method of systemic delivery or localized treatment with differentiated osteoblastic cells for maintaining bone

homeostasis, enhancing bone formation and/or enhancing bone repair. This treatment may be administered alone or in combination with administration of other agent(s) to the patient, as described above. Figure 1 depicts a flowchart of one method according to this invention. In this embodiment of the method, mammalian mesenchymal stem cells may be harvested, from the patient or a cell donor (100). The cells may then be treated with at least one agent to induce osteoblastic differentiation of the cells (102). The cells may then be re-administered to the patient, either systemically or at a selected site at which bone homeostasis, bone formation or bone repair is desired (104).

Additionally, the patient may be treated locally or systemically with at least one second agent which effects bone homeostasis, bone formation or bone repair (106).

[0053] In this aspect of the invention, MSC may be treated with an agent(s) to stimulate osteoblastic differentiation, as measured by any one of the increase in alkaline phosphatase activity, calcium incorporation, mineralization or osteocalcin mRNA expression, or other indicators of osteoblastic differentiation. In one embodiment of the invention MSC cells are harvested from a patient, treated with at least one oxysterol, and osteoblastic cells are administered to the patient.

[0054] The invention may include administering osteoblastically differentiated MSC systemically to the patient.

[0055] The invention may include placing osteoblastically differentiated MSC at selected locations in the body of a patient. In one embodiment of the invention, cells may be injected at a location at which bone homeostasis, formation and/or repair is desired.

[0056] In one application of the invention, the agents and methods may be applied to, but are not limited to the treatment or to slow the progression of bone related disorders, such as osteoporosis.

[0057] In applications of the invention, the agents and methods may be applied to, but are not limited to application of cells or agents to a surgical or fracture site, in periodontitis, periodontal regeneration, alveolar ridge

augmentation for tooth implant reconstruction, treatment of non-union fractures, sites of knee/hip/joint repair or replacement surgery.

[0058] Figure 2 depicts two embodiments of the present invention. In Figure 2A, the invention may include implants (200) for use in the human body comprising, a substrate having a surface (201), wherein at least the surface of the implant includes at least one oxysterol (203) in an amount sufficient to induce bone formation in the surrounding bone tissue, or implant includes mammalian cells capable of osteoblastic differentiation, or osteoblastic mammalian cells, or a combination thereof for inducing bone formation or enhancing bone repair. The implant may also For example, implants may include, but are not limited to pins, screws, plates or prosthetic joints which may be placed in the proximity of or in contact with a bone (202) that are used to immobilize a fracture, enhance bone formation, or stabilize a prosthetic implant by stimulating formation or repair of a site of bone removal, fracture or other bone injury (204).

[0059] As shown in Figure 2B, the invention may also include the application of at least one agent or differentiated cells (206) in the proximity of or in contact with a bone (202) at a site of bone removal, fracture or other bone injury (204) where bone formation or bone repair is desired.

[0060] Examples:

[0061] Materials: Oxysterols, beta-glycerophosphate (β GP), silver nitrate, oil red O were obtained from Sigma (St. Louis, MO, U.S.A.), RPMI 1640, alpha modified essential medium (α -MEM), and Dulbecco's modified Eagle's medium (DMEM) from Irvine Scientific (Santa Ana, CA, U.S.A.), and fetal bovine serum (FBS) from Hyclone (Logan, UT, U.S.A.). PD98059 was purchased from BIOMOL Research Labs (Plymouth Meeting, PA, U.S.A.), TO-901317, SC-560, NS-398, Ibuprofen, and Flurbiprofen from Cayman Chemical (Ann Arbor, MI, U.S.A.), ACA and AACOCF3 from Calbiochem (La Jolla, CA, U.S.A.), recombinant human BMP2 from R&D Systems (Minneapolis, MN, U.S.A.). Antibodies to phosphorylated and native ERKs were obtained from New

England Biolabs (Beverly, MA, U.S.A.) and troglitazone from Sankyo (Tokyo, Japan).

[0062] Cells: M2-10B4 mouse marrow stromal cell line obtained from American Type Culture Collection (ATCC, Rockville, MD, U.S.A.) was derived from bone marrow stromal cells of a (C57BL/6J x C3H/HeJ) F1 mouse, and support human and murine myelopoiesis in long-term cultures (as per ATCC) and have the ability to differentiate into osteoblastic and adipocytic cells. Unless specified, these cells were cultured in RPMI 1640 containing 10% heat-inactivated FBS, and supplemented with 1 mM sodium pyruvate, 100 U/ml penicillin, and 100 U/ml streptomycin (all from Irvine Scientific).

[0063] MC3T3-E1 mouse preosteoblastic cell line was purchased from ATCC and cultured in α -MEM containing 10% heat-inactivated FBS and supplements as described above.

[0064] C3H-10T1/2 mouse pluripotent embryonic fibroblast cells were a kindly provided by Dr. Kristina Bostrom (UCLA) and were cultured in DMEM containing 10% heat-inactivated FBS and supplements as described above. Primary mouse marrow stromal cells were isolated from male 4-6 months old C57BL/6J mice, and cultured and propagated as previously reported. Parhami, F. et al., *J. Bone Miner. Res.* 14, 2067-2078 (1999), herein incorporated by reference in its entirety.

[0065] Alkaline phosphatase activity assay: Colorimetric alkaline phosphatase (ALP) activity assay on whole cell extracts was performed as previously described.

[0066] Von Kossa and oil red O staining – Matrix mineralization in cell monolayers was detected by silver nitrate staining as previously described. Oil red O staining for detection of adipocytes was performed as previously described.

[0067] ^{45}Ca incorporation assay – Matrix mineralization in cell monolayers was quantified using the ^{45}Ca incorporation assay as previously described.

[0068] Western blot analysis – After treatments, cells were lysed in lysis buffer, protein concentrations determined using the Bio-Rad protein assay (Hercules, CA, U.S.A.), and SDS-PAGE performed as previously described. Probing for native and phosphorylated ERKs was performed as previously reported.

[0069] RNA isolation and Northern blot analysis – Following treatment of cells under appropriate experimental conditions, total RNA was isolated using the RNA isolation kit from Stratagene (La Jolla, CA, U.S.A.). Total RNA (10 mg) was run on a 1% agarose/formaldehyde gel and transferred to Duralon-UV membranes (Stratagene, CA, U.S.A.) and cross-linked with UV light. The membranes were hybridized overnight at 60 degree C with ³²P-labeled mouse osteocalcin cDNA probe, mouse lipoprotein lipase (LPL), mouse adipocyte protein 2 (aP2) PCR-generated probes, human 28S or 18S rRNA probes obtained from Geneka Biotechnology (Montreal, Quebec, Canada) and Maxim Biotech (San Francisco, CA, U.S.A.), respectively. The PCR products were generated using primer sets synthesized by Invitrogen (Carlsbad, CA, U.S.A.) with the following specifications: mouse aP2 gene (accession no. M13261); sense (75-95) 5'-CCAGGGAGAACCAAAGTTGA-3', antisense (362-383) 5'-CAGCACTCACCCACTTCTTTC-3', generating a PCR product of 309 base pairs. Mouse LPL (accession no. XM_134193); sense (1038-1058) 5'-GAATGAAGAAAACCCAGCA-3', antisense (1816-1836) 5'-TGGGCCATTAGATTCTCAC-3', generating a PCR product of 799 base pairs. The PCR products were gel-purified and sequenced by the UCLA sequencing core, showing the highest similarity to their respective GenBank entries. Following hybridization, the blots were washed twice at room temperature with 2X SSC+0.1%SDS, and then twice at 60 degree C with 0.5X SSC+0.1% SDS, and exposed to X-ray film. The extent of gene induction was determined by densitometry.

[0070] Statistical Analyses - Computer-assisted statistical analyses were performed using the StatView 4.5 program. All p values were calculated using ANOVA and Fisher's projected least significant difference (PLSD) significance test. A value of p<0.05 was considered significant.

[0071] Example A: Osteogenic effects of oxysterols in MSC.

[0072] Test 1: M2 cells at confluence were treated with control vehicle (C), or 10 μ M oxysterols, in an osteogenic medium consisting of RPMI 1640 to which 10% fetal bovine serum (FBS), 50 μ g/ml ascorbate and 3 mM beta-glycerophosphate (β GP) were added. After 3 days of incubation, alkaline phosphatase (ALP) activity was determined in cell homogenates by a colorimetric assay. Results from a representative of five experiments are shown, reported as the mean \pm SD of quadruplicate determinations, normalized to protein concentration (* $p < 0.01$ for C vs. oxysterol-treated cells). Figure 3A is a bar graph depicting the effect of various oxysterols on alkaline phosphatase activity in M2 cells.

[0073] M2 cells at confluence were treated in osteogenic medium with control vehicle (C) or a combination of 22R and 20S oxysterols, at the indicated concentrations. ALP activity was measured after 3 days as described above. Results from a representative of four experiments are shown, reported as the mean \pm SD of quadruplicate determinations, normalized to protein concentration (* $p < 0.01$ for C vs. oxysterols). Figure 3B is a bar graph depicting the effect of a combination of oxysterols at various doses on alkaline phosphatase activity in M2 cells.

[0074] M2 cells at confluence were treated in osteogenic medium with control vehicle or 5 μ M oxysterols, alone or in combination as indicated. After 14 days, mineralization was identified by a von Kossa staining, which appears black. Figure 3C is a depiction of von Kossa staining of M2 cells exposed to various conditions.

[0075] M2 cells were treated with control vehicle (C) or a combination of 22R and 20S oxysterols at increasing concentrations. After 14 days, matrix mineralization in cultures was quantified using a ^{45}Ca incorporation assay. Results from a representative of four experiments are shown, reported as the mean \pm SD of quadruplicate determinations, normalized to protein concentration (* $p < 0.01$ for C vs. oxysterol-treated cultures). Figure 3D is a bar

graph depicting the effect of a combination of oxysterols at various doses on calcium incorporation in M2 cells.

[0076] M2 cells at confluence were treated with control vehicle (C) or a combination of 22R and 20S oxysterols (5 μ M each) in osteogenic medium. After 4 and 8 days, total RNA from duplicate samples was isolated and analyzed for osteocalcin (Osc) and 28S rRNA expression by Northern blotting as described. Figure 3E is a radiogram of Northern blotting for osteocalcin mRNA in M2 cells exposed to a control or combination of oxysterols for 4 or 8 days. Figure 3F is a bar graph depicting the relative densitometric units of osteocalcin mRNA in M2 cells exposed to a control or combination of oxysterols for 4 or 8 days. Data from densitometric analysis of the Northern blot is shown in (F) as the average of duplicate samples, normalized to 28S rRNA.

[0077] Results Test 1: In cultures of MSC, stimulation of alkaline phosphatase activity, osteocalcin gene expression and mineralization of cell colonies are indices of increased differentiation into osteoblast phenotype. Specific oxysterols, namely 22(R)-hydroxycholesterol (22R), 20(S)-hydroxycholesterol (20S), and 22(S)-hydroxycholesterol (22S), induced alkaline phosphatase activity, an early marker of osteogenic differentiation, in pluripotent M2-10B4 murine MSC (M2). 7-ketocholesterol (7K) did not induce alkaline phosphatase activity in these cells.

[0078] The induction of alkaline phosphatase activity was both dose- and time-dependent at concentrations between 0.5-10 μ M, and showed a relative potency of 20S>22S>22R. A 4-hour exposure to these oxysterols followed by replacement with osteogenic medium without oxysterols was sufficient to induce alkaline phosphatase activity in M2 cells, measured after 4 days in culture.

[0079] Individual oxysterols (22R, 20S and 22S) at concentrations between 0.5-10 μ M were unable to induce mineralization or osteocalcin gene expression after as many as 14 days of treatment (data not shown). However, alkaline phosphatase activity (Fig. 3B), robust mineralization (Fig. 3C and D) and

osteocalcin gene expression (Fig. 3E and F) were all induced in M2 cultures by a combination of the 22R+20S or 22S+20S oxysterols.

[0080] Test 2: M2 cells were grown in RPMI medium containing 10% fetal bovine serum (FBS). At confluence, the cells were treated in RPMI containing 5% FBS plus ascorbate at 50 µg/ml and β-glycerophosphate at 3 mM to induce osteoblastic differentiation. Adipogenic differentiation was induced by treating the cells in growth medium plus 10 nM troglitazone. A vehicle (C) or oxysterol treatment was applied to cells in a variety of doses (in µM): 20S-Hydroxycholesterol, 25-Hydroxycholesterol, 22R-Hydroxycholesterol; 22S-Hydroxycholesterol; 7-ketocholesterol. Cells were always treated at 90% confluence. After 4 days, alkaline phosphatase activity was determined in whole cell lysates and normalized to protein. Alternatively, MSC cultures were prepared and treated with oxysterols as described above. Cells were treated at 90% confluence with the combination of 22R-Hydroxycholesterol and 20S-Hydroxycholesterol, each at 5 µM, for 4 to 96 hours. The oxysterols were removed and fresh media without oxysterols was added for a total duration of 96 hours. Alkaline phosphatase activity was measured in whole cell extracts and normalized to protein.

[0081] Results Test 2: Figure 4A is a bar graph depicting the effect of various oxysterols at various doses on M2 cells after 4 days of exposure. Oxysterols induced alkaline phosphatase activity, an early marker of osteoblastic differentiation.

[0082] Figure 4B is a bar graph depicting the effect of various oxysterols at various doses on M2 cells after 24 hours of treatment. Cells were treated at 90% confluence with vehicle (C), or oxysterols 22R-Hydroxycholesterol or 20S-Hydroxycholesterol, each at 5 µM, alone or in combination. After 24 hours, the cells were rinsed and media replaced with out oxysterols. After 4 days, alkaline phosphatase activity was measured in whole cell extracts and normalized to protein. Alkaline phosphatase activity was induced several fold after only 24 hours of treatment with the oxysterols.

[0083] Figure 4C is a bar graph depicting the effect of duration of treatment with oxysterols on M2 cells. Treatment with a combination oxysterols (22R-hydroxycholesterol and 20S-hydroxycholesterol, each at 5 μ M induced alkaline phosphatase activity after 4-96 hours of treatment as measured 4 days post-treatment.

[0084] Figure 4D is a bar graph depicting the effect of various dose combinations of oxysterols on M2 cells. The effect of the combination oxysterols on M2 cells was dose-dependent for the induction of alkaline phosphatase activity.

[0085] Figure 4E is a bar graph depicting the effect of various dose combinations of oxysterols on M2 cells. Treatment with the combination doses of 22R-and 20S-Hydroxycholesterol. After 10 days, 45 Ca incorporation was measured to assess bone mineral formation, and normalized to protein. The effect of combination oxysterols on M2 cells was dose-dependent for the induction of bone mineral formation as well.

[0086] Example B: Cytochrome P450 inhibition of oxysterol effects. M2 cells were treated at 90% confluence with vehicle (C), or oxysterols 20S-Hydroxycholesterol or 22S-Hydroxycholesterol at (0.5 μ M) or (1 μ M), in the absence or presence of cytochrome P450 inhibitor (SKF525A 10 μ M (+)). MSC cultures were also treated at 90% confluence with vehicle (C), or 20S-Hydroxycholesterol (2 μ M), in the absence or presence of cytochrome P450 activator (Benzylimidazole 50 μ M) or SKF525A (10 μ M). After 4 days, alkaline phosphatase activity was measured in whole cell extracts and normalized to protein.

[0087] Results Example B: Figure 5A is a bar graph depicting the effect of oxysterols and cytochrome P450 inhibitor SKF525A on marrow stromal cells. After 4 days, alkaline phosphatase activity was measured in whole cell extracts and normalized to protein. The use of the cytochrome P450 inhibitor potentiated the osteogenic effects of the oxysterols, suggesting that oxysterols are metabolized and inhibited by the cytochrome P450 enzymes.

[0088] Figure 5B is a bar graph depicting the effect of oxysterols and cytochrome P450 activator Benzylimidazole and inhibitor SKF525A on M2 cells. Treatment with stimulator of cytochrome P450 enzymes, Benzylimidazole, inhibited oxysterol effects, perhaps through enhancing oxysterol degradation.

[0089] Example D: Inhibition of adipogenesis in MSC by oxysterols.

Adipogenesis of adipocyte progenitors including MSC is regulated by the transcription factor peroxisome proliferator activated receptor γ (PPAR γ), that upon activation by ligand-binding, regulates transcription of adipocyte specific genes.

[0090] Test 1: M2 cells at 90% confluence were treated with vehicle (C), PPAR- γ activator, troglitazone 10 μ M (Tro), alone or in combination with 10 μ M oxysterols 20S-, 22R-, or 25S-hydroxycholesterol. After 8 days, adipocytes were identified by oil Red O staining and quantified by counting under a phase contrast microscope. Figure 6A is a bar graph depicting the effect of oxysterols on reducing adipogenesis of MSC. The osteogenic oxysterols inhibited adipogenesis in MSC cultures.

[0091] Test 2: (A) M2 cells at confluence were treated in RPMI containing 10% FBS with control vehicle or 10 μ M troglitazone (Tro) in the absence or presence of 10 μ M 20S or 22S oxysterols. After 10 days, adipocytes were visualized by oil Red O staining and quantified by light microscopy, shown in (B). Data from a representative of four experiments are shown, reported as the mean SD of quadruplicate determinations ($p < 0.001$ for Tro vs. Tro+20S and Tro+22S). (C) M2 cells were treated at confluence with 10 μ M Tro, alone or in combination with 10 μ M 20S oxysterol. After 10 days, total RNA was isolated and analyzed for lipoprotein lipase (LPL), adipocyte P2 gene (aP2) or 18S rRNA expression by Northern blotting as described (Ref). Data from densitometric analysis of the Northern blot is shown in (D) as the average of duplicate samples, normalized to 18S rRNA.

[0092] Figure 7: A) are depictions of M2 cell cultures in which adipocytes are visualized by oil Red O stain; B) is a bar graph depicting the number of

adipocytes/field in each treatment group; C) is a radiogram of Northern blotting for lipoprotein lipase, adipocyte P2 gene or 18S rRNA in M2 cells exposed to a control or treatment; D) is a bar graph depicting the relative densitometric units of lipoprotein lipase, adipocyte P2 gene mRNA in M2 cells exposed to a control or treatment.

[0093] In M2 cells treated with Tro (PPAR γ activator, Troglitazone (Tro)) to induce adipogenesis, 20S, 22S, and 22R, alone or in combination, inhibited adipogenesis. The relative anti-adipogenic potency of these oxysterols was similar to their relative potency in stimulating alkaline phosphatase activity in M2 cells, with 20S>22S>22R. Similar to its lack of osteogenic effect, 7K was also unable to inhibit adipogenesis in M2 cells (data not shown). Inhibition of adipogenesis was also assessed by an inhibition of the expression of the adipogenic genes lipoprotein lipase (LPL) and adipocyte P2 gene (aP2) by 20S (Fig. 7C and D). Inhibitory effects of these oxysterols on adipogenesis were also demonstrated using C3H10T1/2 and primary mouse MSC, in which adipogenesis was induced either by Tro or a standard adipogenic cocktail consisting of dexamethasone and isobutylmethylxanthine.

[0094] Example E: Mechanism of oxysterol effects. Liver X receptors (LXR) are nuclear hormone receptors that in part mediate certain cellular responses to oxysterols. LXR α is expressed in a tissue specific manner, whereas LXR β is ubiquitously expressed. By Northern blot analysis we demonstrated the expression of LXR β , but not LXR α , in confluent cultures of M2 cells (data not shown). In order to assess the possible role of LXR in mediating the effects of osteogenic oxysterols, we examined whether activation of LXR β by the pharmacologic LXR ligand TO-901317 (TO) had effects similar to those exerted by 22R and 20S in M2 cells.

[0095] Test 1: TO at 1-10 μ M caused a dose-dependent inhibition of alkaline phosphatase activity in M2 cells (C: 18 ± 2 ; ligands used at 10 μ M: 22R= 45 ± 5 ; 20S= 140 ± 12 ; and TO= 3 ± 0.5 activity units/mg protein \pm SD; $p < 0.01$ for C vs. all ligands). Furthermore, TO treatment did not induce osteocalcin gene expression or mineralization after 10 days. Therefore, the osteogenic effects of

the oxysterols on M2 cells thus far appears to be independent of the LXR-beta receptor, as suggested by the potent osteogenic activity of the non-LXR oxysterol ligand 22S and the lack of osteogenic effects in response to the LXR ligand TO.

[0096] Test 2: MSC cells at 90% confluence were treated with vehicle (C), or two unrelated LXR ligands (TO and GL at 1-4 μ M), or 22R-hydroxycholesterol (10 μ M). After 4 days, alkaline phosphatase activity was measured in whole cell lysates and normalized to protein. Figure 8 is a bar graph depicting the effect of LXR activators on inhibiting osteoblastic differentiation of MSC. LXR-beta is present in MSC, however the osteogenic effects of the oxysterols described above appear not to be through LXR-beta since treatment with specific activators of LXR inhibited osteoblastic differentiation and mineralization of those cells.

[0097] Example F: Mechanism of osteogenic activity of oxysterols in MSC. Mesenchymal cell differentiation into osteoblasts is regulated by cyclooxygenase (COX) activity. COX-1 and COX-2 are both present in osteoblastic cells, and appear to be primarily involved in bone homeostasis and repair, respectively. Metabolism of arachidonic acid into prostaglandins, including prostaglandin E2 (PGE2), by the COXs mediates the osteogenic effects of these enzymes. COX products and BMP2 have complementary and additive osteogenic effects.

[0098] (A) M2 cells at confluence were pretreated for 4 hours with control vehicle (C) or 10 μ M COX-1 inhibitor SC-560 (SC) in osteogenic medium as described earlier. Next, a combination of 22R and 20S oxysterols (RS, 2.5 μ M each) were added in the presence or absence of SC as indicated. After 3 days, ALP activity was measured as described earlier. Data from a representative of three experiments are shown, reported as the mean \pm SD of quadruplicate determinations, normalized to protein concentration ($p < 0.001$ for RS vs. RS+SC). (B) M2 cells were treated as described in (A) and after 10 days matrix mineralization in cultures was quantified by a 45 Ca incorporation assay as described earlier. Results from a representative of three experiments are

shown, reported as the mean \pm SD of quadruplicate determinations, normalized to protein concentration. (C) M2 cells were pretreated with 20 μ M SC for 4 hours, followed by the addition of RS in the presence or absence of SC as described above. After 8 days, total RNA was isolated and analyzed for osteocalcin (Osc) and 18S rRNA expression by Northern blotting as previously described. Data from densitometric analysis of the Northern blot is shown in (D) as the average of duplicate samples, normalized to 18S rRNA. (E) M2 cells at confluence were pretreated for 2 hours with control vehicle (C), or PLA₂ inhibitors ACA (25 μ M) and AACOCF3 (AAC, 20 μ M), in osteogenic medium. Next, a combination of 22R and 20S oxysterols (RS, 2.5 μ M) was added in the presence or absence of the inhibitors as indicated. After 3 days, ALP activity was measured as previously described. Data from a representative of three experiments are shown, reported as the mean \pm SD of quadruplicate determinations, normalized to protein concentration ($p < 0.01$ for RS vs. RS+ACA and RS+AAC). (F) M2 cells were treated as described in (E). After 10 days, matrix mineralization in cultures was quantified using a ⁴⁵Ca incorporation assay as previously described. Results from a representative of three experiments are shown, reported as the mean of quadruplicate determinations \pm SD, normalized to protein concentration ($p < 0.01$ for RS vs. RS+ACA and RS+AAC).

[0099] Figure 9: A) is a bar graph depicting the effect of COX-1 inhibitor or oxysterol treatment on alkaline phosphatase activity in M2 cells; B) is a bar graph depicting the effect of COX-1 inhibitor or oxysterol treatment on calcium incorporation in M2 cells; C) is a radiogram of Northern blotting for osteoclastin or 18S rRNA in M2 cells exposed to COX-1 inhibitor or oxysterol treatment; D) is a bar graph depicting the relative densitometric units of osteoclastin mRNA in M2 cells exposed to COX-1 inhibitor or oxysterol treatment; E) is a bar graph depicting the effect of PLA₂ inhibitors or oxysterol treatment on alkaline phosphatase activity in M2 cells; and F) is a bar graph depicting the effect of PLA₂ inhibitors or oxysterol treatment on calcium incorporation in M2 cells.

[0100] In presence of fetal bovine serum, which corresponds to our experimental conditions, M2 cells in culture express both COX-1 and COX-2 mRNA at all stages of osteogenic differentiation. Consistent with the role of COX in osteogenesis, our studies showed that the COX-1 selective inhibitor SC-560, at 1-20 μ M, significantly inhibited the osteogenic effects of the 22R+20S and 22S+20S oxysterol combinations. SC-560 inhibited oxysterol-induced alkaline phosphatase activity (Fig. 9A), mineralization (Fig. 9B), and osteocalcin gene expression (Fig. 9C and 9D). Although less effective than SC-560, the non-selective COX inhibitors, Ibuprofen and Fluriprofin at non-toxic doses of 1-10 μ M, also significantly inhibited the osteogenic effects of 22R+20S oxysterol combination by 25-30%. In contrast, the selective COX-2 inhibitor, NS-398, at the highest non-toxic dose of 20 μ M had only negligible inhibitory effects. Furthermore, the osteogenic effects of the oxysterol combination on alkaline phosphatase activity (Fig. 9E) and mineralization (Fig. 9F) were also inhibited by the general phospholipase A2 (PLA2) inhibitor ACA and by the selective cytosolic PLA2 inhibitor, AACOCF3 (AAC). Activation of PLA2 releases arachidonic acid from cellular phospholipids and makes it available for further metabolism by COX enzymes into prostaglandins. Moreover, rescue experiments showed that the effects of the COX-1 and PLA2 inhibitors on oxysterol-induced alkaline phosphatase activity were reversed by the addition of 1 μ M PGE2 and 25 μ M arachidonic acid, respectively (data not shown). Consistent with previous reports of oxysterol-stimulated metabolism of arachidonic acid, the present results suggest that the osteogenic activity of the oxysterols in MSC are in part mediated by the activation of PLA2-induced arachidonic acid release, and its metabolism into osteogenic prostanoids by the COX pathway.

[0101] Example G: Role of ERK in mediating the responses of MSC to oxysterols. The extracellular signal-regulated kinase (ERK) pathway is another major signal transduction pathway previously associated with osteoblastic differentiation of osteoprogenitor cells. Sustained activation of ERKs mediates the osteogenic differentiation of human MSC52, and activation of ERKs in human osteoblastic cells results in upregulation of expression and

DNA binding activity of Cbfa1, the master regulator of osteogenic differentiation. Furthermore, ERK activation appears to be essential for growth, differentiation, and proper functioning of human osteoblastic cells.

[0102] (A) M2 cells at confluence were pretreated for four hours with RPMI containing 1% FBS, followed by treatment with control vehicle or 5 μ M 20S oxysterol for 1, 4, or 8 hours. Next total cell extracts were prepared and analyzed for levels of native or phosphorylated ERK (pERK) using specific antibodies as previously described. Data from a representative of four experiments are shown, each treatment shown in duplicate samples. (B) M2 cells at confluence were pretreated for 2 hours with control vehicle (C) or 20 μ M PD98059 (PD) in osteogenic medium as previously described. Next, a combination of 22R and 20S oxysterols (RS, 5 μ M each) were added to appropriate wells as indicated. After 10 days of incubation, matrix mineralization was quantified by the 45 Ca incorporation assay as previously described. Data from a representative of three experiments are reported as the mean \pm SD of quadruplicate determinations, normalized to protein concentration ($p < 0.01$ for RS vs. RS+PD). (C) M2 cells at confluence were pretreated for 2 hours with 20 μ M PD98059 (PD) in RPMI containing 5% FBS. Next, the cells were treated with control vehicle (C), 10 μ M troglitazone (Tro), or 10 μ M of 20S or 22S oxysterols, alone or in combination as indicated. After 10 days, adipocytes were visualized by oil Red O staining and quantified by light microscopy as previously described. Data from a representative of three experiments are reported as the mean \pm SD of quadruplicate determinations.

[0103] Figure 10: A) is a Western blot for pERK or ERK as expressed in M2 cells exposed to control or oxysterol treatment; B) is a bar graph depicting the effect of PD98059 or oxysterol treatment on calcium incorporation in M2 cells; C) is a bar graph depicting the number of adipocytes/field in each treatment group

[0104] Interestingly, the 20S oxysterol used alone or in combination with 22R oxysterol caused a sustained activation of ERK1 and ERK2 in M2 cells (Fig. 10A). Inhibition of ERK pathway by the inhibitor PD98059, inhibited oxysterol-

induced mineralization (Fig. 10B) but not alkaline phosphatase activity or osteocalcin mRNA expression in M2 cell cultures (data not shown). These results suggest that sustained activation of ERK is important in regulating certain specific, but not all, osteogenic effects of oxysterols.

[0105] Example H: The combination of 20S with either 22R or 22S also produced osteogenic effects in the mouse pluripotent embryonic fibroblast C3H10T1/2 cells, in murine calvarial pre-osteoblastic MC3T3-E1 cells, and in primary mouse MSC as assessed by stimulation of alkaline phosphatase activity and mineralization.

[0106] Other combinations of oxysterols that had stimulatory effects on osteogenic activity of marrow stromal cells were 22R+pregnanolone, 20S+pregnanolone, both at 5 μ M. Pregnanolone is an activator of another nuclear hormone receptor called PXR. However, the most effective combination oxysterols that consistently induced robust osteogenic activity of the marrow stromal cells including both induction of alkaline phosphatase and mineral formation was 22R- or 22S- in combination with 20S-hydrocholesterols.

[0107] Example I: Calvaria from 7 days old CD1 pups were surgically extracted (6 per treatment) and cultured for seven days in BGJ medium containing 2% fetal bovine serum in the presence or absence of 22R+20S (5 μ M each). Then, the calvaria were prepared and sectioned. Bone area (BAr) and tissue area (TAr) were determined using digital images of H&E stained parietal bones of the calvarial sections. 8-10 images were captured per calvaria, with each image advanced one field of view along the length of the calvaria until the entire section was imaged. The region of analysis extended from the lateral muscle attachments and included the entire calvarial section except for the saggital suture region, which was excluded. The cross sections of the parietal bones were taken approximately equidistant from the coronal and lambdoid sutures and in the same general region for each individual. Sections of this region were analyzed since they contained little to no suture tissue from the coronal and lambdoid areas. BAr was defined as pink-staining tissue that was not hyper-cellular and displayed a basic lamellar collagen

pattern. TAr was defined as the region of tissue between dorsal and ventral layers of lining cells and included BAr as well as undifferentiated cellular tissue and matrix. Separate determinations were made for void area, which was defined as the marrow spaces within the BAr, and was subtracted from BAr measurements prior to calculation of BAr%TAr. To account for differences in TAr between individuals, BAr is reported as a percent of the total TAr measured. Histomorphometric data (continuous variables) were assessed using a one way ANOVA followed by Student's t-test and Dunnett's test vs. control. A p value of 0.05 was used to delineate significant differences between groups. Results are expressed as mean \pm SD.

[0108] Results. Figure 11 is a table depicting the effect of 22R + 20S oxysterol combination on mouse calvaria bone formation. A 20% increase in bone formation in the calvaria treated with the combination oxysterols was observed compared to those treated with control vehicle, further supporting the osteogenic activity of the combination oxysterols, *ex vivo*. Figure 12 are representative sections of calvaria treated with a vehicle (A) or 22R + 20S oxysterol.

WE CLAIM:

1. A method of inducing osteoblastic differentiation of mammalian mesenchymal stem cells including treating mammalian mesenchymal cells with at least one oxysterol.

2. The method of claim 1, wherein the at least one oxysterol is selected from the group comprising 20S-hydroxycholesterol, 22S-hydroxycholesterol, 22R-hydroxycholesterol, 25-hydroxycholesterol, or pregnanolone, or an active portion of any one of 20S-hydroxycholesterol, 22S-hydroxycholesterol, 22R-hydroxycholesterol, 25-hydroxycholesterol, or pregnanolone.

3. The method of claim 1, wherein the at least one oxysterol is a combination of oxysterols selected from the group comprising 20S-hydroxycholesterol and 22R-hydroxycholesterol, or 20S-hydroxycholesterol and 22S-hydroxycholesterol.

4. The method of claim 1, further comprising treating the mammalian mesenchymal cells with at least one secondary agent selected from the group comprising parathyroid hormone, sodium fluoride, insulin-like growth factor I, insulin-like growth factor II or transforming growth factor beta.

5. The method of claim 1, further comprising treating the mammalian mesenchymal cells with at least one secondary agent selected from the group comprising cytochrome P450 inhibitors, phospholipase activators, arachadonic acid, COX enzyme activators, osteogenic prostanoids or ERK activators.

6. A method of stimulating mammalian cells to express a level of a biological marker of osteoblastic differentiation which is greater than the level of a biological marker in untreated cells, comprising exposing a mammalian cell to a selected dose of at least one oxysterol.

7. The method of claim 6, wherein the at least one oxysterol is selected from the group comprising 20S-hydroxycholesterol, 22S-hydroxycholesterol, 22R-hydroxycholesterol, 25-hydroxycholesterol, or pregnanolone, or an active portion of any one of 20S-hydroxycholesterol, 22S-

hydroxycholesterol, 22R-hydroxycholesterol, 25-hydroxycholesterol, or pregnanolone.

8. The method of claim 6, wherein the at least one oxysterol is a combination of oxysterols selected from the group comprising 20S-hydroxycholesterol and 22R-hydroxycholesterol, or 20S-hydroxycholesterol and 22S-hydroxycholesterol.

9. The method of claim 6, further comprising treating the mammalian mesenchymal cells with at least one secondary agent selected from the group comprising parathyroid hormone, sodium fluoride, insulin-like growth factor I, insulin-like growth factor II or transforming growth factor beta.

10. The method of claim 6, further comprising treating the mammalian mesenchymal cells with at least one secondary agent selected from the group comprising cytochrome P450 inhibitors, phospholipase activators, arachadonic acid, COX enzyme activators, osteogenic prostanoids or ERK activators.

11. The method of claim 6 wherein the biological marker is an increase in at least one of alkaline phosphatase activity, calcium incorporation, mineralization or expression of osteocalcin mRNA.

12. The method of claim 6 wherein the mammalian cells are selected from the group comprising mesenchymal stem cells, osteoprogenitor cells or calvarial organ cultures.

13. A method of inhibiting adipocyte differentiation of mammalian mesenchymal stem cells including treating mammalian mesenchymal cells with at least one oxysterol.

14. The method of claim 13, wherein the at least one oxysterol is selected from the group comprising 20S-hydroxycholesterol, 22S-hydroxycholesterol, 22R-hydroxycholesterol, 25-hydroxycholesterol, or pregnanolone, or an active portion of any one of 20S-hydroxycholesterol, 22S-hydroxycholesterol, 22R-hydroxycholesterol, 25-hydroxycholesterol, or pregnanolone.

15. A method of treating a patient to increase the differentiation of marrow stromal cells into osteoblasts, comprising administering at least one oxysterol at a therapeutically effective dose in an effective dosage form at a selected interval to increase the number of osteoblasts present in bone tissue.

16. The method of claim 15, wherein the at least one oxysterol is selected from the group comprising 20S-hydroxycholesterol, 22S-hydroxycholesterol, 22R-hydroxycholesterol, 25-hydroxycholesterol, or pregnanolone, or an active portion of any one of 20S-hydroxycholesterol, 22S-hydroxycholesterol, 22R-hydroxycholesterol, 25-hydroxycholesterol, or pregnanolone.

17. The method of claim 15, wherein the at least one oxysterol is a combination of oxysterols selected from the group comprising 20S-hydroxycholesterol and 22R-hydroxycholesterol, or 20S-hydroxycholesterol and 22S-hydroxycholesterol.

18. The method of claim 15, further comprising treating the patient with at least one secondary agent selected from the group comprising parathyroid hormone, sodium fluoride, insulin-like growth factor I, insulin-like growth factor II or transforming growth factor beta.

19. A method of treating a patient to induce bone formation comprising administering at least one oxysterol at a therapeutically effective dose in an effective dosage form at a selected interval to increase bone mass.

20. The method of claim 19, wherein the at least one oxysterol is selected from the group comprising 20S-hydroxycholesterol, 22S-hydroxycholesterol, 22R-hydroxycholesterol, 25-hydroxycholesterol, or pregnanolone, or an active portion of any one of 20S-hydroxycholesterol, 22S-hydroxycholesterol, 22R-hydroxycholesterol, 25-hydroxycholesterol, or pregnanolone.

21. The method of claim 19, wherein the at least one oxysterol is a combination of oxysterols selected from the group comprising 20S-

hydroxycholesterol and 22R-hydroxycholesterol, or 20S-hydroxycholesterol and 22S-hydroxycholesterol.

22. The method of claim 19, further comprising treating the patient with at least one secondary agent selected from the group comprising parathyroid hormone, sodium fluoride, insulin-like growth factor I, insulin-like growth factor II or transforming growth factor beta, at a therapeutically effective dose.

23. A method of claim 19, further comprising treating a patient with at least one secondary agent selected from the group comprising bisphosphonates, selective estrogen receptor modulators, calcitonin, or vitamin D and calcium, at a therapeutically effective dose.

24. A method of treating a patient exhibiting clinical symptoms of osteoporosis comprising administering at least one oxysterol at a therapeutically effective dose in an effective dosage form at a selected interval to ameliorate the symptoms of the osteoporosis.

25. The method of claim 24, wherein the at least one oxysterol is selected from the group comprising 20S-hydroxycholesterol, 22S-hydroxycholesterol, 22R-hydroxycholesterol, 25-hydroxycholesterol, or pregnanolone, or an active portion of any one of 20S-hydroxycholesterol, 22S-hydroxycholesterol, 22R-hydroxycholesterol, 25-hydroxycholesterol, or pregnanolone.

26. The method of claim 24, wherein the at least one oxysterol is a combination of oxysterols selected from the group comprising 20S-hydroxycholesterol and 22R-hydroxycholesterol, or 20S-hydroxycholesterol and 22S-hydroxycholesterol.

27. The method of claim 25, further comprising treating the patient with at least one secondary agent selected from the group comprising parathyroid hormone, sodium fluoride, insulin-like growth factor I, insulin-like growth factor II or transforming growth factor beta, at a therapeutically effective dose.

28. A method of claim 25, further comprising treating a patient with at least one secondary agent selected from the group comprising bisphosphonates, selective estrogen receptor modulators, calcitonin, or vitamin D and calcium, at a therapeutically effective dose.

29. A method of treating a patient to induce bone formation comprising:

harvesting mammalian mesenchymal stem cells;

treating the mammalian mesenchymal cells with at least one agent, wherein the at least one agent induces the mesenchymal stem cells to express at least one cellular marker of osteoblastic differentiation;

administering the differentiated cells to the patient.

30. The method of claim 29, wherein the at least one oxysterol is selected from the group comprising 20S-hydroxycholesterol, 22S-hydroxycholesterol, 22R-hydroxycholesterol, 25-hydroxycholesterol, or pregnanolone, or an active portion of any one of 20S-hydroxycholesterol, 22S-hydroxycholesterol, 22R-hydroxycholesterol, 25-hydroxycholesterol, or pregnanolone.

31. The method of claim 29, wherein the at least one oxysterol is a combination of oxysterols selected from the group comprising 20S-hydroxycholesterol and 22R-hydroxycholesterol, or 20S-hydroxycholesterol and 22S-hydroxycholesterol.

32. The method of claim 29 further comprising administering at least one oxysterol at a therapeutically effective dose in an effective dosage form at a selected interval.

33. The method of claim 29, further comprising treating the patient with at least one secondary agent selected from the group comprising parathyroid hormone, sodium fluoride, insulin-like growth factor I, insulin-like growth factor II or transforming growth factor beta, at a therapeutically effective dose.

34. The method of claim 29, further comprising treating a patient with at least one secondary agent selected from the group comprising bisphosphonates, selective estrogen receptor modulators, calcitonin, or vitamin D and calcium, at a therapeutically effective dose.

35. The method of claim 29, further comprising administering the differentiated cells to the patient by systemic injection.

36. The method of claim 29, further comprising administering the differentiated cells to the patient by application of the cells to a selected site where bone formation is desired.

37. An implant for use in the human body comprising, a substrate having a surface, wherein at least the surface of the implant includes at least one oxysterol in an amount sufficient to induce bone formation in the surrounding bone tissue.

38. The implant of claim 37, wherein the substrate is formed into the shape of a pin, screw, plate, or prosthetic joint.

39. An implant for use in the human body comprising, a substrate having a surface, wherein at least the surface of the implant includes mammalian cells capable of osteoblastic differentiation.

40. An implant for use in the human body comprising, a substrate having a surface, wherein at least the surface of the implant includes osteoblastic mammalian cells.

41. A medicament for use in the treatment of bone disorders comprising a therapeutically effective dosage of at least one oxysterol selected from the group comprising 20S-hydroxycholesterol, 22S-hydroxycholesterol, 22R-hydroxycholesterol, 25-hydroxycholesterol, or pregnanolone, or an active portion of any one of 20S-hydroxycholesterol, 22S-hydroxycholesterol, 22R-hydroxycholesterol, 25-hydroxycholesterol, or pregnanolone.

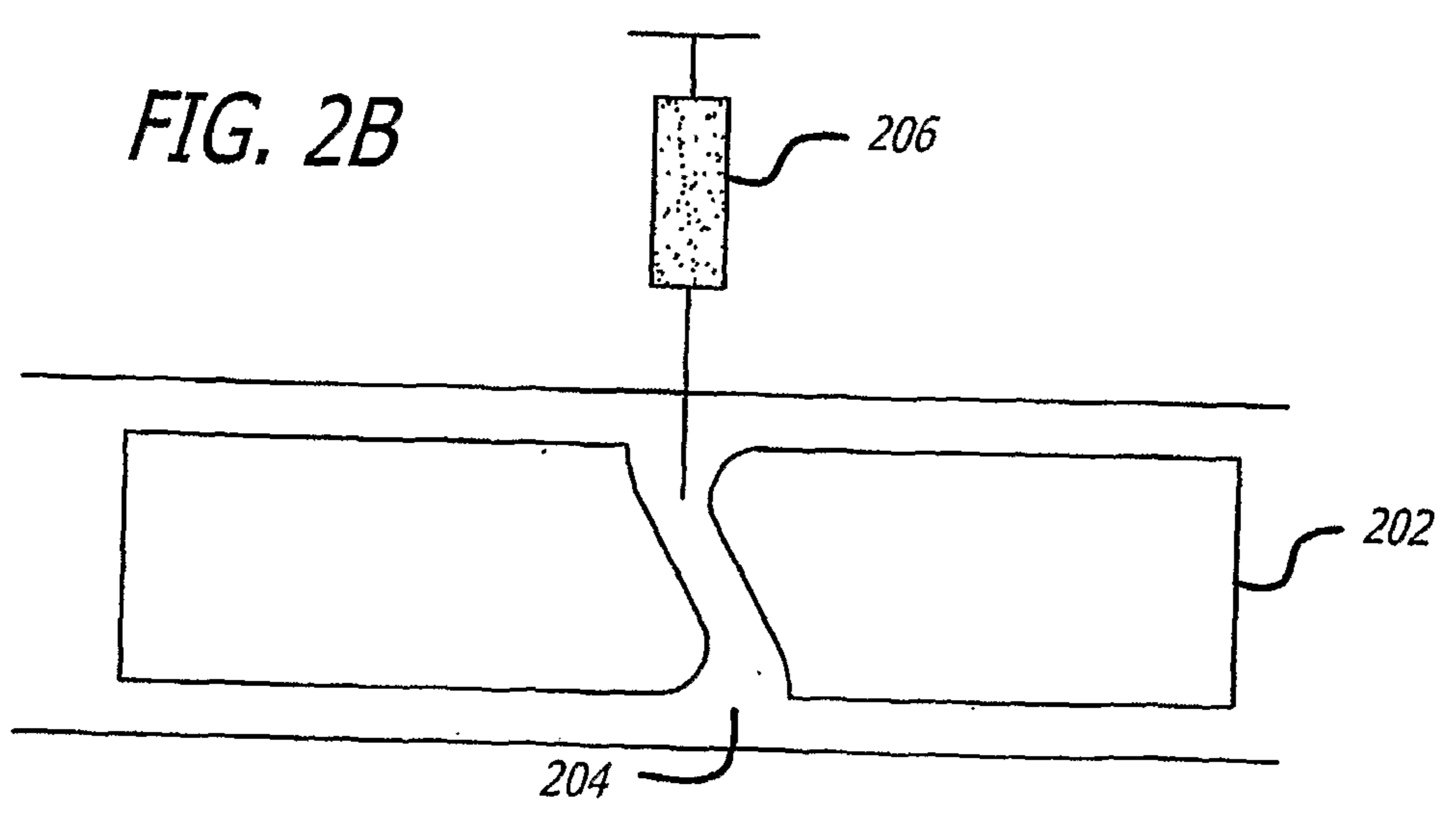
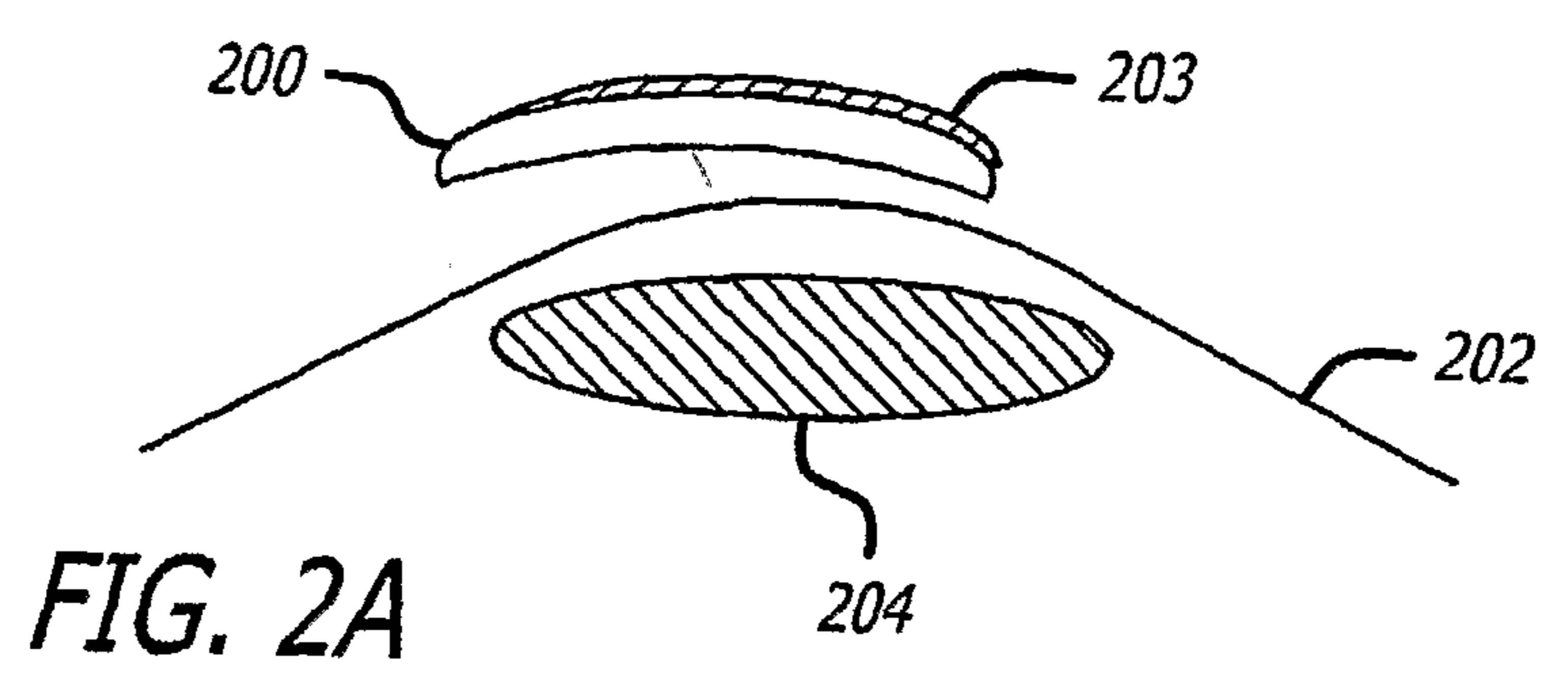
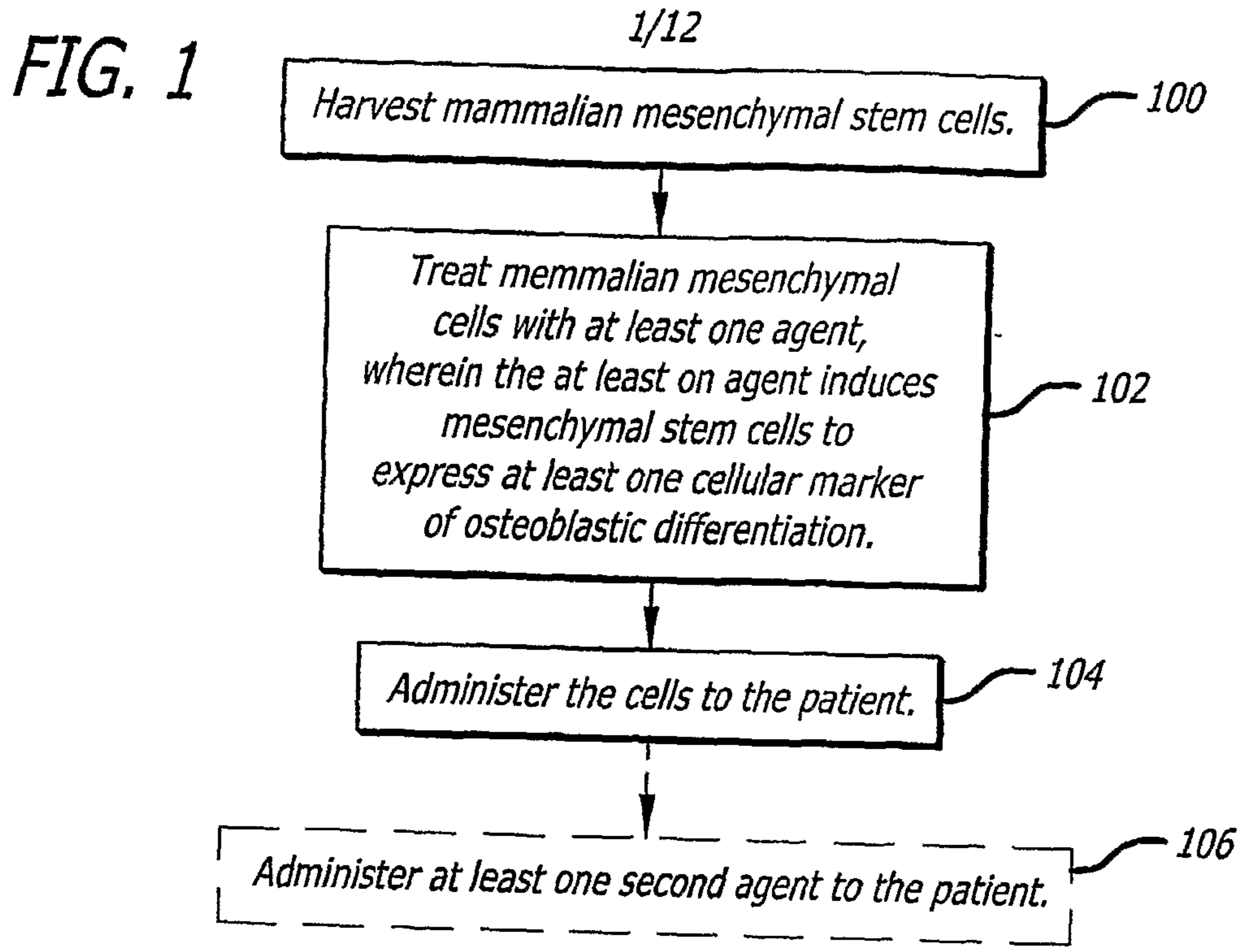

2/12

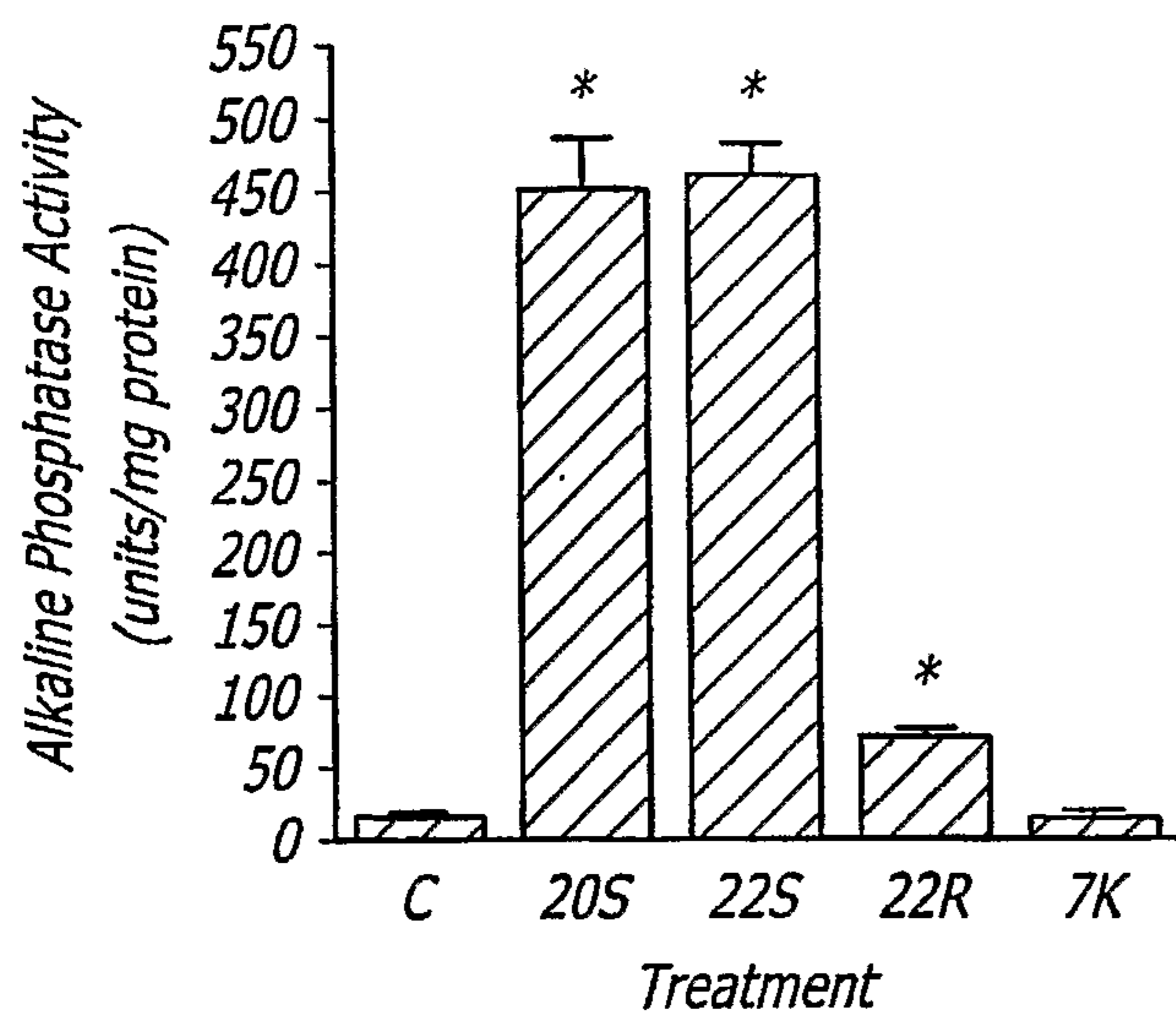

FIG. 3A

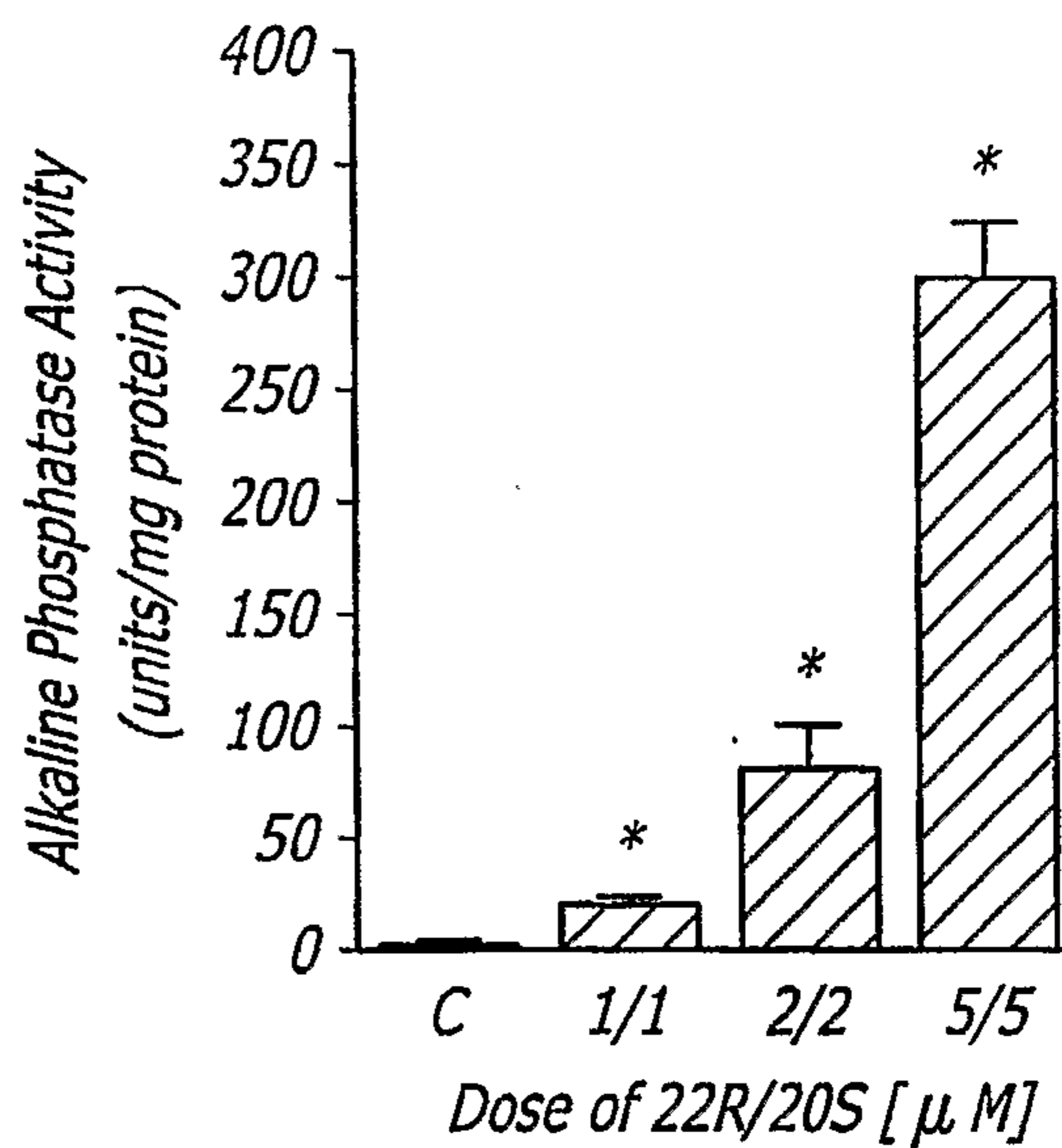

FIG. 3B

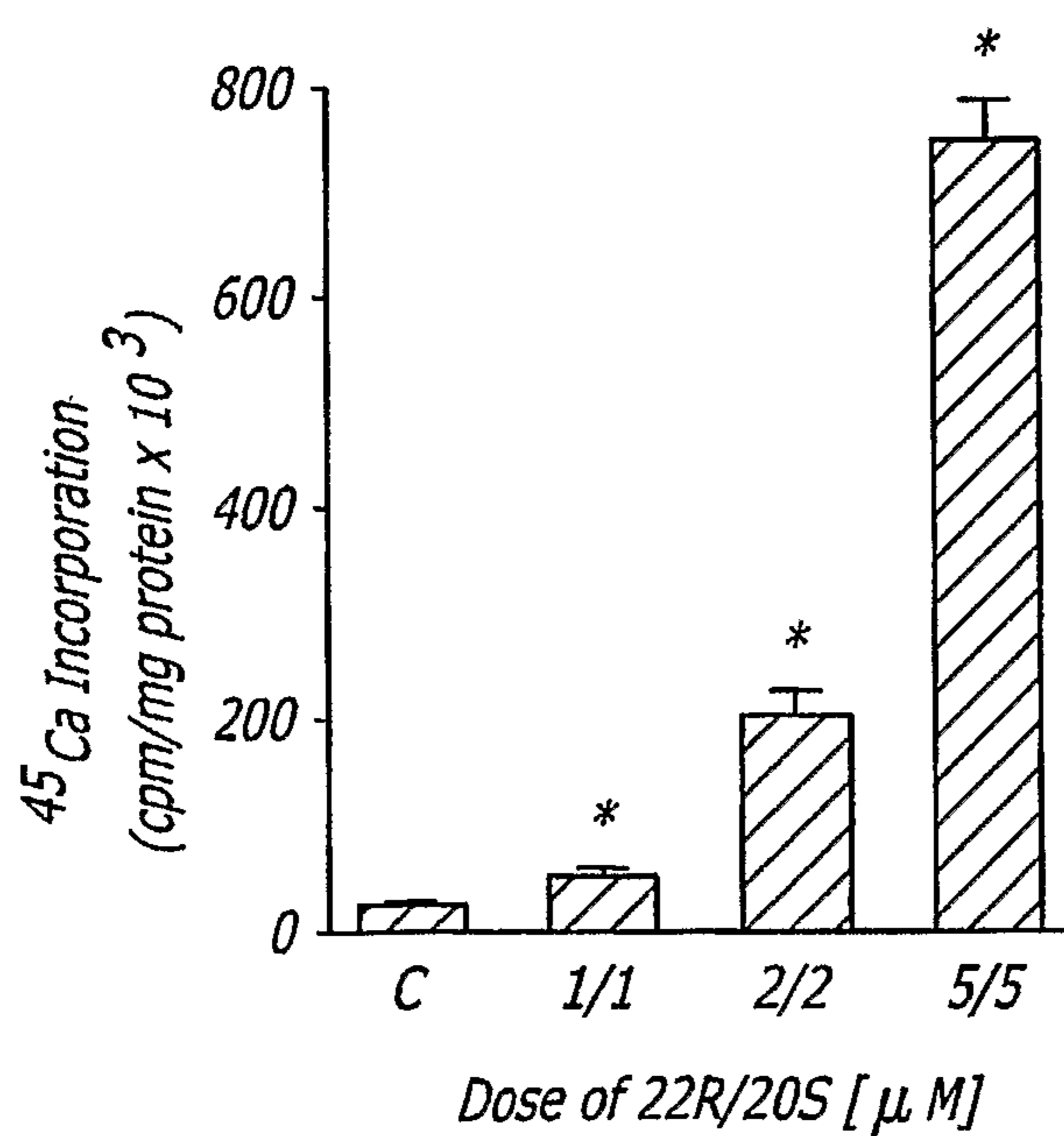

FIG. 3D

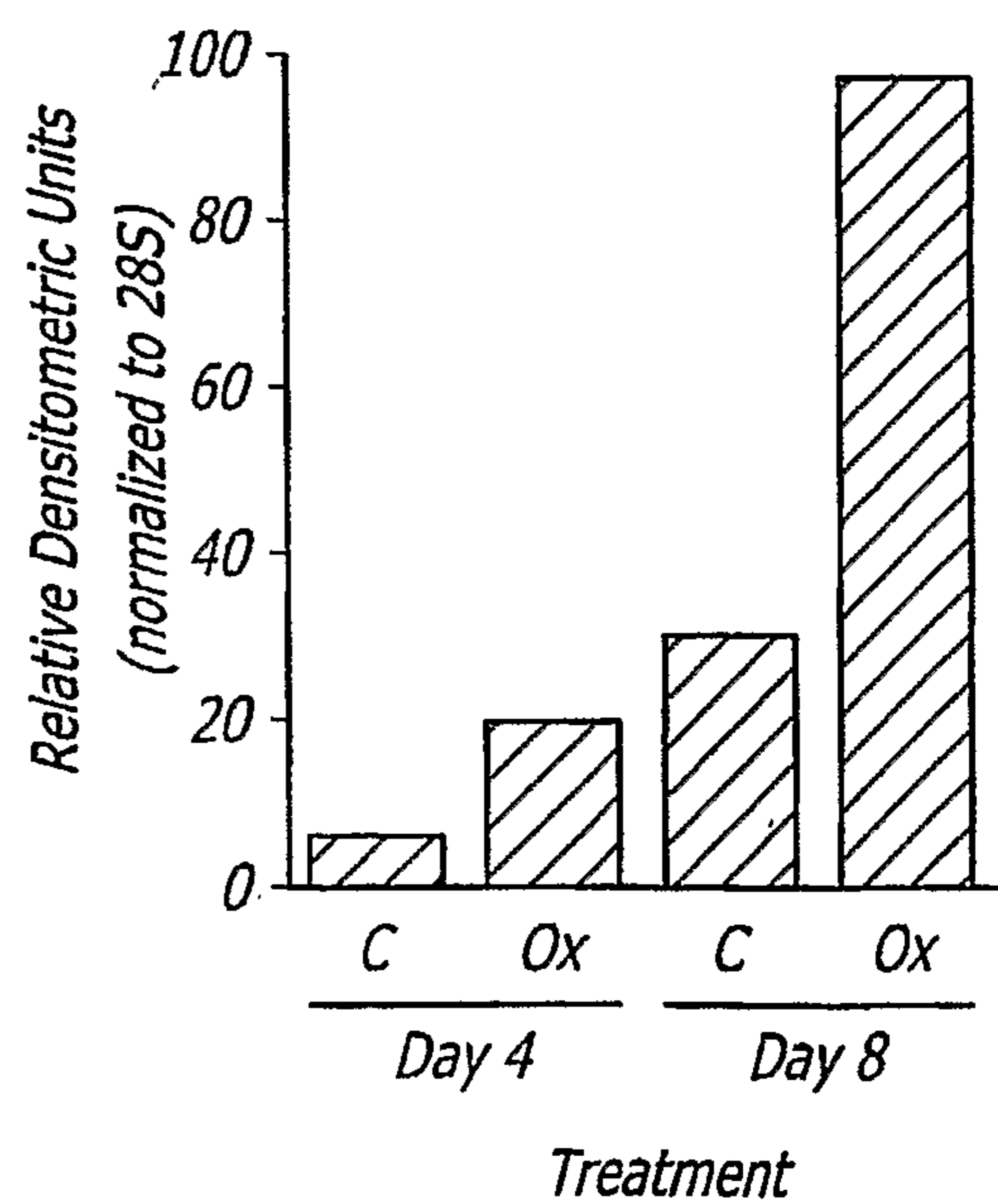

FIG. 3F

3/12

FIG. 3C

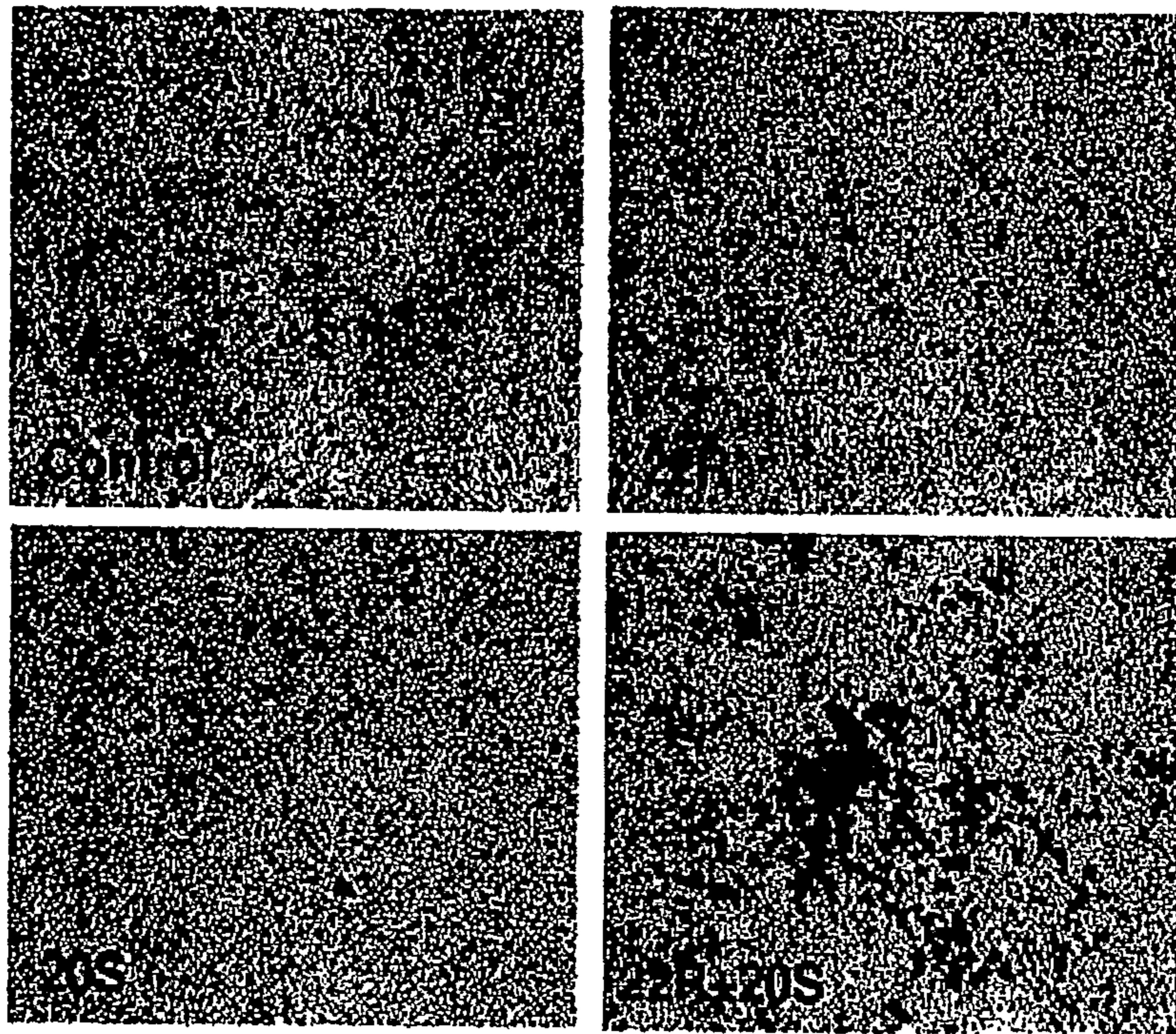
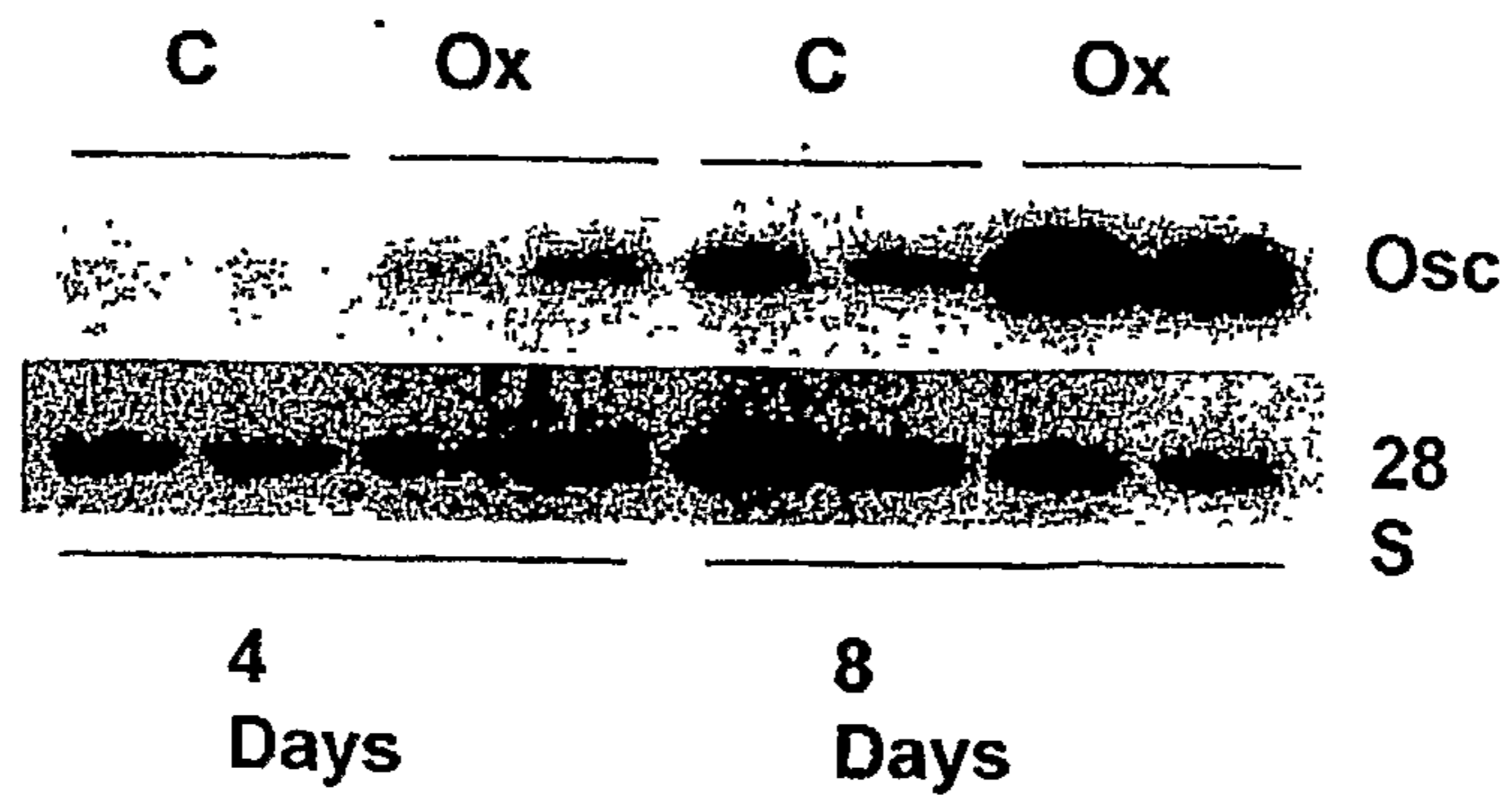

FIG. 3E



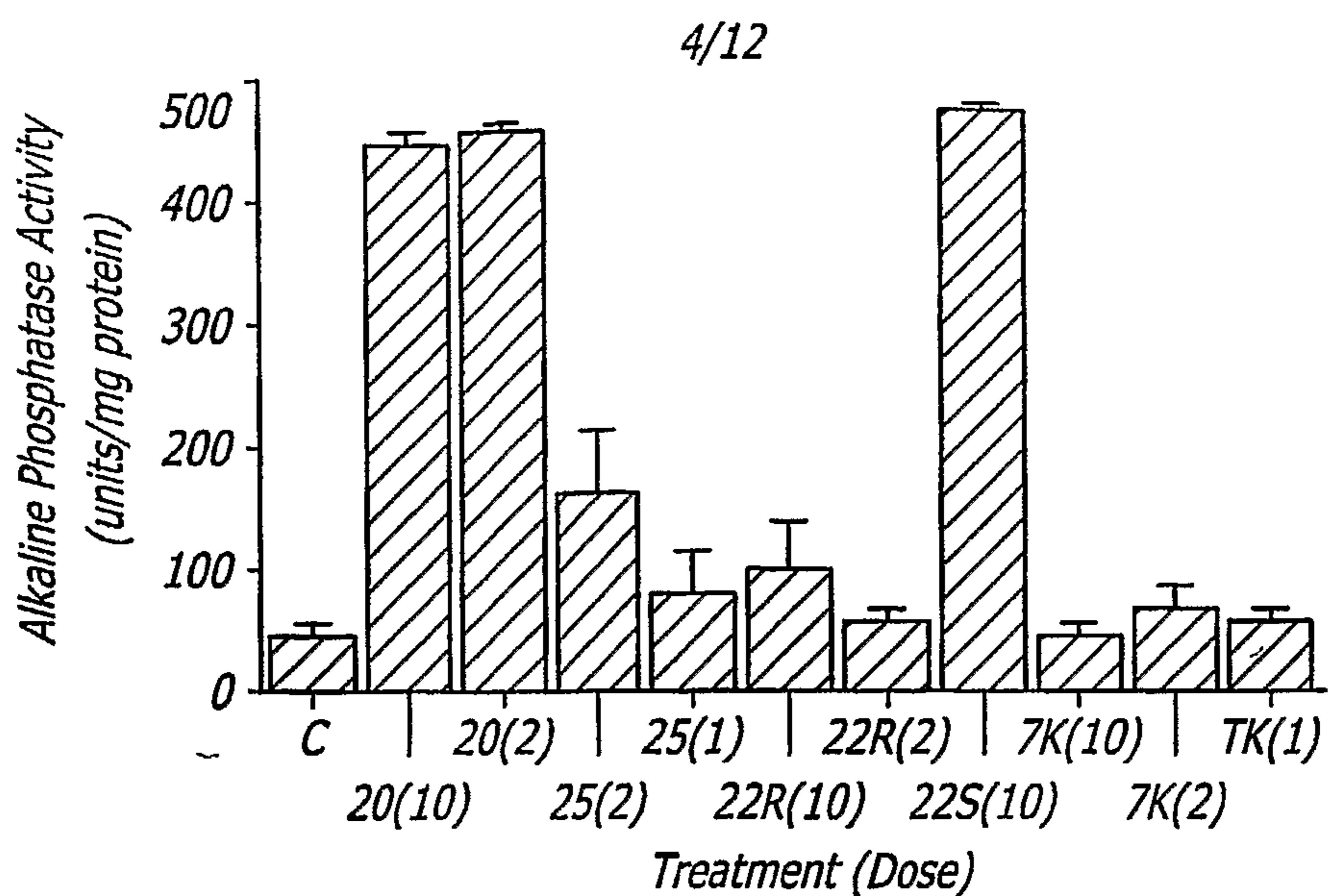

FIG. 4A

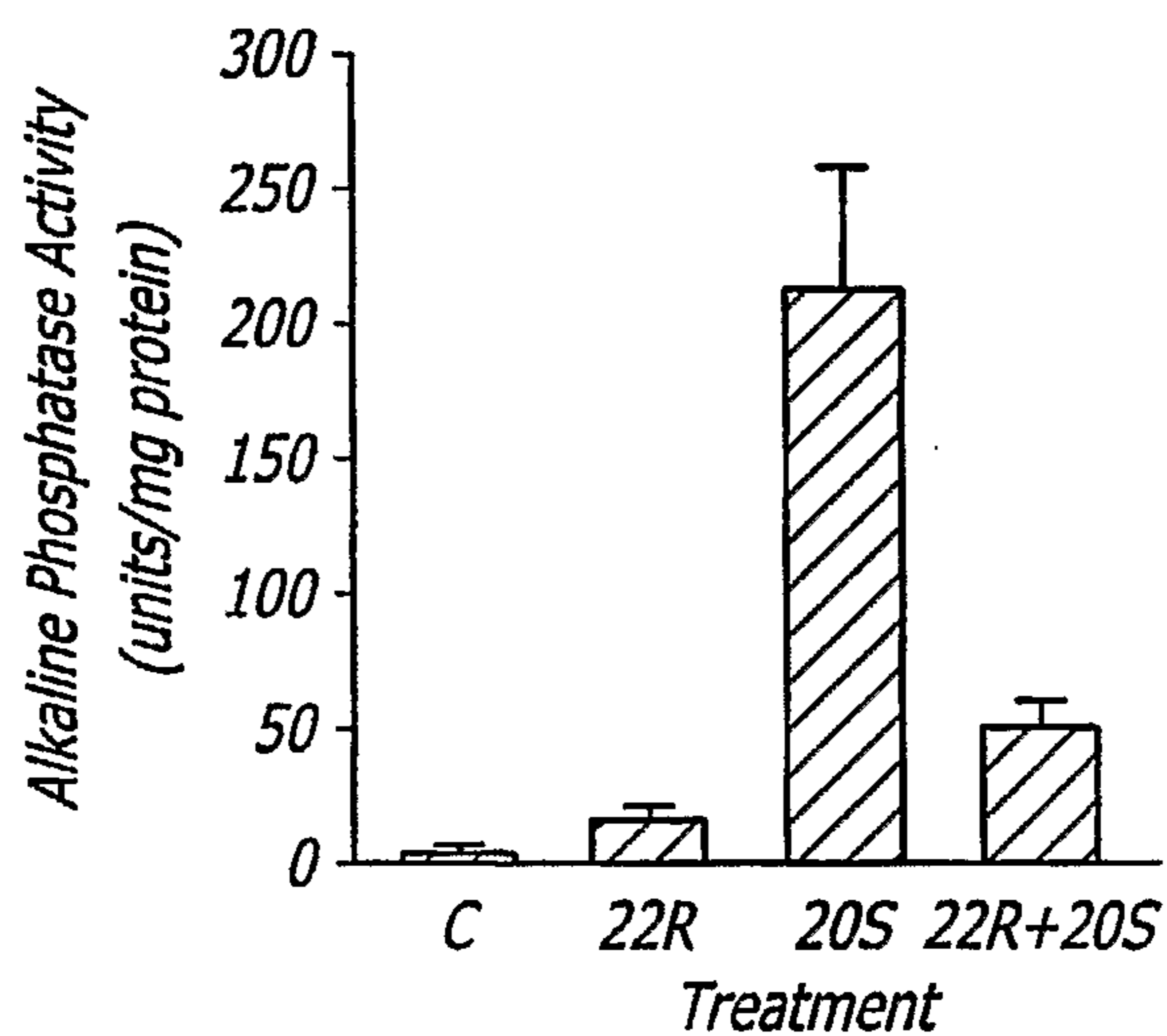

FIG. 4B

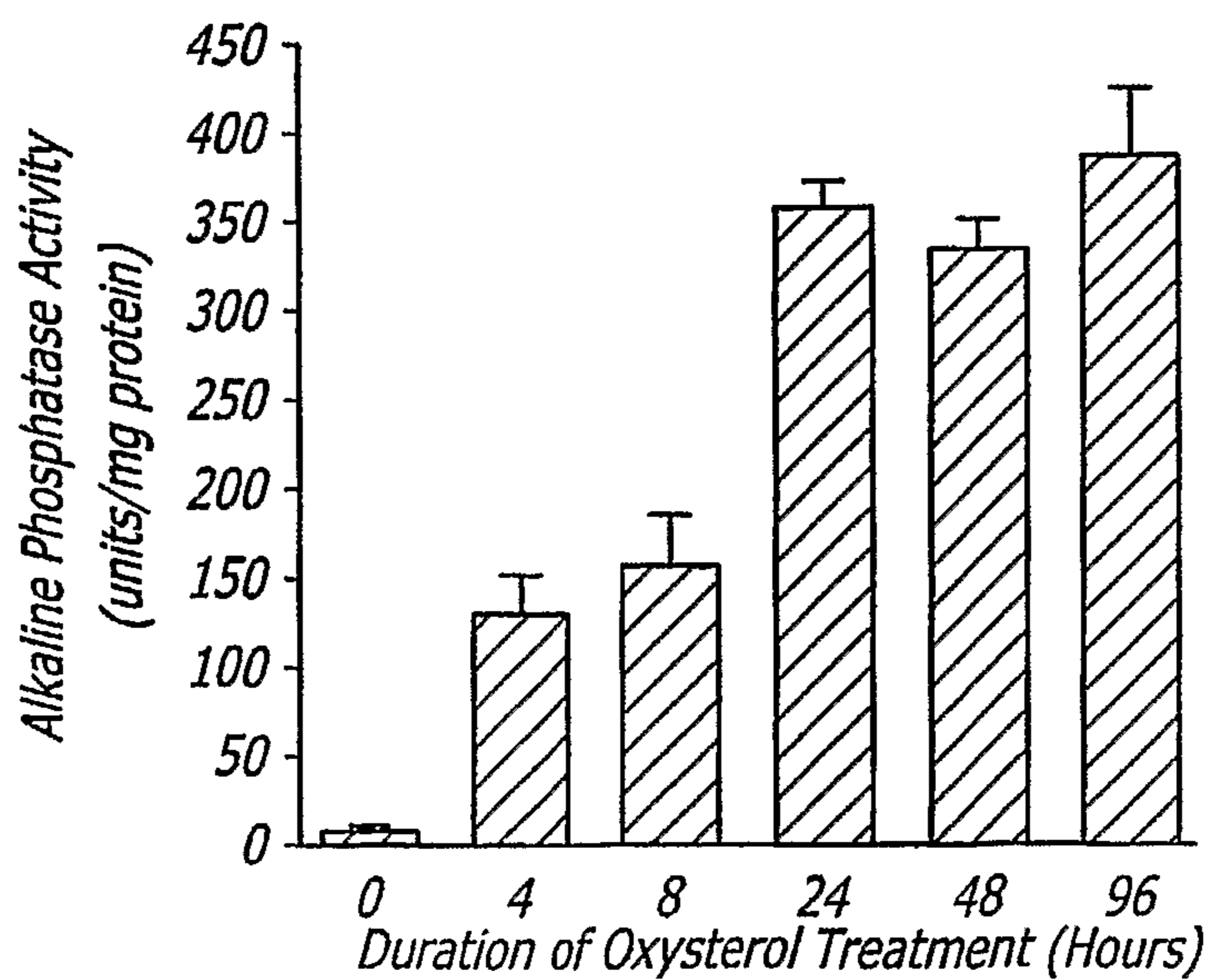

FIG. 4C

5/12

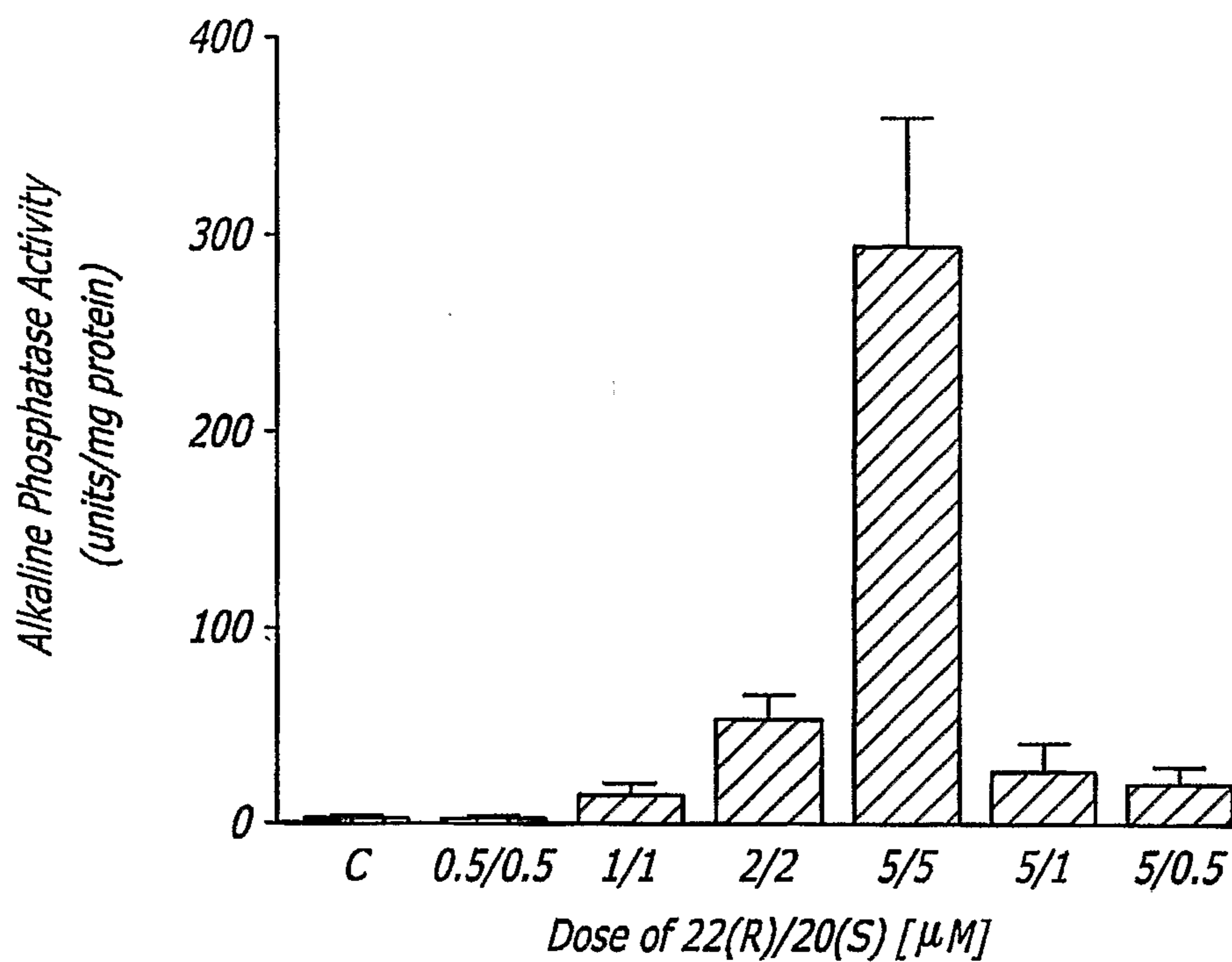

FIG. 4D

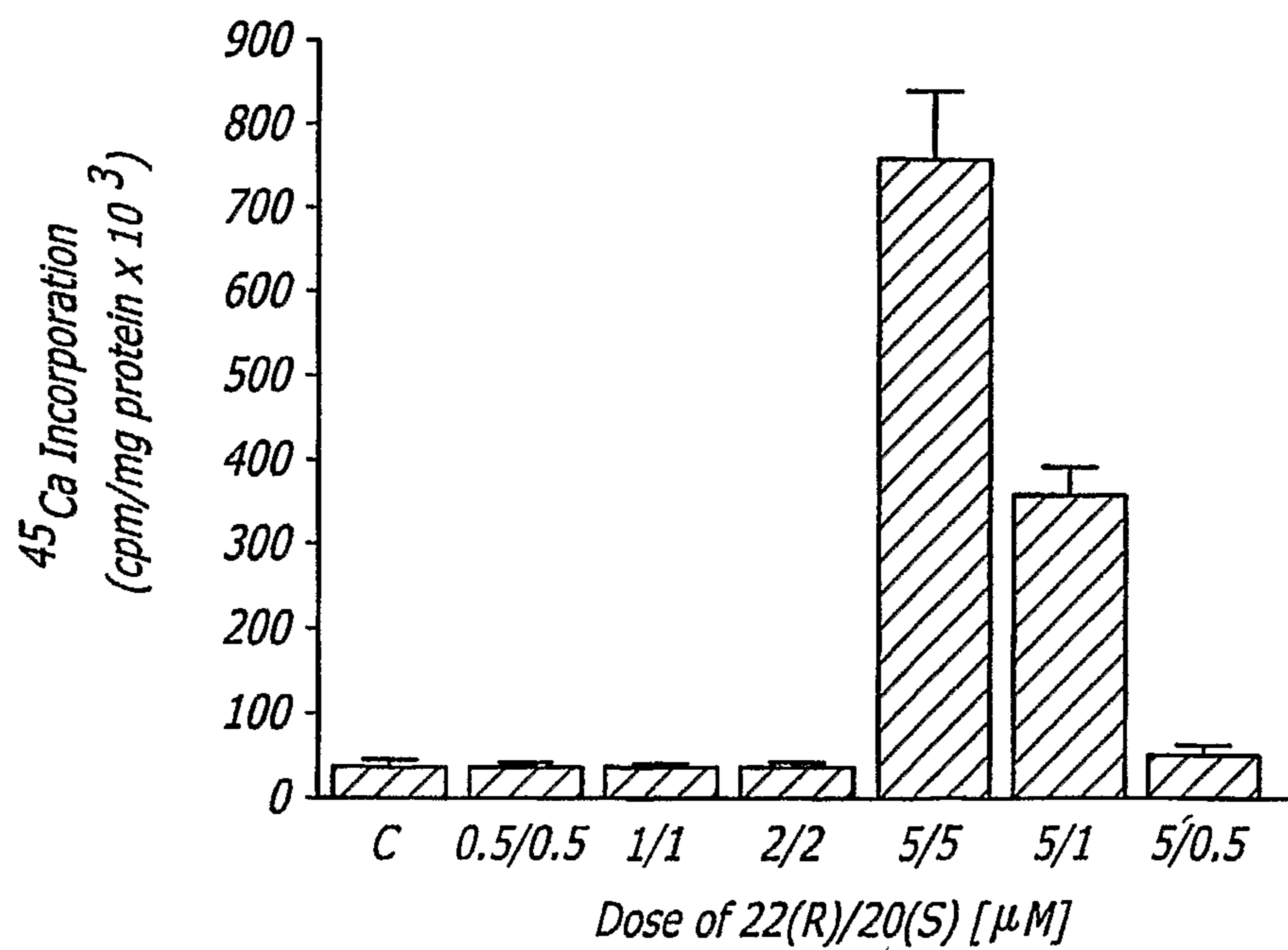

FIG. 4E

6/12

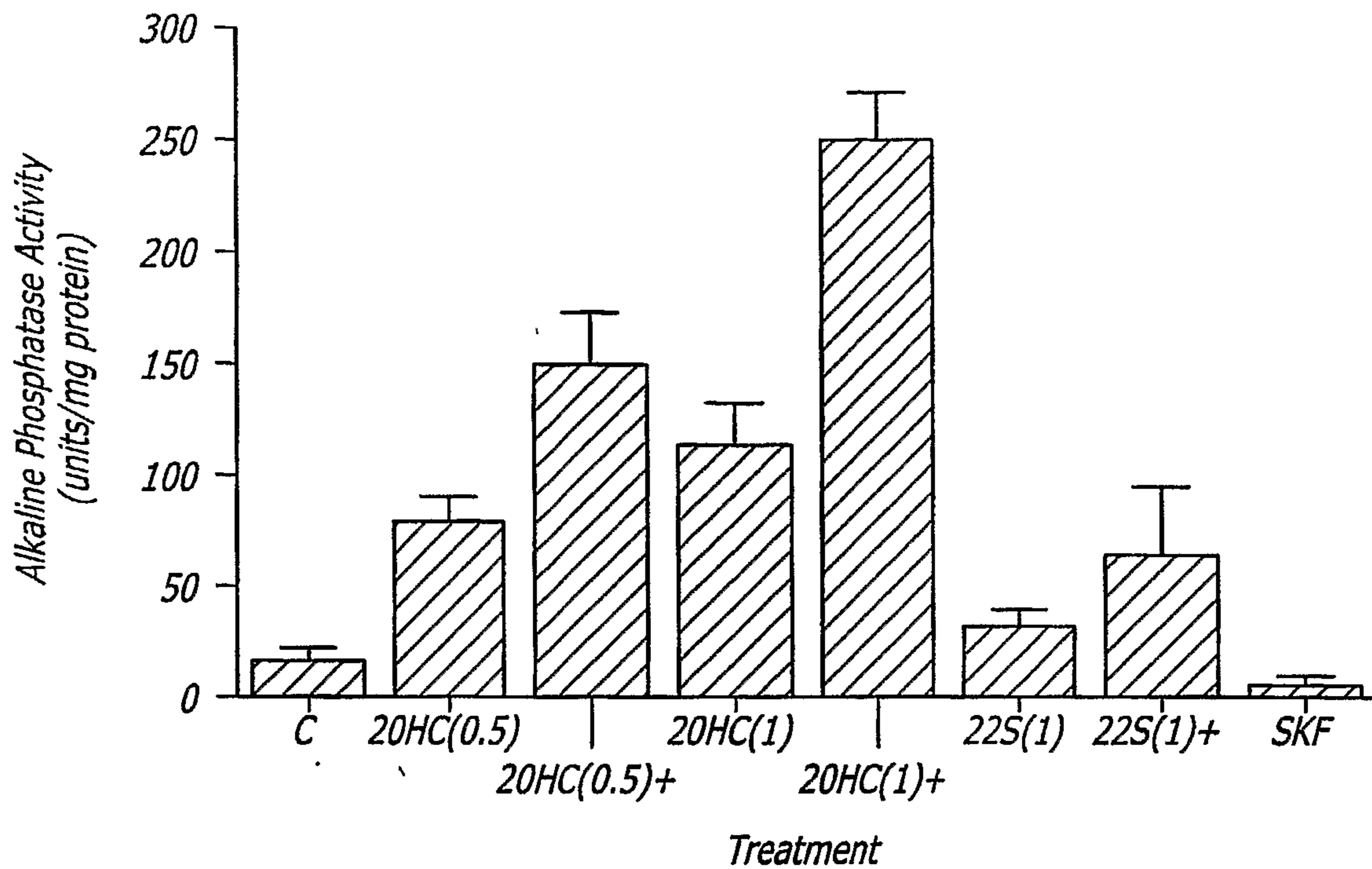

FIG. 5A

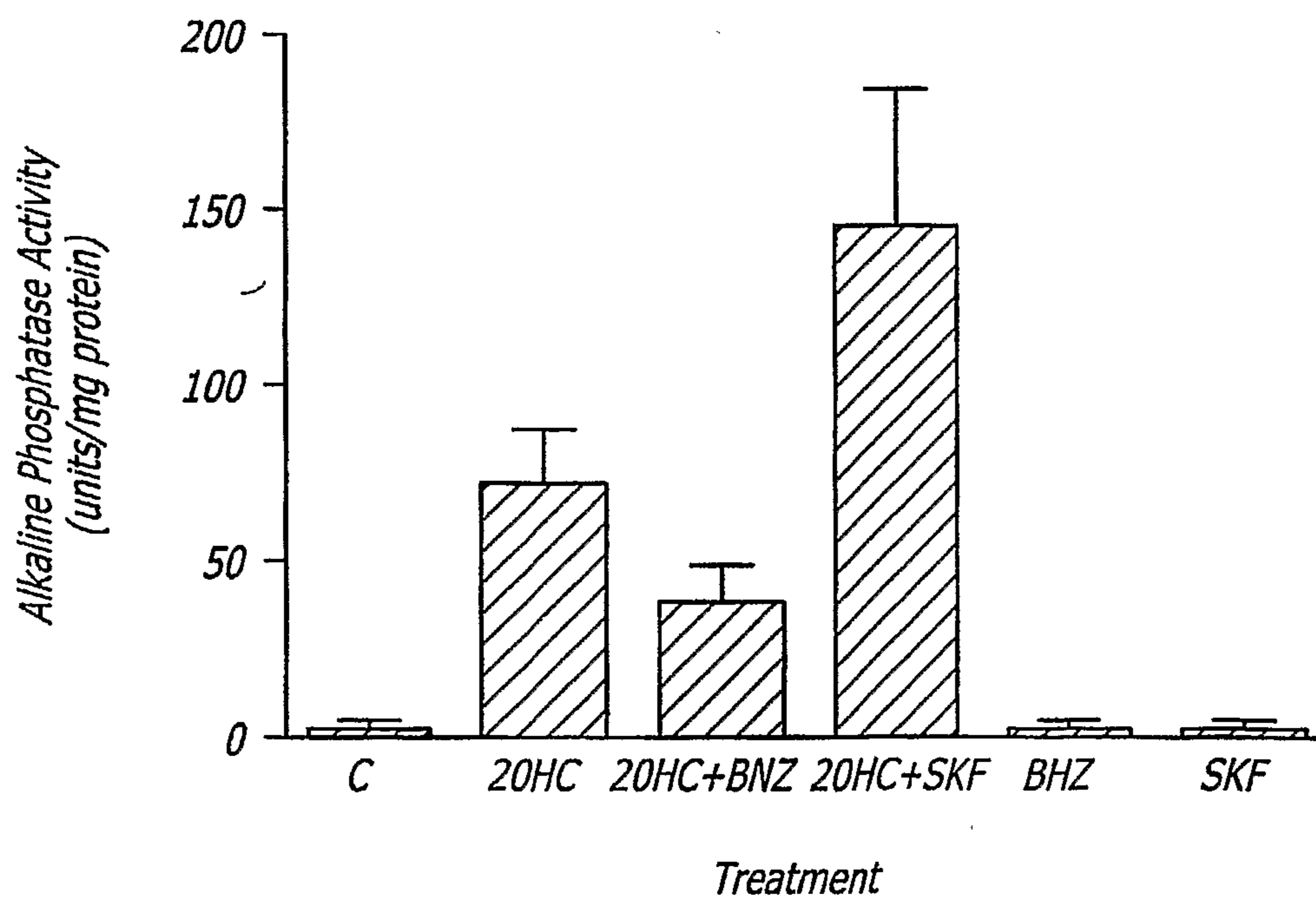

FIG. 5B

7/12

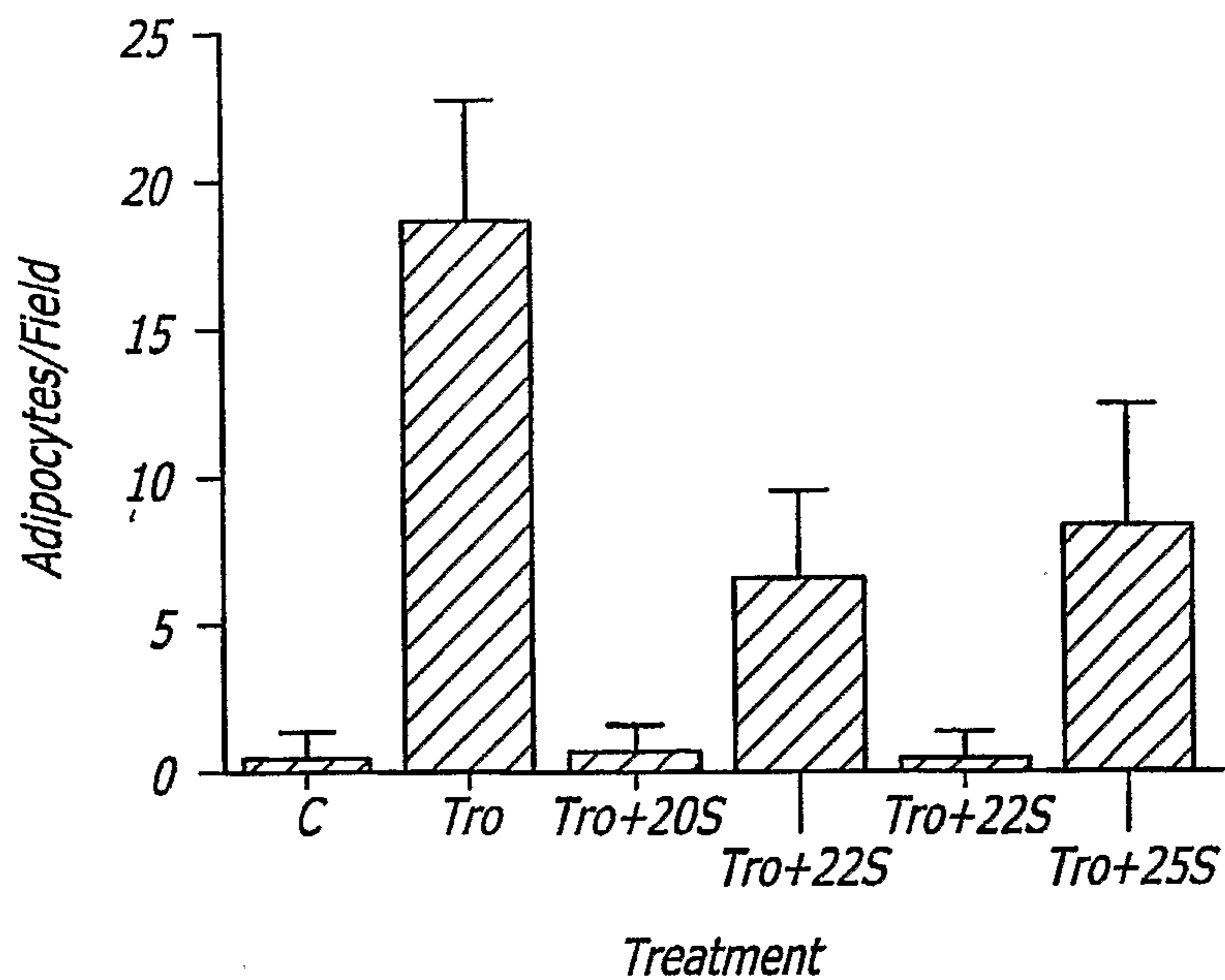

FIG. 6

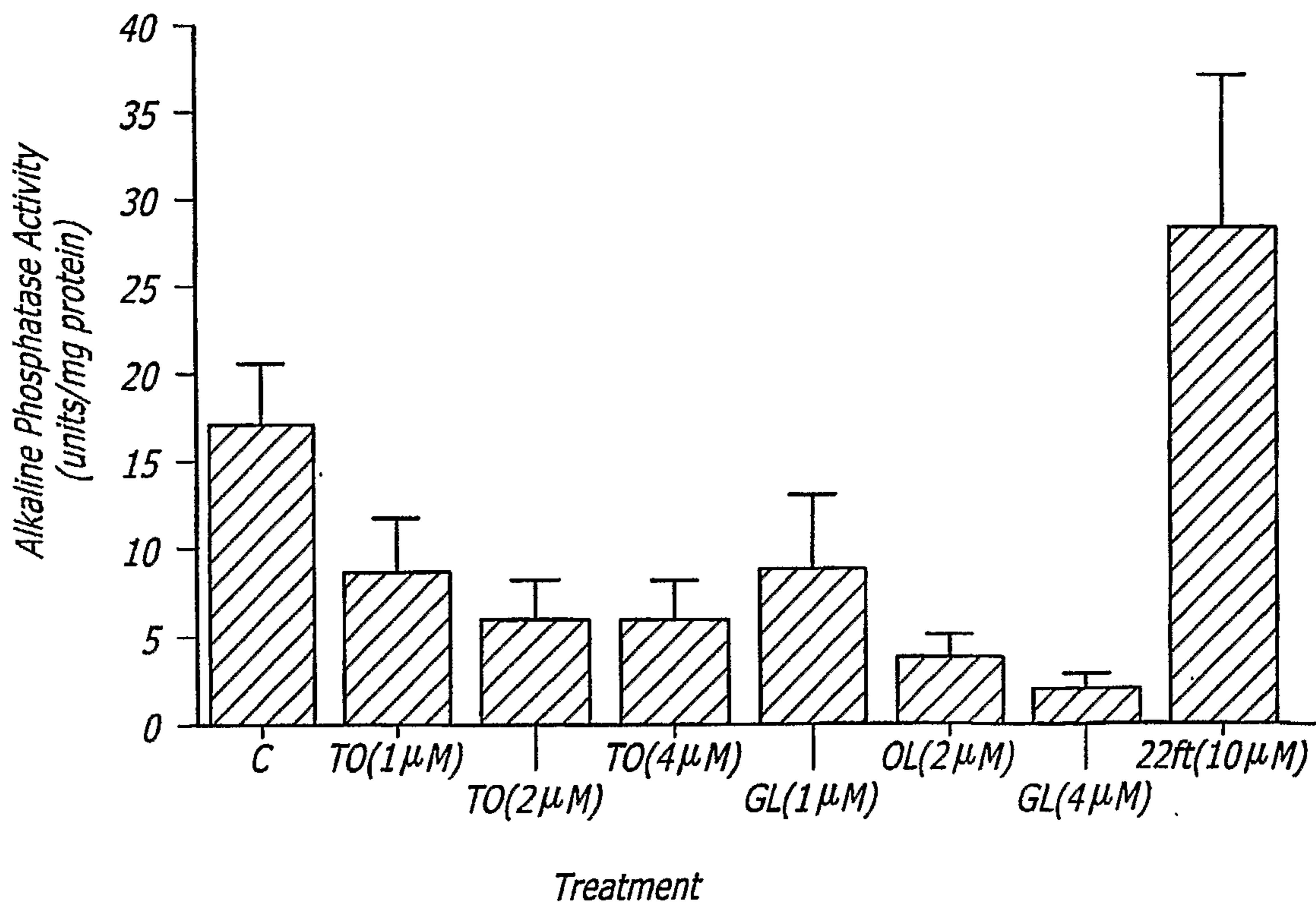

FIG. 8

8/12

FIG. 7A

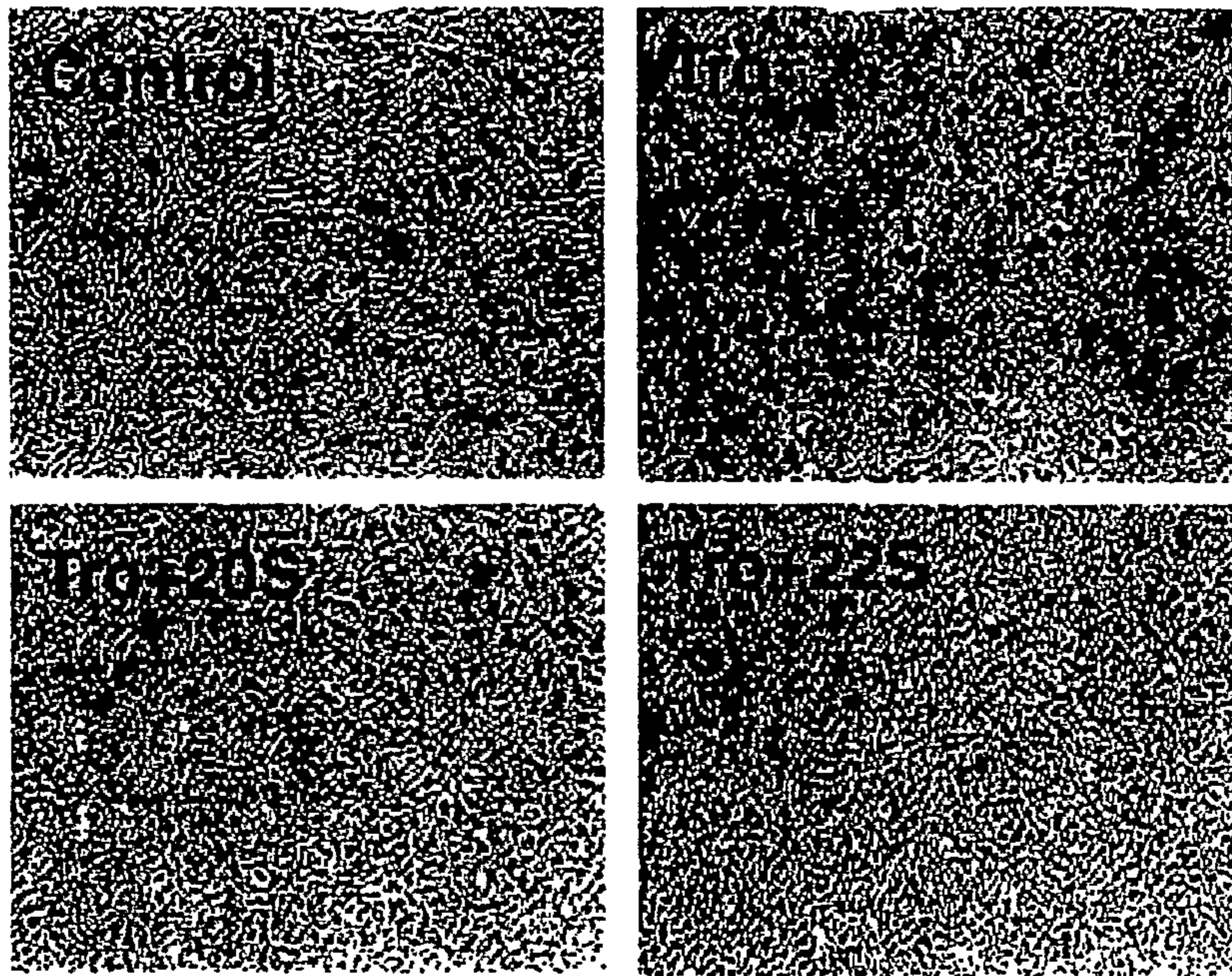

FIG. 7C

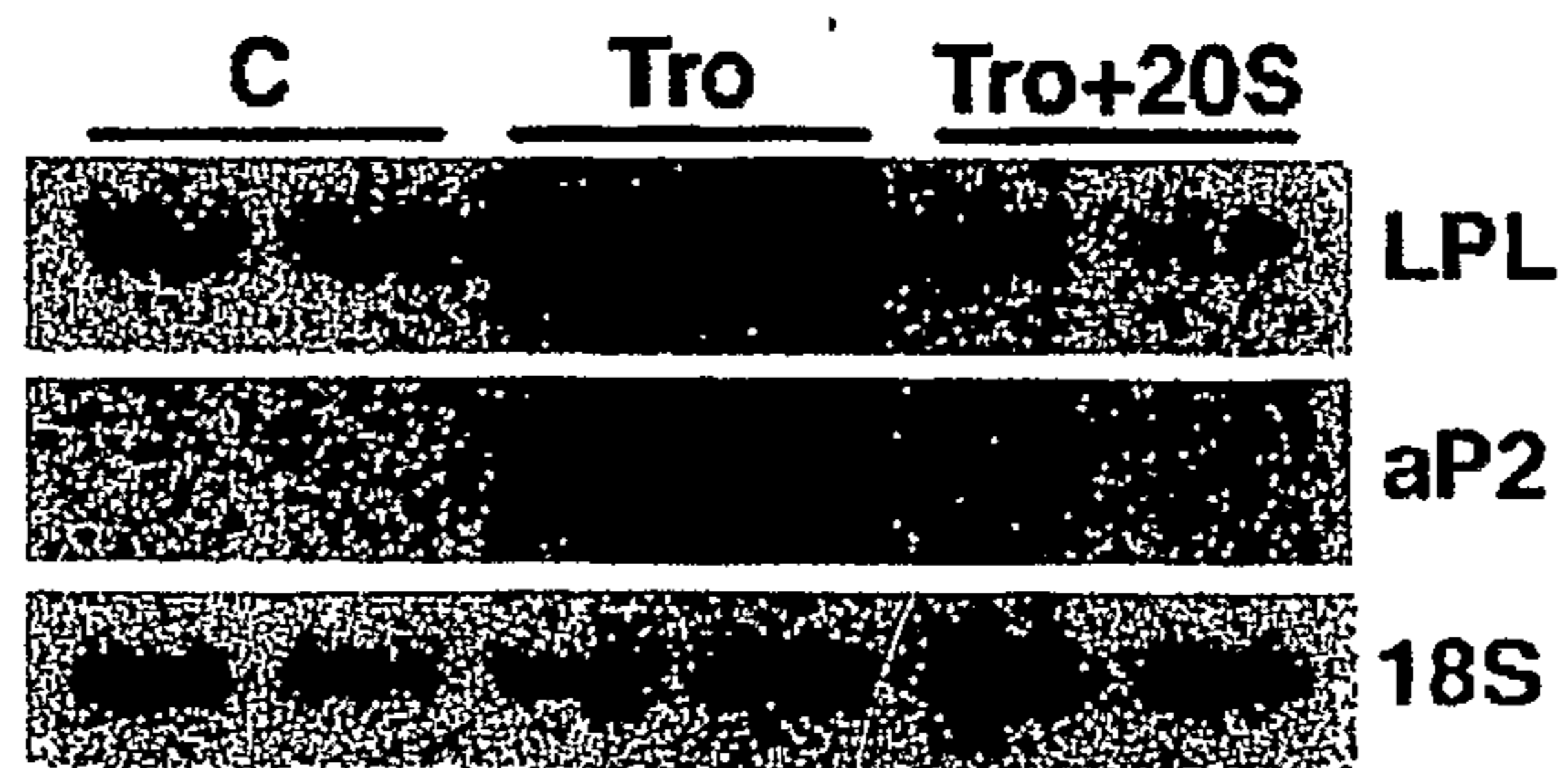
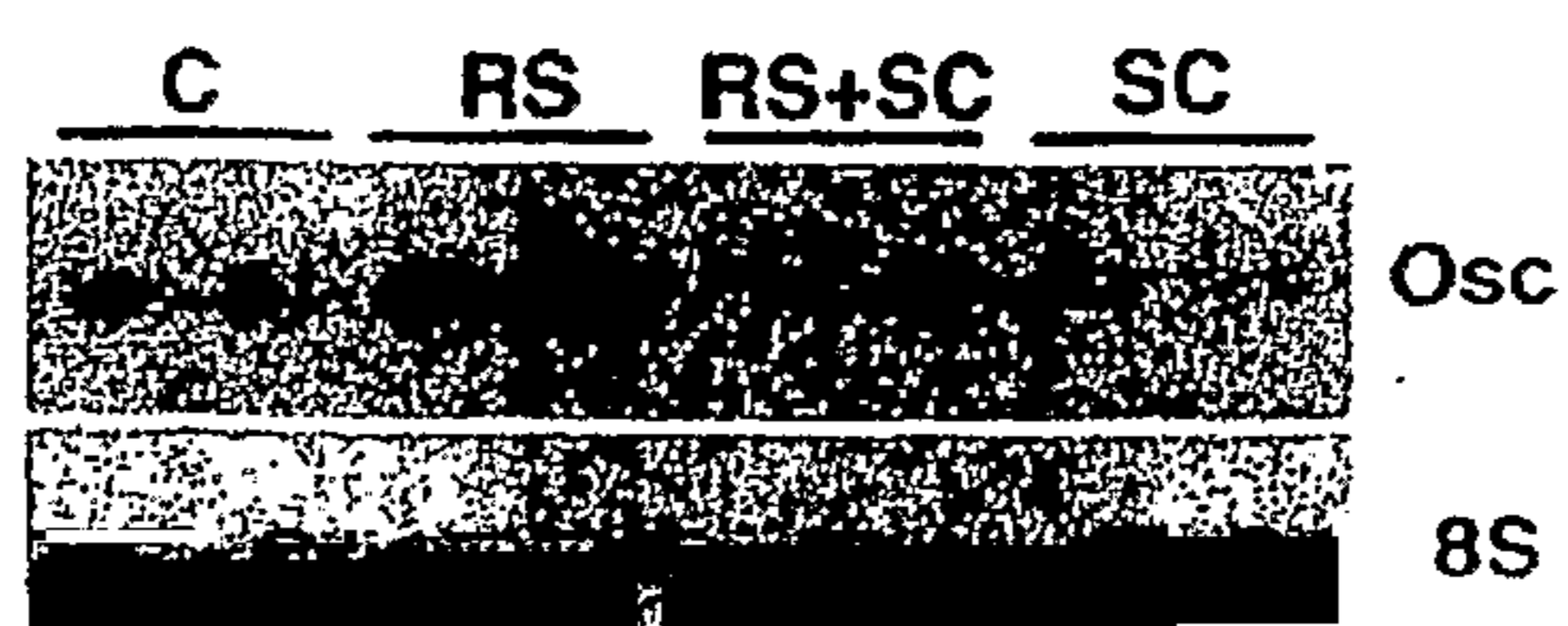

FIG. 9C



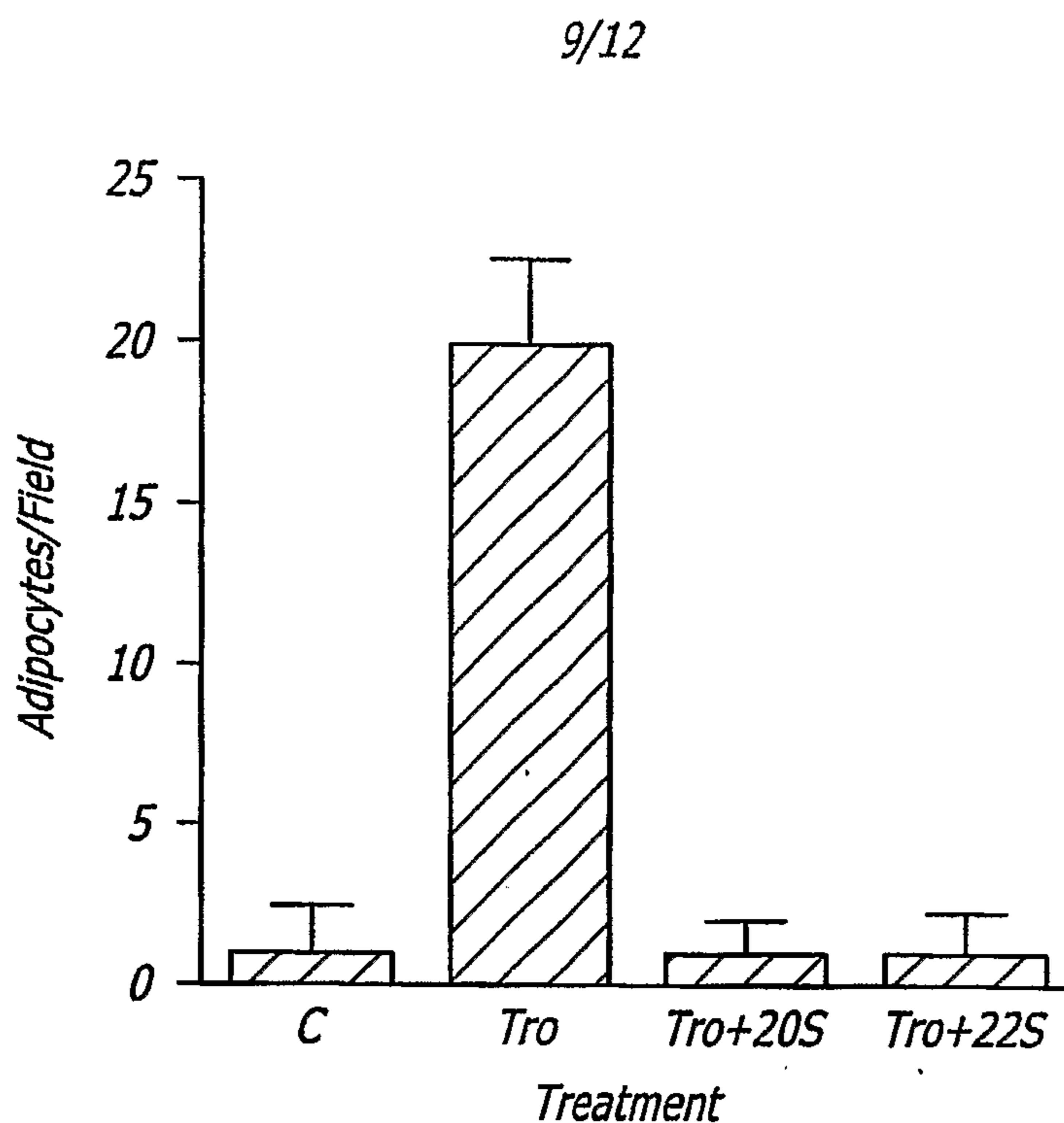

FIG. 7B

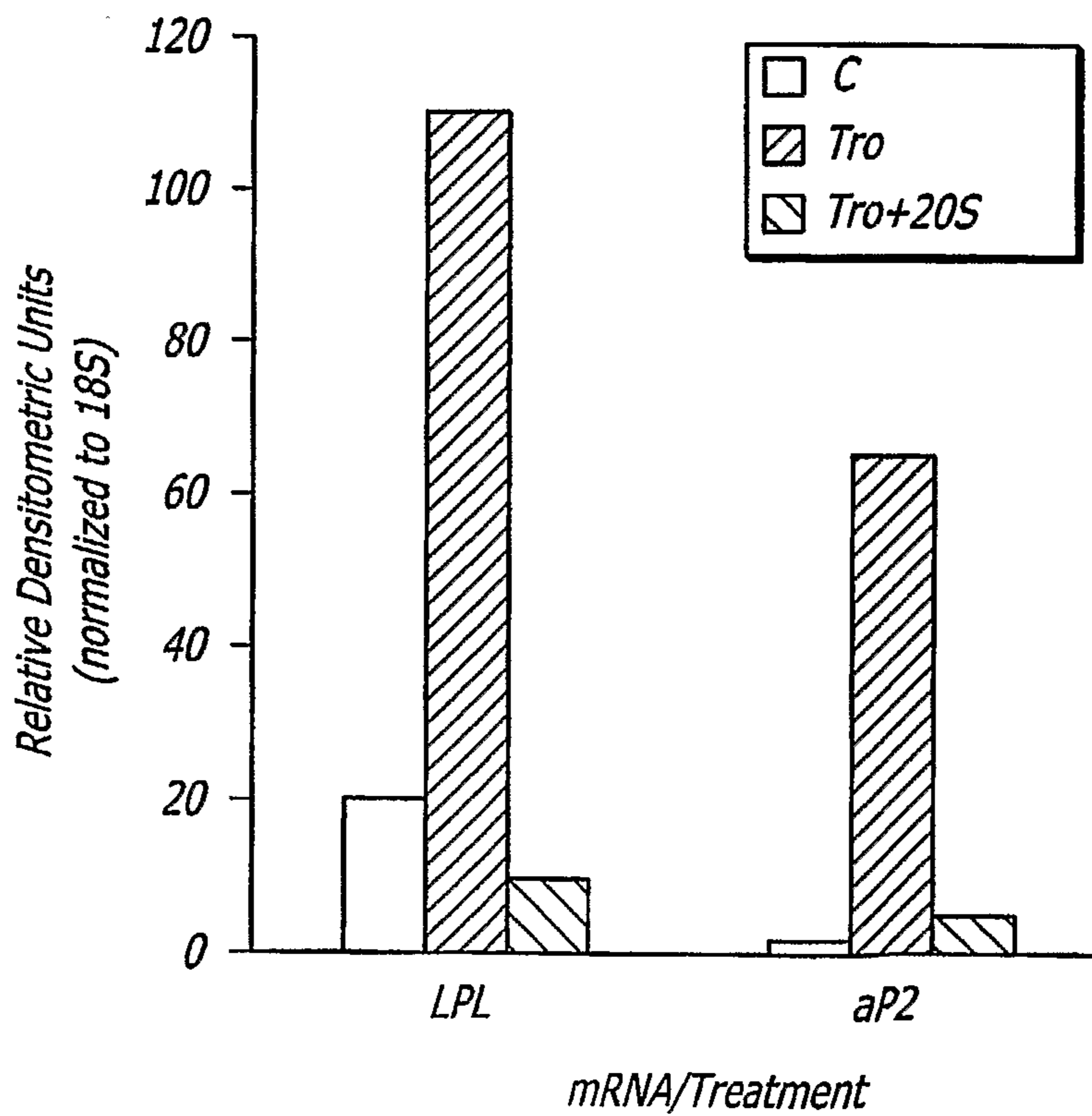

FIG. 7D

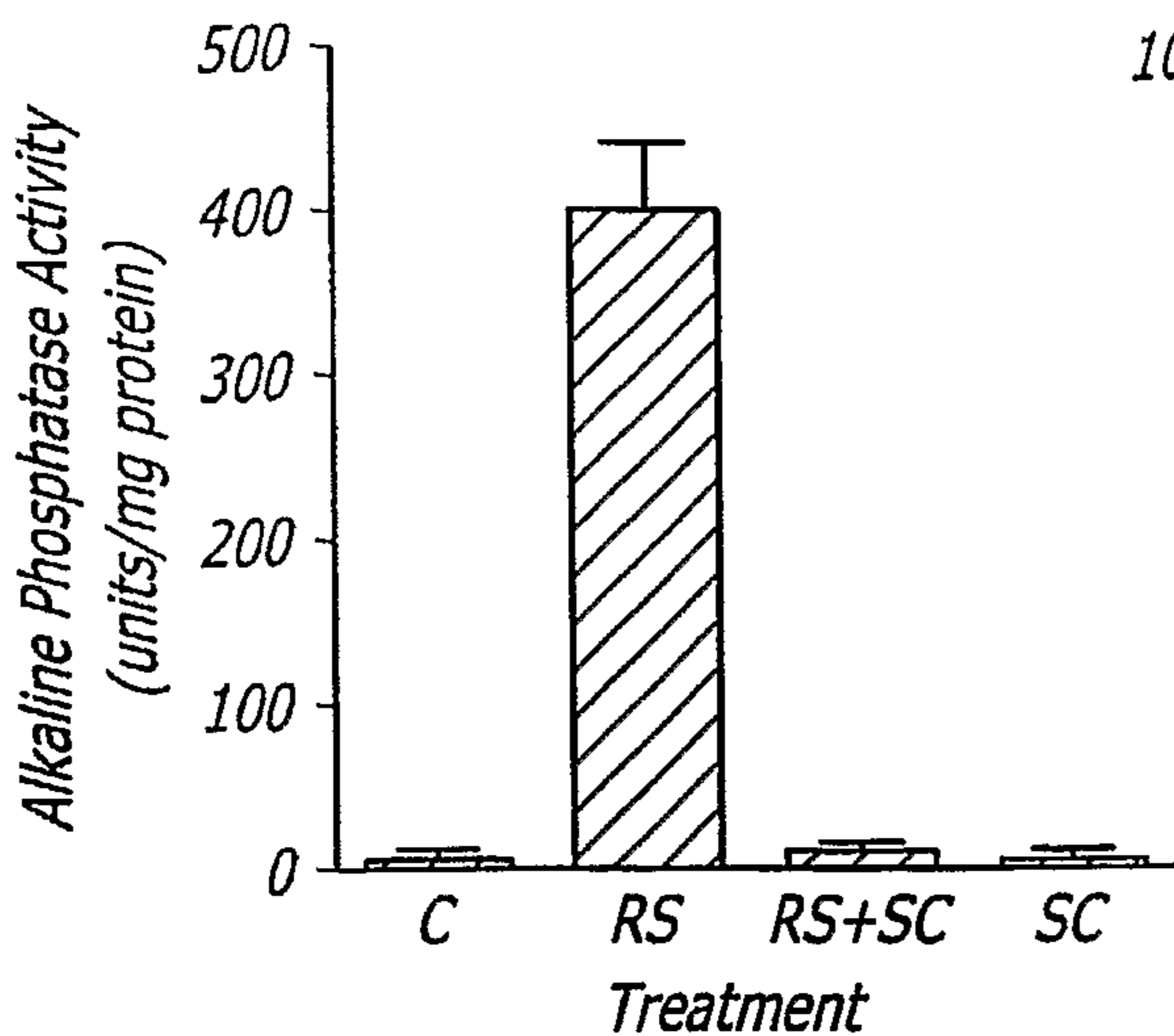

FIG. 9A

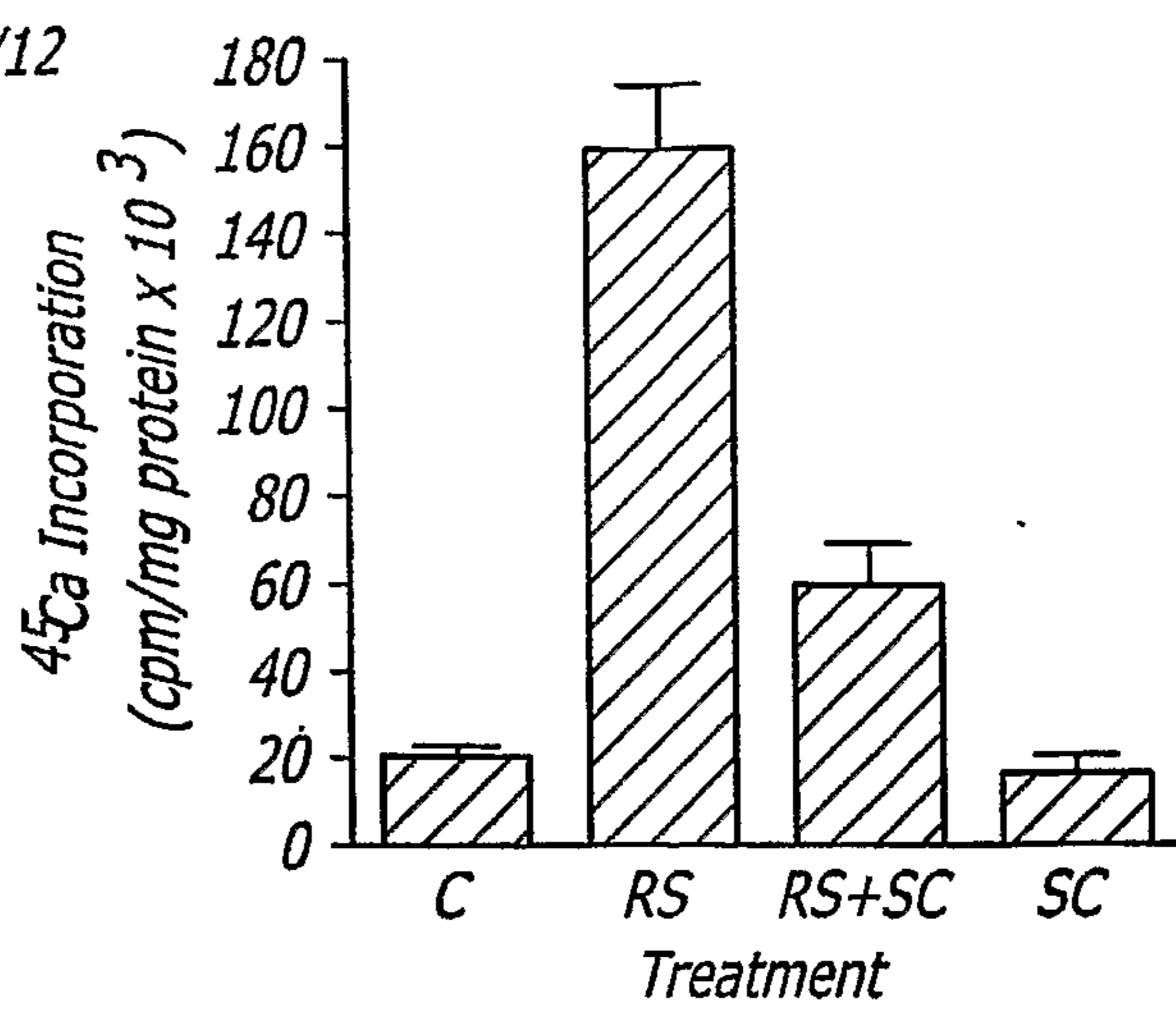

FIG. 9B

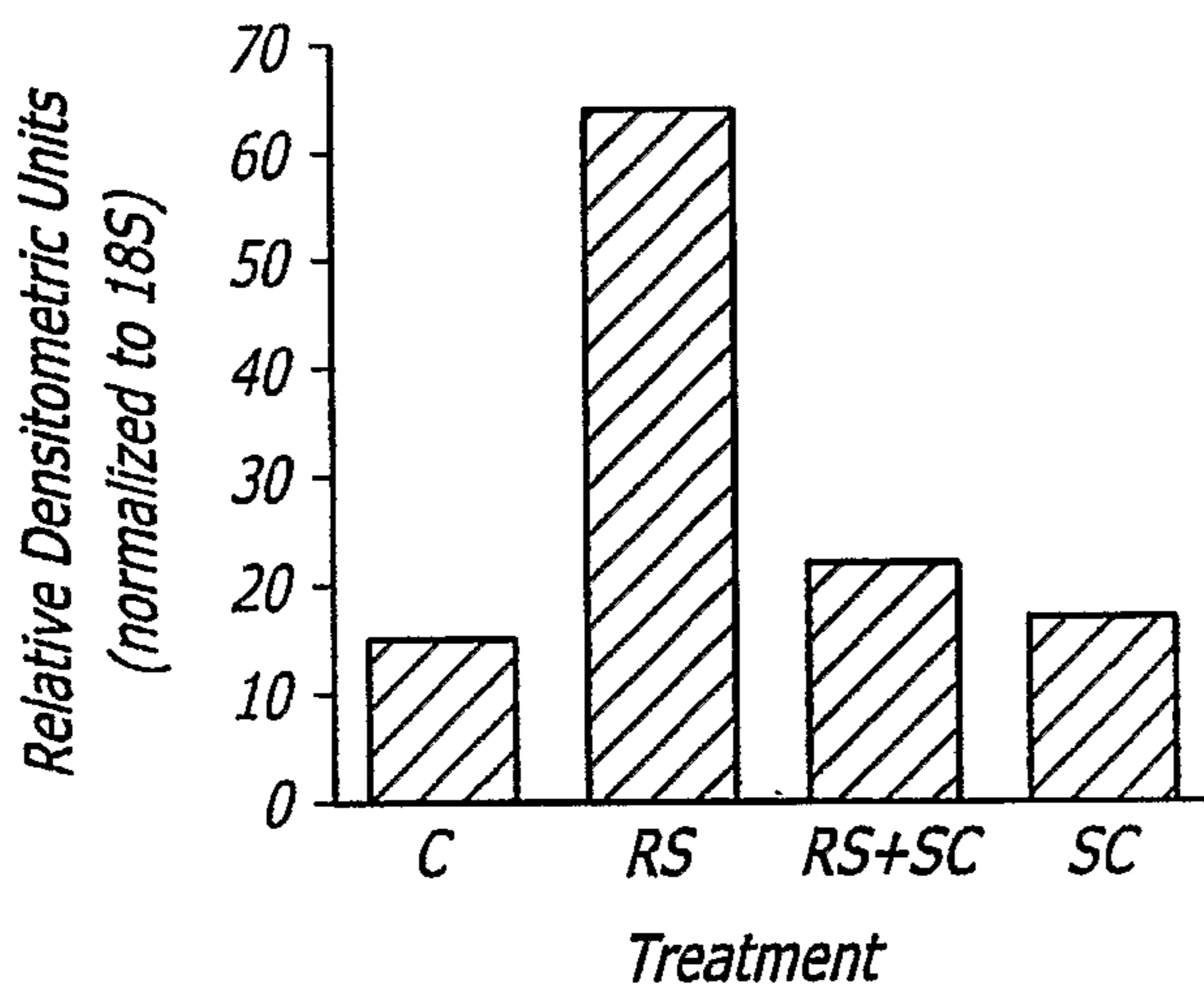

FIG. 9D

FIG. 9E

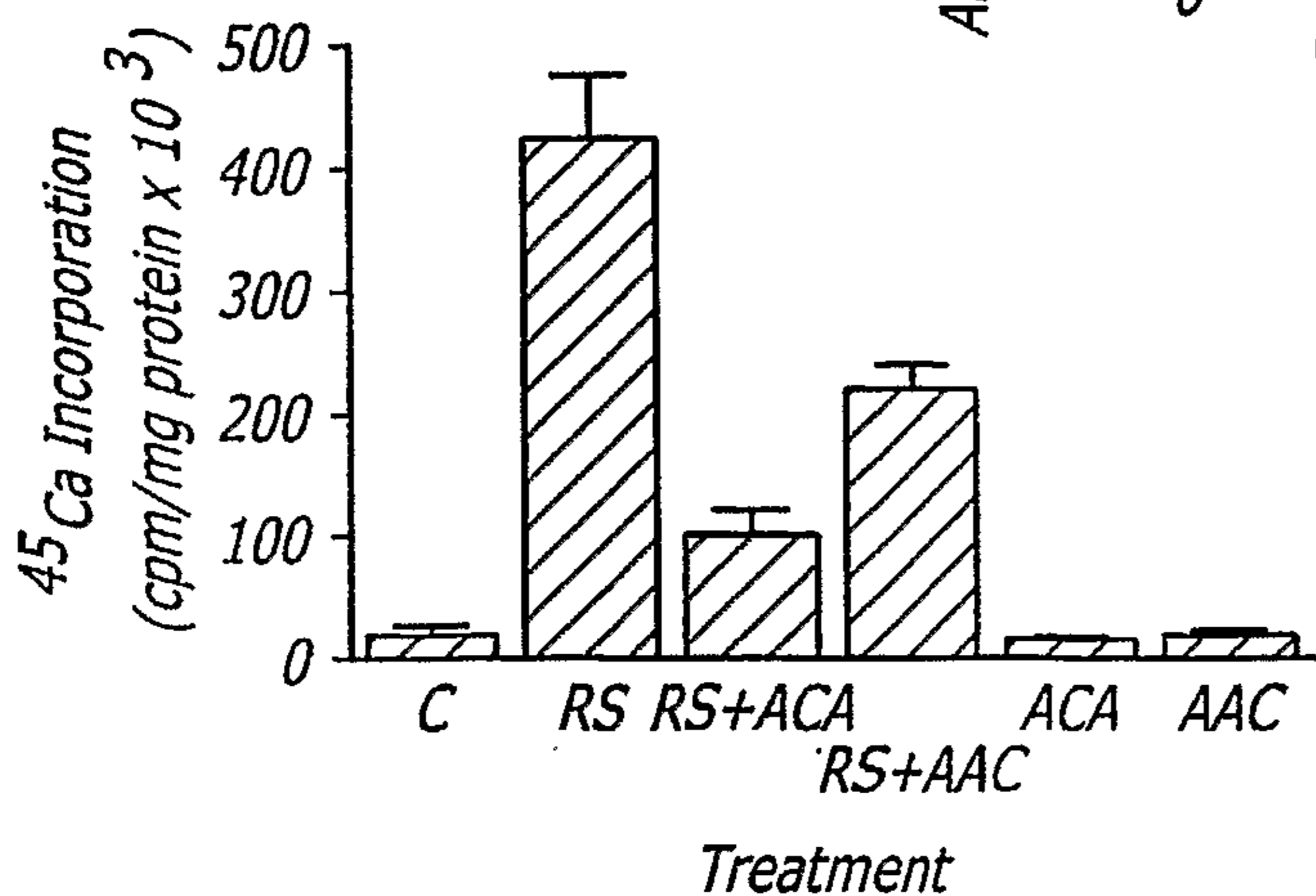
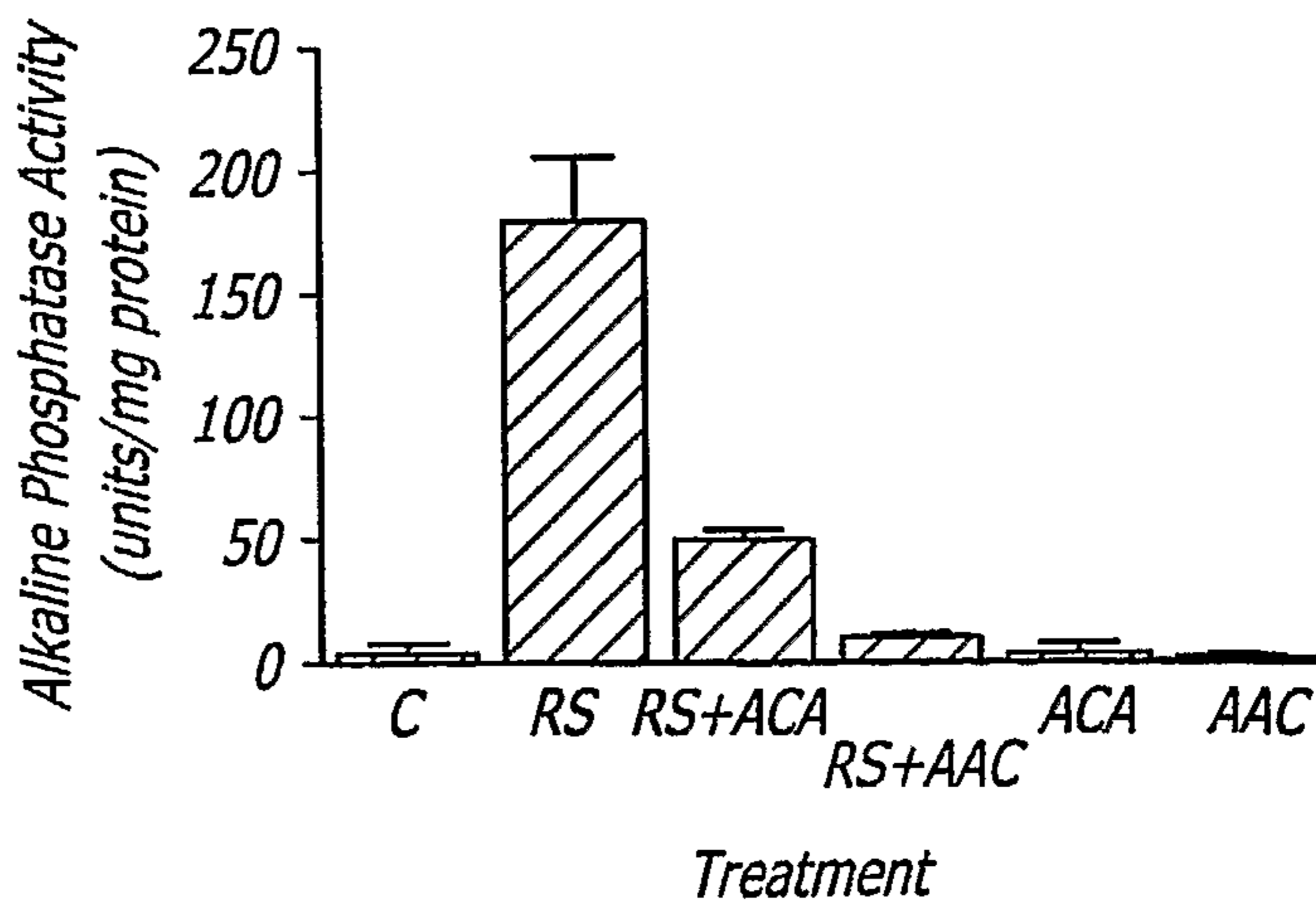

FIG. 9F

11/12

FIG. 10A

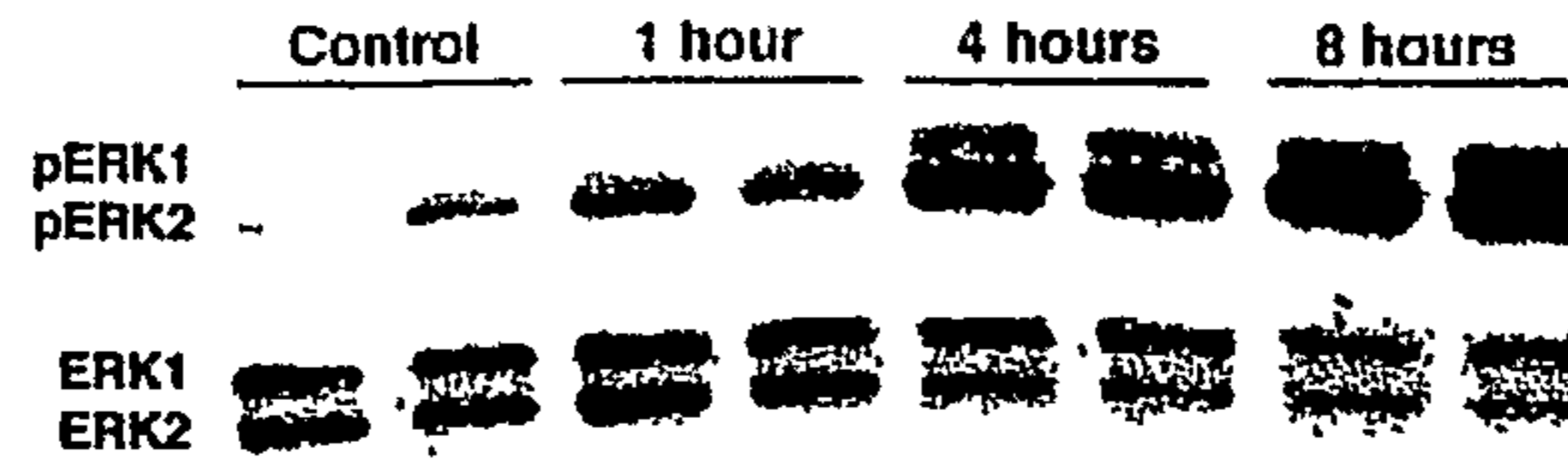

FIG. 11

<u>Treatment</u>	<u>TAr (mm²)</u>	<u>BAr (mm²)</u>	<u>BAr % TAr</u>
Vehicle (n=6)	2135.4 ± 415.8	892.7 ± 279.9	41.0 ± 6.1
22R+20S (n=6)	1730.9 ± 409.5	850.3 ± 202.6	49.3* ± 4.2

FIG. 12A

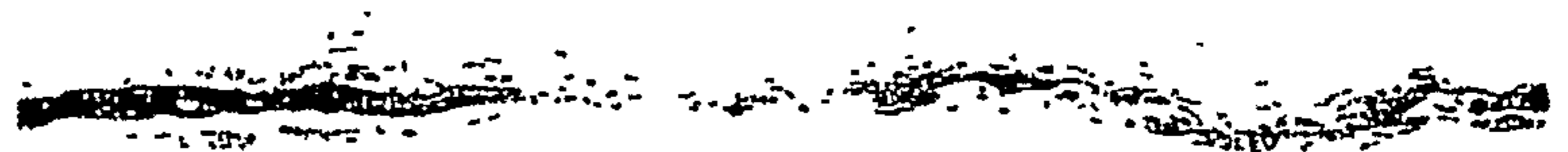
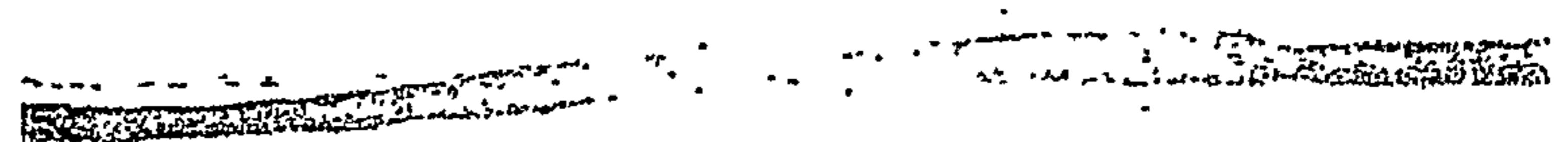

FIG. 12B



0.2 mm

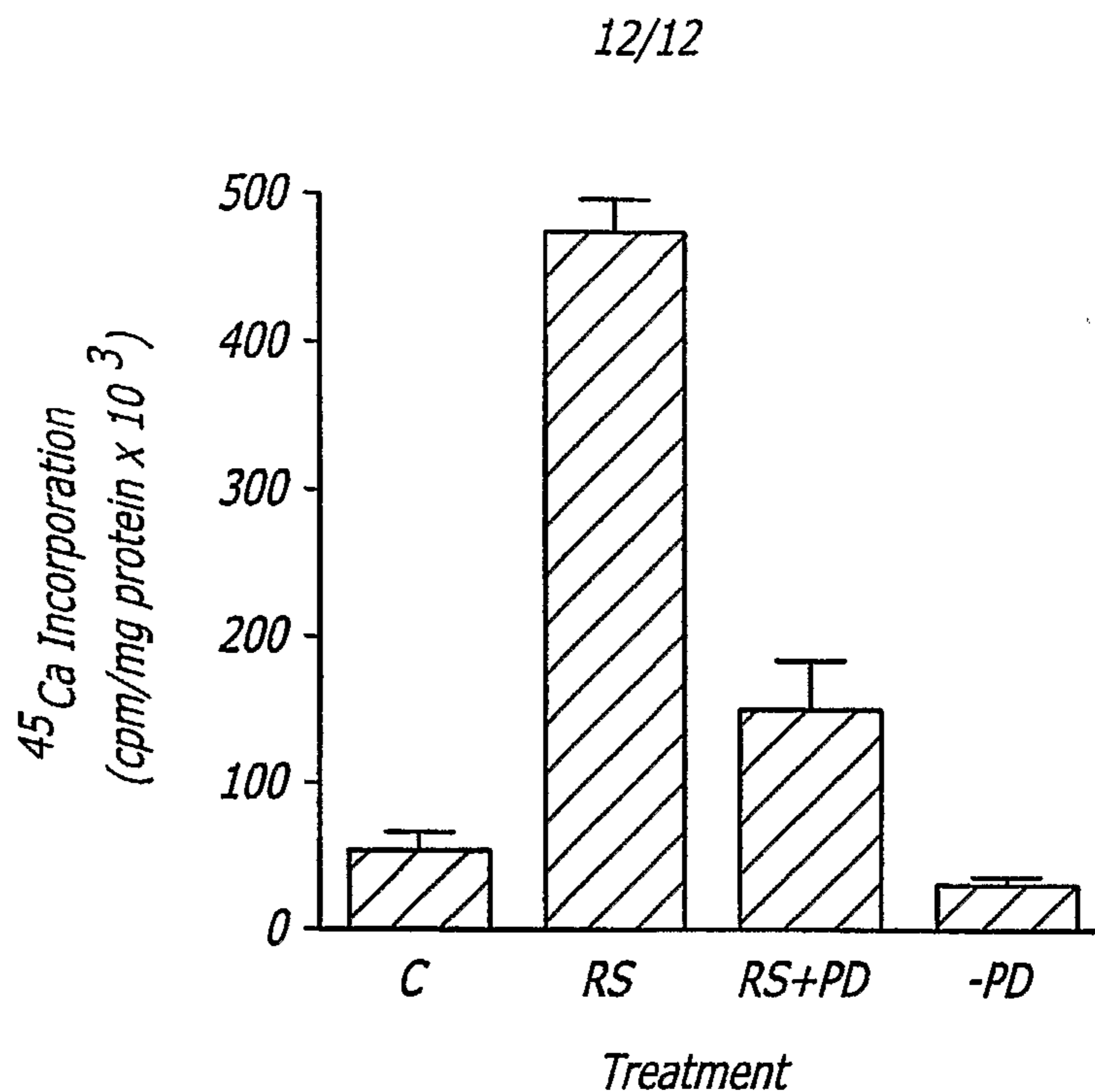

FIG. 10B

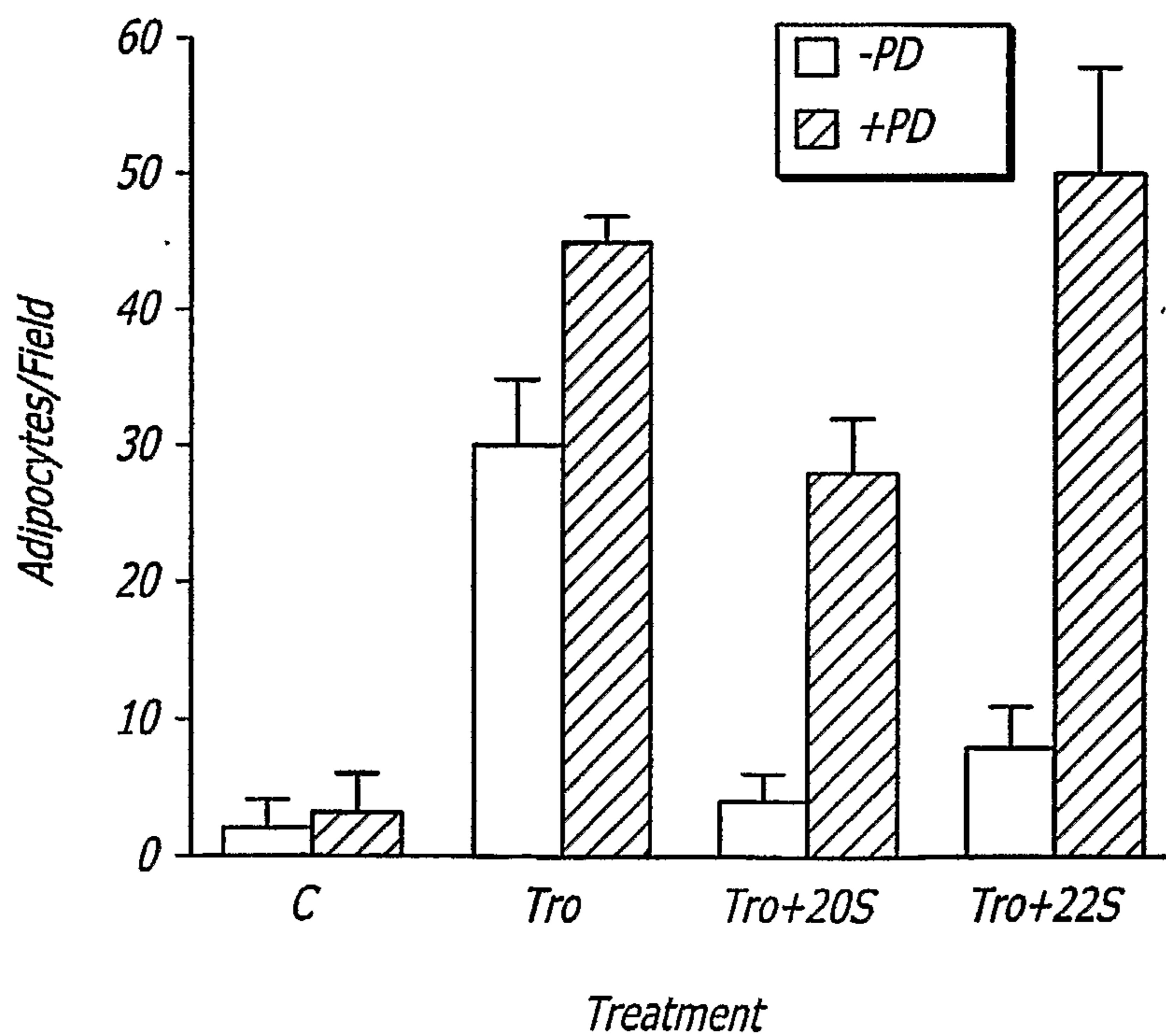

FIG. 10C