



US 20180088562A1

(19) **United States**

(12) **Patent Application Publication**  
**Hintz et al.**

(10) **Pub. No.: US 2018/0088562 A1**  
(43) **Pub. Date: Mar. 29, 2018**

(54) **MACHINING SYSTEM AND METHOD, CONTROL DEVICE AND COMPUTER PROGRAM PRODUCT FOR CONTROLLING A MACHINING SYSTEM WITH A MACHINE TOOL**

**Publication Classification**

(51) **Int. Cl.**  
**G05B 19/418** (2006.01)  
**B23Q 3/155** (2006.01)  
(52) **U.S. Cl.**  
CPC ..... **G05B 19/4187** (2013.01); **B23Q 3/15539** (2016.11); **G05B 2219/50243** (2013.01); **B23Q 2003/15537** (2016.11); **G05B 2219/50008** (2013.01); **G05B 2219/32257** (2013.01)

(71) Applicant: **Siemens Aktiengesellschaft, München (DE)**

(72) Inventors: **Tobias Hintz, Lindenfels (DE); Alexander Pfaffinger, München (DE); Christian Royer, Ottobrunn (DE)**

(21) Appl. No.: **15/566,081**

(57) **ABSTRACT**

(22) PCT Filed: **Apr. 7, 2016**

A machine tool including a first and a second tool magazine, wherein a tool for machining a workpiece can be received from the first tool magazine and a tool from the second tool magazine can be transferred into the first tool magazine, and wherein one of the tools includes a multiple tool that can be fitted with a plurality of tools prior to the machining. A method for controlling a machine tool includes the steps of detecting workpieces to be machined, determining the tools required for machining the detected workpieces and determining the tools, with which the multiple tool is to be fitted.

(86) PCT No.: **PCT/EP2016/057558**

§ 371 (c)(1),  
(2) Date: **Oct. 12, 2017**

(30) **Foreign Application Priority Data**

Apr. 15, 2015 (DE) ..... 10 2015 206 742.4  
May 29, 2015 (DE) ..... 10 2015 209 924.5

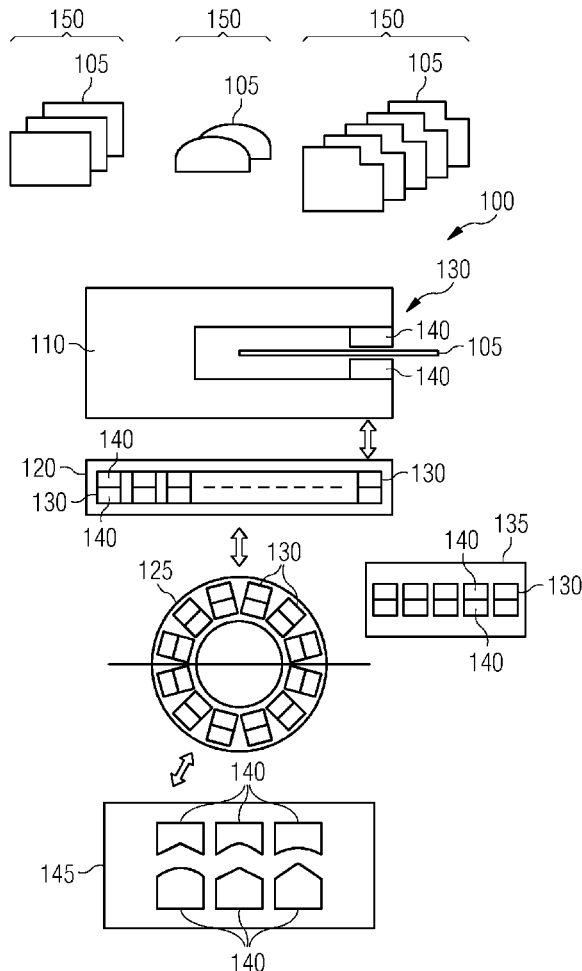

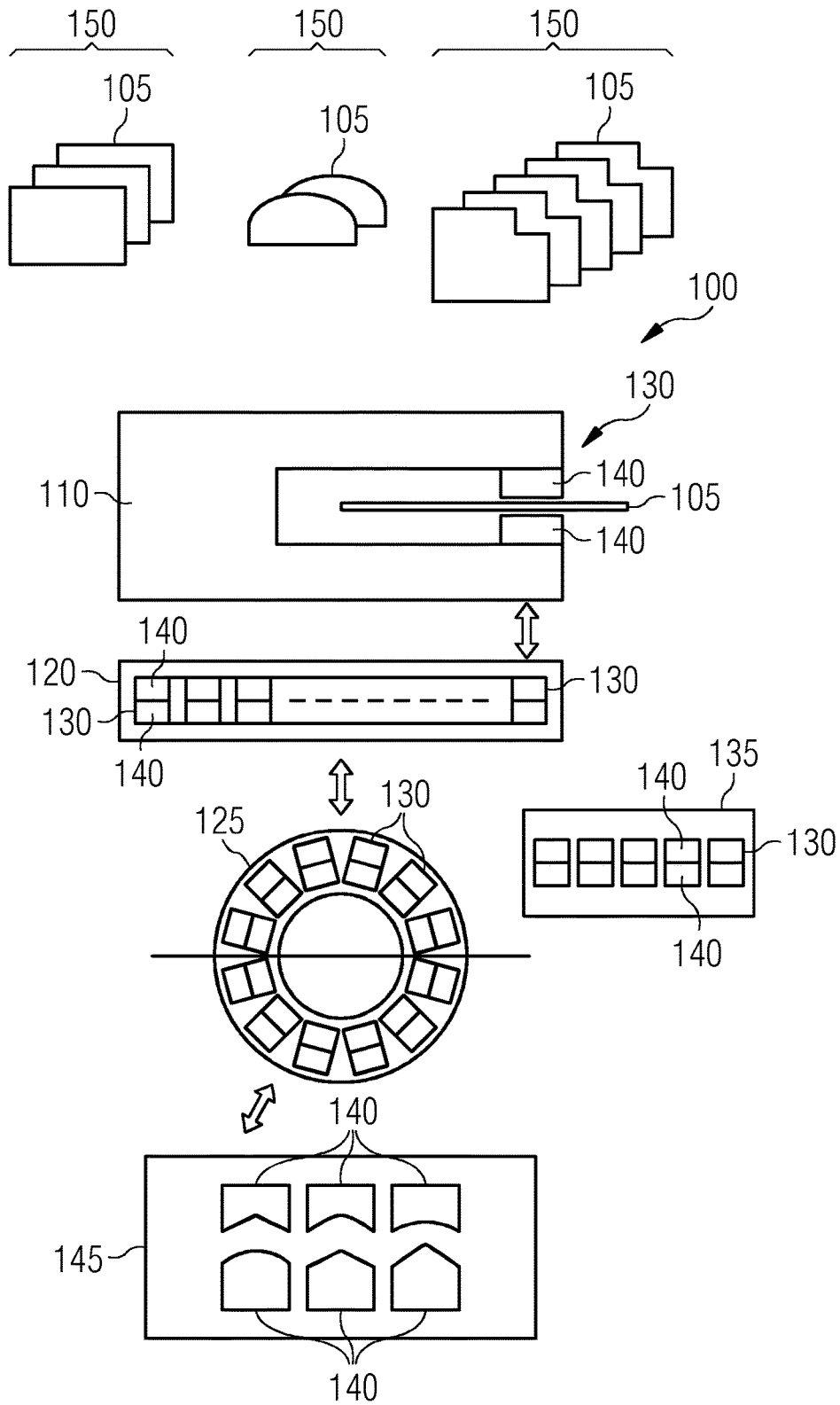

**MACHINING SYSTEM AND METHOD,  
CONTROL DEVICE AND COMPUTER  
PROGRAM PRODUCT FOR CONTROLLING  
A MACHINING SYSTEM WITH A MACHINE  
TOOL**

CROSS-REFERENCE TO RELATED  
APPLICATIONS

**[0001]** This application claims priority to PCT Application No. PCT/EP2016/057558, having a filing date of Apr. 7, 2017, based off of German Application No. DE 102015206742.4 having a filing date of Apr. 15, 2015 and German Application No. 102015209924.5, having a filing date of May 29, 2015 the entire contents of which are hereby incorporated by reference.

FIELD OF TECHNOLOGY

**[0002]** The following relates to a method, a computer program product, a device, and a system for controlling a machine tool.

BACKGROUND

**[0003]** A machine tool is set up to machine a workpiece using different tools one after the other. In particular, the machine tool can comprise a punching machine which machines a flat workpiece, such as a metal sheet. For this purpose, the machine tool can comprise a tool magazine with spaces for storing a predetermined number of tools. The machine tool can pick up one of the tools from the tool magazine and use it to carry out one or more machining steps on the workpiece.

**[0004]** A so-called multi-tool can also be provided, which from the point of view of the tool magazine is treated as a standard tool, but which can be equipped with, for example, up to five or up to ten separate tools, which are then available for machining the workpieces.

**[0005]** In addition, two staggered tool magazines can be provided, wherein the machine tool can access a tool from the first tool magazine relatively quickly. If a tool is to be used that is not located in the first tool magazine, then this can be transferred from the second tool magazine into the first. At the same time, another tool can be replaced from the first to the second tool magazine. Such an access takes a relatively long time, however, for example approximately 20-30 seconds, and this usually has to be carried out not only when machining a single workpiece, but also when machining each workpiece of a job consisting of similar workpieces. Through the use of multi-tools, the capacity of the first tool magazine can be increased so that less frequent tool changes between the first and the second tool magazine may be required.

SUMMARY

**[0006]** A machine tool comprises a first and a second tool magazine, wherein a tool for machining a workpiece can be collected from the first tool magazine and a tool can be transferred from the second tool magazine into the first tool magazine, and wherein one of the tools comprises a multi-tool, which can be equipped with a plurality of tools prior to the machining. A method for controlling a machine tool comprises steps of identifying workpieces to be machined, determining tools that are required for machining the identified workpieces, and determining tools with which the

multi-tool is to be fitted. The tools are determined in such a way that the weighted sum  $l \cdot LC + w \cdot TP$  is minimized over all workpieces to be machined, where LC is the number of the tools that are transferred from the second into the first tool magazine for machining the workpiece, TP is the number of the tools which are to be fitted in one of the tool magazines for machining the workpiece, and l and w represent predetermined weighting factors.

**[0007]** Using the defined criterion, the tools to be used for the multi-tool can be simply and reliably determined. This can involve using a mathematical optimization procedure, for example, wherein the said criterion can be simply and reliably expressed and formed in the optimization procedure. The tools for the multi-tools are preferably formed using mixed integer programming (MIP) methods.

**[0008]** The above sum can also be formed with equal weighting factors l and w, and in particular both weighting factors can be one, so that in practice an unweighted sum is used. In another embodiment, one of the two weighting factors is zero, so that optimization is only performed according to the other criterion. There can also be a plurality of multi-tools provided, whose tools can be determined as specified. Holding capacities of the multi-tools for tools can be the same or different. A further factor that can be taken into account is which of the tools may be used in which multi-tool. The optimization criterion in this case can remain unchanged. The specific assignment of tools to multi-tools can thus be implemented on the machine tool in an improved way.

**[0009]** The determination can also comprise an assignment of tools or multi-tools to the tool magazines. After determination, the tools are usually fitted in the multi-tools and/or the tool magazines before workpieces are machined by means of the machine tool. The machining can also be controlled by the method.

**[0010]** In one variant the possibility exists of fitting two or more identical tools on different multi-tools. In this case the machining of a workpiece is controlled in such a way that only one of the identical tools is used at a time. Each operation on the same workpiece with one of the identical tools is then carried out with the same tool. This means that in some circumstances, additional tool changes can be saved.

**[0011]** In another variant, it is assumed that a tool may be fitted on no more than one multi-tool. If a tool of a multi-tool is usable for a workpiece, then this multi-tool is preferably also used for it.

**[0012]** In both variants, a quantity of multi-tools with already fitted tools can be considered. In the first variant, the use of existing multi-tools can be prohibited for types of workpieces, for which they are currently not being used. The result achieved by this is that tools from new multi-tools are not used unnecessarily, and the number of production programs that must be changed can be kept low.

**[0013]** A computer program product (non-transitory computer readable storage medium having instructions, which when executed by a processor, perform actions) comprises program code means for carrying out the method described above when it is running on an execution device or is stored on a computer-readable medium.

**[0014]** A control device for the above-described machine tool is configured to carry out the steps of the above-described method.

[0015] A machining system comprises the above-described machine tool and the above-described control device.

#### BRIEF DESCRIPTION

[0016] Some of the embodiments will be described in detail; with reference to the following figures, wherein like designations denote like members, wherein:

[0017] FIG. 1 shows a machining system with a machine tool, in accordance with embodiments of the present invention.

#### DETAILED DESCRIPTION

[0018] FIG. 1 shows a machining system 100 for machining workpieces 105. The machining system 100 comprises a machine tool 110 with a control device 115. The machine tool can include in particular a punching machine, for example a Trumatic 5000 or Trumatic 7000.

[0019] The machine tool 110 comprises a first tool magazine 120 (linear magazine) and optionally a second tool magazine 125 (round magazine, Toolmaster), each for holding a predetermined number of tools 130. If the machine tool 110 is a Trumatic 5000, for example, then the holding capacity of the first tool magazine 120 is currently 21 and that of the second tool magazine 125 is 50 tools 130. In the case of the Trumatic 7000 the first tool magazine 120 currently holds 25 and the second tool magazine 125 holds 70 tools 130.

[0020] The machine tool 110 is configured to machine a workpiece 105 by means of one or more tools 130, which it can collect automatically from the first tool magazine 120 one after another. Such a tool change proceeds relatively quickly, usually taking an estimated approx. 1-10 seconds. From the second tool magazine 125, a tool 130 can be transferred into the first tool magazine 120, wherein a different tool 130 is usually replaced from the first tool magazine 120 to the second 125. This process typically takes considerably longer, for example approximately 20-30 seconds, and is also called a linear magazine change.

[0021] If a workpiece 105 is to be machined which requires more tools 130 than can be held in the first tool magazine 120, such a change is necessary. If a number of identical workpieces 105 are machined one after the other, then this exchange—and where appropriate, a corresponding replacement—must be carried out for each individual workpiece 105.

[0022] The second tool magazine 125 can be configured to be retrofitted or refitted with tools 130 during the machining of a workpiece 105 using the machine tool 110, wherein individual tools 130 from the second tool magazine 125 can be removed or added. The second tool magazine 125 can be organized in a circular manner, for example, wherein in a first circle segment a retrofitting or refitting can be performed, and in a second circle segment different from the first, an exchange of tools 130 with the first tool magazine 120 can take place.

[0023] To reduce the number of spaces provided for tools 130 in the tool magazines 120, 125, multi-tools 135 can be provided, each of which only occupies the space of a single tool 130 in the tool magazines 120, 125, but in turn can accommodate a plurality of tools 130. The storage capacity

of the multi-tools 135 is in this case limited, for example, multi-tools 135 can be provided for a maximum of five or a maximum of ten tools 130.

[0024] Because of their dimensions, it is often the case that not all tools 130 are suitable for being accommodated in a multi-tool 135. The usability of a tool 130 in a multi-tool 135 can be based on the packing density of tools 130 in the multi-tool 135, so that a tool 130 that can be fitted in a 10-way multi-tool 135 can usually also be fitted in a 5-way multi-tool 135, but possibly not vice versa.

[0025] Some of the tools 130 can also be composed of two or more parts 140. For example, for a punching, embossing or deep drawing process, one part 140 can comprise a die and another part 140 can comprise a stamp. For a predefined machining operation on a workpiece 105, the required tool 130 can require different parts 140, for example, depending on the material thickness of the workpiece 105, to ensure a predetermined clearance. The clearance depends on the distance between the parts 140 of the tool 130, in which the workpiece 105 is located when being machined. A tool 130 can also be used for a range of parameters, for example for workpieces 105 with a material thickness of approximately 0.8 to 1.5 mm. Depending on the material or any other parameter of the workpiece 105, different parts 140 can also be required to form a suitable tool 130.

[0026] The individual parts 140 can be kept in an inventory 145, which is implemented as a storage system, for example. If ready assembled tools 130 are also held in the inventory 145, when equipping the tool magazines 120, 125 with tools 130, only a part of them need to be installed in advance.

[0027] To fit a tool 130 in one of the tool magazines 120, 125 or in a multi-tool 135, all the parts 140 required for it must usually be determined and obtained from the inventory 145; then the parts 140 must be joined to the tool 130, which is generally performed manually. Usually, when fitting a tool 130, another one must also be removed to free up space in the tool magazine 120, 125 or the multi-tool 135. A removed tool 130 is usually disassembled back into its parts 140 and the parts 140 are moved back into the inventory 145. The removal can also be understood as a part of the tool fitting. The entire process is also known as tool preparation or single-tool preparation, and can take place in a dedicated pre-fitting area, which is usually further away from the machine tool 110 than the second tool magazine 125. The provision of a tool 130 from parts 140 of the inventory 145 is time-consuming and labor-intensive. The process of providing a tool normally takes several minutes to several tens of minutes.

[0028] The machine tool 110 is usually not only used to machine individual workpieces 105, but jobs 150, wherein a batch of identical workpieces 105 which are machined in the same way, i.e. using the same tools 130, is assigned to each job 150. For producing a single workpiece 105, the number of units for the associated job 150 can also be equal to one. Workpieces 105 of a job 150 are usually machined one after the other, without the number of fitted tools 130 being changed.

[0029] Jobs 150, or workpieces 105, that can be machined using the machine tool 110 without a change in the tools 130 fitted in the tool magazines 120, 125, can be termed a setup group 155. The quantity of the tools 130 fitted in this way is also called a tool set 160.

[0030] For machining workpieces 105, a conveyor unit (not shown) can be provided, which feeds unmachined workpieces 105 into the machine tool 110 automatically one after another and/or removes machined workpieces 105. The machine tool 110 can thus be operated unattended for fairly long periods.

[0031] The idea underlying embodiments of the invention is to select the tools 130 that are fitted in a multi-tool 135 in such a way that the machine tool 110 can be operated as efficiently as possible and fitting or refitting operations of the tool magazines 120, 125 are minimized as far as possible. To this end, a particular aim is to assign the tools 130 to multi-tools 135 using the methods of integer-based or Mixed Integer Programming (MIP).

[0032] Embodiments of the invention will now be explained in more detail in a mathematical way.

(I) Labels

[0033] In the following MIP formulations, the following terms are used.

[0034] Indices

[0035]  $C$  quantity of workpieces 105 to be machined on the machine tool 110

[0036]  $T$  quantity of all tool stamps 140

[0037]  $T_c$  quantity of tool stamps 140 which are required for the workpieces 105 of type  $c$

[0038]  $MT$  quantity of multi-tools 135 (both embossing and punching multi-tools 135) to be newly assembled

[0039]  $MT_c$  quantity of new multi-tools 135 which can be used for a workpiece 105 of type  $c$  (punching multi-tools 135 can only be used with material thicknesses of the workpiece 105 of between 0.8 and 1.5 mm, while embossing multi-tools 135 can be used for all material thicknesses)

[0040]  $T_{mt}$  quantity of tool stamps 140 that may be used in multi-tools 130  $mt$  (e.g., punching tools 130 may only be used in punching multi-tools 135 and embossing tools 130 only in embossing multi-tools 135)

[0041]  $S$  possible clearance values

[0042]  $S_c$  possible clearance values for workpieces 105 of type  $c$

[0043] Parameters

[0044]  $nBoards_c$  number of workpieces 105 of type  $c$  to be manufactured

[0045]  $nSetup_c$  number of refittings of workpieces 105 of type  $c$

[0046]  $linCap$  capacity of the linear magazine 120 of the given machine tool 110

[0047]  $nTools_{mt}$  number of tools 130 which can be accommodated in multi-tool 130  $mt$

[0048]  $W_{Lin}$  weighting of the objective "Maximize savings in linear magazine changes"

[0049]  $W_{Prep}$  weighting of the objective "Maximize savings in tool preparation costs"

[0050] Binary Variables

[0051]  $Assign_{t,s,mt}$  variable indicating whether a tool stamp 140  $t$  with the clearance  $s$  can be fitted on the multi-tool 135  $mt$ . (In this case, it takes the value 1, otherwise the value 0)

[0052]  $IsUsed_{c,mt}$  variable indicating whether the multi-tool 135  $mt$  is used for workpieces 105 of type  $c$ . (In this case, it takes the value 1, otherwise the value 0)

[0053]  $Process_{c,t,mt}$  variable indicating whether the punching operations, which must be performed for workpiece

105  $c$  with tool stamp 140  $t$ , are made by multi-tool 135  $mt$ . (In this case, it takes the value 1, otherwise the value 0)

[0054] Additional Auxiliary Variables

[0055]  $NToolMTs_c$  number of individual tools 130 in the multi-tools 135, which are used for a workpiece 105 of type  $c$

[0056]  $SavedTools_c$  number of physical tools 130 required for the production of workpieces 105 of type  $c$ , which have been saved

[0057]  $NLinChanges_c$  number of linear magazine changes used in the machining of workpieces of type  $c$

[0058]  $NToolPreps_c$  number of tool preparations for the machining of workpieces of type  $c$

[0059] (II.) IP Formulation for the Model with Unique Tool Stamp Assignments

[0060] In this model a maximum of one tool stamp 140 may be fitted on one multi-tool 135. If a tool 130 of a multi-tool 135 is usable for a workpiece 105, then this multi-tool 135 is also used for it.

$$\text{minimize } \sum_{c \in C} \left( w_{Lin} NLinChanges_c + w_{Prep} NToolPreps_c \right)$$

s.t.:

$$(1) \sum_{c \in C} \sum_{mt \in MT} Assign_{c,t,mt} \leq nTools_{mt} \quad mt \in MT$$

$$(2) \sum_{c \in C} \sum_{mt \in MT} Assign_{c,t,mt} \leq nTools_{mt} IsUsed_{c,mt} \quad c \in C, mt \in MT$$

$$(3) \sum_{t \in T} \sum_{mt \in MT} Assign_{c,t,mt} \leq 1r \quad t \in T$$

$$(4) NToolsInMTs_c = \sum_{t \in T} \sum_{mt \in MT} Assign_{c,t,mt} \quad c \in C$$

$$(5) SavedTools_c = NToolsInMTs_c - \sum_{mt \in MT} IsUsed_{c,mt} \quad c \in C$$

$$(6) NLinChanges_c \geq nBoards_c \left( |T_c| - SavedTools_c - linCap \right) \quad c \in C$$

$$(7) NToolPreps_c = nSetup_c \left( |T_c| - NToolsInMTs_c \right) \quad c \in C$$

$$(8) Assign_{c,t,mt} = 0$$

$$mt \in MT, s \in S, t \in T \setminus T_{mt}$$

$$(9) IsUsed_{c,mt} = 0$$

$$c \in C, mt \in MT \setminus MT_c$$

$$Assign_{c,t,mt} \in \{0, 1\}$$

$$t \in T, s \in S, mt \in MT$$

$$IsUsed_{c,mt} \in \{0, 1\}$$

$$c \in C, mt \in MT$$

$$NToolsInMTs_c \geq 0$$

$$c \in C$$

$$\begin{aligned}
& \text{-continued} \\
& \text{SavedTools}_{\text{c}} \geq 0 \\
& \quad c \in C \\
& \text{NLinChanges}_{\text{c}} \geq 0 \\
& \quad c \in C \\
& \text{NToolPreps}_{\text{c}} \geq 0 \\
& \quad c \in C
\end{aligned}$$

Ⓜ indicates text missing or illegible when filed

**[0061]** Explanations:

**[0062]** For (1): No more than the specified number of individual tools **130** may be installed on a multi-tool **135** mt. Usually there are 5 or 10 individual tools **130**, depending on the type of multi-tool **135**.

**[0063]** For (2): If a tool stamp **140** t is fitted on a multi-tool **135** mt, then the multi-tool **135** is used for each possible workpiece **105** in terms of clearance that requires this tool stamp **140**.

**[0064]** For (3): A tool stamp **140** must be fitted on no more than one multi-tool **135**.

**[0065]** For (4): Per workpiece **105**, or type of workpiece **105**, the number of the tools **130** used in the multitools **135** is the sum of all tools **130** fitted in the multi-tools **135** with matching stamp **140** and matching clearance.

**[0066]** For (5): Per workpiece **105**, or type of workpiece **105**, the saving of the tools **130** required corresponds to the number of usable individual tools **130** fitted in the multi-tools **135** (tool stamp **140** with permissible clearance) minus the number of multi-tools **135** used.

**[0067]** For (6): If the number of tool stamps **140** ( $=T_c / \text{SavedTools}_c$ ) required for a workpiece **105** or type of workpiece **105** is less than or equal to the capacity of the linear magazine **120**, then there is no linear magazine change. In the other case, the number of linear magazine changes is the difference in the number of required tool stamps **140** and the capacity of the linear magazine **120**, multiplied by the number of units of the workpiece **105** to be manufactured.

**[0068]** For (7): Per workpiece **105** the number of individual tool preparations corresponds to the number of required tool stamps **140** which are not fitted in the multi-tools **135**, multiplied by the number of refittings of the workpiece **105**. This latter number can correspond to the number of workpieces **105** in a job **150** that are to be machined.

**[0069]** For (8): Tool stamps **140** may only be fitted onto multi-tools **135** that are permissible for them. Examples: stamping tools **130** may only be fitted on stamping multi-tools **135**. On 10-way multi-tools **135**, only tool stamps **140** permitted for 10-way multi-tools may be fitted.

**[0070]** For (9): Multi-tools **135** may only be used for workpieces **105** for which they are also permissible (cf. the definition of  $MT_c$ )

**[0071]** (III.) IP formulation of the model in which one tool stamp may be fitted on a plurality of multi-tools

**[0072]** In this model it is possible to fit two identical tools **130** onto two different multi-tools **135**. This means that in some circumstances, additional linear magazine changes can be saved.

**[0073]** If there is a usable tool **130** for a workpiece **105** on a multi-tool, then one of the multi-tools **135** is definitely used. It must also be determined with which multi-tool **135** such a workpiece **105** is used. Therefore, the  $Process_{c,t,mt}$  variables are also required.

$$\text{minimize} \sum_{c \in C} (w_{lin} \text{NLinChanges}_c + w_{prep} \text{NToolPreps}_c)$$

s.t.:

$$(1) \sum_{\text{c}} \sum_{\text{mt}} \text{Assign}_{\text{c}} \leq n \text{Tools}_{\text{mt}} \quad \text{mt} \in MT$$

$$(2) \sum_{\text{c}} \sum_{\text{mt}} \text{Assign}_{\text{c}} \geq \text{Process}_{\text{c}} \quad c \in C, t \in T_{\text{c}}, \text{mt} \in MT_{\text{c}}$$

$$(3) \sum_{\text{c}} \sum_{\text{mt}} \text{Process}_{\text{c}} \leq |T_c| \text{IsUsed}_{\text{mt}}$$

$$c \in C, \text{mt} \in MT_{\text{c}}$$

$$(4) \sum_{\text{c}} \text{Process}_{\text{c}} \leq 1$$

$$c \in C, t \in T_{\text{c}}$$

$$(5) \text{NToolsInMTs}_{\text{c}} = \sum_{\text{mt}} \sum_{\text{t}} \text{Process}_{\text{c}} \quad c \in C$$

$$(6) \text{SavedTools}_{\text{c}} \geq \text{NToolsInMTs}_{\text{c}} - \sum_{\text{mt}} \text{IsUsed}_{\text{mt}} \quad c \in C$$

$$(7) \text{NLinChanges}_c \geq n \text{Boards}_{\text{c}} \left( |T_c| - \text{SavedTools}_{\text{c}} - \text{linCap} \right) \quad c \in C$$

$$(8) \text{NToolPreps}_{\text{c}} = n \text{Setup}_{\text{c}} \left( |T_c| - \text{NToolsInMTs}_{\text{c}} \right) \quad c \in C$$

$$(9) \text{Assign}_{\text{c}} = 0$$

$$\text{mt} \in MT, s \in S, t \in T \setminus T_{\text{c}}$$

$$(10) \text{IsUsed}_{\text{mt}} = 0$$

$$c \in C, \text{mt} \in MT \setminus MT_{\text{c}}$$

$$(11) \text{Process}_{\text{c}} = 0$$

$$c \in C, \text{mt} \in MT \setminus MT_{\text{c}}, t \in T_{\text{c}}$$

$$c \in C, \text{mt} \in MT_{\text{c}}, t \in T_{\text{c}} \setminus T_m,$$

$$\text{Assign}_{\text{c}} \in \{0, 1\}$$

$$t \in T, s \in S, \text{mt} \in MT$$

$$\text{IsUsed}_{\text{mt}} \in \{0, 1\}$$

$$c \in C, \text{mt} \in MT$$

$$\text{Process}_{\text{c}} \in \{0, 1\}$$

$$c \in C, t \in T_{\text{c}}, \text{mt} \in MT$$

$$\text{NToolsInMTs}_{\text{c}} \geq 0$$

$$c \in C$$

$$\text{SavedTools}_{\text{c}} \geq 0$$

$$c \in C$$

$$\begin{aligned}
& \text{-continued} \\
& NLinChanges_{\text{?}} \geq 0 \\
& c \in C \\
& NPreps_{\text{?}} \geq 0 \\
& c \in C
\end{aligned}$$

? indicates text missing or illegible when filed

[0074] Explanations:

[0075] For (1): On a multi-tool **135** *mt* only a limited number of tools **130** can be fitted, which is usually 5 or 10 tools **130**, depending on the type of the multi-tool **135**.

[0076] For (2): For a tool stamp **140** *t* required for workpieces **105** of type *c*, only one multitool **135** *mt* may be used, on which a tool **130** is fitted with this stamp **140** and with a permissible clearance.

[0077] For (3): A multitool **135** *mt* is used for workpieces **105** of type *c* if at least one tool **130** of the multi-tool **135** is used for the type of workpieces **105**.

[0078] For (4): The operations on workpieces **105** of type *c* that must be performed with the tool stamp **140** *t* may not be used by more than one multi-tool **105**.

[0079] For (5): Per type of workpiece **105**, the number of the tools **130** used in the multi-tools **135** is the sum of all tools **130** fitted in the multi-tools **135** with matching stamp **140** and matching clearance.

[0080] For (6): Per type of workpiece **105**, the saving of the tools **130** required corresponds to the number of individual tools **130** fitted in and used for the multi-tools **135** (tool stamp **140** with permissible clearance) minus the number of multi-tools **135** used.

[0081] For (7): If the number of the tool stamps **140** ( $=|T_c| - \text{SavedTools}_c$ ) required for a type of workpieces **105** is less than or equal to the capacity of the linear magazine **120**, then there is no linear magazine change. In the other case, the number of linear magazine changes is the difference in the number of required tool stamps **140** and the capacity of the linear magazine **120**, multiplied by the number of units of the type of workpieces **105** to be manufactured.

[0082] For (8): Per type of workpieces **105** the number of individual tool preparations corresponds to the number of required tool stamps **140** which are not fitted in the multi-tools **135**, multiplied by the number of fittings of the type of workpieces **105**.

[0083] For (9): No impermissible tool stamps **140** may be fitted on the multi-tools **135**. Examples: stamping tool stamps **140** may only be fitted on stamping multi-tools **135**. On 10-way multi-tools **135**, only tool stamps **140** permitted for 10-way multi-tools **135** may be fitted.

[0084] For (10): Multi-tools **135** must not be used for types of workpieces **105** for which they are impermissible (cf. the definition of  $MT_c$ ).

[0085] For (11): Punching operations which must be performed for a workpiece **105** *c* with tool **130** *t* cannot be performed by multi-tool **135** *mt* if the tool **130** is not permitted on the multi-tool **135** *mt*, or if multi-tool **135** *mt* is not permitted for workpiece **105** *c* in principle.

[0086] (IV.) 3.2 Extension: Consideration of Existing Multi-Tools

[0087] An application case found in practice is also that a configured multi-tool **135** is already present and further-

more, one or a plurality of additional new multi-tools **135** are to be configured. Both preceding models (cf. II and III) can be adapted to also be able to handle this case.

[0088] If tool stamps **140** are not fitted on the existing multi-tools **135** multiple times and if the intention is not to change the use of the current multi-tools **135**, i.e. they will continue to be used for the types of workpieces **105** for which they are currently being used, then the model of section 3.2 may be extended as follows:

[0089] The quantity of multi-tools **135** now consists of the quantity of the already existing multi-tools **135** and the new multi-tools **135**.

[0090] The configurations of the already existing multi-tools **135** already exist. The variables  $Assign_{t,s,mt}$  for these multi-tools **135** must be set to the corresponding values in additional constraints.

[0091] In the model of section III., in which one tool stamp **140** may be fitted on a plurality of multi-tools **135**, existing multi-tools **135** can also be taken into account. If one wants to allow tool stamps **140** which are fitted in existing multi-tools **135** on new multi-tools **135** also, then the model must be adapted as follows:

[0092] The quantity of multi-tools **135** now consists of the quantity of the already existing multi-tools **135** and the new multi-tools **135**.

[0093] The configurations of the already configured multi-tools **135** already exist. The variables  $Assign_{t,s,mt}$  for these multi-tools **135** must be set to the corresponding values in additional constraints.

[0094] If desired, the use of tool stamps **140** of existing multi-tools **135** can be prohibited for types of workpieces **105**, for which they are currently not used. The corresponding  $Process_{c,t,mt}$  variables must then be set to 0.

[0095] Using the following additional target function component the current multi-tools **135** are used in preference ( $w_{small}$  is in this case a small positive real number):

$$-w_{small} \sum_{c \in C} \sum_{mt \in MT} \sum_{t \in T_c} Process_{c,t,mt}$$

? indicates text missing or illegible when filed

[0096] Therefore tools **130** from new multi-tools **135** are not used unnecessarily and the number of the required changes to production programs is kept low.

[0097] Without this target function component it could also happen that for workpieces **105** in which old multi-tools **135** were previously used, no multi-tools **135** are used any longer at all. If, for example, the minimization of the linear magazine changes were the only target function, then for workpieces that require fewer tools **130** than there is available capacity in the linear magazine **120**, the previously used old multi-tools **135** would no longer be used either.

[0098] Although the invention has been illustrated and described in greater detail by means of the preferred exemplary embodiment, the invention is not restricted by the examples disclosed and other variations can be derived therefrom by the person skilled in the art without departing from the scope of protection of the invention.

[0099] For the sake of clarity, it is to be understood that the use of “a” or “an” throughout this application does not exclude a plurality, and “comprising” does not exclude other steps or elements.

1. A method for controlling a machine tool with a first tool magazine and a second tool magazine, wherein a tool for machining a workpiece can be collected from the first tool magazine and a tool can be transferred from the second tool magazine into the first tool magazine, and wherein one of the tools comprises a multi-tool, which is equipped with a plurality of tools prior to the machining, the method:

identifying a plurality of workpieces to be machined;  
determining the tools that are required for machining the identified plurality of workpieces; and  
determining the tools with which the multi-tool is to be fitted;

wherein the tools are determined in such a way that a weighted sum  $l*LC+w*TP$  is minimized over the plurality of workpieces to be machined;

wherein LC is a number of the tools that are transferred from the second tool magazine into the first tool magazine for machining the workpiece;

wherein TP is a number of the tools which are to be fitted in one of the first tool magazine and the second tool magazines for machining the workpiece; and

wherein l and w are predetermined weighting factors.

2. The method as claimed in claim 1, further machining the identified plurality of workpieces by means of the machine tool.

3. The method as claimed in claim 2, wherein a plurality of multi-tools is provided, a plurality of identical tools can be fitted on different multi-tools and the machining of the workpiece which is to be machined with one of the identical tools is performed with only one of the identical tools.

4. The method as claimed in claim 1, wherein a plurality of multi-tools is provided and no two identical tools are fitted in different multi-tools.

5. The method as claimed in claim 1, wherein the tools for the multi-tools are formed using mixed integer programming methods.

6. The method as claimed in claim 1, wherein a quantity of multi-tools with already fitted tools is taken into account.

7. A computer program product, comprising a computer readable hardware storage device having computer readable program code stored therein, said program code executable by a processor of a computer system implement a method as claimed in claim 1.

8. A control device for a machine tool having a tool magazine for tools, of which the machine tool can collect one at a time for machining a workpiece, wherein the control device is configured to carry out the steps of the method of claim 1.

9. A machining system, comprising a machine tool having a tool magazine for tools, of which the machine tool can collect one at a time for machining a workpiece, and a control mechanism as claimed in claim 8.

\* \* \* \* \*