



US 20220132990A1

(19) **United States**

(12) **Patent Application Publication**
Cavaliere

(10) **Pub. No.: US 2022/0132990 A1**

(43) **Pub. Date: May 5, 2022**

(54) **ADJUSTABLE HEEL SUPPORT MEMBER FOR ARTICLE OF FOOTWEAR**

A43B 3/26 (2006.01)

A43B 23/28 (2006.01)

(71) Applicant: **NIKE, Inc.**, Beaverton, OR (US)

A43B 7/24 (2006.01)

(72) Inventor: **Sergio Cavaliere**, Venezia (IT)

A43B 23/14 (2006.01)

(73) Assignee: **NIKE, Inc.**, Beaverton, OR (US)

A43B 23/16 (2006.01)

A43B 7/14 (2006.01)

(21) Appl. No.: **17/577,207**

(52) **U.S. Cl.**

CPC *A43B 21/36* (2013.01); *A43B 23/08*

(2013.01); *A43B 3/26* (2013.01); *A43B 23/28*

(2013.01); *A43B 7/14* (2013.01); *A43B 7/24*

(2013.01); *A43B 23/14* (2013.01); *A43B 23/16*

(2013.01); *A43B 23/088* (2013.01)

(22) Filed: **Jan. 17, 2022**

Related U.S. Application Data

(63) Continuation of application No. 16/745,681, filed on Jan. 17, 2020, now Pat. No. 11,253,027, which is a continuation of application No. 15/719,804, filed on Sep. 29, 2017, now Pat. No. 10,568,386, which is a continuation of application No. 14/803,602, filed on Jul. 20, 2015, now Pat. No. 9,795,187, which is a continuation of application No. 13/023,676, filed on Feb. 9, 2011, now Pat. No. 9,095,188.

(57)

ABSTRACT

An adjustable heel support member includes a base portion and an extended portion. The extended portion comprises a lateral portion, a medial portion and a rearward portion. The heel support member further includes a fastening member that can be used to adjust the lateral portion, the medial portion and the rearward portion to resize the heel support member. In some cases, the fastening member may be an elastic ring.

Publication Classification

(51) **Int. Cl.**

A43B 21/36 (2006.01)

A43B 23/08 (2006.01)

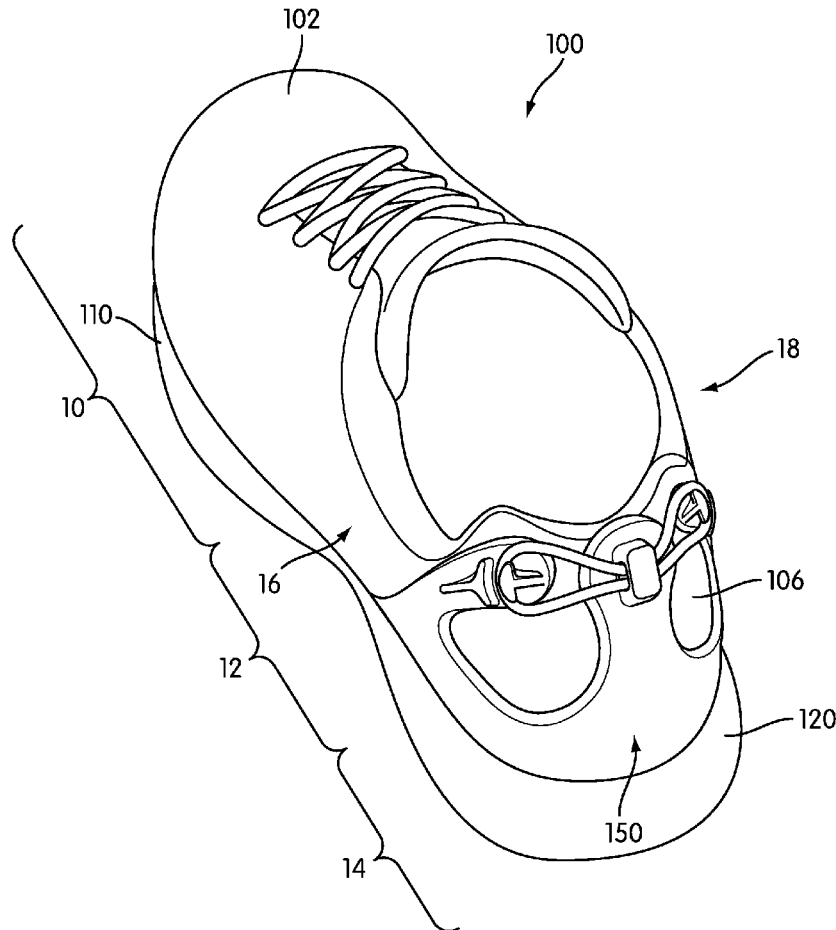

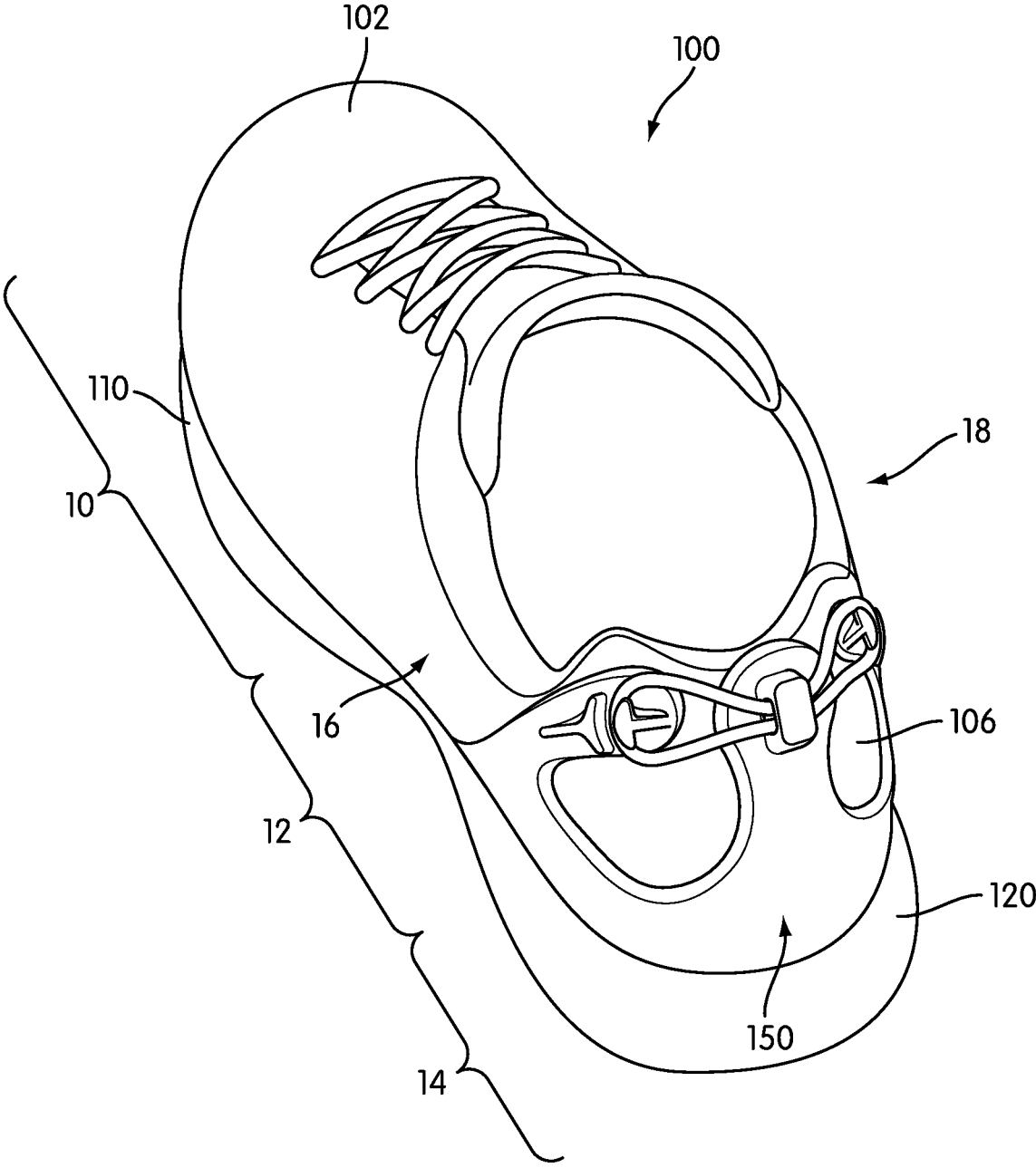

FIG. 1

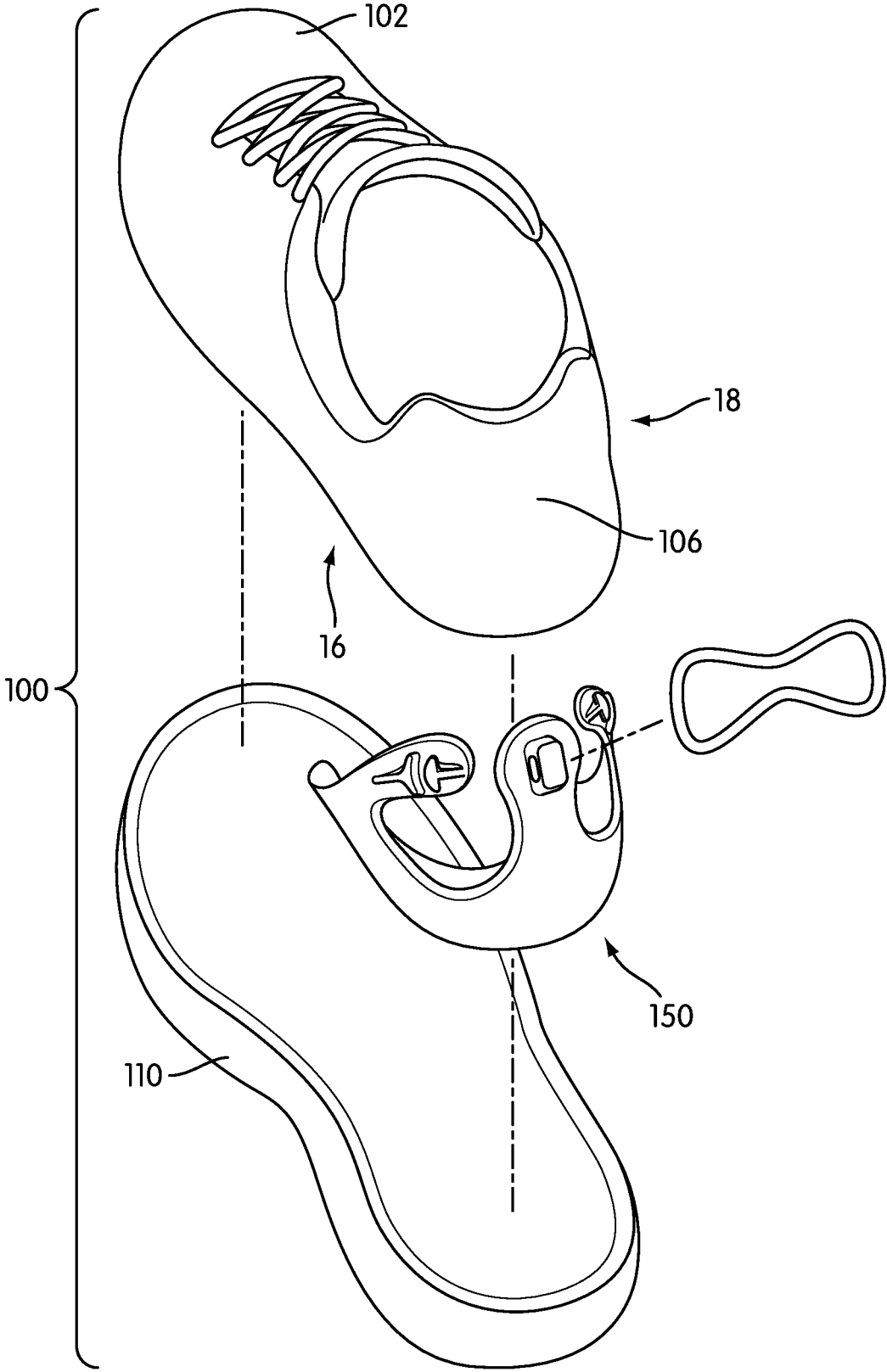

FIG. 2

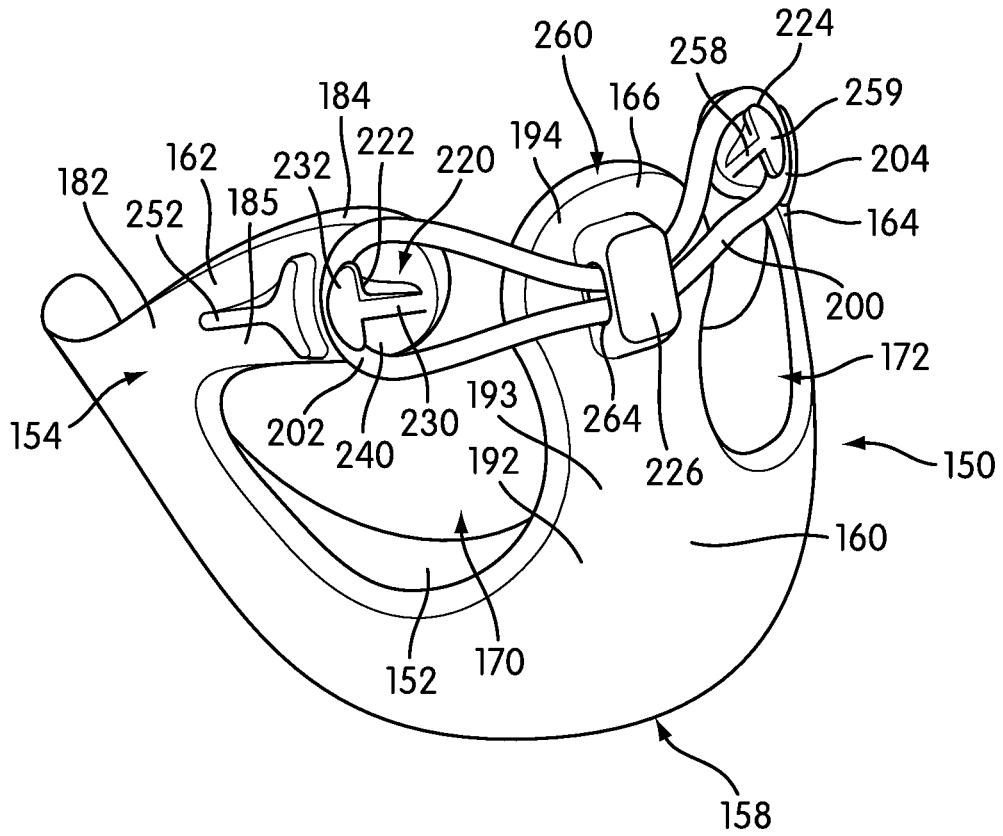

FIG. 3

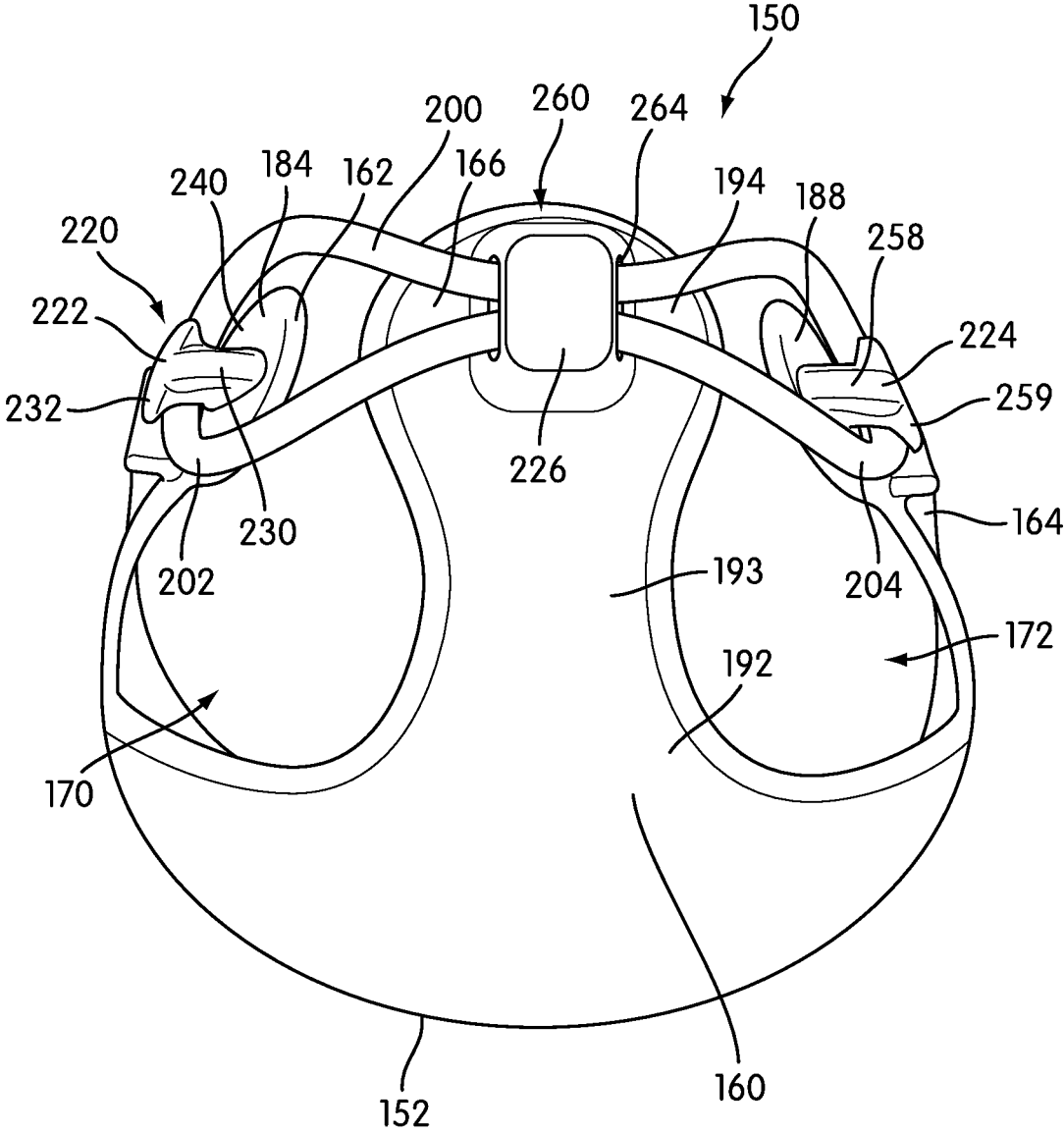

FIG. 4

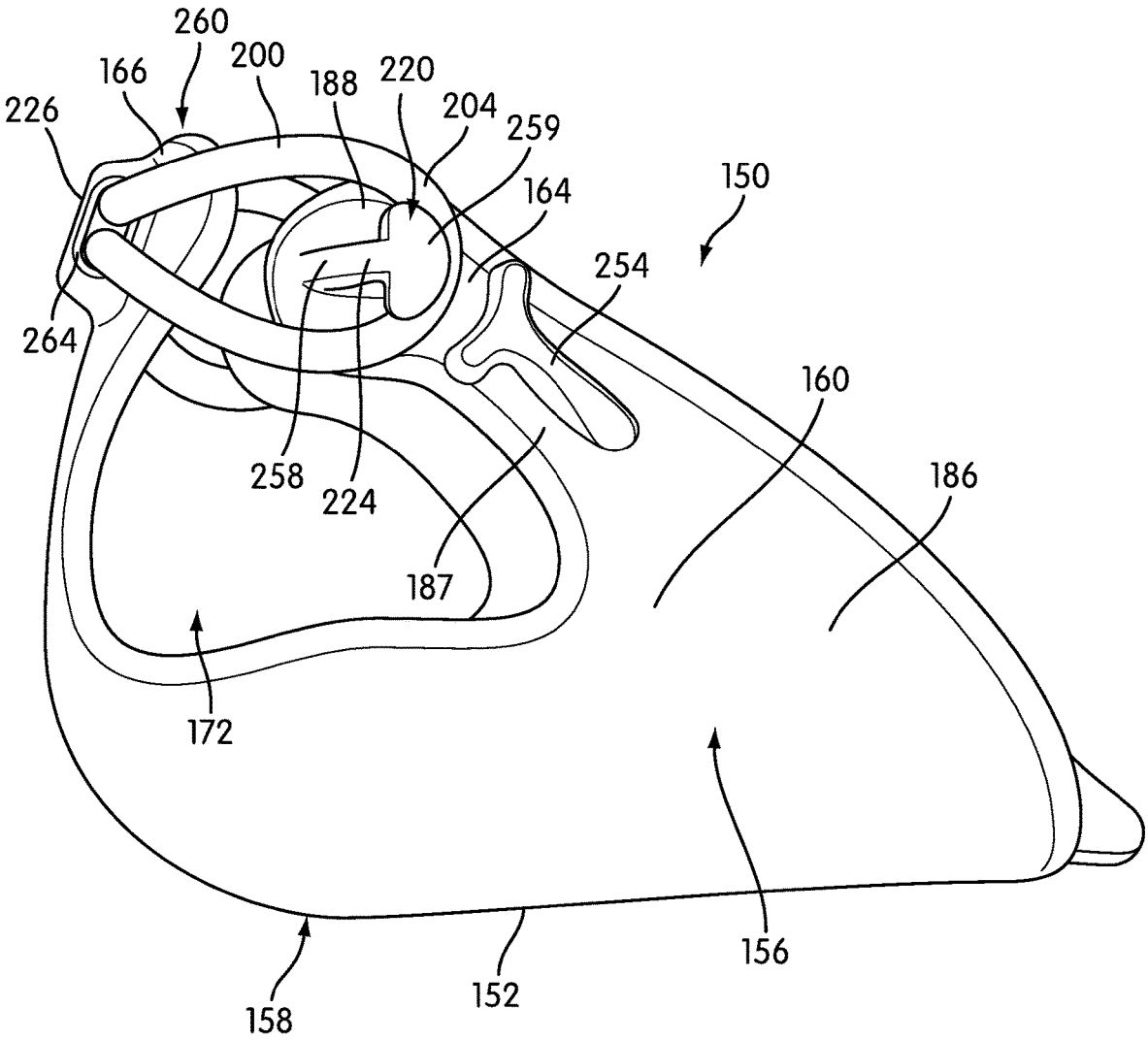

FIG. 5

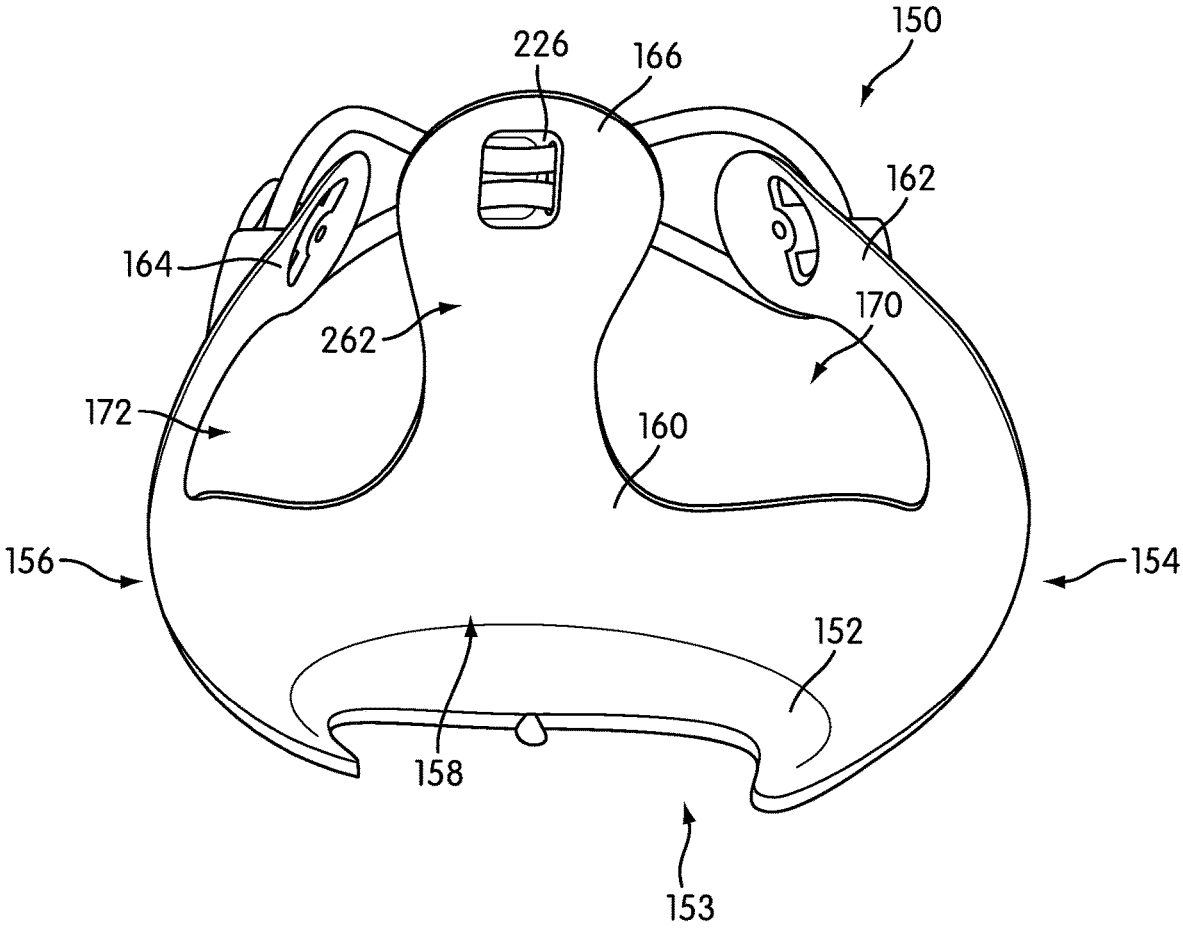

FIG. 6

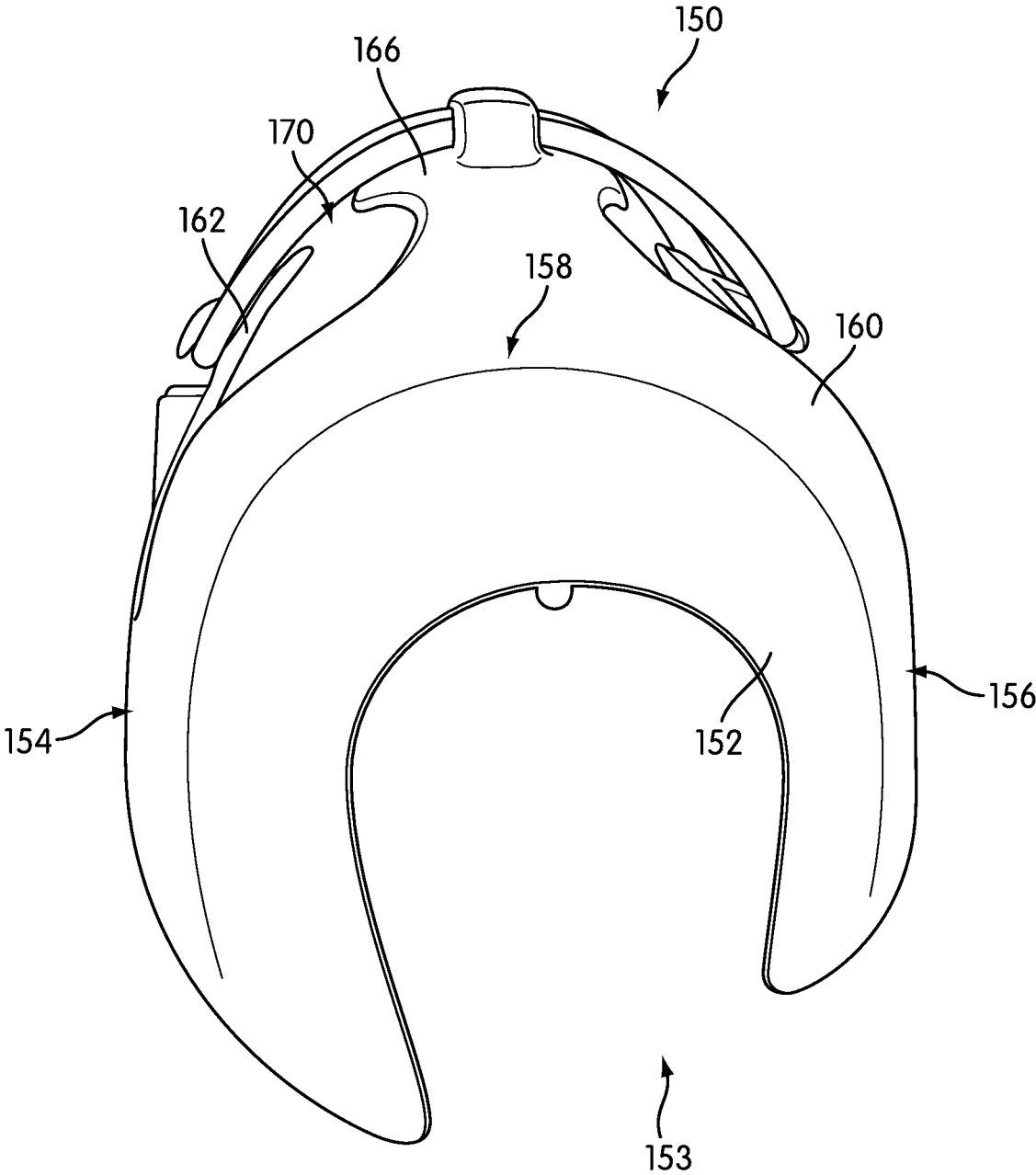

FIG. 7

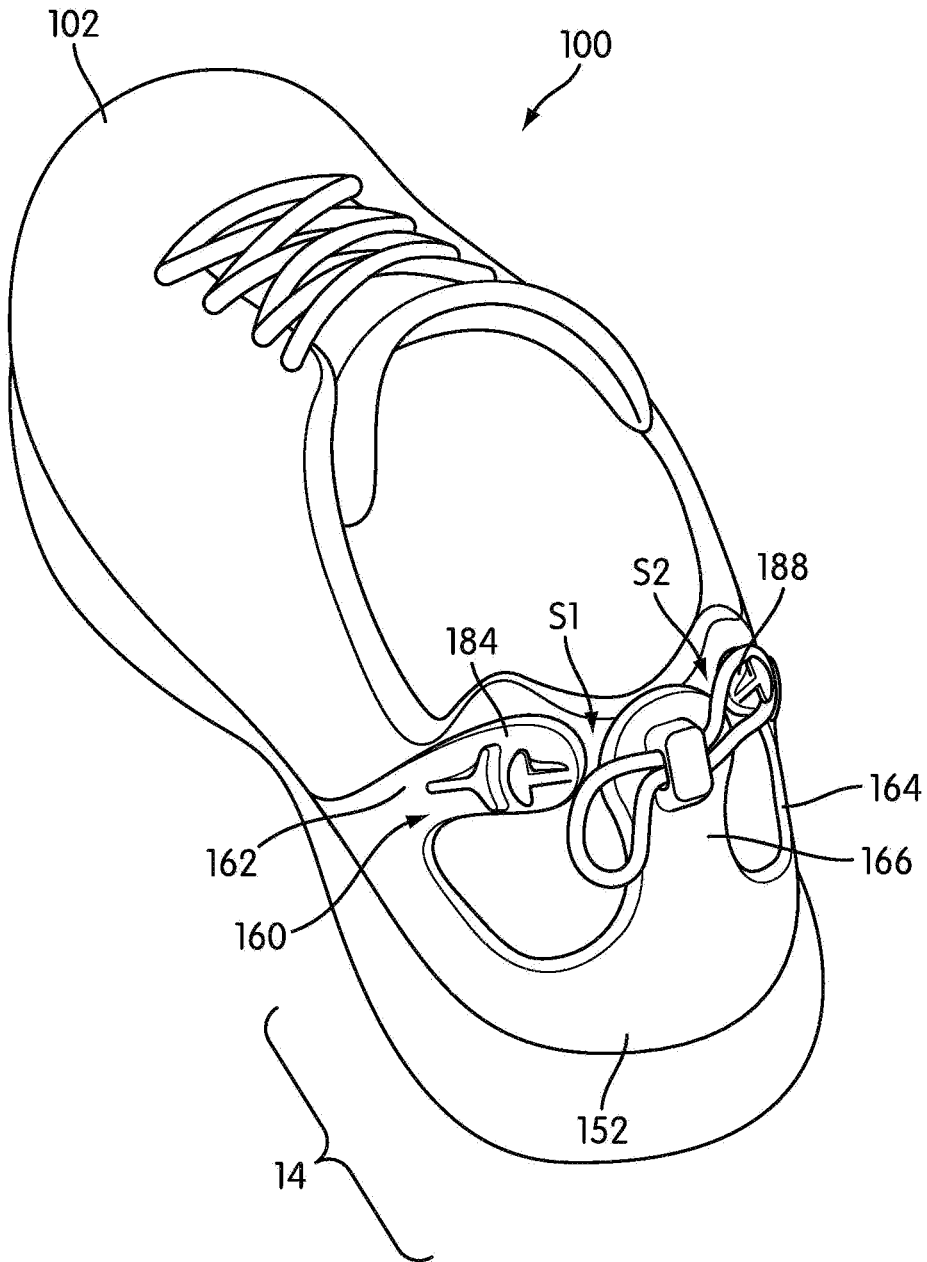

FIG. 8

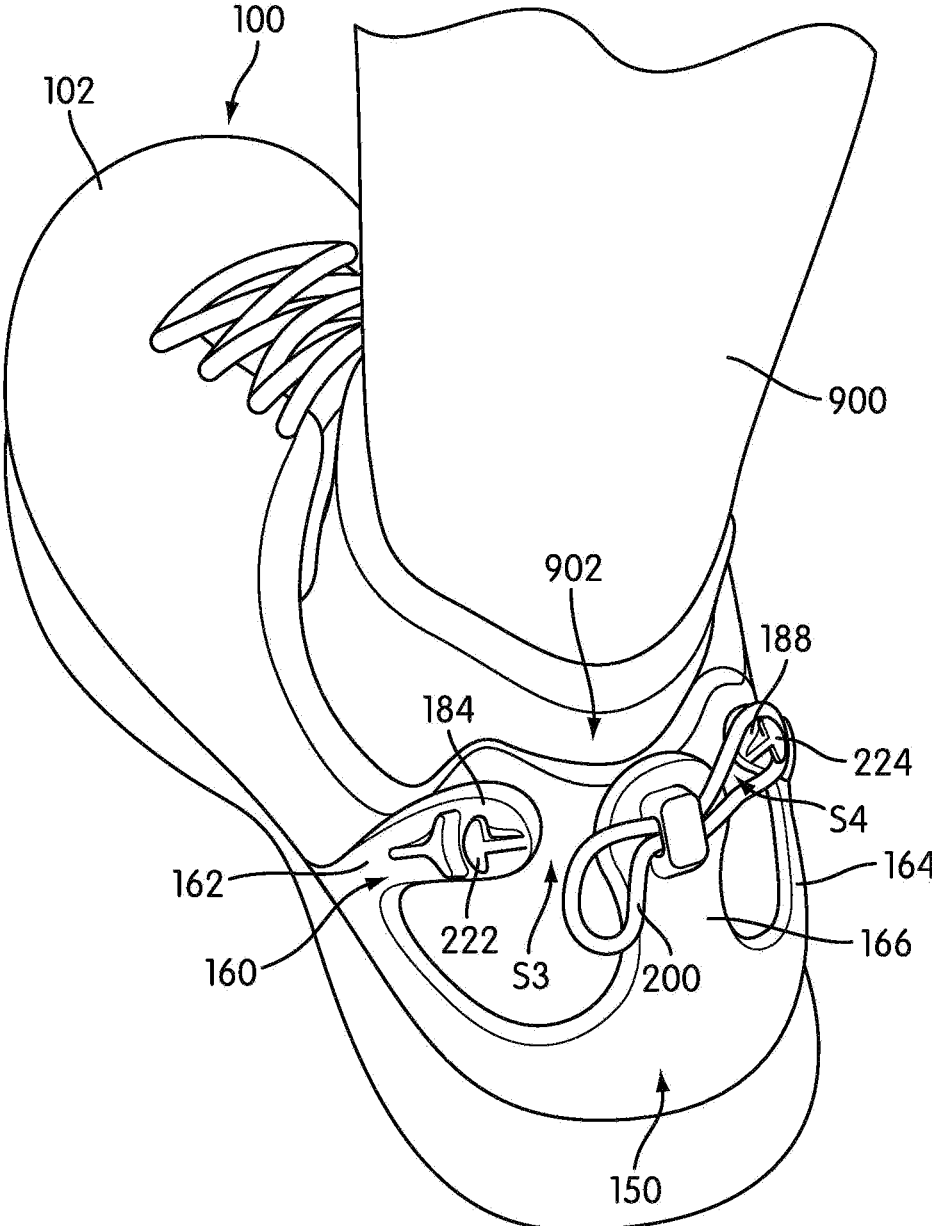

FIG. 9

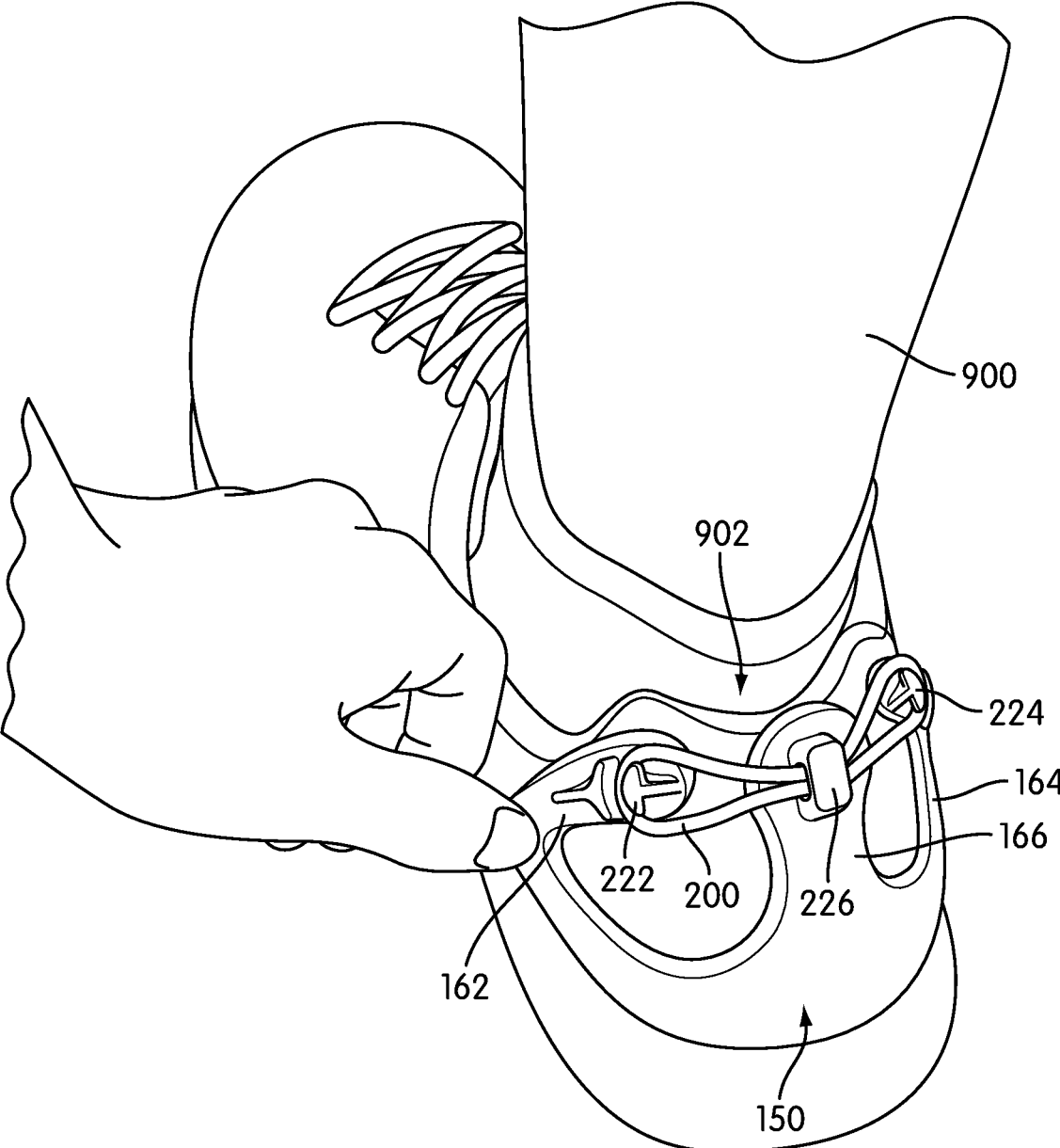

FIG. 10

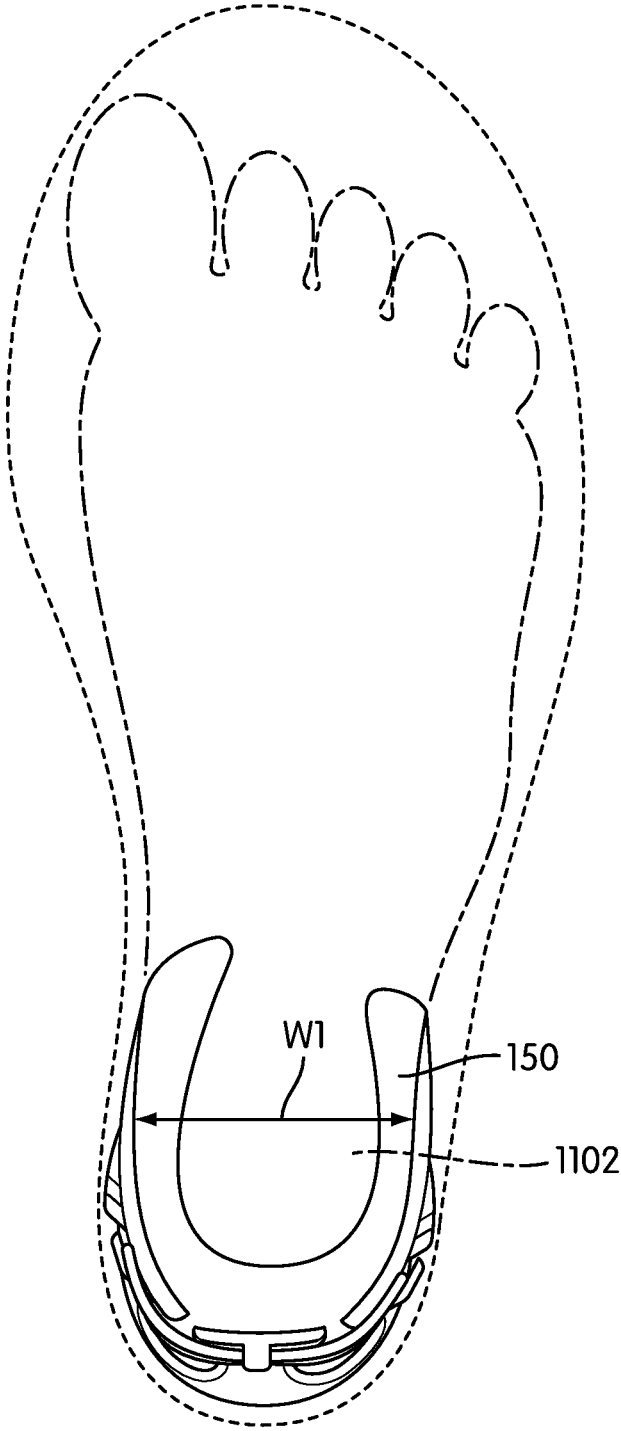

FIG. 11

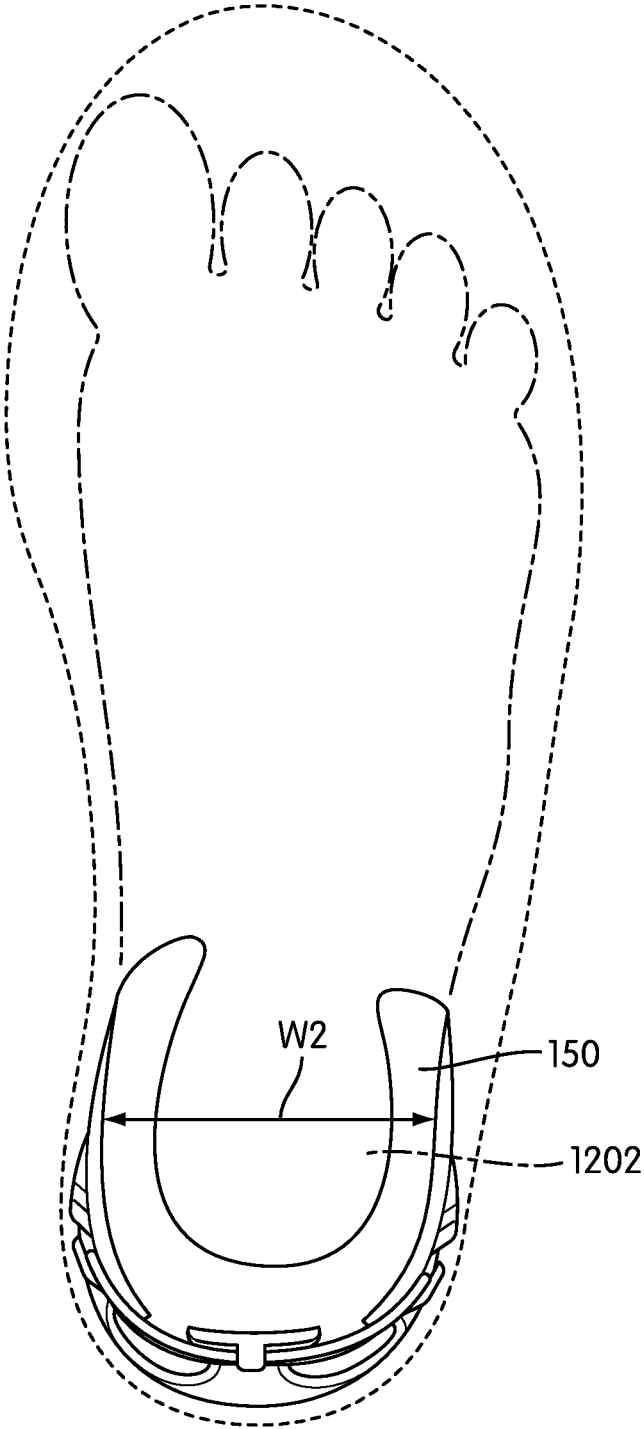

FIG. 12

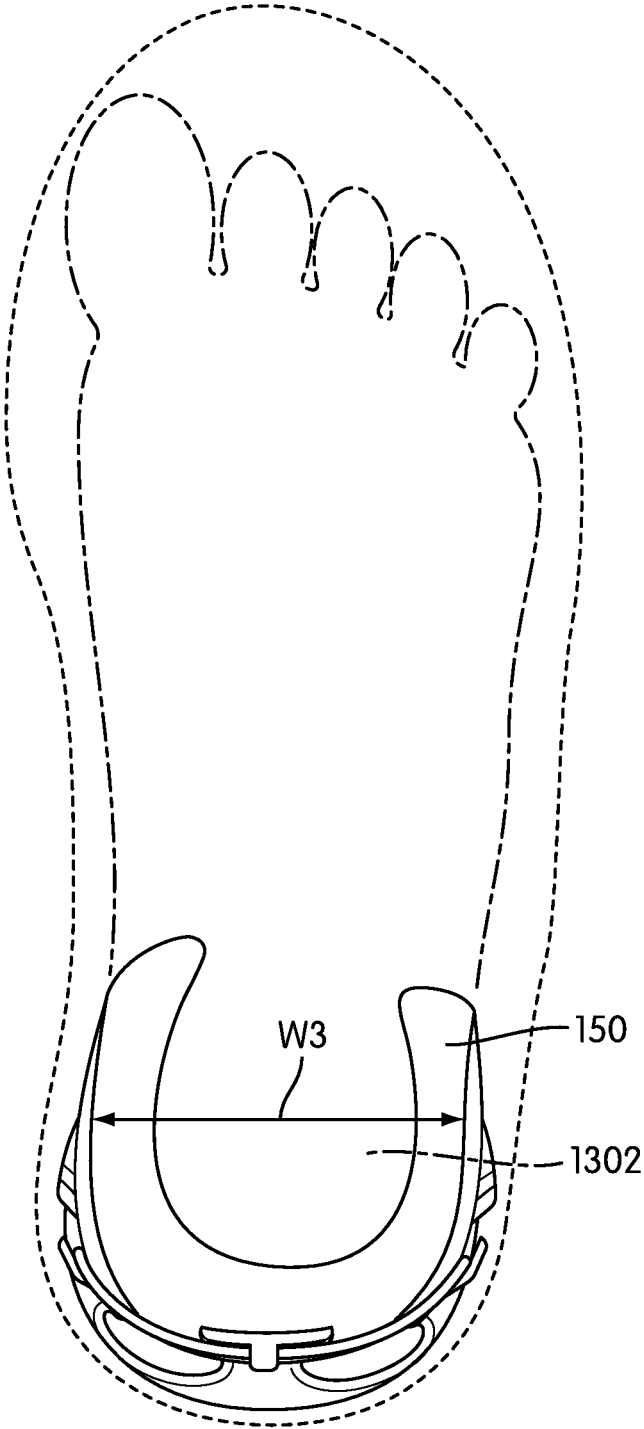

FIG. 13

ADJUSTABLE HEEL SUPPORT MEMBER FOR ARTICLE OF FOOTWEAR

CROSS-REFERENCE TO RELATED APPLICATION

[0001] This is a continuation of U.S. patent application Ser. No. 16/745,681, filed on Jan. 17, 2020, which is a continuation of U.S. patent application Ser. No. 15/719,804, filed on Sep. 29, 2017, now U.S. Pat. No. 10,568,386 issued on Feb. 25, 2020, which is a continuation of U.S. patent application Ser. No. 14/803,602, filed on Jul. 20, 2015, now U.S. Pat. No. 9,795,187 issued on Oct. 24, 2017, which is a continuation of U.S. patent application Ser. No. 13/023,676, filed on Feb. 9, 2011, now U.S. Pat. No. 9,095,188 issued on Aug. 4, 2015, each of which is hereby incorporated by reference in its entirety.

BACKGROUND

[0002] The present embodiments relate generally to an article of footwear, and in particular to an adjustable heel support member for an article of footwear.

SUMMARY

[0003] In one aspect, a heel support member for an article of footwear includes a base portion, a first side portion extending from the base portion, a second side portion extending from the base portion and a rearward portion extending from the base portion. The first side portion is spaced apart from the rearward portion and the second side portion is spaced apart from the rearward portion. A fastening member extends from the first side portion to the second side portion and the fastening member engages the rearward portion and provides tension between the first side portion, the rearward portion and the second side portion.

[0004] In another aspect, a heel support member for an article of footwear includes a first side portion extending from the base portion and a second side portion extending from the base portion, where the second side portion is disposed opposite of the first side portion. The first side portion being spaced apart from the second side portion. A fastening member includes a first portion and a second portion. The first portion is engaged with a first fastener receiving portion on the first side portion and the second portion is engaged with a second fastener receiving portion on the second side portion. The first portion can be disengaged from the first fastener receiving portion.

[0005] In another aspect, a heel support member for an article of footwear includes a base portion, an extended portion extending from the base portion and an elastic ring including a first portion and a second portion. The first portion is attached to a first region of the extended portion and the second portion is attached to a second region of the extended portion. The elastic ring provides an adjustable fit for the heel support member.

[0006] Other systems, methods, features and advantages of the embodiments will be, or will become, apparent to one of ordinary skill in the art upon examination of the following figures and detailed description. It is intended that all such additional systems, methods, features and advantages be included within this description and this summary, be within the scope of the embodiments, and be protected by the following claims.

BRIEF DESCRIPTION OF THE DRAWINGS

[0007] The embodiments can be better understood with reference to the following drawings and description. The components in the figures are not necessarily to scale, emphasis instead being placed upon illustrating the principles of the embodiments. Moreover, in the figures, like reference numerals designate corresponding parts throughout the different views.

[0008] FIG. 1 is a rear isometric view of an embodiment of an article of footwear including an adjustable heel support member;

[0009] FIG. 2 is an exploded isometric view of an embodiment of an article of footwear including an adjustable heel support member;

[0010] FIG. 3 is a rear isometric view of an embodiment of an adjustable heel member;

[0011] FIG. 4 is a rear view of an embodiment of an adjustable heel member;

[0012] FIG. 5 is a side view of an embodiment of an adjustable heel member;

[0013] FIG. 6 is a front view of an embodiment of an adjustable heel member;

[0014] FIG. 7 is a bottom view of an embodiment of an adjustable heel member;

[0015] FIG. 8 is a rear isometric view of an embodiment of an adjustable heel member in an unfastened position;

[0016] FIG. 9 is a rear isometric view of an embodiment of an adjustable heel member after a foot has been inserted;

[0017] FIG. 10 is a rear isometric view of an embodiment of an adjustable heel member fastened around a foot;

[0018] FIG. 11 is a top-down view of an embodiment of an adjustable heel member for a foot with a narrow heel width;

[0019] FIG. 12 is a top-down view of the adjustable heel member of FIG. 11 adjusted to fit a foot with a medium heel width; and

[0020] FIG. 13 is a top-down view of the adjustable heel member of FIG. 11 adjusted to fit a foot with a wide heel width.

DETAILED DESCRIPTION

[0021] FIG. 1 illustrates a rear isometric view of an exemplary embodiment of article of footwear **100**, also referred to simply as article **100**. For clarity, the following detailed description discusses an exemplary embodiment, in the form of a sports shoe, but it should be noted that the present embodiments could take the form of any article of footwear including, but not limited to: hiking boots, soccer shoes, football shoes, sneakers, rugby shoes, basketball shoes, baseball shoes as well as other kinds of shoes. It will be understood that the principles discussed for article of footwear **100** could be used in articles intended for use with a left and/or right foot.

[0022] Referring to FIG. 1, for purposes of reference, article **100** may be divided into forefoot portion **10**, midfoot portion **12** and heel portion **14**. Forefoot portion **10** may be generally associated with the toes and joints connecting the metatarsals with the phalanges. Midfoot portion **12** may be generally associated with the arch of a foot. Likewise, heel portion **14** may be generally associated with the heel of a foot, including the calcaneus bone. In addition, article **100** may include lateral side **16** and medial side **18**. In particular, lateral side **16** and medial side **18** may be opposing sides of

article **100**. Furthermore, both lateral side **16** and medial side **18** may extend through forefoot portion **10**, midfoot portion **12** and heel portion **14**.

[0023] It will be understood that forefoot portion **10**, midfoot portion **12** and heel portion **14** are only intended for purposes of description and are not intended to demarcate precise regions of article **100**. Likewise, lateral side **16** and medial side **18** are intended to represent generally two sides of an article, rather than precisely demarcating article **100** into two halves. In addition, forefoot portion **10**, midfoot portion **12** and heel portion **14**, as well as lateral side **16** and medial side **18**, can also be applied to individual components of an article, such as a sole structure and/or an upper.

[0024] For consistency and convenience, directional adjectives are employed throughout this detailed description corresponding to the illustrated embodiments. The term “longitudinal” as used throughout this detailed description and in the claims refers to a direction extending a length of an article. In some cases, the longitudinal direction may extend from a forefoot portion to a heel portion of the article. Also, the term “lateral” as used throughout this detailed description and in the claims refers to a direction extending a width of an article. In other words, the lateral direction may extend between a medial side and a lateral side of an article. Furthermore, the term “vertical” as used throughout this detailed description and in the claims refers to a direction generally perpendicular to a lateral and longitudinal direction. For example, in cases where an article is planted flat on a ground surface, the vertical direction may extend from the ground surface upward. In addition, the term “proximal” refers to a portion of a footwear component that is closer to a portion of a foot when an article of footwear is worn. Likewise, the term “distal” refers to a portion of a footwear component that is further from a portion of a foot when an article of footwear is worn. It will be understood that each of these directional adjectives may be applied to individual components of an article, such as an upper and/or a sole structure. In some cases, each of these directional adjectives may be applied to a heel counter for an article of footwear, as discussed below.

[0025] Article **100** can include upper **102** and sole structure **110**. Generally, upper **102** may be any type of upper. In particular, upper **102** may have any design, shape, size and/or color. For example, in embodiments where article **100** is a basketball shoe, upper **102** could be a high top upper that is shaped to provide high support for an ankle. In embodiments where article **100** is a running shoe, upper **102** could be a low top upper.

[0026] In some embodiments, sole structure **110** may be configured to provide traction for article **100**. In addition to providing traction, sole structure **110** may attenuate ground reaction forces when compressed between the foot and the ground during walking, running or other ambulatory activities. The configuration of sole structure **110** may vary significantly in different embodiments to include a variety of conventional or non-conventional structures. In some cases, the configuration of sole structure **110** can be configured according to one or more types of ground surfaces on which sole structure **110** may be used. Examples of ground surfaces include, but are not limited to: natural turf, synthetic turf, dirt, as well as other surfaces.

[0027] Sole structure **110** is secured to upper **102** and extends between the foot and the ground when article **100** is worn. In different embodiments, sole structure **110** may

include different components. For example, sole structure **110** may include an outsole, a midsole, and/or an insole. In some cases, one or more of these components may be optional. In an exemplary embodiment, sole structure **110** may include midsole **120**.

[0028] In some cases, midsole **120** may be attached directly to upper **102**. In other cases, midsole **120** may be attached to a sockliner associated with upper **102**. In different embodiments, midsole **120** may have different material characteristics to provide various levels of comfort, cushioning and/or shock absorption. Examples of different materials that could be used for midsole **120** include, but are not limited to: foam, rubber, plastic, polymers, as well as any other kinds of materials.

[0029] In some cases, an outsole may be provided on sole structure **110** to increase traction with a ground surface. Although the current embodiment does not include a separate outsole, other embodiments may include any kind of outsole. An outsole can include one or more tread elements and/or ground penetrating members such as cleats. In some cases, an outsole can have different material characteristics to provide varying levels of traction with a ground surface. Examples of different materials that could be used for an outsole include, but are not limited to: plastic, rubber, polymers, as well as any other kinds of materials that are both durable and wear-resistant.

[0030] An article of footwear can include provisions for supporting the heel of a foot. In some embodiments, an article of footwear can include a heel support member, such as a heel counter. A heel counter may be disposed adjacent to the sides and/or rear of the heel. In some cases, a heel counter helps maintain the foot inside of the article of footwear and can help to reduce over-pronation.

[0031] In some embodiments, article of footwear **100** may include heel support member **150**, also referred to as simply support member **150**. In some cases, heel support member **150** could be a heel counter. In other cases, however, heel support member **150** may be any other kind of support member known in the art for supporting the heel of a foot.

[0032] In different embodiments, heel support member **150** can be associated with different components of article **100**. For example, in some cases, support member **150** may be associated with upper **102**. In other cases, support member **150** may be associated with sole structure **110**. In still other cases, support member **150** could be associated with upper **102** and sole structure **110**.

[0033] FIG. 2 illustrates an exploded isometric view of an embodiment of article **100**. Referring to FIGS. 1 and 2, in some embodiments support member **150** may be configured to wrap around upper **102**, including along lateral portion **16** and medial portion **18** of heel portion **14**. In some cases, support member **150** can also wrap around rearward portion **106** of upper **102**. Furthermore, some portions of support member **150** may extend over a lower portion of upper **102** (not shown) so that some of support member **150** is disposed between upper **102** and sole structure **110**. In embodiments including a sockliner, support member **150** may extend between upper **102** and the sockliner, or between the sockliner and sole structure **110**.

[0034] In different embodiments, support member **150** could be attached to article **100** using a variety of methods. In some cases, for example, support member **150** could be glued, or otherwise bonded to, portions of upper **102** as well as portions of sole structure **110**. In other cases, support

member 150 could be stitched to portions of upper 102 and/or sole structure 110. Moreover, support member 150 could be attached to article 100 before or after the assembly of upper 102 and sole structure 110.

[0035] Although support member 150 is disposed on an outer surface of upper 102 in the current embodiment, and comprises a distinct and separate component from upper 102, other embodiments could include various other configurations. In another embodiment, support member 150 could be integrated into upper 102. For example, support member 150 could be disposed between two layers that comprise upper 102. In another configuration, support member 150 may be attached to an interior surface of upper 102 so that support member 150 is not visible along the outer surface of article 100.

[0036] FIGS. 3 through 7 illustrate various views of heel support member 150. Referring to FIGS. 3 through 7, support member 150 may include base portion 152 and extended portion 160. Base portion 152 comprises a bottom or lower portion for support member 150. In some embodiments, base portion 152 wraps below upper 102 and/or between upper 102 and sole structure 110. In the current embodiment, base portion 152 further includes central gap 153 (see FIGS. 6 and 7) that gives an approximately u-shaped geometry for base portion 152. In other embodiments, however, base portion 152 may not include any gaps. In still other embodiments, base portion 152 could be a substantially solid portion with one or more holes or apertures.

[0037] Extended portion 160 may further comprise various portions such as a first side portion, a second side portion and a rearward portion. In some cases, extended portion 160 includes lateral portion 162 that comprises a first side portion, medial portion 164 that comprises a second side portion and rearward portion 166. Lateral portion 162 extends outwardly from lateral peripheral portion 154 of base portion 152. Likewise, medial portion 164 extends outwardly from medial peripheral portion 156 of base portion 152. In particular, in some cases, lateral portion 162 may be disposed opposite of medial portion 164 with respect to a longitudinal axis of support member 150. Moreover, rearward portion 166 extends outwardly from rearward peripheral portion 158 of base portion 152.

[0038] Generally, the geometry of extended portion 160 can vary. In some cases, each of lateral portion 162, medial portion 164 and/or rearward portion 166 may comprise flap-like portions that are spaced apart by various gaps. Referring to FIG. 3, lateral portion 162 comprises first end portion 182, intermediate portion 185 and a second end portion 184. In some cases, second end portion 184 is substantially wider than intermediate portion 185. Also, as seen in FIG. 5, medial portion 164 comprises first end portion 186, intermediate portion 187 and second end portion 188. In some cases, second end portion 188 is substantially wider than intermediate portion 187. Also, as seen in FIGS. 3 and 4, rearward portion 166 comprises first end portion 192, intermediate portion 193 and second end portion 194, which is substantially wider than intermediate portion 193. These widened end portions may provide additional support near the ankle of the foot.

[0039] Referring again to FIGS. 3 through 7, in one embodiment, lateral portion 162 and rearward portion 166 may be spaced apart by first gap 170. Also, in one embodiment, medial portion 164 and rearward portion 166 may be

spaced apart by second gap 172. Moreover, second end portion 184 of lateral portion 162 may be disposed closer to rearward portion 166 than first end portion 182. Likewise, second end portion 188 of medial portion 164 may be disposed closer to rearward portion 166 than first end portion 186. In other words, both lateral portion 162 and medial portion 164 generally extend partially in a rearward direction. In addition, in some cases, rearward portion 166 extends in a generally vertical, or proximal, direction.

[0040] The current embodiments are only intended to illustrate an exemplary geometry for extended portion 160, including lateral portion 162, medial portion 164 and rearward portion 166. In other embodiments, the geometry of each portion could be varied. Moreover, in other embodiments, extended portion 160 could be divided into more than three portions that are separated by at least three gaps. In still other embodiments, extended portion 160 could be comprised of one portion. In still other embodiments, extended portion 160 could be divided into two portions that are separated by a single gap. For example, in one embodiment, a support member could include a rearward portion and a lateral portion, but not medial portion. As another example, in one embodiment a support member could include a rearward portion and a medial portion, but not a lateral portion. In still another embodiment, a support member could include a lateral portion and a medial portion, but not a rearward portion.

[0041] This exemplary configuration for extended portion 160 allows for lateral portion 162, medial portion 164 and rearward portion 166 to act as flap-like supporting portions that bend with respect to base portion 152. This arrangement allows extended portion 160 to expand and/or contract around the heel of a foot.

[0042] Support member 150 may be further associated with fastening member 200. Fastening member 200 may generally extend between two or more portions of extended portion 160. In some cases, fastening member 200 may extend between lateral portion 162 and rearward portion 166. In some cases, fastening member 200 may extend between medial portion 164 and rearward portion 166. In other cases, fastening member 200 may extend between lateral portion 162 and medial portion 164. In one embodiment, fastening member 200 may extend between lateral portion 162, rearward portion 166 and medial portion 164. In particular, fastening member 200 may extend from lateral portion 162 to rearward portion 166 and from rearward portion 166 to medial portion 164.

[0043] Fastening member 200 could be any provision used for fastening one or more portions of support member 150 around the heel of a foot. In some cases, fastening member 200 could comprise a strip, strap, string, cord or other fastening member having a distinct first end and a second end. In other cases, fastening member 200 could comprise a ring, band or loop-like fastening member. Furthermore, the elasticity properties of fastening member 200 could vary in different embodiments. In some cases, fastening member 200 could have a low elasticity associated with various types of plastic, leather and/or woven straps. In other cases, fastening member 200 could have a high elasticity associated with various types of extendable straps, elastic bands (such as rubber bands) as well as other types of elastic fastening members known in the art. In one embodiment, fastening member 200 comprises a substantially elastic ring.

[0044] Referring now to FIGS. 3 through 5, support member 150 can include provisions for receiving fastening member 200. Support member 150 can include fastener receiving portions 220. Fastener receiving portions 220 include first fastener receiving portion 222 and second fastener receiving portion 224. In particular, first fastener receiving portion 222 is associated with second end portion 184 of lateral portion 162. Likewise, second fastener receiving portion 224 is associated with second end portion 188 of medial portion 164. Although first fastener receiving portion 222 and second fastener receiving portion 224 are disposed on end portions of lateral portion 162 and medial portion 164, respectively, in other embodiments each fastener receiving portion could be disposed on any other portions of lateral portion 162 and/or medial portion 164.

[0045] In different embodiments, the geometry of a fastener receiving portion could vary. In some cases, first fastener receiving portion 222 may have a hook-like geometry that is configured to hold fastening member 200 in place. In one embodiment, first fastener receiving portion 222 includes connecting portion 230 and engaging portion 232. Connecting portion 230 is a relatively narrow portion that extends outwardly from surface 240 of lateral portion 162 and secures engaging portion 232. Engaging portion 232 may be spaced apart from surface 240 of lateral portion 162 so that fastening member 200 can fit between engaging portion 232 and lateral portion 162.

[0046] Engaging portion 232 extends in an approximately perpendicular direction from connecting portion 230. In some cases, for example, engaging portion 232 and connecting portion 230 are configured in a T-like shape. Moreover, first fastener receiving portion 222 may be oriented so that connecting portion 230 is disposed more rearwardly along lateral portion 162 than engaging portion 232. Using this arrangement, fastening member 200 may be pulled in tension against first fastener receiving portion 222 and engaging portion 232 may act to prevent fastening member 200 from sliding off of first fastener receiving portion 222.

[0047] The geometry for first fastener receiving portion 222 shown here is only intended to be exemplary and in other embodiments, other geometries are also possible. It will be understood that second fastener receiving portion 224 could be provided with a substantially similar geometry to first fastener receiving portion 222. For example, second fastener receiving portion 224 may include connecting portion 258 and engaging portion 259 that are configured in a similar arrangement to connecting portion 230 and engaging portion 232. In other embodiments, however, second fastener receiving portion 224 could have any other geometry. For example, in some cases, second fastener receiving portion 224 could be configured as a closed loop that fixes fastening member 200 in place in a semi-permanent manner.

[0048] In some cases, first fastener receiving portion 222 and second fastener receiving portion 224 may be further associated with first raised portion 252 and second raised portion 254, respectively. In some cases, first raised portion 252 and second raised portion 254 may be t-shaped portions that are disposed adjacent to the engaging portions of first fastener receiving portion 222 and second fastener receiving portion 224. In some cases, first raised portion 252 and second raised portion 254 could facilitate aligning fastening member 200 with fastener receiving portions in some embodiments.

[0049] In some embodiments, rearward portion 166 may include third fastener receiving portion 226. In some cases, third fastener receiving portion 226 comprises a raised portion that extends outwardly from outer surface 260 of rearward portion 166. In addition, third fastener receiving portion 226 includes openings 264 for receiving fastening member 200 through opposing sides of third fastener receiving portion 226. As seen in FIG. 6, in some cases, third fastener receiving portion 226 may be substantially hollow and open along inner surface 262 of rearward portion 166.

[0050] Using this configuration discussed above, fastening member 200 may be secured through third fastener receiving portion 226 as well as at first fastener receiving portion 222 and second fastener receiving portion 224. In the current embodiment, for example, first portion 202 of fastening member 200 is engaged with first fastener receiving portion 222. In particular, first portion 202 is held in place by engaging portion 232. Also, second portion 204 of fastening member 200 is engaged with second fastener receiving portion 224. In particular, second portion 204 is held in place by engaging portion 259.

[0051] Referring now to FIG. 8, extended portion 160 generally wraps around heel portion 14 of upper 102. In particular, lateral portion 162, medial portion 164 and rearward portion 166 may generally wrap around lateral side 16, medial side 18 and rearward portion 166, respectively. Additionally, portions of base portion 152 may be disposed beneath upper 102 at heel portion 14. This configuration may provide stability and support for a heel disposed inside upper 102.

[0052] In the unfastened position shown in FIG. 8, each of lateral portion 162, medial portion 164 and rearward portion 166 may rest against upper 102. Moreover, in this case, second end portion 184 of lateral portion 162 is spaced apart from rearward portion 166 by spacing S1. Similarly, second end portion 188 of medial portion 164 is spaced apart from rearward portion 166 by spacing S2.

[0053] Referring now to FIG. 9, foot 900 has been inserted into article 100. As foot 900 is inserted, extended portion 160 flexes to accommodate the width of heel 902 of foot 900. In particular, lateral portion 162 and medial portion 164 are flexed away from rearward portion 166. In this stretched position, second end portion 184 of lateral portion 162 is spaced apart from rearward portion 166 by spacing S3 that is substantially larger than the original spacing S1 shown in FIG. 8. Likewise, second end portion 188 of medial portion 164 is spaced apart from rearward portion 166 by spacing S4 that is substantially larger than the original spacing S2 shown in FIG. 8. In other words, the size of support member 150 may generally change to accommodate the width of a user's foot.

[0054] Initially, before support member 150 is tightened, fastening member 200 may only be fastened at second fastener receiving portion 224, but not first fastener receiving portion 222. Referring to FIG. 10, in order to tighten support member 150 around heel 902, a user may pull fastening member 200 over first fastener receiving portion 222, so that fastening member 200 is pulled taut from medial portion 164 to lateral portion 162 and across rearward portion 166. As fastening member 200 is tightened, lateral portion 162, medial portion 164 and rearward portion 166 are pulled inwardly to provide a better fit and increased support for heel 902. This can help retain heel 902 in article 100 and can help reduce the occurrence of over-pronation.

[0055] In some cases, to facilitate ease of removing foot 900 from article 100, fastening member 200 can be disengaged from either first fastener receiving portion 222 or second fastener receiving portion 224. In some cases, fastening member 200 may be disengaged from both first fastener receiving portion 222 and second fastener receiving portion 224. In the case where fastening member 200 is disengaged from both receiving portions, fastening member 200 may still be secured to support member 150 through its engagement within third fastener receiving portion 226.

[0056] In some embodiments, fastening member 200 could be permanently attached to either lateral portion 162 and/or medial portion 164. In cases where fastening member 200 is permanently attached to both lateral portion 162 and medial portion 164, fastening member 200 may expand as a heel is inserted into upper 102. In such cases, fastening member 200 need not be engaged and disengaged to fasten support member 150 around the heel.

[0057] The configurations discussed above provide a support member that may serve as a heel counter in an article of footwear. Moreover, the support member is configured to accommodate heels of different sizes, including different widths. This allows a manufacturer to utilize a single heel counter for a variety of different heel widths, rather than making a single heel counter for each heel width. Furthermore, this design accommodates intermediate heel widths that would otherwise not be accommodated, since the support member can adjust to width or size within a given range of sizes.

[0058] FIGS. 11 through 13 illustrate schematic views of support member 150 configured to accommodate a range of different heel widths. Referring to FIGS. 11 through 13, support member 150 is capable of expanding to fit different heel widths of width W1, width W2 and width W3. In particular, in a first fastened position shown in FIG. 11, support member 150 accommodates a relatively narrow width W1 associated with heel 1102. In the fastened position shown in FIG. 12, support member 150 accommodates a medium width W2 associated with heel 1202. In the fastened position shown in FIG. 13, support member 150 accommodates a wide width W3 associated with heel 1302.

[0059] Support member 150 can be made from a variety of different materials. Examples of different materials that could be used for one or more portions of support member 150 include, but are not limited to: plastic, natural leather, synthetic leather, rubber, plastic, woven materials, foams, as well as any other materials known in the art. Moreover, in some other embodiments, different portions of support member 150 could be made of different materials. Fastening member 200 can also be made from a variety of different materials. Examples of different material that could be used for fastening member 200 include, but are not limited to: elastic materials, rubber, woven materials as well as any other materials.

[0060] While various embodiments have been described, the description is intended to be exemplary, rather than limiting and it will be apparent to those of ordinary skill in the art that many more embodiments and implementations are possible that are within the scope of the embodiments. Accordingly, the embodiments are not to be restricted except in light of the attached claims and their equivalents. Also, various modifications and changes may be made within the scope of the attached claims.

What is claimed is:

1. A heel closure apparatus for an article of footwear, comprising:
 - a heel cup comprising a side lobe and a central lobe;
 - a fastener receiving portion disposed at a distal end of the side lobe;
 - a guard disposed proximate the fastener receiving portion; wherein the fastener receiving portion is configured to capture and retain a fastener;
 - wherein the guard defines a first ramp portion and a cross-bar coupled to the first ramp portion;
 - wherein the fastener receiving portion includes a second ramp portion that connects an anterior edge of the fastener receiving portion to an outward-facing surface of the side lobe; and
 - wherein a ramp height of the second ramp portion of the fastener receiving portion is greatest proximate the anterior edge of the fastener receiving portion.
2. The heel closure apparatus of claim 1, wherein the guard is spaced apart from the fastener receiving portion.
3. The heel closure apparatus of claim 1, wherein the fastener receiving portion is a medial fastener receiving portion, the side lobe is a medial lobe, the heel cup further comprises a lateral lobe, the heel closure apparatus further comprises a lateral fastener receiving portion disposed at a distal end of the lateral lobe of the heel cup, and the medial fastener receiving portion and the lateral fastener receiving portion are mirror images of each other, the heel closure apparatus further comprises a central fastener receiving portion disposed at a distal end of the central lobe, and the central fastener receiving portion defines at least one guide channel sized to receive the fastener.
4. The heel closure apparatus of claim 3, wherein:
 - a medial portion of the fastener extends outwardly from the at least one guide channel and toward the medial lobe; and
 - a lateral portion of the fastener extends outwardly from the at least one guide channel and toward the lateral lobe.
5. The heel closure apparatus of claim 4, wherein each of the medial fastener receiving portion and the lateral fastener receiving portion extends away from an exterior surface of a respective one of the medial lobe and the lateral lobe so that an engaging surface of each of the medial fastener receiving portion and the lateral fastener receiving portion faces away from the central fastener receiving portion.
6. The heel closure apparatus of claim 4, wherein at least one of the medial fastener receiving portion and the lateral fastener receiving portion includes a broadened flange proximate the anterior edge of the at least one of the medial fastener receiving portion or the lateral fastener receiving portion, and wherein one or more portions of the broadened flange overlap a portion of the fastener when the fastener is engaged with the at least one of the medial fastener receiving portion and the lateral fastener receiving portion.
7. The heel closure apparatus of claim 6, wherein the second ramp portion extends towards a gap disposed between the corresponding one of the medial lobe or the lateral lobe and the central lobe.
8. The heel closure apparatus of claim 7, wherein the ramp height of the second ramp portion of the at least one of the medial fastener receiving portion or the lateral fastener receiving portion is lowest proximate the gap.

9. The heel closure apparatus of claim 4, wherein the fastener includes an elastic cord that is configured to be placed under tension when the medial portion is engaged with the medial fastener receiving portion and the lateral portion is engaged with the lateral fastener receiving portion.

10. The heel closure apparatus of claim 4, wherein the fastener receiving portion is disposed on an outward-facing surface of the central lobe.

11. The heel closure apparatus of claim 4, wherein the guard is a raised portion, the central fastener receiving portion includes a central fastener receiving body, the central fastener receiving portion defines the at least one guide channel extending through the central fastener receiving body from a medial side of the central fastener receiving portion to a lateral side of the central fastener receiving portion, and the at least one guide channel is sized to receive the fastener.

12. The heel closure apparatus of claim 11, wherein the fastener includes an elastic cord, and the guard is spaced apart from the corresponding one of the medial fastener receiving portion or the lateral fastener receiving portion by a distance that is equal to or greater than a cross-sectional diameter of the elastic cord.

13. The heel closure apparatus of claim 4, wherein the guard is disposed proximate and spaced apart from an engaging surface of a corresponding one of the medial fastener receiving portion or the lateral fastener receiving portion, and wherein the guard is configured to facilitate aligning the fastener with the engaging surface of the corresponding one of the medial fastener receiving portion or the lateral fastener receiving portion.

14. An article of footwear, comprising:

an upper;

a sole structure coupled to the upper;

a heel cup including:

a base portion disposed between the upper and the sole structure such that the base portion is sandwiched between the upper and the sole structure;

a side lobe extending from the base portion, wherein the side lobe is at a heel portion of the article of footwear;

a central lobe extending from the base portion;

a fastener receiving portion disposed at a distal end of the side lobe;

a guard disposed proximate the fastener receiving portion;

wherein the fastener receiving portion is configured to capture and retain a fastener;

wherein the guard defines a first ramp portion and a cross-bar coupled to the first ramp portion;

wherein the fastener receiving portion includes a second ramp portion that connects an anterior edge of the fastener receiving portion to an outward-facing surface of the side lobe; and

wherein a ramp height of the second ramp portion of the fastener receiving portion is greatest proximate the anterior edge of the fastener receiving portion.

15. The article of footwear of claim 14, wherein the guard is spaced apart from the fastener receiving portion.

16. The article of footwear of claim 14, wherein the fastener receiving portion is a medial fastener receiving portion, the side lobe is a medial lobe, the heel cup further comprises a lateral lobe extending from the base portion, the heel cup further comprises a lateral fastener receiving portion coupled to the lateral lobe, the medial fastener receiving portion and the lateral fastener receiving portion are mirror images of each other, and the lateral fastener receiving portion captures the fastener.

17. The article of footwear of claim 16, wherein the medial lobe is spaced apart from the central lobe by a medial gap, the heel cup further comprises a central fastener receiving portion disposed at a distal end of the central lobe, the central fastener receiving portion includes a central fastener receiving body, the central fastener receiving body defines at least one guide channel extending through the central fastener receiving body from a medial side of the central fastener receiving portion to a lateral side of the central fastener receiving portion, and the at least one guide channel receives the fastener.

18. The article of footwear of claim 17, wherein the lateral lobe is spaced apart from the central lobe by a lateral gap, and the base portion defines a central gap such that the base portion has a U-shape geometry.

19. The article of footwear of claim 14, wherein the heel cup is a distinct and separate component from the upper.

20. The article of footwear of claim 19, wherein the heel cup is a distinct and separate component from the sole structure.

* * * * *