



(12) **EUROPEAN PATENT SPECIFICATION**

(45) Date of publication and mention
of the grant of the patent:
16.01.2002 Bulletin 2002/03

(21) Application number: **96916304.7**

(22) Date of filing: **05.06.1996**

(51) Int Cl.7: **F04B 27/08, F04B 39/00**

(86) International application number:
PCT/JP96/01510

(87) International publication number:
WO 96/39581 (12.12.1996 Gazette 1996/54)

(54) **PISTON-TYPE COMPRESSOR**
KOLBENVERDICHTER
COMPRESSEUR DU TYPE A PISTON

(84) Designated Contracting States:
DE FR GB IT

(30) Priority: **05.06.1995 JP 13824195**

(43) Date of publication of application:
13.08.1997 Bulletin 1997/33

(73) Proprietor: **Kabushiki Kaisha Toyota Jidoshokki**
Kariya-shi, Aichi-ken (JP)

(72) Inventors:
• **TAKENAKA, Kenji,**
K.K.Toyoda Jidoshokki Seisakusho
Kariya-shi, Aichi-ken 448 (JP)
• **KAYUKAWA, Hiroaki, K.K.Toyoda Jidoshokki**
Seisakusho
Kariya-shi, Aichi-ken 448 (JP)
• **HAMAOKA, Takahiro, K.K.Toyoda Jidoshokki**
Seisakusho
Kariya-shi, Aichi-ken 448 (JP)

• **MICHYUKI, Takashi**
Anjo-shi, Aichi-ken 446 (JP)
• **HASHIMOTO, Mitsuru, K.K.Toyoda Jidoshokki**
Seisakusho
Kariya-shi, Aichi-ken 448 (JP)
• **KAWAGUCHI, Masahiro, K.K.Toyoda Jidoshokki**
Seisakusho
Kariya-shi, Aichi-ken 448 (JP)

(74) Representative: **Vollnhals, Aurel, Dipl.-Ing.**
Patentanwälte Tiedtke-Bühling-Kinne & Partner
Bavariaring 4
80336 München (DE)

(56) References cited:
DE-A- 4 112 704 **DE-A- 4 207 186**
FR-A- 2 392 253 **JP-B- 37 007 540**
JP-U- 4 109 481 **JP-U- 48 045 209**
JP-U- 53 038 014 **JP-Y- 1 011 985**
JP-Y- 43 018 930 **US-A- 3 061 175**
US-A- 5 382 139

Description

SPECIFICATION

TECHNICAL FIELD

[0001] The present invention relates to a piston type compressor according to the preamble of claim 1.

BACKGROUND ART

[0002] Compressors are used to air-condition passenger compartments in vehicles. Piston type compressors are typically used for such compressors. The piston type compressor has a driving body, such as a swash plate, for a reciprocating piston. The driving body is supported by a rotary shaft in a crank chamber and converts the rotation of the rotary shaft to the linear reciprocating movement of the piston in a cylinder bore. The reciprocating movement of the pistons draws refrigerant gas into the cylinder bore from a suction chamber, compresses the gas in the cylinder bore, and discharges the gas into a discharge chamber.

[0003] The typical piston type compressor draws the refrigerant gas from an external refrigerant circuit into a suction chamber by way of the crank chamber. In such a compressor, in which the crank chamber constitutes a portion of a refrigerant gas passage, the refrigerant gas passing through the crank chamber sufficiently lubricates various parts in the crank chamber, such as the piston and the driving body, with the lubricating oil suspended in the gas.

[0004] There is also a type of compressor that draws in refrigerant gas from an external refrigerant circuit without having the gas flow through its crank chamber. Japanese Unexamined Patent Publication 60-175783 discloses such a compressor. In such a compressor, in which the crank chamber does not constitute a portion of the refrigerant gas passage, the various parts in the crank chamber are lubricated mainly by lubricating oil that is included in blowby gas. Blowby gas refers to the refrigerant gas in the cylinder bore that leaks into the crank chamber through the space defined between the outer circumferential surface of the piston and the inner circumferential surface of the cylinder bore when the piston compresses the refrigerant gas in the cylinder bore.

[0005] The amount of blowby gas, or lubricating oil, supplied into the crank chamber is determined by the dimension of the clearance defined between the outer circumferential surface of the piston and the inner circumferential surface of the cylinder bore. Accordingly, it is necessary to increase the dimension of the clearance to supply a sufficient amount of lubricating oil to satisfactorily lubricate the various parts in the crank chamber. However, a large clearance between the piston and the cylinder bore degrades the compressing efficiency of the compressor.

[0006] To cope with this problem, compressors having a structure such as that shown in Figs. 22 and 23 are known in the prior art. The compressor shown in Fig. 22 has a swash plate 124, which serves as a driving body and which is mounted on a rotary shaft (not shown) so as to rotate integrally with the shaft. Shoes 125 are arranged between the swash plate 124 and the rear portion of a single-headed piston 122. Each shoe 125 has a spheric surface, which is slidably engaged with a retaining recess 122a of the piston 122, and a flat surface, which slides on the front or rear surface of the swash plate 124. When the rotary shaft and the swash plate 124 rotate integrally, the swash plate 124 serves to reciprocate the piston 122 in a cylinder bore 123 by means of the shoes 125.

[0007] The compressor shown in Fig. 23 has a wobble plate 128, which is mounted on a rotary shaft (not shown) and which rotates relatively with respect to the shaft. Rotation of the rotary shaft causes oscillating movement of the wobble plate 128. A rod 129 has a spheric body 129a formed on both of its ends. Each spheric body 129a is slidably held in either a retaining recess 128a of the wobble plate 128 or a retaining recess 126a of a piston 126. Rotation of the rotary shaft oscillates the wobble plate 128. The oscillation is transmitted to the piston 126 through the rod 129 and reciprocates the piston 126 in a cylinder bore 127.

[0008] In the above compressors, an annular groove 121 is defined in the outer circumferential surface of each piston 122, 126. Lubricating oil, adhered to the inner circumferential surfaces of the cylinder bores 123, 127, collects in the grooves 121 as the pistons 122, 126 are reciprocated. The grooves 121 are exposed to the inside of the crank chamber as they extend from the cylinder bores 123, 127 when the pistons 122, 126 move to the bottom dead center position. Accordingly, the lubricating oil collected in the grooves 121 is discharged toward the swash plate 124 and the wobble plate 128 (i.e., the crank chamber) when the grooves 121 are outside of the cylinder bores 123, 127. The coupling between the swash plate 124 and the wobble plate 128, the associated piston 122, 126, and other parts are lubricated by the lubricating oil. Thus, in compressors having such a structure, the various parts in the crank chamber may be satisfactorily lubricated without enlarging the dimension of the clearance between the pistons 122, 126 and the respective cylinder bores 123, 127, or without reducing the compressing efficiency of the compressor.

[0009] However, the compressors shown in Fig. 22 and 23 also have the following disadvantages.

[0010] As the pistons 122, 126 approach the bottom dead center, the length of the pistons 122, 126 remaining in the associated cylinder bores 123, 127 becomes small. The pistons 122, 126 reciprocate within the associated bores 123, 127 in a manner such that they are supported by the inner circumferential surfaces of the cylinder bores 123, 127. As a result, when the length of

the pistons 122, 126 accommodated in the associated bores 123, 127 is small, that is, when the portion of the pistons 22, 26 supported by the associated bores 123, 127, becomes small, the support by the bores 123, 127 is unstable and causes a loose fit. As shown exaggerated in Figs. 22 and 23, this leads to interference between the edges of the grooves 121 in the pistons 122, 126 and the edges of the associated bores 123, 127. This not only hinders smooth reciprocation of the pistons 122, 126 but may also cause abrasive wear and damage of the edges of the grooves 121 in the pistons 122, 126 and the edges of the associated bores 123, 127.

[0011] In the compressor shown in Fig. 22, the rotating movement of the swash plate 124 is converted to the reciprocating movement of the piston 122 by means of the shoes 125. The compression reaction and inertial force of the piston 122 act on the swash plate 124 through the piston 122 when, for example, the piston 122 moves toward the top dead center from the bottom dead center to compress refrigerant gas. The force of the swash plate 124 acts on the piston 122 as a reaction force, and a portion of the reaction force acting on the piston 122 is applied in a direction in which the piston 122 presses the inner circumferential surface of the bore 123 due to the swash plate 124 being inclined with respect to a plane perpendicular to the axis of the rotary shaft. Thus, in the compressor shown in Fig. 22, the groove 121 of the piston 122 hits the edge of the cylinder bore 123 with a stronger impact and causes the problem of abrasive wear and damage to become further prominent in comparison with the compressor shown in Fig. 23.

[0012] From document DE-A-42 07 186 a piston type compressor is known comprising a swash plate mounted on a rotary shaft in a crank chamber and a piston accommodated in a cylinder bore. The piston is coupled to the swash plate through a shoe when the swash plate converts rotation of the rotary shaft to reciprocation of the piston between a top dead center and a bottom dead center. This piston has an outer circumferential surface that slides against an inner circumferential surface of the cylinder bore, wherein the outer circumferential surface is provided with a groove to improve the lubrication of the piston.

[0013] The object of the present invention is to provide a piston type compressor that is capable of moving pistons smoothly while also supplying a sufficient amount of lubricating oil to members which drive the pistons.

DISCLOSURE OF THE INVENTION

[0014] This object is solved by the features of claim 1. According to the present invention, the piston reciprocates between a top dead center and a bottom dead center in a cylinder bore by means of a driving body mounted on a rotary shaft in a crank chamber during the rotation of the rotary shaft. The piston has an outer circumferential surface that slides against an inner circum-

ferential surface of the cylinder bore. The outer circumferential surface of the piston is provided with a groove extending in the direction of the axis of the piston.

[0015] Accordingly, during reciprocation of the piston, lubricating oil adhered to the inner circumferential surface of the cylinder bore collects in the groove. When the groove is exposed to the inside of the crank chamber from the cylinder bore during the reciprocation of the piston, the lubricating oil in the groove is supplied to the inside of the crank chamber. The lubricating oil lubricates the driving body and other parts in the crank chamber. The piston moves smoothly since the groove extending in the axial direction of the piston does not interfere with the edge of the cylinder bore. The groove also decreases the sliding resistance between the piston and the cylinder bore.

BRIEF DESCRIPTION OF THE DRAWINGS

[0016]

Fig. 1 is a cross-sectional view showing a first embodiment of a compressor according to the present invention;

Fig. 2 is a perspective view showing a piston located at the top dead center;

Fig. 3 is a perspective view showing the piston located between the top dead center and the bottom dead center;

Fig. 4 is a perspective view showing the piston located at the bottom dead center;

Fig. 5 is a partial enlarged cross-sectional view showing the piston;

Fig. 6(a) is a graph showing the relationship between the rotational angle of the rotary shaft (location of the piston) and the level of the side force acting on the piston;

Fig. 6(b) is a schematic drawing showing the optimal position for providing a second groove;

Fig. 7 is an enlarged cross-sectional view showing the inclination of the piston located at the top dead center position in an exaggerated manner;

Fig. 8 is a perspective view showing a piston according to a first modification;

Fig. 9 is a perspective view showing a piston according to a second modification;

Fig. 10 is a perspective view showing a piston according to a third modification;

Fig. 11(a) is a perspective view showing a piston according to a fourth modification;

Fig. 11(b) is a perspective view showing a piston according to a fifth modification;

Fig. 11(c) is a perspective view showing a piston according to a sixth modification;

Fig. 12 is a cross-sectional view showing a second embodiment of a compressor according to the present invention;

Fig. 13 is a cross-sectional view taken along line 14-14 in Fig. 12;

Fig. 14 is a cross-sectional view taken along line 15-15 in Fig. 12;

Fig. 15 is a cross-sectional view taken along line 16-16 in Fig. 13;

Fig. 16 is a cross-sectional view taken along line 17-17 in Fig. 12;

Fig. 17 is a perspective view showing a piston;

Fig. 18 is a perspective view showing a piston according to a first modification;

Fig. 19 is a perspective view showing a piston according to a second modification;

Fig. 20 is a perspective view showing a piston according to a third modification;

Fig. 21 is a partial enlarged cross-sectional view showing a prior art compressor; and

Fig. 22 is a partial enlarged cross-sectional view showing another prior art compressor.

BEST MODE FOR CARRYING OUT THE INVENTION

[0017] A first embodiment of a piston type variable displacement compressor according to the present invention will hereafter be described with reference to Figs. 1 through 7.

[0018] As shown in Fig. 1, a front housing 1 is secured to the front end of a cylinder block 2. A rear housing 3 is secured to the rear end of the cylinder block 2 with a valve plate 4 arranged in between. The front housing 1, the cylinder block 2, and the rear housing 3 constitute the housing of the compressor. A suction chamber 3a and a discharge chamber 3b are defined between the rear housing 3 and the valve plate 4. Refrigerant gas sent from an external refrigerant circuit (not shown) is directly drawn into the suction chamber 3a through an

intake port 3c.

[0019] The valve plate 4 is provided with suction ports 4a, suction valves 4b, discharge ports 4c, and discharge valves 4d. A crank chamber 5 is defined between the front housing 1 and the cylinder block 2. A rotary shaft 6 is rotatably supported by a pair of bearings 7 in the front housing 1 and the cylinder block 2 and extends through the crank chamber 5. A support hole 2b is defined in the center of the cylinder block 2. The rear end of the rotary shaft 6 is inserted into the support hole 2b and supported by the inner circumferential surface of the hole 2b by means of the bearing 7.

[0020] A lug plate 8 is fixed to the rotary shaft 6. A swash plate 9, which serves as a driving body, is supported in the crank chamber 5 by the rotary shaft 6 so that it is slidable and inclinable with respect to the axis L of the shaft 6. The swash plate 9 is connected to the lug plate 8 by a hinge mechanism 10. The hinge mechanism 10 is constituted by a support arm 19, which is defined on the lug plate 8, and a pair of guide pins 20, which are defined on the swash plate 9. The guide pins 20 are slidably fit into a pair of guide holes 19a, which are defined in the support arm 19. The hinge mechanism 10 integrally rotates the swash plate 9 with the rotary shaft 6. The hinge mechanism 10 also guides the movement and inclining of the swash plate 9 in the direction of the axis L.

[0021] A plurality of cylinder bores 2a are formed in the cylinder block 2 about the rotary shaft 6. The bores 2a extend along the direction of the axis L. A hollow single-headed piston 11 is retained in each cylinder bore 2a. A groove 11a is defined in the rear portion of the piston 11. A pair of shoes 12 are fit into the opposed inner walls of the groove 11a in a manner such that their semispheric portions are relatively slidable. The swash plate 9 is slidably held between the flat portions of the shoes 12. The rotating movement of the swash plate 9 is converted to linear reciprocating movement of the pistons 11 and causes each piston 11 to reciprocate forward and backward inside the cylinder bore 2a. During the suction stroke of the piston 11, in which it moves from the top dead center to the bottom dead center, the refrigerant gas flows through the suction port 4a, pushes and opens the suction valve 4b, and enters the cylinder bore 2a. During the compression stroke of the piston 11, in which it moves from the bottom dead center to the top dead center, the refrigerant gas in the cylinder bore 2a is compressed and discharged into the discharge chamber 3b as it flows through the discharge port 4c and pushes open the discharge valve 4d.

[0022] A thrust bearing 21 is arranged between the lug plate 8 and the front housing 1. A compression reaction force acts on the piston 11 as the refrigerant gas is compressed. The compression reaction force is received by the front housing 1 by way of the piston 11, the swash plate 9, the lug plate 8, and the thrust bearing 21.

[0023] As shown in Figs. 1 to 4, a rotation restricting

member 22 is provided integrally in the rear portion of the piston 11. The rotation restricting member 22 has a circumferential surface, the diameter of which is equal to that of the inner circumferential surface of the front housing 1. The circumferential surface of the rotation restricting member 22 contacts the inner circumferential surface of the front housing 1 to prohibit rotation of the piston 11 about its center axis S.

[0024] As shown in Fig. 1, a supply passage 13 connects the discharge chamber 3b with the crank chamber 5. An electromagnetic valve 14 is provided in the rear housing 3 arranged in the supply passage 13. Activation of a solenoid 14a in the electromagnetic valve 14 causes a valve body 14b to close a valve hole 14c. Deactivation of the solenoid 14a causes the valve body 14b to open the valve hole 14c.

[0025] A pressure releasing passage 6a is defined in the shaft 6. The releasing passage 6a has an inlet opened to the crank chamber 5 and an outlet opened to the inside of the support hole 2b. A pressure releasing hole 2c connects the inside of the support hole 2b with the suction chamber 3a.

[0026] When the solenoid 14a is activated and the supply passage 13 is closed, the high-pressure refrigerant gas in the discharge chamber 3b is not sent to the crank chamber 5. In this state, the refrigerant gas in the crank chamber 5 keeps flowing out into the suction chamber 3a through the pressure releasing passage 6a and the pressure releasing hole 2c. This causes the pressure level in the crank chamber 5 to approach the low pressure in the suction chamber 2a. Hence, the pressure difference between the inside of the crank chamber 5 and the inside of the cylinder bores 2a becomes small and causes the inclination of the swash plate 9 to become maximum, as shown in Fig. 1. This results in the displacement of the compressor to become maximum.

[0027] When the solenoid 14a is deactivated and the supply passage 13 is thus opened, the high-pressure refrigerant gas in the discharge chamber 3b is sent to the crank chamber 5 and increases the pressure in the crank chamber 5. As a result, the pressure difference between the inside of the crank chamber 5 and the inside of the cylinder bores 2a becomes large and causes the inclination of the swash plate 9 to become minimum. This results in the displacement of the compressor to become minimum.

[0028] Abutment of a stopper 9a, which is provided on the front surface of the swash plate 9, against the lug plate 8 restricts the swash plate 9 from inclining beyond the predetermined maximum inclination. Abutment of the swash plate 9 and a ring 15, which is provided on the rotary shaft 6, restricts the swash plate 9 at the minimum inclination.

[0029] As described above, the pressure inside the crank chamber 5 is adjusted by opening and closing the supply passage 13 in correspondence with the activation and deactivation of the solenoid 14a of the electro-

magnetic valve 14. Alteration of the pressure inside the crank chamber 5 also alters the difference between the pressure in the crank chamber 5 that acts on the front side of the pistons 11 (left side as viewed in Fig. 1) and the pressure in the cylinder bores 2a that acts on the rear side of the pistons 11 (right side as viewed in Fig. 1). This alters the inclination of the swash plate 9. The alteration in the inclination of the swash plate changes the moving stroke of the pistons 11 and adjusts the displacement of the compressor. The solenoid 14a of the electromagnetic valve 14 is controlled by a controller (not shown) and selectively excited and de-excited in accordance with data such as that of the cooling load. In other words, the displacement of the compressor is adjusted in accordance with the cooling load.

[0030] As shown in Figs. 1 through 5, a first annular groove 16, which serves as a recovering means, is defined in the front outer circumferential surface of each piston 11 extending in the circumferential direction. As shown in Fig. 4, the first groove 16 is defined at a position where the groove 16 is not exposed to the inside of the crank chamber 5 when the piston 11 is located at the bottom dead center. Figs. 1 through 4 illustrate the swash plate 9 in a maximum inclination state.

[0031] A second groove 17, which serves as a communicating means, is also defined in the outer circumferential surface of the piston 11 extending along its center axis S. The basal end of the second groove 17 is located in the vicinity of the first groove 16. The second groove 17 is located on the circumferential surface of the piston 11 at a position described below. As shown in Fig. 6(b), when viewing the piston 11 so that the rotating direction R of the rotary shaft 6 is clockwise (in this drawing, the piston 11 is viewed from its rear side), an imaginary straight line M extends intersecting the axis L of the rotary shaft 6 and the axis S of the piston 11. Among the two intersecting points P1, P2 at which the straight line M and the circumferential surface of the piston 11 intersect, the position of the intersecting point P1, located at the farther side of the circumferential surface with respect to the axis L of the piston 11, is herein referred to as the twelve o'clock position. In this case, the second groove 17 is located within a range E, which is defined between positions corresponding to nine o'clock and ten thirty on the circumferential surface of the piston 11.

[0032] As shown in Fig. 2, the position and length of the second groove 17 is determined so that it is not exposed from the cylinder bore 2a to the inside of the crank chamber 5 when the piston 11 moves near the top dead center. The second groove 17 is not connected with the first groove 16. As shown in Fig. 5, an inner bottom surface 18 defined at the distal side of the second groove 17 is sloped in a manner such that it is smoothly and continuously connected to the circumferential surface of the piston 11.

[0033] The surface of the piston 11 is ground using a centerless grinding method. The centerless grinding

method, which is not shown, grinds the workpiece, or piston 11, which is held on a rest, by rotating it together with a grinding wheel without using a chuck to hold the piston 11. Therefore, if a plurality of second grooves 17 are provided in the circumferential surface of the piston 11, the rotating axis of the piston 11 placed on the rest becomes unstable. This hinders precision grinding. Accordingly, it is desirable that the number of second grooves 17 be minimized so as to enable accurate grinding when employing the centerless grinding method. In this embodiment, the piston 11 is provided with only a single second groove 17, the width and depth of which are minimized but are sufficient to supply lubricating oil to the crank chamber 5.

[0034] In the above compressor, when each piston 11 is moved from the top dead center to the bottom dead center during the suction stroke, the refrigerant gas in the suction chamber 3a is drawn into the cylinder bore 2a. During this stroke, a portion of the lubricating oil suspended in the refrigerant gas adheres to the inner circumferential surface of the cylinder bore 2a. Contrarily, when each piston 11 is moved from the bottom dead center to the top dead center during the compression stroke, the refrigerant gas in the in the cylinder bore 2a is compressed and then discharged into the discharge chamber 3b. During this stroke, a portion of the refrigerant gas in the bore 2a leaks into the crank chamber 5 through a narrow clearance K defined between the outer circumferential surface of the piston 11 and the inner circumferential surface of the bore 2a as blowby gas. Some of the lubricating oil contained in the blowby gas adheres to the inner circumferential surface of the bore 2a.

[0035] The lubricating oil adhered to the inner circumferential surface of the cylinder bore 2a is removed by the edge 16a of the first groove 16 of the piston 11 as the piston 11 reciprocates and is collected in the first groove 16.

[0036] During the compression stroke of the piston 11, the refrigerant gas leaking from the cylinder bore 2a (blow-by gas) increases the pressure in the first groove 16. The second groove 17 is entirely closed by the inner circumferential surface of the cylinder bore 2a only when the piston 11 is located near the top dead center. Otherwise, at least a portion of the second groove 17 is exposed to the inside of the crank chamber 5. Therefore, the pressure in the second groove 17 is equal to or slightly higher than the pressure in the crank chamber 5. The first groove 16 is connected to the second groove 17 by way of the narrow clearance K. Accordingly, during the compression stroke of the piston 11, the lubricating oil in the first groove 16 flows into the second groove 17 by way of the clearance K by the difference between the pressure in the first groove 16 and the pressure in the second groove 17. The lubricating oil that enters the second groove 17 flows into the crank chamber 5 by way of the portion of the second groove 17 that is exposed to the inside of the crank chamber 5. The lubricating oil

is supplied to the coupling portion between the swash plate 9 and the piston 11, that is, between the swash plate 9 and the shoes 12 and between the shoes 12 and the piston 11. This satisfactorily lubricates these portions.

[0037] When the inclination of the swash plate 9 becomes small, the second groove 17 may not be exposed from the inside of the cylinder bore 2a even when the piston 11 is located at the bottom dead center. However, in this embodiment, the distance between the distal end of the second groove 17 and the rear edge of the piston 11 is short. Thus, the lubricating oil in the second groove 17 is easily discharged toward the crank chamber 5 by way of the clearance K. This satisfactorily lubricates the coupling portion between the swash plate 9 and the piston 11 among other parts.

[0038] In this manner, the lubricating oil collected by the first groove 16, which serves as a recovering means, is supplied to the crank chamber 5 by the second groove 17, which serves as a communicating means.

[0039] During the reciprocating movement of the piston 11, the reaction force from the inner circumferential surface of the cylinder bore 2a (hereafter referred to as the side force) produced by the compression reaction force and the inertial force of the piston 11 is received by the piston 11. Hence, it is preferable that the second groove 17 be provided at a position at which the influence of the side force is minimal (the position corresponding to range E as shown in Fig. 6(b)).

[0040] More particularly, as shown in Fig. 2 and Fig. 7, when the piston 11 is located near the top dead center, the compression reaction force that acts on the piston 11 becomes maximum. The compression reaction force and the inertial force of the piston 11 act on the swash plate 9. Accordingly, the piston 11 receives a large reaction force F_s in accordance with the resultant force F_o of the compression reaction force and the inertial force from the swash plate 9, which is inclined with respect to a plane that is perpendicular to the center axis L of the rotary shaft 6. In accordance with the inclination of the swash plate 9, the reaction force F_s is divided into a component force f_1 , which is oriented along the moving direction of the piston 11, and a component force f_2 , which is oriented toward the center axis L of the rotary shaft 6. The component force f_2 acts as a force that inclines the rear side of the piston 11 in the direction of the component force f_2 . Thus, the circumferential surface of the rear side of the piston 11 is pressed against the inner circumferential surface of the cylinder bore 2a at the vicinity of its opening by a force corresponding to the component force f_2 . In other words, the circumferential surface at the rear side of the piston 11 receives a large reaction force (side force) F_a corresponding to the component force f_2 from the inner circumferential surface of the cylinder bore 2a at the vicinity of its opening.

[0041] The position at which the side force F_a acts on the piston 11 varies as the piston 11 moves. For exam-

ple, as the swash plate 9 rotates 90 degrees in the direction of arrow R from the state shown in Fig. 2 to the state shown in Fig. 3, the compressed refrigerant gas residing in the cylinder bore 2a re-expands as the piston 11 moves from the top dead center to the bottom dead center. When the swash plate 9 approaches the state shown in Fig. 3, the re-expansion of the compressed refrigerant gas in the cylinder bore 2a is completed and the suction of refrigerant gas into the cylinder bore 2a is commenced. In this state, the compression reaction force does not act on the swash plate 9 and the force F_o that acts on the piston 11 is mainly constituted by inertial force. Accordingly, the piston 11 receives the reaction force F_s , which is mainly constituted by inertial force. In accordance with the inclination of the swash plate 9, the reaction force F_s is divided into a component force f_1 , which is oriented along the moving direction of the piston 11, and a component force f_2 , which is oriented toward the rotating direction R of the swash plate 9. The component force f_2 acts as a force that inclines the rear side of the piston 11 in the direction of the component force f_2 . Thus, the piston 11 receives a side force F_a corresponding to the component force f_2 from the inner circumferential surface of the cylinder bore 2a at the vicinity of its opening. As described later, when the swash plate 9 is in the state shown in Fig. 3, the force F_o acting on the swash plate 9 is substantially zero. Thus, practically no side force F_a acts on the piston 11.

[0042] When the swash plate 9 is further rotated 90 degrees in the direction of arrow R from the state shown in Fig. 3 to the state shown in Fig. 4, the piston 11 is located at the bottom dead center. In this state, the orientation of the component force f_2 that acts on the piston 11 becomes opposite to that of Fig. 2 (the state in which the piston 11 is located at the top dead center). Accordingly, the piston 11 receives a side force F_a oriented in the opposite direction to that of Fig. 2 from the inner circumferential surface of the cylinder bore 2a at the vicinity of its opening. The level of the side force F_a is greater than that of Fig. 2.

[0043] As shown in Fig. 2 and Fig. 7, the front portion of the piston 11 receives a side force F_b that corresponds to the component force f_2 from the inner circumferential surface of the cylinder bore 2a at its inner side. However, the first groove 16 is provided at the front side of the piston 11. The second groove 17 is provided at a position that is at least closer to the rear side of the piston 11 than the first groove 16. Accordingly, along the entire circumferential surface of the piston 11, the side force F_b does not act directly on the range between the basal end and distal end of the second groove 17. Therefore, the side force F_b that acts on the front side of the piston 11 need not be considered when determining the optimum position of the second groove with respect to the circumferential direction of the piston 11.

[0044] Fig. 6(a) illustrates a graph indicating the relationship between the rotational angle of the rotary shaft 6 (i.e., the location of the piston 11) and the level of the

side force F_a acting on the piston 11. In this graph, the rotational angle of the rotary shaft 6 when the piston 11 is located at the top dead center corresponds to zero degrees. The schematic drawings provided under the longitudinal axis of the graph illustrates the orientation of the side force F_a acting on the piston 11 in correspondence with the rotational angle of the rotary shaft 6 indicated along the longitudinal axis. The schematic drawings show that the orientation of the portion of the piston 11 on which the side force F_a acts changes in the rotating direction R of the rotary shaft 6 as the rotary shaft 6 and the swash plate 9 rotate. In other words, the side force F_a acts sequentially along the entire circumference of the piston 11 as the piston 11 reciprocates once between the top dead center and the bottom dead center to perform the suction and compression strokes.

[0045] As shown in Fig. 6(a), as the rotary shaft 6 rotates 90 degrees from the state at which the piston is located at the top dead center, that is, as the swash plate 9 rotates from the state shown in Fig. 2 to the state shown in Fig. 3, the value of the side force F_a may become negative. This indicates that the orientation of each force shown in Fig. 3 reverses before the swash plate 9 reaches the state shown in Fig. 3.

[0046] The graph of Fig. 6(a) indicates that the side force acting on the piston 11 becomes maximal when the rotational angle of the rotary shaft 6 is zero degrees (=360 degrees), that is, when the piston 11 is located at the top dead center. As shown in Fig. 6(b), the location on the circumferential surface of the piston 11 that receives the maximum side force F_a corresponds to the six o'clock position. When a large side force F_a acts on the position corresponding to six o'clock, a range E1, which extends between the positions corresponding to three o'clock and nine o'clock about the six o'clock position on the circumferential surface of the piston 11, is strongly pressed against the inner circumferential surface of the cylinder bore 2a. Therefore, when the second groove 17 is provided within the range E1, the edge of the second groove 17 strongly presses the inner circumferential surface of the cylinder bore 2a and may thus cause abrasive wear or damage to the piston 11 and the cylinder bore 2a. Accordingly, it is preferable that the second groove 17 be provided on the circumferential surface of the piston 11 within a range excluding the range E1 that extends between three o'clock and nine o'clock, that is, range E2, which extends between nine o'clock and three o'clock.

[0047] To further avoid the influence of the side force F_a , it is preferable that the second groove 17 be provided in a range that receives minimal side force F_a within the range E2, which extends between nine o'clock and three o'clock on the circumferential surface of the piston 11. The graph of Fig. 6(a) indicates that the side force F_a acting on the piston 11 is relatively smaller during the suction stroke of the piston 11 (when the rotational angle of the rotary shaft 6 is within 0 degrees to 180 degrees) than during the compression stroke of the piston 11

(when the rotational angle of the rotary shaft 6 is within 180 degrees to 360 degrees).

[0048] After the re-expansion of the residual refrigerant gas in the cylinder bore 2a is completed during the suction stroke, the swash plate 9 is free from compression reaction force and the force acting on the piston 11 is mostly constituted by inertial force. In particular, as shown in Fig. 6(a), when the rotational angle of the rotary shaft 6 corresponds to 90 degrees (when the swash plate 9 is in the state shown in Fig. 3), there is almost no side force F_a acting on the circumferential surface of the piston 11 at the position corresponding to nine o'clock. Accordingly, the side force F_a acting on the piston 11 becomes relatively smaller during the suction stroke than during the compression stroke, in which compression reaction force is produced. In other words, within the range E2 extending between nine o'clock to three o'clock on the circumferential surface of the piston 11, the side force F_a acting in the range between nine o'clock to twelve o'clock is relatively smaller than the side force F_a acting in the range between twelve o'clock and three o'clock.

[0049] In addition, as shown in Fig. 6(a), when the piston 11 is arranged at the bottom dead center, a relatively large side force F_a acts on the circumferential surface of the piston 11 at a position corresponding to twelve o'clock. When the piston 11 approaches the bottom dead center, the length of the piston 11 supported by the cylinder bore 2a becomes short. Thus, there is a tendency for the piston 11 to become unstable. Therefore, it is preferable that the second groove 17 not be provided in the vicinity of the twelve o'clock position on the circumferential surface of the piston 11.

[0050] Accordingly, in this embodiment, the second groove 17 is provided in the range E extending between the nine o'clock position and the ten thirty position on the circumferential surface of the piston 11, as shown in Fig. 6(b).

[0051] The following advantages are obtained from the first embodiment having the above structure.

(1) The lubricating oil collected in the first groove 16 is positively supplied to the crank chamber 5 by way of the second groove 17, which extends on the piston 11 so as to extend along the center axis S. Therefore, various parts in the crank chamber 5 such as the coupling portion between the swash plate 9 and the piston 11 are satisfactorily lubricated even when the refrigerant gas from the external refrigerant circuit is drawn into the suction chamber 3a without flowing through the suction chamber 3a.

(2) The annular first groove 16, which is defined in the circumferential direction of the piston 11, is not exposed from the inside of the cylinder bore 2a even when the piston 11 is located at the bottom dead center. Thus, the first groove 16 does not interfere with the edge of the cylinder bore 2a. The second

groove 17, which extends in the direction of the axis S of the piston 11, also does not interfere with the edge of the cylinder bore 2a. Accordingly, the piston 11 reciprocates smoothly. Furthermore, abrasive wear and damage to the piston 11 and the cylinder bore 2a are prevented.

(3) The annular first groove 16 collects the adhered lubricating oil from the entire inner circumferential surface of the cylinder bore 2a. Thus, it is possible to maximize the amount of lubricating oil supplied into the crank chamber 5.

(4) In the compressor of this embodiment, the rotating movement of the swash plate 9 is converted to reciprocating movement of the piston 11. In such a compressor, the piston 11 is pressed against the inner circumferential surface of the cylinder bore 2a by the compression reaction force acting on the swash plate 9 and the inertial force of the piston 11. Accordingly, it is particularly effective to embody the structure of the present invention in such a type of compressor.

(5) The first groove 16 and the second groove 17 are not directly connected to each other on the circumferential surface of the piston 11. The grooves 16, 17 are communicated with each other through the narrow clearance K defined between the piston 11 and the cylinder bore 2a. Accordingly, the refrigerant gas in the first groove 16 flows into the second groove 17 in a state restricted by the clearance K. This slows the flow of refrigerant gas. Thus, when the piston 11 is located near the top dead center, the high-pressure refrigerant gas in the cylinder bore 2a is prevented from flowing abruptly through the grooves 16, 17 into the cylinder bore 2a. As a result, a decrease in the compressing efficiency of the compressor is ultimately prevented.

(6) The inner bottom surface at the distal side of the second groove 17 is a sloped surface that is gradually connected to the circumferential surface of the piston 11. Thus, when the piston 11 moves from the bottom dead center to the top dead center, the distal edge of the second groove 17 is prevented from interfering with the edge of the cylinder bore 2a. As a result, the piston 11 moves smoothly while abrasive wear and damage of the piston 11 and cylinder bore 2a are positively prevented.

(7) The second groove 17 is defined on the circumferential surface of the piston 11 at a position (the position corresponding to range E in Fig. 6(b)) which the influence of the side force F_a produced by the compression reaction force and the inertial force of the piston 11 is minimal. Accordingly, the portion of the second groove 17 in the piston 11 is

prevented from being pressed strongly by the cylinder bore 2a. This further positively prevents abrasive wear and damage of the piston 11 and the cylinder bore 2a.

(8) Since the piston 11, which is hollow, is light in weight, the inertial force of the piston 11 is small. When the inertial force is small, abrasive wear and damage of the piston 11 and the cylinder bore 2a is further effectively prevented.

(9) Thermal expansion of the piston 11 takes place as the operation of the compressor gradually increases the temperature of the compressor. The rate of thermal expansion in hollow objects is slightly smaller than that of solid objects. The piston 11 in this embodiment is hollow. This suppresses the clearance K, which is defined between the circumferential surface of the piston 11 and the inner circumferential surface of the cylinder bore 2a, from becoming small due to thermal expansion of the piston 11. Thus, an increase in the sliding resistance between the piston 11 and the cylinder bore 2a is prevented.

(10) The compressor of this embodiment is a variable displacement compressor, the discharge volume of which may be controlled. In such a compressor, a clutch that transmits and cuts off drive force is not provided between an external drive force and the rotary shaft of the compressor. The external drive force and the compressor are directly connected to each other. Thus, the compressor of this embodiment is operated as long as the external drive source is moving. Satisfactory lubrication of each part is important in such a compressor. In other words, it is very effective to employ the piston 11 of this embodiment, which is provided with the first groove 16 and the second groove 17, in a variable displacement compressor.

[0052] The above first embodiment may also be modified as described below.

[0053] A first modified form will now be described. As shown in an exaggerated manner in Fig. 7, when the piston 11 is located near the top dead center, the piston 11 becomes inclined in the cylinder bore 2a in a counterclockwise direction, as viewed in the drawing. This causes the lower side of the first groove 16, as viewed in the drawing, to be opened toward the inner side of the cylinder bore 2a. As a result, the high-pressure refrigerant gas compressed in the cylinder bore 2a leaks into the first groove 16 and decreases the compressing efficiency.

[0054] Thus, in the first modified form, the first groove 16 is provided only on the upper half of the circumferential surface of the piston 11, as shown in Fig. 8. In other words, the first groove 16 is defined in the circum-

ferential surface of the piston 11 only within range E2, which extends between nine o'clock and three o'clock, as shown in Fig. 6(b). This structure prevents the first groove 16 from being opened toward the inner side of the cylinder bore 2a even when the piston 11 located near the top dead center and is inclined as shown in Fig. 7. As a result, the high-pressure refrigerant gas compressed in the cylinder bore 2a does not leak into the first groove 16. Thus, a decrease in the compressing efficiency of the compressor is prevented.

[0055] A second modified form will now be described. In the second modified form, the second groove 17 is connected to the first groove 16, as shown in Fig. 9. This enables the lubricating oil in the first groove 16 to flow smoothly into the second groove 17.

[0056] A third modified form will now be described. In the third embodiment, the distal end of the second groove 17 extends to the rear peripheral edge of the piston 11 and the second groove 17 is always directly connected with the crank chamber 5. This prevents interference between the distal end of the second groove 17 and the edge of the cylinder bore 2a when the piston 11 moves from the top dead center to the bottom dead center. As a result, the piston 11 reciprocates further smoothly, and abrasive wear and damage of the piston 11 and the cylinder bore 2a is further securely prevented. In addition, the lubricating oil in the second groove 17 enters the crank chamber 5 further smoothly. As shown in the double-dotted line in Fig. 10, in the third modified form, the second groove 17 may further be connected to the first groove 16 to constantly communicate the first groove 16 with the crank chamber 5 in the same manner as the above second modified.

[0057] A fourth modified form will now be described. As shown in Fig. 11(a), in the fourth embodiment, a plurality (three in the drawing) of elongated hole like grooves 16a, 16b, 16c are arranged along the circumferential direction of the piston 11. The second groove 17 is constituted by a plurality of grooves 17a, 17b, 17c, each corresponding to the grooves 17a, 17b, 17c, respectively. As shown in the double-dotted line of Fig. 11 (a), at least one of the three grooves 17a, 17b, 17c constituting the second groove 17 may be extended to the rear peripheral edge of the piston 11 so that it is constantly connected to the crank chamber 5.

[0058] As shown in Fig. 11(b), in a fifth modified form, the grooves 17a, 17b, 17c of the fourth modified form are each connected to the corresponding grooves 16a, 16b, 16c. As shown in the double-dotted line of Fig. 11 (b), at least one of the three grooves 17a, 17b, 17c constituting the second groove 17 may be extended to the rear peripheral edge of the piston 11 so that it is constantly connected to the crank chamber 5.

[0059] As shown in Fig. 11(c), in a sixth modified form, the side grooves 17a, 17c are connected midway of the center groove 17b in the second groove 17 of the fourth modified form. As shown in the double-dotted line of Fig. 11(c), the center groove 17b may be extended to the

rear peripheral edge of the piston 11 so that it is constantly connected to the crank chamber 5.

[0060] As shown in the double-dotted line of Fig. 5, in the seven modified form, the second groove 17 is defined in the inner circumferential surface of the cylinder bore 2a. The second groove 17 is extended to the edge of the cylinder bore 2a so that it is constantly connected to the crank chamber 5. In this case, the circumferential surface of the piston 11 may either be provided or not provided with the second groove 17.

[0061] As shown in the double-dotted line of Fig. 6(b), in the ninth modified form, the second groove 17 is provided within a range E3, which extends between seven thirty to nine o'clock on the circumferential surface of the piston 11. As described above, when a large side force Fa acts on the circumferential surface of the piston 11 at a position corresponding to six o'clock, the range E1, which extends between three o'clock and nine o'clock about the six o'clock position, is strongly pressed against the inner circumferential surface of the cylinder bore 2a.

[0062] However, the most strongly pressed position is the six o'clock position.

[0063] The pressing force becomes weaker at positions located farther from the six o'clock position.

[0064] Accordingly, the range E3, which extends separated from the six o'clock position and between seven thirty and nine o'clock, is not as strongly pressed against the inner circumferential surface of the cylinder bore 2a. In addition, as shown in Fig. 6(a), the value of the side force Fa becomes negative just before the rotational angle of the rotary shaft 6 reaches 90 degrees. This indicates that the side force Fa does not directly act on the circumferential surface of the piston 11 within the range E3 extending between seven thirty and nine o'clock.

[0065] Accordingly, there are no problems when the second groove 17 is provided within the range E3, which extends between seven thirty and nine o'clock on the circumferential surface of the piston 11.

[0066] A second embodiment according to the present invention will now be described with reference to Fig. 12 to Fig. 17. In the second embodiment, parts that are identical to those in the first embodiment will be denoted with the same numeral and will not be described. Generally, parts that differ from the first embodiment will be described hereafter.

[0067] As shown in Fig. 12, the compressor of the second embodiment has a structure that is basically similar to that of the first embodiment. In other words, the rotating movement of the swash plate 9 produced by the rotation of the rotary shaft 6 is converted to reciprocating movement of the piston 11 in the cylinder bore 2a by means of the shoes 12.

[0068] A pulley 26 is fixed to the front end of the rotary shaft 6. The pulley 26 is rotatably supported by the front end of the front housing 1 by means of an angular bearing 27. The pulley 26 is operatively connected to a vehicle engine (not shown), which is an external drive

force, by a belt 28. The angular bearing 27 receives load acting in the thrust direction and the radial direction.

[0069] An accommodating hole 29 is defined in the center of the cylinder block 1 and extends along the axis L of the rotary shaft 6. A tubular spool 30 having a closed rear is slidably accommodated in the accommodating hole 29. A coil spring 31 is arranged between the spool 30 and the inner circumferential surface of the accommodating hole 29. The coil spring 31 urges the spool 30 toward the swash plate 9.

[0070] The rear end of the rotary shaft 6 is inserted in the spool 30. A radial bearing 32 is arranged between the rear end of the rotary shaft 6 and the inner circumferential surface of the spool 30. The rear end of the rotary shaft 6 is supported by the inner circumferential surface of the accommodating hole 29 by way of the bearing 32 and the spool 30. The bearing 32 may be moved together with the spool 30 along the axis L of the rotary shaft 6. A thrust bearing 33 is arranged on the rotary shaft 6 between the spool 30 and the swash plate 9. The thrust bearing 33 is movable along the axis L of the rotary shaft 6.

[0071] A suction passage 34 is defined in the center of the rear housing 3. The suction passage 34 is communicated with the accommodating hole 29. A positioning surface 35 is defined on the valve plate 4 between the accommodating hole 29 and the suction chamber 34. The rear end face of the spool 30 may be abutted against the positioning surface 35. The abutment of the rear end face of the spool 30 against the positioning surface 35 restricts the spool 30 from moving away from the swash plate 9 and also cuts off the communication between the suction passage 34 and the accommodating passage 29.

[0072] When the swash plate 9 moves toward the spool 30 as its inclination decreases, the swash plate 9 presses the spool 30 by way of the thrust bearing 33. Thus, the spool 30 is moved toward the positioning surface 35 against the urging force of the coil spring 31. This abuts the spool 30 against the positioning surface 35. The abutment restricts the swash plate 9 so that its inclination is minimal. The minimum inclination of the swash plate 9 is slightly greater than zero degrees. The inclination of the swash plate 9 corresponds to zero degrees when arranged on a plane perpendicular to the rotary shaft 9.

[0073] The suction chamber 3a is communicated with the accommodating hole 29 through a communicating port 36. When the spool 30 abuts against the positioning surface 35, the communicating port 36 is disconnected from the suction passage 34. A pressure releasing passage 6a defined in the rotary shaft 6a has an inlet, which is connected with the crank chamber 5, and an outlet, which is connected to the inside of the spool 30. A pressure releasing port 37 is defined in the circumferential surface of the spool 30 at its rear end. The pressure releasing hole 37 connects the interior of the spool 30 to the accommodating hole 29.

[0074] An external refrigerating circuit 37 connects the suction passage 34, through which refrigerant gas is drawn toward the suction chamber 3a, and a discharge port 38, through which the refrigerant gas from the discharge chamber 3b is discharged. The external refrigerant circuit 37 is provided with a condenser 39, an expansion valve 40, and an evaporator 41. A temperature sensor 42 is arranged in the vicinity of the evaporator 41. The temperature sensor 42 detects the temperature of the evaporator 41 and sends a signal corresponding with the detected temperature to a controller C.

[0075] The controller C controls the solenoid 14a of the electromagnetic valve 14 in accordance with the signal from the temperature sensor 42. The controller C de-excites the solenoid 14a to prevent the forming of frost in the evaporator 41 if the temperature detected by the temperature sensor 42 becomes equal to or lower than a predetermined value when an activating switch 43 for activating an air-conditioning apparatus is turned on. The controller C also de-excites the solenoid 14a when the activating switch 43 is turned off.

[0076] The high-pressure refrigerant gas in the discharge chamber 3b is supplied to the crank chamber 5 when the de-exciting of the solenoid 14a opens the supply passage 13. This increases the pressure in the crank chamber 5. Thus, in the same manner as the first embodiment, the swash plate 9 is moved to the minimum inclination. When the spool 30 abuts against the positioning surface 35, the inclination of the swash plate 9 becomes minimum and the suction passage 34 becomes disconnected from the suction chamber 3a. Accordingly, the refrigerant gas stops flowing into the suction chamber 3a from the external refrigerant circuit 37. This stops the circulation of the refrigerant gas between the external refrigerant circuit 37 and the compressor.

[0077] Since the minimum inclination of the swash plate 9 is not zero degrees, the refrigerant gas is drawn into the cylinder bore 2a from the suction chamber 3 and discharged into the discharge chamber 3b from the cylinder bore 2a even when the inclination of the swash plate 9 becomes minimum. Therefore, when the inclination of the swash plate 9 is minimum, the refrigerant gas circulates through a circulation passage in the compressor flowing through the discharge chamber 3a, the supply passage 13, the crank chamber 5, the pressure releasing passage 6a, the pressure releasing port 30a, the suction chamber 3a, and the cylinder bore 2a. Accordingly, the lubricating oil that flows together with the refrigerant gas lubricates each part in the compressor. A pressure difference is produced between the discharge chamber 3, the crank chamber 5, and the suction chamber 3a. The pressure difference and the cross-sectional area of the pressure releasing port 30a greatly affect the stabilization of the swash plate 9 at the minimum inclination.

[0078] When the exciting of the solenoid 14a closes the supply passage 13, the refrigerant gas in the crank

chamber 5 flows through the pressure releasing passage 6a and the pressure releasing port 30a into the suction chamber 3a. This causes the pressure in the crank chamber 5 to approach the low pressure in the suction chamber 3a. Thus, in the same manner as the first embodiment, the swash plate 9 moves to the maximum inclination.

[0079] Fig. 13 is a cross-sectional view taken along line 14-14 in Fig. 12. Fig. 13 mainly shows a hinge mechanism 10, which couples the swash plate 9 and the lug plate 8 to each other, and the rotation restricting member 22, which is provided on the piston 11 to prohibit rotation of the piston 11. Fig. 14 is a cross-sectional view taken along line 15-15 in Fig. 12. Fig. 14 mainly shows the suction chamber 3a, which is defined in the rear housing 3, and the relationship between the discharge chamber 3b and the cylinder bore 2a.

[0080] As shown in Fig. 12 and Figs. 15 to 17, a plurality of grooves 44 are defined along the center axis S of the piston 11 in the outer circumferential surface of the piston 11. In other words, the first groove 16 employed in the first embodiment is not employed in the second embodiment. Only the grooves 44, which correspond to the second groove 17, are provided. The grooves 44 are provided in the circumferential surface of the piston 11 at positions described below. As shown in Fig. 16, in the same manner as the first embodiment, when viewing the piston 11 so that the rotating direction R of the rotary shaft 6 is clockwise (in this drawing, the piston 11 is viewed from its front side), the imaginary straight line M extends intersecting the axis L of the rotary shaft 6 and the axis S of the piston 11. Among the two intersecting points P1, P2 at which the straight line M and the circumferential surface of the piston 11 intersect, the position of the intersecting point P1, located at the farther side of the circumferential surface with respect to the axis L of the piston 11, is hereby referred to as the twelve o'clock position.

[0081] In Fig. 12, the piston 11 shown at the lower side is arranged at the bottom dead center. When the piston 11 is arranged near the bottom dead center, portions of the grooves 44 are exposed from the cylinder bore 2a toward the inside of the crank chamber 5.

[0082] As shown in Fig. 16, a pair of recesses 45 are defined in the circumferential surface of the piston 11 at a range E1, which extends between three o'clock and nine o'clock. By providing the recesses 45, the piston 11 becomes hollow. As a result, the weight of the piston 11 is lessened in the same manner as the first embodiment. The recesses 45 are opened to the outer circumferential surface of the piston 11 and extend along the center axis S of the piston 11. Accordingly, in the same manner as the grooves 44, the recesses 45 have the same function as the second groove 17 of the first embodiment.

[0083] As described in the first embodiment, when a large side force Fa acts on the six o'clock position at the circumferential surface of the piston 11, a range E1,

which extends between three o'clock and nine o'clock about the six o'clock position on the circumferential surface, is strongly pressed against the inner circumferential surface of the cylinder bore 2a. In addition, when the piston 11 is arranged at the bottom dead center, a relatively large side force F_a acts on the twelve o'clock position on the circumferential surface of the piston 11.

[0084] Furthermore, when the piston 11 is arranged between the top dead center and the bottom dead center during the suction stroke as shown in Fig. 15, the piston 11 receives a reaction force F_s corresponding to the resultant force F_o of the compression reaction force and the inertial force from the swash plate 11. The reaction force F_s is divided into a component force f_1 , which is oriented along the moving direction of the piston 11, and a component force f_2 , which is oriented toward the rotating direction R of the swash plate 9. The component force f_2 acts as a force that inclines the rear side of the piston 11 in the direction of the component force f_2 . In addition, a sliding resistance is provided between the swash plate 9 and the shoes 12. Hence, the rotation of the swash plate 9 produces a force that inclines the rear side of the piston 11 in the same direction as the component force f_2 . Accordingly, when the rotating speed of the swash plate 9 is high, a large side force F_a acts on the circumferential surface of the piston 11 at the three o'clock position.

[0085] Taking into consideration the above, in this embodiment, the grooves 44 are provided on the circumferential surface of the piston 11 at locations excluding the twelve o'clock position and the range $E1$ that extends between three o'clock and nine o'clock. In other words, the grooves 44 are defined in the circumferential surface of the piston 11 at positions where influence of the side force F_a is small. Accordingly, the portion of the grooves 44 in the piston 11 is prevented from being strongly pressed by the cylinder bore 2a. This enables the piston 11 to slide smoothly in the cylinder bore 2a.

[0086] The lubricating oil adhered to the inner circumferential surface of the cylinder bore 2a is also collected in the grooves 44 during the reciprocation of the piston 11 in the second embodiment. When the piston 11 moves near the bottom dead center, the grooves 44 become exposed to the inside of the crank chamber 5 from the cylinder bore 2a, and the lubricating oil collected in the grooves 44 are supplied to the crank chamber 5. Thus, even if the circumferential surface of the piston 11 is provided with only the grooves 44 that extend along the center axis S of the same piston 11, the coupling portion between the swash plate 9 and the piston 11 may be satisfactorily lubricated in the same manner as the first embodiment.

[0087] Since the second embodiment does not employ the first groove 16 of the first embodiment, problems such as interference between a groove extending in the circumferential direction of the piston 11 and the edge of the cylinder bore 2a do not occur. Additionally, the advantageous effects of the first embodiment may

be obtained by defining the grooves 44 at locations that receive little influence from the side force F_a . Furthermore, the advantageous effects of having the piston 11 formed in a hollow manner is the same as the first embodiment.

[0088] The sliding resistance between the outer circumferential surface of the piston 11 and the inner circumferential surface of the cylinder bore 2a becomes greater as the clearance K between the outer circumferential surface of the piston 11 and the inner circumferential surface of the cylinder bore 2a becomes smaller. This is due to an adhering force that is produced between the piston 11 and the cylinder bore 2a by a force acting between the molecules of the lubricating oil contained in the refrigerant gas. The adhering force becomes smaller as the clearance K becomes larger. The lubricating oil exists between the outer circumferential surface of the piston 11 and the inner circumferential surface of the cylinder bore 2a. The refrigerant gas in the cylinder bore 2a that leaks into the crank chamber 5 through the clearance K during compression is thus suppressed. It is important that the leakage of the refrigerant gas be suppressed to improve the compressing efficiency of the compressor. Thus, the depth of the grooves 44 is determined so as to minimize the adhering force produced by the force acting between the molecules of the lubricating oil and to be within a range that does not degrade the refrigerant gas leakage suppressing function of the lubricating oil. Such grooves 44 decrease the sliding resistance between the outer circumferential surface of the piston 11 and the inner circumferential surface of the cylinder bore 2a.

[0089] Like the first embodiment, the compressor of this embodiment is a variable displacement compressor and is thus operated as long as the external drive source is moving. Accordingly, in such a type of compressor, a decrease in the sliding resistance between the piston 11 and the cylinder bore 2a prevents a large degree of power loss. Thus, it is extremely effective when the piston 11 provided with the grooves 44 is employed in compressors that are directly connected with the external drive source.

[0090] The second embodiment may be modified in the forms described below.

[0091] A first modified form will now be described. In the above second embodiment, the grooves 44, which have a relatively wide width, are defined in the piston 11. However, as shown in Fig. 18, in lieu of the grooves 44 of the second embodiment, a plurality of line-like grooves 46 are defined extending along the center axis S in the circumferential surface of the piston 11 in this modified form. The grooves 46 are provided in the circumferential surface of the piston 11 at substantially the same location as the grooves 44. In the same manner as the grooves 44 of the second embodiment, the depth of the grooves 46 is determined so as to minimize the adhering force produced by the force acting between the molecules of the lubricating oil and to be within a range

that does not degrade the refrigerant gas leakage suppressing function of the lubricating oil. Accordingly, the advantageous effects of the second embodiment are also obtained in the first modified form.

[0092] In a second modified form, as shown in Fig. 19, the grooves 44 are provided in the circumferential surface of the piston 11 at a location excluding the six o'clock position and the range E2, which extends between nine o'clock and three o'clock. The grooves 44 are identical to the grooves 44 described in the second embodiment. The advantageous effects of the second embodiment are also obtained in the second modified form.

[0093] In a third modified form, as shown in Fig. 20, the grooves 44 are provided in the circumferential surface of the piston 11 at a location excluding the twelve o'clock position, the three o'clock position, the six o'clock position, and the nine o'clock position. The grooves 44 are identical to the grooves 44 described in the second embodiment. The piston 11 is formed, for example, by welding the opened end of a tubular body, which has a bottom wall, with a separate member. The advantageous effects of the second embodiment are also obtained in the third modified form.

(1) In each of the above embodiments, the number, length, depth, and, width of the second groove 17 and the grooves 44, 46 may be altered as required.

(2) In the first embodiment and each of the modified forms of the first embodiment, the depths of the first and second grooves 16, 17 are determined so as to minimize the adhering force produced by the force acting between the molecules of the lubricating oil, and to be within a range that does not degrade the refrigerant gas leakage suppressing function of the lubricating oil. This decreases the sliding resistance between the outer circumferential surface of the piston 11 and the inner circumferential surface of the cylinder bore 2a.

(3) In the second embodiment and each of the modified forms of the second embodiment, the distal end of the grooves 44, 46 may be extended to the rear edge of the piston 11. This constantly connects the grooves 44, 46 with the crank chamber 5.

(4) In the second embodiment and each of the modified forms of the second embodiment, the inner bottom surface at the distal side of the grooves 44, 46 may be formed as a sloped surface that is gradually connected to the circumferential surface of the piston 11. This prevents the distal edge of the grooves 44, 46 from interfering with the edge of the cylinder bore 2a when the piston 11 moves from the bottom dead center to the top dead center.

(5) In the first and second embodiments, the

present invention is embodied in a variable displacement compressor provided with a single headed piston. However, the present invention may also be embodied in, for example, a compressor having a swash plate which inclination is fixed, a double headed piston type compressor, a compressor in which the piston is coupled to a wobble plate by a rod as shown in Fig. 23, and a wave cam type compressor. The wave type compressor is a compressor provided with a wave cam having a wave-like cam surface in lieu of the swash plate.

Claims

1. A piston type compressor comprising a swash plate (9) mounted on a rotary shaft (6) in a crank chamber (5) and a piston (11) accommodated in a cylinder bore (2a), wherein the piston (11) is coupled to the swash plate (9) through a shoe (12), wherein the swash plate (9) converts rotation of the rotary shaft (6) to reciprocation of the piston (11) between a top dead center and a bottom dead center,

said piston (11) having an outer circumferential surface that slides against an inner circumferential surface of the cylinder bore (2a), **characterized in that** the outer circumferential surface is provided with at least one groove (17; 44; 46), extending in the direction of the axis (S) of the piston (11),

wherein an imaginary straight line (M) is defined extending through a center axis (L) of the rotary shaft (6) and the center axis (S) of the piston (11) when viewing the piston (11) so as a rotating direction (R) of the rotary shaft (6) is clockwise, and among the intersecting points (P1, P2) at which the straight line (M) and the outer circumferential surface of the piston (11) intersect, the farther point (P1) from the center axis (L) of the rotary shaft (6) corresponds to a twelve o'clock position, wherein said at least one groove (17; 44; 46) is provided in the circumferential surface of the piston (11) at a position excluding the twelve o'clock position and the six o'clock position.

2. A piston type compressor according to Claim 1, wherein said groove (17; 44; 46) is exposed to the inside of the crank chamber (5) from the cylinder bore (2a) at least when the piston (11) is moved to the bottom dead center so as to draw lubricating oil that exists between the outer circumferential surface of the piston (11) and the inner circumferential surface of the cylinder bore (2a) into the crank chamber (5).

3. A piston type compressor according to Claim 1,

- wherein said groove (17; 44; 46) is always directly connected with the crank chamber (5) to draw the lubricating oil that exists between the outer circumferential surface of the piston (11) and the inner circumferential surface of the cylinder bore (2a) into the crank chamber (5).
4. A piston type compressor according to claim 1, wherein said groove (17; 44; 46) is provided in the circumferential surface of the piston (11) at a position excluding the three o'clock position.
 5. A piston type compressor according to claim 4, wherein said groove (17; 44; 46) is provided in the circumferential surface of the piston (11) within a range (E) extending between nine o'clock and ten thirty.
 6. The compressor piston according to claim 4, wherein said groove (17; 44; 46) is provided in the circumferential surface of the piston (11) within a range (E3) extending between seven thirty and nine o'clock.
 7. A piston type compressor according to claim 1, wherein lubricating oil existing between the outer circumferential surface of said piston (11) and the inner circumferential surface of the cylinder bore (2a) suppresses leakage of refrigerant gas from the cylinder bore (2a) to the crank chamber (5) through the space between the outer circumferential surface of the piston (11) and the inner circumferential surface of the cylinder bore, (2a) while also producing an adhering force between the outer circumferential surface of the piston (11) and the inner circumferential surface of the cylinder bore (2a), wherein the depth of said groove (17; 44; 46) is set so as to minimize said adhering force within a range that does not degrade the refrigerant gas leakage suppressing function of the lubricating oil.
 8. A piston type compressor according to claim 1, wherein said piston (11) is hollow.
 9. A piston type compressor according to claim 2, wherein an inner bottom surface at the distal end of the groove (17; 44; 46) is formed as a sloped surface gradually connected to the outer circumferential surface of the piston (11).
 10. A piston type compressor according to claim 1, wherein the outer circumferential surface of said piston (11) is further provided with a recovering means (16) for collecting lubricating oil adhered to the inner circumferential surface of the cylinder bore (2a) at a position that is constantly unexposed from the inside of the cylinder bore (2a), the lubricating oil in the recovering means (16) being drawn into the crank chamber (5) by means of a groove (17) extending in the direction of the axis (S) of the piston (11).
 11. A piston type compressor according to claim 10, wherein said recovering means is a recovering groove (17) defined in the outer circumferential surface of the piston (11).
 12. A piston type compressor according to claim 11, wherein said recovering groove (17) extends in a circumferential direction of the piston (11).
 13. A piston type compressor according to claim 12, wherein said recovering groove (17) is annular.
 14. A piston type compressor according to claim 11, wherein the groove (17) extending in the direction of the axis (S) of the piston (11) is separated from the recovering groove (16), and wherein both grooves (16), (17) are communicated to each other through a narrow clearance (K) defined between the outer circumferential surface of the piston (11) and the inner circumferential surface of the cylinder bore (2a).
 15. A piston type compressor according to claim 1, wherein the groove (17) extending in the direction of the axis (S) of the piston (11) is connected to the recovering groove (16).
 16. A piston type compressor according to claim 1, comprising a housing (1, 2, 3) provided with the cylinder bore (2a) and the crank chamber (5), the rotary shaft (6) rotatably supported in the housing (1, 2, 3), the swash plate (9) mounted on the rotary shaft (6) in the crank chamber (5), and the piston (11).
 17. The piston type compressor according to claim 1, wherein the groove (17) is defined in the inner circumferential surface of the cylinder bore (2a) either in lieu of the outer circumferential surface of the piston (11) or in addition to the outer circumferential surface of the piston (11).
 18. The piston type compressor according to claim 1, wherein said piston is a single-headed piston (11) provided with a head on one of its ends.
 19. The piston type compressor according to claim 1, wherein said piston is a single-headed piston (11) provided with a head on one of its ends, wherein said swash plate (9) alters its inclining angle with respect to the rotary shaft (6) in accordance with the difference in the pressure in the crank chamber (5) and the pressure in a suction chamber (3a), wherein the inclining angle of the swash plate (9) alters the

moving stroke of the piston (11) to adjust displacement.

Patentansprüche

1. Kolbenkompressor mit einer Taumelscheibe (9), die auf einer Drehwelle (6) in einer Kurbelkammer (5) montiert ist, und einem Kolben (11), der in einer Zylinderbohrung (2a) untergebracht ist, wobei der Kolben (11) mit der Taumelscheibe (9) über einen Schuh (12) gekoppelt ist, wobei die Taumelscheibe (9) die Drehung der Drehwelle (6) in eine Hin- und Herbewegung des Kolbens (11) zwischen einem oberen Totpunkt und unteren Totpunkt umwandelt, wobei der Kolben (11) eine Außenumfangsfläche hat, die an einer Innenumfangsfläche der Zylinderbohrung (2a) gleitet,

dadurch gekennzeichnet, dass

die Außenumfangsfläche zumindest mit einer Nut (17; 44; 46) versehen ist, die sich in der Richtung der Achse (S) des Kolbens (11) erstreckt,

wobei eine imaginäre gerade Linie (M) definiert ist, die sich durch eine Mittelachse (L) der Drehwelle (6) und die Mittelachse (S) des Kolbens (11) erstreckt, wenn der Kolben (11) so betrachtet wird, dass eine Drehrichtung (R) der Drehwelle (6) im Uhrzeigersinn ist und wobei von den Schnittpunkten (P1, P2), bei denen die gerade Linie (M) und die Außenumfangsfläche des Kolbens (11) sich schneiden, der von der Mittelachse (L) der Drehwelle (6) entferntere Punkt (P1) einer Zwölf-Uhr-Position entspricht, wobei die zumindest eine Nut (17; 44; 46) in der Umfangsfläche des Kolbens (11) bei einer Position außer der Zwölf-Uhr-Position und der Sechs-Uhr-Position vorgesehen ist.

2. Kolbenkompressor nach Anspruch 1, wobei die Nut (17; 44; 46) dem Inneren der Kurbelkammer (5) von der Zylinderbohrung (2a) zumindest dann ausgesetzt ist, wenn der Kolben (11) zu dem unteren Totpunkt bewegt wird, um Schmieröl in die Kurbelkammer (5) einzusaugen, das zwischen der Außenumfangsfläche des Kolbens (11) und der Innenumfangsfläche der Zylinderbohrung (2a) vorhanden ist.
3. Kolbenkompressor nach Anspruch 1, wobei die Nut (17; 44; 46) immer unmittelbar mit der Kurbelkammer (5) verbunden ist, um das Schmieröl in die Kurbelkammer (5) hinein anzusaugen, das zwischen der Außenumfangsfläche des Kolbens (11) und der Innenumfangsfläche der Zylinderbohrung (2a) vorhanden ist.

4. Kolbenkompressor nach Anspruch 1, wobei die Nut (17; 44; 46) in der Umfangsfläche des Kolbens (11) bei einer Position außer der Drei-Uhr-Position vorgesehen ist.

5. Kolbenkompressor nach Anspruch 4, wobei die Nut (17; 44; 46) in der Umfangsfläche des Kolbens (11) innerhalb eines Bereichs (E) vorgesehen ist, der sich erstreckt zwischen der Neun-Uhr-Position und der Zehn-Uhr-Dreißig-Position.

6. Kolbenkompressor nach Anspruch 4, wobei die Nut (17; 44; 46) in der Umfangsfläche des Kolbens (11) innerhalb eines Bereichs (E3) vorgesehen ist, der sich erstreckt zwischen der Sieben-Uhr-Dreißig- und der Neun-Uhr-Position.

7. Kolbenkompressor nach Anspruch 1, wobei Schmieröl, das zwischen Außenumfangsfläche des Kolbens (11) und der Innenumfangsfläche der Zylinderbohrung (2a) vorhanden ist, ein Leck des Kühlgases aus der Zylinderbohrung (2a) in die Kurbelkammer (5) durch den Raum zwischen der Außenumfangsfläche des Kolbens (11) und der Innenumfangsfläche der Zylinderbohrung (2a) unterdrückt, während auch eine Haftkraft erzeugt wird zwischen der Außenumfangsfläche des Kolbens (11) und der Innenumfangsfläche der Zylinderbohrung (2a), wobei die Tiefe der Nut (17; 44, 46) so eingerichtet ist, dass die Haftkraft innerhalb eines Bereichs minimiert wird, der die Kühlgasleckageunterdrückungswirkung des Schmieröls nicht verschlechtert.

8. Kolbenkompressor nach Anspruch 1, wobei der Kolben (11) hohl ist.

9. Kolbenkompressor nach Anspruch 3, wobei eine innere Bodenfläche bei dem fernen Ende der Nut (17; 15; 44; 46) als eine geneigte Fläche ausgebildet ist, die graduell mit der Außenumfangsfläche des Kolbens (11) verbunden ist.

10. Kolbenkompressor nach Anspruch 1, wobei die Außenumfangsfläche des Kolbens (11) des weiteren mit einer Wiederherstelleinrichtung (16) versehen ist zum Sammeln von Schmieröl, das an der Innenumfangsfläche der Zylinderbohrung (2a) bei einer Position haftet, die konstant von dem Inneren der Zylinderbohrung (2a) nicht ausgesetzt ist, wobei das Schmieröl aus der Wiederherstelleinrichtung (16) in die Kurbelkammer (5) hineingesaugt wird mittels einer Nut (17), die sich in der Richtung der Achse (S) des Kolbens (11) erstreckt.

11. Kolbenkompressor nach Anspruch 10, wobei die Wiederherstelleinrichtung eine Wiederherstellnut (17) ist, die in der Außenumfangsfläche des Kol-

bens (11) definiert ist.

12. Kolbenkompressor nach Anspruch 11, wobei die Wiederherstellnut (17) sich in einer Umfangsrichtung des Kolbens (11) erstreckt. 5
13. Kolbenkompressor nach Anspruch 12, wobei die Wiederherstellnut (17) ringförmig ist.
14. Kolbenkompressor nach Anspruch 11, wobei die Nut (17), die sich in der Richtung der Achse (S) des Kolbens (11) erstreckt, von der Wiederherstellnut (16) getrennt ist, und wobei beiden Nuten (16), (17) miteinander verbunden sind über ein enges Spiel (K), das definiert ist zwischen der Außenumfangsfläche des Kolbens (11) und der Innenumfangsfläche der Zylinderbohrung (2a). 10
15. Kolbenkompressor nach Anspruch 1, wobei die Nut (17), die sich in der Richtung der Achse (S) des Kolbens (11) erstreckt, mit der Wiederherstellnut (16) verbunden ist. 20
16. Kolbenkompressor nach Anspruch 1, der ein Gehäuse (1, 2, 3) aufweist, das mit der Zylinderbohrung (2a) und der Kurbelkammer (5) versehen ist, wobei die Drehwelle (6) in dem Gehäuse (1, 2, 3) drehbar gelagert ist, wobei die Taumelscheibe (9) an der Drehwelle (6) in der Kurbelkammer (5) und dem Kolben (11) montiert ist. 25
17. Kolbenkompressor nach Anspruch 1, wobei die Nut (17) in der Innenumfangsfläche der Zylinderbohrung (2a) entweder anstelle der Außenumfangsfläche des Kolbens (11) oder zusätzlich zu der Außenumfangsfläche des Kolbens (11) definiert ist. 30
18. Kolbenkompressor nach Anspruch 1, wobei der Kolben ein einfach wirkender Kolben (11) ist, der mit einem Kopf an einem seiner Enden versehen ist. 40
19. Kolbenkompressor nach Anspruch 1, wobei der Kolben ein einfach wirkender Kolben (11) ist, der mit einem Kopf an einem seiner Enden versehen ist, wobei die Taumelscheibe (9) ihren Neigungswinkel bezüglich der Drehwelle (6) ändert, in Übereinstimmung mit der Druckdifferenz in der Kurbelkammer (5) und einer Ansaugkammer (3a), wobei der Neigungswinkel der Taumelscheibe (9) den Bewegungshub des Kolbens (11) ändert, um den Hubraum einzustellen. 45

Revendications 55

1. Compresseur du type à piston comprenant un disque en nutation (9) monté sur un arbre rotatif (6)

dans une chambre de bielle (5) et un piston (11) logé dans un alésage cylindrique (2a), dans lequel le piston (11) est couplé au disque en nutation (9) par l'intermédiaire d'un patin (12), dans lequel le disque en nutation (9) convertit la rotation de l'arbre rotatif (6) en un mouvement alternatif du piston (11) entre un point mort haut et un point mort bas,

ledit piston (11) présentant une surface de circonférence extérieure qui glisse contre une surface de circonférence intérieure de l'alésage cylindrique (2a), **caractérisé en ce que** la surface de circonférence extérieure est munie d'au moins une rainure (17 ; 44 ; 46) qui s'étend dans la direction de l'axe (S) du piston (11),

dans lequel une ligne droite imaginaire (M) est définie comme s'étendant à travers un axe central (L) de l'arbre rotatif (6) et de l'axe central (S) du piston (11) lorsqu'on regarde le piston (11), de façon qu'une direction de rotation (R) de l'arbre rotatif (6) soit le sens des aiguilles d'une montre, et parmi les points d'intersection (P1, P2) auxquels la ligne droite (M) et la surface de circonférence extérieure du piston (11) se coupent, le point le plus éloigné (P1) à partir de l'axe central (L) de l'arbre rotatif (6) correspond à la position douze heures, dans lequel ladite au moins une rainure (17 ; 44 ; 46) est fournie dans la surface de circonférence du piston (11) en une position excluant la position douze heures et la position six heures.

2. Compresseur de type à piston selon la revendication 1, dans lequel ladite rainure (17 ; 44 ; 46) est exposée à l'intérieur de la chambre de bielle (5) à partir de l'alésage cylindrique (2a) au moins lorsque le piston (11) se déplace vers le point mort bas, de façon à aspirer l'huile lubrifiante qui existe entre la surface de circonférence extérieure du piston (11) et la surface de circonférence intérieure de l'alésage cylindrique (2a) dans la chambre de bielle (5).
3. Compresseur de type à piston selon la revendication 1, dans lequel ladite rainure (17 ; 44 ; 46) est toujours directement raccordée à la chambre de bielle (5) pour aspirer l'huile lubrifiante qui existe entre la surface de circonférence extérieure du piston (11) et la surface de circonférence intérieure de l'alésage cylindrique (2a) dans la chambre de bielle (5).
4. Compresseur de type à piston selon la revendication 1, dans lequel ladite rainure (17 ; 44 ; 46) est fournie dans la surface de circonférence extérieure du piston (11) en une position excluant la position trois heures.

5. Compresseur de type à piston selon la revendication 4, dans lequel ladite rainure (17 ; 44 ; 46) est fournie dans la surface de circonférence extérieure du piston (11) dans un intervalle (E) qui s'étend entre les positions neuf heures et dix heures et demie. 5
6. Compresseur de type à piston selon la revendication 4, dans lequel ladite rainure (17 ; 44 ; 46) est fournie dans la surface de circonférence extérieure du piston (11) dans un intervalle (E3) qui s'étend entre les positions sept heures et demie et neuf heures. 10
7. Compresseur de type à piston selon la revendication 1, dans lequel l'huile lubrifiante existant entre la surface de circonférence extérieure dudit piston (11) et la surface de circonférence intérieure de l'alésage cylindrique (2a) supprime la fuite du gaz réfrigérant entre l'alésage cylindrique (2a) et la chambre de bielle (5) à travers l'espace situé entre la surface de circonférence extérieure du piston (11) et la surface de circonférence intérieure de l'alésage cylindrique (2a), tout en produisant également une force d'adhésion entre la surface de circonférence extérieure du piston (11) et la surface de circonférence intérieure de l'alésage cylindrique (2a), dans lequel la profondeur de ladite rainure (17 ; 44 ; 46) est fixée de manière à réduire au minimum ladite force d'adhésion à l'intérieur d'un intervalle qui ne dégrade pas la fonction de suppression de la fuite de gaz réfrigérant de l'huile lubrifiante. 20 25 30
8. Compresseur de type à piston selon la revendication 1, dans lequel ledit piston (11) est creux. 35
9. Compresseur de type à piston selon la revendication 2, dans lequel une surface inférieure intérieure au niveau de l'extrémité distale de la rainure 17 ; 15 ; 44 ; 46) est formée comme une surface pentue raccordée progressivement à la surface de circonférence extérieure du piston (11). 40
10. Compresseur de type à piston selon la revendication 1, dans lequel la surface de circonférence extérieure dudit piston (11) est en outre munie d'un moyen de récupération (16) permettant de récupérer l'huile lubrifiante qui adhère à la surface de circonférence intérieure de l'alésage cylindrique (2a) en une position qui est, de manière constante, non-exposée à partir de l'intérieur de l'alésage cylindrique (2a), l'huile lubrifiante dans le moyen de récupération (16) étant aspirée dans la chambre de bielle (5) au moyen d'une rainure (17) qui s'étend dans la direction de l'axe (S) du piston (11). 45 50 55
11. Compresseur de type à piston selon la revendication 10, dans lequel ledit moyen de récupération est une rainure de récupération (17) définie dans la surface de circonférence extérieure du piston (11).
12. Compresseur de type à piston selon la revendication 11, dans lequel ladite rainure de récupération (17) s'étend dans une direction de circonférence du piston (11).
13. Compresseur de type à piston selon la revendication 12, dans lequel ladite rainure de récupération (17) est annulaire.
14. Compresseur de type à piston selon la revendication 11, dans lequel la rainure (17) qui s'étend dans la direction de l'axe (S) du piston (11) est séparée de la rainure de la récupération (16), et dans lequel les deux rainures (16), (17) communiquent l'une avec l'autre par l'intermédiaire d'un jeu étroit (K) défini entre la surface de circonférence extérieure du piston (11) et la surface de circonférence intérieure de l'alésage cylindrique (2a).
15. Compresseur de type à piston selon la revendication 1, dans lequel la rainure (17) qui s'étend dans la direction de l'axe (S) du piston (11) est raccordée à la rainure de récupération (16).
16. Compresseur de type à piston selon la revendication 1, comprenant un boîtier (1, 2, 3) muni de l'alésage cylindrique (2a) et de la chambre de bielle (5), de l'arbre rotatif (6) supporté, pour tourner par le boîtier (1, 2, 3), du disque en nutation (9) monté sur l'arbre rotatif (6) dans la chambre de bielle (5), et du piston (11).
17. Compresseur de type à piston selon la revendication 1, dans lequel la rainure (17) est définie dans la surface de circonférence de l'alésage cylindrique (2a) soit à la place de la surface de circonférence extérieure du piston (11), soit en plus de la surface de circonférence extérieure du piston (11).
18. Compresseur de type à piston selon la revendication 1, dans lequel ledit piston est un piston à tête unique (11) munie d'une tête sur l'une de ses extrémités.
19. Compresseur de type à piston selon la revendication 1, dans lequel ledit piston est un piston à tête unique (11) munie d'une tête sur l'une de ses extrémités, dans lequel ledit disque en nutation (9) modifie son angle d'inclinaison par rapport à l'arbre rotatif (6) en fonction de la différence de pression dans la chambre de bielle (5) et de la pression dans une chambre d'aspiration (3a), dans lequel l'angle d'inclinaison du disque en nutation (9) modifie la course du mouvement du piston (11) pour régler le déplacement.

Fig.2

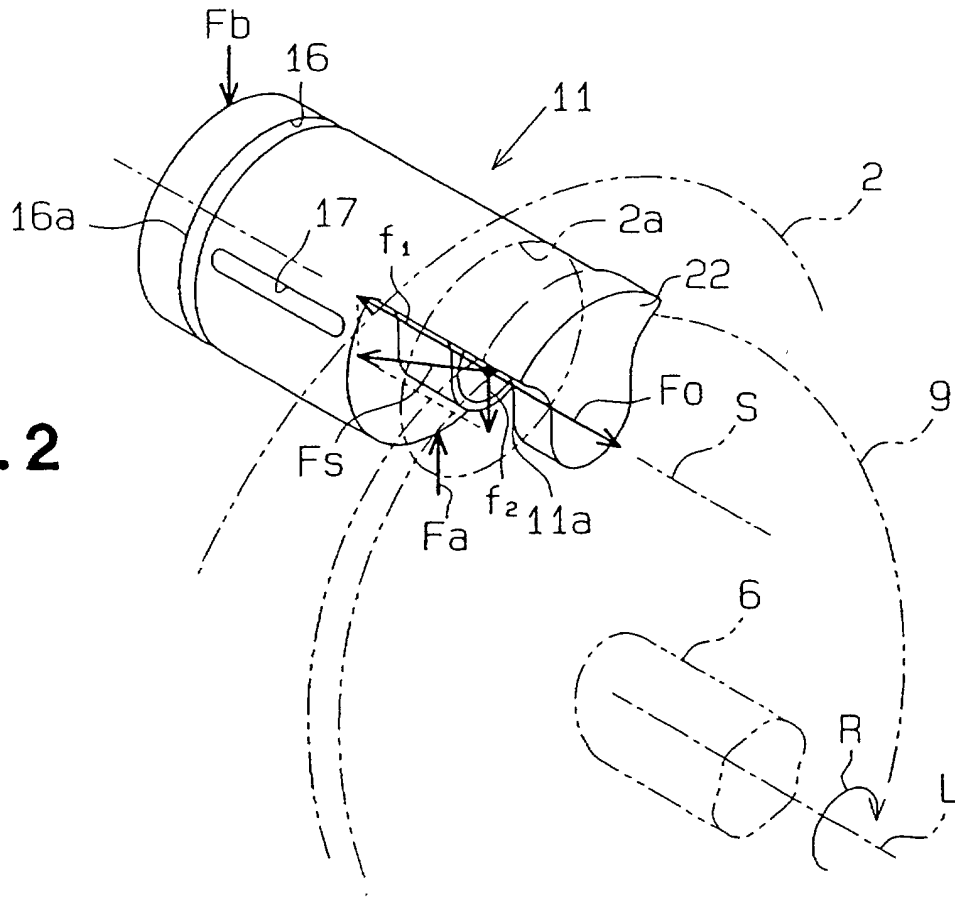

Fig.3

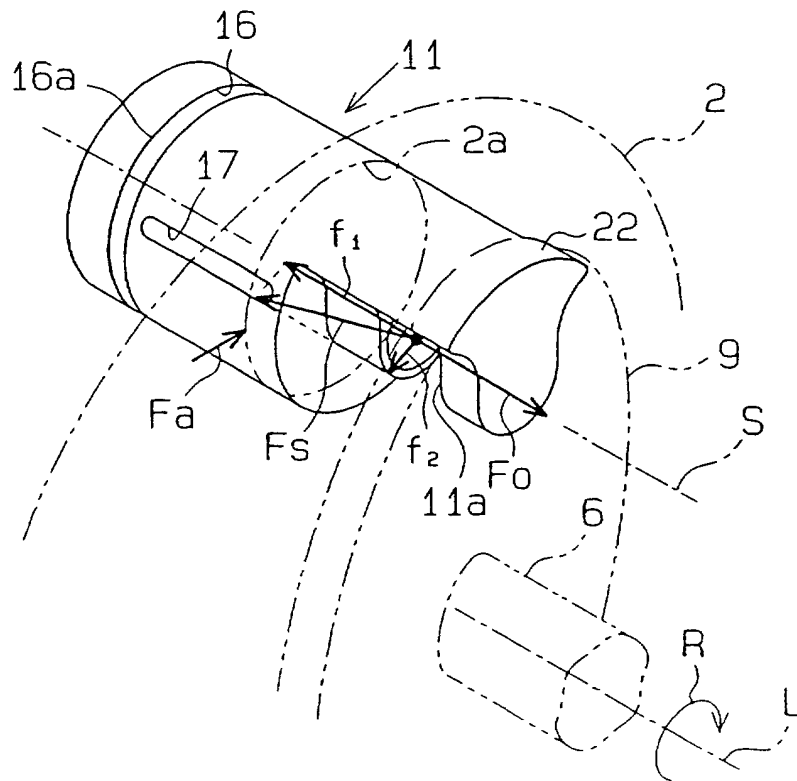

Fig.4

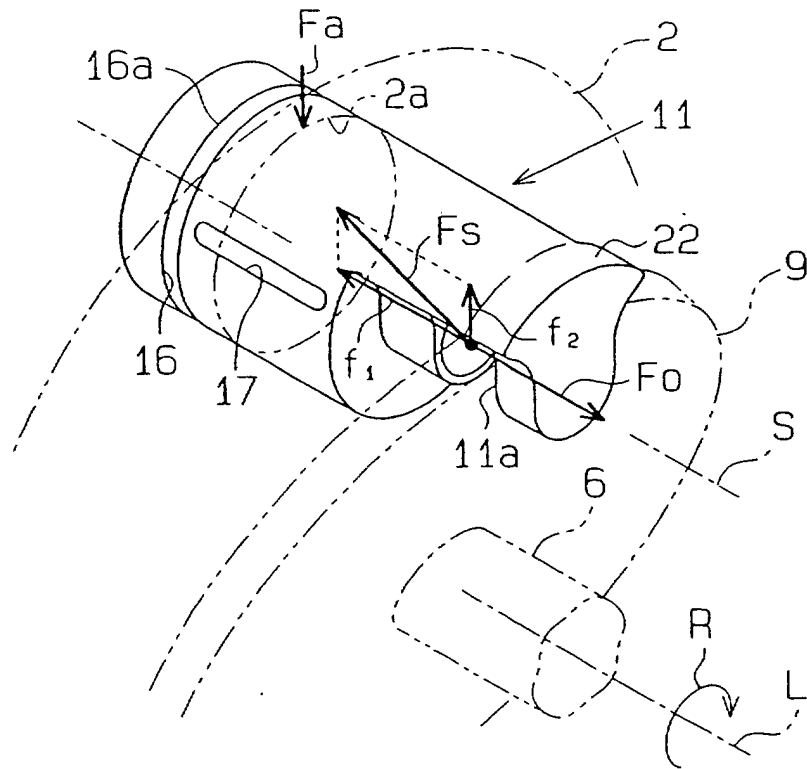

Fig.5

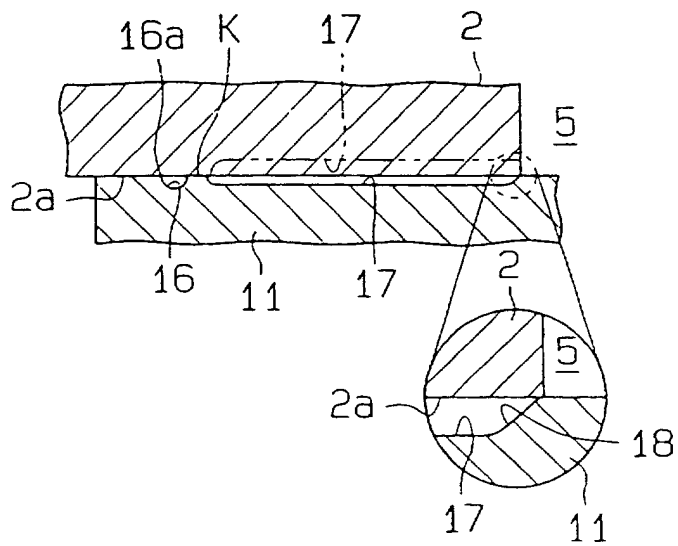

Fig. 6 (a)

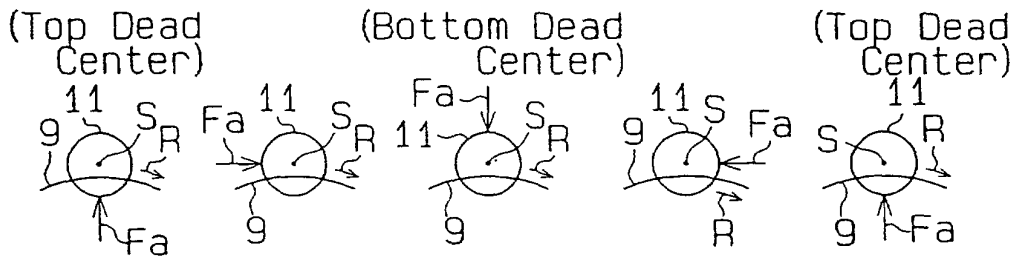
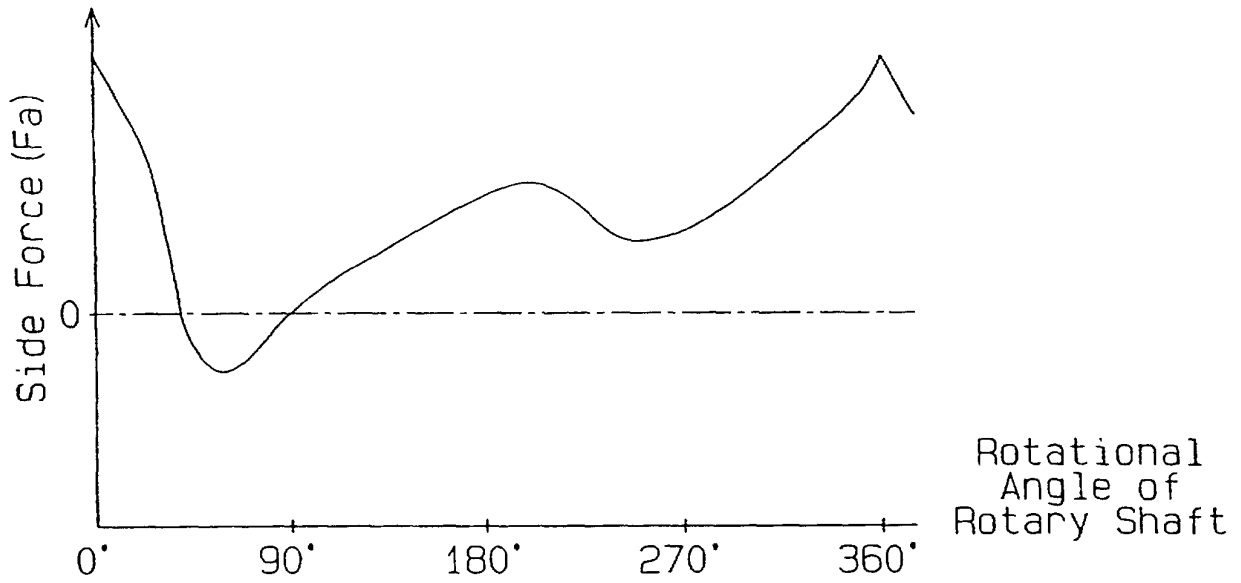

Fig. 6 (b)

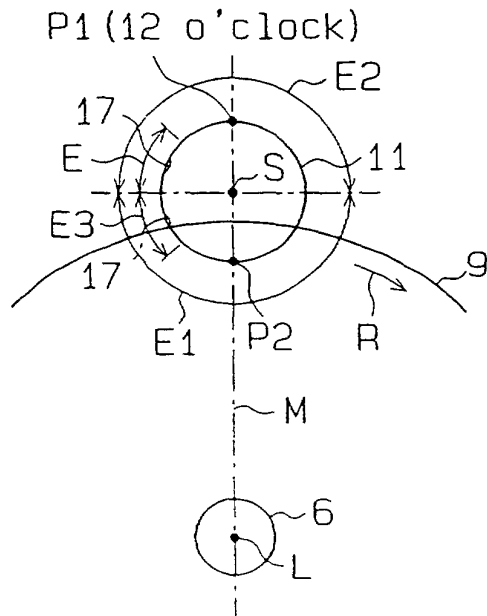

Fig.7

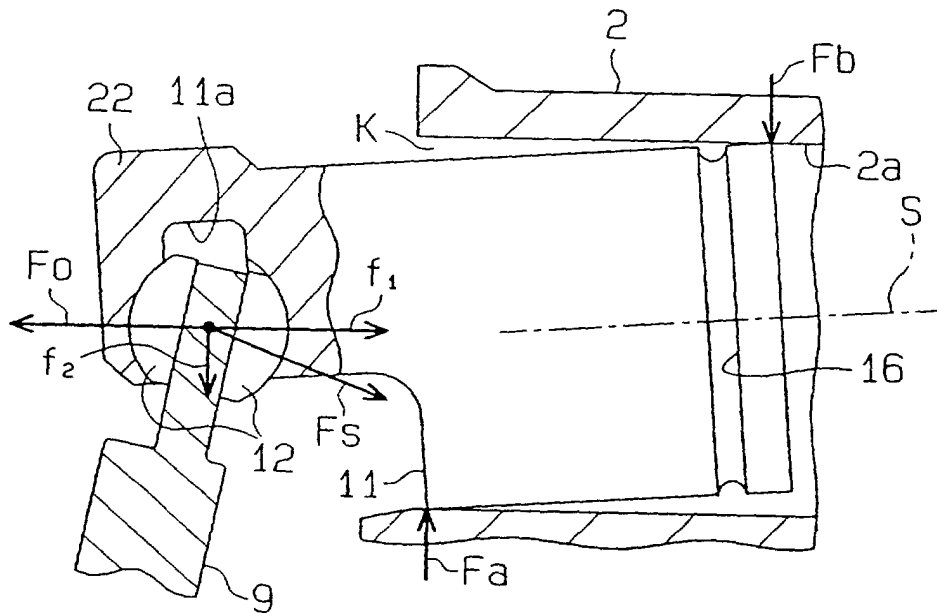

Fig.8

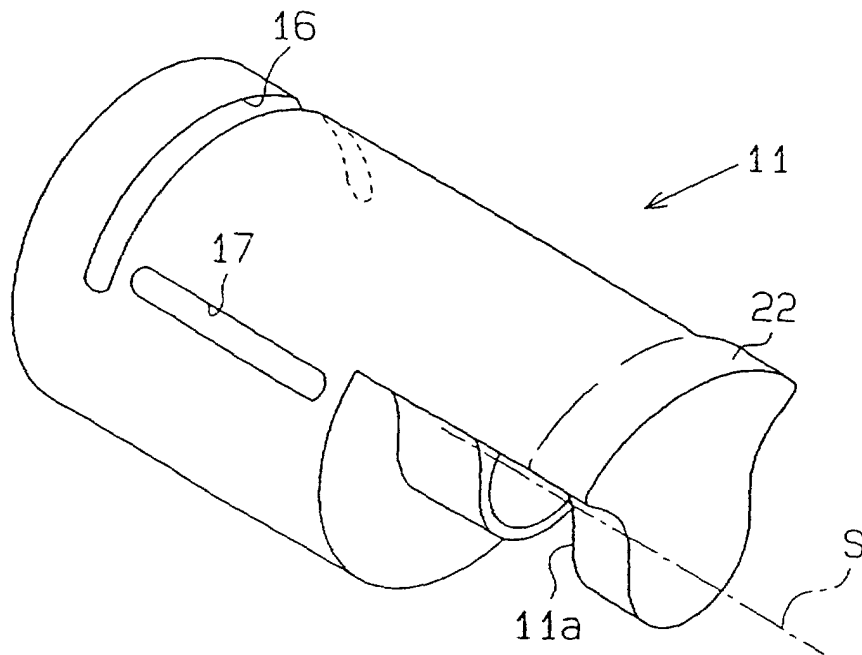

Fig. 9

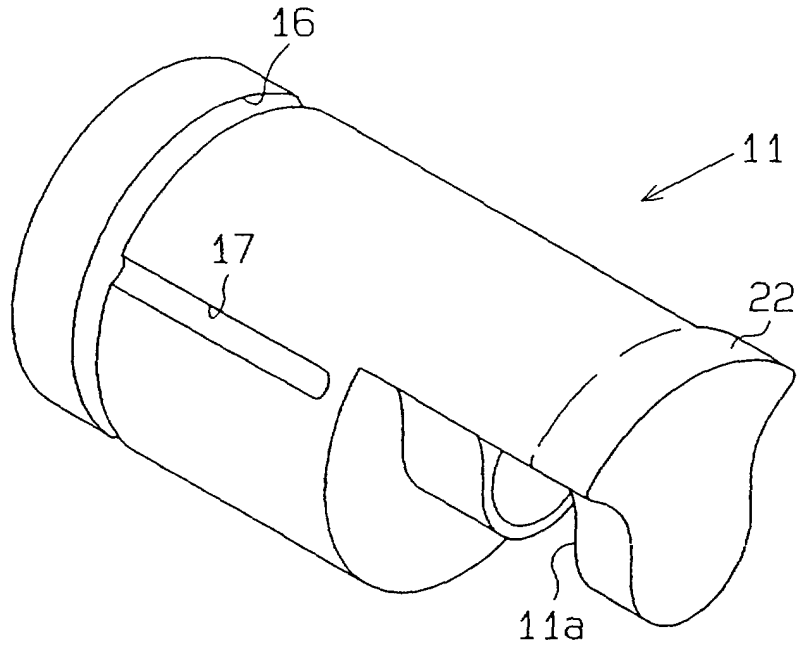

Fig. 10

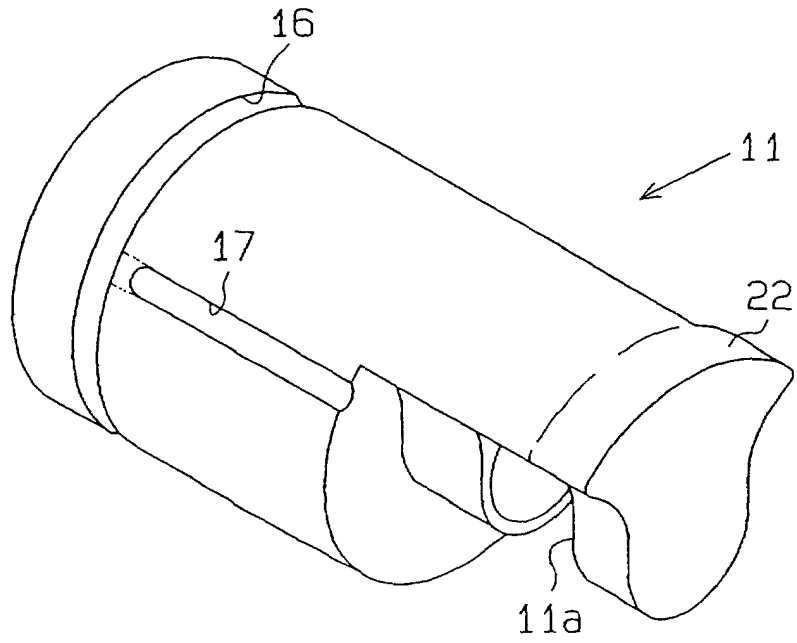

Fig.11 (a)

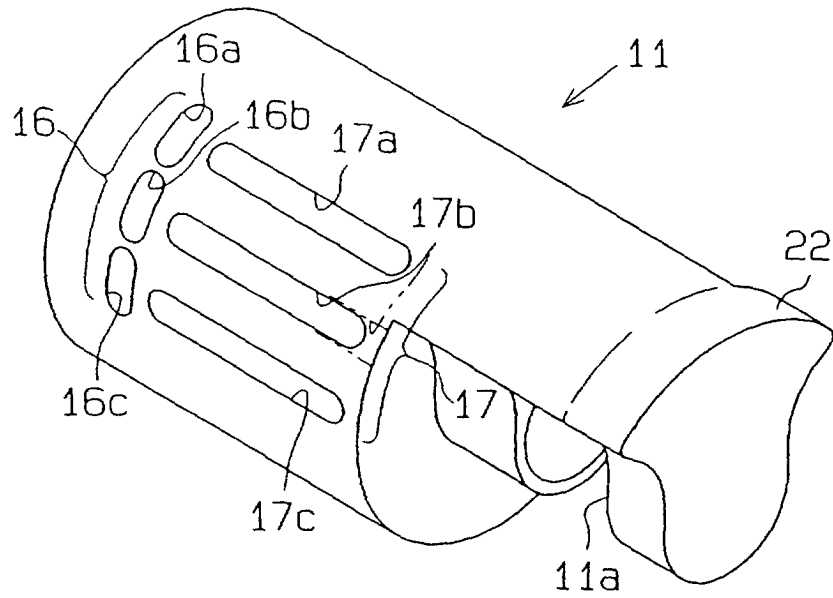

Fig.11 (b)

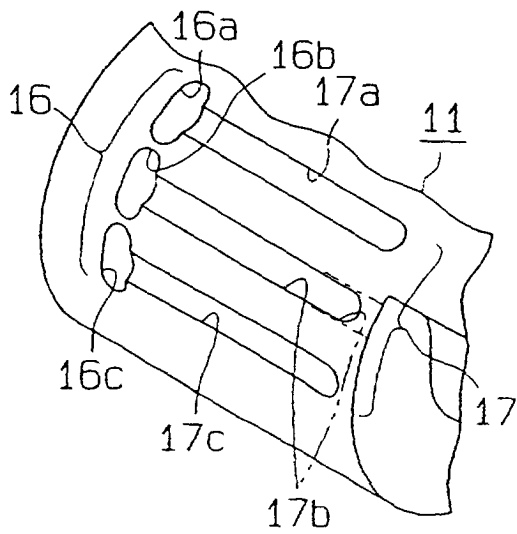

Fig.11 (c)

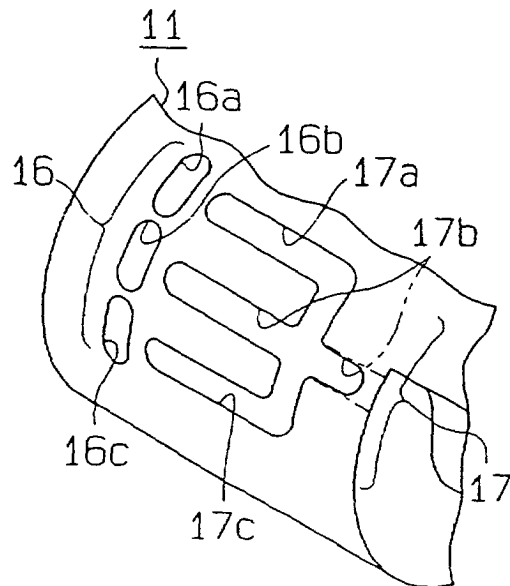

Fig. 12

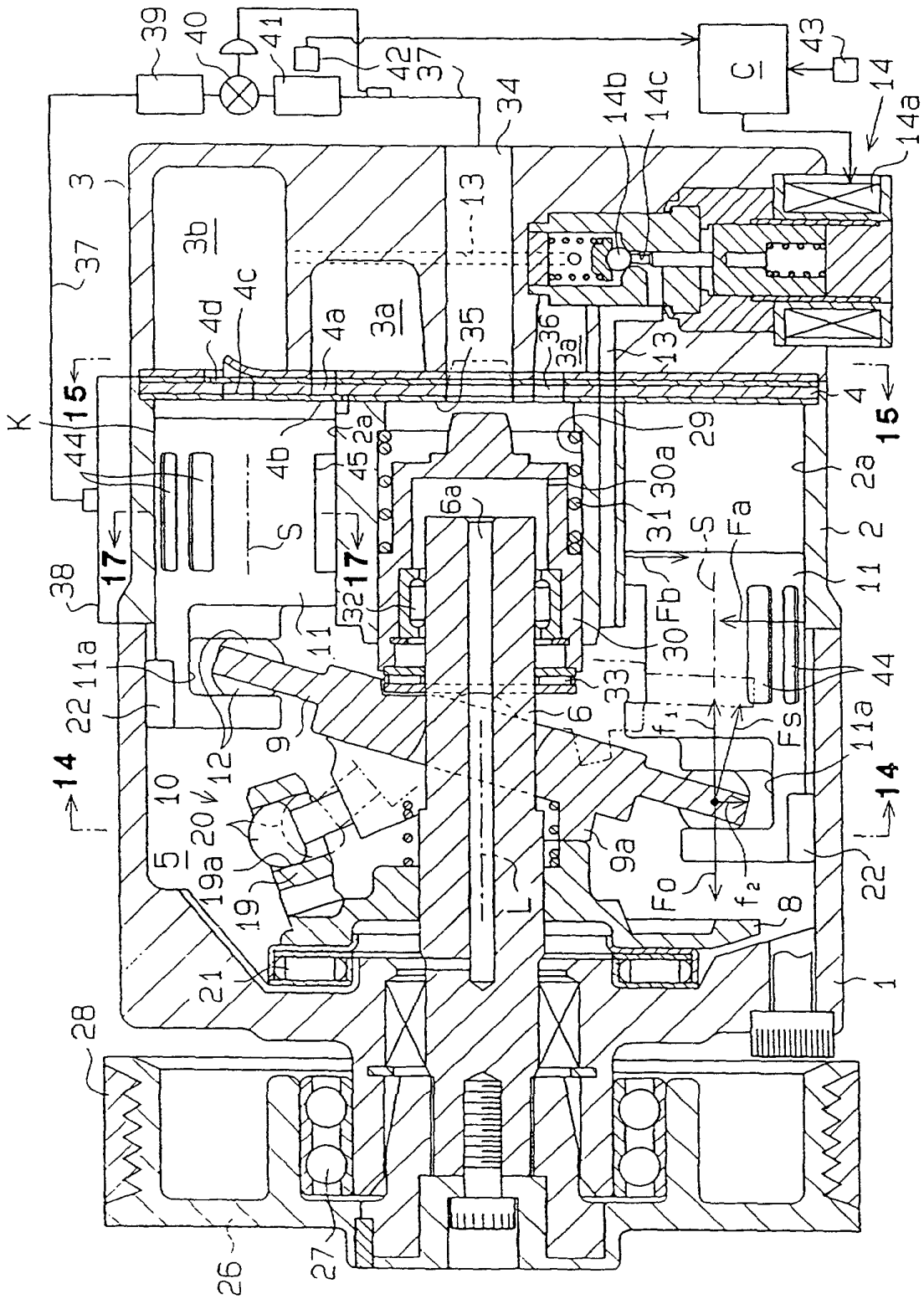

Fig.13

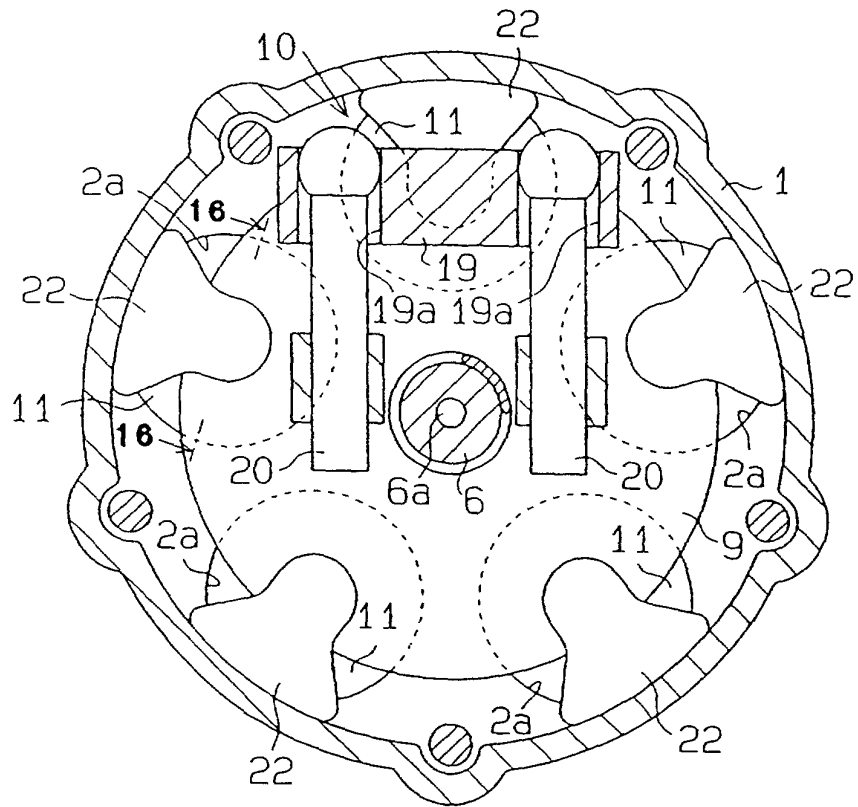

Fig.14

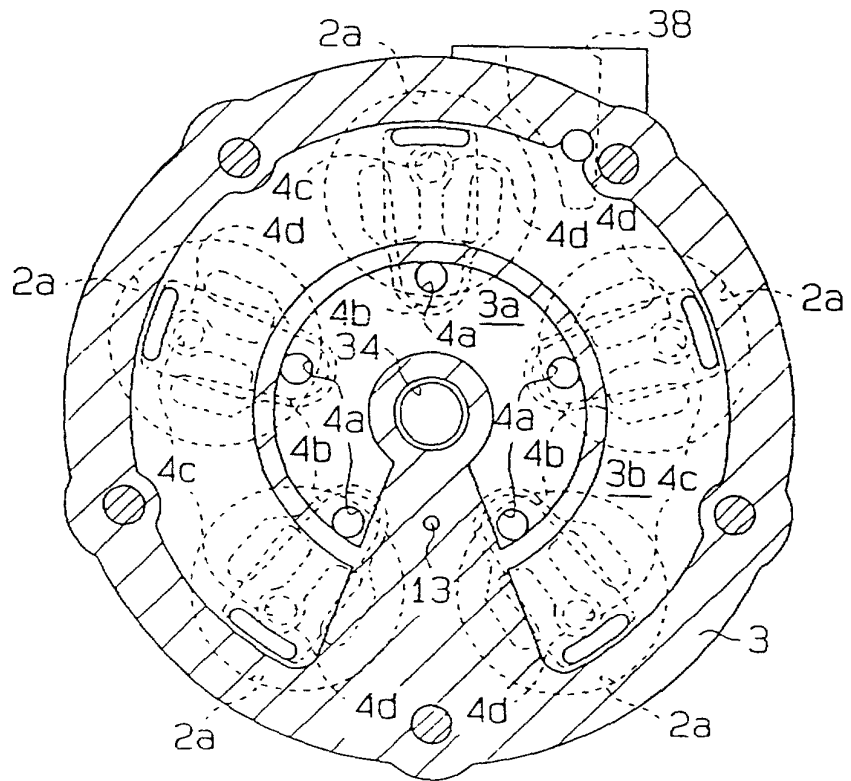

Fig.15

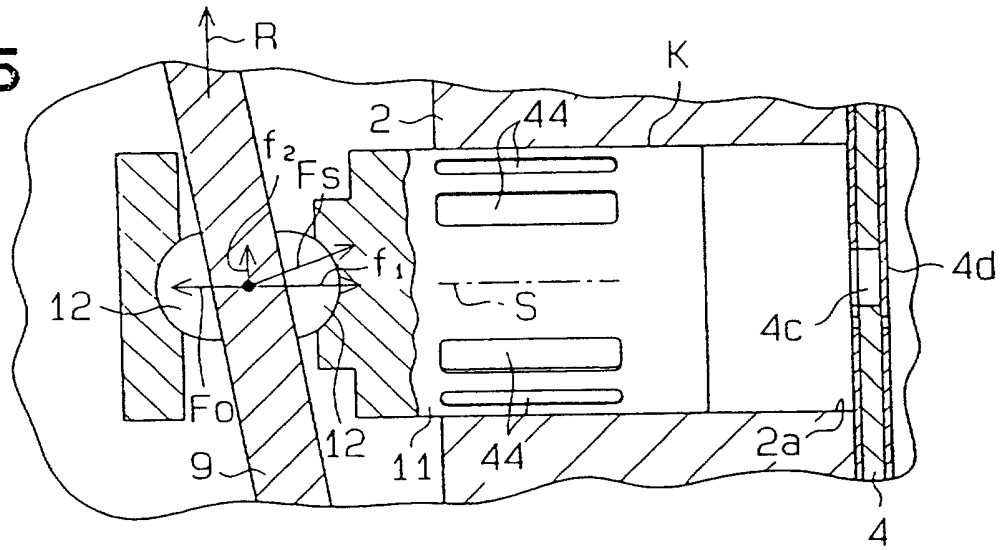

Fig.16

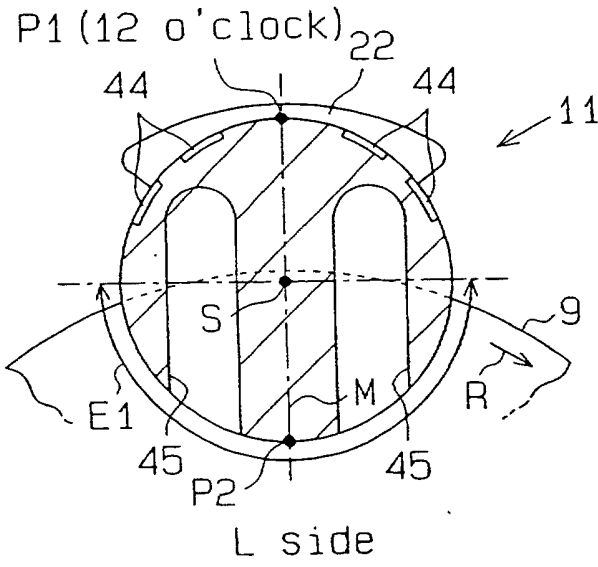

Fig.17

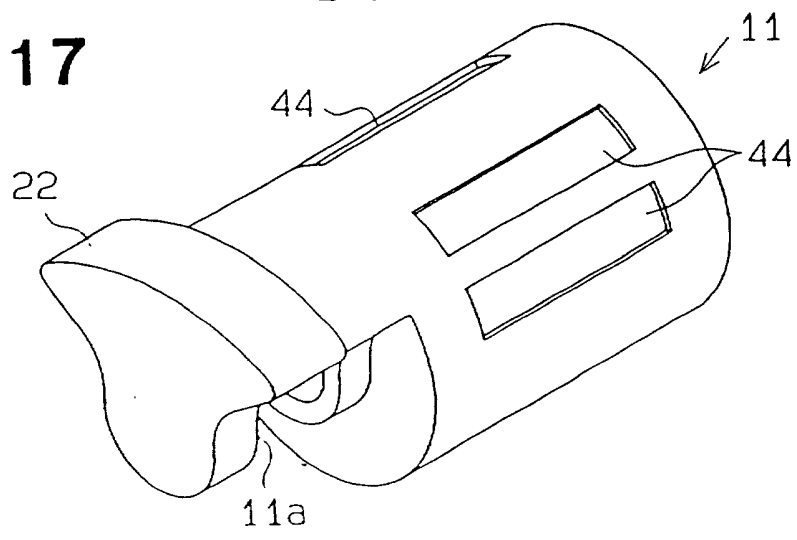

Fig.18

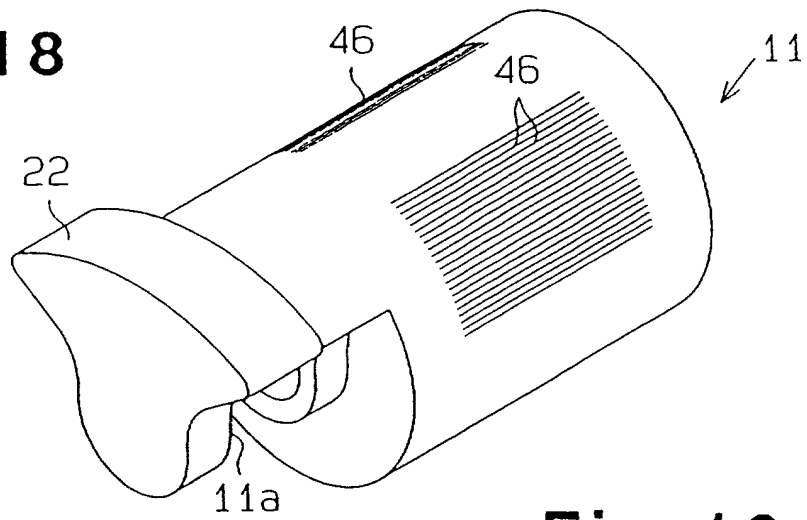

Fig.19

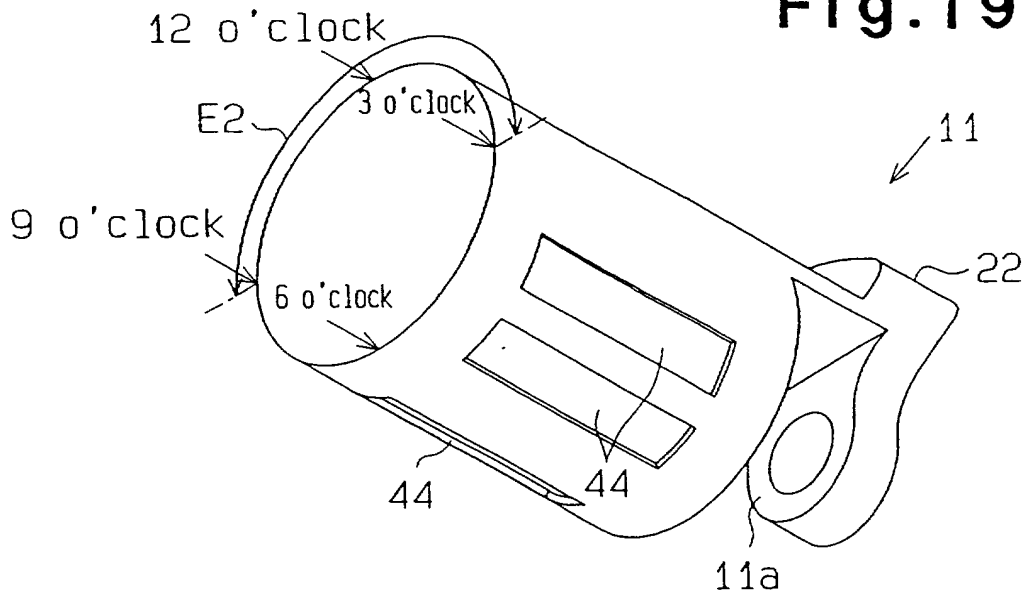

Fig.20

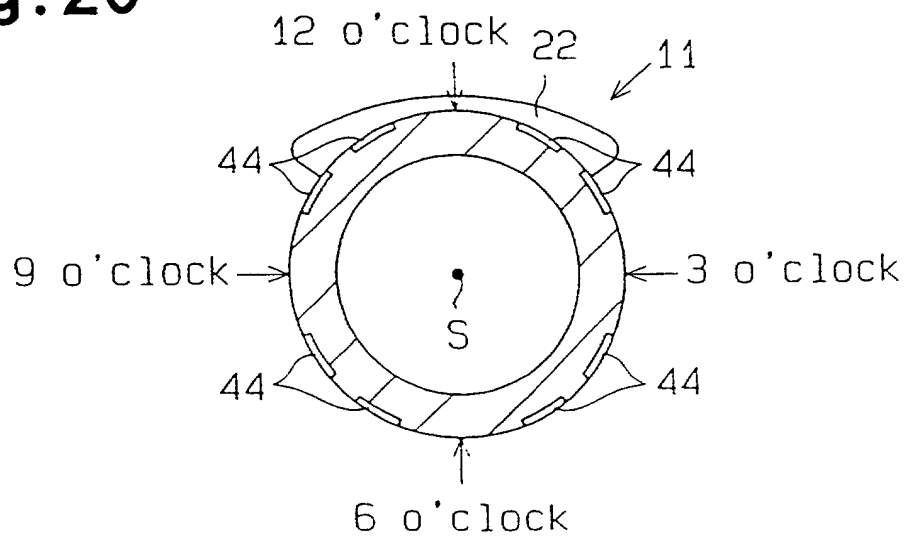

Fig. 21

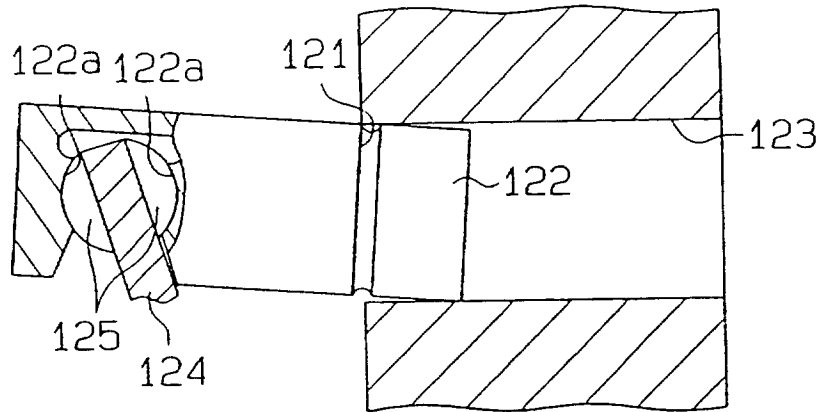

Fig. 22

