



US006931196B2

(12) **United States Patent**
Livas et al.

(10) **Patent No.:** US 6,931,196 B2
(45) **Date of Patent:** *Aug. 16, 2005

(54) **OPTICAL DEVICE INCLUDING DYNAMIC CHANNEL EQUALIZATION**

(75) Inventors: **Jeffrey C. Livas**, Millersville, MD (US); **Tomas Brenner**, Severna Park, MD (US)

(73) Assignee: **Ciena Corporation**, Linthicum, MD (US)

(*) Notice: Subject to any disclaimer, the term of this patent is extended or adjusted under 35 U.S.C. 154(b) by 0 days.

This patent is subject to a terminal disclaimer.

(21) Appl. No.: **10/866,825**

(22) Filed: **Jun. 15, 2004**

(65) **Prior Publication Data**

US 2004/0228602 A1 Nov. 18, 2004

Related U.S. Application Data

(62) Division of application No. 09/493,313, filed on Jan. 28, 2000, now Pat. No. 6,760,532.

(51) **Int. Cl.**⁷ **G02B 6/00**

(52) **U.S. Cl.** **385/140**; 385/24; 359/337.1; 359/337.11; 398/162

(58) **Field of Search** 385/31, 48, 140, 385/24; 359/337.1, 337.11, 337.12, 337.13, 337.2, 337.21, 337.22; 398/140, 141, 158-160, 162

(56) **References Cited**

U.S. PATENT DOCUMENTS

- 5,392,154 A 2/1995 Chang et al.
- 5,557,439 A 9/1996 Alexander et al.
- 5,815,299 A 9/1998 Bayart et al.
- 5,894,362 A * 4/1999 Onaka et al. 398/95

- 5,900,893 A 5/1999 Ford et al.
- 5,923,450 A 7/1999 Dugan et al.
- 5,963,291 A 10/1999 Wu et al.
- 5,970,201 A 10/1999 Anthony et al.
- 5,974,216 A 10/1999 Nakaya
- 5,986,800 A 11/1999 Kosaka
- 6,091,538 A 7/2000 Takeda et al.
- 6,157,475 A 12/2000 Dugan et al.
- 6,486,984 B1 * 11/2002 Baney et al. 398/212
- 6,567,196 B1 5/2003 Archambault

FOREIGN PATENT DOCUMENTS

- EP 0 637 148 A1 2/1995
- EP 0 762 677 A2 3/1997
- GB 2 294 170 4/1996

* cited by examiner

Primary Examiner—Juliana Kang

(74) *Attorney, Agent, or Firm*—Michael R. Cammarata; David L. Soltz

(57) **ABSTRACT**

An optical device including dynamic channel equalization is provided. In an exemplary multiplexer or line amplifier configuration the device includes a plurality of separate optical paths, each of which receiving a separate group of optical signals. Each group of optical signals is provided to an associated variable optical attenuator. Separate inputs of an optical combiner are each coupled to an output of an associated one of the variable optical attenuators. The optical combiner has an output providing the separate groups of optical signals in an aggregated form on an aggregate optical signal path. An optical performance monitor is coupled to the aggregate optical signal path, and is configured to detect an optical signal to noise ratio of each of the separate groups. The monitor supplied a feedback signal to corresponding ones of the variable optical attenuators for adjusting a respective attenuation associated with each of the attenuators in dependence of the detected optical signal to noise ratios. The device may also be provided in a demultiplexer configuration.

19 Claims, 20 Drawing Sheets

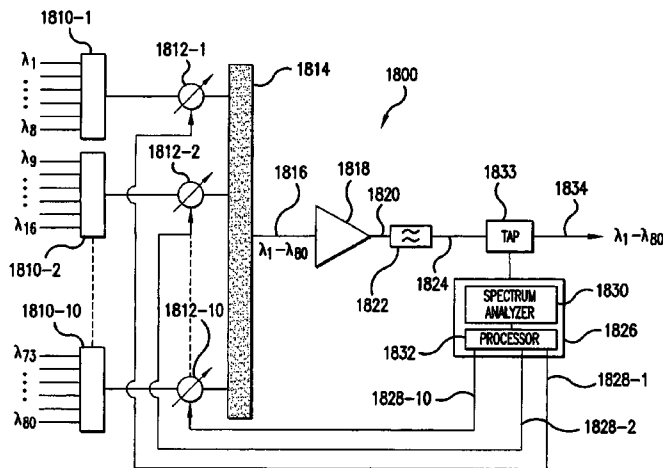

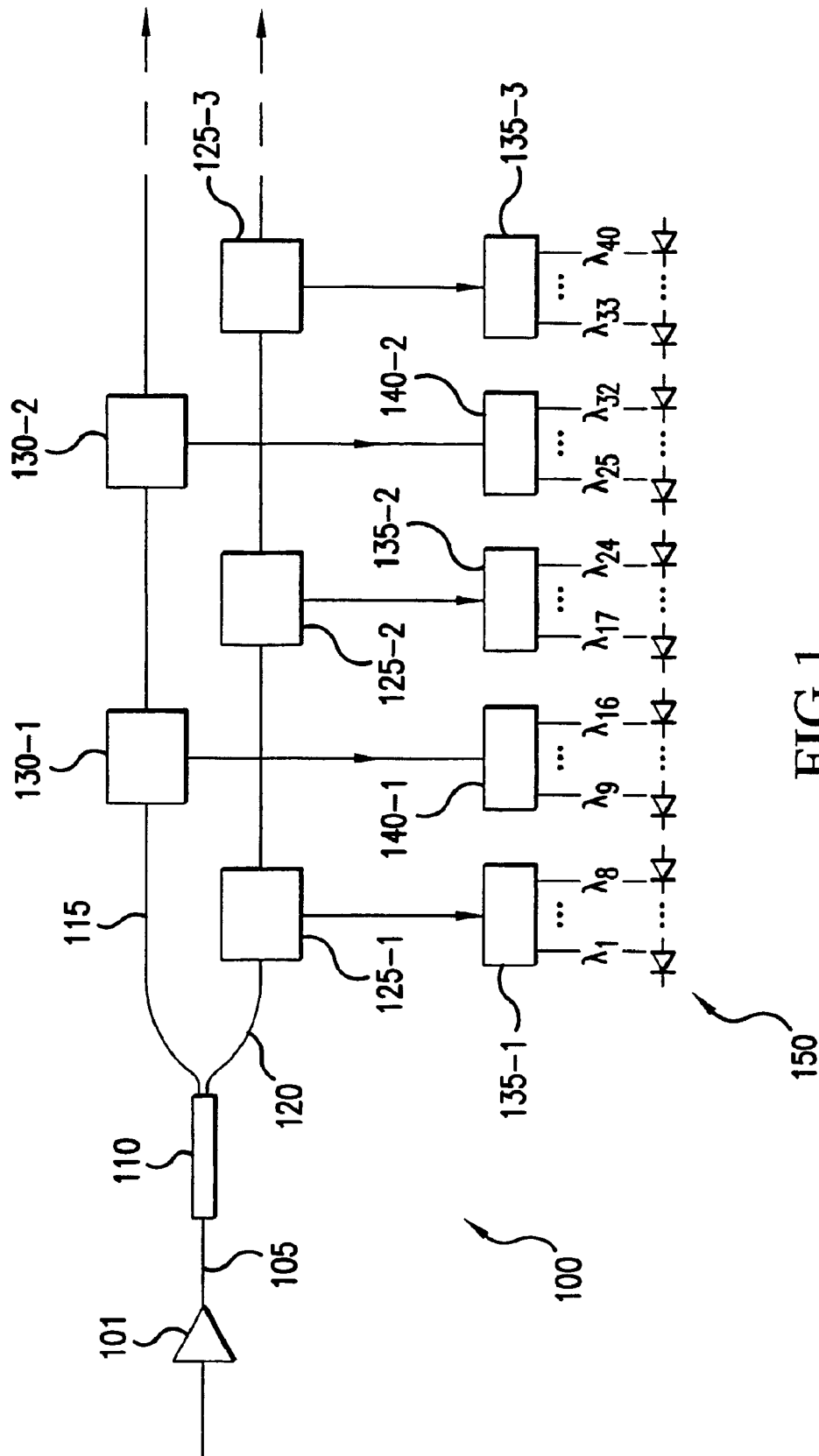

FIG. 1

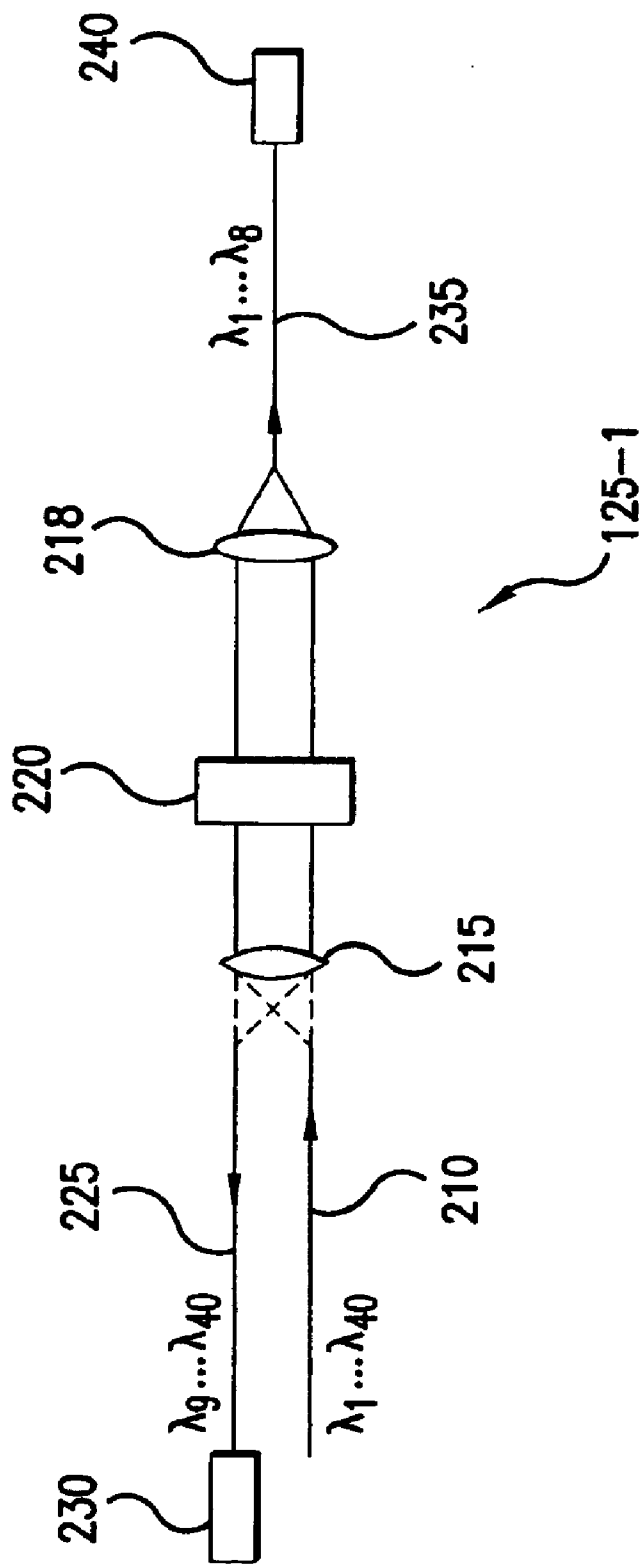

FIG.2

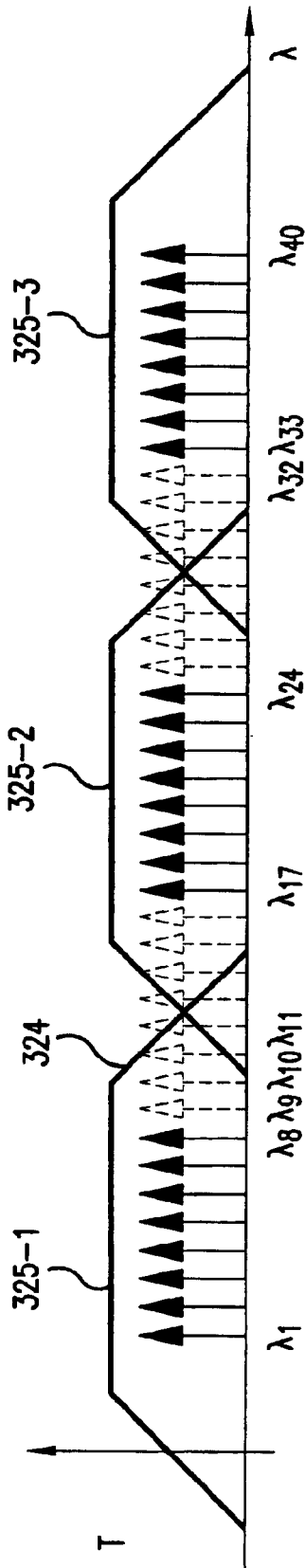

FIG.3

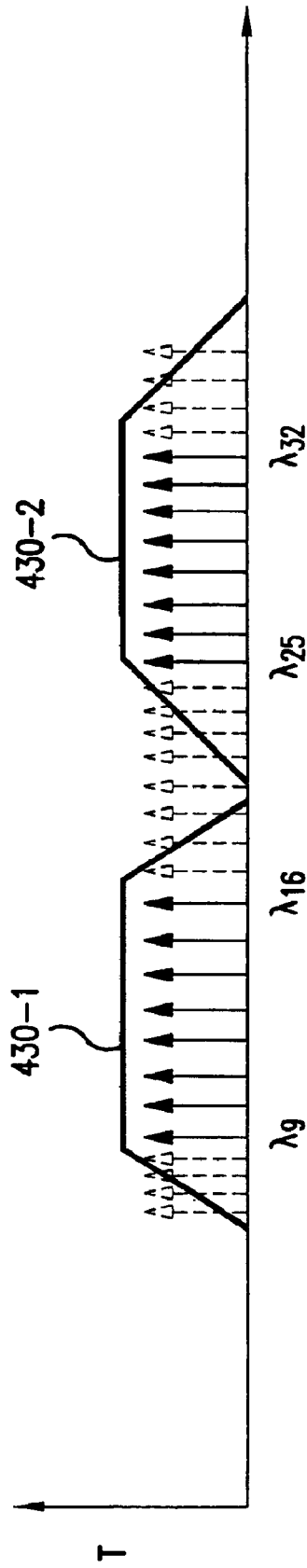

FIG.4

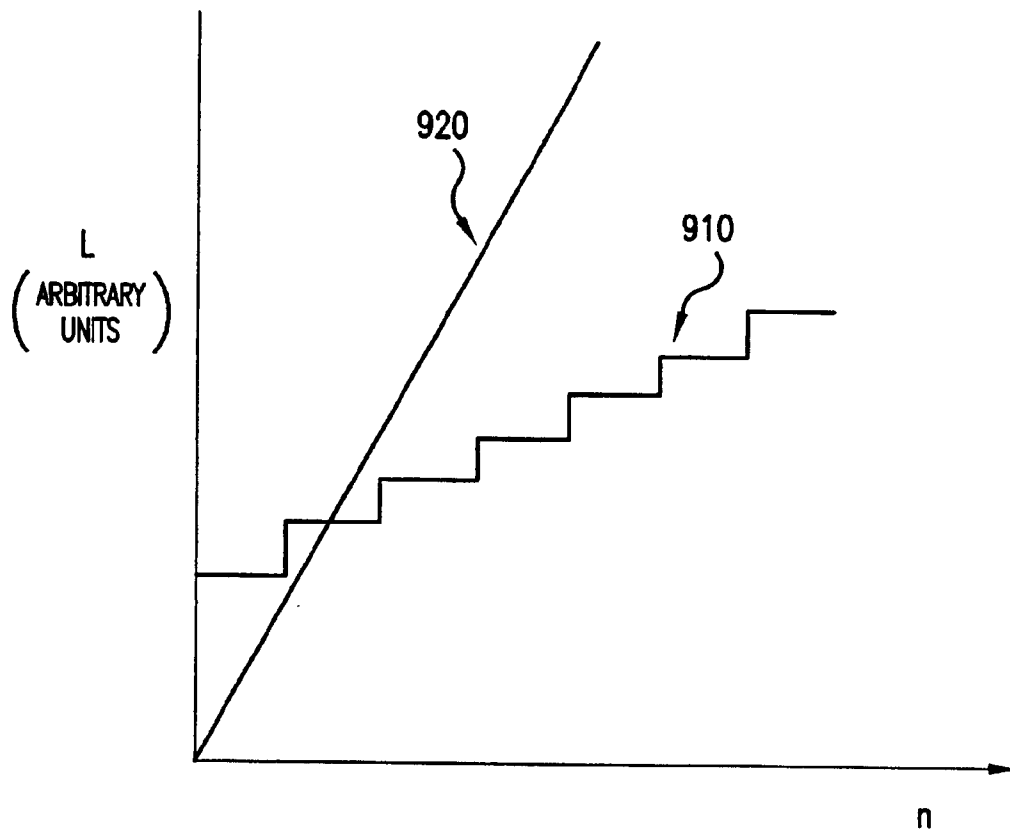

FIG.5

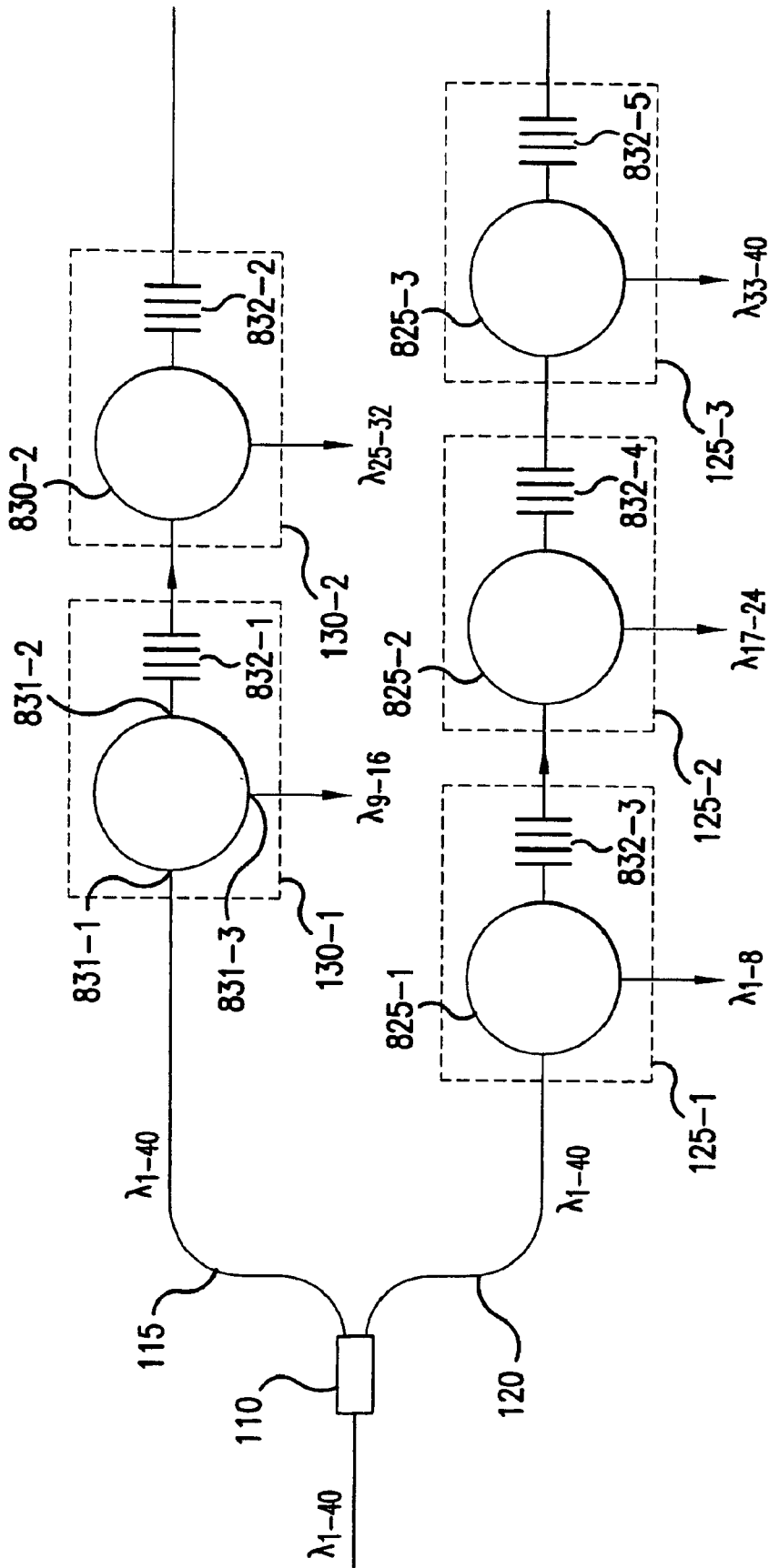

FIG.6

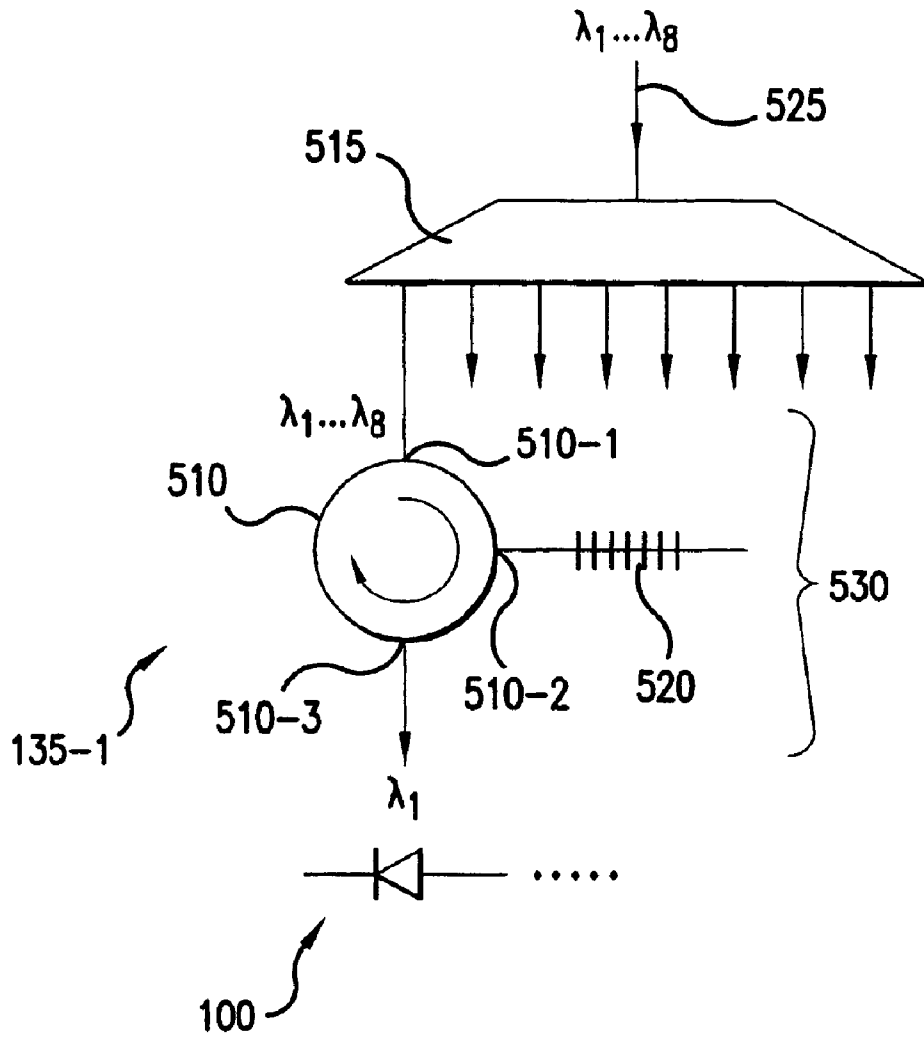

FIG. 7

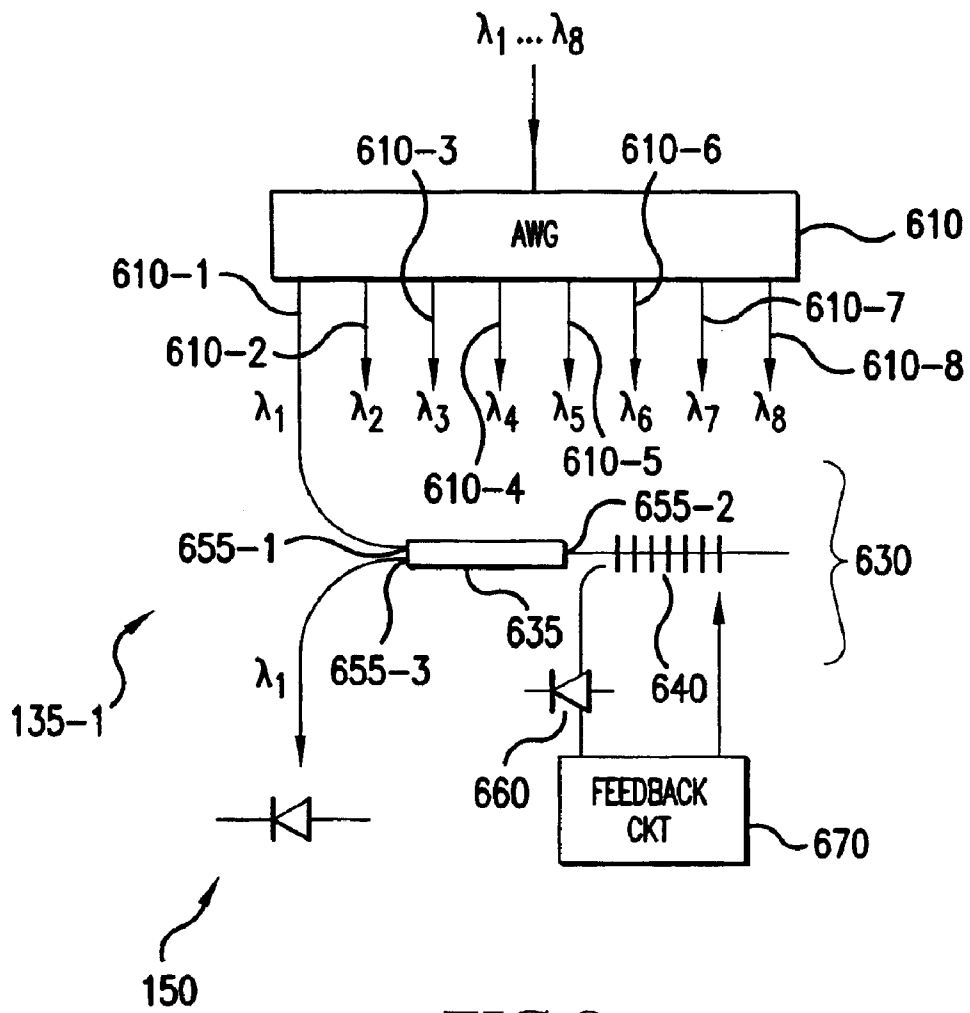

FIG.8

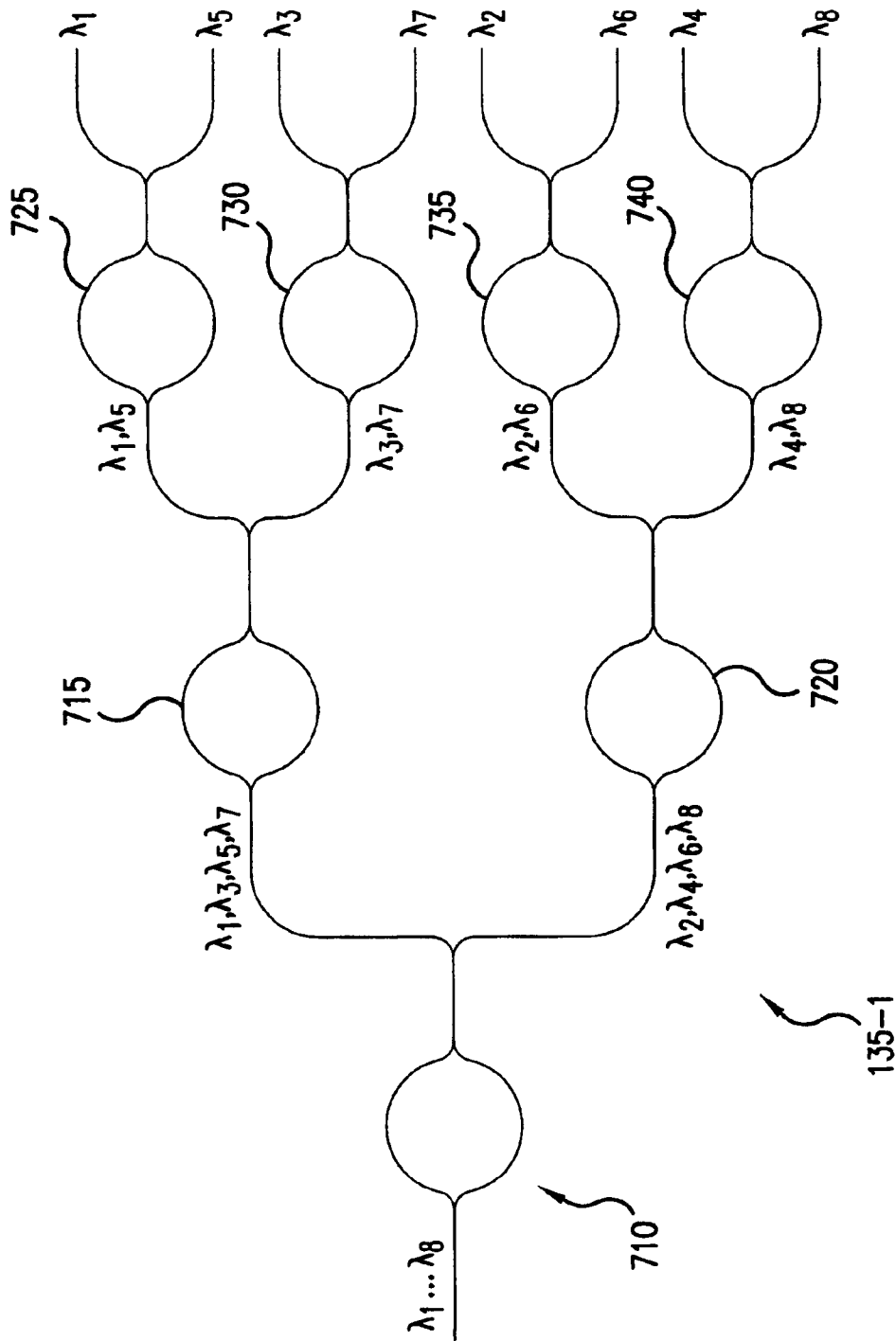

FIG. 9

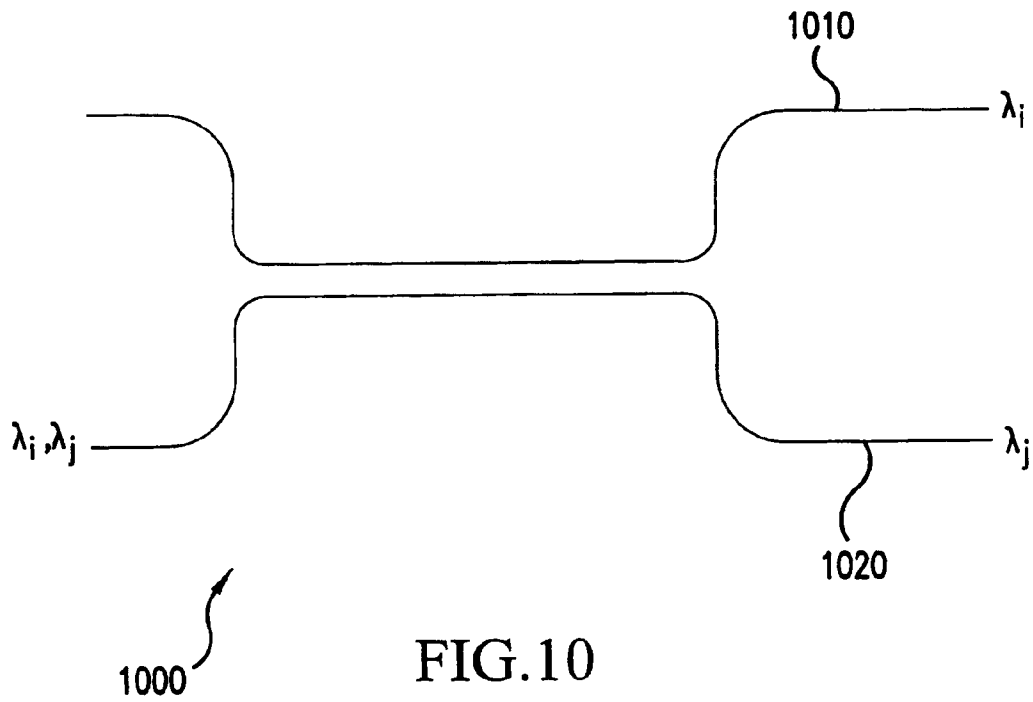

FIG.10

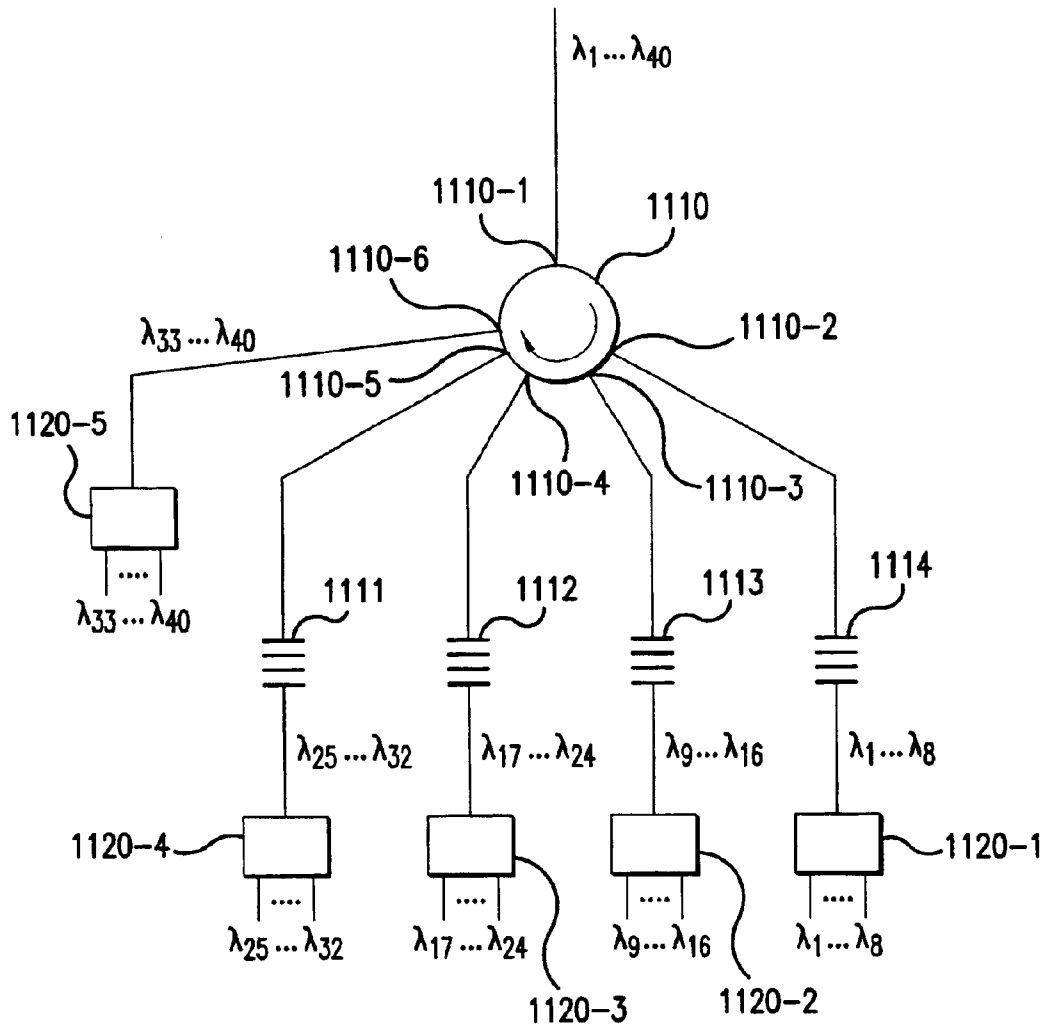

FIG.11

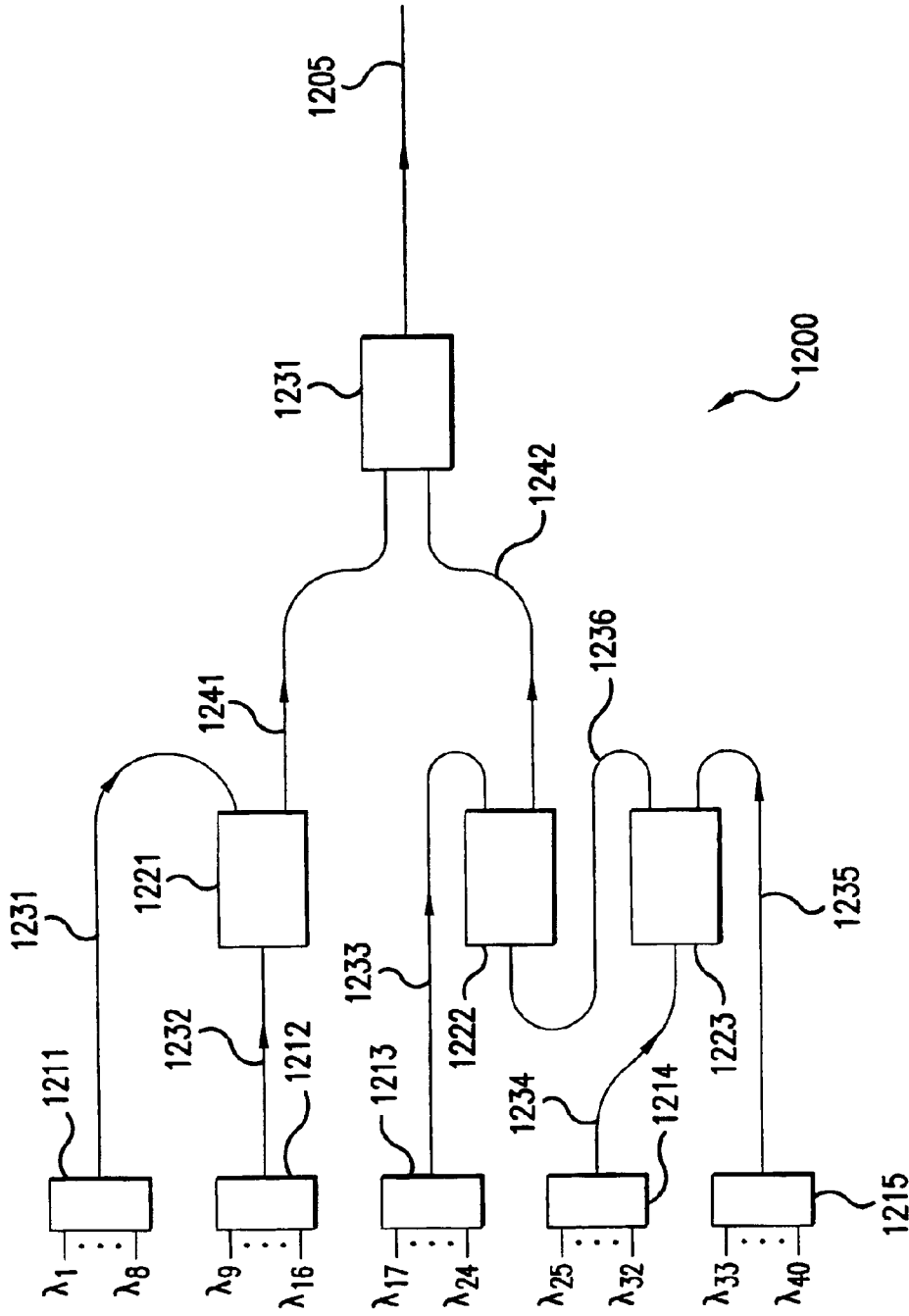

FIG. 12

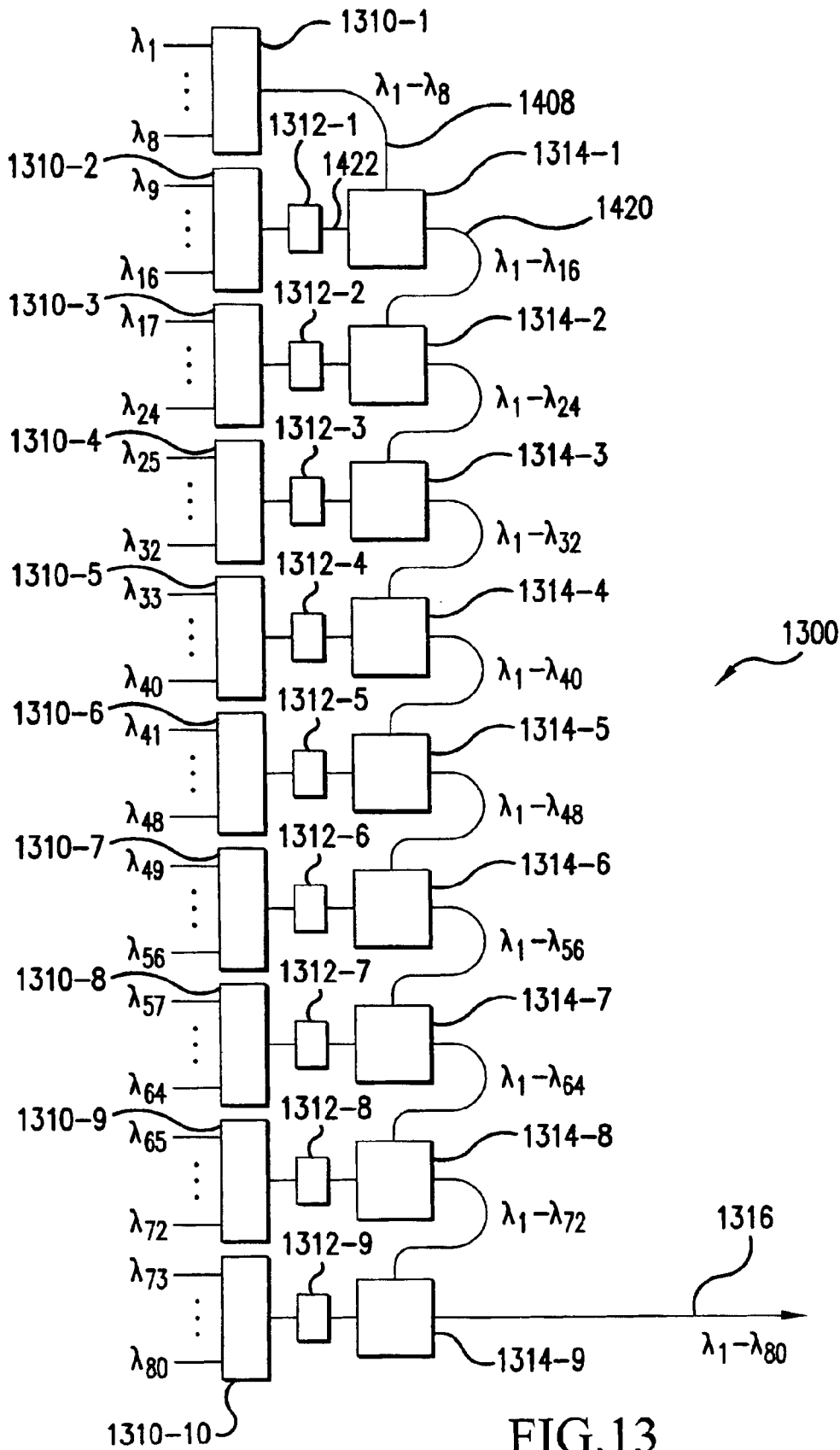

FIG. 13

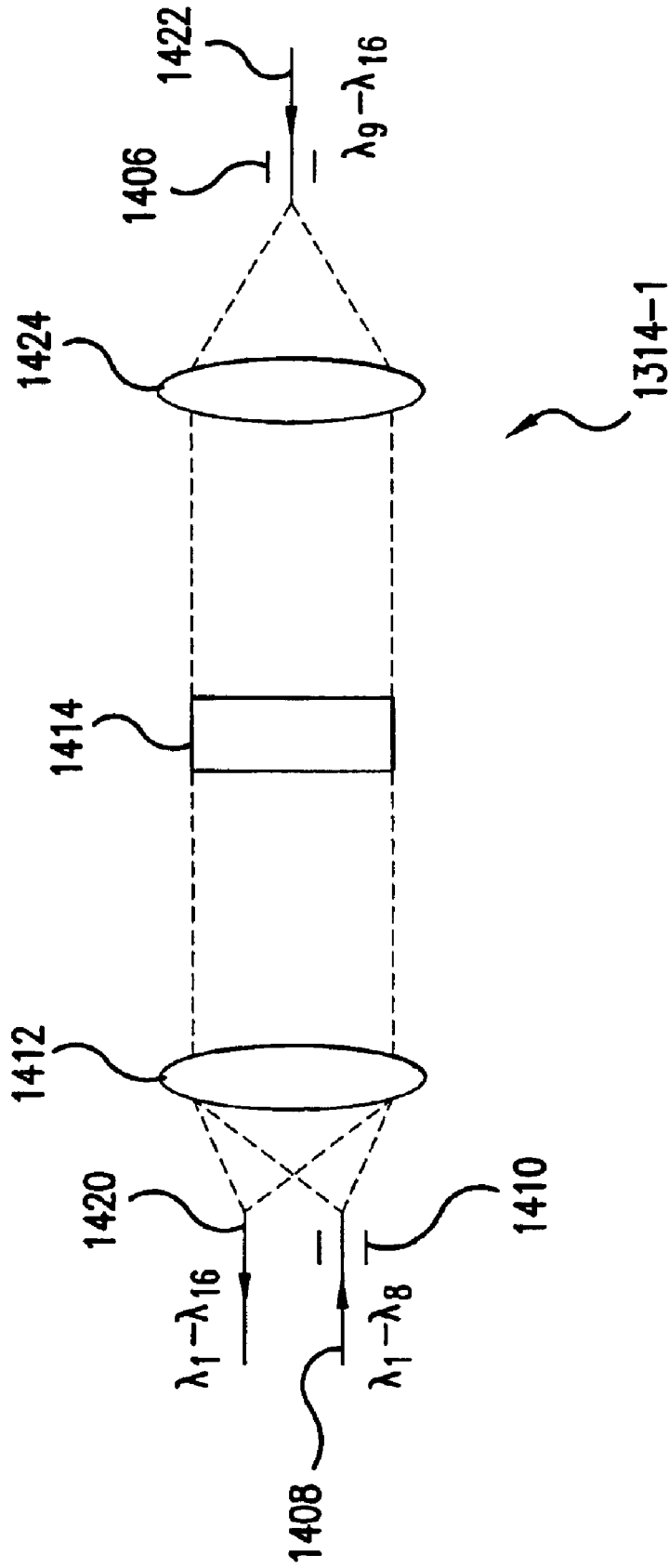

FIG.14

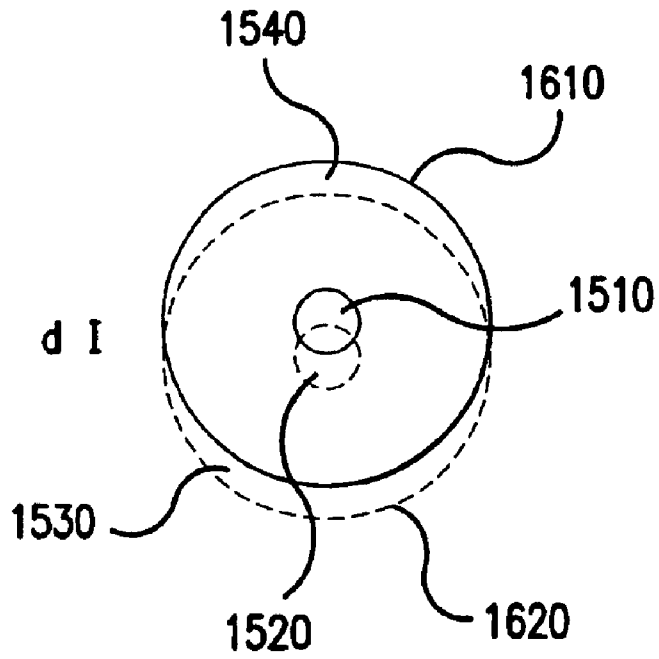

FIG. 15

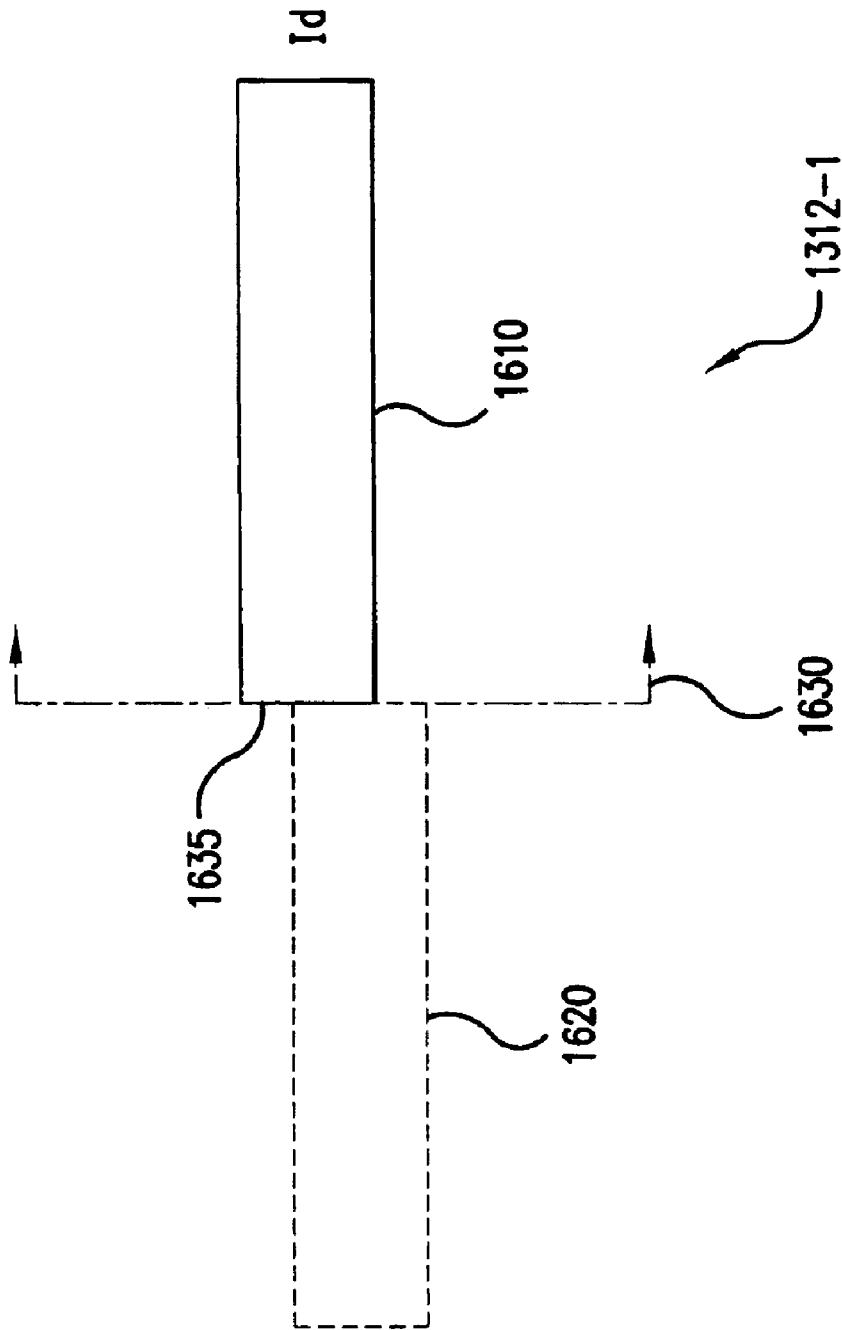

FIG. 16

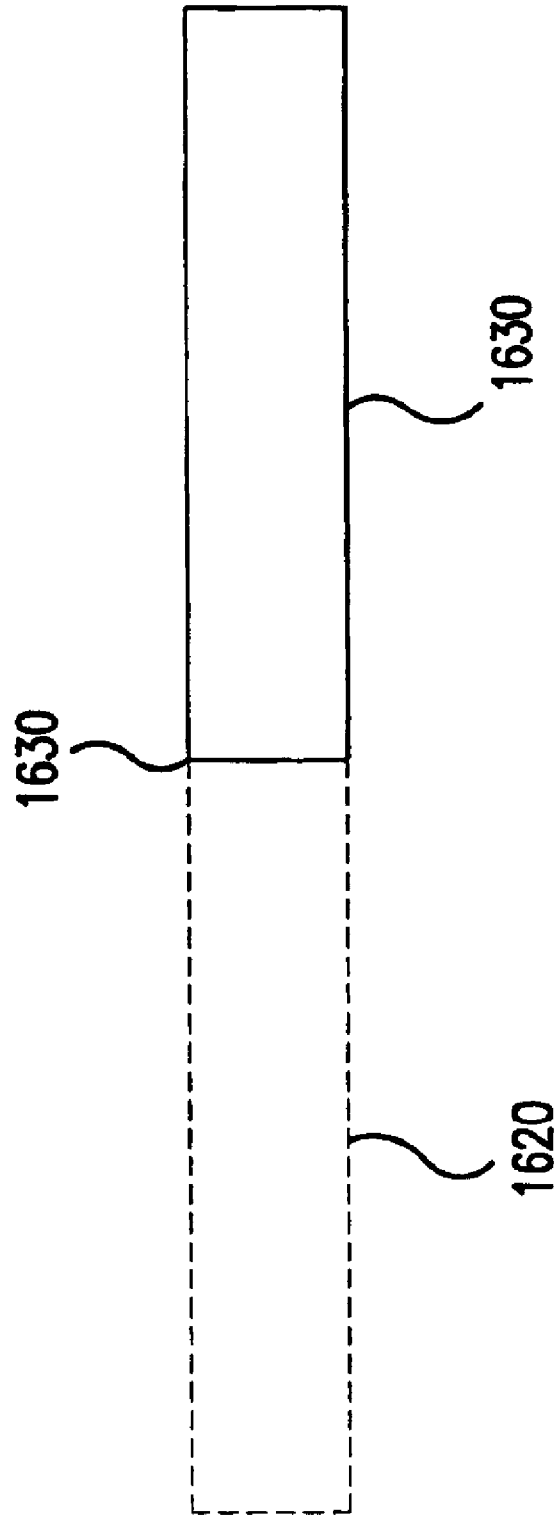

FIG. 17

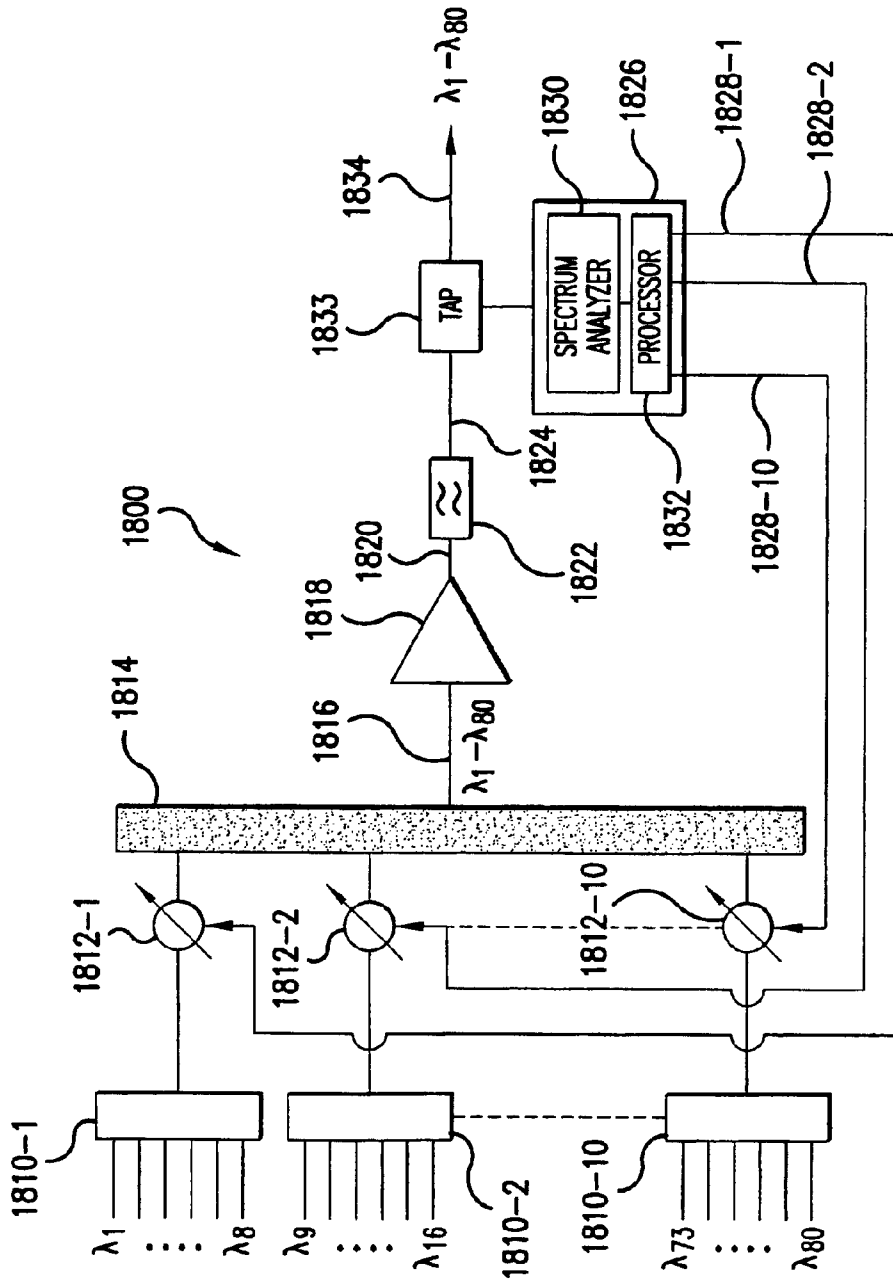

FIG.18

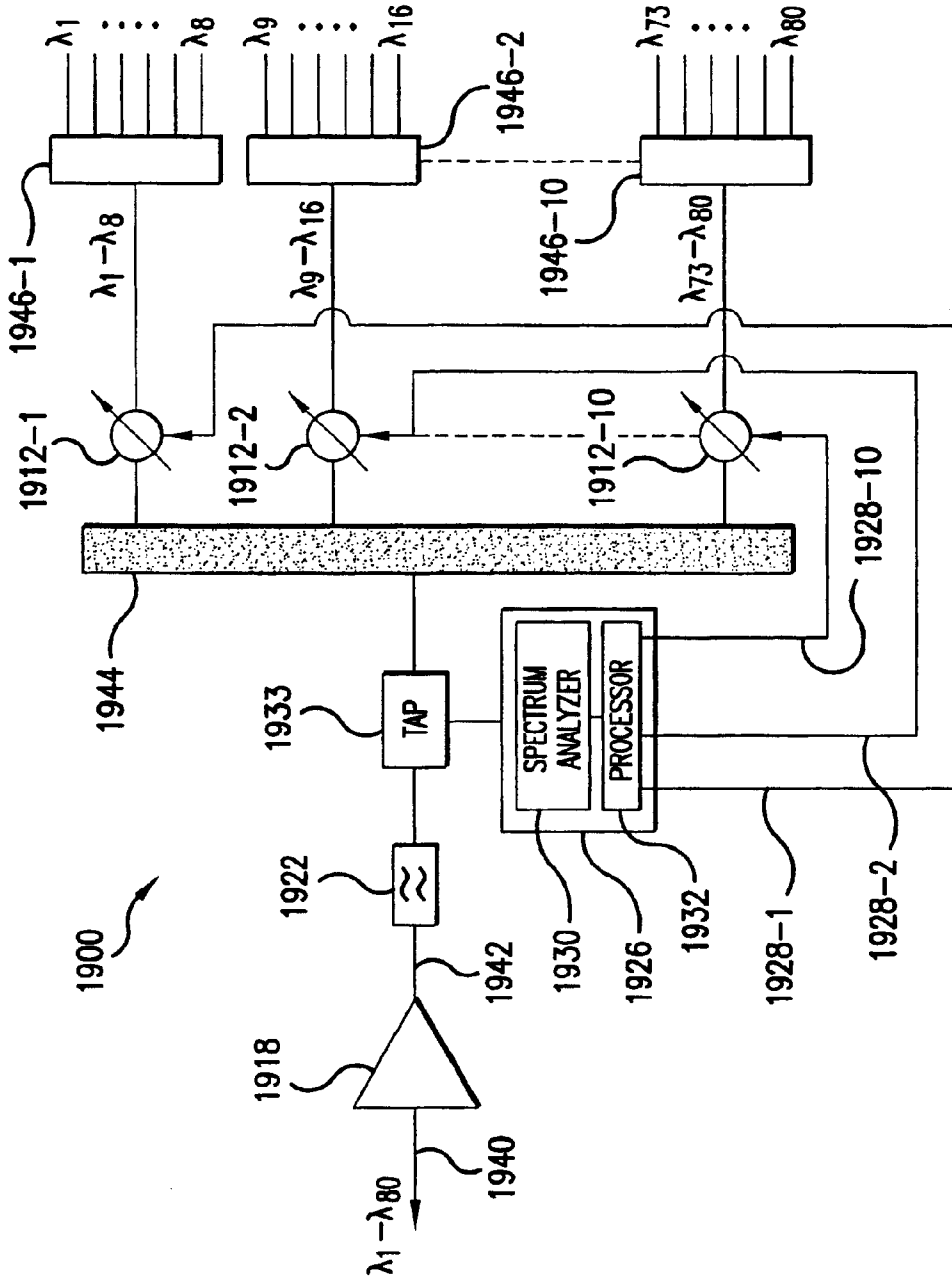

FIG. 19

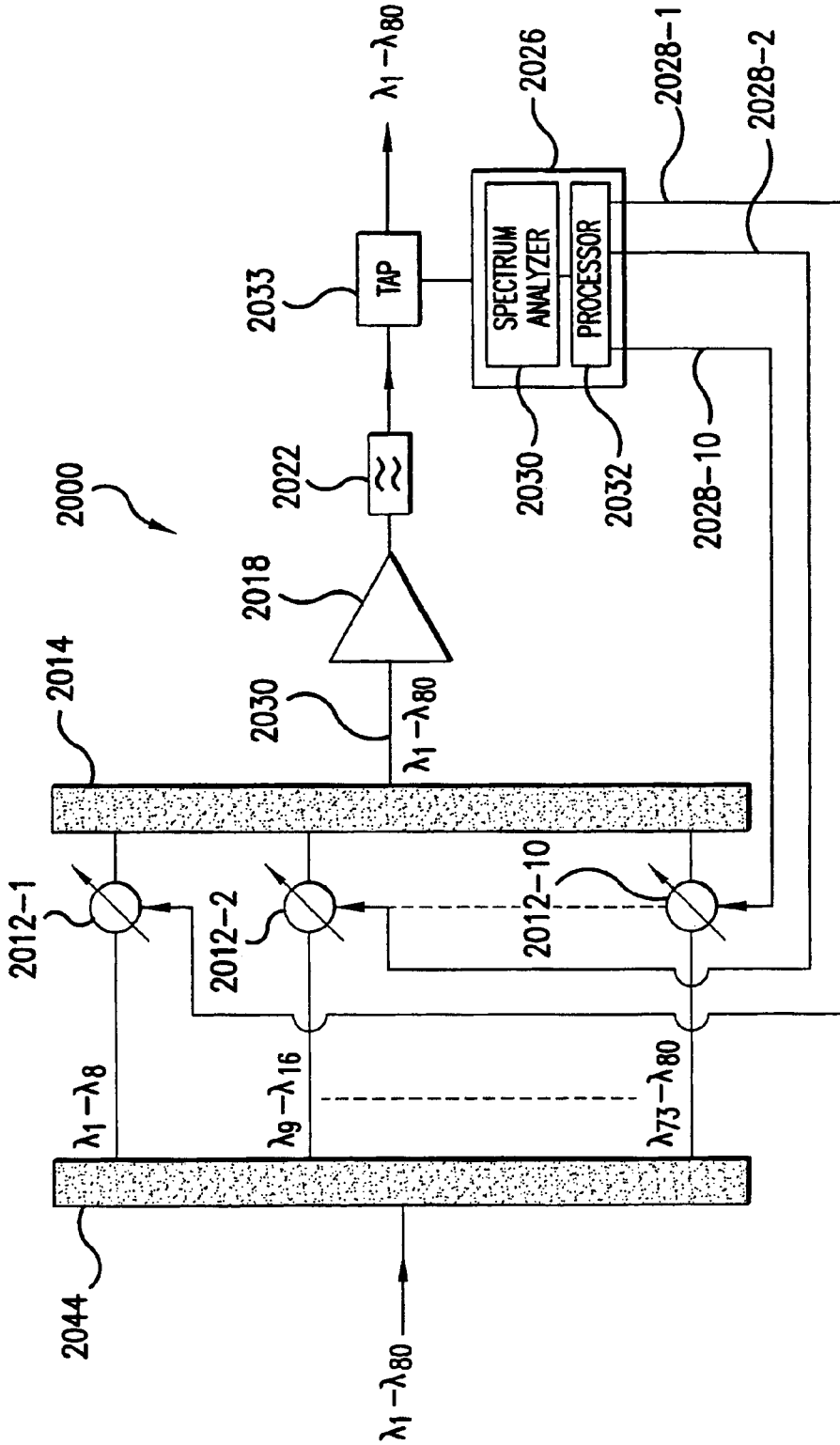

FIG. 20

OPTICAL DEVICE INCLUDING DYNAMIC CHANNEL EQUALIZATION

This application is a Divisional of application Ser. No. 09/493,313, filed on Jan. 28, 2000 now U.S. Pat. No. 6,760,532, and for which priority is claimed under 35 U.S.C. § 120 the entire contents of all are hereby incorporated by reference.

FIELD OF THE INVENTION

The present invention is directed in general to optical devices, and, more particularly, to an optical device including dynamic equalization of optical channel bands for achieving improved performance in a wavelength division multiplexed system.

Optical communication systems are a substantial and fast growing constituent of communication networks. The expression "optical communication system," as used herein, relates to any system that uses optical signals to convey information across an optical waveguiding medium, for example, an optical fiber. Such optical systems include but are not limited to telecommunication systems, cable television systems, and local area networks (LANs). Currently, the many optical communication systems are configured to carry an optical channel of a single wavelength over one or more optical waveguides. To convey information from plural sources, time-division multiplexing is frequently employed (TDM). In time-division multiplexing, a particular time slot is assigned to each signal source, the complete signal being constructed from the portions of the signals collected from each time slot. While this is a useful technique for carrying plural information sources on a single channel, TDM capacity is limited by fiber dispersion and the need to generate high peak power pulses.

While the need for communication services increases, the current capacity of existing waveguiding media is limited. Although capacity may be expanded e.g., by laying more fiber optic cables, the cost of such expansion is prohibitive. Consequently, there exists a need for a cost-effective way to increase the capacity of existing optical waveguides.

Wavelength division multiplexing (WDM) has been explored as an approach for increasing the capacity of existing fiber optic networks. WDM systems typically include a plurality of transmitters, each respectively transmitting signals on a designated one of a plurality of channels or wavelengths. The channels are combined by a multiplexer at one end terminal and transmitted on a single fiber to a demultiplexer at another end terminal where they are separated and supplied to respective receivers.

Recently, dense WDM (DWDM) systems transmitting 8 channels on a single fiber have been proposed. These systems can include a demultiplexer having a 1×8 optical splitter, which receives the 8 channels on an input fiber, and outputs the channels on each of 8 outputs. The power level on each of the outputs, however, is approximately 1/8 the input power level. Optical components are respectively coupled to the outputs of the 1×8 splitter for outputting a corresponding one of the 8 channels, which introduce additional loss.

Although 8 channel WDM systems provide improved capacity, the need for additional capacity has increased with growing Internet traffic and demand for multimedia services. Thus, DWDM systems having higher channel counts are currently being developed. In high channel count systems, however, it is difficult to multiplex and demultiplex a large number of optical channels. For example, in a 40 channel

DWDM system, a 1×40 splitter would be inadequate to demultiplex each of the channels because the power level at each output of such a splitter would be insufficient to maintain an adequate signal to noise ratio. As a result, the transmitted channels cannot be adequately detected. On the other hand, although an optical amplifier could be used to increase the power on the input of the 1×40 splitter, such an amplifier can be difficult to manufacture, and would fail to provide the requisite optical power per channel at higher channel counts. Moreover, if amplifiers were to be provided at each of the outputs of the 1×40 splitter, the cost of the demultiplexer would be excessive.

In addition, signal detection in high channel count, high data rate, and long distance systems can be unreliable as a result of varying signal optical power levels resulting from conventional multiplexing and demultiplexing operations. For example, wavelength dependent variations in the gain or transmission characteristics of network elements can result in significant variations in the optical signal power and signal to noise ratio in the transmitted channels. Attempts have been made to introduce gain-flattening filters at multiplexer/demultiplexer outputs to equalize the channel signal powers, but conventional gain flattening filters also display wavelength-dependent variations in output signal power. Thus the difficulties associated with output signal power variations in the transmitted channels persist.

Thus, there is a need for a multiplexer and demultiplexer suitable for incorporation into a high channel count DWDM system which minimizes power loss and enables adequate detection of the transmitted channels. There is also a need for a scaleable DWDM system, which can readily accommodate additional channels with minimal expense. There is also a need for an optical device for providing channel signal power equalization in wavelength division multiplexed optical communication systems.

SUMMARY OF THE INVENTION

Consistent with the present invention, an optical device is provided comprising a plurality of separate optical paths, each of which receiving a separate group of optical signals. Each group of optical signals is provided to an associated variable optical attenuator. Separate inputs of an optical combiner are each coupled to an output of an associated one of the variable optical attenuators. The optical combiner has an output providing the separate groups of optical signals in an aggregated form on an aggregate optical signal path.

An optical performance monitor is coupled to the aggregate optical signal path, and is configured to detect an optical signal power of each of the separate groups. The monitor is provided in a variety of configurations, and may include, for example, a spectrum analyzer and an appropriately programmed processor circuit. The monitor supplies a feedback signal to corresponding ones of the variable optical attenuators for adjusting a respective attenuation associated with each of the attenuators in dependence of the detected optical signal powers.

The combiner may be provided in a variety of configurations. In one exemplary embodiment, the combiner may include a plurality of cascaded optical filters, each of the optical filters having an input coupled to an output of an associated one of the variable optical attenuators. Also, an amplifier and/or a gain-flattening filter may be coupled to the aggregate optical signal path.

In a multiplexer configuration, the device may further include a plurality of first optical combiners, each of which being coupled to an associated one of the optical paths for

3

supplying a respective one of the separate groups of optical signals. In a line amplifier configuration, the device may further include an optical separator having a plurality of outputs, each of which being coupled to an associated one of the optical paths for supplying a respective one of the separate groups of optical signals.

In a demultiplexer configuration, a device consistent with the invention may include an optical communication path receiving an optical signal including a plurality of separate wavelengths. The optical performance monitor may be coupled to the optical communication path. An optical separator receives an output of the optical performance monitor, and supplies each of the plurality of groups of the separate wavelengths on a separate associated output. Each of a plurality of variable optical attenuators receives a separate one of the separate associated outputs for adjusting an associated attenuation level.

A method for dynamically equalizing power levels associated with groups of optical signals consistent with the invention includes the steps of: providing each of the groups of optical signals on separate optical signal paths; combining each of the groups of optical signals on an aggregate optical signal path; detecting the power level associated with each of the groups of optical signals on the aggregate optical signal path; and attenuating each group of the optical signals on the separate signal paths in dependence of an associated detected power level. In a demultiplexer application, another exemplary method of dynamically equalizing power levels associated with groups of optical signals, includes the steps of: providing the groups of optical signals in an aggregated form on an optical signal path; detecting the power level associated with each of the groups of optical signals on the optical signal path; separating the groups of optical signals onto associated separate optical signal paths; attenuating each group of the optical signals on the associated separate signal paths in dependence of an associated detected power level.

BRIEF DESCRIPTION OF THE DRAWINGS

Advantages of the present invention will be apparent from the following detailed description of the presently preferred embodiments thereof, which description should be considered in conjunction with the accompanying drawings in which:

FIG. 1 illustrates a schematic diagram of an optical demultiplexer in accordance with the present invention;

FIG. 2 illustrates a schematic diagram of an interference filter;

FIG. 3 illustrates transmittance characteristics of filtering elements **125-1**, **125-2** and **125-3** shown in FIG. 1;

FIG. 4 illustrates transmittance characteristics of filtering elements **130-1** and **130-2** shown in FIG. 1;

FIG. 5 illustrates plots of loss vs. channel count for the present invention and a conventional demultiplexer;

FIG. 6 illustrates an additional embodiment of the present invention;

FIG. 7 illustrates an example of a sub-demultiplexer;

FIG. 8 illustrates an additional example of a sub-demultiplexer;

FIG. 9 illustrates a further example of a sub-demultiplexer;

FIG. 10 illustrates a fiber optic coupler demultiplexer for separating two wavelengths;

FIG. 11 illustrates an additional embodiment of the present invention;

4

FIG. 12 illustrates an optical multiplexer in accordance with an aspect of the present invention;

FIG. 13 illustrates an optical multiplexer in accordance with a further aspect of the present invention;

FIG. 14 illustrates a filtering element shown in FIG. 13;

FIG. 15 illustrates a cross-sectional view of an exemplary optical attenuator shown in FIG. 13;

FIG. 16 illustrates a side view of an optical attenuator shown in FIG. 15;

FIG. 17 illustrates a side view of the optical attenuator after fusion splicing.

FIG. 18 illustrates a schematic diagram of an optical multiplexer including a dynamic equalization system consistent with the present invention;

FIG. 19 illustrates a schematic diagram of an optical demultiplexer including a dynamic equalization system consistent with the present invention; and

FIG. 20 illustrates a schematic diagram of an optical amplifier including a dynamic equalization system consistent with the present invention.

DETAILED DESCRIPTION

In accordance with the present invention, optical channels to be demultiplexed are supplied to first and second optical fibers via an optical splitter. Low loss interference filters, for example, coupled to the first and second optical fibers, select respective groups of channels. Each group of channels is next demultiplexed with sub-demultiplexers into individual channels, each of which is then sensed with a corresponding photodetector. Although the optical splitter introduces an optical power loss at the input to the demultiplexer, the interference filters and sub-demultiplexers create little additional loss. As a result, the total power loss associated with the present invention is significantly less than that obtained with a conventional n channel demultiplexer based on a 1×n splitter. Accordingly, large numbers of channels, e.g., in excess of forty can be readily demultiplexed and detected.

Turning to the drawings in which like reference characters indicate the same or similar elements in each of the several views, FIG. 1 illustrates optical demultiplexer **100** consistent with the present invention. As discussed in greater detail below, the exemplary demultiplexer illustrated in FIG. 1 demultiplexes 40 channels. The present invention, however, is not limited to this number of channels. Rather, the present invention is applicable to demultiplexers that can separate any appropriate number of optical channels.

Returning to FIG. 1, optical demultiplexer **100** receives, for example, a plurality of multiplexed optical channels λ_1 - λ_{40} on input optical fiber **105**. The multiplexed channels are emitted by laser transmitters (not shown) coupled to optical fiber **105**. The multiplexed channels are supplied to the input of optical splitter **110**, which supplies channels λ_1 - λ_{40} to first and second output fibers **115** and **120**, respectively. Optionally, optical amplifier **101** may be provided at the input of coupler **110** in order to offset any loss introduced by splitter **110**. Alternatively, the loss imposed by splitter **110** can be compensated by coupling optical amplifiers to output fibers **115** and **120**.

As further shown in FIG. 1, first optical filtering elements **125-1** to **125-3** are coupled to first output fiber **120**, and second filtering elements **130-1** and **130-2** are coupled to second output fiber **115**. Each of these filtering elements typically includes an interference filter commercially available from JDS Fitel or DiCon, for example.

A simplified diagram of filtering element **125-1** incorporating an interference filter, for example, is illustrated in

FIG. 2. Filtering element **125-1** receives channels λ_1 - λ_{40} on input fiber **210** having an end portion spaced from graded refractive index (GRIN) lens **215**. As a result, light emitted from the end portion diverges prior to impinging on lens **215**. Channels λ_1 - λ_{40} are collimated by lens **215** and directed toward dielectric thin film filter **220**. Thin film filter **220** includes a substrate coated with a plurality of thin dielectric films of appropriate thickness and number to pass, in this case, channels λ_1 - λ_8 , and reflect channels λ_{17} - λ_{40} . Channels λ_1 - λ_8 are thus transmitted to GRIN lens **218** where they are focused onto an end portion of output fiber **235** and transmitted to a corresponding sub-demultiplexer via output port **240** of filtering element **125-1**. Channels λ_9 - λ_{40} , however, are reflected back to GRIN lens **215**, focused onto fiber **225** and output through port **230** to filtering element **125-2**, which along with filtering element **125-3**, typically has a similar constriction as filtering element **125-1**.

The transmittance vs. wavelength characteristics of filtering elements **125-1** to **125-3** are shown in FIG. 3. Transmittance band **325-1** of filtering element **125-1** has a relatively high transmittance over a range of wavelengths including the first eight channels, λ_1 - λ_8 . As noted above, therefore, these channels are transmitted toward an output port of filtering element **125-1**. It should be noted, however, that channels λ_9 - λ_{11} , for example, are also transmitted, but only partially, since they lie in the roll-off region **324** of transmittance band **325-1**. Remaining channels λ_{12} - λ_{40} , as well as channels λ_9 - λ_{11} at a substantially reduced power level, are reflected to filtering element **125-2** having high transmittance band **325-2**. As a result, channels λ_{17} - λ_{24} are transmitted toward the output port of filtering element **125-2**. As further shown in FIG. 3, however, channels λ_{25} - λ_{27} , for example, adjacent λ_{17} - λ_{24} are also transmitted, but to a lesser extent. Remaining channels λ_{28} - λ_{40} are reflected and output to filtering element **125-3** of which channels λ_{33} - λ_{40} fall within high transmittance band **325-3** and are thus passed to an output port of filtering element **125-3**. Channels λ_{28} - λ_{31} , however, are partially transmitted.

As further shown in FIG. 1, channel groups λ_1 - λ_8 , λ_{17} - λ_{24} , and λ_{33} - λ_{40} are respectively directed to sub-demultiplexers **135-1**, **135-2** and **135-3** where further demultiplexing is performed to output individual channels on corresponding output ports. These output ports, in turn, are coupled to respective ones of photodiodes **150** where the channels are converted into electrical signals for processing by appropriate circuitry (not shown). The term sub-demultiplexer is used herein to describe an optical apparatus that demultiplexes the groups of channels respectively output from the filtering elements. Sub-demultiplexers **135-1**, **135-2** and **135-3** are discussed in greater detail below.

As noted above, channels lying outside the high transmittance bands of filtering elements **125-1**, **125-2** and **125-3** are only partially reflected due to the relatively broad roll-off regions of the transmittance characteristics of interference filters, for example. Accordingly, channels adjacent the intended channel sub-groups incur a significant amount of power loss and cannot be effectively demultiplexed. These channels are therefore supplied by filtering elements **130-1** and **130-2** coupled to second output fiber **115**, as discussed in greater detail below with reference to FIG. 4.

As shown in FIG. 4, filtering element **130-1** has high transmittance band **430-1** extending over wavelengths λ_9 - λ_{16} . Filtering element **130-1** typically has a similar construction to filtering element **125-1**, and therefore transmits channels λ_9 - λ_{16} for output to corresponding sub-demultiplexer **140-1** and further demultiplexing. Remaining

channels λ_1 - λ_8 and λ_{17} - λ_{40} are reflected to filtering element **130-2** having high transmittance band **430-2** encompassing channels λ_{25} - λ_{32} . Accordingly, channels λ_{25} - λ_{32} are transmitted through filtering element **130-2** and directed toward sub-demultiplexer **140-2** for further demultiplexing into individual channels.

Channels lying adjacent the high transmittance bands **430-1** and **430-2**, like those channels discussed previously adjacent high reflectance bands **325-1** to **325-3**, are partially transmitted by filtering elements **130-1** and **130-2** and are thus difficult to detect after further demultiplexing. These channels, however, lie within the high transmittance bands of filtering elements **125-1** to **125-3** and are thus demultiplexed through sub-demultiplexers **135-1** to **135-3**, respectively, as noted above. Therefore, in the presently described example of the present invention, first output fiber **120**, filtering elements **125-1** to **125-3** and corresponding sub-demultiplexers **135-1** to **135-3**, serve to demultiplex channels λ_1 - λ_8 , λ_{17} - λ_{24} and λ_{33} - λ_{40} , respectively. Additionally, second output fiber **120**, filtering elements **130-1** and **130-2** and corresponding sub-demultiplexers **140-1** and **140-2** serve to demultiplex channels λ_9 - λ_{16} and λ_{25} - λ_{32} , respectively. Accordingly, alternating groups of channels are respectively selected by filtering elements **125-1** to **125-3** and **135-1** to **135-3**.

Alternatively, if only 40 channels are to be separated by the demultiplexer in accordance with the present invention, filtering elements **130-2** and **125-3** can be omitted and sub-demultiplexers **140-2** and **135-3** can be coupled directly to the outputs of filtering elements **130-1** and **125-2**, respectively.

Filtering elements **125-1** to **125-3**, **130-1** and **130-2** introduce little power loss to the selected sub-groups of channels. For example, the power loss associated with the channels reflected by the filtering elements is typically about 0.5 dB, and the loss associated with the channels transmitted through the filtering elements is about 0.7 dB. Thus, the overall loss of the demultiplexer in accordance with the present invention is significantly reduced.

It is noted that as the channels propagate down one of output fibers **115** or **120** in FIG. 1, the transmission loss through each filtering element can accumulate. However, since the loss associated with each filtering element is so low, channels can pass through four filtering elements along one of output fibers **115** and **120**, and incur less than 3 dB of loss. Accordingly, additional channels can be demultiplexed with little additional loss simply by concatenating additional filtering elements with fiber patch cord, for example, between adjacent couplers. Alternatively, filtering elements can be easily added by coupling the output of one filtering element to one end of an optical fiber via a first fiber optic coupler and coupling the other end of the optical fiber to another filtering element via a second fiber optic coupler. Thus, the demultiplexer in accordance with the present invention is readily expandable and upgradeable to accommodate more channels with minimal expense and relatively little loss.

FIG. 5 illustrates loss L as a function of channel count n in accordance with the present invention (curve **910**) and a conventional 1×n splitter based demultiplexer (curve **920**). As seen in FIG. 5, at low channel counts, the loss associated with the present invention is higher than the conventional demultiplexer. This is due to the loss introduced by the 1×2 splitter **110**, which imposes a minimum loss in the demultiplexer. At higher channel counts, however, the loss associated with the conventional demultiplexer increases lin-

early with n (curve **920**). On the other hand, the loss associated with the present invention (curve **910**) is stepped and increases at a much more gradual rate due, at least in part, to the low loss of the filtering elements. Therefore, at higher channel counts, channels demultiplexed in accordance with the present invention experience less loss than those demultiplexed with a conventional $1 \times n$ splitter.

FIG. 6 illustrates an alternative embodiment in which each filtering element constitutes a combination of a circulator and grating. In particular, filtering element **130-1** includes a circulator **830-1** receiving channels λ_{1-40} at a first circulator port **831-1** coupled to output fiber **115**. These channels are circulated to port **831-2** and output to in-fiber Bragg grating **832-1**, which is configured to have a high reflectivity band that coincides with the band of channels λ_{9-16} . Accordingly, channels λ_{9-16} are reflected back to port **831-2** while the remaining channels are transmitted to circulator **830-2**. Channels λ_{9-16} are then circulated to output port **831-3** and supplied to a corresponding sub-demultiplexer. In a similar fashion circulators **830-2**, **825-1**, **825-2** and **825-3** output channel groups λ_{25-32} , λ_{1-8} , λ_{17-24} and λ_{33-40} in conjunction with in-fiber Bragg gratings **832-2**, **832-3**, **832-4**, and **832-5**, respectively.

Typically, in-fiber Bragg gratings **832-3**, **832-4** and **832-5** reflect successively lower bands or wavelengths, such that the wavelengths in channel group λ_{1-8} are greater than the wavelengths in channel group λ_{17-24} , and the wavelengths in channel group λ_{17-24} are greater than the wavelengths in channel group λ_{33-40} . Further, in-fiber Bragg gratings **831-1** and **832-2** reflect successively lower bands of wavelengths. As a result, the demultiplexer shown in FIG. 6 avoids cladding or radiation mode loss.

Examples of sub-demultiplexers will next be described with reference to FIGS. 7-10. Although exemplary configurations are discussed in detail with respect to sub-demultiplexer **133-1**, it is understood that the remaining sub-demultiplexers described above can have a similar structure. Moreover, the present invention is not limited to these specific sub-demultiplexer configurations nor the specific number of inputs and outputs disclosed. Rather, it is understood that any optically demultiplexing component capable of demultiplexing a group of channels can be used.

FIG. 7 illustrates a first exemplary construction of sub-demultiplexer **133-1**. As shown in FIG. 7, sub-demultiplexer **133-1** receives channels λ_{1-8} at an input **525** of a 1×8 splitter **515**, commercially available from IOT, for example. Splitter **515** has eight outputs, each of which supplying channels λ_{1-8} to a corresponding one of eight optical selectors **530**. Splitter **515**, as well as splitter **110**, may include a waveguide doped with an optically active material, such as erbium. Such a waveguide may further be optically pumped so that splitter **515** has reduced loss or provides optical gain.

In FIG. 7, only one of the selectors is shown including a three port circulator **510** having a first port **510-1** for receiving channels λ_{1-8} from one of the outputs of splitter **515**. These channels are transmitted to in-fiber Bragg grating **520** via second port **510-2** of circulator **510**. Typically, in-fiber Bragg grating **520** has a reflectance characteristic as a function of wavelength such that a reflectivity maximum is obtained at a desired channel or wavelength, e.g., λ_1 . Thus, only channel λ_1 is reflected back to second port **510-2** and circulated to third circulator port **510-3**, which outputs channel λ_1 to one of photodiodes **150** for subsequent detection and further processing. Likewise, the in-fiber Bragg gratings in the remaining selectors have reflectivity maxima

that respectively reflect a corresponding one of each of remaining wavelengths $\lambda_2-\lambda_8$ for output to one of photodiodes **150**.

FIG. 8 illustrates an alternative construction for sub-demultiplexer **133-1**. Here, the channel group λ_{1-8} is supplied to a planar arrayed waveguide grating (AWG) **610** or dielectric thin film demultiplexer, which supplies a respective channel on each of outputs **610-1** to **610-8**. If the spacing between adjacent ones of channels λ_{1-8} is relatively narrow, AWG **610** can introduce an unacceptably high level of undesired cross-talk. Accordingly, additional filtering may be required. Thus, a selector **630** is further illustrated in FIG. 8 to isolate a single channel, e.g., λ_1 , and remove any cross-talk. In this case, selector **630** includes a coupler **655** receiving substantially channel λ_1 at a first port **655-1**. The input light is next supplied to in-fiber Bragg grating **640** through second port **655-2**. In-fiber Bragg grating **640** substantially reflects only channel λ_1 , while passing other wavelengths. Thus, channel λ_1 is reflected back to second port **655-2** and output to one of photodiodes **150** via third output port **655-3** of coupler **655**.

As further shown in FIG. 8, feedback circuit **670** is optionally provided to insure that grating **640** reflects at the intended wavelengths. As is generally understood, an in-fiber Bragg grating typically includes a periodic variation of index of refraction, with the spacing between refractive index peaks defining, in part, the wavelength to be reflected by the grating. Variations in the wavelength of light reflected by grating **640** can be sensed with photodiode **660**, which supplies an electrical signal to a feedback circuit **670**. Feedback circuit **670**, in turn, generates an appropriate voltage signal to adjust a temperature regulator coupled to grating **640**. Since the grating refractive index spacing changes with temperature, the temperature of the grating is set by feedback circuit **670** to alter the grating spacing so that grating **640** reflects a desired wavelength.

FIG. 9 illustrates a further exemplary construction of sub-demultiplexer **133-1**. In this instance, sub-demultiplexer **133-1** comprises a plurality of Mach-Zehnder interferometers. It is known that Mach-Zehnder interferometers, which include optical waveguides of varying lengths, can be used to separate wavelengths (see for example, published European Patent Application EP0482461). Accordingly, as shown in FIG. 9, Mach-Zehnder interferometers can be cascaded to separate a group of wavelengths. For example, Mach-Zehnder interferometer **710** separates input channels λ_{1-8} into sub-groups of channels $\lambda_{1,3,5,7}$ and $\lambda_{2,4,6,8}$, respectively. Channel sub-group $\lambda_{1,3,5,7}$ is supplied to Mach-Zehnder interferometer **715** and channel sub-group $\lambda_{2,4,6,8}$ is supplied to Mach-Zehnder interferometer **720**. As further shown in FIG. 9, Mach-Zehnder interferometers **715** and **720** further break down these channel sub-groups to channel pairs $\lambda_{1,5}$, $\lambda_{3,7}$, $\lambda_{2,6}$, and $\lambda_{4,8}$ which are further demultiplexed into individual channels by Mach-Zehnder interferometers **725**, **730**, **735** and **740**, respectively.

Fiber optical couplers, commercially available from Applied Fiber Optics, Inc. and Gould, for example, can also be used to demultiplex the groups of channels supplied by the filtering elements. Fiber optic coupler **1000** is illustrated in FIG. 10 in which two wavelengths λ_i and λ_j are separated and supplied on respective outputs **1010** and **1020**. A plurality of such fiber optic couplers can be cascaded in a manner similar to that shown in FIG. 9 to thereby demultiplex a plurality of wavelengths within a given group of channels. If necessary, selectors **530** or **630** may be provided at the outputs of Mach-Zehnder interferometers **725**, **730**, **735** and **740** of FIG. 7, or at the outputs of the cascaded fiber

optic couplers **1000**, in order to reject any extraneous wavelengths, e.g., cross-talk.

FIG. **11** shows an alternative embodiment of the present invention, whereby splitter **110** and filtering elements **125-1** to **125-3**, **135-1** and **135-2** are replaced by five port circulator **1110** and in-fiber Bragg gratings **1111** to **1114**. Channels λ_{1-40} are supplied to a first port **1110-1** of circulator **1110** and are output through port **1110-2**. In-fiber Bragg grating **1114** is configured to transmit channels λ_{1-8} and reflect channels λ_{9-40} . Accordingly, channels λ_{1-8} are supplied to sub-demultiplexer **1120-1** for further demultiplexing while channels λ_{9-40} are reflected back to second port **1110-2** and output to port **1110-3**. In-fiber Bragg grating **1113**, which is coupled to second port **1110-3**, is configured to reflect channels λ_{17-40} and transmit channels λ_{9-16} . As a result, channels λ_{9-16} are passed to sub-demultiplexer **1120-2** for further demultiplexing and channels λ_{17-40} are reflected back to port **1110-3** and output through port **1110-4**.

In-fiber Bragg gratings **1112** and **1111**, coupled to corresponding ports **1110-4** and **1110-5**, are configured to transmit channel groups λ_{17-24} and λ_{25-32} , respectively, and reflect the remaining channels. Thus, channel groups λ_{17-24} and λ_{25-32} are selected in a manner similar to that described above, and supplied to corresponding sub-demultiplexers **1120-3** and **1120-4** for further demultiplexing. In addition, channels λ_{33-40} are output through port **1110-6** and supplied to sub-demultiplexer **1120-5** for further demultiplexing. Typically, sub-demultiplexers **1120-1** to **1120-5** have a structure similar to that shown in FIG. **7**.

FIG. **12** illustrates optical multiplexer **1200** in accordance with the present invention for multiplexing forty channels onto a single fiber **1205**. As seen in FIG. **12**, each channel input to multiplexer **1200** is supplied on a respective input optical communication path or line to one of optical combiners **1211** to **1215**. Optical combiners **1211** to **1215** can be similar to optical splitter **515**, but with the inputs and outputs reversed. As further shown in FIG. **12**, combiner **1211** receives channels λ_1 - λ_8 on respective input lines and combines these channels as a channel group onto a single output line **1231**. Likewise, channel groups λ_9 - λ_{16} , λ_{17} - λ_{24} , λ_{25} - λ_{32} , and λ_{33} - λ_{40} are output from combiners **1212**, **1213**, **1214** and **1215** on lines **1232**, **1233**, **1234** and **1235**, respectively. Lines **1231** and **1232** are fed to an additional combiner such as a filtering element **1221**, commercially available from JDS Fitel or E-Tek, for example, for combining channel groups λ_1 - λ_8 and λ_9 - λ_{16} onto line **1241**. Lines **1234** and **1235** are coupled to filtering element **1223**, which combines λ_{25} - λ_{32} and λ_{33} - λ_{40} onto a single line **1236**, and lines **1233** and **1236** are fed to filtering element **1222**, which combines channel groups λ_{17} - λ_{24} , λ_{25} - λ_{32} , λ_{33} - λ_{40} onto a single line **1242**. Lines **1241** and **1242** are connected to coupler **1231**, similar in construction to splitter **110** but having the inputs and outputs reversed, for combining channel groups λ_1 - λ_8 , λ_9 - λ_{16} , λ_{17} - λ_{24} , λ_{25} - λ_{32} , and λ_{33} - λ_{40} onto line **1205**.

Optical multiplexer **1200** is readily expandable by adding additional combiners and filtering elements.

FIG. **13** illustrates an alternative optical multiplexer **1300**, in accordance with a further aspect of the present invention, which can also multiplex a relatively large number of channels. Optical multiplexer **1300** is shown multiplexing 80 channels, but any appropriate number of channels can be suitably multiplexed with the multiplexer in accordance with the present invention.

Multiplexer **1300** includes a plurality of conventional 1×8 combiners **1310-1** to **1310-10**, for example, each having

eight inputs receiving a respective one of eight channels. Combiners **1310-1** to **1310-10** can include one or more of the following: dielectric filters, fiber couplers, planar waveguides, arrayed waveguide routers, and appropriate combinations of fiber Bragg gratings and circulators. Combiners **1310-1** to **1310-10** combine the received channels onto corresponding outputs, which are coupled to respective optical attenuators **1312-1** to **1312-9**. A series of cascaded combiners, including for example optical filter elements **1314-1** to **1314-9**, generally receive optical signal inputs from corresponding optical attenuators **1312-1** to **1314-9**, and add these signals to signals input from a preceding optical filter element. In particular, filter element **1314-1** adds channels λ_1 to λ_8 received from combiner **1310-1** and channels λ_9 to λ_{16} output from combiner **1310-2** via attenuator **1312-1**. The aggregated channels, channels λ_1 to λ_{16} , are passed to filtering element **1314-2**, which adds channels λ_{17} to λ_{24} output from attenuator **1312-2** thereto. In a similar fashion channel groups λ_{25} to λ_{32} , λ_{33} to λ_{40} , λ_{41} to λ_{48} , λ_{56} to λ_{64} , and λ_{72} to λ_{80} are successively added by filters **1314-3** to **1314-9**. The final filtering element stage **1314-9** outputs the entire aggregation of channels, λ_1 to λ_{80} onto a single output fiber **1316**.

An exemplary filtering element **1314-1** is illustrated in greater detail in FIG. **14**. Filtering element **1314-1** has a similar construction as that shown in FIG. **2**. For example, channels λ_9 to λ_{16} are added to channels λ_1 to λ_8 by supplying channels λ_9 to λ_{16} through port **1406** and channels λ_1 to λ_8 through port **1410**. Channels λ_9 to λ_{16} are emitted from an end of fiber **1422**, collimated by lens **1424** and transmitted through dielectric filter **1414**. Dielectric filter **1414** typically includes a transparent substrate coated with a plurality of dielectric layers configured to transmit, in this case, a band of wavelengths including channels λ_9 to λ_{16} to lens **1412**. Channels λ_9 to λ_{16} are then focused onto an end of output fiber **1420**. Channels λ_1 to λ_8 , however, are emitted from an end of fiber **1408**, collimated by lens **1412**, and reflected dielectric filter **1414**, which reflects wavelengths outside the λ_9 to λ_{16} band. Channels λ_1 to λ_8 are next focused onto the end of output fiber **1420**, and are thus added with channels λ_9 to λ_{16} .

Channels λ_1 to λ_8 , however, incur a loss when combined with channels λ_9 to λ_{16} in filtering element **1314-1**, and experience further loss when combined with remaining channels λ_{17} to λ_{72} in filtering elements **1314-2** to **1314-9**. Likewise, channels λ_9 to λ_{72} accumulate varying degrees of loss when output from combining filters **1314-2** to **1314-9**. Thus, in the absence of attenuators **1312-1** to **1312-9**, channels output from multiplexer **1300** have unequal optical power. In WDM systems, however, substantially uniform channel power is desirable, because optical amplifiers downstream from the multiplexer may otherwise substantially degrade the optical signal-to-noise ratio of the low power channels. In addition, noise in a receiver can adversely affect detection of low power signals.

In order to insure, therefore, that each channel output from multiplexer **1300** has substantially the same optical power, attenuators **1312-1** to **1312-9** are provided to impose an additional loss on channels input to filtering elements **1314-1** to **1314-9**. The amount of attenuation for each attenuator is typically selected based on the number of filtering elements separating the attenuator from output fiber **1316**. For example, the attenuation of attenuator **1312-1** is less than that of attenuators **1312-2** to **1312-9** because optical signals passing through attenuator **1312-1** will incur further loss passing through filtering elements **1314-2** to **1314-9**. In contrast, since optical signals output from com-

biner **1310-10** do not pass through a series of dielectric filters and thus experience relatively little loss, the attenuation associated with attenuator **1312-9** is greater than that of the remaining attenuators so that substantially uniform optical power can be achieved for each channel output on fiber **1316**. Optionally, an attenuator may be provided at the output of combiner **1310-1**, if necessary.

Optical attenuator **1312-1** will next be described with reference to FIGS. **15** and **16**. It is understood that optical attenuators **1312-2** to **1312-9** typically have a similar construction. Moreover, the structure of optical attenuator **1312-1** is exemplary, and other optical attenuator configurations are considered within the scope of the invention.

As seen in FIG. **16**, optical attenuator **1312-1** includes two optical fibers **1610** and **1620** joined at respective end portions. As further shown in FIG. **15**, which is a cross-sectional view of optical attenuator **1312-1** taken along line **1630**, fibers **1610** and **1620** further include core regions **1520** and **1510**, and cladding regions **1530** and **1540**, as commonly understood. Generally, the refractive indices of the core and cladding are selected so that light propagating through fibers **1610** and **1620** is confined to the cores thereof. In addition, the cores and claddings of both fibers are typically provided about respective axes, as is generally known.

As further shown in FIGS. **15** and **16**, the axes and thus the cores of fibers **1610** and **1620** are offset from one another by a distance d . Thus a portion of light passing from fiber **1620** to fiber **1610**, for example, is dispersed at interface **1635** of the two fibers, while the remaining portion of the light passes through fiber **1610**. As a result, light transmitted through interface **1635** experiences loss, and is thus attenuated. The amount of attenuation is determined by offset d ; a relatively small offset distance d yields less attenuation while a greater offset distance provides more attenuation.

Typically, offset distance d is adjusted for each of attenuators **1312-1** to **1312-9** so that a different attenuation can be obtained for each attenuator, and as discussed above, substantially equalized optical power can be achieved for each channel output from multiplexer **1300**.

Typically, fibers **1610** and **1620** are fusion spliced, so that outer surfaces of these fibers are smooth and continuous at interface **1630**, as shown in FIG. **17**. The cores of the fibers, however, remain offset to provide a desired attenuation, as discussed above.

Multiplexer **1300** has a relatively simple construction and does not require couplers, as is the case with multiplexer **1200** discussed above with reference to FIG. **12**.

Turning now to FIG. **18**, there is shown a multiplexer **1800**, in accordance with a further aspect of the invention, which includes an exemplary dynamic equalization system including a plurality of variable optical attenuators controlled by feedback signals from an output monitor. Optical multiplexer **1800** is shown multiplexing 80 channels, but dynamic equalization consistent with the present invention can be provided in a device for appropriately processing any number of channels.

In the illustrated exemplary embodiment, multiplexer **1800** includes a plurality of conventional 1x8 combiners **1810-1** to **1810-10**, each having eight inputs receiving a respective one of eight channels of an 80-channel system. Combiners **1810-1** to **1810-10** can include one or more of the following: dielectric filters, fiber couplers, planar waveguides, arrayed waveguide routers, and appropriate combinations of fiber Bragg gratings and circulators. Combiners **1810-1** to **1810-10** combine the received channels onto corresponding outputs, which are coupled to respective conventional variable optical attenuators **1812-1** to **1812-10**.

The outputs of the variable optical attenuators **1812-1** to **1812-80** are provided to a combiner **1814**. The combiner may include a series of optical filter elements, as shown, for example in FIG. **13**, which generally receive optical signal inputs from corresponding optical attenuators **1812-1** to **1812-10** and add these signals to signals input from a preceding optical filter element. It is to be understood, however, that a dynamic equalization system consistent with the invention may be incorporated into a multiplexer having a combiner **1814** constructed in any manner consistent with the present invention, or, alternatively, in a manner known in the art.

The output of the combiner comprises the aggregation of channels, λ_1 to λ_{80} , and is typically provided on a single output fiber **1816** as an input to a conventional optical amplifier **1818**, e.g. a rare earth doped fiber amplifier. The amplifier is provided for amplifying the aggregated channels λ_1 to λ_{80} approximately to a level that is appropriate for achieving reliable detection of the aggregated channels at a receiver or further amplifier site downstream therefrom. As noted above with respect to FIG. **13**, different groupings of channels can experience varying degrees of loss when combined onto a single fiber, particularly when a multiplexer, such as that shown in FIG. **13** is used. Accordingly, as further noted above, in systems without an equalization system, it has been found that each of the aggregated bands λ_1 to λ_8 , λ_9 to λ_{16} , . . . λ_{73} to λ_{80} , for example, may be at a different optical signal powers at the output of the combiner. Since the gain spectrum of a downstream amplifier can be non-uniform, variations in the band optical signal powers can result in degraded system performance, often seen as increased bit-error-rates.

To mitigate the adverse effects of optical signal power variation in the aggregated channels, the output of the amplifier on line **1820** may be provided as an input to a conventional gain flattening filter **1822**, which typically includes a dielectric filter configured to selectively attenuate various channels to thereby offset unequal channel powers output from amplifier **1818**. As a result, the output of the gain flattening filter on line **1824** comprises the aggregated signal bands with approximately equalized optical signal powers. It has been recognized, however, that the output signal power of the gain-flattening filter too may vary as a function of wavelength, but is approximately constant within a single band of channels.

Consistent with the invention, therefore, an optical tap **1833**, including a conventional optical splitter, supplies 1–5% of the optical power from filter **1822** to an optical performance monitor circuit **1826** for detecting the optical signal power, and optionally the optical signal to noise ratios, at each band of channels. Based on the detected signal powers and/or signal to noise ratios, the monitor **1826** is configured to generate suitable feedback signals to control the attenuation levels of the variable optical attenuators **1812-1** to **1812-10** for dynamically equalizing the optical signal powers of the bands in the aggregated signal. The present embodiment differs from the embodiment described above in that variable optical attenuators **1812-1** to **1812-10** are provided instead of fixed attenuators **1312-1** to **1312-9** discussed above.

A variety of monitor configurations for providing a feedback signal are possible. For example, the monitor may include a conventional optical spectrum analyzer **1830** and a processor circuit **1832** appropriately programmed or otherwise configured for generating the feedback signals, as illustrated in FIG. **18**. In addition, the feedback signals may be provided through a hard-wire connection, e.g. on lines

1828-1 to **1828-10**, as shown, or may be provided to the attenuators through a telemetry channel.

Advantageously, feedback from the monitor **1826** to the variable optical attenuators **1812-1** to **1812-10** facilitates dynamic equalization of the optical signal power levels of each band in the aggregate output on line **1834**. The adverse effects of wavelength-dependent variations in the output of the amplifier and the gain-flattening filter are thereby substantially eliminated, resulting in improved system performance. Although the advantages of dynamic equalization consistent with the invention may be applied to a wide variety of optical systems, it is particularly advantageous in high channel count, high bit rate, and long distance systems. Also, it is to be understood that in some applications, e.g. in applications with relatively low channel-count, the amplifier and/or the gain-flattening filter may not be necessary.

FIG. **19** illustrates an exemplary demultiplexer **1900** including a dynamic equalization system consistent with the invention. As shown, input to the demultiplexer comprises an aggregation of channels, e.g. λ_1 to λ_{80} , and may be provided on a single input fiber **1940** as an input to a conventional optical amplifier **1918**, e.g. a rare earth doped fiber amplifier. The amplifier is provided for amplifying the aggregated channels approximately to a level that is appropriate for achieving reliable detection of the aggregated channels at a receiver or amplifier site (not shown).

The output of the amplifier on optical path **1942** may be provided as an input to a conventional gain flattening filter **1922**. The output of the gain-flattening filter comprises the aggregated signal with approximately equalized optical channel powers. Again, the output signal power of the amplifier and the gain flattening filter varies as a function of wavelength, but is approximately constant within single bands of channels.

To equalize the optical signal powers of the bands, an optical tap **1933**, similar to tap **1833**, is coupled to filter **1922** to supply the optical performance monitor **1926** with a portion of the output from filter **1922** for detecting the optical signal power, and optionally the optical signal to noise ratios, at each band of channels. The output of the monitor **1926** is coupled to an optical demultiplexer or separator **1944**. The separator separates aggregated channels into channel bands λ_1 to λ_8 , λ_9 to λ_{16} , . . . λ_{73} to λ_{80} on separate outputs, which are coupled to respective corresponding variable optical attenuators **1912-1** to **1912-10**. The attenuators provide the bands to the inputs of corresponding channel separators **1946-1** to **1946-10**, which separate the respective bands into their constituent optical channels.

Advantageously, based on the detected signal powers and/or signal to noise ratios of the individual bands in the aggregated signal, the monitor **1926** is configured to generate suitable feedback signals, e.g. on lines **1928-1** to **1928-10** or by telemetry, to corresponding variable attenuators to control the attenuation levels of the variable optical attenuators. The outputs of the respective variable optical attenuators are thereby dynamically equalized. The adverse effects of wavelength-dependent variations in the output of the amplifier and the gain-flattening filter are thereby substantially eliminated, resulting in improved system performance.

Dynamic equalization using an optical performance monitor to control band attenuation level through variable optical attenuators consistent with the invention may be incorporated into a variety of optical devices in addition to multiplexers and demultiplexers. As illustrated in FIG. **20**, for example, dynamic equalization may be provided in an

amplifier network element **2000** coupled to a fiber optic span between end terminals (not shown). In an amplifier configuration, the aggregated signal, e.g. λ_1 to λ_{80} , would be provided at an input to a demultiplexer or separator **2044** for separating the aggregated signal into individual bands λ_1 to λ_8 , λ_9 to λ_{16} , . . . λ_{73} to λ_{80} on corresponding outputs coupled to corresponding variable optical attenuators **2012-1** to **2012-10**. The outputs of the attenuators may be provided to a combiner **2014** to aggregate the bands on an output optical signal path **2050** coupled to a conventional optical amplifier **2018**. The output of the amplifier may be provided to a conventional gain flattening filter **2022**, and a portion thereof, e.g., 1-5%, provided to performance monitor **2026** via tap **2033**, for monitoring purposes and generating control signals for variable attenuators **2012-1** to **2012-10** in a manner similar to that described above with reference to FIGS. **18** and **19**.

The optical signal powers of the bands are substantially equalized in the manner described above with respect to the exemplary multiplexer configuration of FIG. **18**. The optical performance monitor **1826** at the output of the amplifier detects the output optical power of each band provides a feedback signal, e.g. on lines **2028-1** to **2028-10** or by telemetry, to each corresponding variable optical attenuator **2012-1** to **2012-10**. The attenuation level of the attenuators is adjusted based on the feedback signal to achieve substantially equalized optical power in the aggregated signal on line **2050** coupled to the amplifier **2018**.

While the foregoing invention has been described in terms of the embodiments discussed above, numerous variations are possible. Accordingly, modifications and changes such as those suggested above, but not limited thereto, are considered to be within the scope of the following claims.

What is claimed is:

1. An optical apparatus comprising:

a plurality of separate optical paths, each of which receiving a separate group of optical signals;

a plurality of variable optical attenuators, each of which having an input coupled to an associated one of said separate optical paths;

an optical combiner having separate inputs, each of which coupled to an output of an associated one of said variable optical attenuators, said optical combiner having an output providing said separate groups of optical signals in an aggregated form on an aggregate optical signal path; and

an optical performance monitor coupled to said aggregate optical signal path, said optical performance monitor being configured to detect a plurality of optical signal to noise ratios, each of which being associated with a respective one of said separate groups and to supply a feedback signal to corresponding ones of said variable optical attenuators for adjusting a respective attenuation associated with each of said attenuators in response to the detected plurality of optical signal to noise ratios.

2. An optical apparatus according to claim **1**, wherein said device further comprises a plurality of first optical combiners, each of which being coupled to an associated one of said optical paths for supplying a respective one of said separate groups of optical signals.

3. An optical apparatus according to claim **1**, wherein said device further comprises an optical demultiplexer, said optical demultiplexer having a plurality of outputs, each of which being coupled to an associated one of said optical paths for supplying a respective one of said separate groups of optical signals.

15

4. An optical apparatus according to claim 1, wherein said device further comprises an optical amplifier coupled to an output of said optical combiner.

5. An optical apparatus according to claim 1, wherein said device further comprises a filter coupled to said aggregate optical signal path, said filter having an output coupled to an input of said optical performance monitor.

6. An optical apparatus according to claim 1, wherein said combiner comprises a plurality of cascaded optical filters, each of said optical filters having an input coupled to an output of an associated one of said variable optical attenuators.

7. An optical apparatus according to claim 1, wherein said optical performance monitor circuit comprises an optical spectrum analyzer for detecting said plurality of optical signal to noise ratios and a processor circuit for supplying said feedback signals.

8. An optical apparatus according to claim 1, said optical performance monitor being configured to detect a plurality of optical signal to noise ratios and optical powers, each of which being associated with a respective one of said separate groups and to supply a feedback signal to corresponding ones of said variable optical attenuators for adjusting a respective attenuation associated with each of said variable optical attenuators in response to said detected plurality of optical signal to noise ratios and optical powers.

9. The optical apparatus according to claim 1, wherein at least one of the groups of optical signals includes only one wavelength division multiplexed channel.

10. An optical apparatus comprising:
 an optical communication path receiving an optical signal including a plurality of separate wavelengths;
 an optical performance monitor coupled to said optical communication path, said optical performance monitor circuit being configured to detect a plurality of optical signal to noise ratios, each of which being associated with a respective one of a plurality of separate groups of said separate wavelengths and to supply separate feedback signals in response to said detected plurality of optical signal to noise ratios;

an optical demultiplexer configured to receive an output of said optical performance monitor circuit, said demultiplexer supplying each of said plurality of groups of said separate wavelengths on a separate associated output; and

a plurality of variable optical attenuators, each of which receiving a separate one of said separate associated outputs, each of said plurality of optical attenuators receiving an associated one of said separate feedback signals for adjusting an associated attenuation level.

11. An optical device apparatus according to claim 10, wherein said device further comprises an optical amplifier coupled to said optical communication path.

12. An optical apparatus according to claim 10 wherein said device further comprises a filter coupled to said optical communication path, said filter having an output coupled to an input of said optical performance monitor.

13. An optical apparatus according to claim 10, wherein said optical performance monitor circuit comprises an opti-

16

cal spectrum analyzer for detecting said optical signal and a processor circuit for supplying said feedback signals.

14. A method for processing optical signals, comprising: providing each of a plurality groups of said optical signals on a respective one of a plurality of separate optical signal paths;

combining each of said groups of optical signals on an aggregate optical signal path;

detecting a plurality of optical signal to noise ratios, each of said plurality of optical signal to noise ratios being associated with a corresponding one of said plurality of groups of optical signals; and

attenuating each group of said plurality of optical signals on said separate optical signal paths in response to a corresponding one of said detected plurality of optical signal to noise ratios.

15. A method for processing optical signals according to claim 14,

said detecting step detecting a plurality of optical signal powers and optical signal to noise ratios, each of said optical signal powers and said optical signal to noise ratios being associated with a corresponding one of said plurality of groups of optical signals,

said attenuating step attenuating each group of said plurality of optical signals on said separate optical paths in response to corresponding ones of the optical signal powers and optical signal to noise ratios.

16. A method for processing optical signals according to claim 14, wherein at least one of the groups of optical signals includes only one wavelength division multiplexed channel.

17. A method for processing optical signals, comprising: providing each of a plurality of groups of said optical signals in an aggregated form on an optical signal path; detecting plurality of optical signal to noise ratios, each of said plurality of optical signal to noise ratios being associated with a corresponding one of said plurality of groups of optical signals; separating said groups of optical signals onto associated separate optical signal paths; and

attenuating each group of said plurality of optical signals on said separate optical signal paths in response to a corresponding one of said detected plurality of optical signal to noise ratios.

18. A method for processing optical signals according to claim 17,

said detecting step detecting a plurality of optical signal powers and optical signal to noise ratios, each of said optical signal powers and said optical signal to noise ratios being associated with a corresponding one of said plurality of groups of optical signals,

said attenuating step attenuating each group of said plurality of optical signals on said separate optical paths in response to corresponding ones of said optical signal powers and optical signal to noise ratios.

19. A method for processing optical signals according to claim 17, wherein at least one of the groups of optical signals includes only one wavelength division multiplexed channel.