



(19) **United States**

(12) **Patent Application Publication**  
**Shimpi et al.**

(10) **Pub. No.: US 2022/0136471 A1**

(43) **Pub. Date: May 5, 2022**

(54) **ELECTRONIC FILTER DETECTION  
FEATURE FOR LIQUID FILTRATION  
SYSTEMS**

*F02M 37/40* (2019.01)

*F02M 35/024* (2006.01)

*B01D 46/42* (2006.01)

(71) Applicant: **Cummins Filtration IP, Inc.**,  
Columbus, IN (US)

*F02D 41/22* (2006.01)

*F01M 13/04* (2006.01)

*F02D 41/26* (2006.01)

(72) Inventors: **Abhijit Shimpi**, Nashville, TN (US);  
**Joseph Okoro**, Columbus, IN (US);  
**Andry Lesmana**, Columbus, IN (US);  
**Abhijeet Vaidya**, Columbus, IN (US);  
**Adaeze Okoye**, Indianapolis, IN (US);  
**John T. Carroll, III**, Columbus, IN  
(US); **Matthew L. Schneider**, Seymour,  
IN (US); **Barry M. Verdegan**,  
Stoughton, WI (US); **Chad M.  
Thomas**, Cookeville, TN (US)

*B01D 17/12* (2006.01)

*B01D 35/143* (2006.01)

*F01P 11/06* (2006.01)

*H04B 7/24* (2006.01)

(52) **U.S. Cl.**

CPC ..... *F02M 37/28* (2019.01); *H04B 7/24*  
(2013.01); *B01D 35/005* (2013.01); *B01D*  
*37/025* (2013.01); *F02M 37/40* (2019.01);  
*F02M 35/024* (2013.01); *B01D 37/02*  
(2013.01); *B01D 46/429* (2013.01); *F02D*  
*41/22* (2013.01); *F01M 13/04* (2013.01);  
*F02D 41/26* (2013.01); *B01D 17/12*  
(2013.01); *B01D 35/143* (2013.01); *F01P*  
*11/06* (2013.01); *B01D 2201/56* (2013.01);  
*B01D 2201/54* (2013.01); *F01M 2013/0438*  
(2013.01); *B01D 37/00* (2013.01)

(73) Assignee: **Cummins Filtration IP, Inc.**,  
Columbus, IN (US)

(21) Appl. No.: **17/575,362**

(22) Filed: **Jan. 13, 2022**

**Related U.S. Application Data**

(63) Continuation of application No. 17/202,835, filed on  
Mar. 16, 2021, which is a continuation of application  
No. 16/220,481, filed on Dec. 14, 2018, now Pat. No.  
11,015,556, which is a continuation of application  
No. 15/029,442, filed on Apr. 14, 2016, now Pat. No.  
10,184,415, filed as application No. PCT/US14/  
60888 on Oct. 16, 2014.

(60) Provisional application No. 61/891,593, filed on Oct.  
16, 2013.

**Publication Classification**

(51) **Int. Cl.**

*F02M 37/28* (2019.01)

*B01D 37/00* (2006.01)

*B01D 35/00* (2006.01)

*B01D 37/02* (2006.01)

(57)

**ABSTRACT**

A filter monitor system (“FMS”) module is installed on the engine/vehicle and is connected to the filter systems, sensors and devices to monitor various performance parameters. The module also connects to the engine control module (“ECM”) and draws parameters from the ECM. The FMS module is capable of interfacing with various output devices such as a smartphone application, a display monitor, an OEM telematics system or a service technician’s tool on a computer. The FMS module consists of hardware and software algorithms which constantly monitor filter systems and provide information to the end-user. FMS module provides necessary inputs and outputs for electronic sensors and devices.

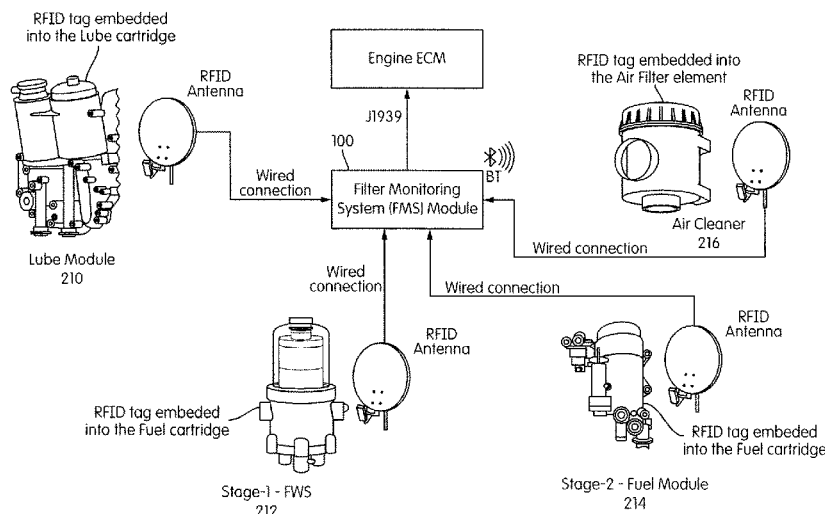

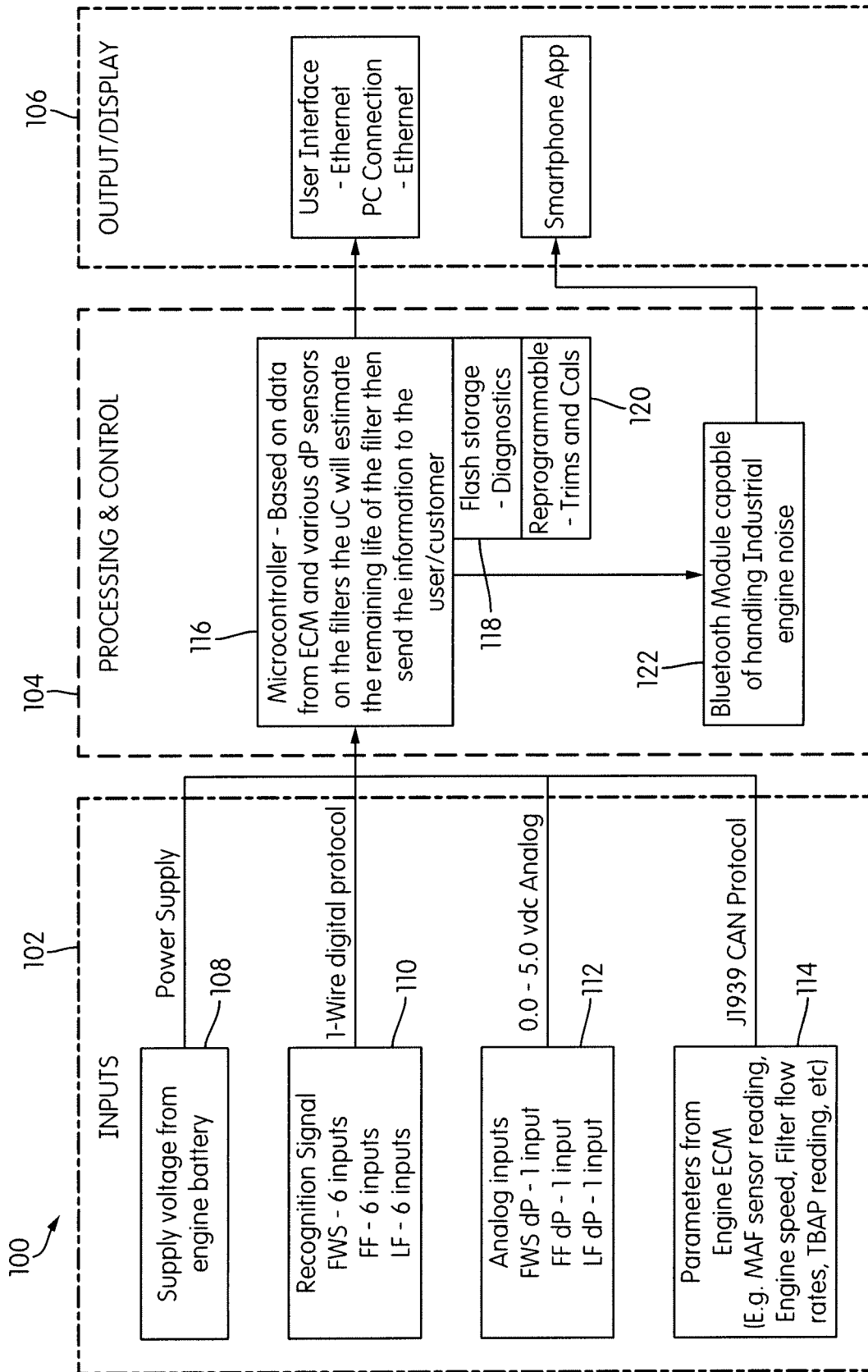

FIG. 1

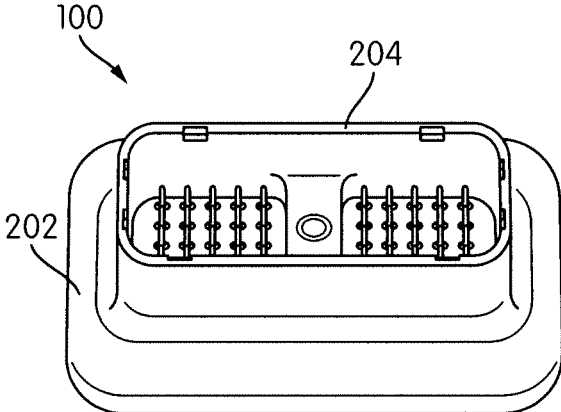

FIG. 2A

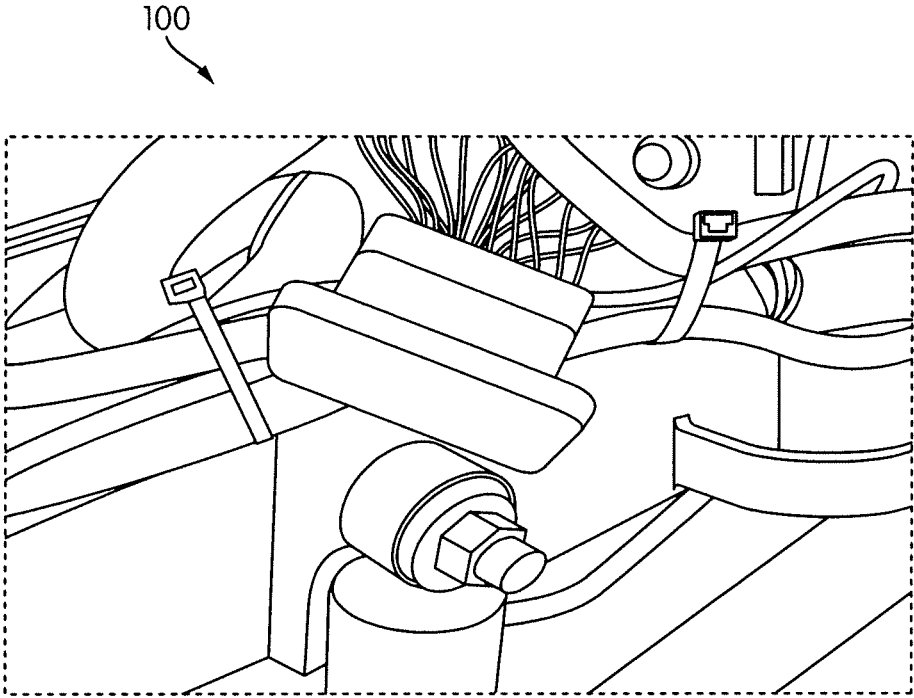

FIG. 2B

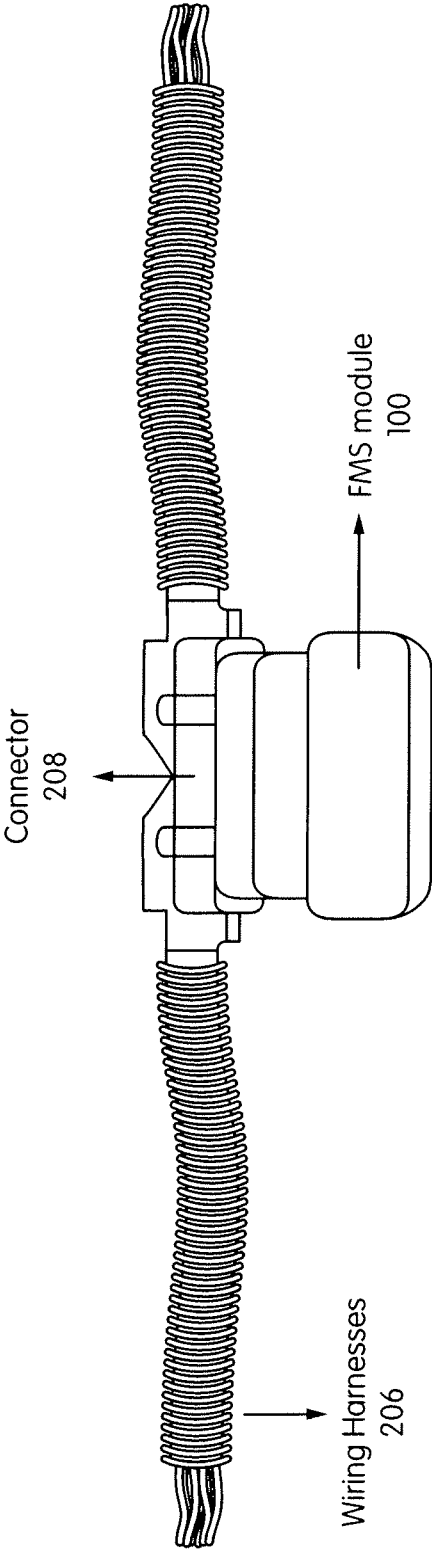

FIG. 2C

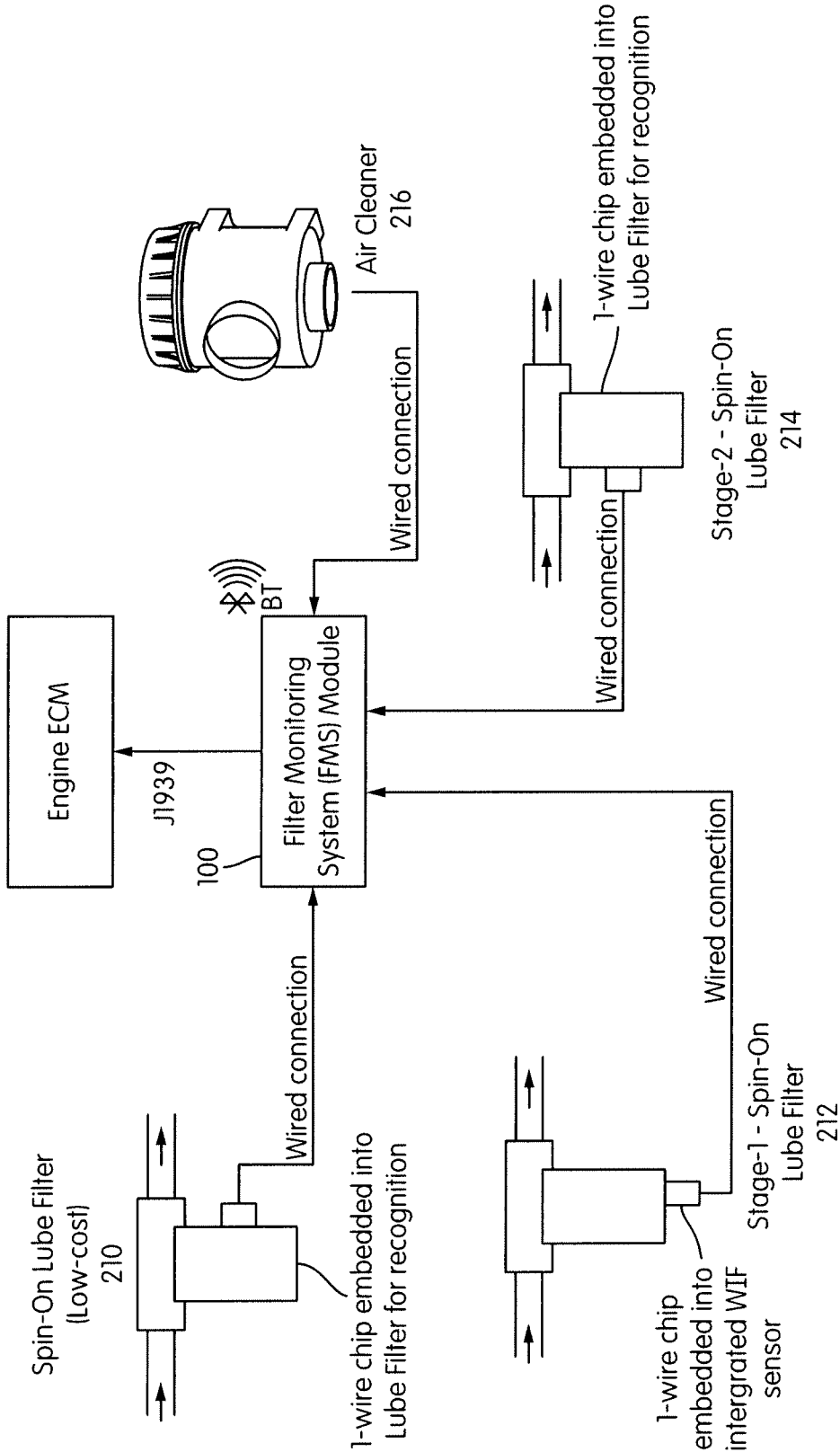

FIG. 2D

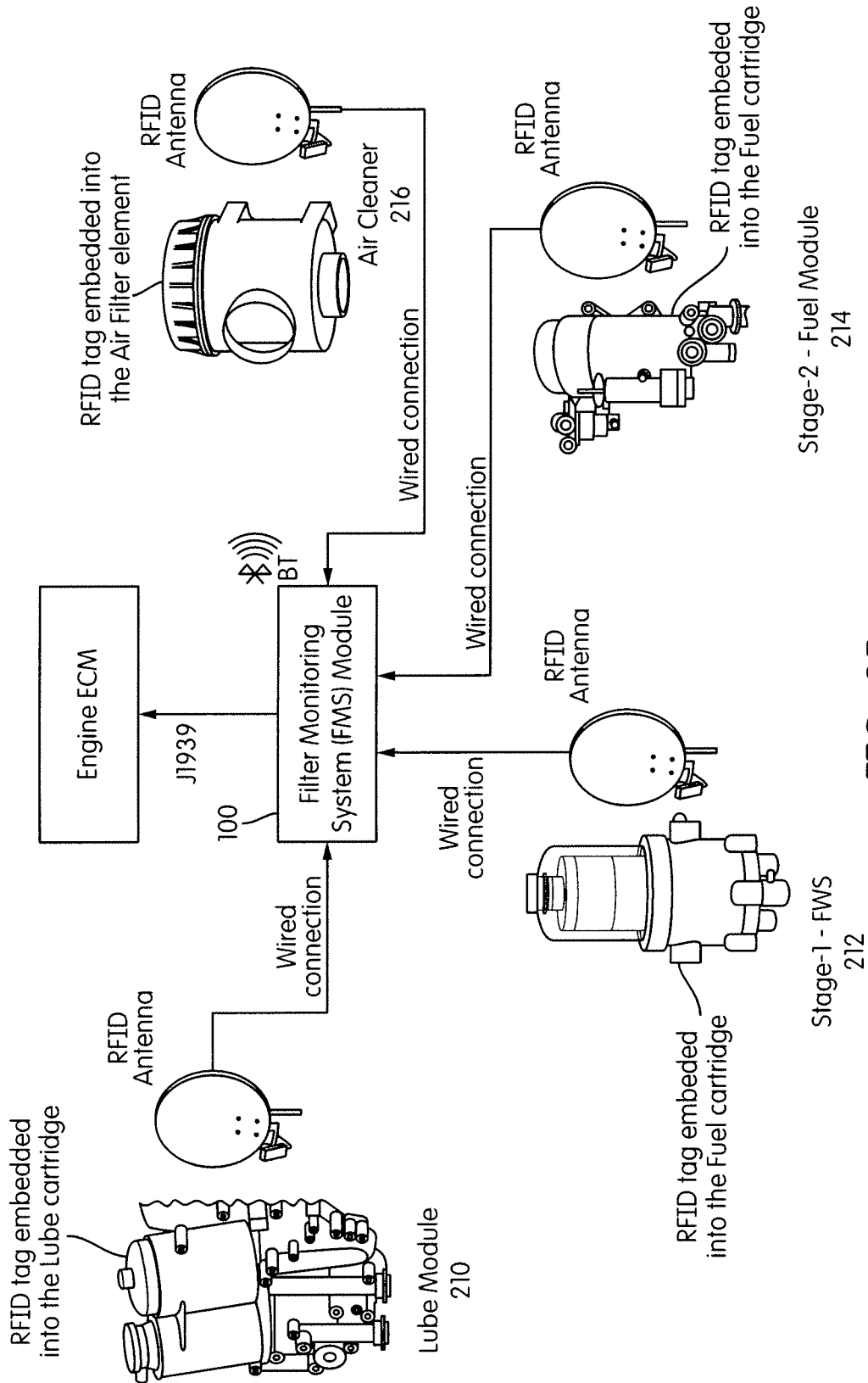

FIG. 2E

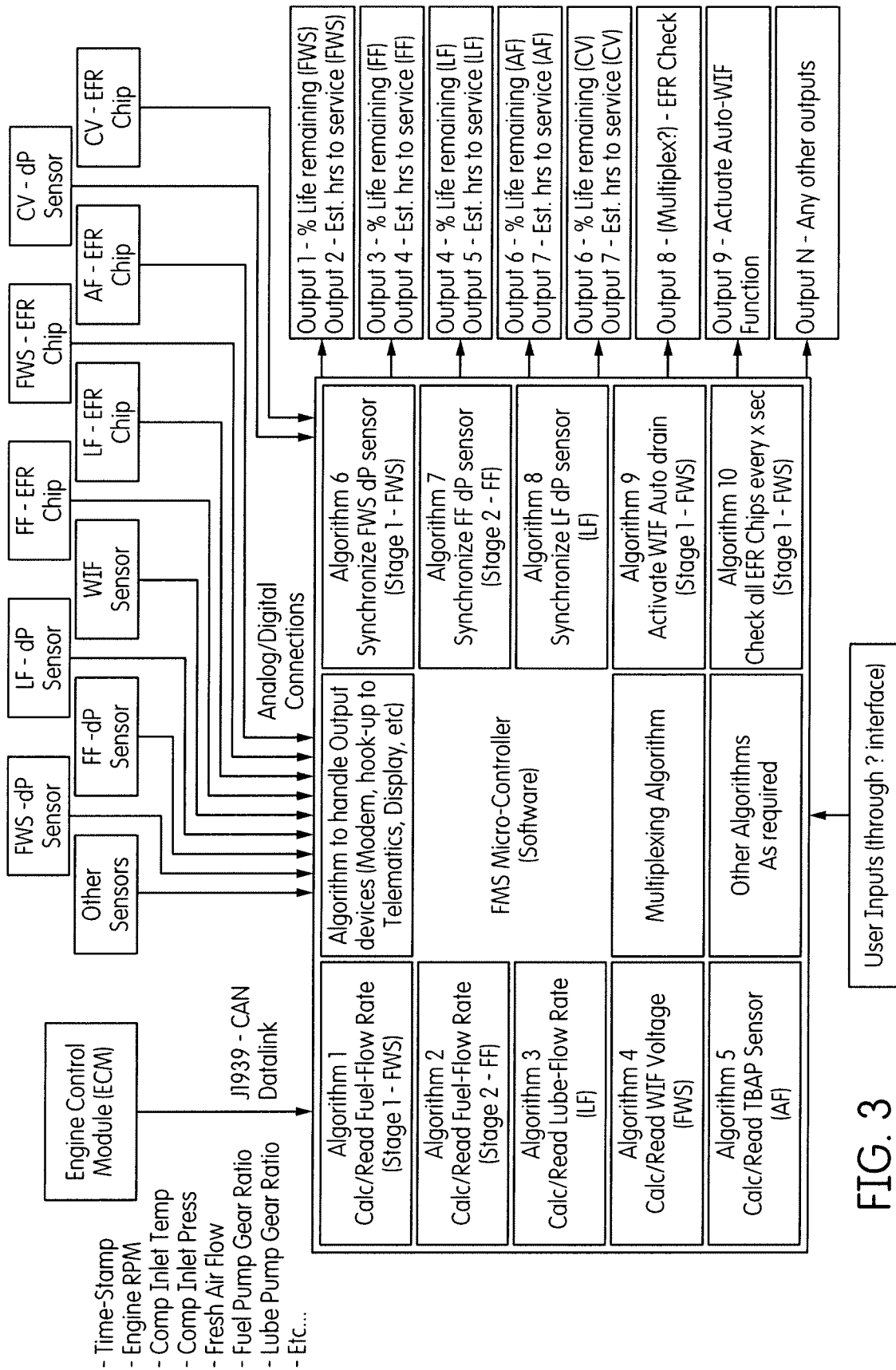
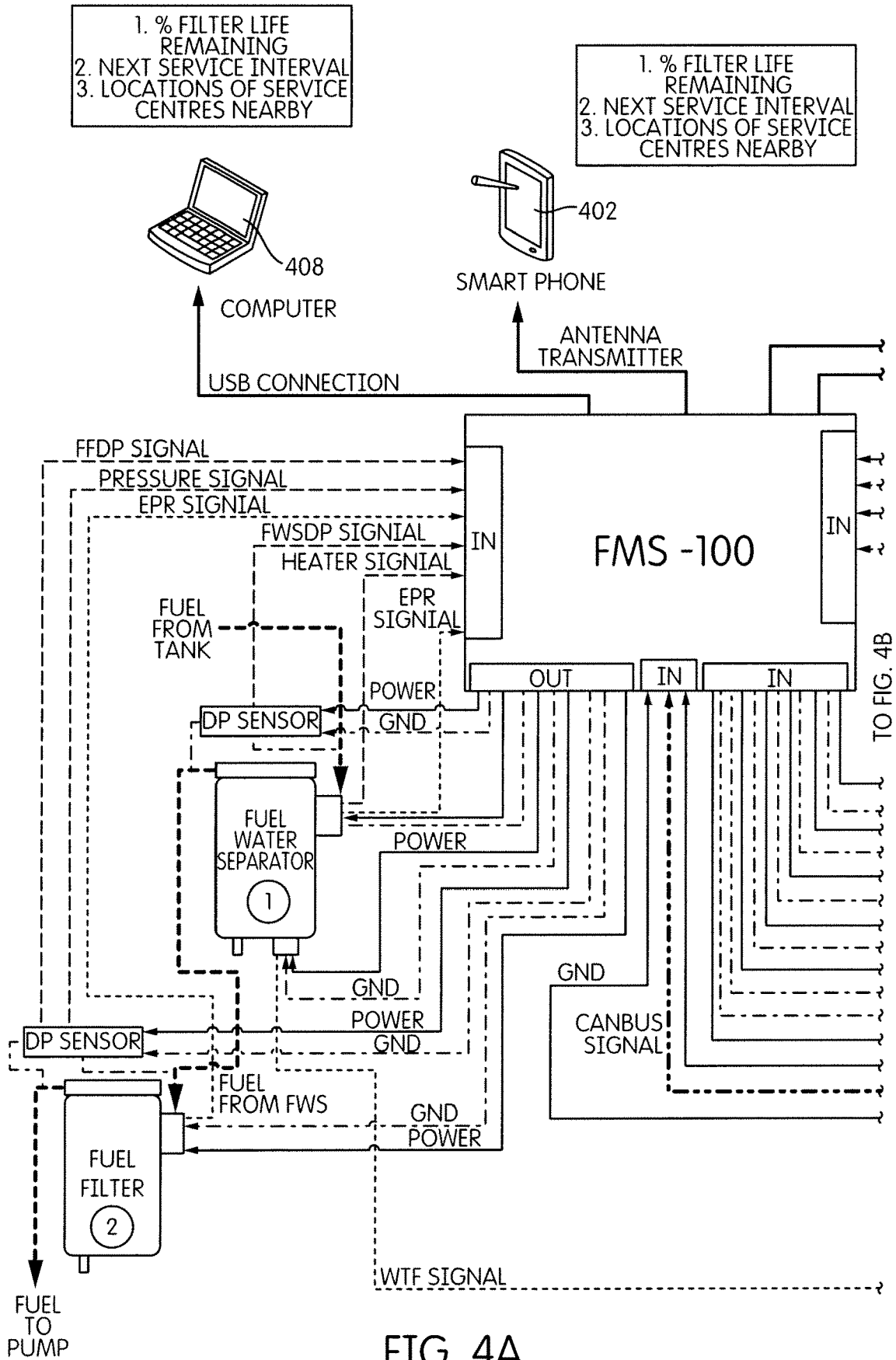
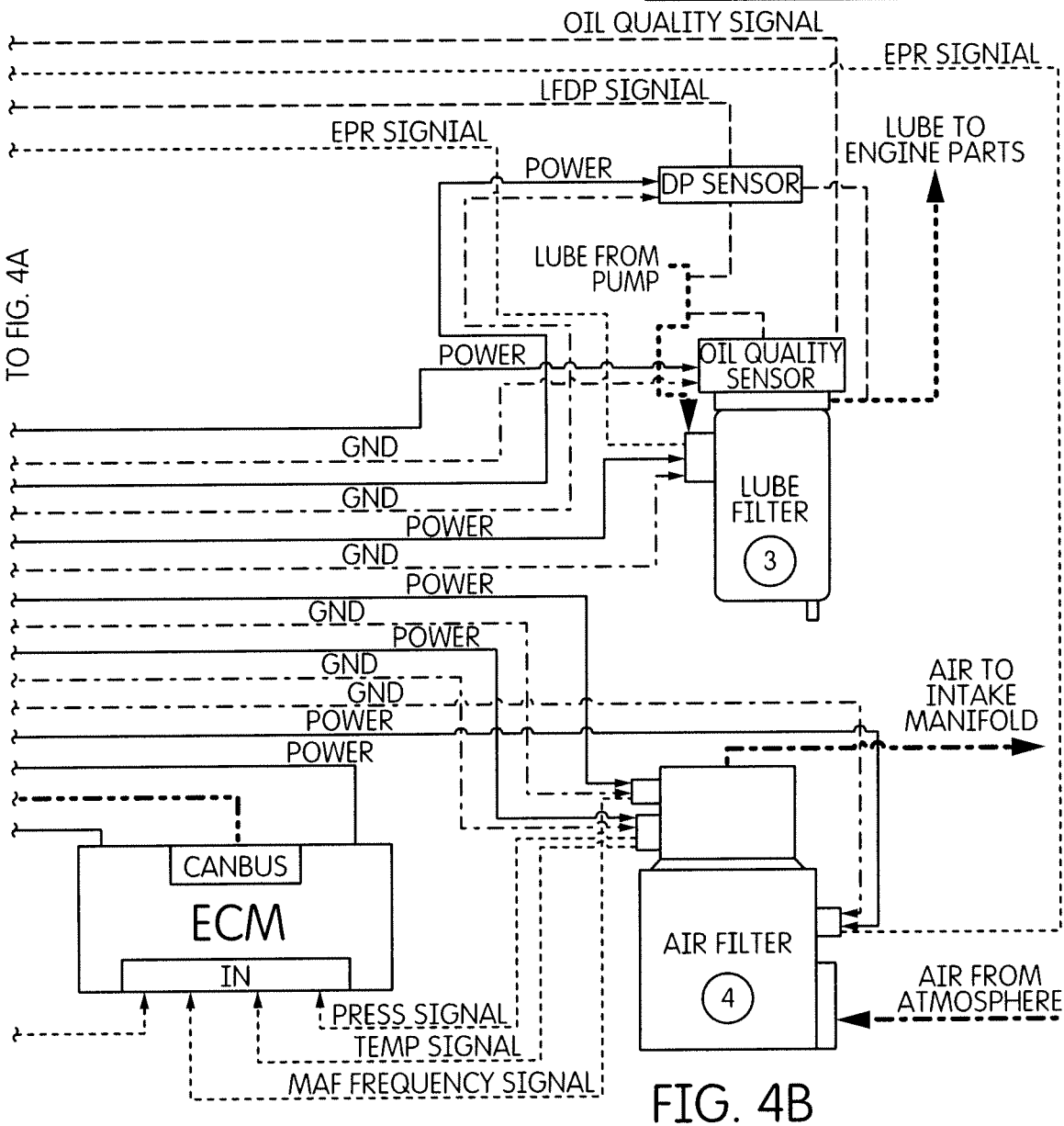
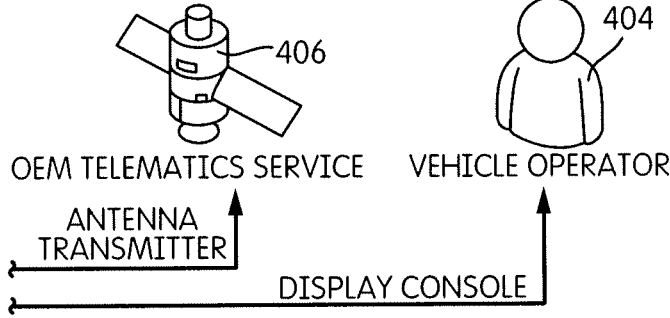
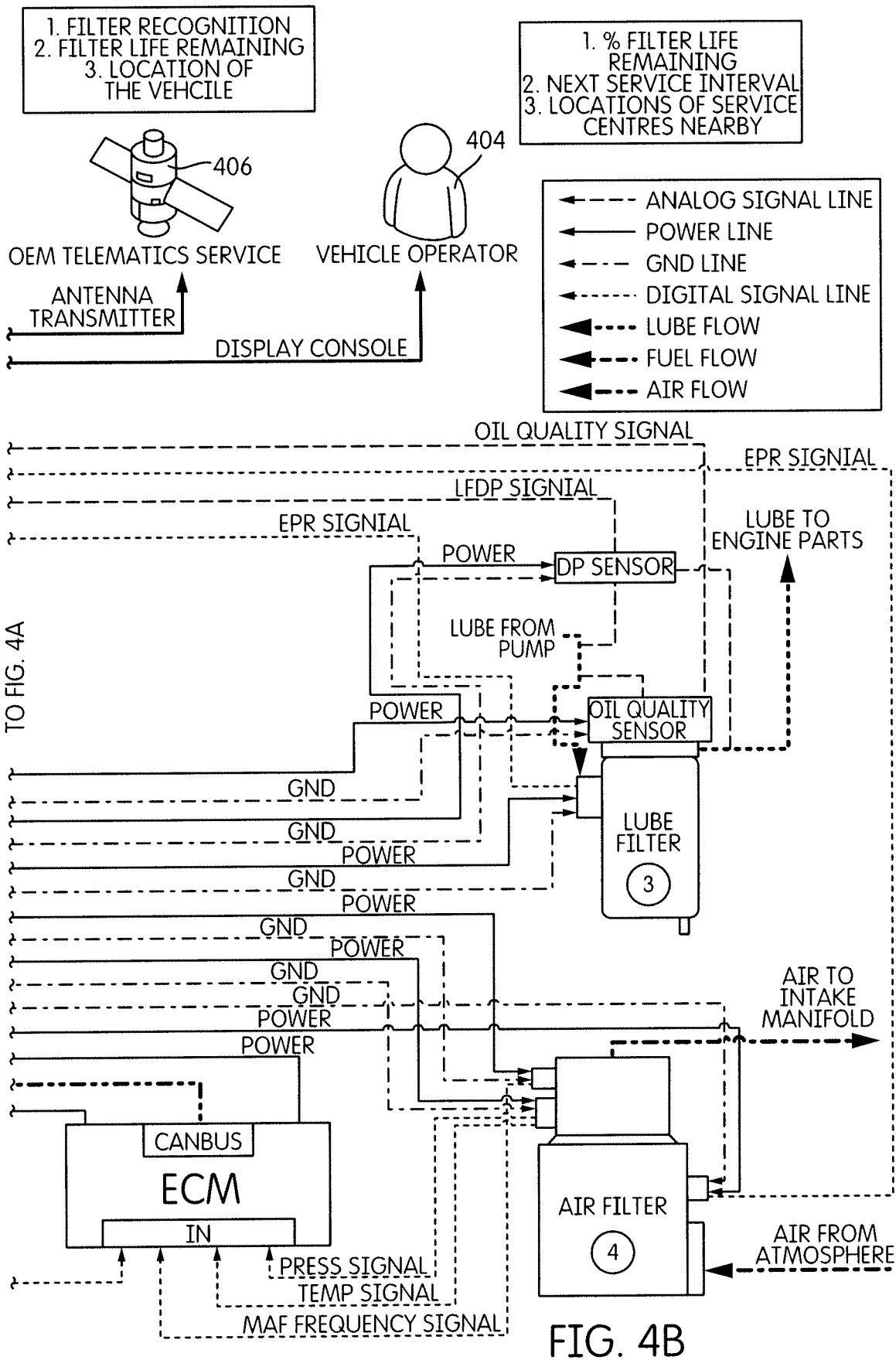

FIG. 3







500

FMS Module  
Output table

	FWS	FF	LF	AF	ECM
Timestamp (app <-> FMS)	18-Jan-2013, 11:44 AM	18-Jan-2013, 11:44 AM	18-Jan-2013, 11:44 AM	18-Jan-2013, 11:44 AM	18-Jan-2013, 11:44 AM
EFR Check	Yes/No/ No Connection	Yes/No/ No Connection	Yes/No/ No Connection	Yes/No/ No Connection	N/A
dP value	10 psid/Not Available	12 psid/Not Available	22 psid/Not Available	27 inch/Not Available	N/A
% loading	% loading	% loading	% loading	% loading	N/A
Last Service Date	18-Oct-2012	18-Oct-2012	07-Jun-2012	23-Jan-2012	N/A
dP Sensor status	OK/not OK/ Not Connected	OK/not OK/ Not Connected	OK/not OK/ Not Connected	OK/not OK/ Not Connected	N/A
Filter Part Number	FS1001/Not Available	FF19569/Not Available	LF9027/Not Available	AF25973/Not Available	N/A
WIF indication	Drain/OK/ Not Connected	N/A	N/A	N/A	N/A
Remaining service life (hrs)	137 hours	137 hours	276 hours	345 hours	N/A
Remaining service life (miles)	2572 miles	2572 miles	6998 miles	4523 miles	N/A
Engine ESN	N/A	N/A	N/A	N/A	987234072
Engine Model #	N/A	N/A	N/A	N/A	D03B3007
Engine Life	N/A	N/A	N/A	N/A	19742 hours
Service Life prediction mode	dP based/ Fixed Interval	dP based/ Fixed Interval	dP based/ Fixed Interval	dP based/ Fixed Interval	N/A

FIG. 5

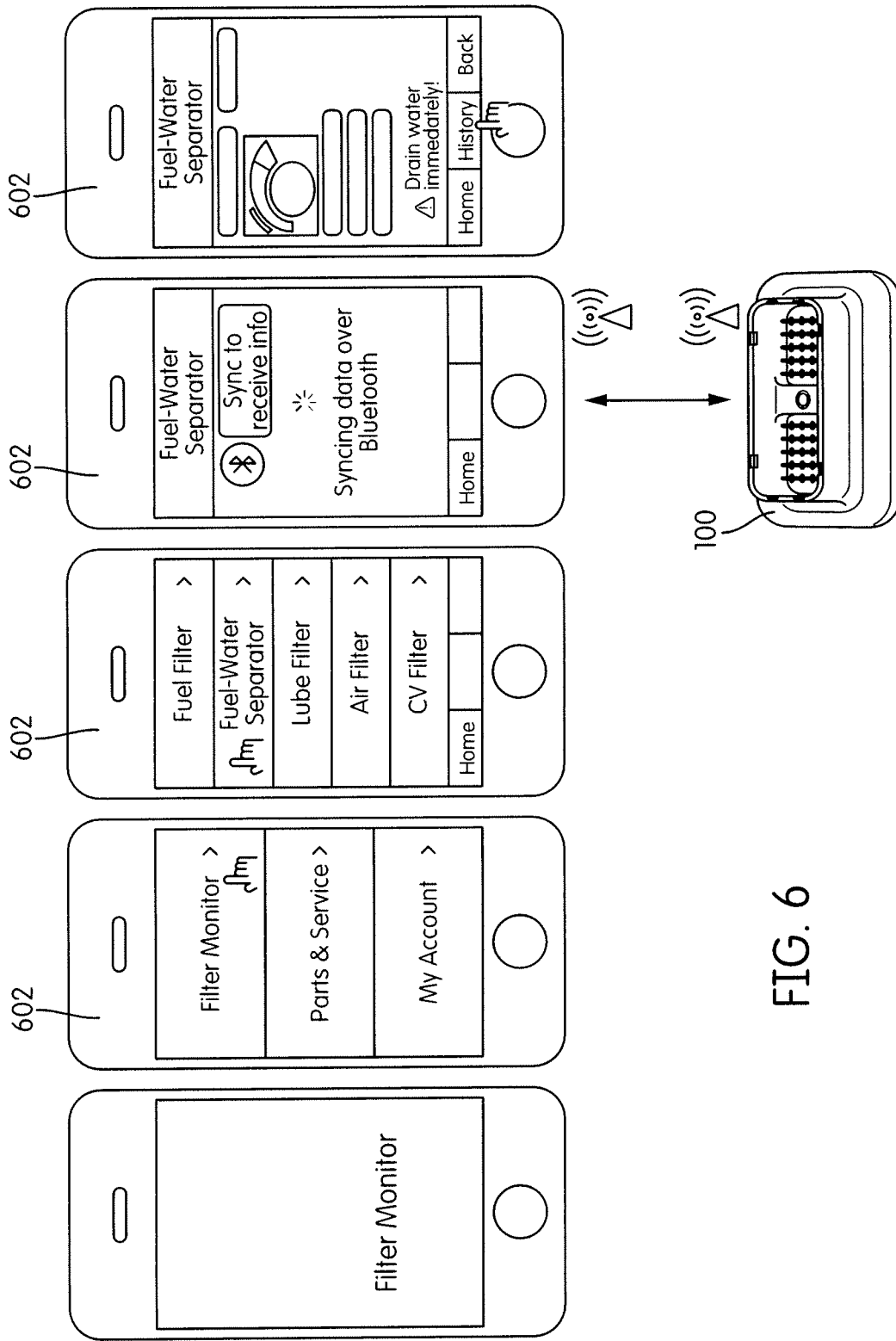
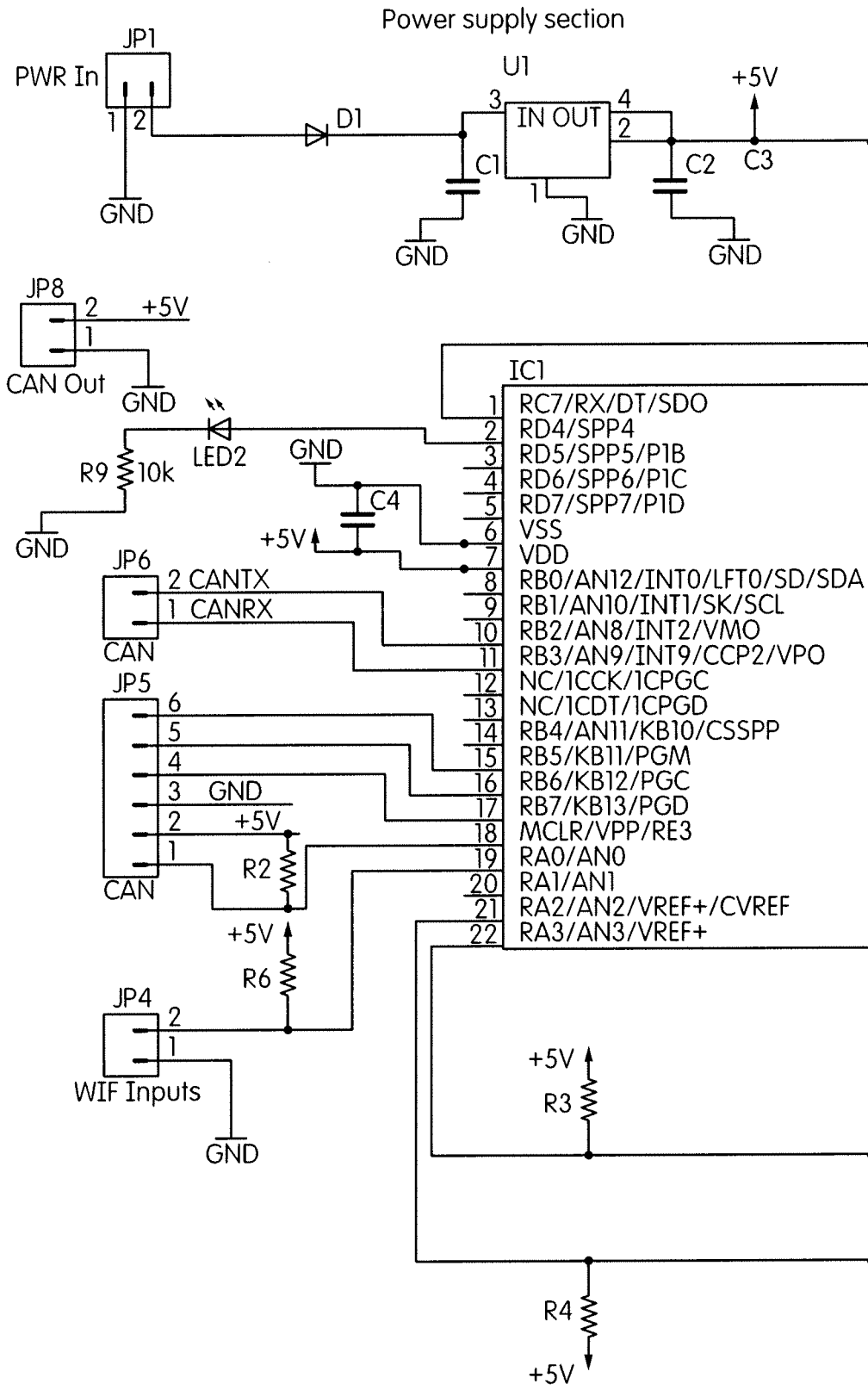

FIG. 6



TO FIG. 7A-2

FIG. 7A-1

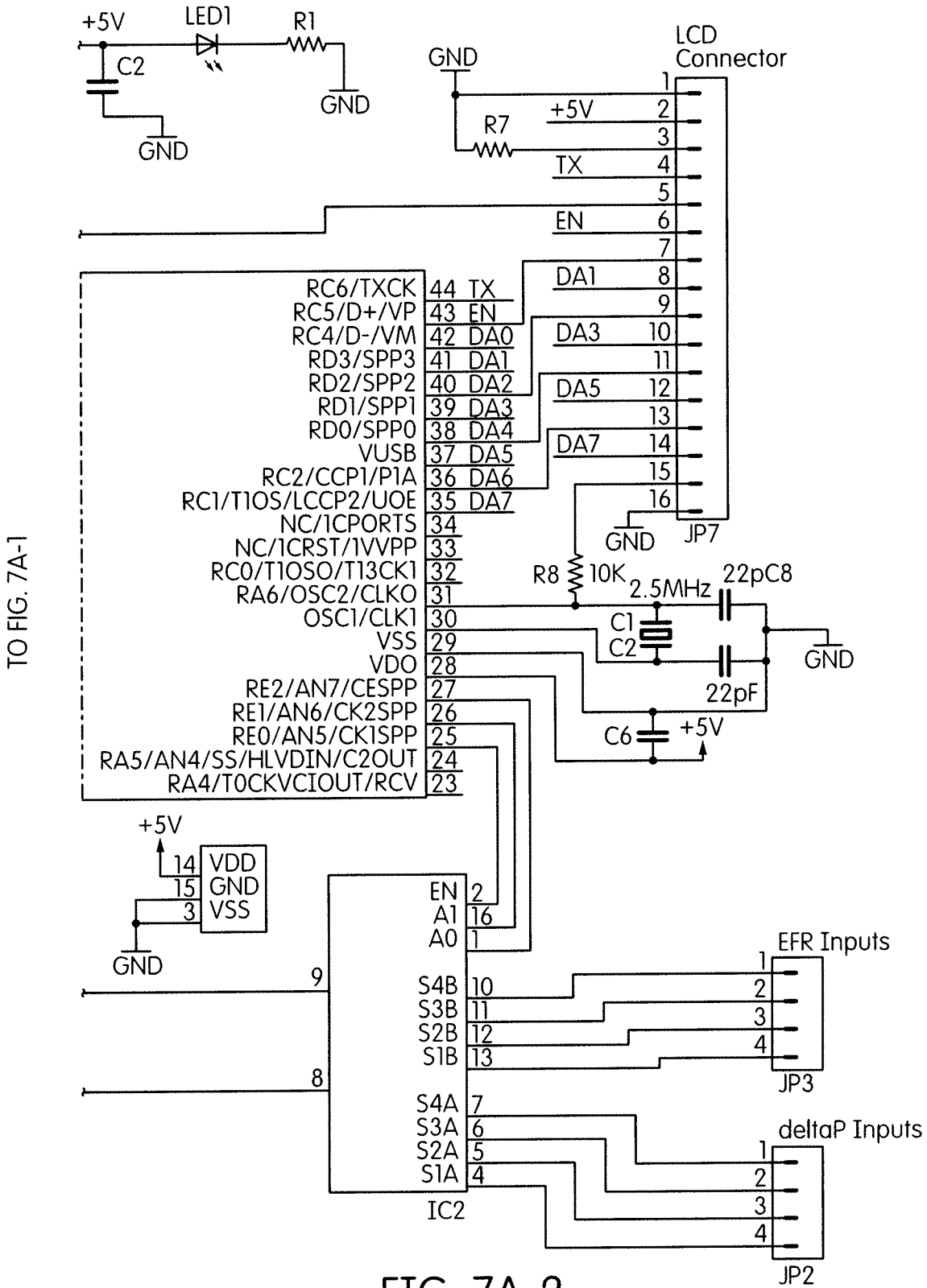

FIG. 7A-2

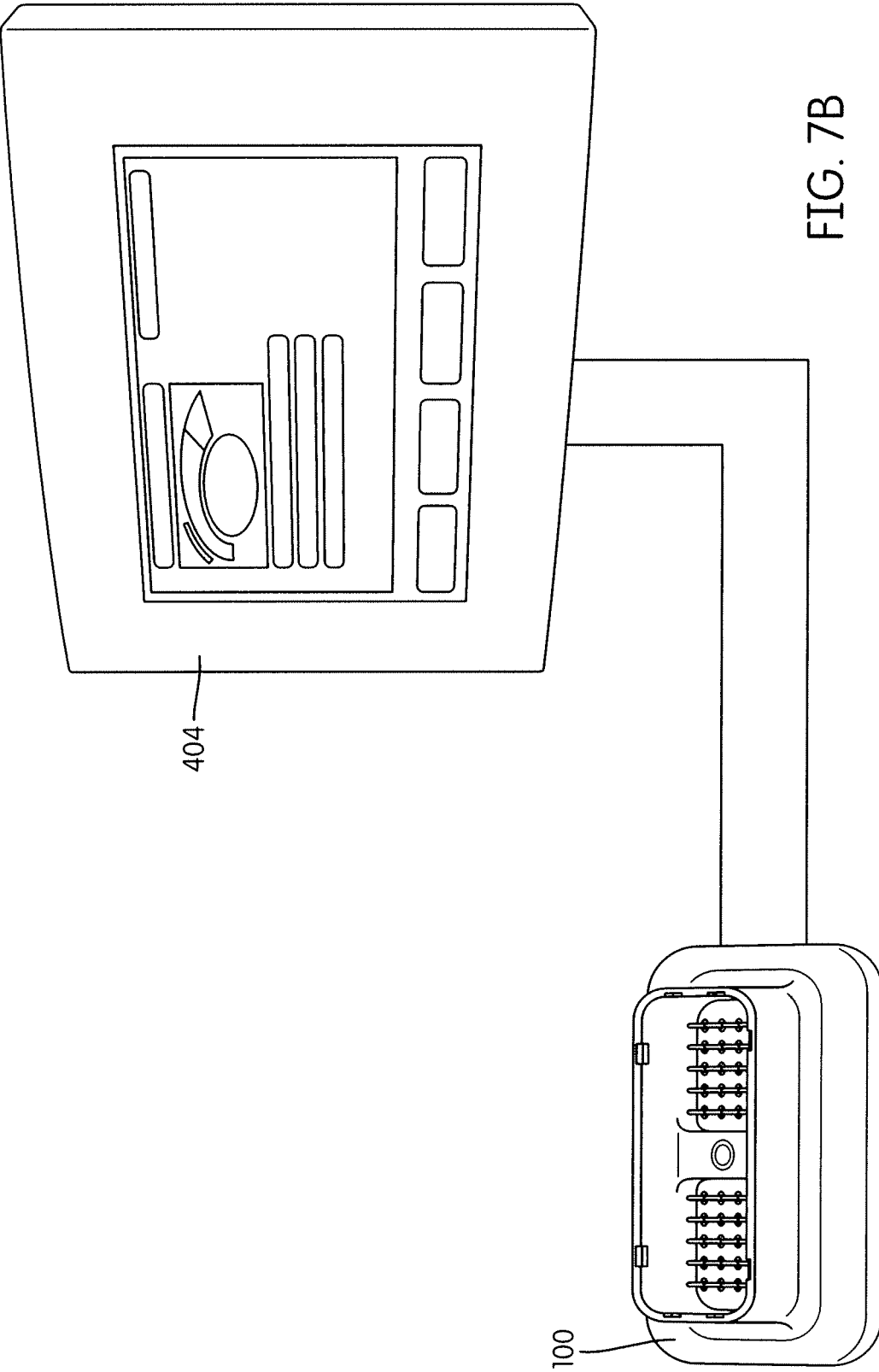

FIG. 7B

## ELECTRONIC FILTER DETECTION FEATURE FOR LIQUID FILTRATION SYSTEMS

### CROSS-REFERENCE TO RELATED APPLICATIONS

**[0001]** This application is a continuation of U.S. patent application Ser. No. 17/202,835. Filed Mar. 16, 2021, which is a continuation of U.S. patent application Ser. No. 16/220,481, filed Dec. 14, 2018, which is a continuation of U.S. patent application Ser. No. 15/029,442, filed Apr. 14, 2016, now U.S. Pat. No. 10,184,415, which issued Jan. 22, 2019, which is a U.S. national stage application claiming the benefit of International Application No. PCT/US2014/060888, filed on Oct. 16, 2014, which claims priority to U.S. Provisional Patent Application No. 61/891,593, entitled “FILTER MONITORING SYSTEMS AND METHODS OF OPERATING FILTER MONITORING SYSTEMS,” filed on Oct. 16, 2013, and by Shimpi et al. The entire contents of these applications are incorporated herein by reference in their entirety.

### FIELD

**[0002]** The present disclosure relates generally to systems for and methods of monitoring filtration systems of internal combustion engines.

### BACKGROUND

**[0003]** On and off-highway commercial vehicles and equipment having internal combustion engines have very high costs of engine and/or machine downtime. The internal combustion engines can have various filtration systems, including air filtration systems, fuel filtration systems, lubricant filtration systems, hydraulic fluid filtration systems, crankcase ventilation filtration systems, coolant filtration systems, and the like. Each filtration system typically includes a filter element that needs to be replaced after a designated amount of use (e.g., a designated amount of engine run time, a designated amount of miles driven, a filter capacity, etc.). Diagnosis of the condition of the engine filter elements will help make important decisions about servicing particular filter elements that are close to usable life or that have already exceeded usable life. Replacing the filter elements helps to prevent damage to the engine systems due to overloaded filters.

**[0004]** It is in the interest of fleet owners to synchronize service events of multiple filter elements to reduce vehicle and equipment downtime. Various filtration system monitoring systems are needed to monitor the various filter elements. Fleets managing multiple vehicles also need to monitor parts inventory (e.g., the number and type of replacement filter elements readily available to use for service). Remote filter monitoring can help making smarter inventory decisions. Current monitoring systems require additional pins available on the engine control module (“ECM”), which is expensive and difficult to implement.

**[0005]** The following U.S. patent applications and patents are all incorporated herein by reference in entirety.

**[0006]** U.S. patent application Ser. No. 13/412,280, filed Mar. 5, 2012, published Oct. 4, 2012 as U.S. Patent Publication No. US 2012/0253595A1.

**[0007]** U.S. Provisional Patent Application Ser. No. 61/810,946, filed Apr. 11, 2013

**[0008]** U.S. Pat. No. 6,207,045, issued Mar. 27, 2001.

**[0009]** U.S. patent application Ser. No. 12/860,499, filed Aug. 20, 2010, now U.S. Pat. No. 8,409,446, issued Apr. 2, 2013.

**[0010]** U.S. patent application Ser. No. 13/827,992, filed Mar. 14, 2013.

**[0011]** U.S. Provisional Patent Application Ser. No. 61/586,603, filed Jun. 12, 2012.

**[0012]** U.S. Provisional Patent Application Ser. No. 61/595,326, filed Feb. 6, 2012.

**[0013]** U.S. Provisional Patent Application Ser. No. 61/640,420, filed Apr. 30, 2012.

**[0014]** U.S. patent application Ser. No. 13/864,694, filed Apr. 17, 2013.

**[0015]** U.S. Provisional Patent Application Ser. No. 61/658,603, filed Jun. 12, 2012.

### SUMMARY

**[0016]** Electronic systems for monitoring and controlling internal combustion engine filtration systems are disclosed. A micro-controller processing unit reads inputs from various electronic sensors and devices associated with various filtration systems of the internal combustion engine, and engine parameters from the ECM to make critical decisions like monitoring filter element (e.g., a cartridge element, a spin-on filter, etc.) condition, predicting remaining filter element service, calculating effect on engine performance, and providing service and diagnostic indications. The micro-controller processing unit is capable of monitoring multiple filtration systems associated with the internal combustion engine (e.g., fuel filtration systems, hydraulic fluid filtration systems, air filtration systems, lubricant filtration systems, etc.) at the same time. The monitored filtration systems may be mounted inside or outside of the engine compartment. The micro-controller processing unit provides service indications relating to given filtration systems based on installed sensors (e.g., pressure drop sensors, mass air flow (“MAF”) sensors, virtual sensors, etc.) and/or service indicating algorithms (e.g., algorithms that calculate a total amount of fluid volume filtered). The micro-controller processing unit also can determine whether a genuine filter element is being used by the internal combustion engine (i.e., whether a service technician installed a genuine filter element or an inappropriate knock-off filter element) through genuine filter recognition techniques using digital encryption and/or analog methods. Further, the micro-controller processing unit includes a variety of output capabilities (e.g., smart-phone applications, service technician tools, original equipment manufacturer telematics, dashboard indicator lights, dashboard displayed fault codes, etc.). The micro-controller processing unit utilizes algorithms and programs for retrieving, managing, interpreting and predicting filter information.

**[0017]** A unique integrated system is disclosed with various electronic interfaces including analog and digital input/output connections between filtration devices/sensors and the controller unit, computer area network (“CAN”) connection between the ECM and the controller unit, wireless (e.g., Bluetooth®, WiFi®, ZigBee®, etc.) connection between the micro-controller and a smart-phone application software, liquid crystal display (“LCD”) monitors, universal serial bus (“USB”) ports, and/or cellular data network connection interface between the smart-phone device and a back-end server.

**[0018]** A first embodiment relates to a filter monitoring system for an internal combustion engine. The filter monitoring system includes a filter control module (“FCM”) having a first input that receives at least one filtration parameter from an engine filtration device system for filtering a fluid in the internal combustion engine. The filter monitoring system further includes a second input that receives at least one engine parameter from an ECM, the ECM controlling operations of the internal combustion engine. The FCM outputs a command signal via a first output based upon the filtration parameter and engine parameter.

**[0019]** Another embodiment relates to a filter monitoring system (“FMS”) for monitoring a plurality of separate filtration systems of an internal combustion engine. The system includes a first sensor associated with a first filtration system of the internal combustion engine, and a second sensor associated with a second filtration system of the internal combustion engine. The system further includes a FMS module. The FMS module includes a memory, at least one communication interface, an output coupled to a user output, and a processor. The communication interface provides data communication between the FMS module and an ECM of the internal combustion engine, the first sensor, and the second sensor. The processor is configured to receive input signals from the first sensor and the second sensor, and to provide service indicators for the first filtration system and the second filtration system via the user output.

**[0020]** A further embodiment relates to a monitoring system for monitoring a plurality of separate filtration systems and at least one fluid system of an internal combustion engine. The monitoring system includes a first sensor associated with a first filtration system of the internal combustion engine, a second sensor associated with a second filtration system of the internal combustion engine, and a third sensor configured to monitor a characteristic of a fluid associated with a fluid system of the internal combustion engine. The system further includes a monitoring module. The monitoring module includes a memory, at least one communication interface, an output coupled to a user output, and a processor. The communication interface provides data communication between the FMS module and an ECM of the internal combustion engine, the first sensor, the second sensor, and the third sensor. The processor is configured to receive input signals from the first sensor, the second sensor, and the third sensor, and to provide service indicators for the first filtration system, the second filtration system, and the fluid system via the user output.

**[0021]** These and other features, together with the organization and manner of operation thereof, will become apparent from the following detailed description when taken in conjunction with the accompanying drawings, wherein like elements have like numerals throughout the several drawings described below.

#### BRIEF DESCRIPTION OF THE FIGURES

**[0022]** FIG. 1 shows a block diagram of a FMS according to an exemplary embodiment.

**[0023]** FIG. 2A shows a perspective view of the FMS of FIG. 1.

**[0024]** FIGS. 2B and 2C show views of the FMS of FIG. 1 connected to a wiring harness of an internal combustion engine.

**[0025]** FIGS. 2D and 2E show block diagrams of the FMS of FIG. 1 arranged to perform genuine filter recognition according to exemplary embodiments.

**[0026]** FIG. 3 shows a block diagram of various software modules and control algorithms stored in a memory of the FMS of FIG. 1.

**[0027]** FIG. 4A and FIG. 4B show a block diagram of the FMS of FIG. 1 transmitting information to external devices.

**[0028]** FIG. 5 shows an information output table according to an exemplary embodiment.

**[0029]** FIG. 6 shows a schematic diagram of the FMS of FIG. 1 communicating with a smartphone.

**[0030]** FIG. 7A-1 and FIG. 7A-2 show an electrical diagram of the FMS of FIG. 1 outputting data to a dashboard mounted display.

**[0031]** FIG. 7B shows a schematic diagram of the FMS of FIG. 1 outputting data to a dashboard mounted display.

#### DETAILED DESCRIPTION

**[0032]** Referring generally to the figures, a filter monitoring system (“FMS”) is disclosed. The FMS includes (i) several input channels, (ii) a central processing and control unit, and (iii) several output channels. The input and output channels can be analog, digital, and/or based on SAE J1939 CAN protocols. The processing and control unit comprises electronic chips, micro-processors, memory modules, wireless communication modules and other integrated electronic components. The FMS receives input from multiple sources, such as filtration systems and the internal combustion engine’s ECM. Based on the multiple inputs, the FMS determines optimal service time such that multiple filtration systems can be serviced at the same time instead of in multiple single purpose services. Such synchronization of services provides added convenience for the operators and reduces the downtime of the internal combustion engine, and therefore the downtime of the vehicle or equipment powered by the internal combustion engine. Further, additional information about the overall operation of the internal combustion engine can be gleaned from the multiple system analysis that may not be available from a traditional single system monitoring system. For example, if the FMS determines that lubrication oil is deteriorating, the FMS may determine other issues with other systems that are lubricated by the oil (e.g., fuel pumps), which may decrease the functionality of the other systems (e.g., reduce fuel pump efficiency, reduced life of lubrication oil wetted components, etc.). The FMS is capable of sending output to the user through various modes, for example, through a Bluetooth or Wi-Fi network to a smart-phone, through a wired connection to an LCD display screen on the vehicle dashboard, through a wireless communication link to existing OEM telematics systems, through a USB connection to a laptop computer, etc.

**[0033]** Referring to FIG. 1, a block diagram of a FMS module 100 is shown according to an exemplary embodiment. The FMS module 100 includes a plurality of inputs 102, a processing and control unit 104, and at least one output 106. The plurality of inputs 102 are provided to the processing and control unit 104. In some arrangements, the processing and control unit 104 is connected to the inputs via a communication bus. As described in further detail below, the processing and control unit 104 determines the status and optimal service times for the various filtration systems of the internal combustion system based on the inputs 102. The



processing and control unit **104** communicates the filtration systems' statuses and optimal service times to the internal combustion engine operator (e.g., a driver, an equipment operator, a service technician, an equipment owner, a central dispatch facility, etc.) via the at least one output **106**.

**[0034]** The plurality of inputs **102** includes a power supply input **108**, a recognition signal input **110**, analog sensor inputs **112**, and an ECM input **114**. The power supply input **108** provides power to the processing and control unit **104**. The power supply input may be a power source independent of the internal combustion engine (e.g., a separate battery) or power provided from the internal combustion engine (e.g., via an alternator, the internal combustion engine's batter). The recognition signal input **110** provides an indication of whether the various filtration systems are using genuine filter elements. The various filtration systems may include a fuel-water separator ("FWS"), a fuel filter ("FF"), a lubricant filter ("LF"), an air filter, hydraulic fluid filters, crankcase ventilation filters or separators, coolant filters, and the like. It should also be understood that, as used herein, "separate" filtration systems may also include individual subsystems of a broader filtration system. By way of example, in a crankcase ventilation system, the portion of the system surrounding a crankcase ventilation impactor may be considered one "system," while a portion of the system crankcase ventilation coalescer (downstream of the crankcase ventilation impactor) may be another "system."

**[0035]** In some arrangements, the recognition signal input **110** utilizes a single digital connection (e.g., using 1-Wire® digital protocol) to the processing and control unit **104**. The analog inputs **112** may be sensor inputs, such as pressure differential ("dP") sensor inputs, associated with the various filtration systems of the internal combustion engine. The dP sensor may include a first pressure sensor positioned on a first side of the filter element and a second pressure sensor positioned on a second side of the filter element such that the pressure drop across the filter element can be calculated. The ECM input **114** provides other engine parameters to the processing and control unit **104**, such as MAF sensor output, engine speed, filter flow rates, temperature-barometric atmospheric pressure sensor ("TBAP") output, water-in-fuel ("WIF") sensor output, etc. The ECM input **114** may be provided via a J1939 CAN protocol.

**[0036]** The processing and control unit **104** includes a microcontroller **116** (referenced as "uC" in FIG. 1). The microcontroller **116** controls the various functions of the FMS module **100**. The processing and control unit **104** includes a flash storage **118**. The flash storage **118** stores diagnostic information (e.g., as gathered from the plurality of inputs **102**). The processing and control unit **104** further includes a memory **120**. The memory **120** stores programming modules that, when executed by the microcontroller **116**, control the operation of the FMS module **100**. The memory **120** may also include reprogrammable variables used in algorithms that calculate expected filter life. In some arrangements, the flash storage **118** and the memory **120** are embodied in a single memory device. The processing and control unit **104** also includes a communication module **122**. The communication module **122** may be a wireless communication module (e.g., Bluetooth®, WiFi, ZigBee, cellular data transceiver, etc.) or a wired communication module (e.g., USB®, Ethernet, etc.). In such arrangements, the wireless communication module is designed to communicate with external devices in the presence of wireless inter-

ference or noise caused by the internal combustion engine. In some arrangements, the processing and control unit **104** is embodied as a system-on-chip controller (i.e., the microcontroller **116**, the flash storage **118**, the memory **120**, and the communication module **122** are embodied on a single chip).

**[0037]** The processing and control unit **104** provides output to the output devices **106**. The output devices **106** may include a dashboard display, a personal computer ("PC"), and/or wireless devices (e.g., smartphones, tablet computers, laptop computers, personal digital assistants, etc.). The processing and control unit **104** transmits filtration system statuses and service indications to the output devices **106**. The output devices **106** receive the statuses and service indications via a wired connection to the microcontroller **116** (e.g., Ethernet) or via the communication module **122**.

**[0038]** Referring to FIG. 2A, a perspective view of a FMS module **100** embodying FMS module **100** is shown according to an exemplary embodiment. The FMS module **100** is enclosed in a housing **202**. A wiring harness **204** of the FMS module **100** is exposed. The wiring harness **204** connects the FMS module to the various inputs and outputs of the FMS module **100** (as described above with respect to FIG. 1). As shown in FIG. 2A, the FMS module **100** is based on the packaging method employed by the Cummins Energy Manager ("CEM") module disclosed in the incorporated U.S. patent application Ser. No. 13/412,280, filed Mar. 5, 2012, published Oct. 4, 2012 as U.S. Patent Publication No. US 2012/0253595A1. Although the housing **202** the FMS module **100** has a similar appearance to a CEM module, the layout of the components (e.g., as described above with respect to processing and control unit **104** of FIG. 1) and the wiring harness **202** (e.g., pin configurations), and the software modules are customized for functioning as a FMS module.

**[0039]** Possible functions performed by FMS module **100** include, but are not limited to: electronic genuine filter detection, WIF indication (e.g., based on feedback from a WIF sensor), automatic water drain control (e.g., via an automatic drain in the fuel filtration system), filter service indication (e.g., via a determination of a total amount of fluid filtered by a particular filtration system, a detected pressure drop across a filter element, the output of a service-life algorithm, etc.), fixed interval based filter service indication, oil quality monitoring and oil drain interval indication, control and release of chemical additives, fuel quality sensing and indication, leak or bypass condition detection and indication, data connection to the ECM via J-1939, and data output communication with the various output devices **106** (e.g., LCD monitors, smart phone applications, OEM telematics system, technician computers, etc.).

**[0040]** As shown in FIGS. 2B and 2C, the FMS module **100** connects to the wiring of an internal combustion engine. The FMS module **100** connects to a wiring harness **206** of the internal combustion engine. The wiring harness **206** includes a connector **208** that receives the FMS module **100**. The housing **202** of the FMS module **100** may form a snap-fit connection with the connector **208**. Through the wiring harness **206**, the FMS module **100** the various inputs **102** and may communicate with at least a portion of the outputs **106**. In some arrangements, the FMS module **100** receives operating power via the wiring harness **206** (e.g., from the ECM, directly from internal combustion engine

battery, etc.). In other arrangements, the FMS module 100 includes a built-in power source independent of the internal combustion engine.

[0041] The FMS 100 runs various algorithms to perform different filter monitoring functions. Referring to FIG. 3, a block diagram of the various software modules and control algorithms stored in flash module 118 and/or memory 120 are shown. Each software module and algorithm block that the FMS module 100 can run are shown.

[0042] In some arrangements, the FMS 100 also is part of a broader fluid monitoring system. In such arrangements, the FMS 100 also receives sensor feedback from fluid sensors associated with various fluids used by the internal combustion system. The fluid sensors may be independent of the filtration systems of the internal combustion engine. For example, the fluid sensors may measure characteristics of the fuel supplied by the fuel system, the lubricant circulated by the lubrication system, the hydraulic fluid used by the hydraulic system, etc. The fluid sensors may be positioned near or within fluid pumps (e.g., a fuel pump, a lubricant pump, a hydraulic fluid pump, etc.) in plumbing that supplies the fluids to the various components of the internal combustion engine, in the engine block, and other locations within and around the internal combustion engine that receive fluid filtered by the various filtration systems of the internal combustion engine. The fluid sensors may include temperature sensors, pressure sensors, viscosity sensors, chemical sensors (e.g., to detect chemical additives within the fluid, to detect contaminants within the fluid, etc.), and the like.

[0043] The information from the fluid sensors can be used by the FMS 100 to determine service intervals for the fluids. For example, the fluid sensors of a lubricant system may provide a better indication of thermal breakdown of the lubricant than can be gleaned from the sensors located at the lubricant filtration system. Additionally, the information received from the fluid sensors can be used in the various filter system service calculations performed by the FMS 100. For example, an information relating to a type of fuel flowing through a fuel filtration system may affect the expected life span of the fuel filter element. Information received from the fluid sensors, along with calculated information about the various fluid systems (e.g., fluid replacement warnings, expected remaining life of the engine fluids, etc.) can be output to the user or technician in a similar manner as described below with respect to the filter system information provided to the users and technicians. The information from the fluid sensors, in conjunction with the information from the filtration system sensors, can, for example be used to determine the optimal time to service the engine filters and fluid(s), as well as provide this information to users and/or technicians.

[0044] In further arrangements, the FMS 100 can also receive sensor information from other systems of the internal combustion engine or the equipment powered by the internal combustion system. For example, if the internal combustion engine powers a vehicle, the FMS 100 may receive sensor input from a tire pressure measurement system, exhaust sensors, ambient temperatures, vehicle speed sensor, and the like. This additional information may be used to assist with other calculations performed by the FMS 100 (e.g., filter life calculations, fluid life calculations, etc.).

[0045] Certain functions of the electronic FMS 100 are described in further detail below.

#### Electronic Genuine Filter Recognition

[0046] Various engine filter systems can be connected to the FMS module 100 via wired or wireless connections. The FMS module 100 can recognize if a genuine filter element is installed in any particular filtration system of the filtration systems of the internal combustion engine. The use of genuine filter elements (e.g., as replaced during a filtration system service operation) helps to protect the filtration system's integrity, and thus the internal combustion engine's integrity. Accordingly, the use of genuine filter elements provides the best and most reliable performance of the internal combustion engine. The FMS performs genuine filter recognition in various manners for different filter systems. For example, fuel-water separator products that have analog WIF sensors can be recognized as genuine through analog filter recognition features (e.g., as described in the incorporated U.S. patent application Ser. No. 13/864,694, filed Apr. 17, 2013), or fuel-water separators that have digital WIF sensors (e.g., as described in the incorporated U.S. Provisional Patent Application Ser. No. 61/810,946, filed Apr. 11, 2013) can be connected to the FMS module 100 to recognize if a genuine fuel-water separator is installed. In another example, the FMS module 100 could be connected to a fuel-filter separator with a digital recognition feature installed on a bracket. In a third example, a fuel/lube module with a digital recognition feature capable of recognizing a genuine filter cartridge element may be connected to the FMS module 100.

[0047] Various filter element recognition techniques may be used by the FMS 100 in determining whether an installed filter element is genuine. Referring to FIG. 2D, a block diagram of the FMS 100 arranged to perform genuine filter recognition is shown according to an exemplary embodiment. The FMS 100 is connected to a lubricant filtration system 210, a first stage fuel filtration system 212, a second stage fuel filtration system 214, and an air filtration system 216. Each of the filter elements for the lubricant filtration system 210, the first and second stage fuel filtration systems 212 and 214, and the air filtration system 218 includes a 1-Wire chip embedded into the filter element. The 1-Wire chip includes filter element identifying information that is sent via a wired connection to the FMS 100. The FMS 100 can determine whether the installed filter elements are genuine or not genuine based on the identifying information (or lack thereof) that is sent from the 1-Wire chips to the FMS 100. In other arrangements, a different type of identifying circuit (e.g., a resistor based circuit, a non-1-Wire based circuit, etc.) is embedded into each filter element that provides identifying information to the FMS 100.

[0048] Referring to FIG. 2E, a block diagram of the FMS 100 arranged to perform genuine filter recognition is shown according to another exemplary embodiment. The arrangement of FIG. 2E is similar to that of FIG. 2D. However, in FIG. 2E, each filter element of the various filtration systems are fitted with a radio frequency identification ("RFID") chip. The RFID chips include identifying information, such as a filter element serial number or code. The RFID chips may be passive RFID chips (e.g., wirelessly powered by an RFID reader) or active RFID chips (e.g., having an independent power source). In the embodiment depicted in FIG. 2E, each filter housing that receives the filter elements

includes an RFID reader that provides RFID chip information to the FMS 100 via a wired or wireless connection. (In alternative implementations, the RFID reader may be positioned within or on the filter head, the filter module, or another nearby location.) Accordingly, when a filter element having an RFID chip in a designated position (e.g., in a position such that the RFID chip is positioned near the RFID reader when the filter element is installed), the identifying information is read by the RFID reader and transmitted to the FMS 100. Based on the identifying information, the FMS 100 can determine whether the installed filter element is genuine or not genuine. In other arrangements, other wireless identifier transmission systems are used (e.g., near field communication, Bluetooth, Bluetooth Low Energy, WiFi, etc.),

**[0049]** The FMS module 100 can have built-in programming and calibration to recognize the genuine filters and to identify non-approved filter elements installed in any of the filtration systems. The built-in programming and calibration may be in the form of stored rules for recognizing serial numbers, part numbers, or any other encryption method (e.g., stored in flash module 118 or memory 120). In an alternative arrangement, the built-in programming and calibration may be in the form of stored rules for recognizing the presence and form of electrical output from sensor associated with genuine filter elements, or the absence thereof.

**[0050]** In some arrangements, the FMS 100 has the capability to turn-on or turn-off certain features and indications based on the status of genuine filter detection. For example, the FMS module 100 may send genuine or non-genuine filter information to the ECM such that the ECM can take corresponding actions (e.g., derating the engine, placing the engine in a limp mode, etc.), or such that the ECM can alert the user/operator with a warning (e.g., a dashboard indicator). When an internal combustion engine is placed into limp mode, the engine is operating in a mode with marginal functionality (e.g., enough engine output to allow the vehicle or equipment to be moved to a service facility, but not much functionality beyond that). The FMS module 100 may also limit other features of the FMS module 100 upon detection of an installed non-authorized replacement filter element. For example, the FMS module 100 may decide to not indicate service life based on a dP sensor feedback signal if a genuine filter is not detected (i.e., such that the user cannot take full advantage of the features of the FMS module 100). In another example, the FMS module 100 may convey information about an installed non-genuine filter to the ECM, in which case, the ECM may limit the engine power, de-rate the engine, and the like in order to protect the engine from catastrophic failures.

#### WIF Indication and/or Automatic Water Drain

**[0051]** In some internal combustion engines, the WIF sensor of a fuel-water separator is connected to the engine ECM. The FMS module 100 receives input from the ECM (e.g., via the ECM input 114) and is capable of taking the input from the analog or digital WIF sensor via the ECM. Based on the input from the WIF sensor, the FMS module 100 can provide water drain indication directly to the user or operator of the internal combustion engine. The water drain indication is triggered when the WIF sensor detects a threshold amount of water in the fuel-water separator housing. In some arrangements, the FMS module 100 is capable of warning the user or operator of an imminent fuel-system failure if the FMS module 100 detects that water has not

been drained for a long period of time, thus saving the user or operator from expensive engine system break-downs.

**[0052]** In arrangements where an automatic water detection and/or water drain device (e.g., see the incorporated U.S. Pat. No. 6,207,045 or the incorporated U.S. patent application Ser. No. 12/860,499, filed Aug. 20, 2010, now U.S. Pat. No. 8,409,446, issued Apr. 2, 2013) is installed and connected to the FMS module 100, the FMS module 100 can trigger the initiation of a water drain event by sending activation signals to a controller component (e.g., such as a solenoid valve of the automatic water drain) installed on the auto-drain device.

#### Service Indication Via Input from dP Sensors

**[0053]** FMS module 100 is capable of connecting to dP sensors installed on existing filtration systems. The FMS module 100 collects restriction information from the dP sensors and uses the restriction information to gauge the plugging condition of the filter system. Additionally, the FMS module 100 is also connected to the ECM through the J1939 datalink and draws important engine parameters from the ECM, which the FMS module 100 uses to calculate the fluid flow-rate through the filter system. This calculation is done individually for each of the filter systems (example lube filter, fuel filter, fuel-water separator, air filter, etc.). Based on the outcome of the calculation, the FMS module 100 can send an indication to a user or operator via the outputs 106 of the internal combustion engine indicating a filter life (e.g., a percentage of filter life remaining, a number of miles of filter life remaining, etc.) and a replace filter indication.

#### Service Indication Based on Fixed Service Interval

**[0054]** In cases where the dP sensors are not available to the FMS module 100 (e.g., the dP sensors are not connected or are faulty), the FMS module 100 is capable of switching to a fixed service interval mode to protect the integrity of the engine. Accordingly, the FMS module 100 will still provide indication for service life when threshold miles/hours of filter are used.

#### Oil Quality Indication and Service Predictions

**[0055]** The FMS module 100 is capable of connecting to an oil quality sensor installed in the lubrication system of the engine. An exemplary sensor is described in U.S. Provisional Patent Application No. 61/838,962, filed Jun. 25, 2013, the entire disclosure of which is incorporated herein by reference. With inputs from the oil quality sensor (e.g., as described above with respect to the fluid sensors), and with other engine parameters received from ECM via the J1939 datalink, the FMS module 100 can calculate a condition of oil (e.g., an amount of life left in the oil). The FMS module 100 can indicate usable service life of the oil to the user or operator of the engine via the outputs 106. The FMS module 100 may also provide indication for oil drain interval.

#### Control of Chemical Additives and Release of Additives

**[0056]** Some internal combustion engines include a chemically active lube filter ("CALF") (e.g., as described in the incorporated U.S. patent application Ser. No. 13/827,992, filed Mar. 14, 2013 and U.S. Provisional Patent Application Ser. Nos. 61/658,603, filed Jun. 12, 2012 and 61/595,326, filed Feb. 6, 2012). In arrangements where a CALF is present on the engine, the FMS module 100 can calculate a

quality of oil, and electronically control the release of a particular amount of chemical additives to the oil from a chemical reservoir to improve the condition of the lubricating oil. The electronic control and release of additives in the oil system, based on feedback from the oil quality sensing function of the FMS module 100, is an efficient method of controlling and extending oil quality as compared to chemical release based on a calculated pressure differential.

#### Fuel Quality Sensing and Indication

[0057] Various other sensors for fuel quality sensing (e.g., a sulfur sensor, a water content sensor, etc.) can be connected to the FMS module 100. The fuel quality sensors allow the FMS module 100 to determine fuel quality and to provide an indication of the fuel quality to the user or operator via the outputs 106. The signals from the fuel quality sensors can also be provided to the ECM through the J1939 datalink from the FMS module 100 such that the ECM can make decisions for de-rating, shutting down or operating in a safe-mode when poor quality fuel is sensed, thereby protecting from catastrophic engine and fuel-system failures. Alternatively or additionally, the fuel quality sensor may be a fuel type sensor (e.g., a sensor that determines whether the internal combustion engine is using ultra-low sulfur diesel fuel or biodiesel).

#### Data Output Functions

[0058] The FMS module 100 has the capability to transmit processed data to external devices by various means. Referring to FIGS. 4A and 4B, a block diagram of the FMS module 100 transmitting information to external devices via four exemplary methods is shown according to an exemplary embodiment. The four different methods of data output include output to a smartphone application 402 (e.g., via Bluetooth or Wi-Fi; as described in additional detail below with respect to FIG. 6), output to a directly to an engine operator via a dashboard mounted display 404 (e.g., as described in further detail below with respect to FIGS. 7A-1, 7A-2 and 7B), to an OEM telematics communication link 406, and output to a service technician tool 408 (e.g., a computer). The FMS module 100 may transmit processed data directly to these devices or may do so via an intermediary device, such as the ECM. For example, the FMS module 100 may transmit data to the ECM, which transmits a fault code to the dashboard mounted display 404 or other device.

[0059] The FMS module 100 may output processed information to any individual or combination of these output devices by various methods. One example method is via the use of 'Output Tables'. The FMS module 100 may process all information and build a table of parameters with their respective values for each monitored filter system, which can then be transmitted in part or in entirety to the output device reading from the FMS module 100. Referring to FIG. 5, an exemplary FMS output table 400 is shown according to an exemplary embodiment. The receiving device (e.g., a service technician's computer, an operator's smartphone, etc.) may need to first need to establish a secure connection with the FMS module 100 via a pre-determined authorization code method of hand-shaking, before the output table can be transmitted to the device (e.g., pair the receiving device with the FMS module 100 via the Bluetooth pairing process). Although shown as being able to connect to four

different types of devices, the FMS module 100 is capable of connecting to other types of output devices that can establish a communication session with the FMS module 100.

[0060] Referring to FIG. 6, the FMS module 100 can communicate wirelessly with output devices, such as a user's smartphone 602. The smartphone 602 is running a smartphone application 402 that enables the communication between the smartphone 602 and the FMS module 100. Through the smartphone application 402, the FMS module 100 can communicate information relating to the various statuses of the monitored filtration systems of the internal combustion engine. The information may include information relating to a current status (e.g., operational, errors), upcoming service information (e.g., time to next service, miles to next service, etc.), filter element identification information, and other information on a filtration system-by-system basis. The user of the smartphone 602 can interact with the smartphone application 402 (e.g., through interaction with a graphical user interface of the smartphone application 402) to retrieve real-time or near real-time data from the FMS module 100. As discussed above, retrieving the information from the FMS module 100 may require that the smartphone 602 go through a pairing process with the FMS module 100.

[0061] Referring to FIGS. 7A-1 AND 7A-2, an electrical diagram of the FMS module 100 outputting data to a dashboard mounted display 404 is shown according to an exemplary embodiment. FIG. 7B shows the dashboard mounted display 404 connected to the FMS module 100. Through the dashboard mounted display, a user or operator of the internal combustion engine (e.g., a driver of a vehicle powered by the internal combustion engine) can review information relating to the various statuses of the monitored filtration systems of the internal combustion engine. The information may include information relating to a current status (e.g., operational, errors), upcoming service information (e.g., time to next service, miles to next service, etc.), filter element identification information, and other information on a filtration system-by-system basis. The user or operator can interact with a graphical user interface of the dashboard mounted display 404 in a similar manner as described above with respect to the smartphone application 402.

[0062] In the present disclosure, certain terms have been used for brevity, clearness and understanding. No unnecessary limitations are to be implied therefrom beyond the requirement of the prior art because such terms are used for descriptive purposes only and are intended to be broadly construed. The different systems and methods described herein may be used alone or in combination with other systems and devices. Various equivalents, alternatives and modifications are possible within the scope of the appended claims. Each limitation in the appended claims is intended to invoke interpretation under 35 U.S.C. § 112, sixth paragraph only if the terms "means for" or "step for" are explicitly recited in the respective limitation.

[0063] It should be noted that the term "exemplary" as used herein to describe various embodiments is intended to indicate that such embodiments are possible examples, representations, and/or illustrations of possible embodiments (and such term is not intended to connote that such embodiments are necessarily extraordinary or superlative examples).

**[0064]** Any references herein to the positions of elements are merely used to describe the orientation of various elements in the FIGURES. It should be noted that the orientation of various elements may differ according to other exemplary embodiments, and that such variations are intended to be encompassed by the present disclosure.

**[0065]** It is important to note that the construction and arrangement of the various exemplary embodiments are illustrative only. Although only a few embodiments have been described in detail in this disclosure, those skilled in the art who review this disclosure will readily appreciate that many modifications are possible (e.g., variations in sizes, dimensions, structures, shapes and proportions of the various elements, values of parameters, mounting arrangements, use of materials, colors, orientations, etc.) without materially departing from the novel teachings and advantages of the subject matter described herein. For example, elements shown as integrally formed may be constructed of multiple parts or elements, the position of elements may be reversed or otherwise varied, and the nature or number of discrete elements or positions may be altered or varied. The order or sequence of any process or method steps may be varied or re-sequenced according to alternative embodiments. Other substitutions, modifications, changes and omissions may also be made in the design, operating conditions and arrangement of the various exemplary embodiments without departing from the scope of the present invention.

What is claimed is:

1. A system, comprising:
  - a plurality of filtration systems, each of the plurality of filtration systems comprising:
    - a housing, and
    - a filter element associated with the housing;
  - a plurality of wireless communication tags associated with the plurality of filtration systems;
  - a plurality of antennas; and
  - a filter monitoring system (“FMS”) module in wired communication with the plurality of antennas, the FMS module configured to send data to and receive data from the plurality of wireless communication tags via the antennas.
2. The system of claim 1, wherein the plurality of filtration systems comprise at least one of a lubrication filtration system, an air filtration system, or a fuel filtration system.
3. The system of claim 1, wherein the FMS module includes a plurality input channels and a plurality of output

channels configured to communicate with the plurality of wireless communication tags.

4. The system of claim 3, wherein the plurality of input channels and the plurality of output channels are associated with different filtration systems of the plurality of filtration systems.

5. The system of claim 1, wherein each of the plurality of wireless communication tags comprises a radio frequency identification (“RFID”) chip.

6. The system of claim 5, wherein each of the plurality of antennas comprises an RFID antenna.

7. The system of claim 1, wherein the FMS module is configured to interpret signals received from the plurality of antennas.

8. The system of claim 7, wherein the signals are indicative of an event associated with the at least one of the plurality of filtration systems.

9. The system of claim 8, wherein the event comprises installation of at least one filter element into a corresponding filtration system of the plurality of filter systems.

10. The system of claim 1, wherein the FMS module comprises a memory configured to store operations for monitoring functions of the plurality of filtration systems.

11. The system of claim 1, further comprising at least one sensor associated with at least one of each of the plurality of filtration systems, the plurality of wireless communication tags, or the FMS module.

12. The system of claim 1, wherein the plurality of wireless communication tags are configured to store information associated with a corresponding filtration system of the plurality of filtration systems.

13. The system of claim 12, wherein the information comprises at least one of a filter element serial number or a code.

14. The system of claim 1, wherein the FMS module is configured to store information comprising at least one of serial numbers, part numbers, or encryption methods associated with the plurality of filtration systems.

15. The system of claim 1, wherein the FMS module is configured to communicate with a user device via a wired connection.

16. The system of claim 1, wherein the FMS module is configured to communicate with a user device via a wireless connection.

\* \* \* \* \*