



US005961440A

United States Patent [19]
Schweich, Jr. et al.

[11] **Patent Number:** **5,961,440**
[45] **Date of Patent:** ***Oct. 5, 1999**

[54] **HEART WALL TENSION REDUCTION APPARATUS AND METHOD**

FOREIGN PATENT DOCUMENTS

WO 98/03213 1/1998 WIPO .

[75] Inventors: **Cyril J. Schweich, Jr.**, St. Paul; **Todd J. Mortier**, Minneapolis, both of Minn.

OTHER PUBLICATIONS

[73] Assignee: **Myocor, Inc.**, St. Paul, Minn.

Alonso-Lej, M.D., "Adjustable Annuloplasty for Tricuspid Insufficiency", *The Annals of Thoracic Surgery*, vol. 46, No. 3, Sep. 1988, 2 pages.

[*] Notice: This patent is subject to a terminal disclaimer.

Kurlansky et al., "Adjustable Annuloplasty for Tricuspid Insufficiency", *Ann. Thorac Surg.*, 44:404-406, Oct. 1987.
Boyd et al., "Tricuspid Annuloplasty", *The Journal of Thoracic Cardiovascular Surgery*, vol. 68, No. 3, Sep. 1974, 8 pages.

[21] Appl. No.: **08/933,456**

M. Dickstein et al., "Heart Reduction Surgery: An Analysis of the Impact on Cardiac Function", *The Journal of Thoracic and Cardiovascular Surgery*, vol. 113, No. 6, Jun. 1997, 9 pages.

[22] Filed: **Sep. 18, 1997**

Related U.S. Application Data

[63] Continuation-in-part of application No. 08/778,277, Jan. 2, 1997.

[51] **Int. Cl.⁶** **A61F 1/00**

[52] **U.S. Cl.** **600/16; 600/37**

[58] **Field of Search** 600/16-18, 37; 601/11, 153; 623/3, 11; 128/897

P. McCarthy et al., "Early Results with Partial Left Ventriculectomy", From the Departments of Thoracic and Cardiovascular Surgery, Cardiology, and Transplant Center, Cleveland Clinic Foundation, Presented at the 77th Annual Meeting of the American Association of Thoracic Surgeons, May 1997, 33 pages.

[56] **References Cited**

U.S. PATENT DOCUMENTS

Re. 34,021	8/1992	Mueller et al.	604/51
4,192,293	3/1980	Asrican	128/1
4,409,974	10/1983	Freedland	128/92
4,536,893	8/1985	Parravicini	601/153
4,944,753	7/1990	Burgess et al.	623/16
4,997,431	3/1991	Isner et al.	606/15
5,106,386	4/1992	Isner et al.	606/15
5,131,905	7/1992	Grooters	600/16
5,169,381	12/1992	Snyders	600/16
5,192,314	3/1993	Daskalakis	623/3
5,250,049	10/1993	Michael	606/72
5,284,488	2/1994	Sideris	606/213
5,385,528	1/1995	Wilk	600/18
5,433,727	7/1995	Sideris	606/213
5,496,305	3/1996	Kittrell et al.	606/15
5,509,428	4/1996	Dunlop	128/898
5,533,958	7/1996	Wilk	600/18
5,702,343	12/1997	Alferness	600/37

A. Carpentier and J.C. Chachques, "Myocardial Substitution with a Stimulated Skeletal Muscle: First Successful Clinical Case", Letter to the Editor, p. 1267, Sep. 25, 1996.

C. David Ianuzzo et al., "Preservation of the Latissimus Dorsi Muscle During Cardiomyoplasty Surgery", *J. Card. Surg.*, 1996:11:99-108.

(List continued on next page.)

Primary Examiner—Jeffrey R. Jastrzab
Attorney, Agent, or Firm—Finnegan, Henderson, Farabow, Garrett, & Dunner, L.L.P.

[57] **ABSTRACT**

An apparatus for treatment of a failing heart by reducing the wall tension therein. In one embodiment, the apparatus includes a tension member for drawing at least two walls of a heart chamber toward each other. Methods for placing the apparatus on the heart are also provided.

20 Claims, 8 Drawing Sheets

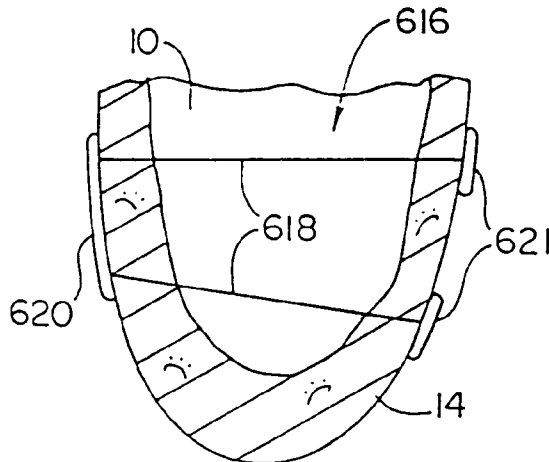

OTHER PUBLICATIONS

- C. David Ianuzzo et al., "Preconditioning of Skeletal Muscle: Application to Dynamic Cardiomyoplasty", Invited Commentary, *J. Card. Surg.*, 1996:109-110.
- J.C. Chachques et al., "Latissimus Dorsi Dynamic Cardiomyoplasty", *Ann. Thorac. Surg.*, 1989:47:600-604.
- L. Moreira et al., "Latissimus Dorsi Cardiomyoplasty in the Treatment of Patients with Dilated Cardiomyopathy", Supplement IV Circulation, Sep. 25, 1996, 7 pgs.
- C. Lucas et al., "Long-Term Follow-Up (12 to 35 Weeks) After Dynamic Cardiomyoplasty", *JACC*, vol. 22, No. 3, Sep. 1993: 758-67.
- R. Batista et al., "Partial Left Ventriculectomy to Improve Left Ventricular Function in End-Stage Heart Disease", *J. Card. Surg.*, 1996:11:96-98.
- "Congestive Heart Failure in the United States: A New Epidemic" Data Fact Sheet, National Heart, Lung, and Blood Institute, National Institutes of Health, Dec. 9, 1996, pp. 1-6.
- R. Kormos et al., "Experience with Univentricular Support in Mortally Ill Cardiac Transplant Candidates", *Ann. Thorac. Surg.*, 1990:49:261-71.
- R. Wampler et al., "Treatment of Cardiogenic Shock with the Hemopump Left Ventricular Assist Device", *Ann. Thorac. Surg.*, 1991:52:506-13.
- P. McCarthy et al., "Clinical Experience with the Novacor Ventricular Assist System", *J. Thorac Cardiovasc Surg.*, 1991:102:578-87.
- C. Burnett et al., "Improved Survival After Hemopump Insertion in Patients Experiencing Postcardiotomy Cardiogenic Shock During Cardiopulmonary Bypass", From the Section of Transplantation, Division of Cardiovascular Surgery, Texas Heart Institute and St. Luke's Episcopal Hospital, Houston, Texas, date even with or prior to Jan. 2, 1997, pp. 626-628.
- S. Phillips et al., "Hemopump Support for the Failing Heart", From the Department of Cardiovascular Medicine and Surgery, Mercy Hospital Medical Center, Des Moines, Iowa, date even with or prior to Jan. 2, 1997, pp. 629-631.
- G. Deeb et al., "Clinical Experience with the Nimbus Pump", From the University of Michigan Medical Center Section of Thoracic Surgery and Division of Cardiology, Ann Arbor, Michigan, date even with or prior to Jan. 2, 1997, pp. 632-636.
- G. Beamson et al., "Development of a Prototype Magnetically Suspended Rotor Ventricular Assist Device", *ASAIO Journal*, 1996, pp. 275-280.
- N. Sakakibara et al., "A Muscle Powered Cardiac Assist Device for Right Ventricular Support: Total Assist or Partial Assist?", *Trans Am Soc Artif Intern Organs*, vol. XXXVI, 1990, pp. 372-375.
- Medtronic, Inc. 1996 Annual Shareholders Report, 79 pages.
- ABIOMED, Inc. Annual Report 1996, 32 pages.
- Press Release dated Sep. 16, 1996, "ABIOMED Wins \$ 8.5 Million Federal Contract to Qualify its Artificial Heart for Human Trials", 5 pages.
- Press Release dated Sep. 26, 1996, "ABIOMED's Temporary Artificial Heart System Reaches 200 U.S. Medical Center Milestone", 1 page.
- Press Release dated May 17, 1996, "ABIOMED Receives FDA Approval to Expand Indications for Use of Cardiac Assist System", 1 page.
- Press Release dated Oct. 3, 1995, "ABIOMED Wins \$4.35 Million Contract from the National Heart, Lung and Blood Institutes to Develop Implantable Heart Booster", 1 page.
- Press Release dated Sep. 29, 1995, "ABIOMED Wins NIH Grant to Develop Calcification-Resistant Plastic Heart Valve", 1 page.
- Press Release dated Aug. 25, 1995, "ABIOMED Wins Research Grant from NIH to Develop Suturing Instrument for Abdominal Surgery", 1 page.
- Press Release dated Aug. 11, 1995, "ABIOMED Receives Grant from NIH to Develop Disposable Bearingless Centrifugal Blood Pump", 1 page.
- Press Release dated Jun. 9, 1995, "ABIOMED Receives Grant from National Institutes of Health to Develop a Laser Welding Technique for Tissue Repair", 1 page.
- Press Release dated Apr. 27, 1995, "ABIOMED Temporary Artificial Heart System Reaches 1,000 Patient Milestone; BVS-5000 in More Than 100 U.S. Medical Centers", 1 page.
- "Reversible Cardiomyopathy", *Thoratec's Heartbeat*, vol. 10.2, Aug. 1996, 4 pages.
- C. Tsai et al., "Surface Modifying Additives for Improved Device-Blood Compatibility", *ASAIO Journal*, 1994, pp. 619-624.
- D. Farrar et al., "A New Skeletal Muscle Linear-Pull Energy Converter as a Power Source for Prosthetic Support Devices", *The Journal of Heart & Lung Transplantation*, vol. 11, No. 5, Sep., 1992, pp. 341-349.
- Brochure entitled "Thoratec Ventricular Assist Device System—Because Heart Patients Come in All Sizes", date even with or prior to Jan. 2, 1997, 5 pages.
- Press Release dated Oct. 3, 1994, "Heartmate System Becomes First Implantable Cardiac-Assist Device to be Approved for Commercial Sale in the U.S.", 2 pages.
- E. Bocchi et al., "Clinical Outcome after Surgical Remodeling of Left Ventricle in Candidates to Heart Transplantation with Idiopathic Dilated Cardiomyopathy—Short Term Results", date even with or prior to Jan. 2, 1997, 1 page.
- Bach, M et al., "Early Improvement in Congestive Heart Failure after Correction of Secondary Mitral Regurgitation in End-Stage Cardiomyopathy", *American Heart Journal*, Jun. 1995, pp. 1165-1170.
- Schuler, G. et al., "Temporal Response of Left Ventricular Performance to Mitral Valve Surgery", vol. 59, No. 6, Jun. 1979, pp. 1218-1231.
- Huikuri, H., "Effect of Mitral Valve Replacement on Left Ventricular Function in Mitral Regurgitation", *Br Heart F*, vol. 49, 1983, pp. 328-333.
- Pitavry II., C. et al., "Long-Term Effects of Excision of the Mitral Apparatus on Global and Regional Ventricular Function in Humans", *JACC*, vol. 15, No. 3, Mar. 1, 1990, pp. 557-563.
- Bolling, S. et al., "Surgery for Acquired Heart Disease/Early Outcome of Mitral Valve Reconstruction in Patients with End-Stage Cardiomyopathy", *The Journal of Thoracic and Cardiovascular Surgery*, vol. 109, No. 4, Apr. 1995, pp. 676-683.
- Masahiro, O. et al., "Surgery for Acquired Heart Disease/ Effects of Preserving Mitral Apparatus on Ventricular Systolic Function in Mitral Valve Operations in Dogs", *The Journal of Thoracic and Cardiovascular Surgery*, vol. 106, No. 6, Dec. 1993, pp. 1138-1146.

Fig. 1

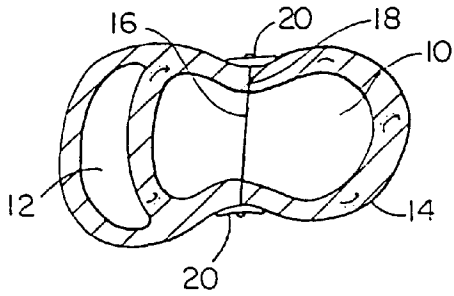

Fig. 2

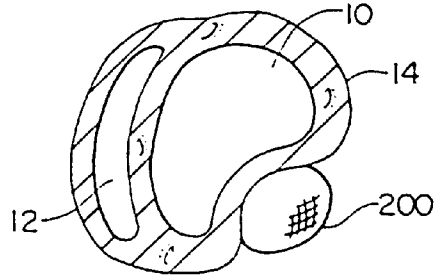

Fig. 3

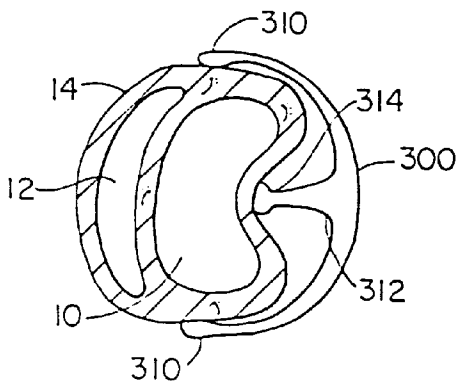

Fig. 4

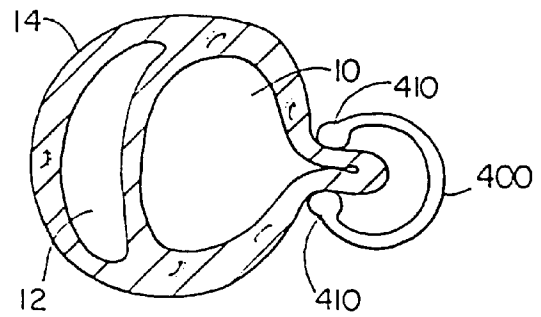

Fig. 5

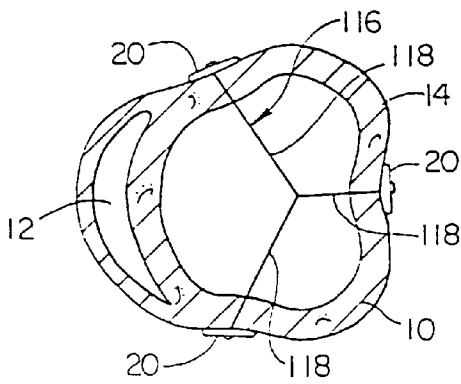

Fig. 6

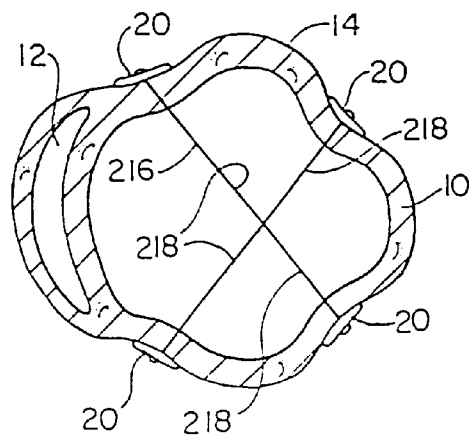

Fig. 8

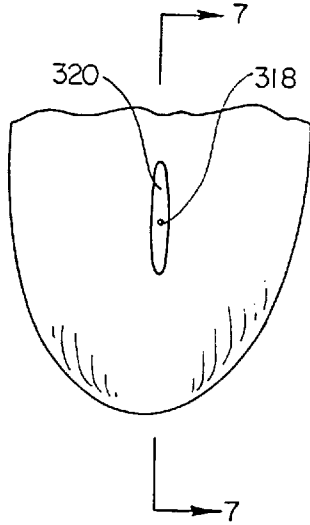

Fig. 7

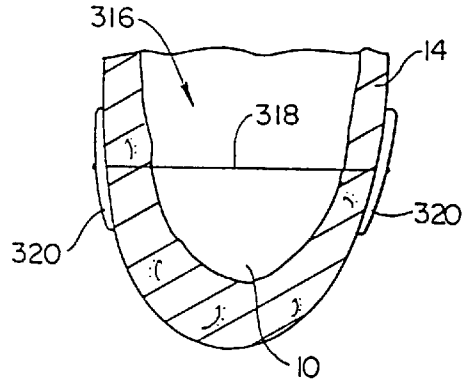

Fig. 9

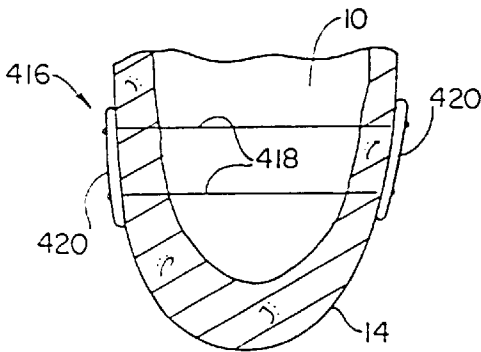

Fig. 10

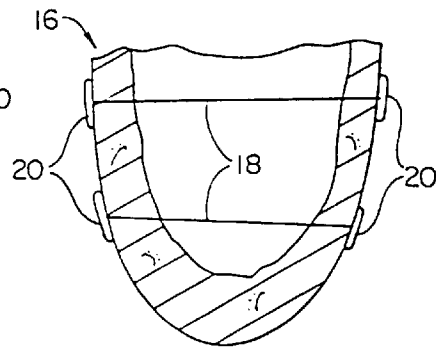

Fig. 11

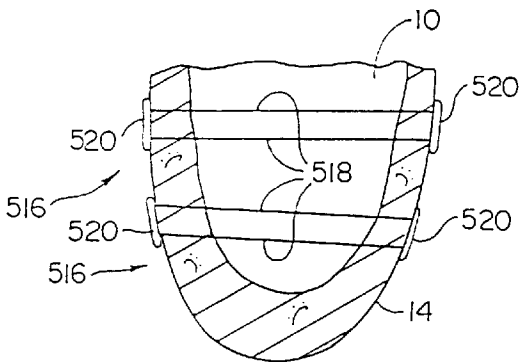

Fig. 12

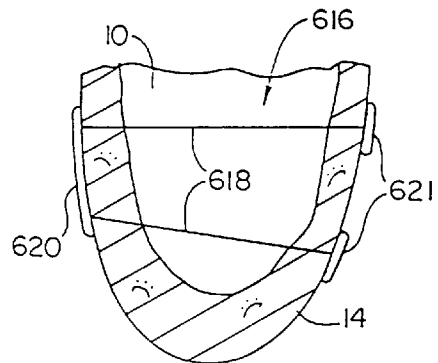

Fig.13

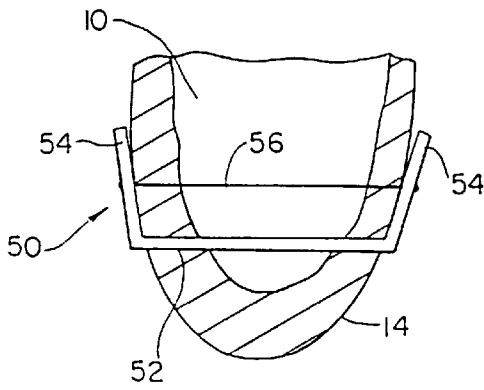

Fig.14

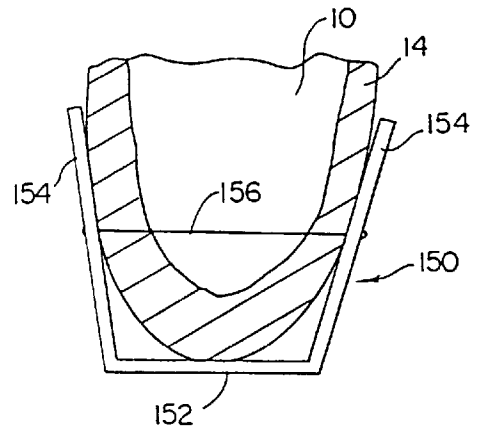

Fig.15

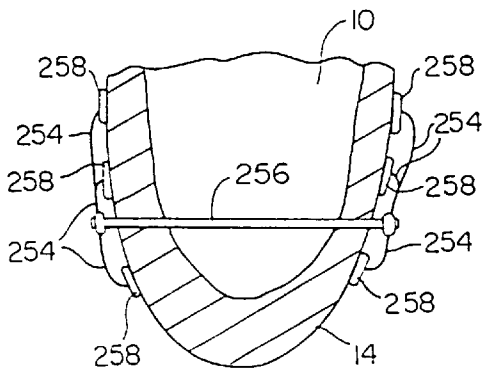

Fig.16

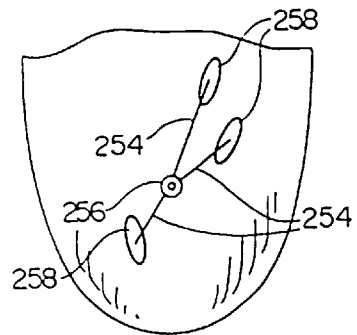

Fig. 17

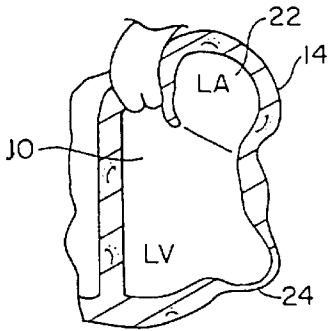

Fig. 18

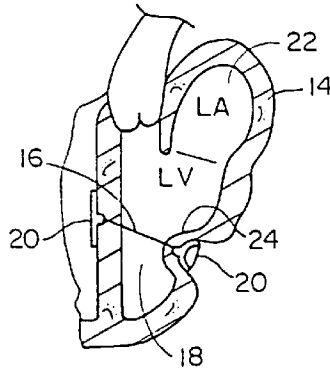

Fig. 19

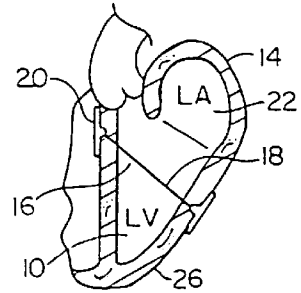

Fig. 22

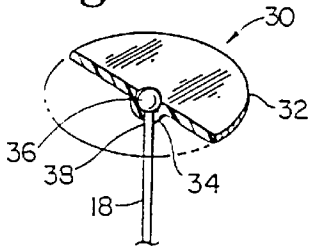

Fig. 23

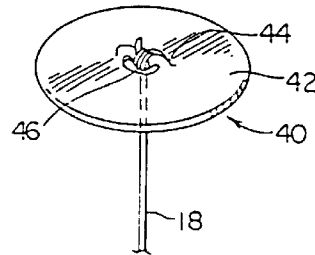

Fig. 20

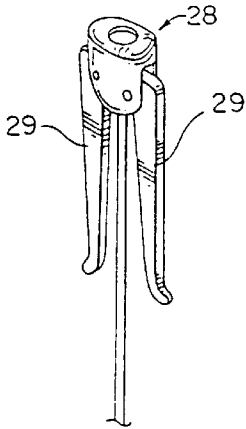

Fig. 21

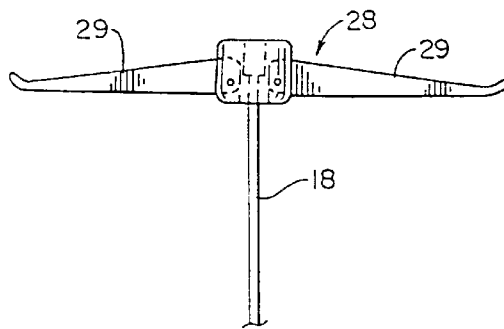

Fig. 24

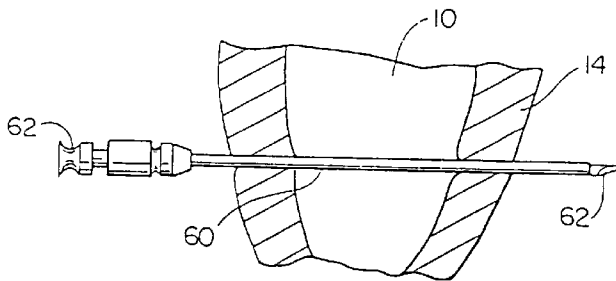

Fig. 25

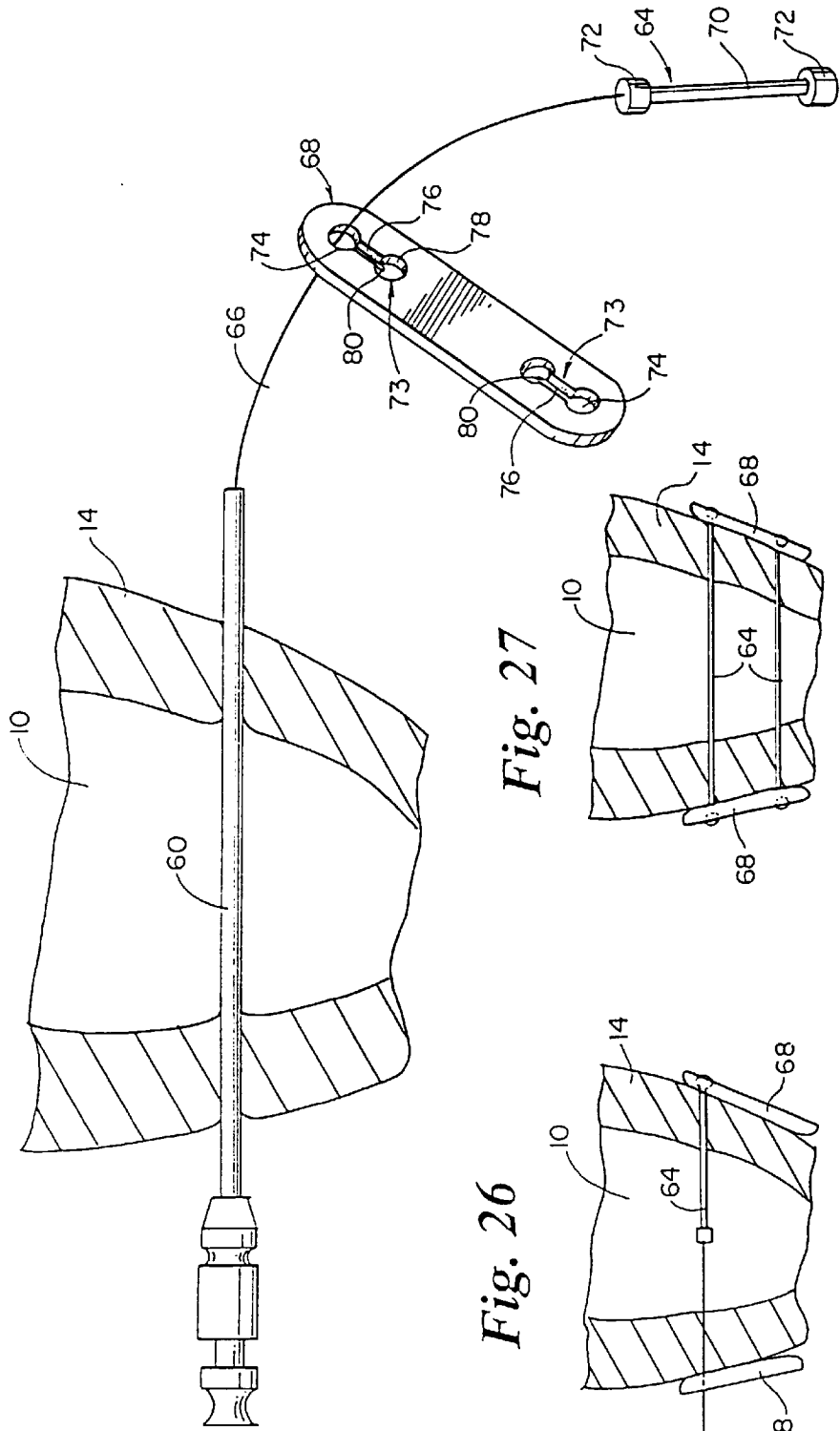

Fig. 26

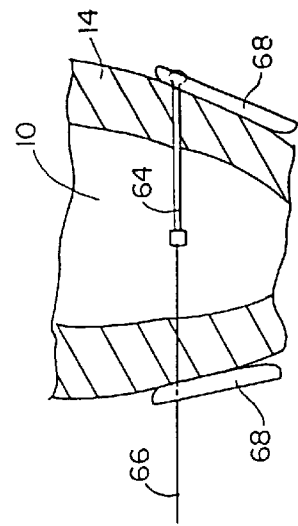

Fig. 27

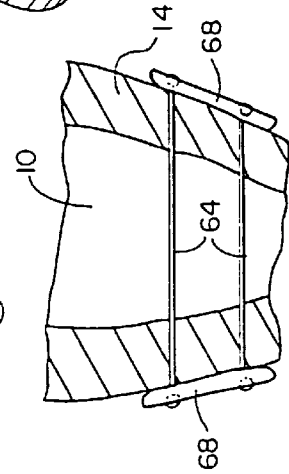

Fig. 28

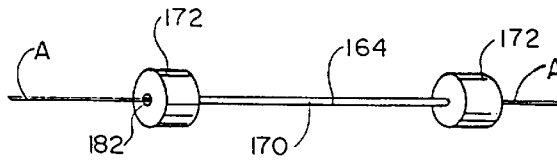

Fig. 29

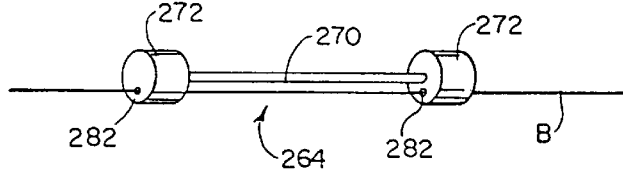

Fig. 30

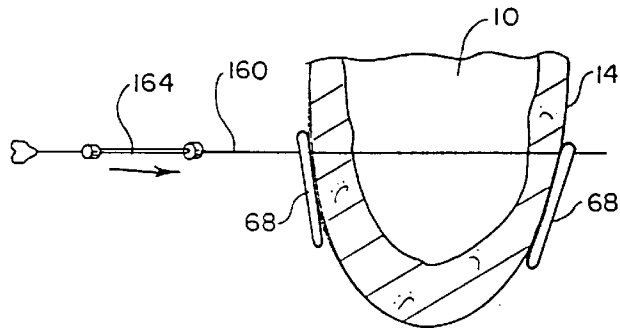

Fig. 31

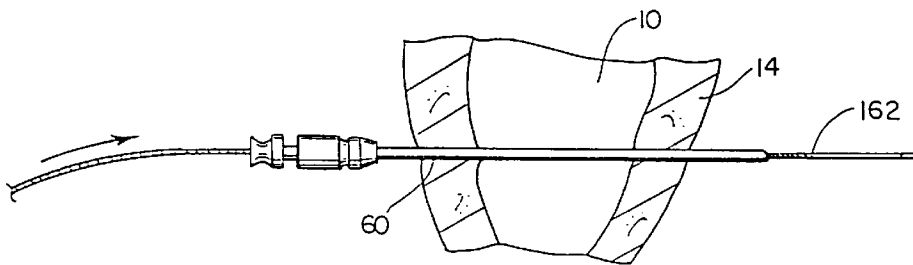

Fig. 32

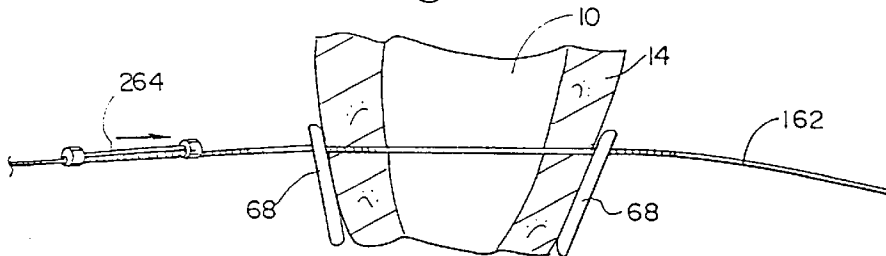

Fig. 33

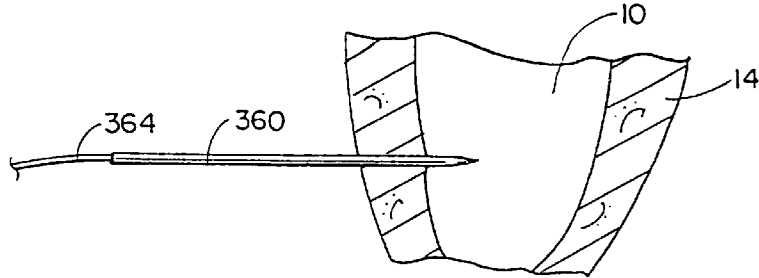

Fig. 34

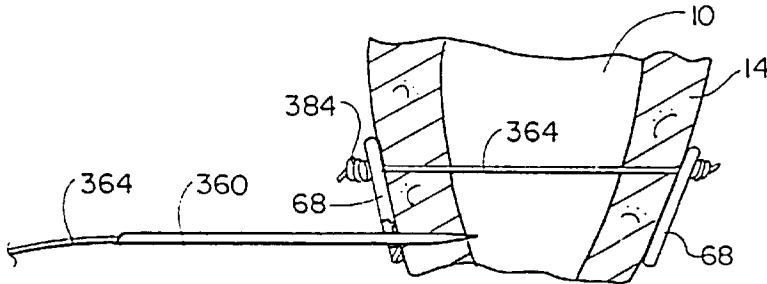

Fig. 35

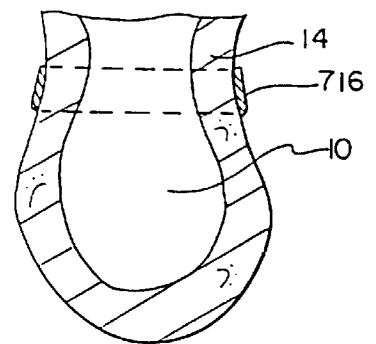

Fig. 36

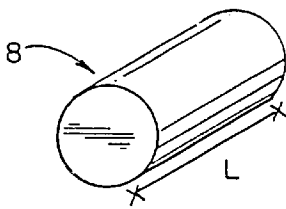

Fig. 37

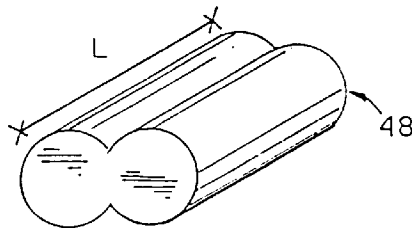

Fig. 38

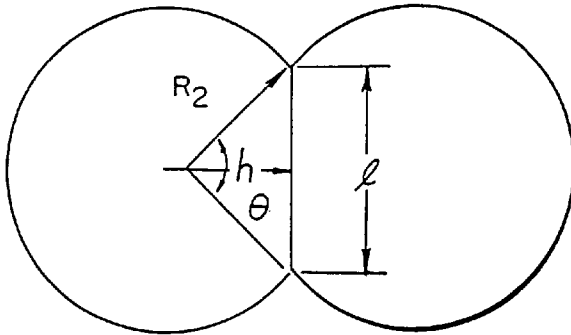

Fig. 39

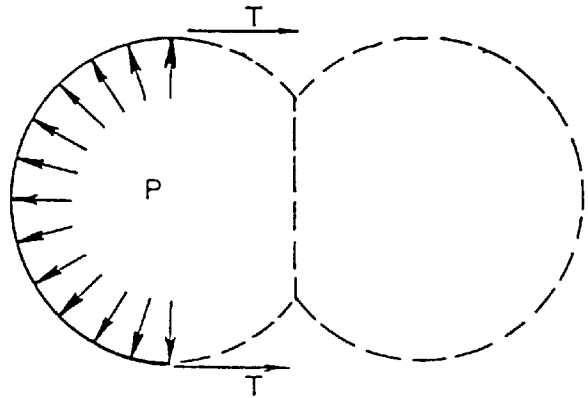
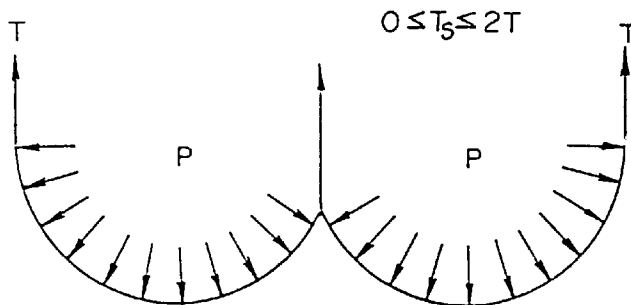

Fig. 40



HEART WALL TENSION REDUCTION APPARATUS AND METHOD

CROSS REFERENCE TO RELATED APPLICATION

This application is a continuation-in-part of U.S. application Ser. No. 08/778,277, filed Jan. 2, 1997, entitled "HEART WALL TENSION REDUCTION APPARATUS".

FIELD OF THE INVENTION

The present invention pertains to the field of apparatus for treatment of a failing heart. In particular, the apparatus of the present invention is directed toward reducing the wall stress in the failing heart.

BACKGROUND OF THE INVENTION

The syndrome of heart failure is a common course for the progression of many forms of heart disease. Heart failure may be considered to be the condition in which an abnormality of cardiac function is responsible for the inability of the heart to pump blood at a rate commensurate with the requirements of the metabolizing tissues, or can do so only at an abnormally elevated filling pressure. There are many specific disease processes that can lead to heart failure with a resulting difference in pathophysiology of the failing heart, such as the dilatation of the left ventricular chamber. Etiologies that can lead to this form of failure include idiopathic cardiomyopathy, viral cardiomyopathy, and ischemic cardiomyopathy.

The process of ventricular dilatation is generally the result of chronic volume overload or specific damage to the myocardium. In a normal heart that is exposed to long term increased cardiac output requirements, for example, that of an athlete, there is an adaptive process of slight ventricular dilation and muscle myocyte hypertrophy. In this way, the heart fully compensates for the increased cardiac output requirements. With damage to the myocardium or chronic volume overload, however, there are increased requirements put on the contracting myocardium to such a level that this compensated state is never achieved and the heart continues to dilate.

The basic problem with a large dilated left ventricle is that there is a significant increase in wall tension and/or stress both during diastolic filling and during systolic contraction. In a normal heart, the adaptation of muscle hypertrophy (thickening) and ventricular dilatation maintain a fairly constant wall tension for systolic contraction. However, in a failing heart, the ongoing dilatation is greater than the hypertrophy and the result is a rising wall tension requirement for systolic contraction. This is felt to be an ongoing insult to the muscle myocyte resulting in further muscle damage. The increase in wall stress is also true for diastolic filling. Additionally, because of the lack of cardiac output, there is generally a rise in ventricular filling pressure from several physiologic mechanisms. Moreover, in diastole there is both a diameter increase and a pressure increase over normal, both contributing to higher wall stress levels. The increase in diastolic wall stress is felt to be the primary contributor to ongoing dilatation of the chamber.

Prior art treatments for heart failure fall into three general categories. The first being pharmacological, for example, diuretics. The second being assist systems, for example, pumps. Finally, surgical treatments have been experimented with, which are described in more detail below.

With respect to pharmacological treatments, diuretics have been used to reduce the workload of the heart by reducing blood volume and preload. Clinically, preload is defined in several ways including left ventricular end diastolic pressure (LVEDP), or left ventricular end diastolic volume (LVEDV). Physiologically, the preferred definition is the length of stretch of the sarcomere at end diastole. Diuretics reduce extra cellular fluid which builds in congestive heart failure patients increasing preload conditions. Nitrates, arteriolar vasodilators, angiotensin converting enzyme inhibitors have been used to treat heart failure through the reduction of cardiac workload through the reduction of afterload. Afterload may be defined as the tension or stress required in the wall of the ventricle during ejection. Inotropes like digoxin are cardiac glycosides and function to increase cardiac output by increasing the force and speed of cardiac muscle contraction. These drug therapies offer some beneficial effects but do not stop the progression of the disease.

Assist devices include mechanical pumps and electrical stimulators. Mechanical pumps reduce the load on the heart by performing all or part of the pumping function normally done by the heart. Currently, mechanical pumps are used to sustain the patient while a donor heart for transplantation becomes available for the patient. Electrical stimulation such as bi-ventricular pacing have been investigated for the treatment of patients with dilated cardiomyopathy.

There are at least three surgical procedures for treatment of heart failure: 1) heart transplant; 2) dynamic cardiomyoplasty; and 3) the Batista partial left ventriculectomy. Heart transplantation has serious limitations including restricted availability of organs and adverse effects of immunosuppressive therapies required following heart transplantation. Cardiomyoplasty includes wrapping the heart with skeletal muscle and electrically stimulating the muscle to contract synchronously with the heart in order to help the pumping function of the heart. The Batista partial left ventriculectomy includes surgically remodeling the left ventricle by removing a segment of the muscular wall. This procedure reduces the diameter of the dilated heart, which in turn reduces the loading of the heart. However, this extremely invasive procedure reduces muscle mass of the heart.

SUMMARY OF THE INVENTION

The present invention pertains to a non-pharmacological, passive apparatus and method for the treatment of a failing heart. The device is configured to reduce the tension in the heart wall. It is believed to reverse, stop or slow the disease process of a failing heart as it reduces the energy consumption of the failing heart, decreases isovolumetric contraction, increases sarcomere shortening during contraction and increases isotonic shortening which in turn increases stroke volume. The device reduces wall tension during diastole and systole.

In one embodiment, the apparatus includes a tension member for drawing at least two walls of the heart chamber toward each other to reduce the radius or area of the heart chamber in at least one cross sectional plane. The tension member has anchoring members disposed at opposite ends for engagement with the heart or chamber wall.

In another embodiment, the apparatus includes a compression member for drawing at least two walls of a heart chamber toward each other. In one embodiment, the compression member includes a balloon. In another embodiment of the apparatus, a frame is provided for supporting the compression member.

Yet another embodiment of the invention includes a clamp having two ends biased toward one another for drawing at least two walls of a heart chamber toward each other. The clamp includes at least two ends having atraumatic anchoring member disposed thereon for engagement with the heart or chamber wall.

In yet another embodiment, a heart wall tension reduction apparatus is provided which includes a first tension member having two oppositely disposed ends and first and second elongate anchor members. A second tension member can be provided. One of the elongate anchors may be substituted for by two smaller anchors.

In an alternate embodiment of the heart wall tension reduction apparatus, an elongate compression member can be provided. First and second elongate lever members preferably extend from opposite ends of the compression member. A tension member extends between the first and second lever members.

The compression member of the above embodiment can be disposed exterior to, or internally of the heart. The tension member extends through the chamber or chambers to bias the lever members toward the heart.

In yet another embodiment of a heart wall tension reduction apparatus in accordance with the present invention, a rigid elongate frame member is provided. The frame member can extend through one or more chambers of the heart. One or more cantilever members can be disposed at opposite ends of the frame member. Each cantilever member includes at least one atraumatic pad disposed thereon. The atraumatic pads disposed at opposite ends of the frame member can be biased toward each other to compress the heart chamber.

One method of placing a heart wall tension apparatus or splint on a human heart includes the step of extending a hollow needle through at least one chamber of the heart such that each end of the needle is external to the chamber. A flexible leader is connected to a first end of a tension member. A second end of the tension member is connected to an atraumatic pad. The leader is advanced through the needle from one end of the needle to the other. The leader is further advanced until the second end of the tension member is proximate the heart and the first end of the tension member is external to the heart. A second atraumatic pad is connected to the first end of the tension member such that the first and second atraumatic pads engage the heart.

An alternate method of placing the heart wall tension reduction apparatus on the heart includes the step of extending a guide member through at least one chamber of the heart such that each end of the guide member is external to the chamber. A tension member for use in this method has at least one lumen extending through at least a portion of the member. The guide member is placed in the lumen. The tension member is advanced over the guide member such that a first end of the tension member is disposed to one side of and external to the heart and a second end of the tension member is disposed to an opposite side of and external to the heart. A first atraumatic pad is connected to one end of the tension member and a second atraumatic pad is connected to the opposite end of the tension member.

Yet another method of placing a heart wall tension apparatus on a heart includes the step of extending a needle having a flexible tension member releasably connected thereto through at least one chamber of the heart such that opposite ends of the tension member are external to the chamber and exposed on opposite sides of the chamber. The needle is removed from the tension member. Then first and second atraumatic pads are connected to the tension member at opposite ends of the tension member.

BRIEF DESCRIPTION OF THE DRAWINGS

FIG. 1 is a transverse cross-section of the left and right ventricles of a human heart showing the placement of a splint in accordance with the present invention;

FIG. 2 is a transverse cross-section of the left and right ventricles of a human heart showing the placement of a balloon device in accordance with the present invention;

FIG. 3 is a transverse cross-section of the left and right ventricles of a human heart showing the placement of an external compression frame structure in accordance with the present invention;

FIG. 4 is a transverse cross-section of the left and right ventricles of a human heart showing a clamp in accordance with the present invention;

FIG. 5 is a transverse cross-section of the left and right ventricles of a human heart showing a three tension member version of the splint of FIG. 1;

FIG. 6 is a transverse cross-section of the left and right ventricles of a human heart showing a four tension member version of the splint shown in FIG. 1;

FIG. 7 is a vertical cross-sectional view of the left ventricle of a human heart showing an alternate version of the splint in accordance with the present invention;

FIG. 8 is an end of the splint shown in FIG. 7;

FIG. 9 is a vertical cross-sectional view of a chamber of a human heart showing another alternative embodiment of the splint in accordance with the present invention;

FIG. 10 is a vertical cross-section of a chamber of a human heart showing another alternative configuration of splints in accordance with the present invention;

FIG. 11 is a vertical cross-sectional view of a chamber of a human heart showing another embodiment of a splint in accordance with the present invention;

FIG. 12 is a vertical cross-sectional view of a chamber of a human heart showing another embodiment of the splint in accordance with the present invention;

FIG. 13 is a vertical cross-sectional view of a chamber of a human heart showing a compression member version of the splint in accordance with the present invention;

FIG. 14 is a vertical cross-sectional view of a chamber of a human heart showing another version of the splint shown in FIG. 13;

FIG. 15 is a vertical cross-sectional view of a chamber of a human heart showing a frame member version of the splint in accordance with the present invention;

FIG. 16 is an end view of the splint of FIG. 15;

FIG. 17 is a vertical cross-section of the left ventricle and atrium, the left ventricle having scar tissue;

FIG. 18 is a vertical cross-section of the heart of FIG. 7 showing the splint of FIG. 1 drawing the scar tissue toward the opposite wall of the left ventricle;

FIG. 19 is a vertical cross-section of the left ventricle and atrium of a human heart showing a version of the splint of FIG. 1 having an elongate anchor bar;

FIG. 20 is a side view of an undeployed hinged anchor member;

FIG. 21 is a side view of a deployed hinged anchor member of FIG. 20;

FIG. 22 is a cross-sectional view of an captured ball anchor member;

FIG. 23 is a perspective view of a cross bar anchor member;

FIG. 24 is a vertical cross-sectional view of a chamber of a human heart showing a needle used for placement of splint in accordance with the present invention;

FIG. 25 is a view of the heart and needle of FIG. 24 showing a tension member being placed in the heart;

FIG. 26 is a view of the heart shown in FIG. 24 wherein oppositely disposed anchor pads are being joined by a tension member;

FIG. 27 is a view of the heart of FIG. 24, wherein two oppositely disposed anchor pads have been joined by two tension members;

FIG. 28 is a view of a tension member having a lumen extending therethrough;

FIG. 29 is a view of a tension member having lumens extending therethrough;

FIG. 30 is a vertical cross-sectional view of a chamber of the heart and two pads, and a needle extending therethrough;

FIG. 31 is a vertical cross-sectional view of a chamber of the heart showing a guidewire extending therethrough;

FIG. 32 is a view of the heart of FIG. 31, and two pads, and a guidewire extending therethrough;

FIG. 33 is a vertical cross-sectional view of a chamber of the heart showing a needle connected to a tension member being inserted into the chamber;

FIG. 34 is a vertical cross-sectional view of a chamber of a heart showing two anchors connected by a tension member;

FIG. 35 is a vertical cross-sectional view of a chamber of the heart, showing a band surrounding the heart;

FIG. 36 is a idealized cylindrical model of a left ventricle of a human heart;

FIG. 37 is a splinted model of the left ventricle of FIG. 14;

FIG. 38 is a transverse cross-sectional view of FIG. 15 showing various modeling parameters;

FIG. 39 is a transverse cross-section of the splinted left ventricle of FIG. 15 showing a hypothetical force distribution; and

FIG. 40 is a second transverse cross-sectional view of the model left ventricle of FIG. 15 showing a hypothetical force distribution.

DETAILED DESCRIPTION OF THE INVENTION

Referring now to the drawings wherein like reference numerals refer to like elements throughout the several views, FIG. 1 shows a transverse cross-section of a left ventricle 10 and a right ventricle 12 of a human heart 14. Extending through the left ventricle is a splint 16 including a tension member 18 and oppositely disposed anchors 20. Splint 16 as shown in FIG. 1 has been positioned to draw opposite walls of left ventricle 10 toward each other to reduce the "radius" of the left ventricular cross-section or the cross-sectional area thereof to reduce left ventricular wall stresses. It should be understood that although the splint 16 and the alternative devices disclosed herein are described in relation to the left ventricle of a human heart, these devices could also be used to reduce the radius or cross-sectional area of the other chambers of a human heart in transverse or vertical directions, or at an angle between the transverse and vertical.

FIG. 2 discloses an alternate embodiment of the present invention, wherein a balloon 200 is deployed adjacent the left ventricle. The size and degree of inflation of the balloon can be varied to reduce the radius or cross-sectional area of left ventricle 10 of heart 14.

FIG. 3 shows yet another alternative embodiment of the present invention deployed with respect to left ventricle 10 of human heart 14. Here a compression frame structure 300 is engaged with heart 14 at atraumatic anchor pads 310. A compression member 312 having an atraumatic surface 314 presses against a wall of left ventricle 10 to reduce the radius or cross-sectional area thereof.

FIG. 4 is a transverse cross-sectional view of human heart 14 showing yet another embodiment of the present invention. In this case a clamp 400 having atraumatic anchor pads 410 biased toward each other is shown disposed on a wall of left ventricle 10. Here the radius or cross-sectional area of left ventricle 10 is reduced by clamping off the portion of the wall between pads 410. Pads 410 can be biased toward each other and/or can be held together by a locking device.

Each of the various embodiments of the present invention disclosed in FIGS. 1-4 can be made from materials which can remain implanted in the human body indefinitely. Such biocompatible materials are well-known to those skilled in the art of clinical medical devices.

FIG. 5 shows an alternate embodiment of the splint of FIG. 1 referred to in FIG. 5 by the numeral 116. The embodiment 116 shown in FIG. 5 includes three tension members 118 as opposed to a single tension member 18 as shown in FIG. 1. FIG. 6 shows yet another embodiment of the splint 216 having four tension members 218. It is anticipated that in some patients, the disease process of the failing heart may be so advanced that three, four or more tension members may be desirable to reduce the heart wall stresses more substantially than possible with a single tension member as shown in FIG. 1.

FIG. 7 is a partial vertical cross-section of human heart 14 showing left ventricle 10. In FIG. 7, another splint embodiment 316 is shown having a tension member 318 extending through left ventricle 10. On opposite ends of tension member 318 are disposed elongate anchors or pads 320. FIG. 8 is an end view of tension member 318 showing elongate anchor 320.

FIG. 9 shows another embodiment of a splint 416 disposed in a partial vertical cross-section of human heart 14. Splint 416 includes two elongate anchors or pads 420 similar to those shown in FIGS. 7 and 8. In FIG. 9, however, two tension members 418 extend through left ventricle 10 to interconnect anchors 420 on opposite sides of heart 14.

FIG. 10 is a vertical cross section of heart 14 showing left ventricle 10. In this case, two splints 16 are disposed through left ventricle 10 and vertically spaced from each other to resemble the configuration of FIG. 9.

FIG. 11 is a vertical cross sectional view of the left ventricle of heart 14. Two alternate embodiment splints 516 are shown extending through left ventricle 10. Each splint 516 includes two tension members 518 interconnecting two anchors or pads 520.

FIG. 12 is yet another vertical cross sectional view of left ventricle 10 of heart 14. An alternate embodiment 616 of the splint is shown extending through left ventricle 10. Splint 616 includes an elongate anchor pad 620 and two shorter anchors or pads 621. Splint 616 includes two tension members 618. Each tension member 618 extends between anchors 620 and respective anchors 621.

FIG. 13 is a vertical cross sectional view of left ventricle 10 of heart 14. A splint 50 is shown disposed on heart 14. Splint 50 includes a compression member 52 shown extending through left ventricle 10. Opposite ends of compression member 52 are disposed exterior to left ventricle 10. Lever members 54 extend from each end of compression member

52 upwardly along the exterior surface of ventricle **10**. A tension member **56** extends between lever members **54** to bias lever members **54** toward heart **14** to compress chamber **10**.

Compression member **52** should be substantially rigid, but lever members **54** and to some degree compression member **52** should be flexible enough to allow tension member **56** to bias lever members **54** toward heart **14**. Alternately, lever members **54** could be hinged to compression member **52** such that lever members **54** could pivot about the hinge when biased toward heart **14** by tension member **56**.

FIG. **14** shows an alternate embodiment **156** of the splint shown in FIG. **13**. In this case lever members **154** are longer than members **54** as compression member **152** of splint **150** has been disposed to the exterior of left ventricle **10**.

FIG. **15** is a vertical cross sectional view of left ventricle **10** of heart **14**. An alternate embodiment **250** of the splint is shown on heart **14**. A preferably relatively rigid frame member **256** extends through ventricle **10**. Disposed on opposite ends of frame **250** are cantilever member **254**. Disposed on cantilever members **254** are atraumatic pads **258**. Cantilever members **254** can be positioned along frame member **256** such that atraumatic pads **258** press against heart **14** to compress chamber **10**. FIG. **16** is an end view of frame member **256** showing cantilever members **254** and pads **258**.

It should be understood that each of the embodiments described above should be formed from suitable biocompatible materials known to those skilled in the art. The tension members can be formed from flexible or relatively more rigid material. The compression members and frame member should be formed from generally rigid material which may flex under load, but generally hold its shape.

FIG. **17** is a partial vertical cross-section of human heart **14** showing left ventricle **10** and left atrium **22**. As shown in FIG. **7**, heart **14** includes a region of scar tissue **24** associated with an aneurysm or ischemia. As shown in FIG. **7**, the scar tissue **24** increases the radius or cross-sectional area of left ventricle **10** in the region affected by the scar tissue. Such an increase in the radius or cross-sectional area of the left ventricle will result in greater wall stresses on the walls of the left ventricle.

FIG. **18** is a vertical cross-sectional view of the heart **14** as shown in FIG. **7**, wherein a splint **16** has been placed to draw the scar tissue **24** toward an opposite wall of left ventricle **10**. As a consequence of placing splint **16**, the radius or cross-sectional area of the left ventricle affected by the scar tissue **24** is reduced. The reduction of this radius or cross-sectional area results in reduction in the wall stress in the left ventricular wall and thus improves heart pumping efficiency.

FIG. **19** is a vertical cross-sectional view of left ventricle **10** and left atrium **22** of heart **14** in which a splint **16** has been placed. As shown in FIG. **9**, splint **16** includes an alternative anchor **26**. The anchor **26** is preferably an elongate member having a length as shown in FIG. **9** substantially greater than its width (not shown). Anchor bar **26** might be used to reduce the radius or cross-sectional area of the left ventricle in an instance where there is generalized enlargement of left ventricle **10** such as in idiopathic dilated cardiomyopathy. In such an instance, bar anchor **26** can distribute forces more widely than anchor **20**.

FIGS. **20** and **21** are side views of a hinged anchor **28** which could be substituted for anchors **20** in undeployed and deployed positions respectively. Anchor **28** as shown in FIG.

20 includes two legs similar to bar anchor **26**. Hinged anchor **28** could include additional legs and the length of those legs could be varied to distribute the force over the surface of the heart wall. In addition there could be webbing between each of the legs to give anchor **28** an umbrella-like appearance. Preferably the webbing would be disposed on the surface of the legs which would be in contact with the heart wall.

FIG. **22** is a cross-sectional view of a capture ball anchor **30**. Capture ball anchor **30** can be used in place of anchor **20**. Capture ball anchor **30** includes a disk portion **32** to distribute the force of the anchor on the heart wall, and a recess **34** for receiving a ball **36** affixed to an end of tension member **18**. Disk **32** and recess **34** include a side groove which allows tension member **38** to be passed from an outside edge of disk **32** into recess **34**. Ball **36** can then be advanced into recess **34** by drawing tension member **18** through an opening **38** in recess **34** opposite disk **32**.

FIG. **23** is a perspective view of a cross bar anchor **40**. The cross bar anchor **40** can be used in place of anchors **20**. The anchor **40** preferably includes a disk or pad portion **42** having a cross bar **44** extending over an opening **46** in pad **42**. Tension member **18** can be extended through opening **46** and tied to cross bar **42** as shown.

In use, the various embodiments of the present invention are placed in or adjacent the human heart to reduce the radius or cross-section area of at least one chamber of the heart. This is done to reduce wall stress or tension in the heart or chamber wall to slow, stop or reverse failure of the heart. In the case of the splint **16** shown in FIG. **1**, a canula can be used to pierce both walls of the heart and one end of the splint can be advanced through the canula from one side of the heart to the opposite side where an anchor can be affixed or deployed. Likewise, an anchor is affixed or deployed at the opposite end of splint **16**.

FIG. **24** is a vertical cross-sectional view of a chamber **10** of a heart **14**. A needle **60** having a stylet inserted there-through is inserted through chamber **10**. FIG. **25** shows needle **60** disposed in heart **40** as shown in FIG. **24**. In FIG. **25**, stylet **62** has been removed. A tension member **64** having a flexible leader **66** attached to one end of tension member **64**, is threaded through needle **60** and an anchor **68**.

As shown in FIG. **25**, tension member **64** includes a generally elongate cylindrical shaft **70** having two generally cylindrical ends **72**. Ends **72** preferably have a greater diameter than shaft **70**. Also shown in FIG. **25** is a perspective view of anchor **68** showing an opening **73** extending through anchor **68**. Opening **73** includes a first cylindrically shaped opening **74** extending entirely through anchor **68**. The diameter of opening **74** is preferably slightly greater than the diameter of end **72** of tension member **64**. A groove **76** having a width preferably slightly greater than that of shaft **70** of tension member **64** extends from opening **74** to a generally cylindrical opening **78**. Generally cylindrical opening **78** has a diameter approximately equal to end **72**. Unlike opening **74**, however, opening **78** includes a reduced base opening **80** which has a width approximately equal to that of groove **76**. The width of the opening **80** is also less than the diameter of end **72** of tension member **64**.

It can be appreciated that tension member **64** can be advanced through opening **74** until shaft **70** is disposed therein. Shaft **70** can be then slid transversely through groove **76**. Tension member **64** can then be advanced further through opening **73** until end portion **72** enters opening **78** and seats against base **80**.

FIG. **26** shows the view of heart **14** shown in FIG. **25**. Needle **60** has been removed from heart **14**. Tension member

64 has been advanced into chamber 10 and anchor 68 connected thereto is engaging the heart wall. Leader 66 has been advanced through yet another anchor 68 disposed on the opposite side of heart 14.

FIG. 27 is a view of heart 14 of FIG. 26. Two tension member 64 have been advanced through chamber 10. Each tension member has been seated in respective opening 78 against respective bases 80 to form a splint in a configuration such as that shown in FIG. 9.

It can be appreciated that each of the other tension member splints configurations can be placed on the heart in a similar manner. It can also be appreciated that anchors 68 could initially be held against the heart and needle 60 advanced through anchors 68 and chamber 10 prior to extending leader 66 through the needle.

FIG. 28 is a perspective view of a tension member 164 in accordance with the present invention. Tension member 164 is similar to tension member 64 described above in that it has an elongate, generally cylindrical shaft 170 and generally cylindrical ends 172. A lumen, however, extends longitudinally through tension member 164 along axis A.

FIG. 29 is a perspective view of yet another embodiment of the tension member 264. Tension member 264, is similar to tension member 164, and includes an elongate cylindrical shaft 270 and cylindrical ends 272. Lumens 282, however, extend through ends 272 aligned along axis B.

FIG. 30 is a vertical, cross-sectional view of left ventricle 10 of heart 14. Anchors 68 have been placed on opposite sides of heart 14. A needle 160 extends through the lumen of tension member 164, left ventricle 10 and openings 73 in anchors 68. It can be appreciated that tension member 64 can be advanced through anchors 68 and left ventricle 10 and be seated within openings 78 as described above with respect to tension member 64.

FIG. 31 is a vertical, cross-sectional view of left ventricle 10 of heart 14. A needle 60 has been advanced through the wall of left ventricle 10 and a guidewire 162 has been advanced through needle 60.

FIG. 32 is the same view of heart 14 as shown in FIG. 32. Needle 60, however, has been removed from heart 14 while guidewire 162 remains in position. Anchors 68 have been placed on guidewire 162, on opposite sides of left ventricle 10. Tension member 264 has been threaded onto guidewire 162 through lumens 282. It can be appreciated that as discussed above with respect to tension member 164 above, tension member 264 can be advanced through left ventricle 10 such that ends 272 of tension member 264 seat in respective openings 78 against base 80.

FIG. 33 is a vertical, cross-sectional view of left ventricle 10 of heart 14. In FIG. 34, flexible tension member 364 has been connected to a needle 360. Needle 360 is shown being advanced into left ventricle 10 through a ventricle wall.

FIG. 34 is the same view of heart 14 as shown in FIG. 33 except that tension member 364 has been advanced entirely through left ventricle 10 and anchors 68. Knots 384 have been tied at the ends of tension member 364 to prevent the ends of tension member 364 from passing through opening 73 of anchors 68.

It can be appreciated that the methods described above to advance the tension members through the ventricles can be repeated to advance the desired number of tension members through the ventricle for a particular configuration. The length of the tension members can be determined based upon the size and condition of the patient's heart. It should also be noted that although the left ventricle has been

referred to here for illustrative purposes, that the apparatus and methods of this invention can also be used to splint multiple chambers of a patient's heart as well as the right ventricle or either atrium.

FIG. 35 is a vertical cross-section of left ventricle 10 of heart 14. Disposed about heart 14 is a band 716. Band 716 is shown as being sized relative to the heart such that the heart's radius or cross-sectional area in a plane parallel to the length of the band is reduced relative to the radius at that location prior to placement of the band on the heart. The length of the heart perpendicular to the band is also increased. The band may be formed from a continuous ribbon of elastomeric material or from other biocompatible materials which are sufficiently strong to provide the desired effect of heart radius reduction and lengthening.

FIG. 36 is a view of a cylinder or idealized heart chamber 48 which is used to illustrate the reduction of wall stress in a heart chamber as a result of deployment of the splint in accordance with the present invention. The model used herein and the calculations related to this model are intended merely to illustrate the mechanism by which wall stress is reduced in the heart chamber. No effort is made herein to quantify the actual reduction which would be realized in any particular in vivo application.

FIG. 37 is a view of the idealized heart chamber 48 of FIG. 36 wherein the chamber has been splinted along its length L such that a "figure eight" cross-section has been formed along the length thereof. It should be noted that the perimeter of the circular transverse cross-section of the chamber in FIG. 36 is equal to the perimeter of the figure eight transverse cross-section of FIG. 37. For purposes of this model, opposite lobes of the figure in cross-section are assumed to be mirror images.

FIG. 38 shows various parameters of the FIG. 1 cross-section of the splinted idealized heart chamber of FIG. 37. Where l is the length of the splint between opposite walls of the chamber, R₂ is the radius of each lobe, θ is the angle between the two radii of one lobe which extends to opposite ends of the portion of the splint within chamber 48 and h is the height of the triangle formed by the two radii and the portion of the splint within the chamber 48 (R₁ is the radius of the cylinder of FIG. 36). These various parameters are related as follows:

$$h=R_2 \cos (\theta / 2)$$

$$l=2 R_2 \sin (\theta / 2)$$

$$R_2=R_1 \pi / (2 \pi - \theta)$$

From these relationships, the area of the figure eight cross-section can be calculated by:

$$A_2=2 \pi\left(R_2\right)^2(1-\theta / 2 \pi)+h l$$

Where chamber 48 is unsplinted as shown in FIG. 36 A₁, the original cross-sectional area of the cylinder is equal to A₂ where θ=180°, h=0 and l=2R₂. Volume equals A₂ times length L and circumferential wall tension equals pressure within the chamber times R₂ times the length L of the chamber.

Thus, for example, with an original cylindrical radius of four centimeters and a pressure within the chamber of 140 mm of mercury, the wall tension T in the walls of the cylinder is 104.4 newtons. When a 3.84 cm splint is placed as shown in FIGS. 37 and 38 such that l=3.84 cm, the wall tension T is 77.33 newtons.

FIGS. 39 and 40 show a hypothetical distribution of wall tension T and pressure P for the figure eight cross-section. As

11

θ goes from 180° to 0° , tension T_s in the splint goes from 0 to a $2T$ load where the chamber walls carry a T load.

In yet another example, assuming that the chamber length L is a constant 10 cm, the original radius R_1 is 4 cm, at a 140 mmHg the tension in the walls is 74.7 N. If a 4.5 cm splint is placed such that $l=4.5$ cm, the wall tension will then be 52.8 N.

It will be understood that this disclosure, in many respects, is only illustrative. Changes may be made in details, particularly in matters of shape, size, material, and arrangement of parts without exceeding the scope of the invention. Accordingly, the scope of the invention is as defined in the language of the appended claims.

What is claimed is:

1. A heart wall tension reduction apparatus, comprising: an elongate compression member having first and second ends; first and second elongate lever members, the first lever member extending from the first end of the compression member, and the second lever member extending from the second end of the compression member; and a tension member extending between the first and second lever members.
2. The heart wall tension reduction apparatus in accordance with claim 1, wherein each of the two lever members have two ends, one end of each of the two lever members is disposed proximate the compression member, the other end of each of the two lever members is disposed remotely from the compression member, and the tension member is disposed closer to the ends of the two lever members disposed proximate the compression member than the ends disposed remotely therefrom.
3. A method of disposing a heart wall tension reduction apparatus on a human heart having a plurality of chambers, comprising the steps of:
 - providing a heart wall tension reduction apparatus including an elongate compression member having first and second ends; first and second elongate lever members, the first lever member extending from the first end of the compression member, and the second lever member extending from the second end of the compression member; a tension member extending between the first and second lever members; and
 - extending the tension member through at least one chamber of the human heart.
4. The method in accordance with claim 3, further comprising the step of disposing the compression member external to the heart.
5. The method in accordance with claim 3, further comprising the step of disposing at least a portion of the compression member within the heart.
6. A heart wall tension reduction apparatus, comprising:
 - a rigid elongate frame member having a first end and a second end;
 - a first cantilever member disposed at the first end of the frame member; and
 - a second cantilever member disposed at the second end of the frame member.
7. The heart wall tension reduction apparatus in accordance with claim 6, wherein each cantilever member includes at least one atraumatic pad disposed thereon.
8. The heart wall tension reduction apparatus in accordance with claim 6, further comprising a plurality of cantilever members disposed at the first and second ends of the frame member.
9. A method of placing a heart wall tension reduction apparatus on a human heart having a plurality of chambers, comprising the steps of:

12

extending a hollow needle through at least one chamber of the heart such that each end of the needle is external to the heart;

providing a tension member having first and second ends; connecting the second end of the tension member to a first atraumatic pad;

advancing the tension member through the needle from one end of the needle to the other;

further advancing the tension member until the first atraumatic pad engages the heart and the first end of the tension member is external to the at least one chamber; and

connecting the first end of the tension member to a second atraumatic pad such that the second atraumatic pad engages the heart.

10. The method in accordance with claim 9, wherein the length of the tension member is such that the at least one chamber of the heart is compressed between the first and second atraumatic pads.

11. A method of placing a heart wall tension reduction apparatus on a heart having a plurality of chambers, comprising the steps of:

extending a guide member through at least one chamber of the heart such that each end of the guide member is external to the chamber;

providing a tension member having at least one lumen extending therethrough;

extending a portion of the guide member through the lumen;

advancing the tension member on the guide member such that a first end of the tension member is disposed to one side of and external to the at least one chamber, and a second end of the tension member is disposed to an opposite side of and external to the at least one chamber; and

connecting a first atraumatic pad to the first end and a second atraumatic pad to the second end of the tension member.

12. The method in accordance with claim 11, wherein the length of the tension member is such that the at least one chamber of the heart is compressed between the first and second atraumatic pads.

13. The method in accordance with claim 11, wherein the guide member includes a needle.

14. The method in accordance with claim 11, wherein the guide member includes a guidewire.

15. A method of placing a heart wall tension reduction apparatus on a heart having a plurality of chamber comprising the steps of:

extending a needle having a flexible tension member releasably connected thereto through at least one chamber of the heart such that opposite ends of the tension member are external to the chamber and exposed on opposite sides thereof;

removing the needle from the tension member; and connecting a first atraumatic pad to one end of the tension member and a second atraumatic pad to the opposite end of the tension member.

16. The method in accordance with claim 15, wherein the length of the tension member is such that the at least one chamber of the heart is compressed between the first and second atraumatic pads.

17. A heart wall tension reduction apparatus, comprising: a first generally linear elongate tension member for drawing at least two walls of a chamber of the heart toward

13

each other, the tension member having two oppositely disposed ends;

- a plurality of anchors, including an elongate anchor having a first end and a second end, one end of the first tension member being connected to the first end of the elongate anchor, and the opposite end of the first tension member being connected to one anchor to secure the tension member to the heart; and
- a second generally elongate tension member for drawing at least two walls of a chamber of the heart toward each other, the second tension member having two oppositely disposed ends, wherein one end of the second tension member is connected to the second end of the elongate anchor and the opposite end of the second tension member is connected to one of the anchors such that where the tension members are disposed between the anchors, the tension members are spaced from each other.

18. The heart wall tension reduction apparatus in accordance with claim **17**, wherein the ends of the tension

14

members not connected to the elongate anchor, are each connected to different anchors.

19. The heart wall tension reduction apparatus in accordance with claim **18**, wherein the elongate anchor, the anchor connected to the opposite end of the first tension member, and the anchor member connected to the opposite end of the second tension member comprise anchor pads.

20. An apparatus for the treatment of a failing heart, comprising:

- a generally linear, substantially rigid, elongate tension member for drawing at least two walls of a chamber of the heart toward each other, the tension member having two oppositely disposed ends; and

an anchor disposed at each end of the tension member, configured to secure the tension member to the heart wall.

* * * * *

UNITED STATES PATENT AND TRADEMARK OFFICE
CERTIFICATE OF CORRECTION

PATENT NO. : 5,961,440
DATED : October 5, 1999
INVENTOR(S) : Cyril J. SCHWEICH, Jr. et al.

It is certified that error appears in the above-identified patent and that said Letters Patent is hereby corrected as shown below:

Claim 15, col. 12, line 49, "chamber" should read --chambers--.

Claim 17, col. 12, line 65, "comprising;" should read --comprising:--.

Signed and Sealed this
Fourth Day of April, 2000

Attest:



Q. TODD DICKINSON

Attesting Officer

Director of Patents and Trademarks