

(21) Application No: 0404826.0  
(22) Date of Filing: 12.06.2001  
Date Lodged: 03.03.2004  
(30) Priority Data:  
(31) 60212359 (32) 19.06.2000 (33) US  
(62) Divided from Application No  
0229708.3 under Section 15(4) of the Patents Act 1977

(51) INT CL<sup>7</sup>:  
E21B 43/10 23/01  
(52) UK CL (Edition W ):  
E1F FAC FAC9 FK FKG FLA F204  
(56) Documents Cited:  
GB 2356651 A WO 2001/004535 A  
(58) Field of Search:  
UK CL (Edition W ) E1F  
INT CL<sup>7</sup> E21B  
Other: Online: WPI, EPODOC

(71) Applicant(s):  
Shell Oil Company  
(Incorporated in USA - Texas)  
910 Louisiana Street, Houston,  
Texas 77252-2463,  
United States of America

(72) Inventor(s):  
Robert Lance Cook  
Richard Carl Haut

(continued on next page)

(54) Abstract Title: **A system for coupling an expandable tubular member to a preexisting structure**

(57) A tubular member 140 is anchored to a wellbore casing 100 by pressurising an expandable element 150. An expansion cone 130 having lubricating grooves and passages is then axially displaced by applying an axial force to a support member 125. The axial pressure may be enhanced by injecting a pressurized fluid into the annular space between support members 120,125. Various other anchoring devices are disclosed.

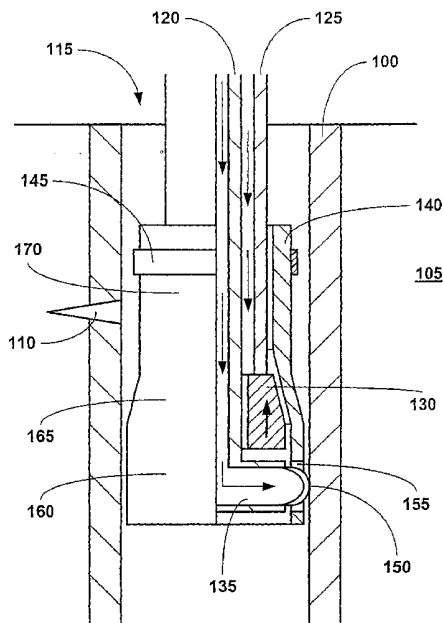

FIGURE 1d

**GB 2396640 A continuation**

(72) cont

**Lev Ring**  
**Thomas Patrick Grant III**  
**Edwin Arnold Zwald Jr**  
**Andrei Gregory Filippov**

(74) Agent and/or Address for Service:

**Haseltine Lake & Co**  
**Imperial House, 15-19 Kingsway,**  
**LONDON, WC2B 6UD, United Kingdom**

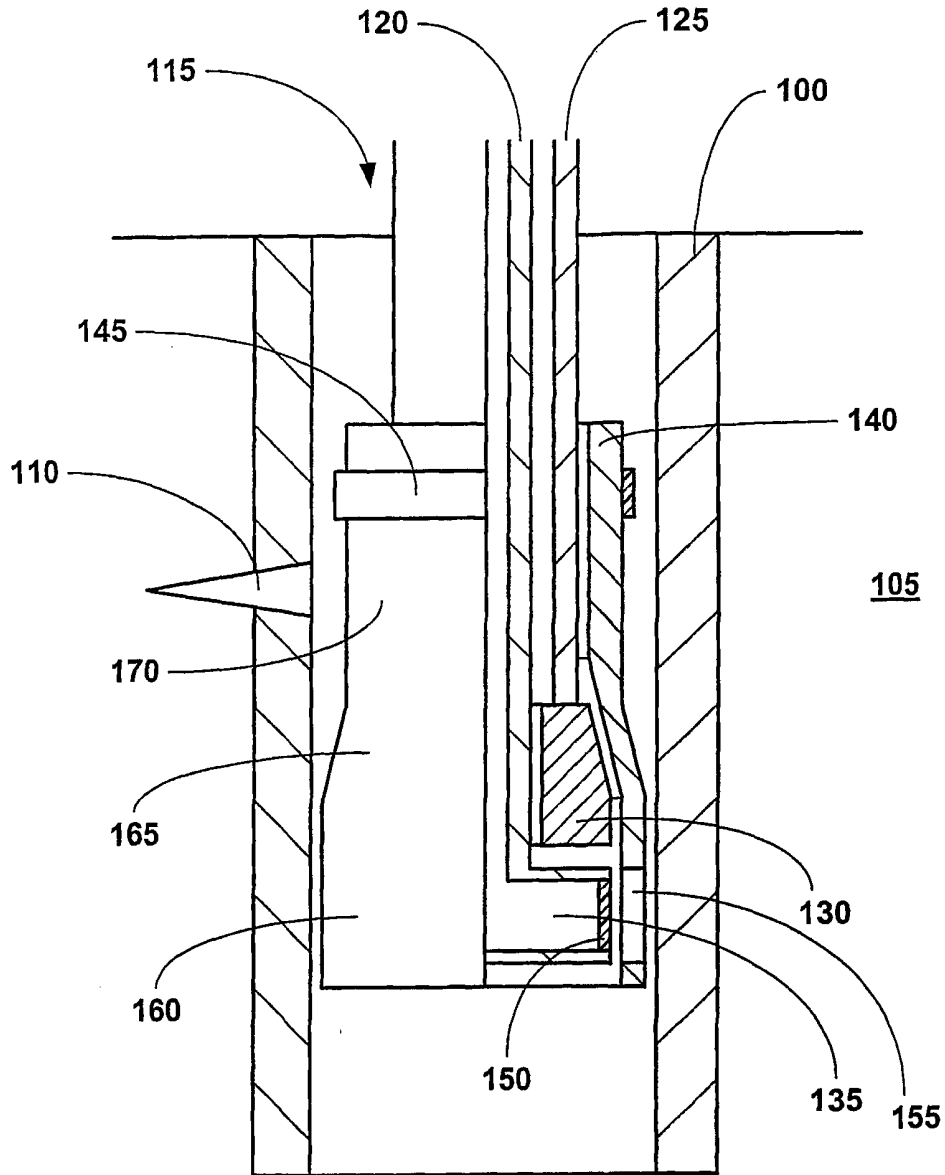

FIGURE 1a

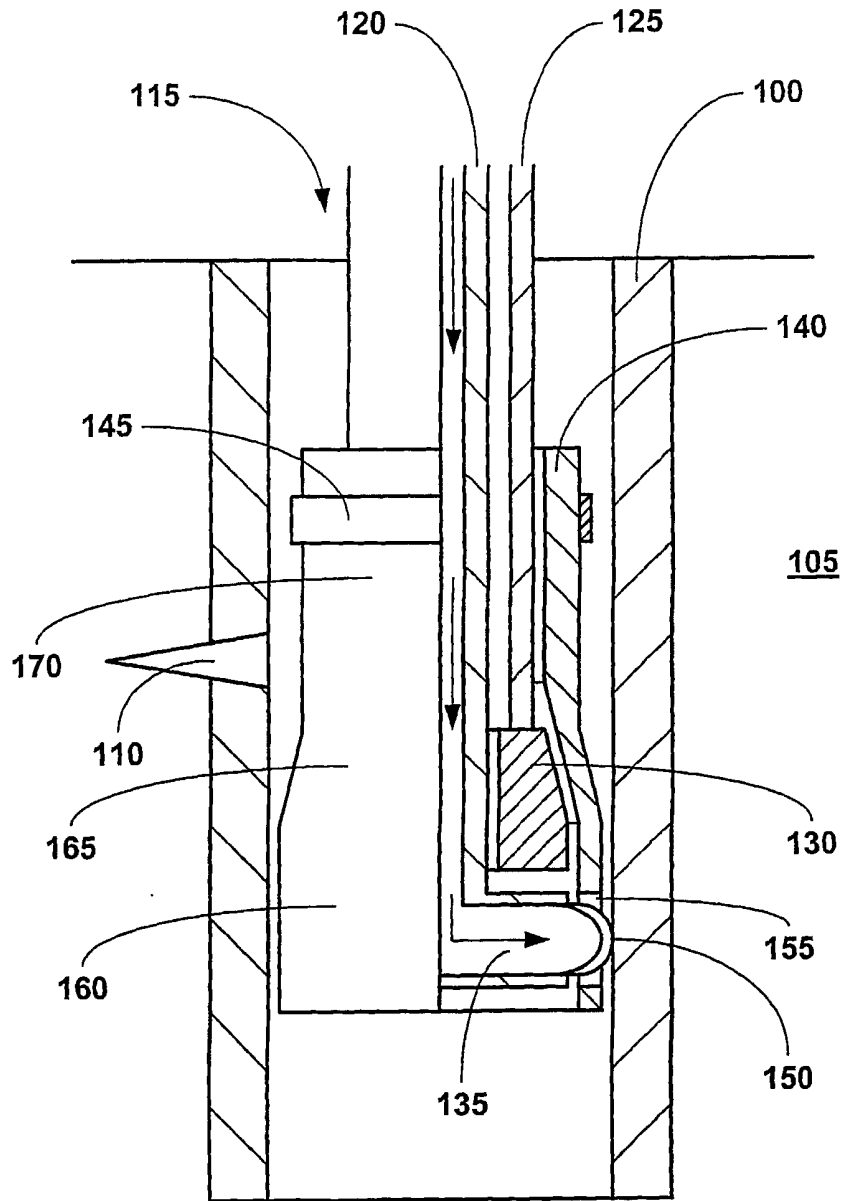

FIGURE 1b

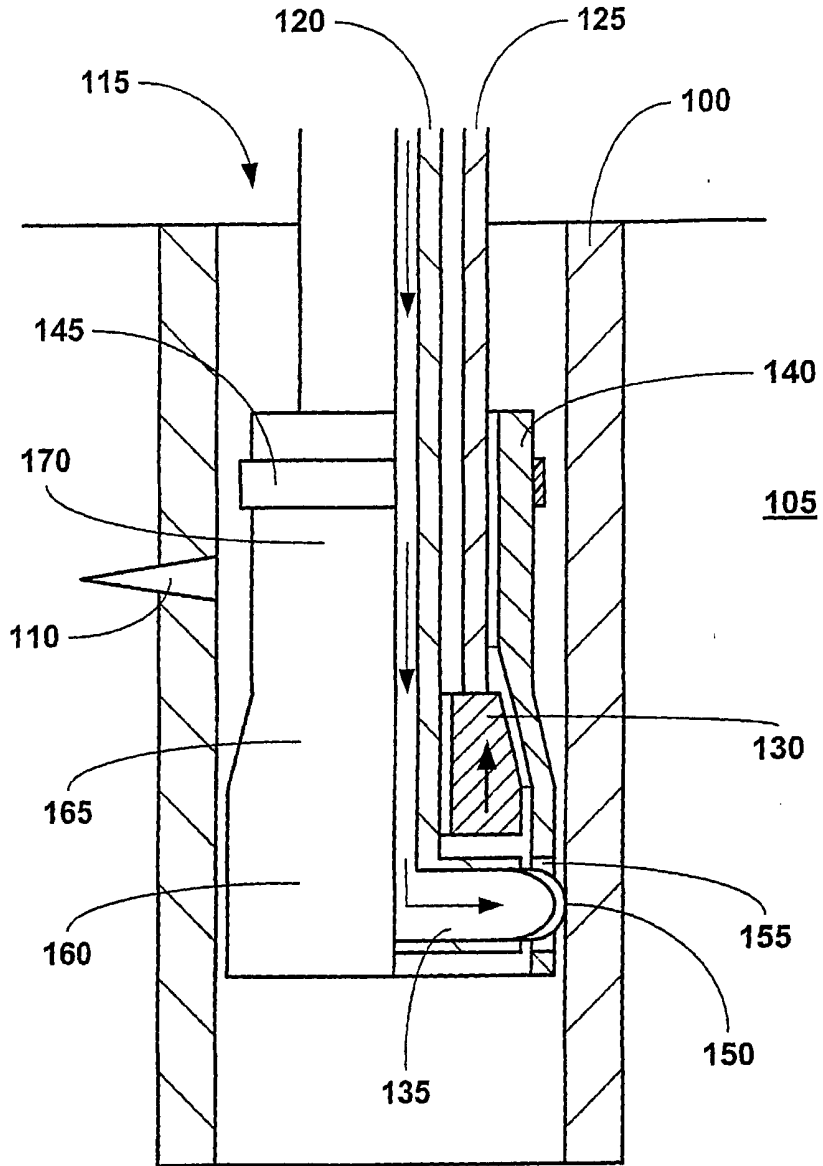

FIGURE 1c

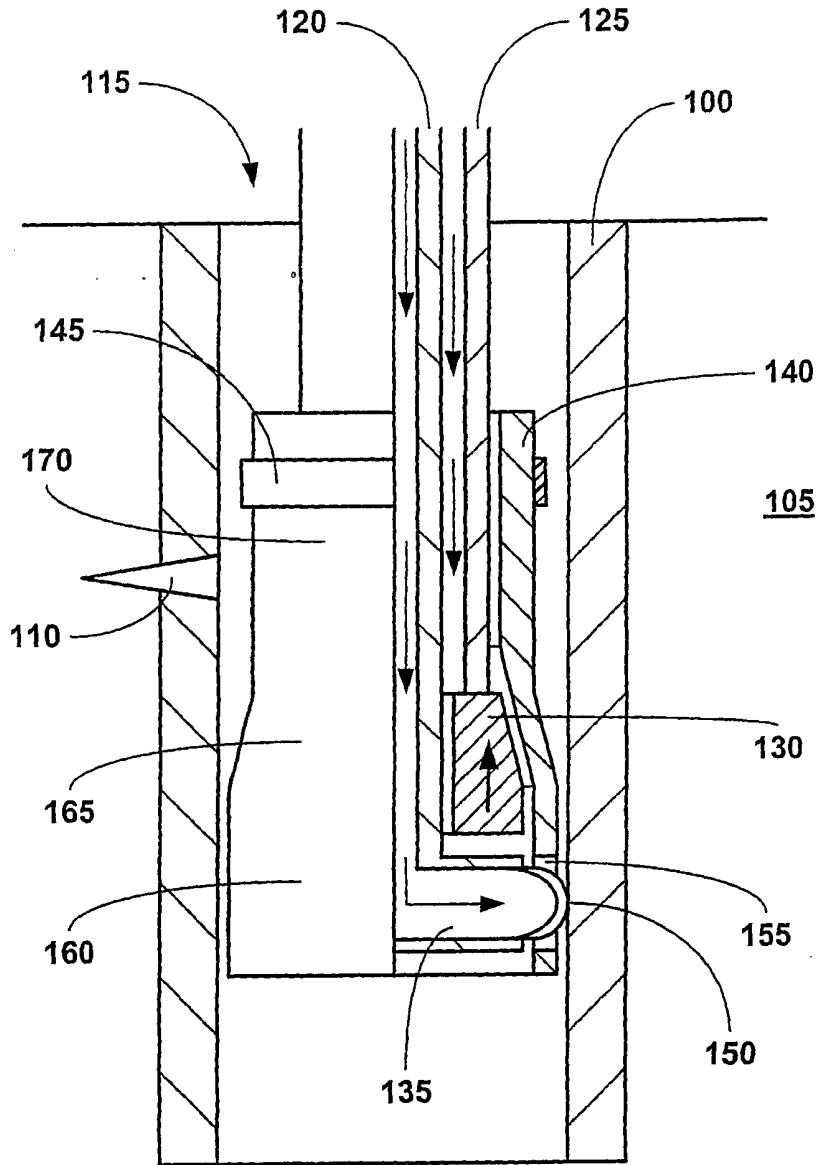

FIGURE 1d

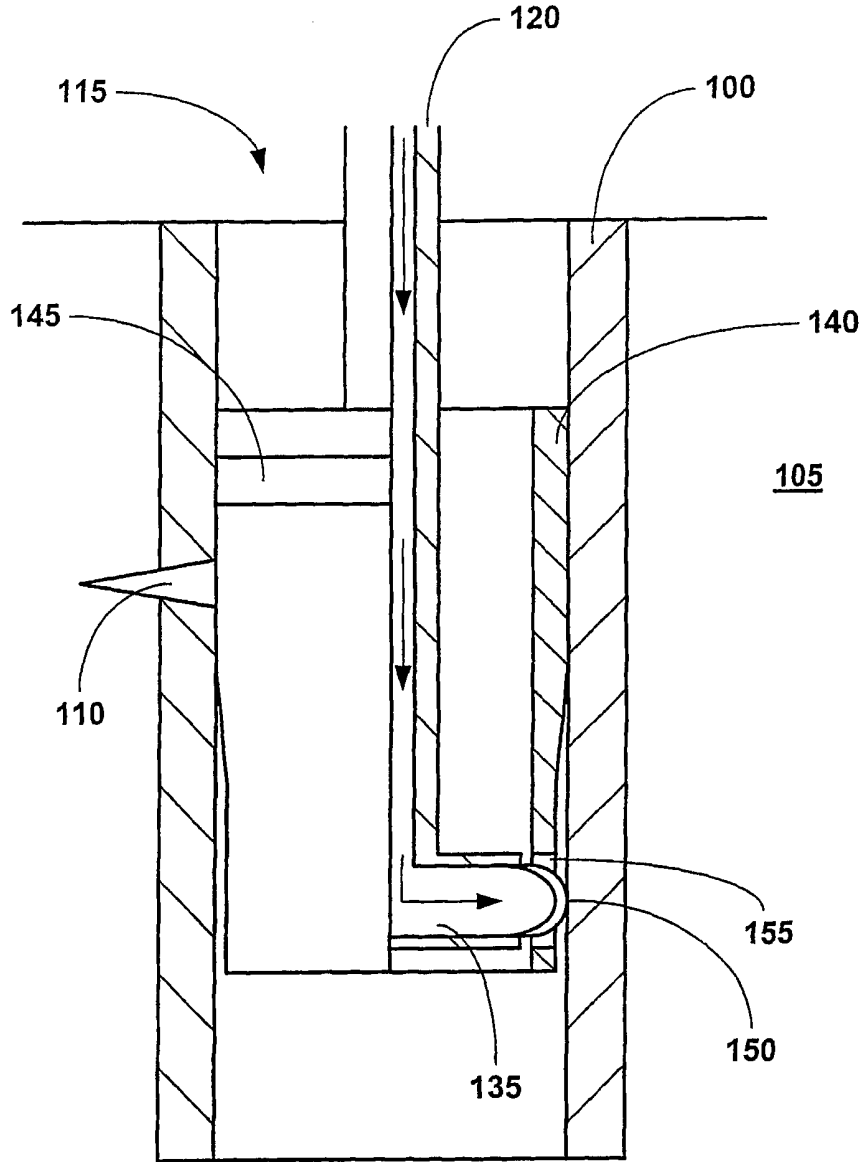

FIGURE 1e

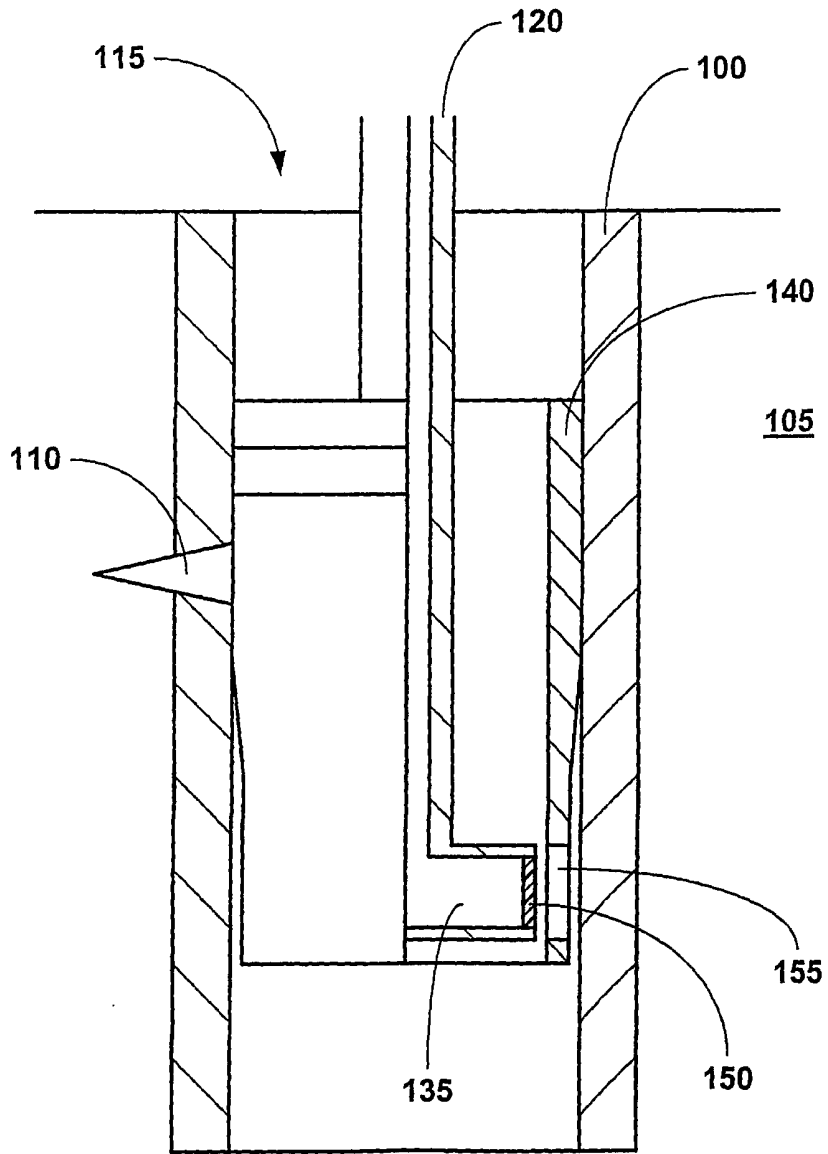

FIGURE 1f



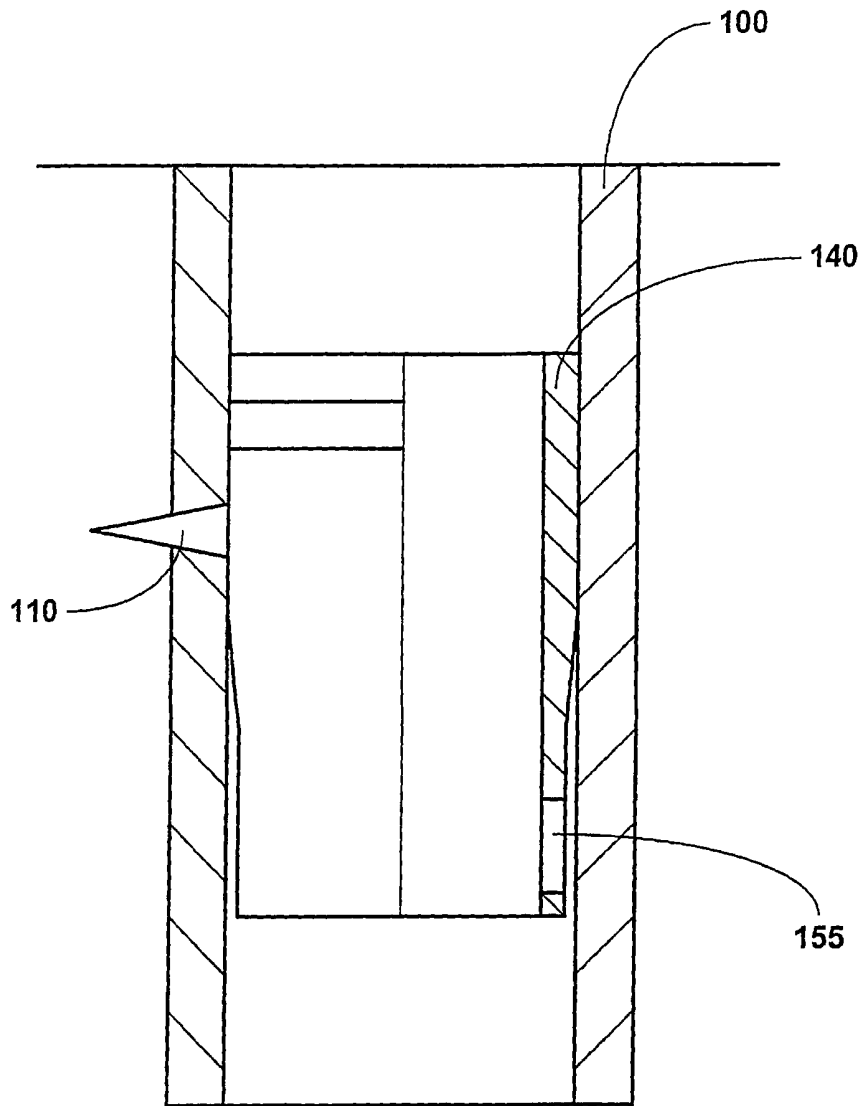

FIGURE 1g

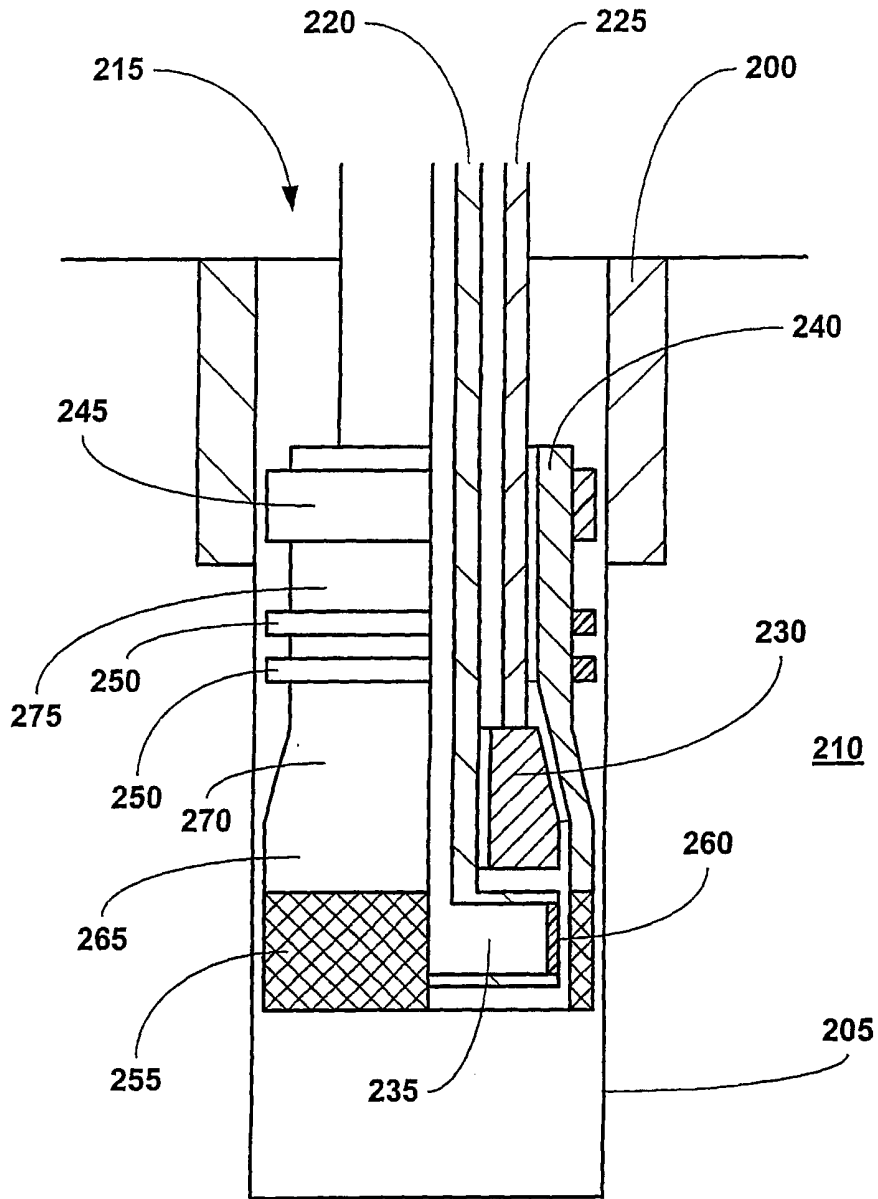

FIGURE 2a

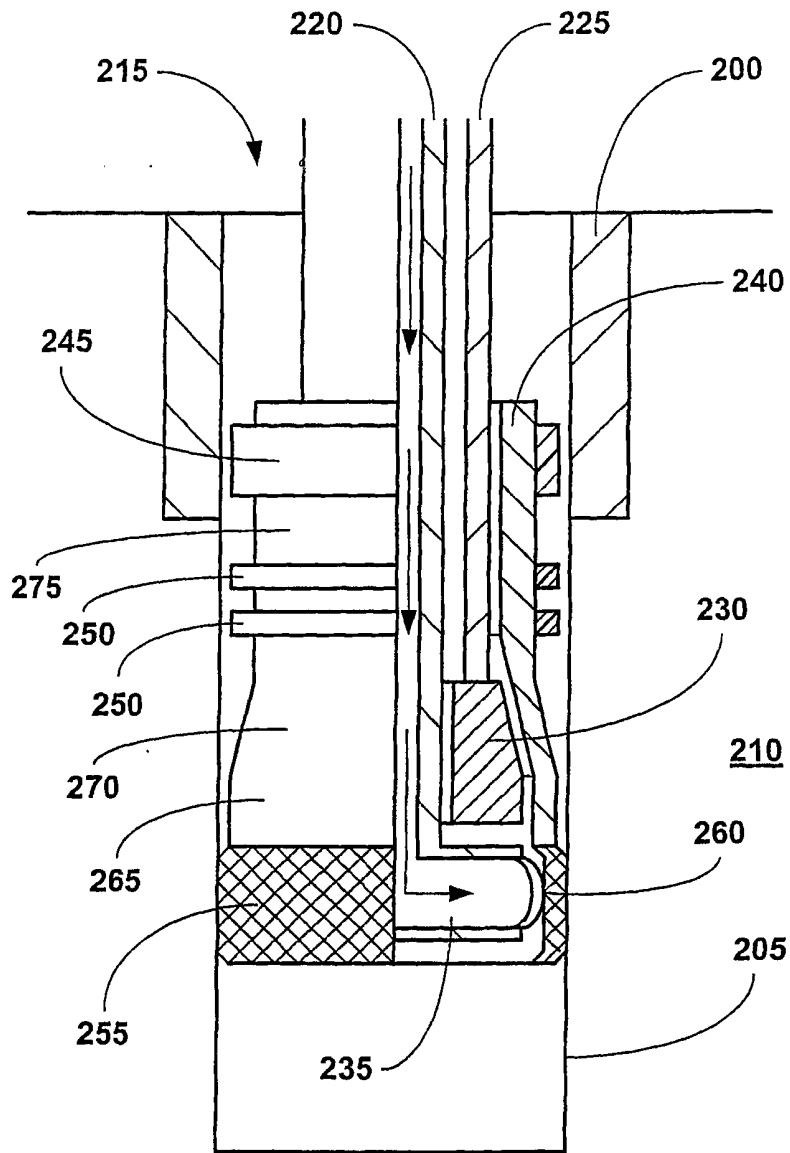

FIGURE 2b

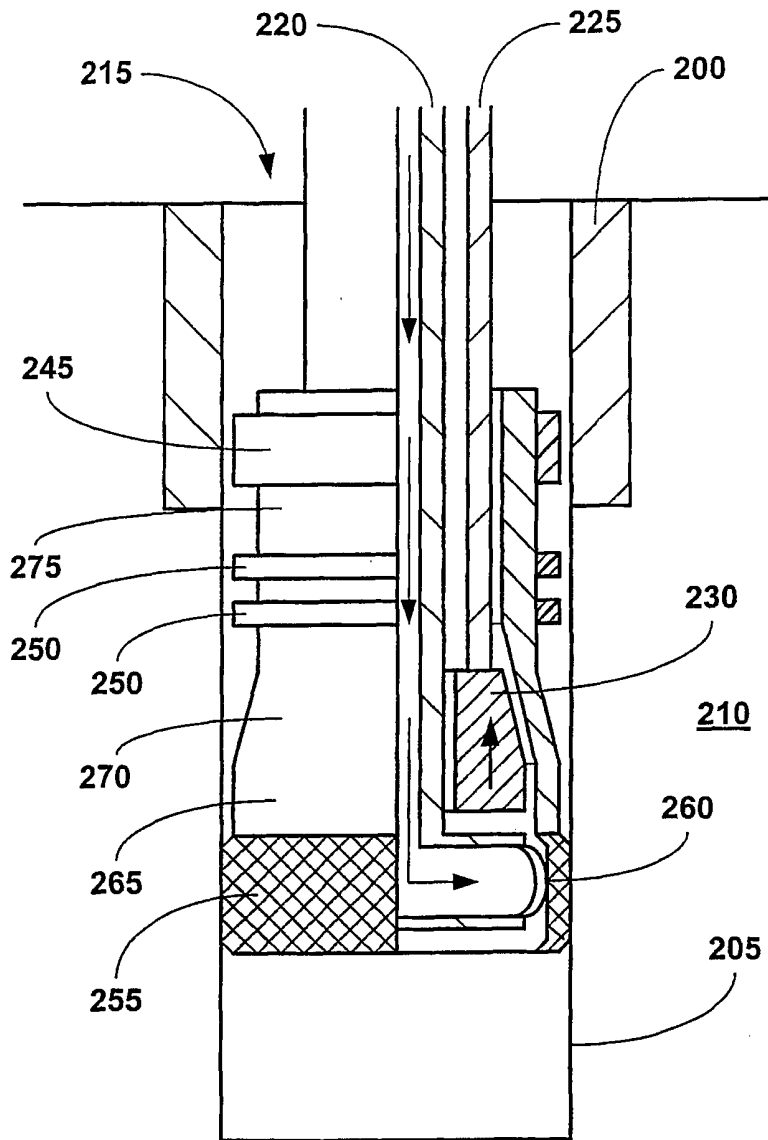

FIGURE 2c

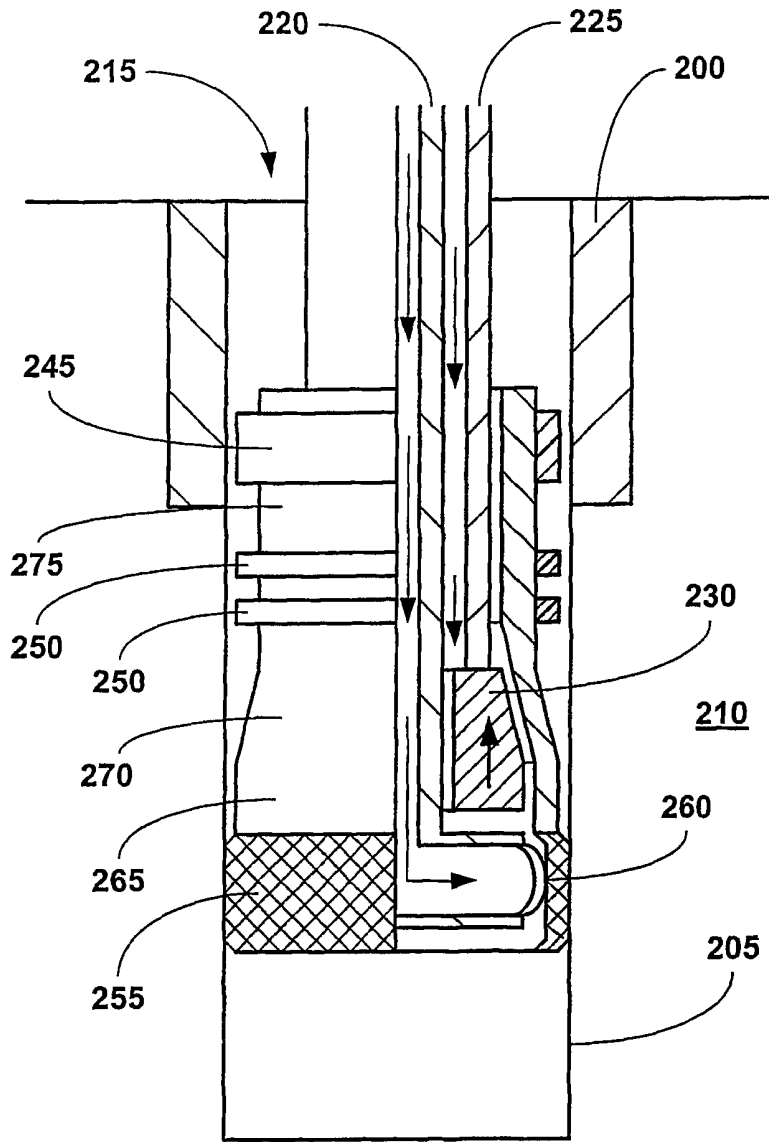

FIGURE 2d

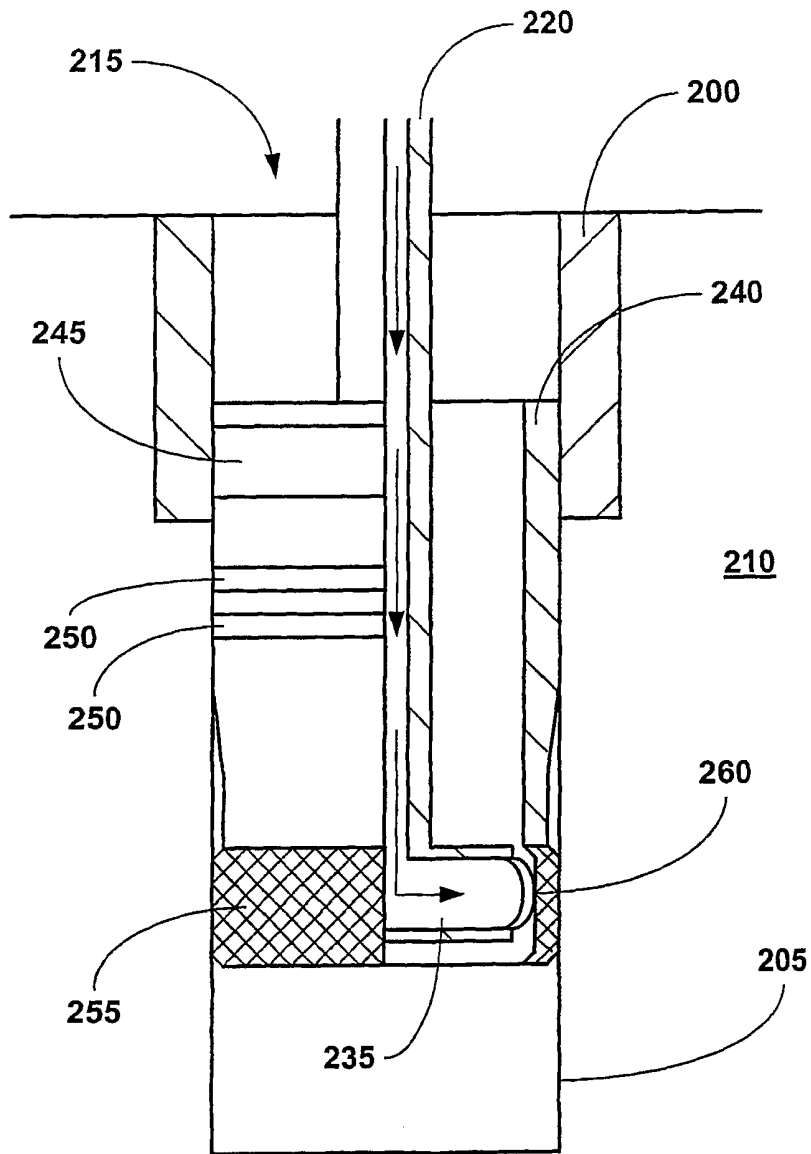

FIGURE 2e

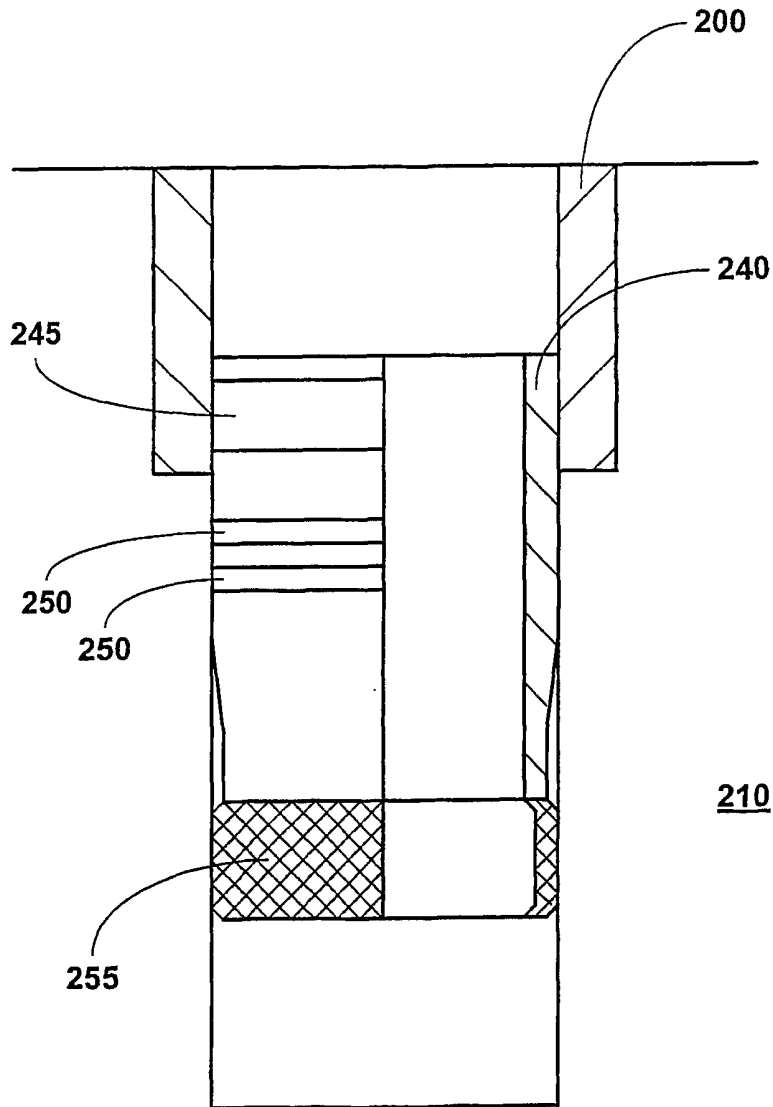

FIGURE 2f

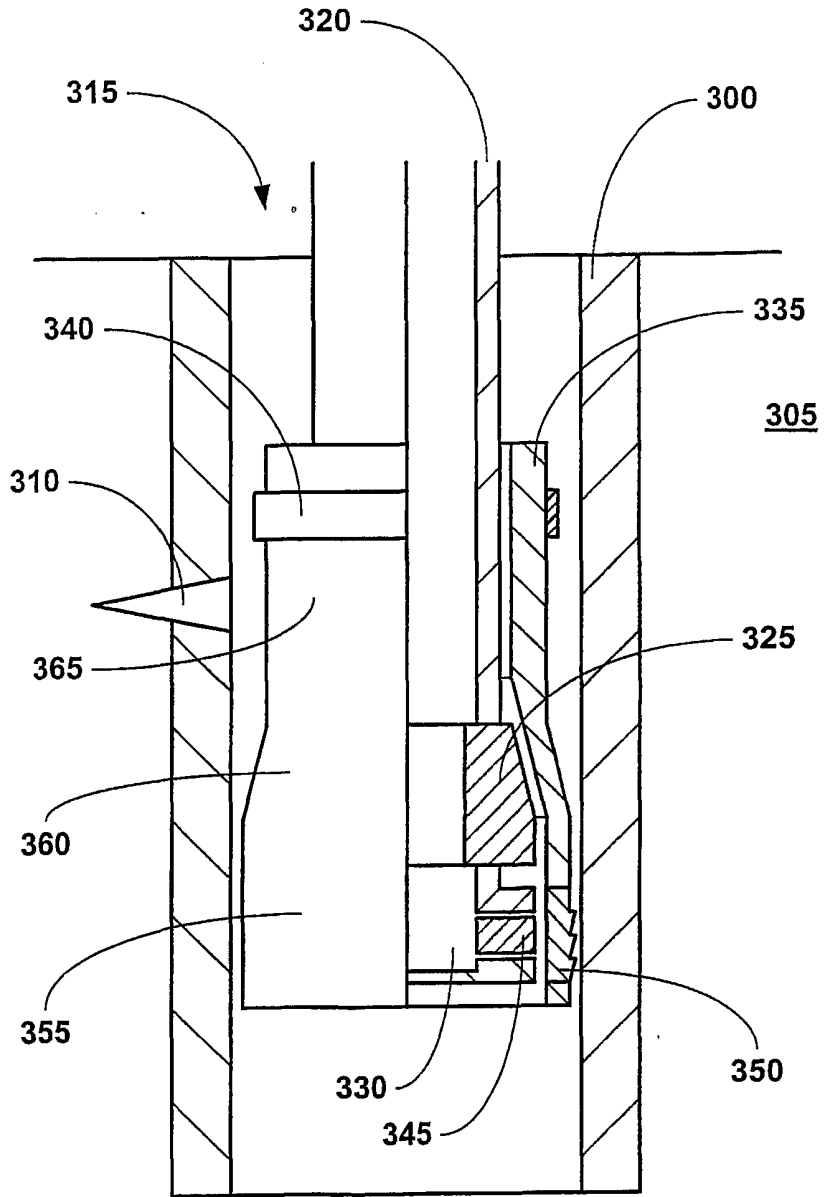

FIGURE 3a



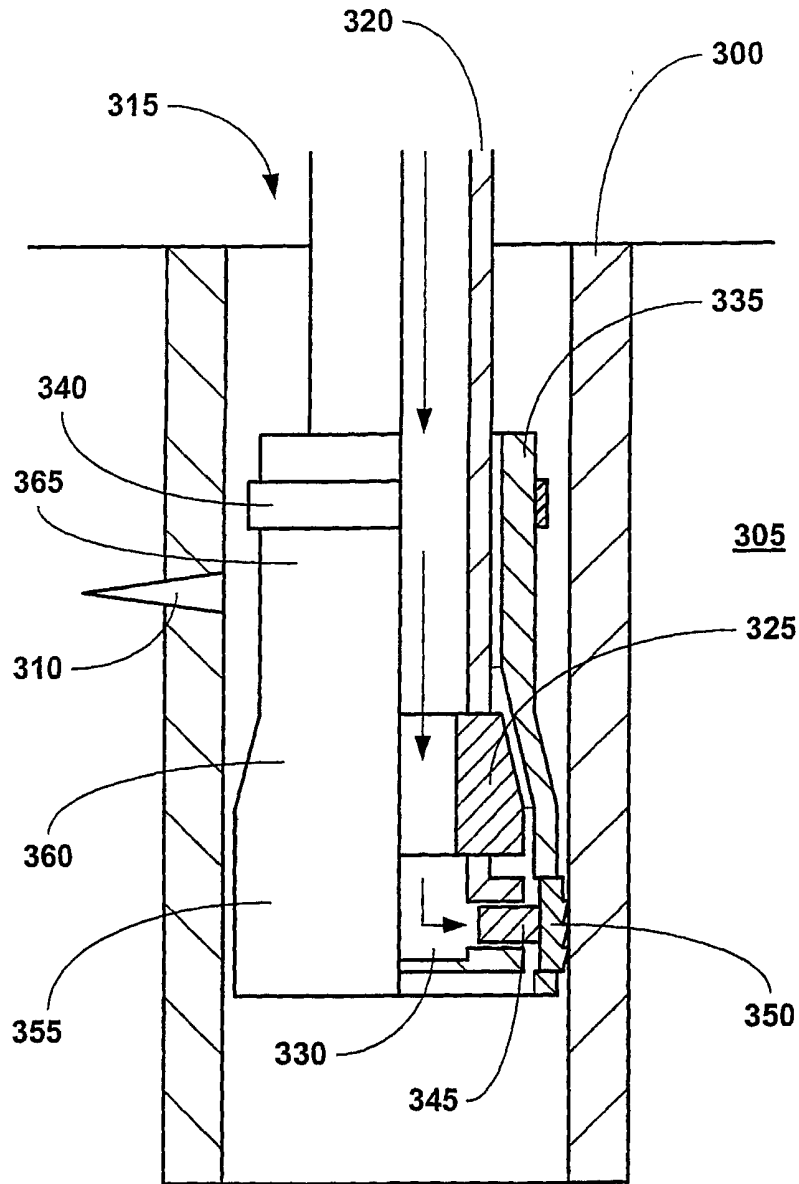

FIGURE 3b

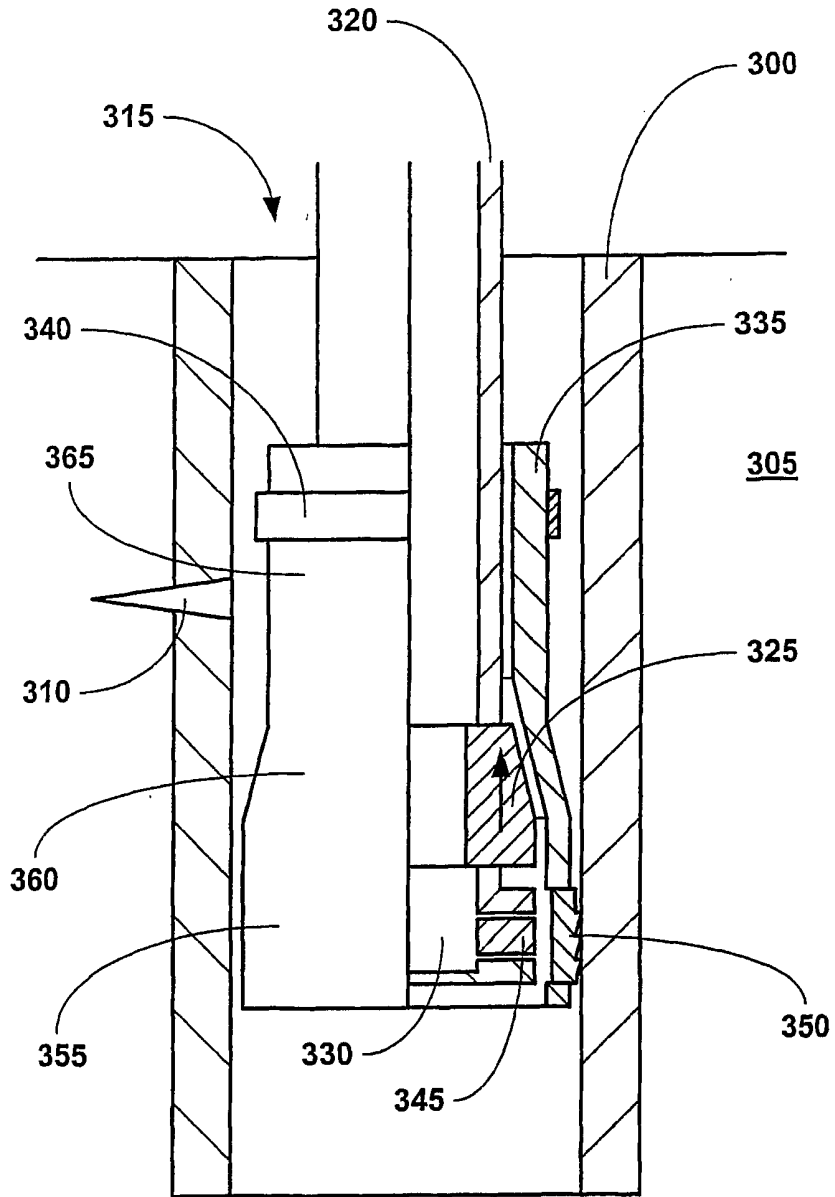

FIGURE 3c

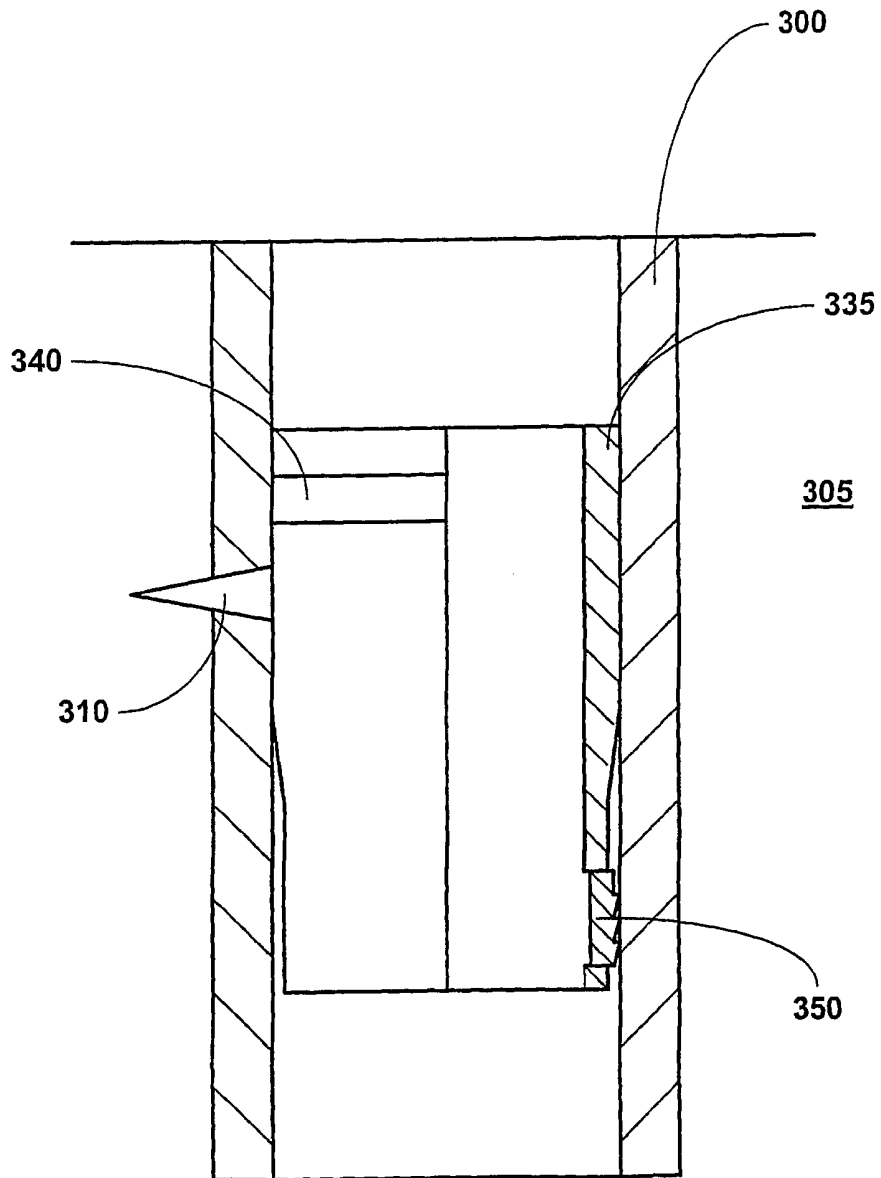

FIGURE 3d

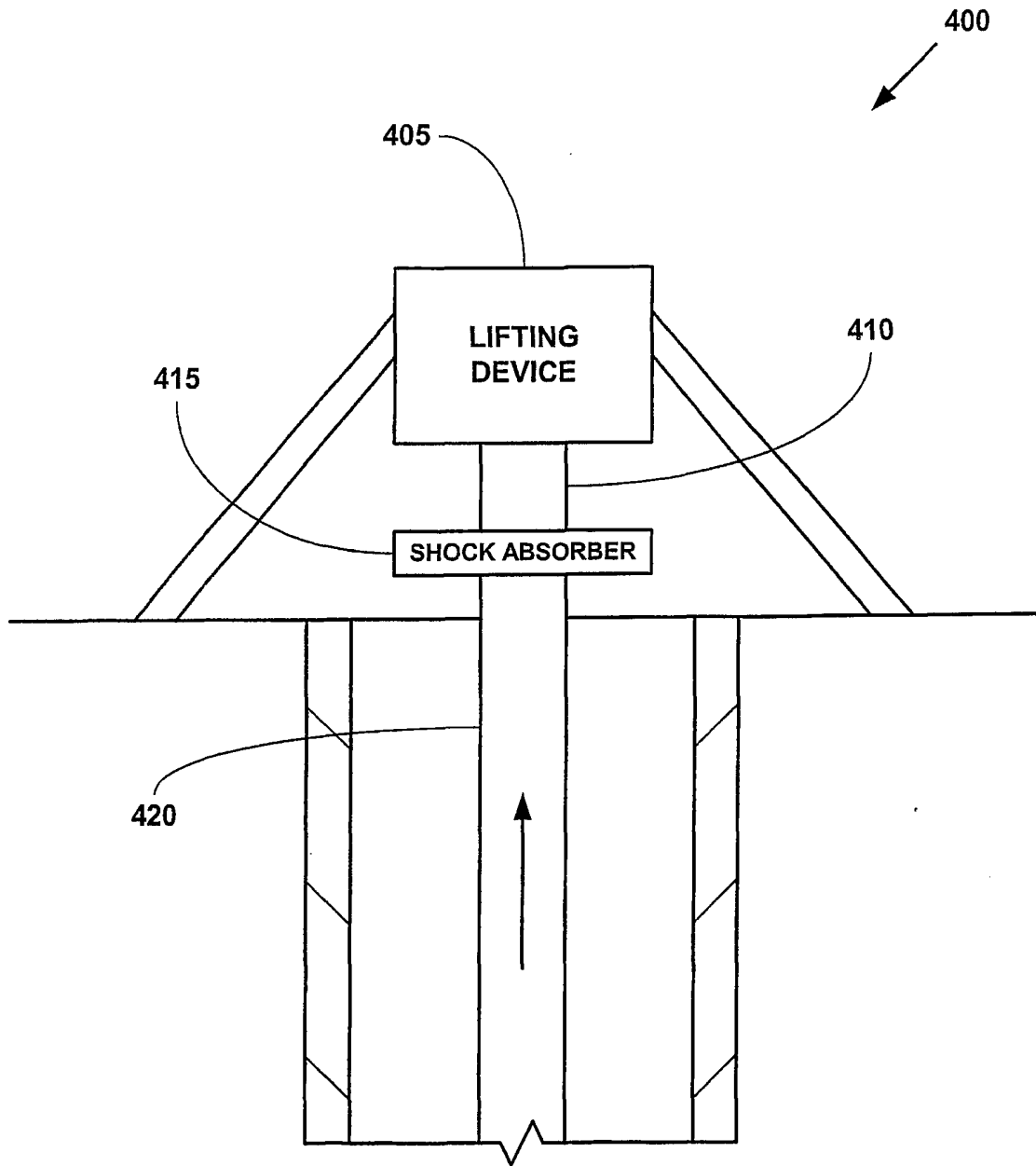

FIGURE 4

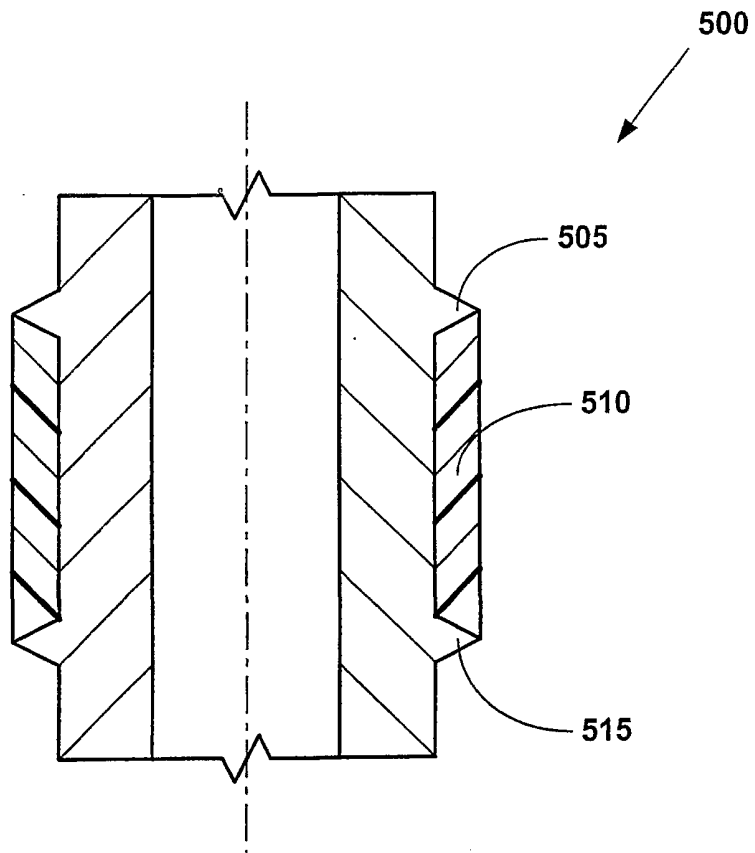

FIGURE 5

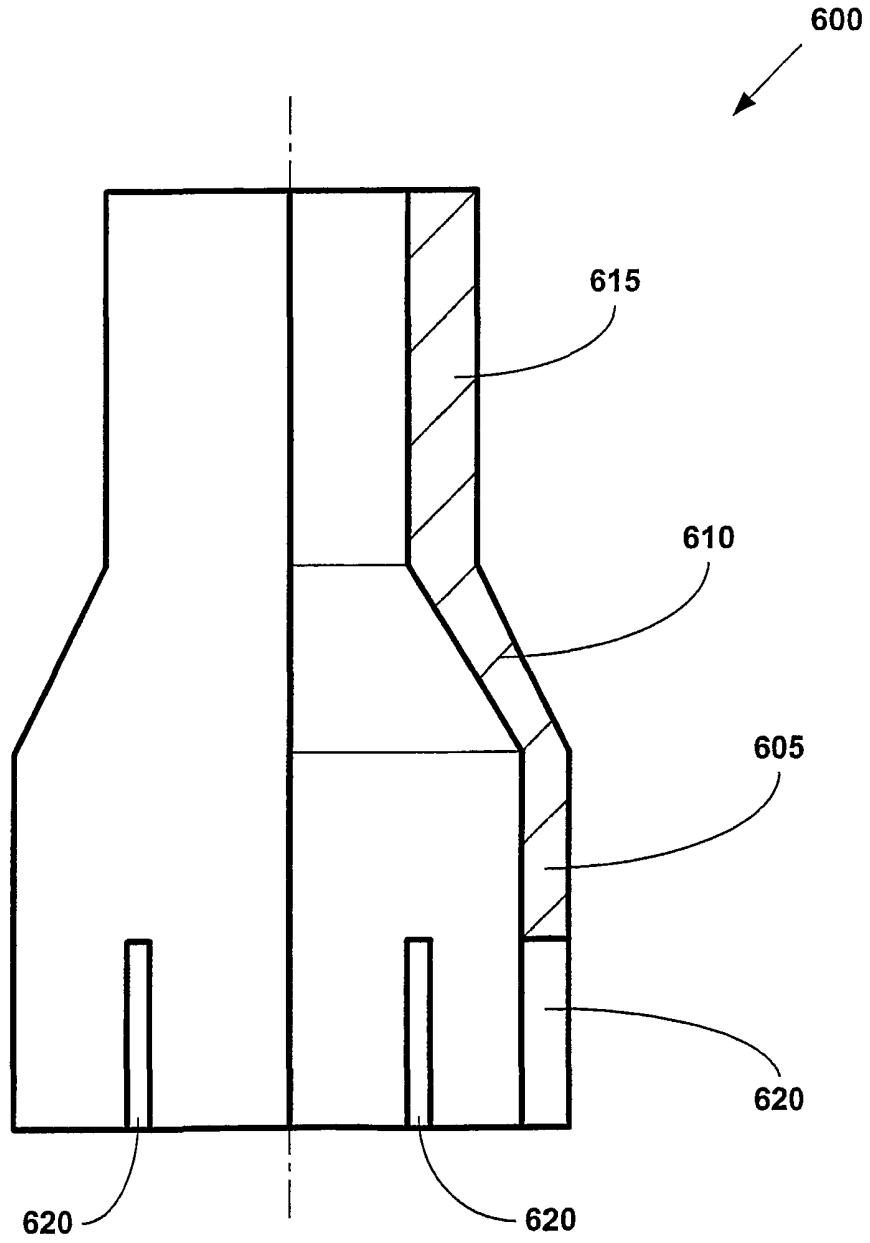

FIGURE 6

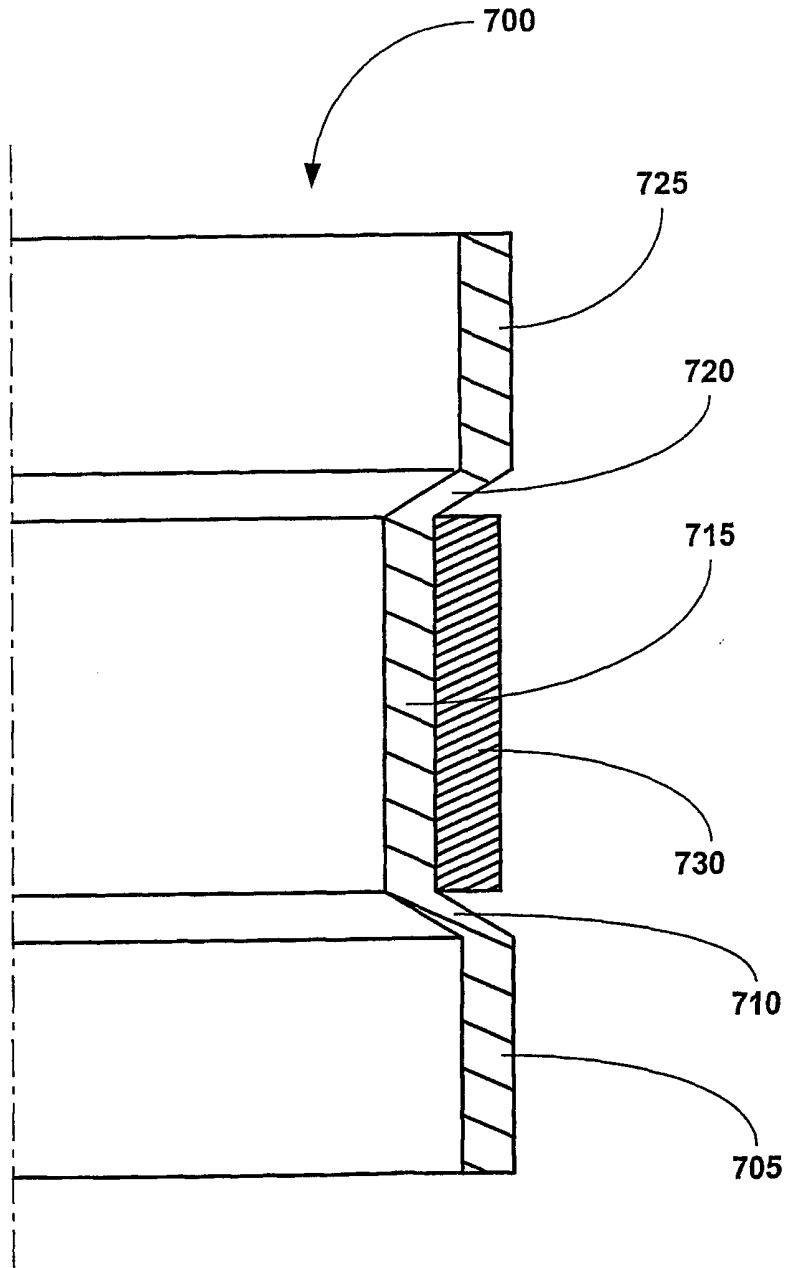

FIGURE 7

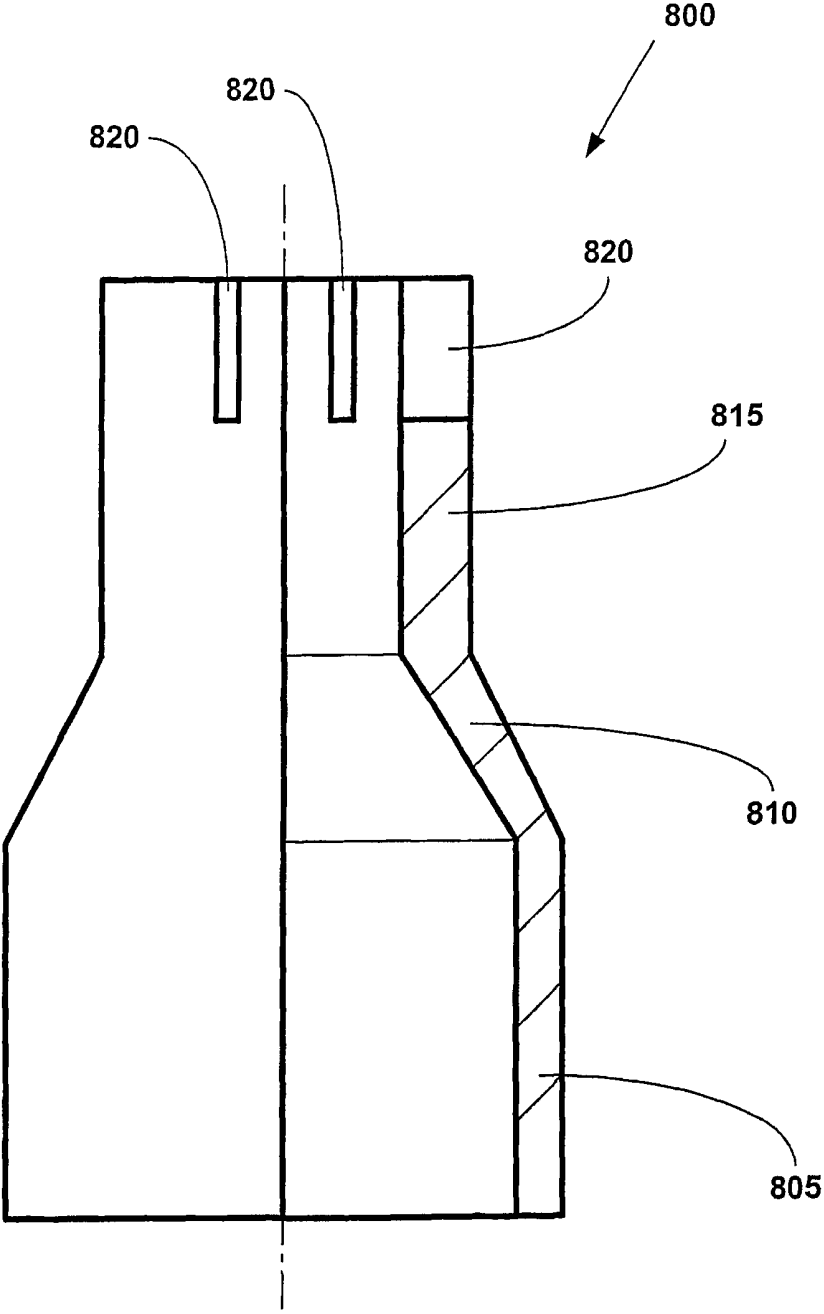

FIGURE 8



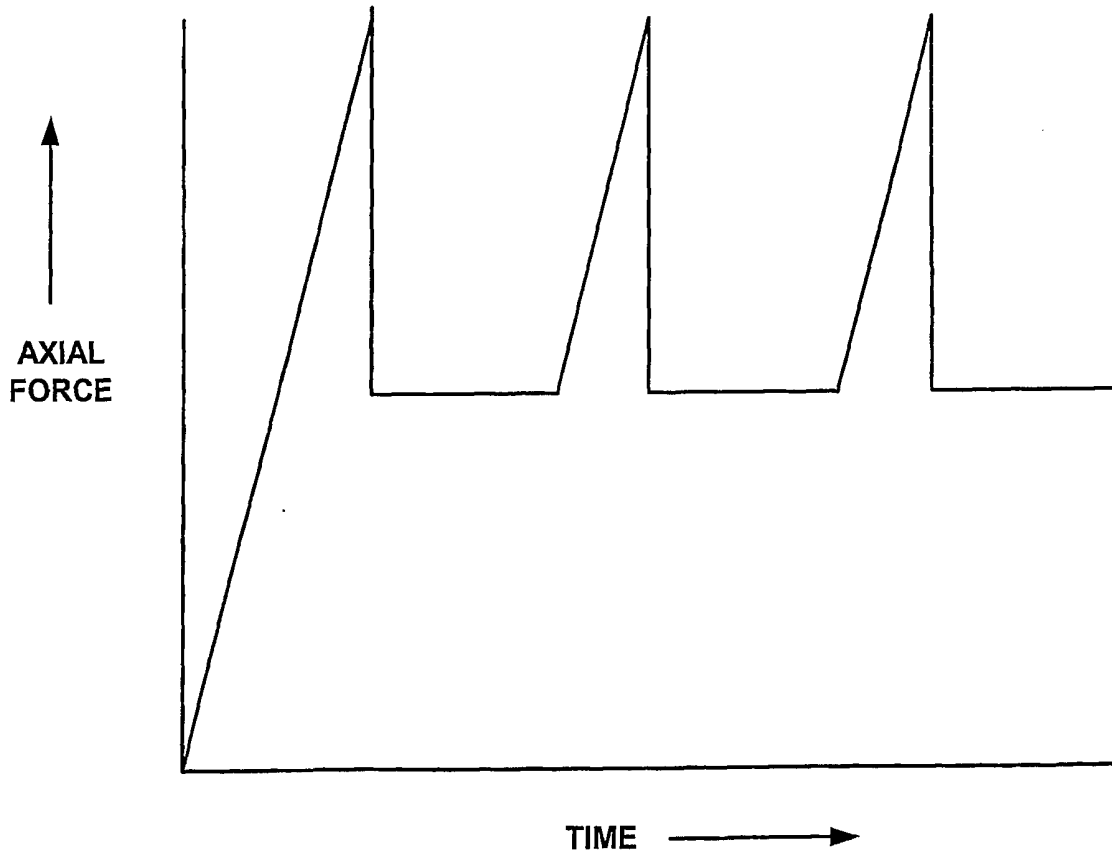

FIGURE 9

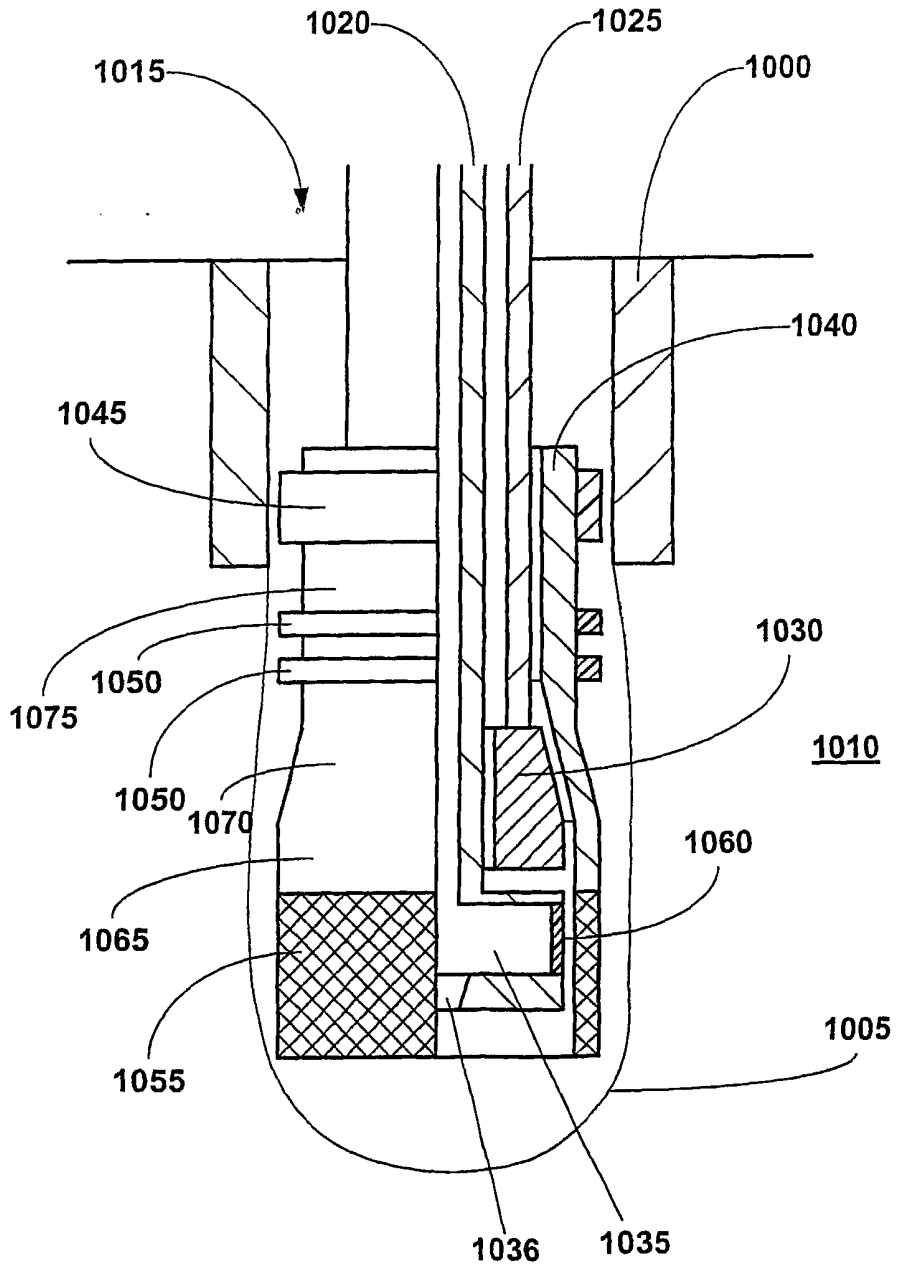

FIGURE 10a

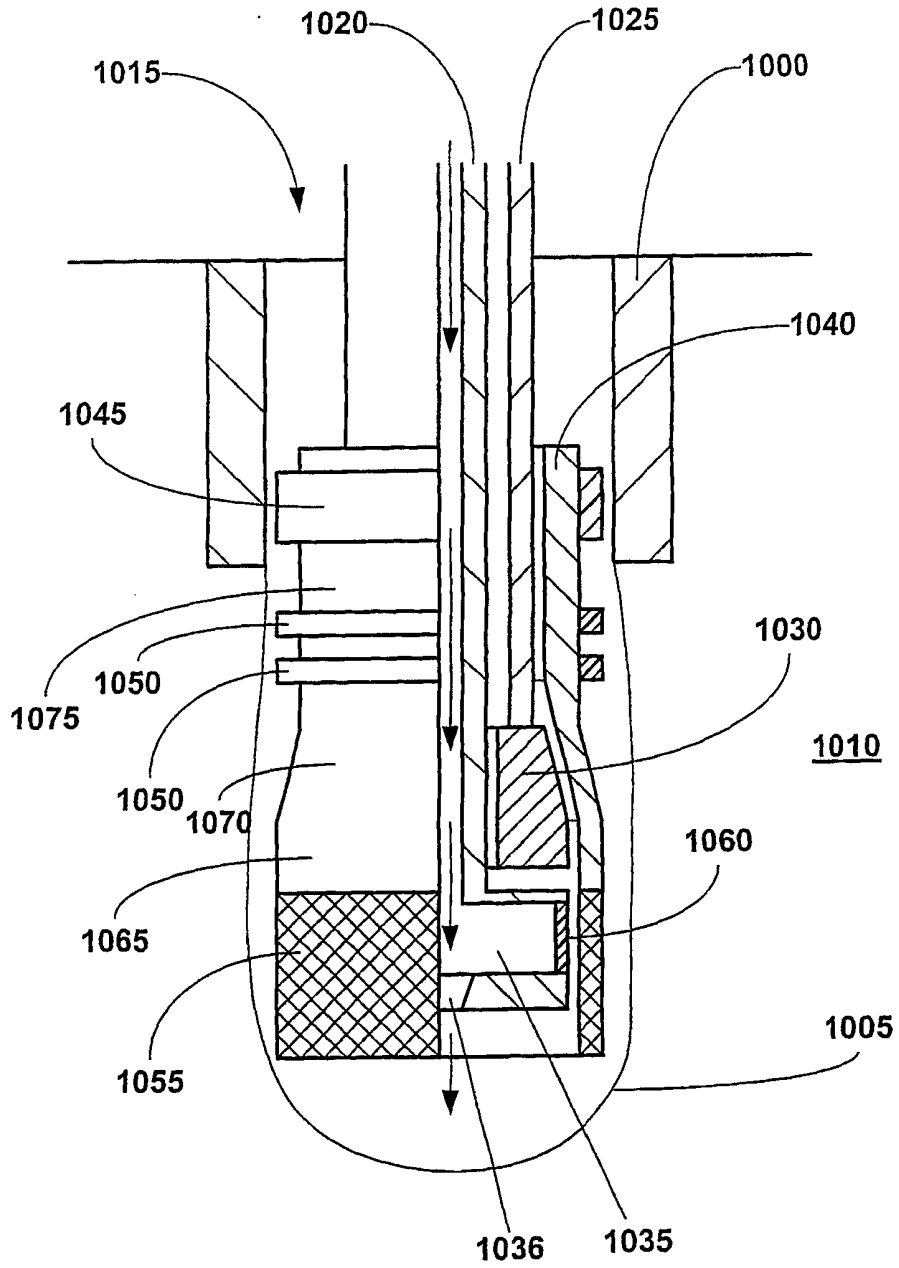

FIGURE 10b

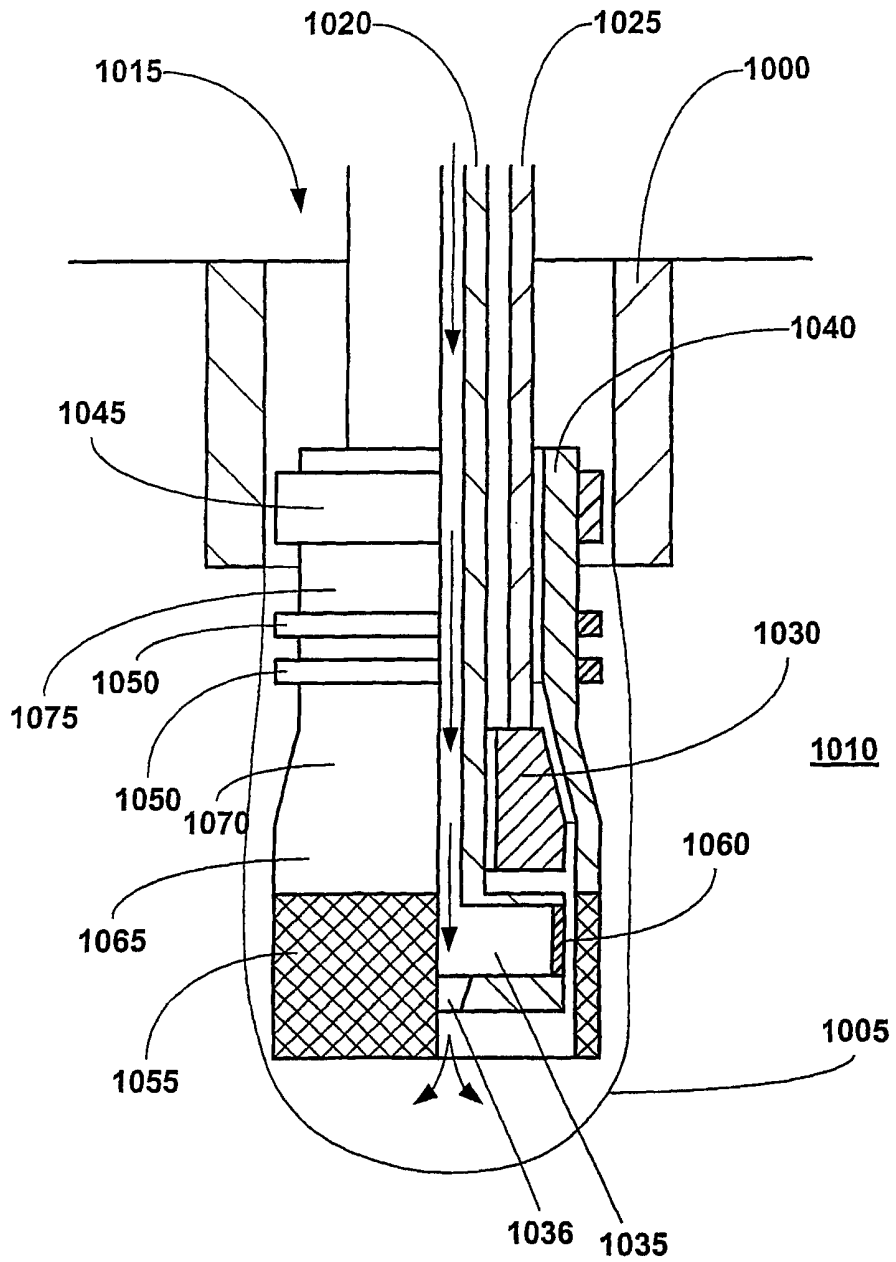

FIGURE 10c

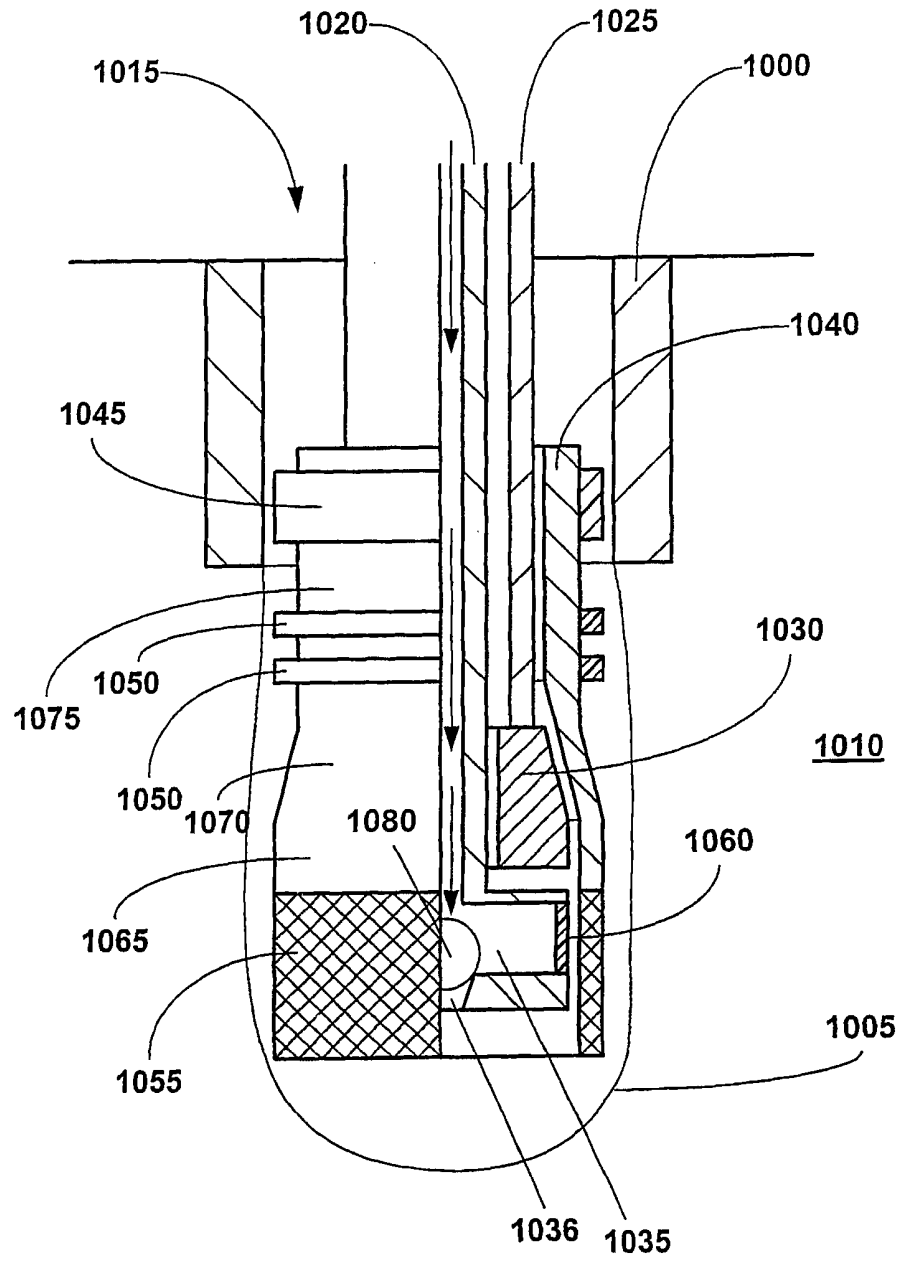

FIGURE 10d

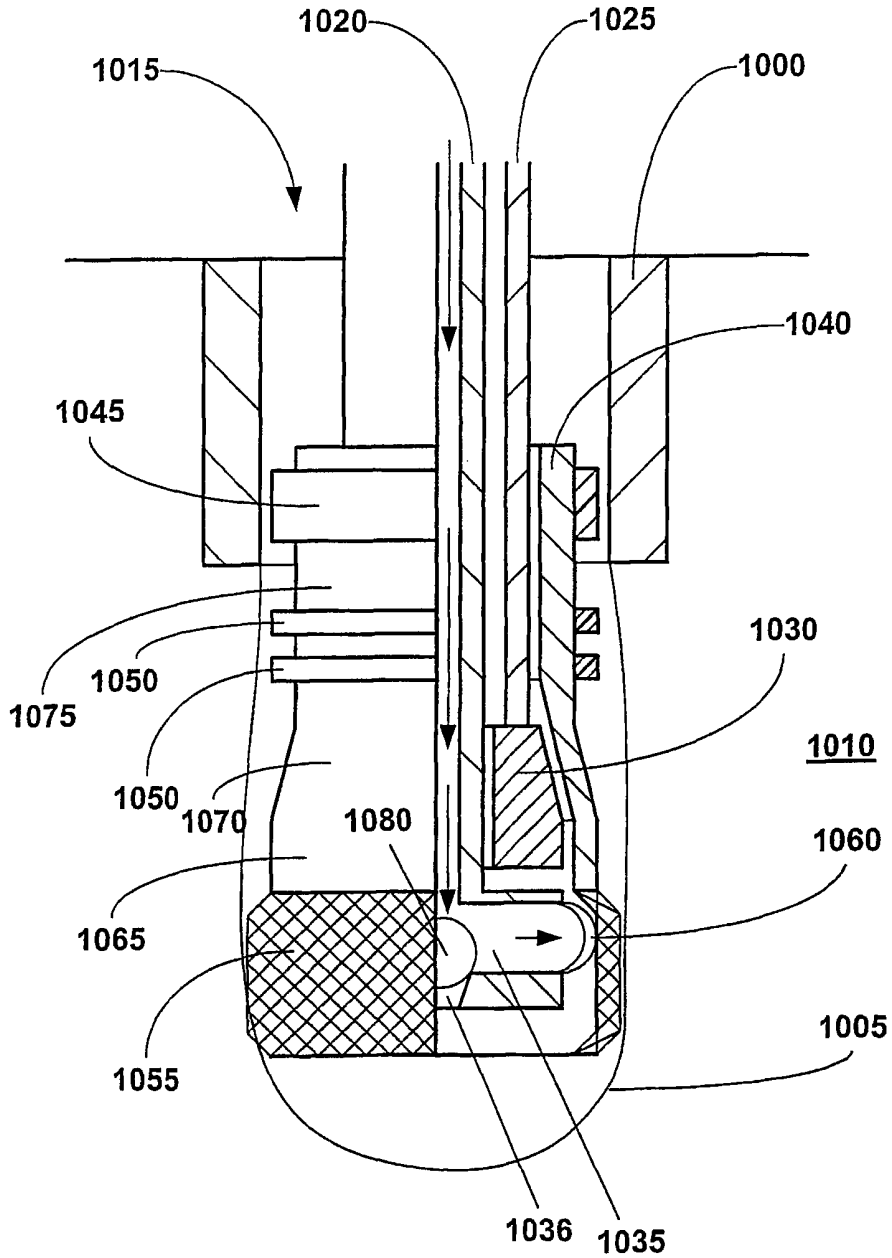

FIGURE 10e

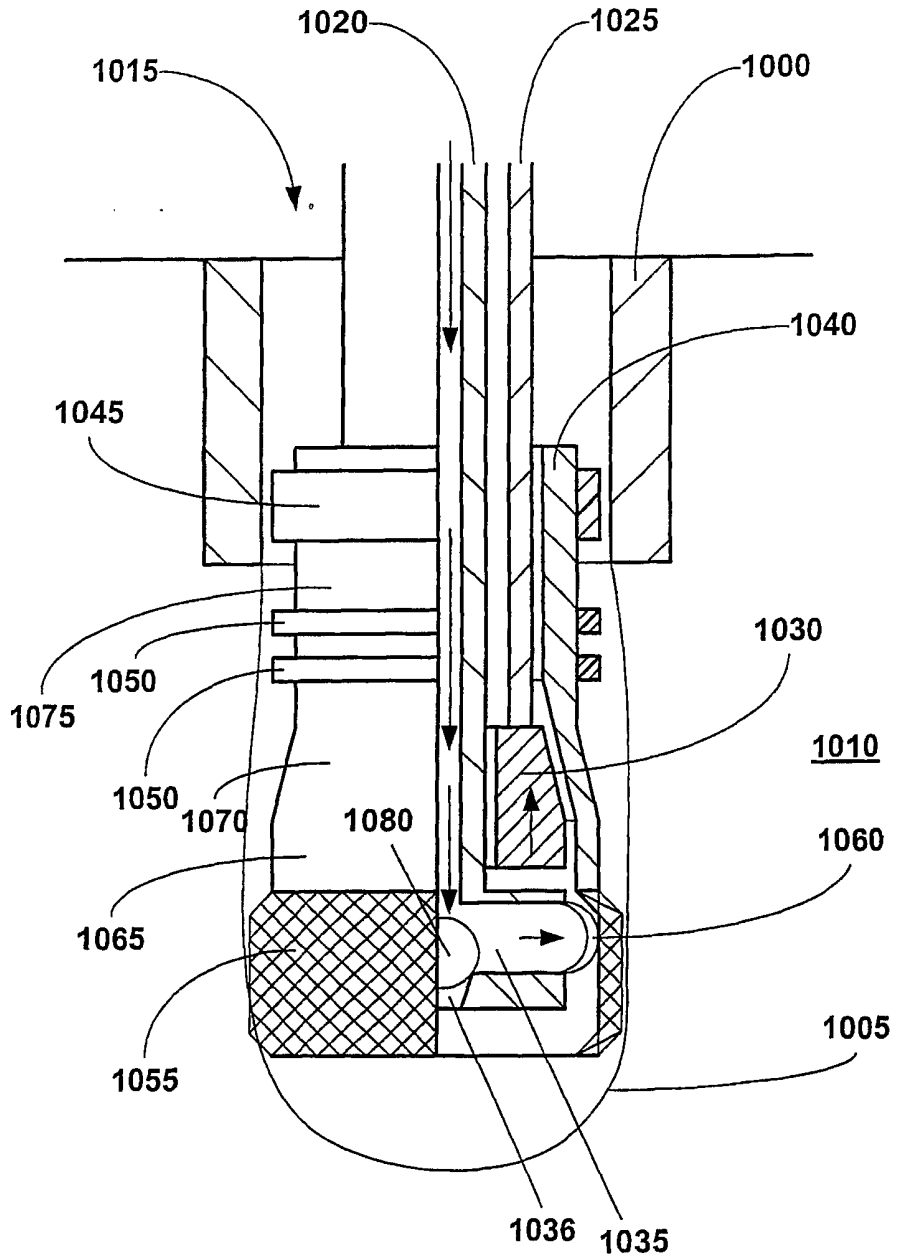

FIGURE 10f

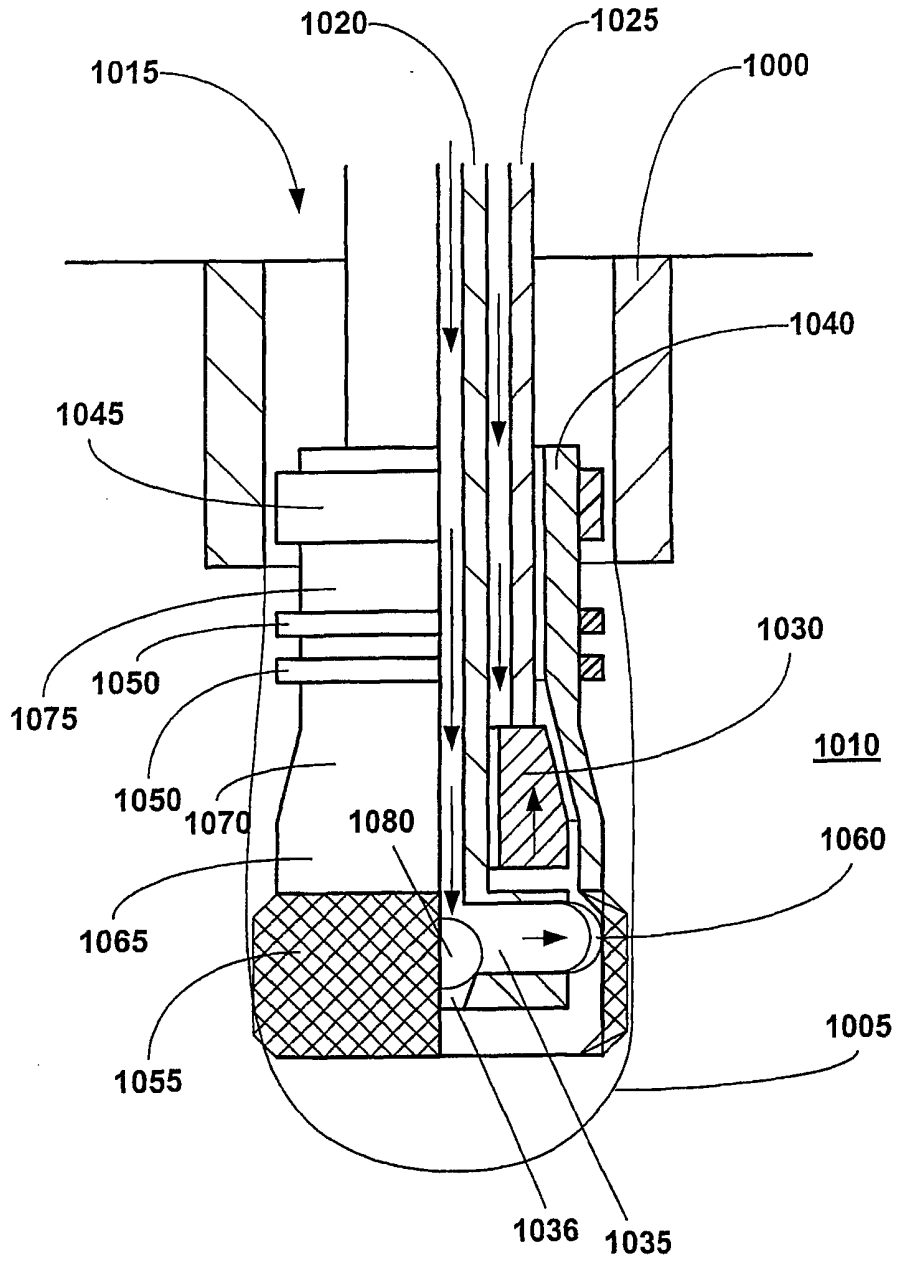

FIGURE 10g



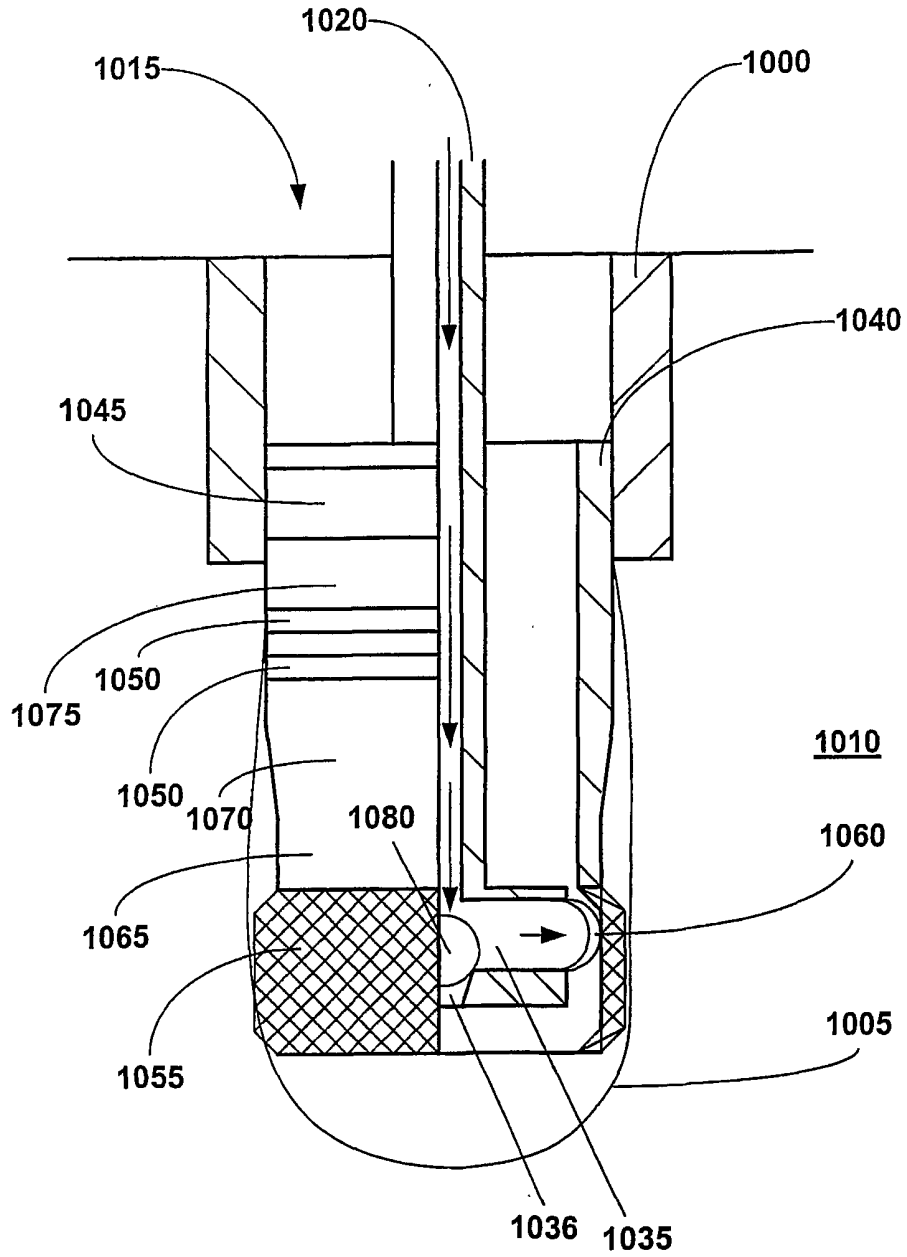

FIGURE 10h

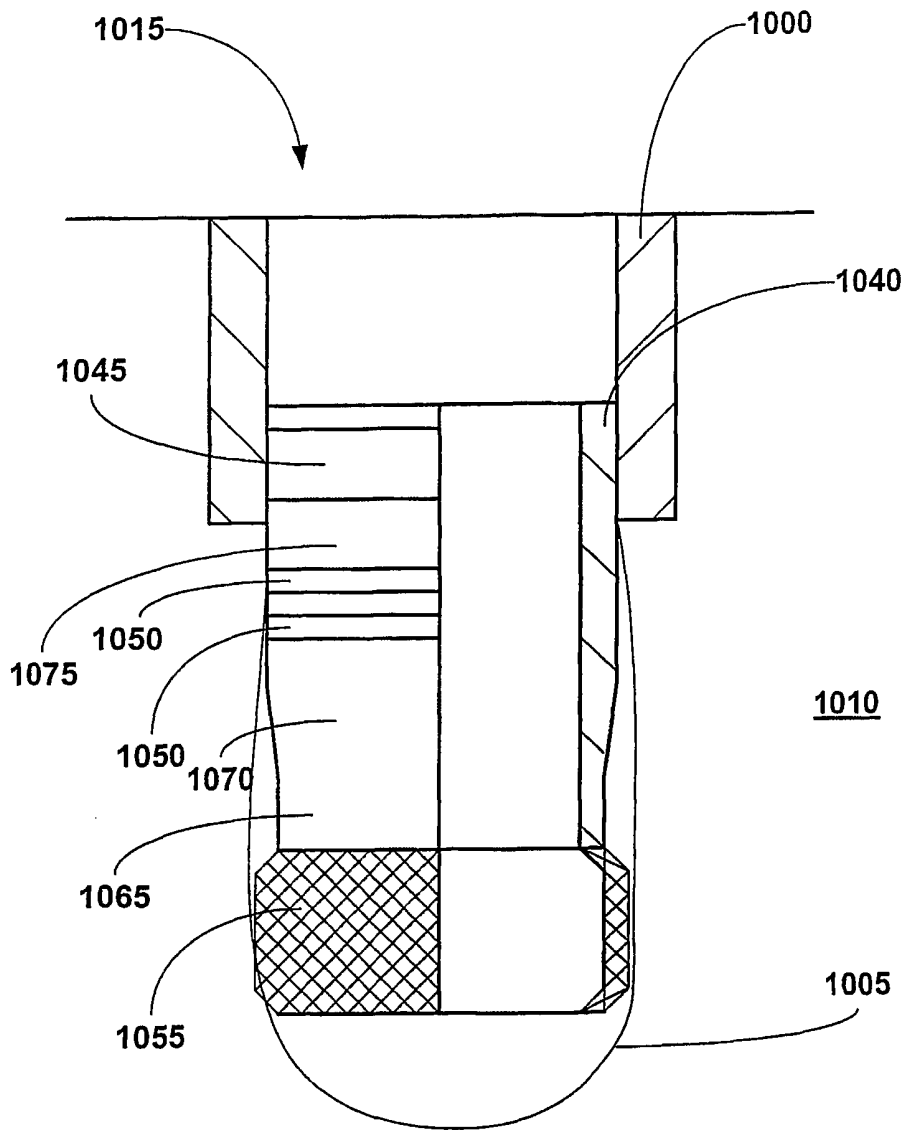

FIGURE 10i

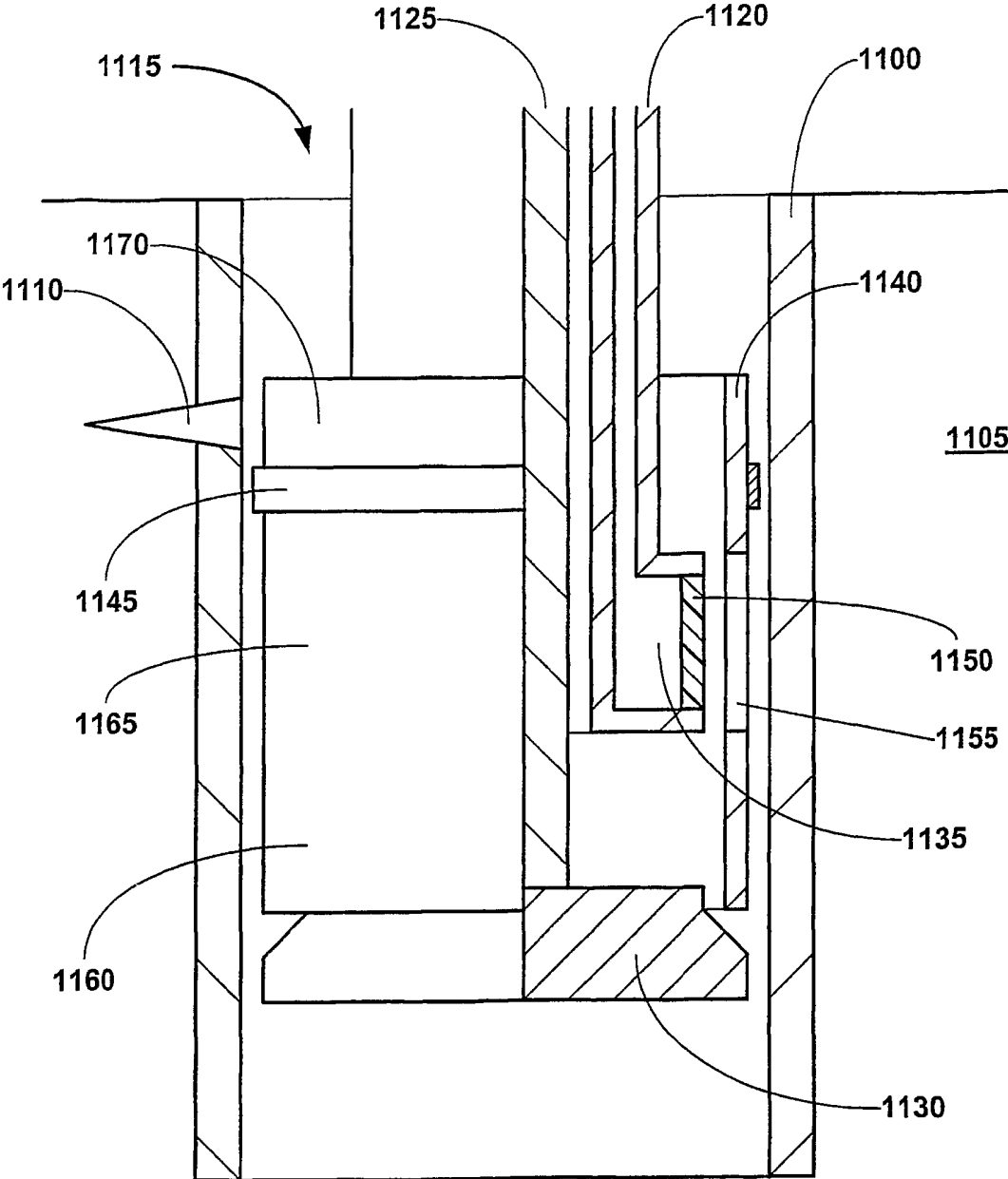

FIGURE 11a

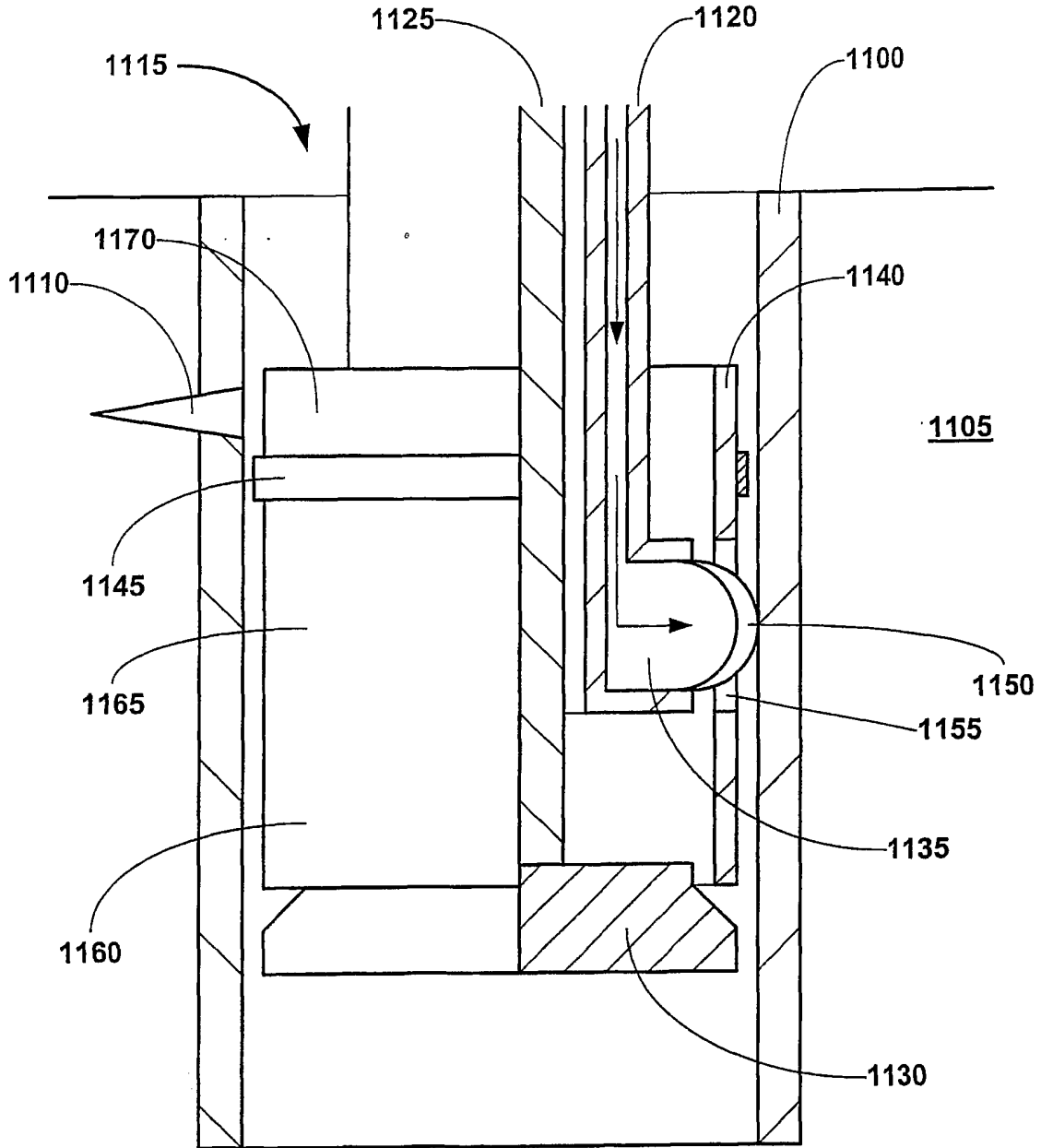

FIGURE 11b

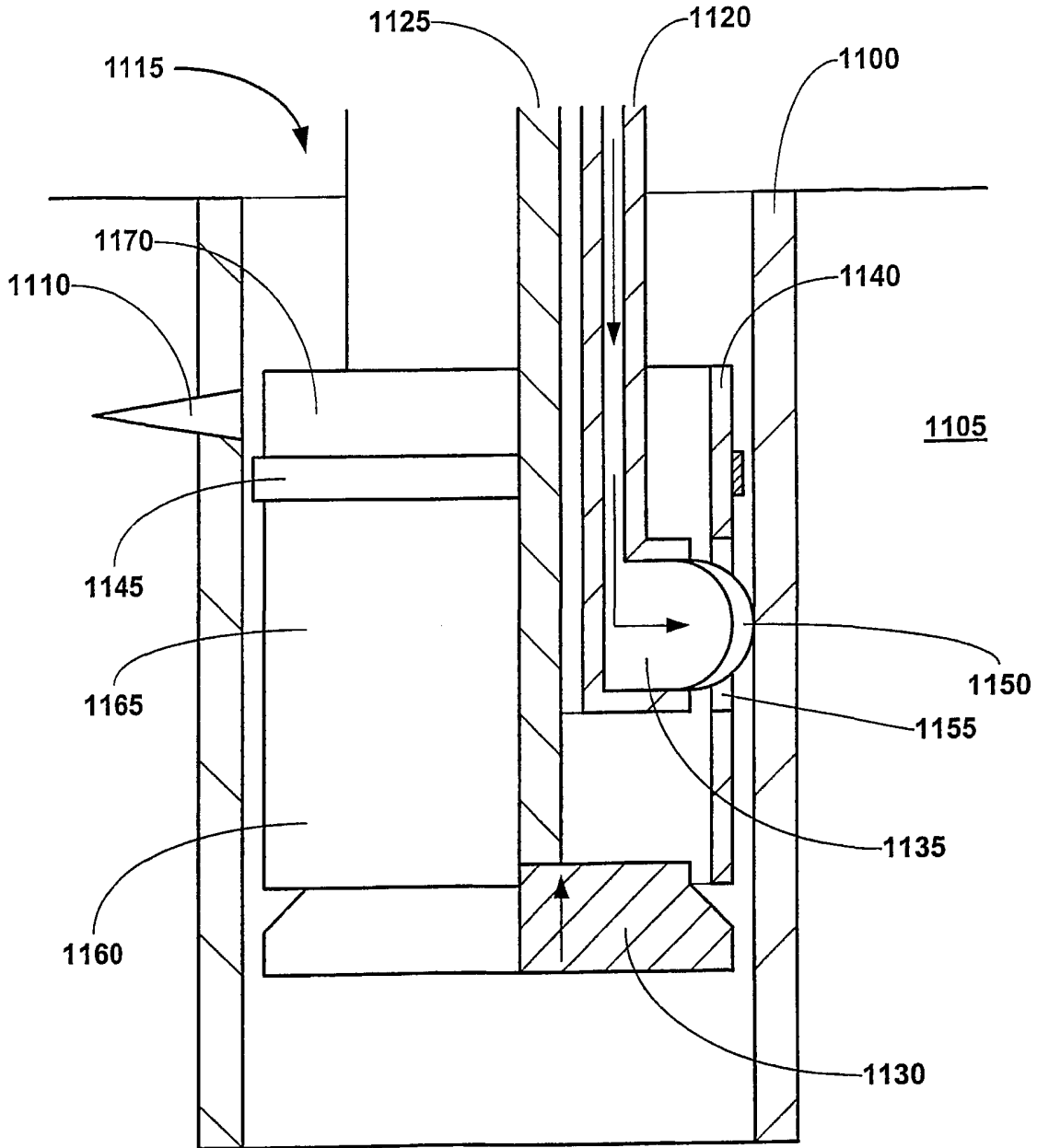

FIGURE 11c

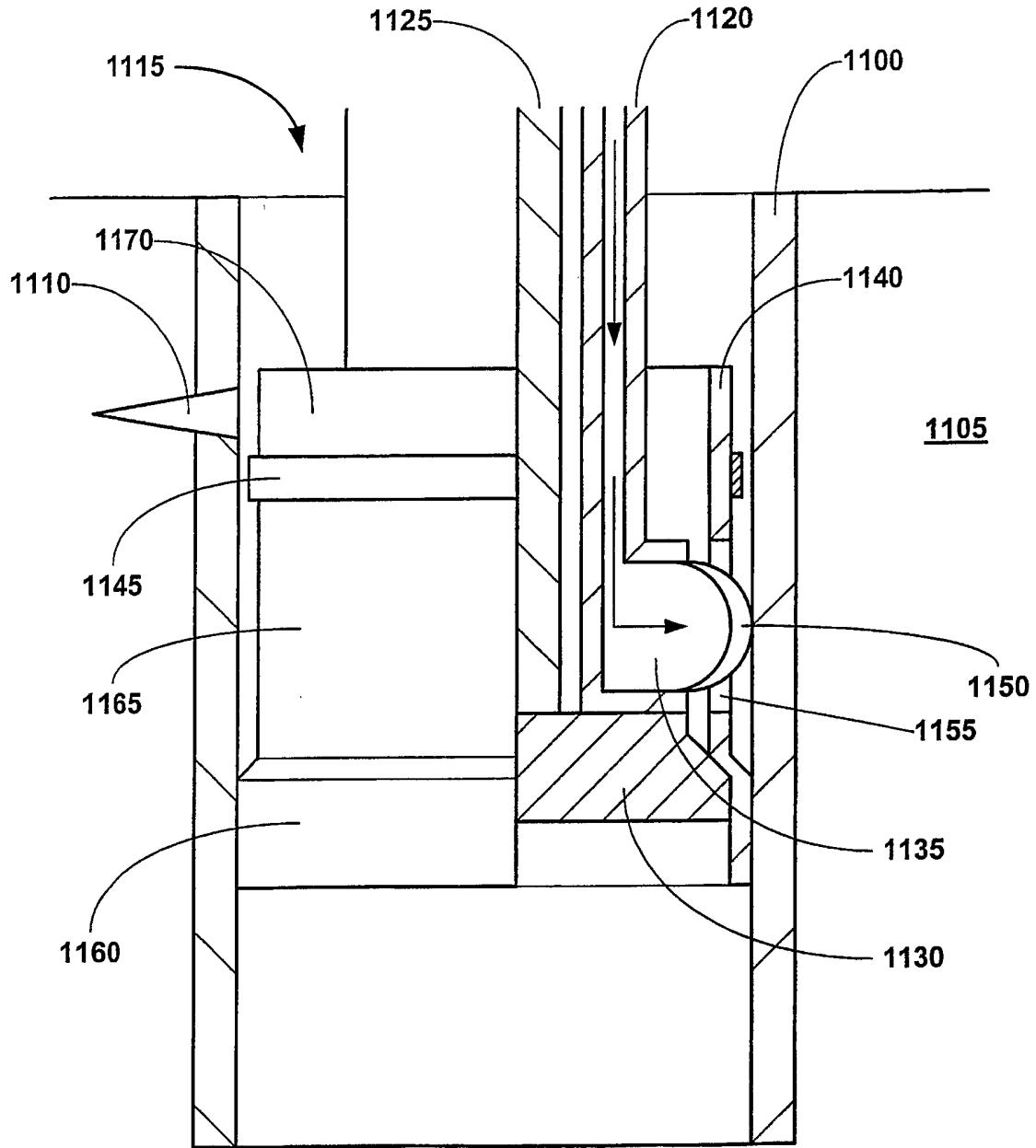

FIGURE 11d

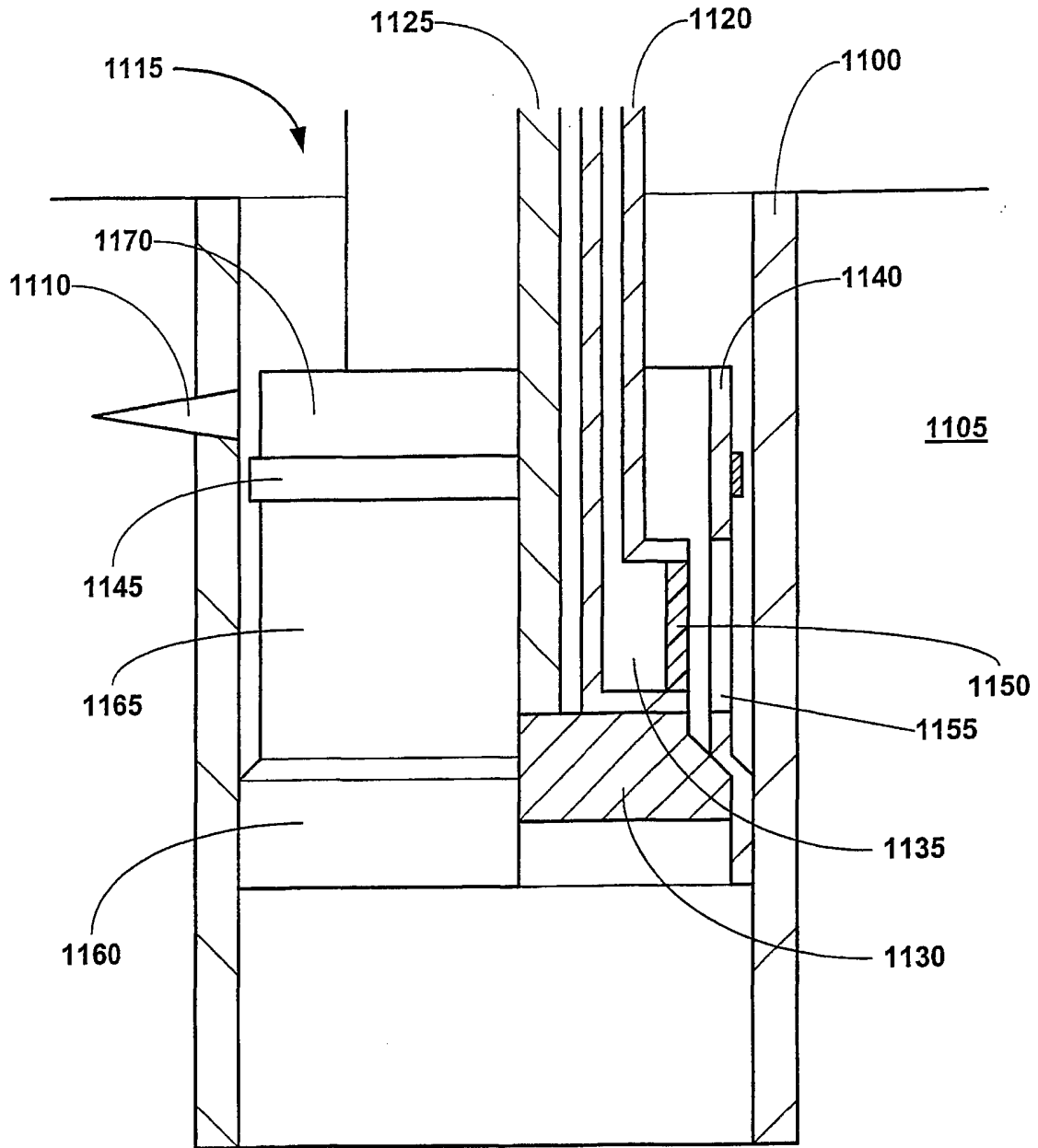

FIGURE 11e

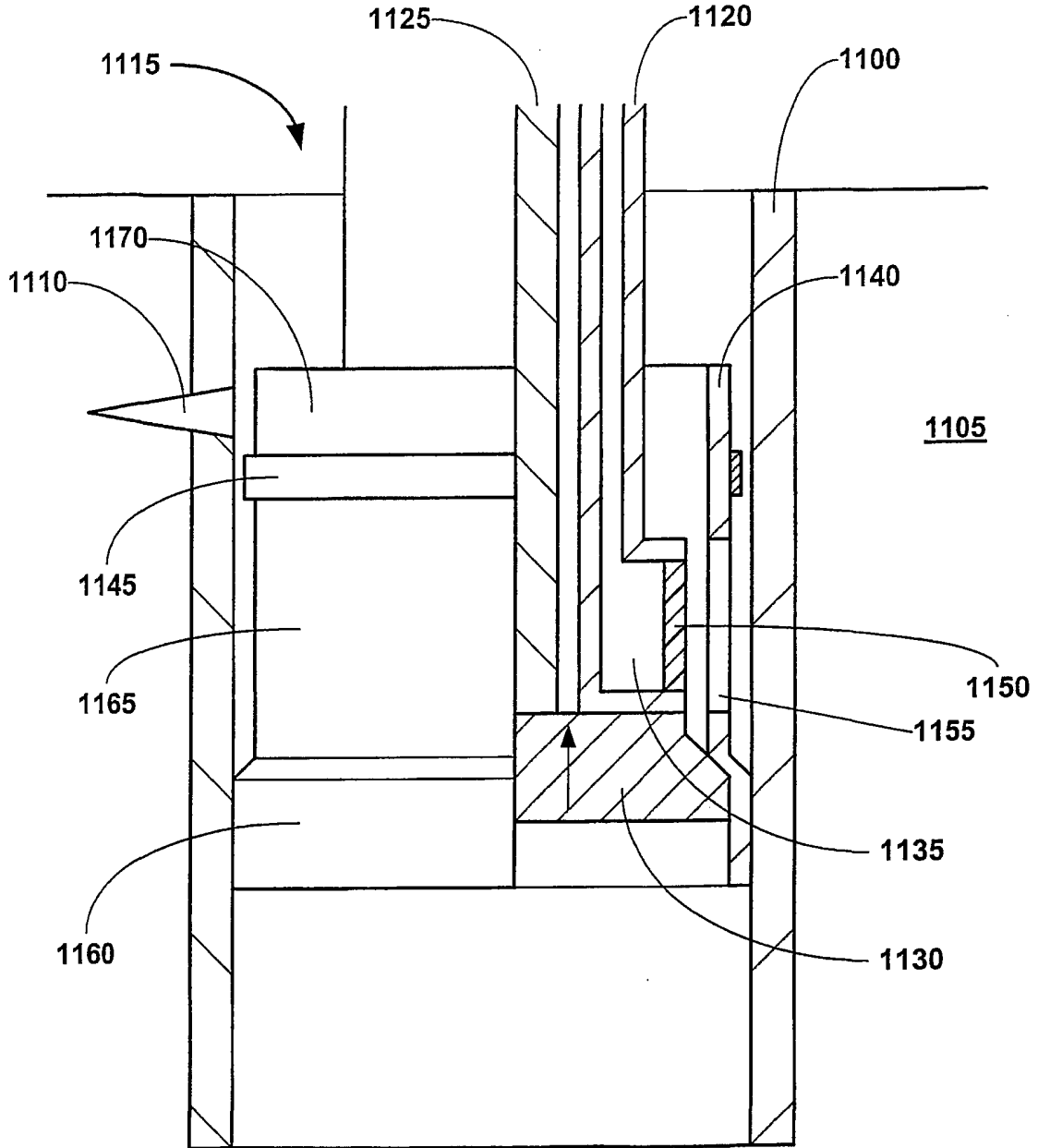

FIGURE 11f



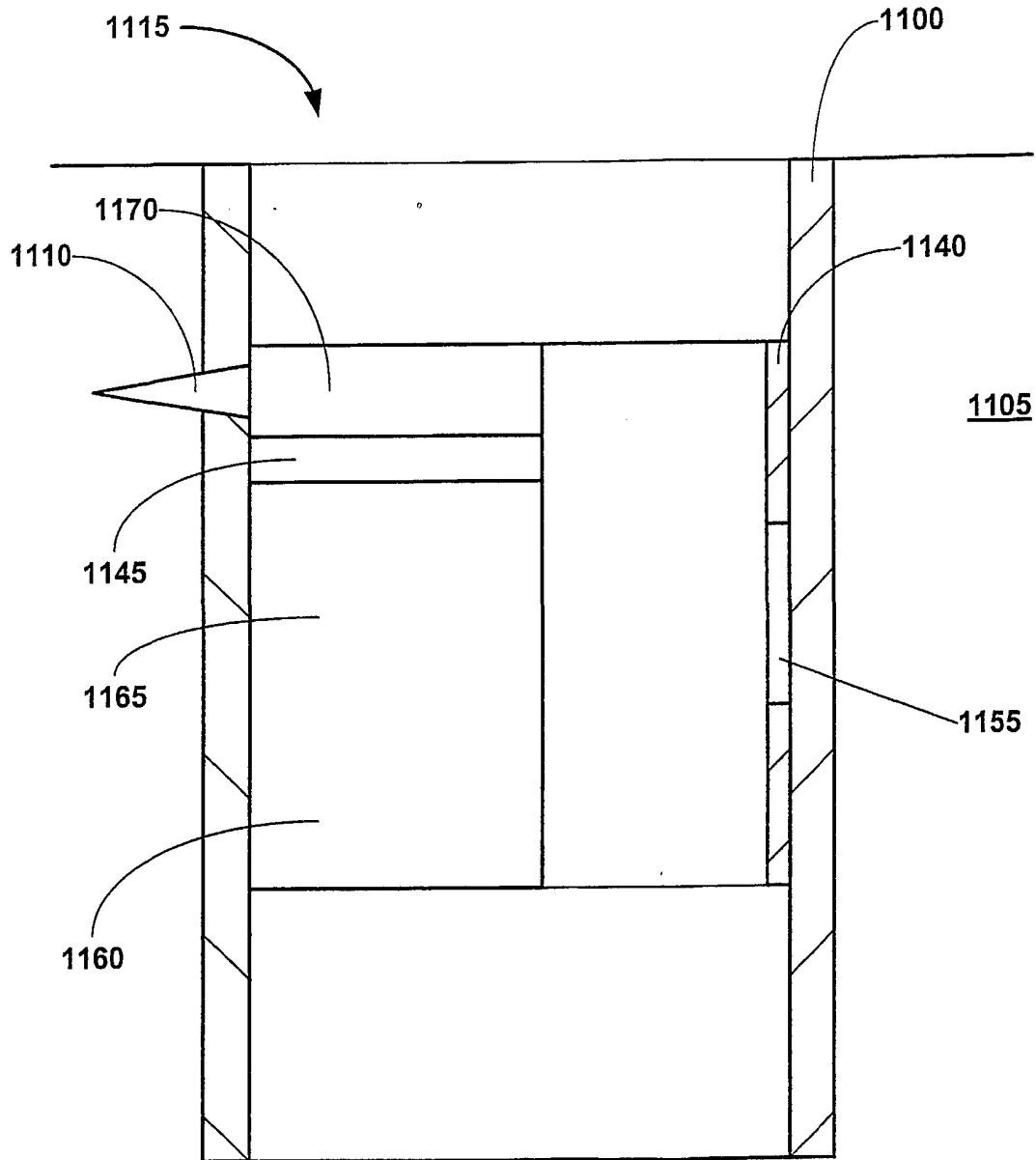

FIGURE 11g

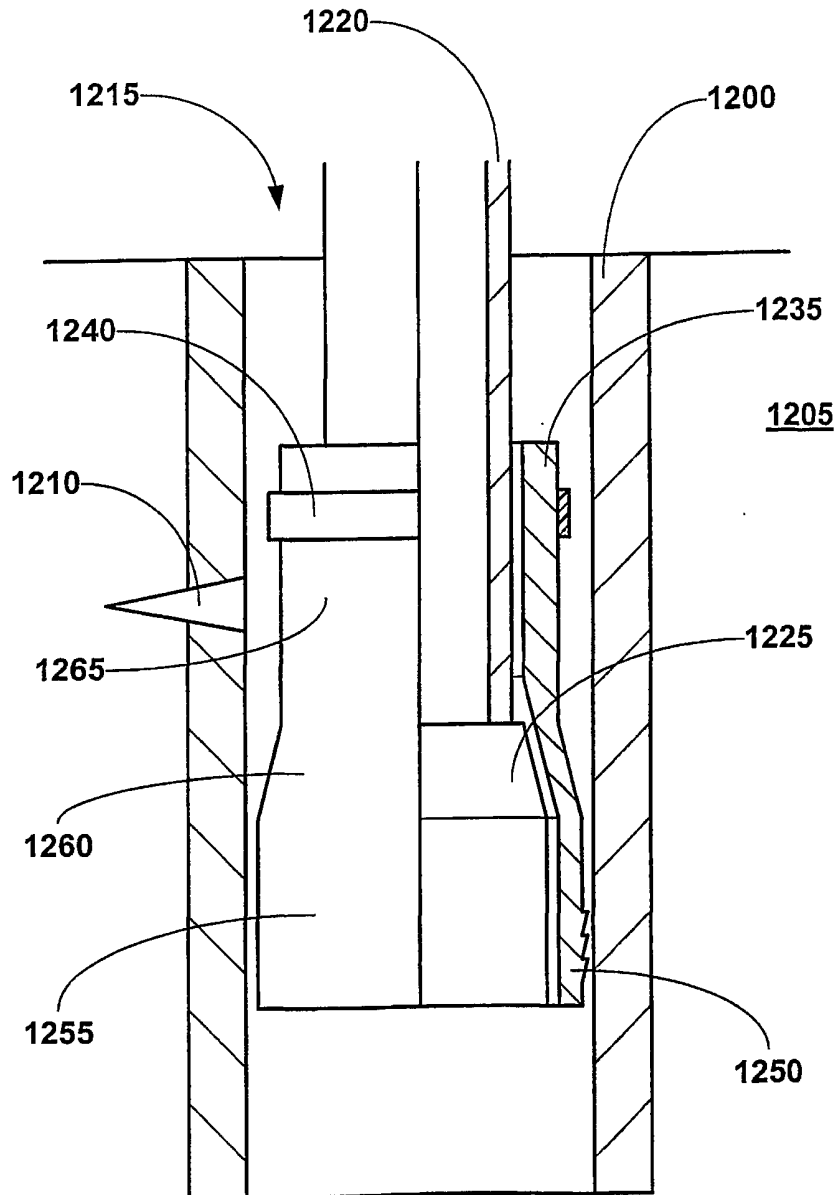

FIGURE 12a

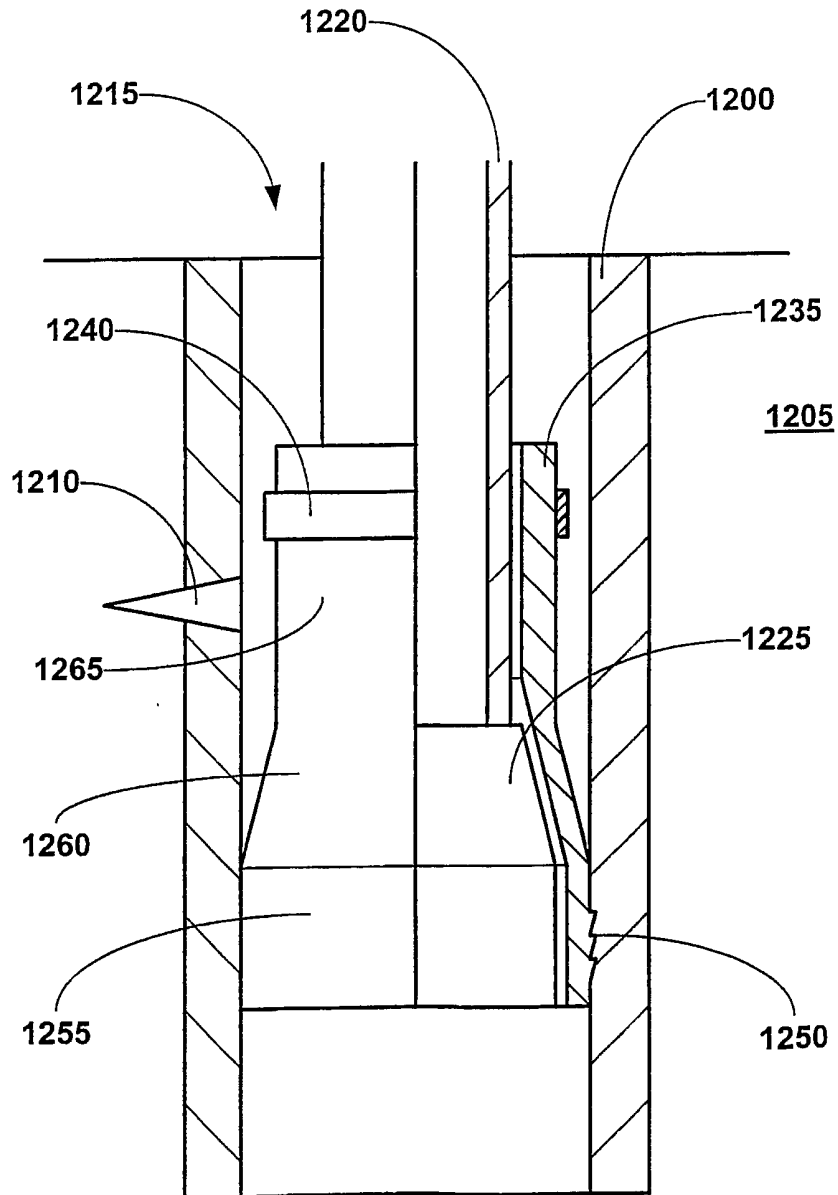

FIGURE 12b

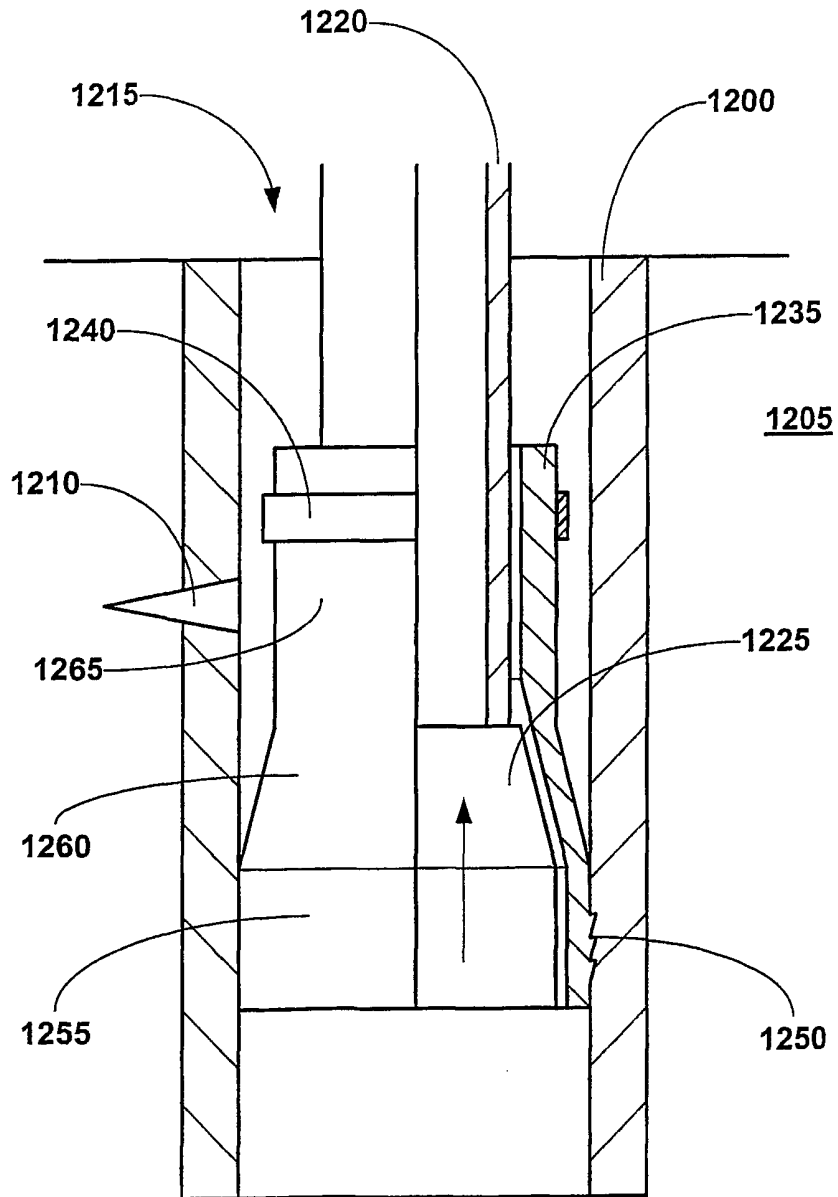

FIGURE 12c

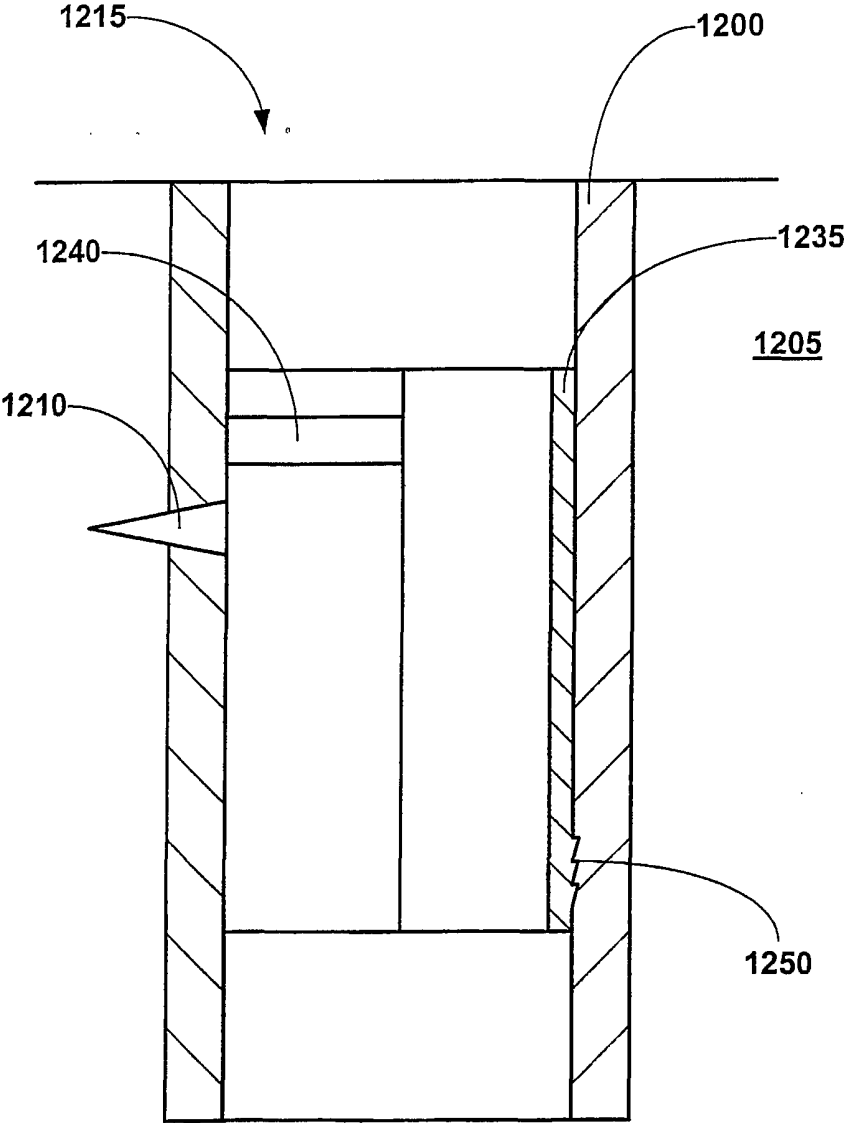

FIGURE 12d

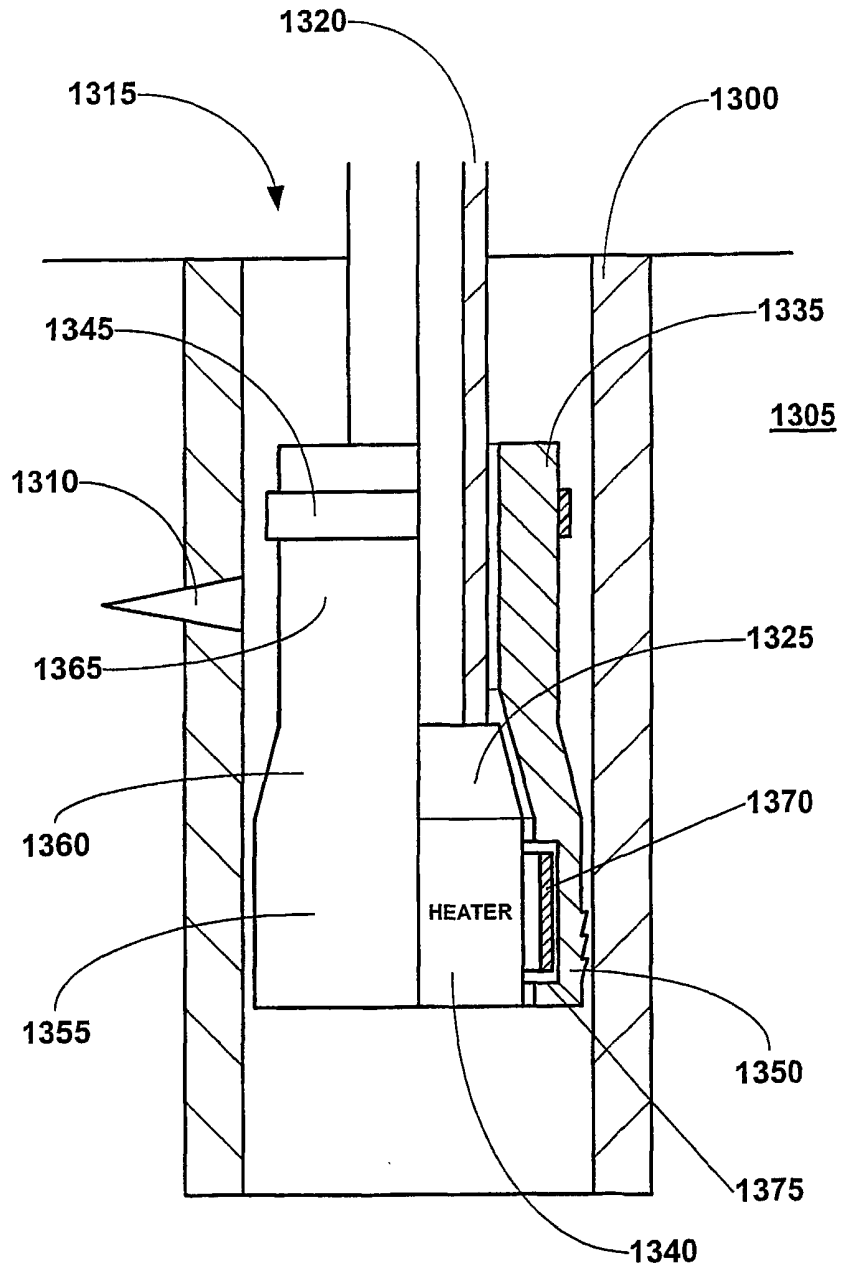

FIGURE 13a

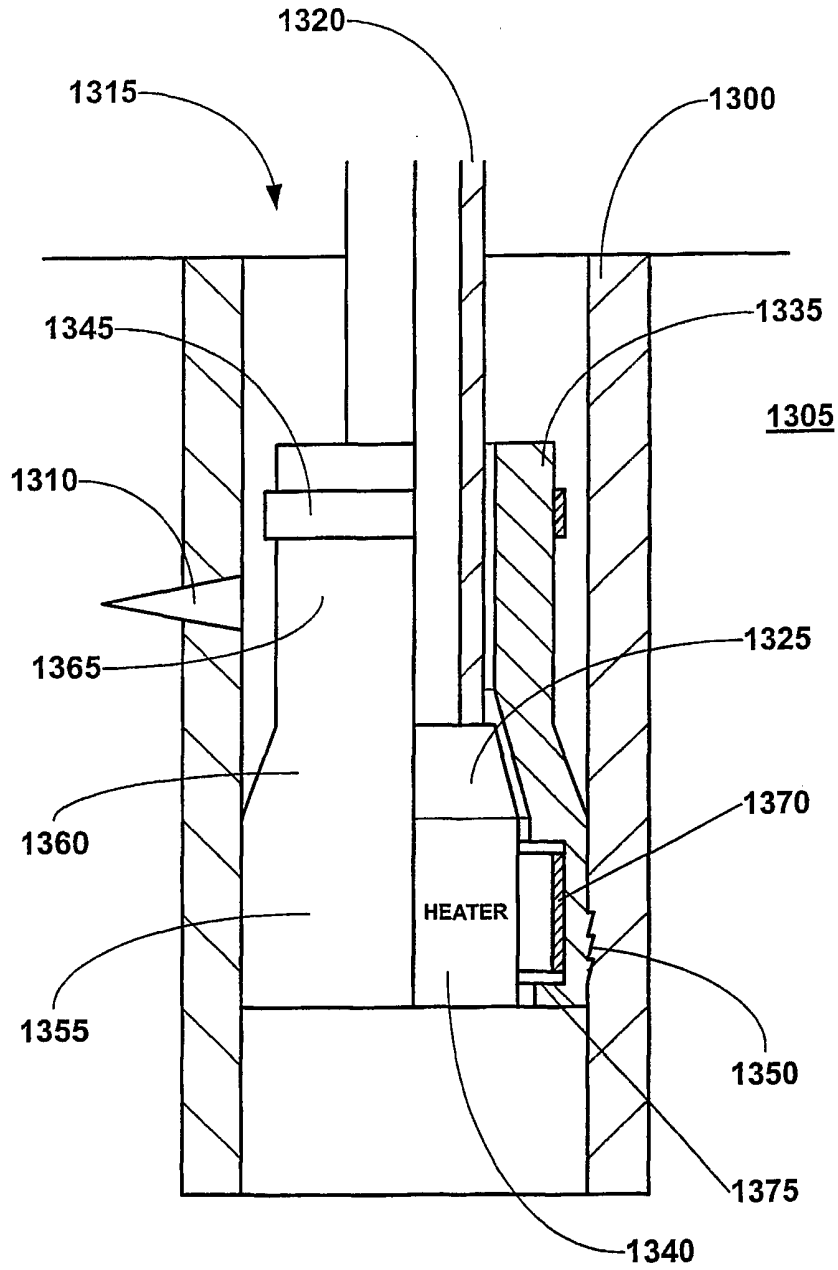

FIGURE 13b

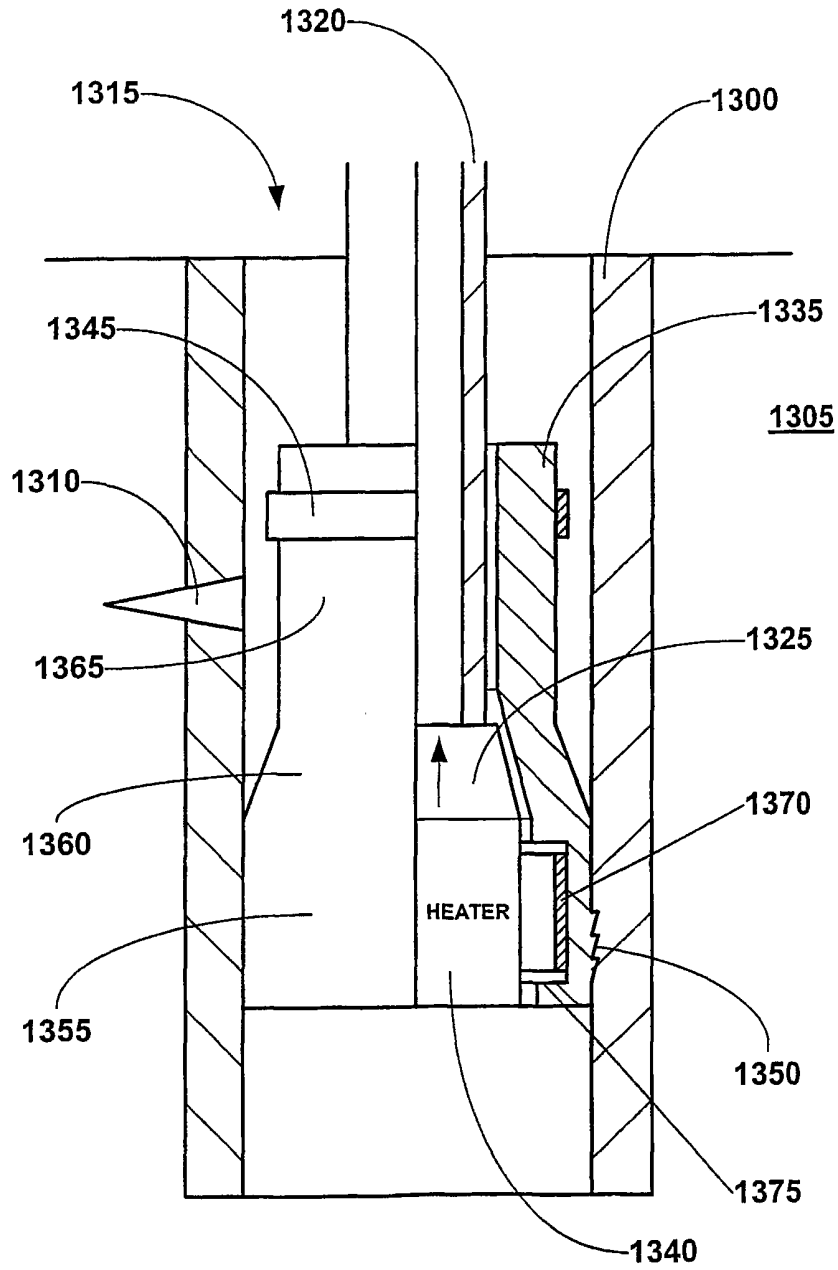

FIGURE 13c



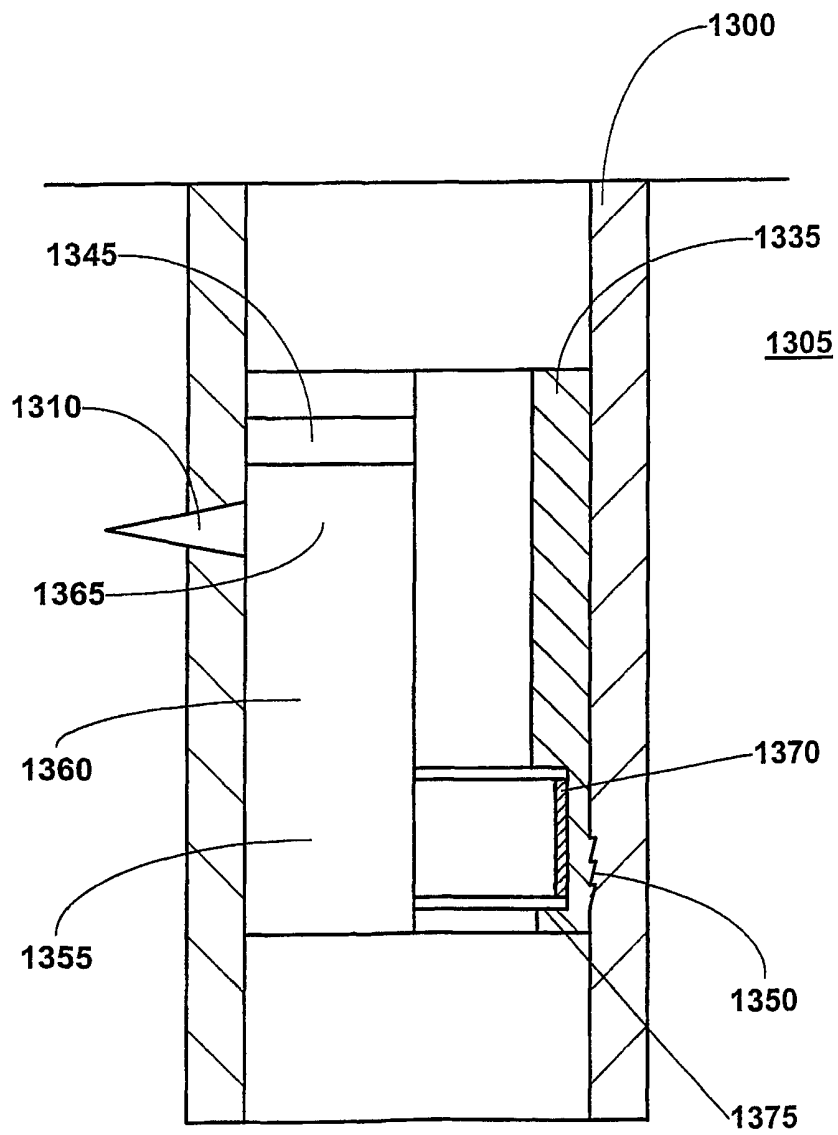

FIGURE 13d

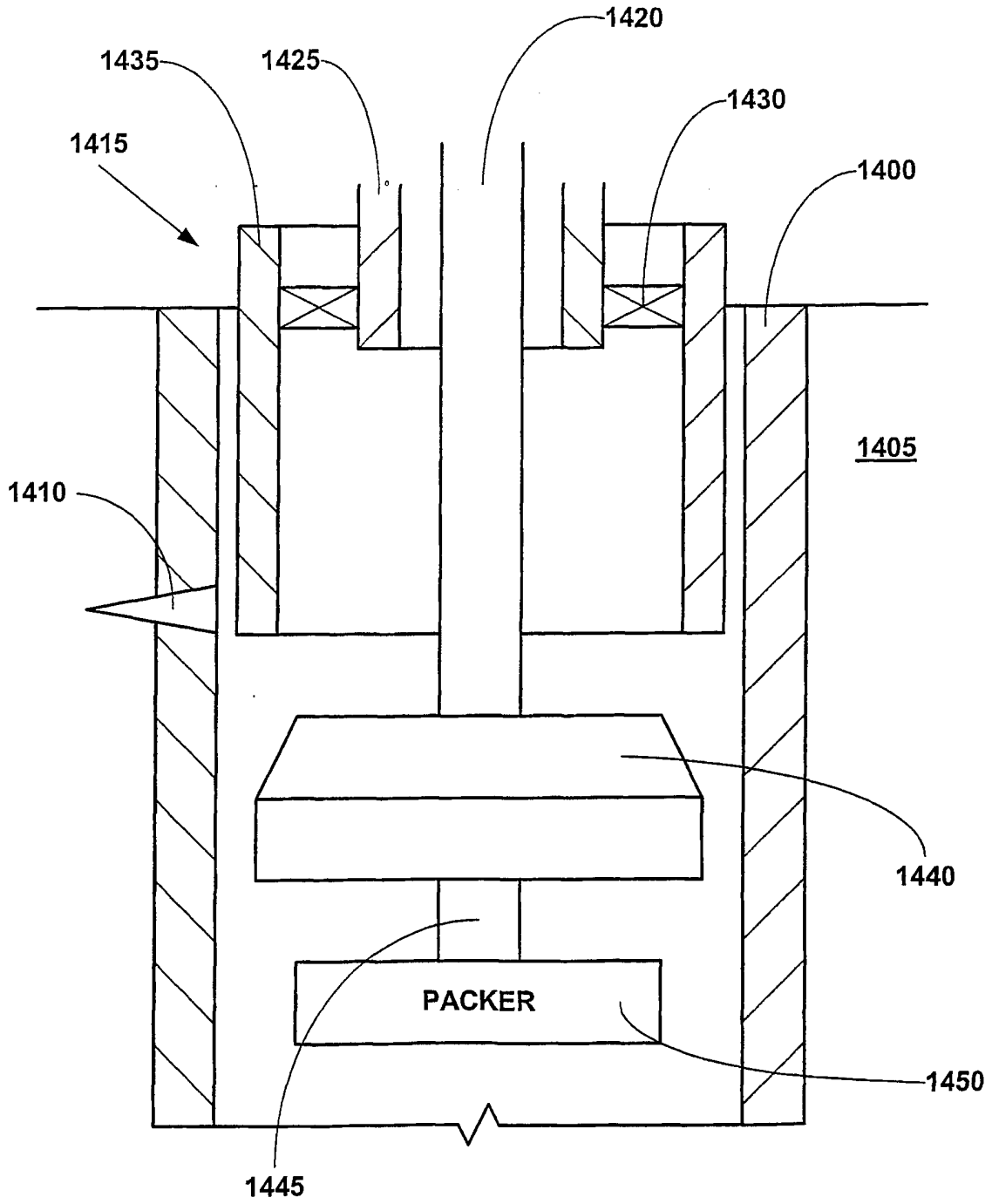

FIGURE 14a

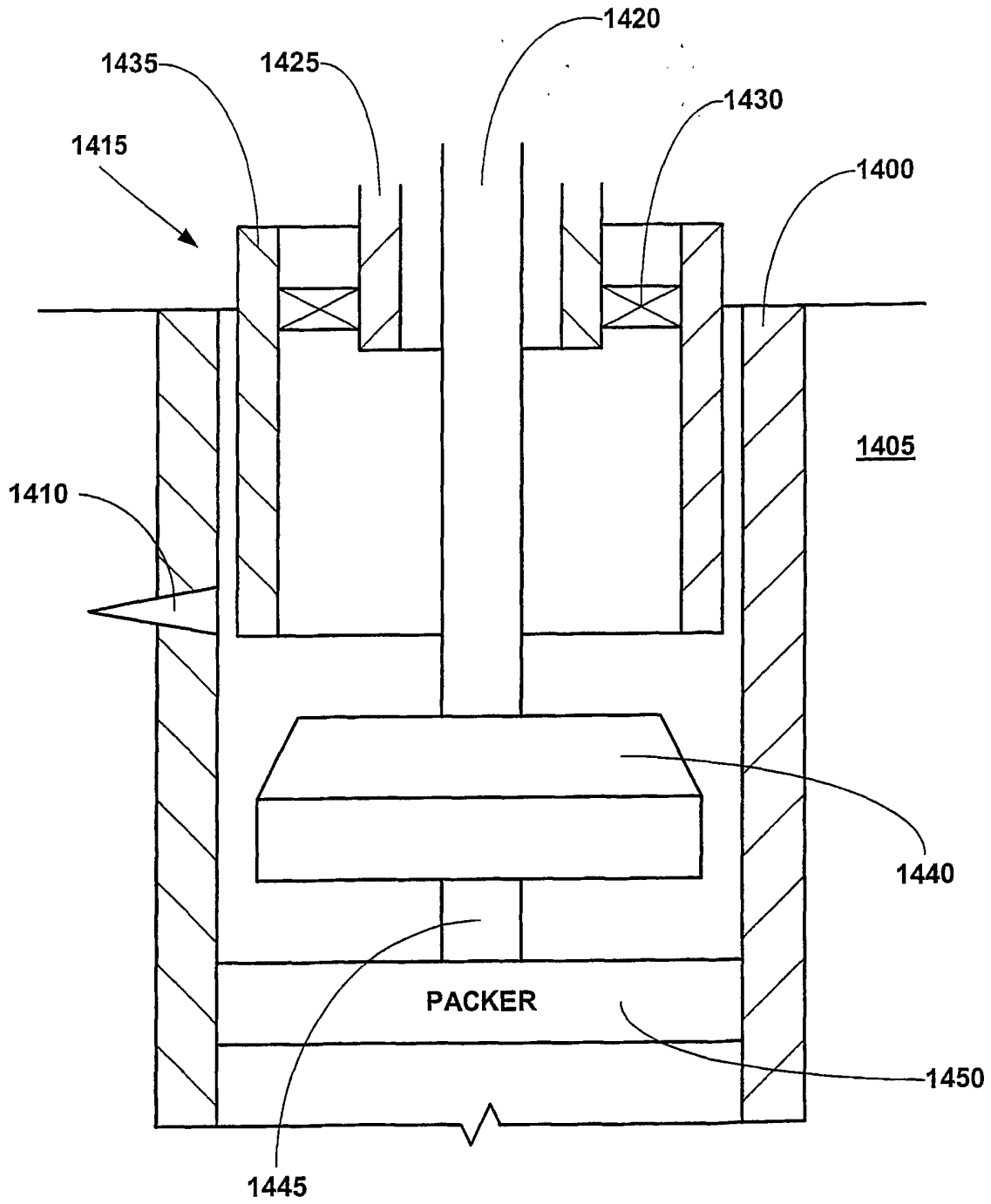

FIGURE 14b

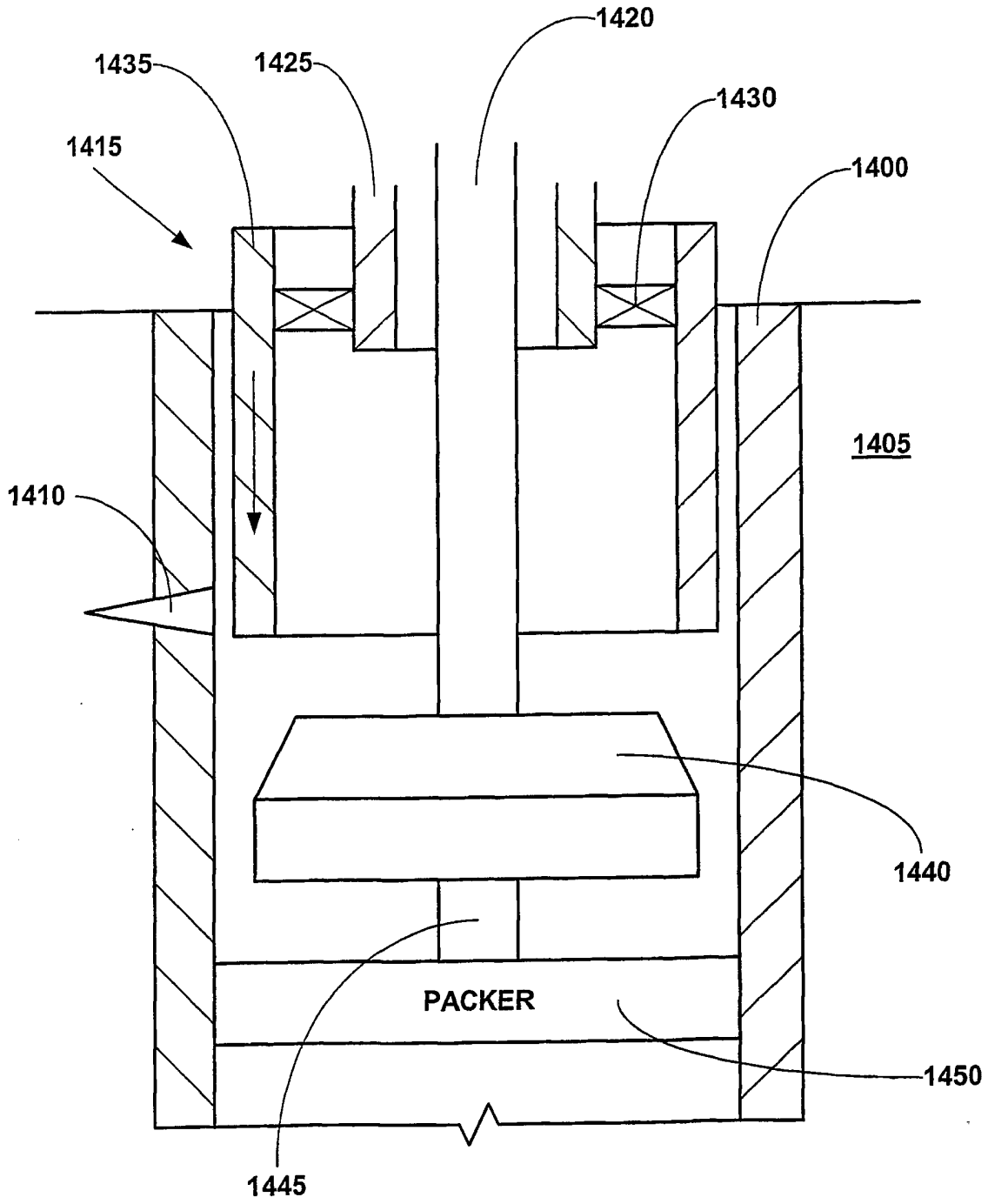

FIGURE 14c

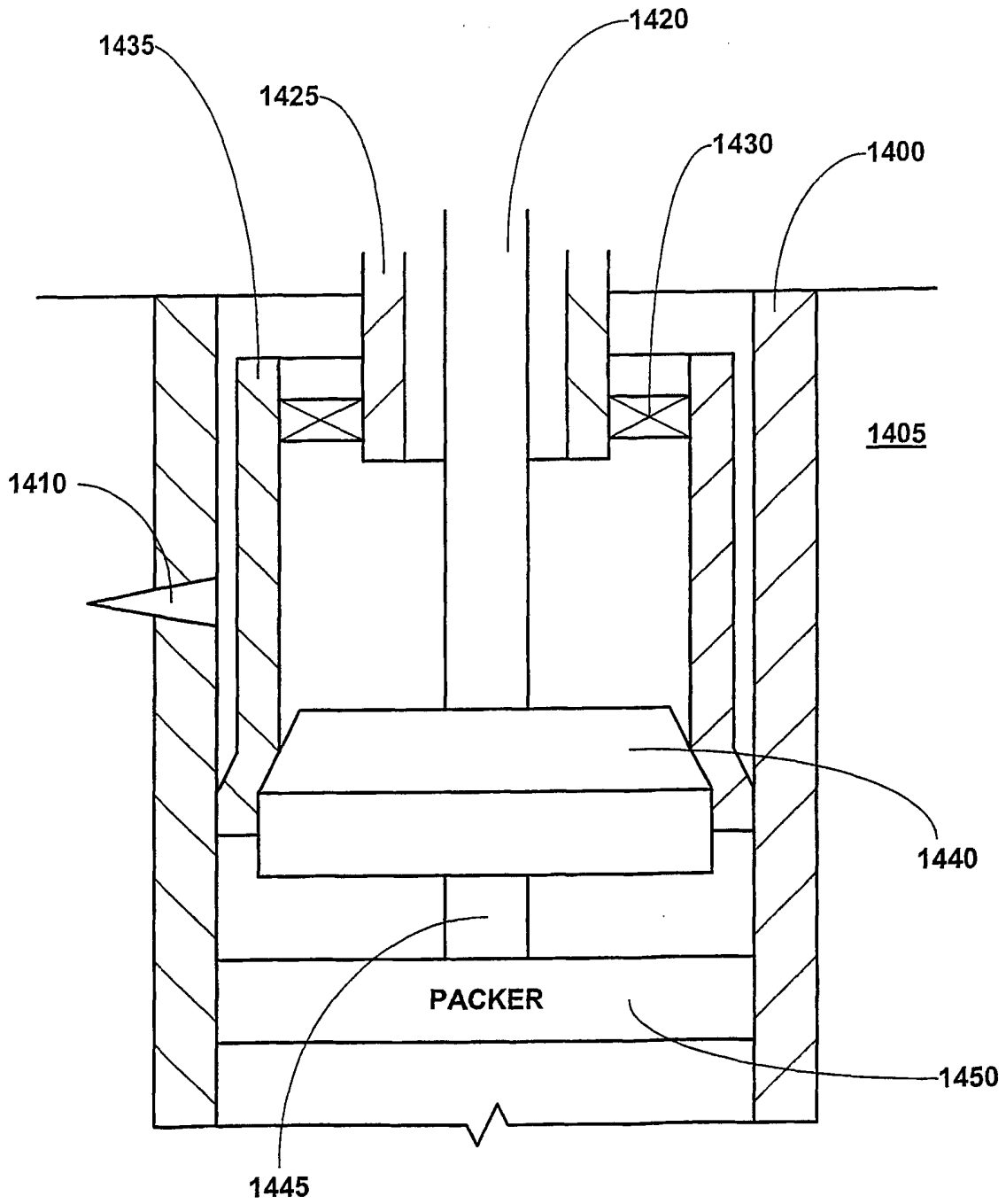

FIGURE 14d

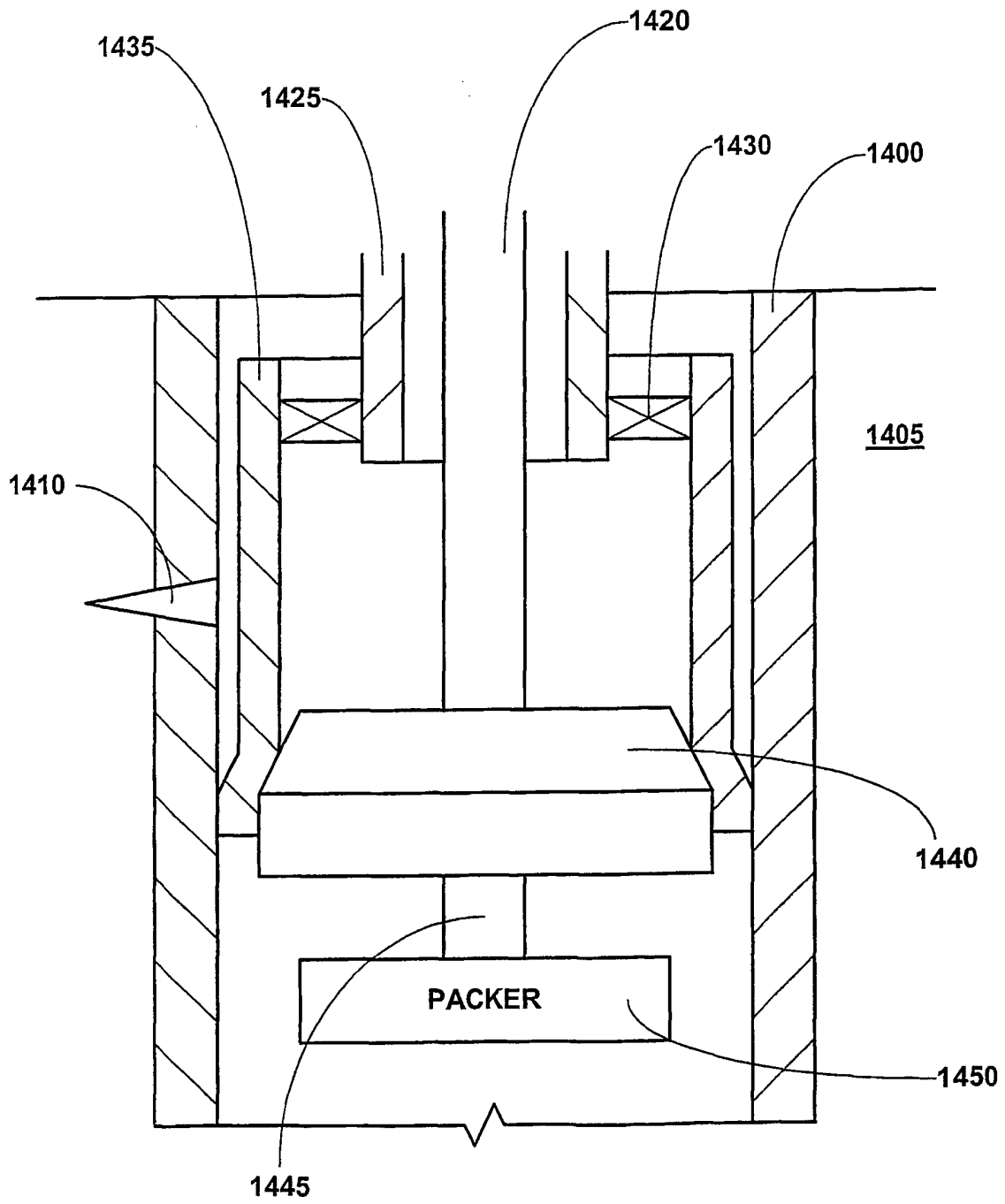

FIGURE 14e

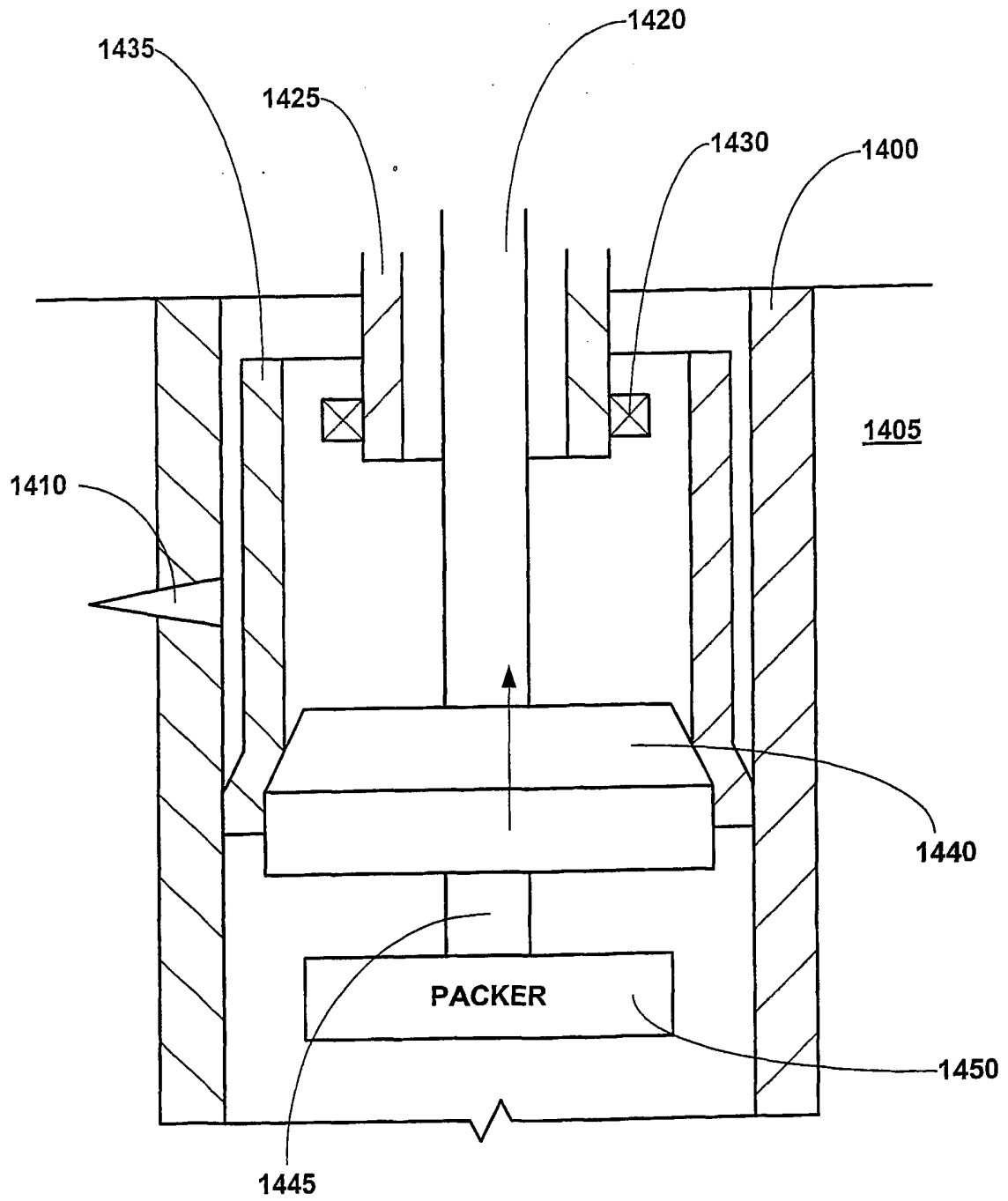

FIGURE 14f

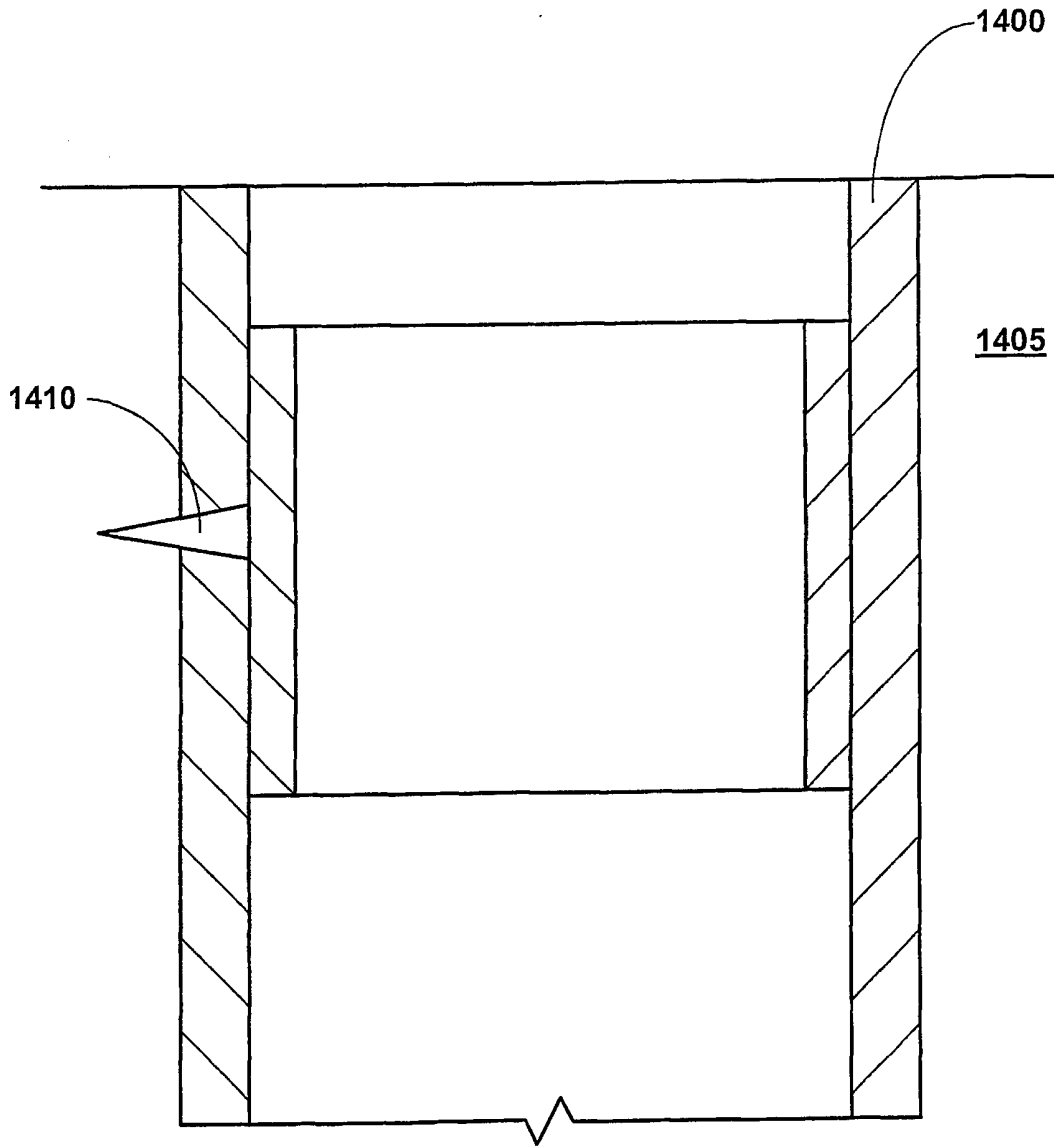
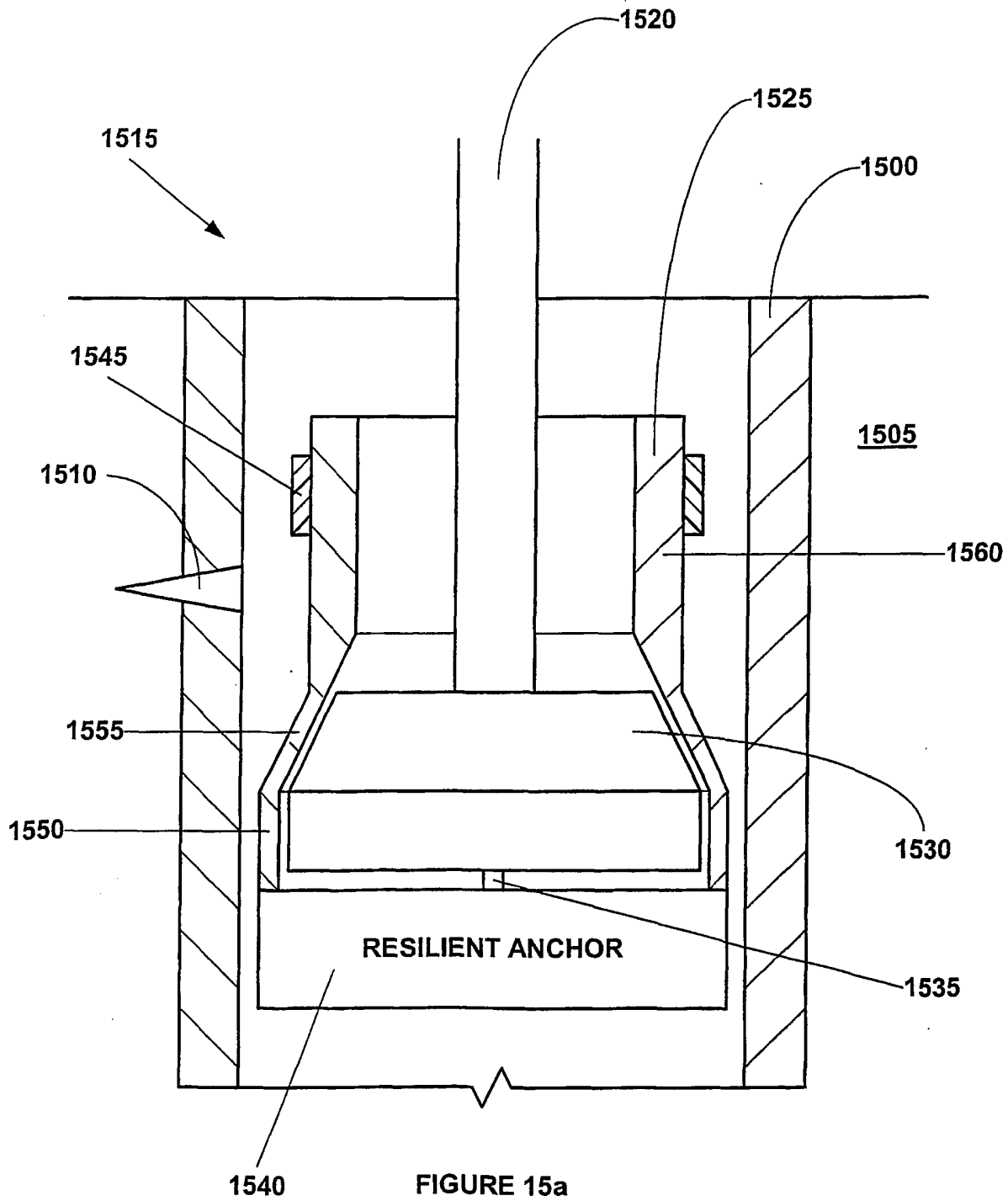

FIGURE 14g





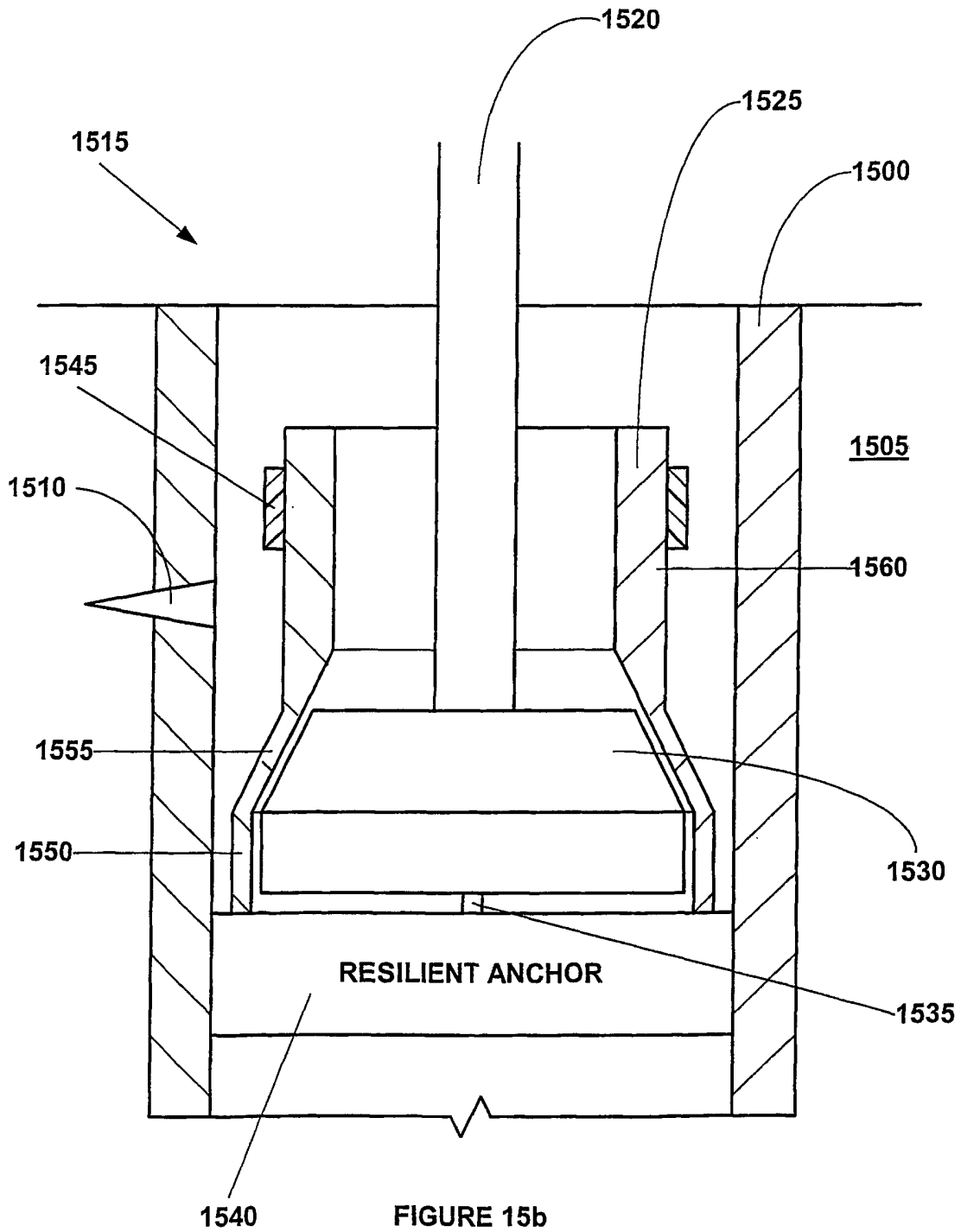

FIGURE 15b

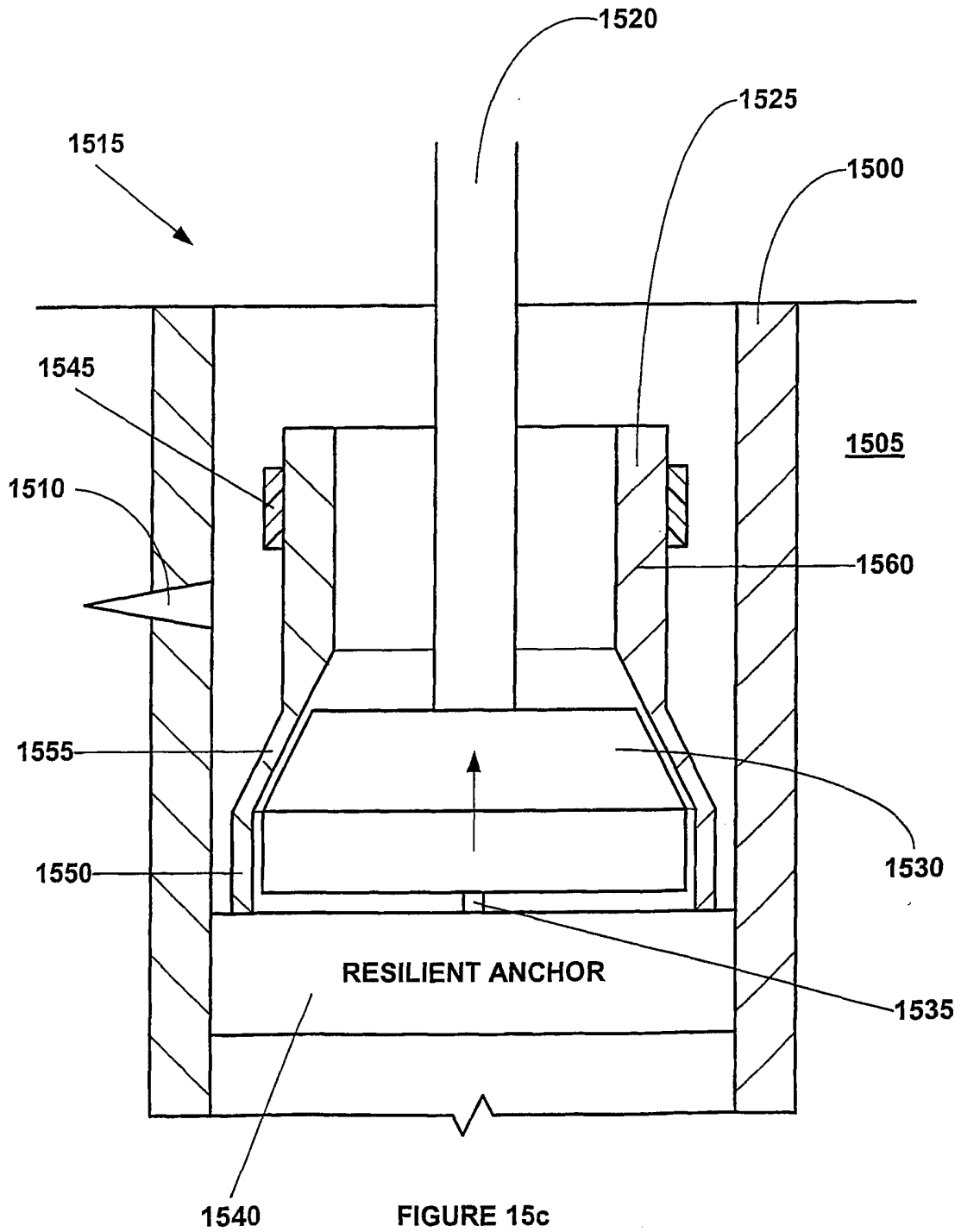
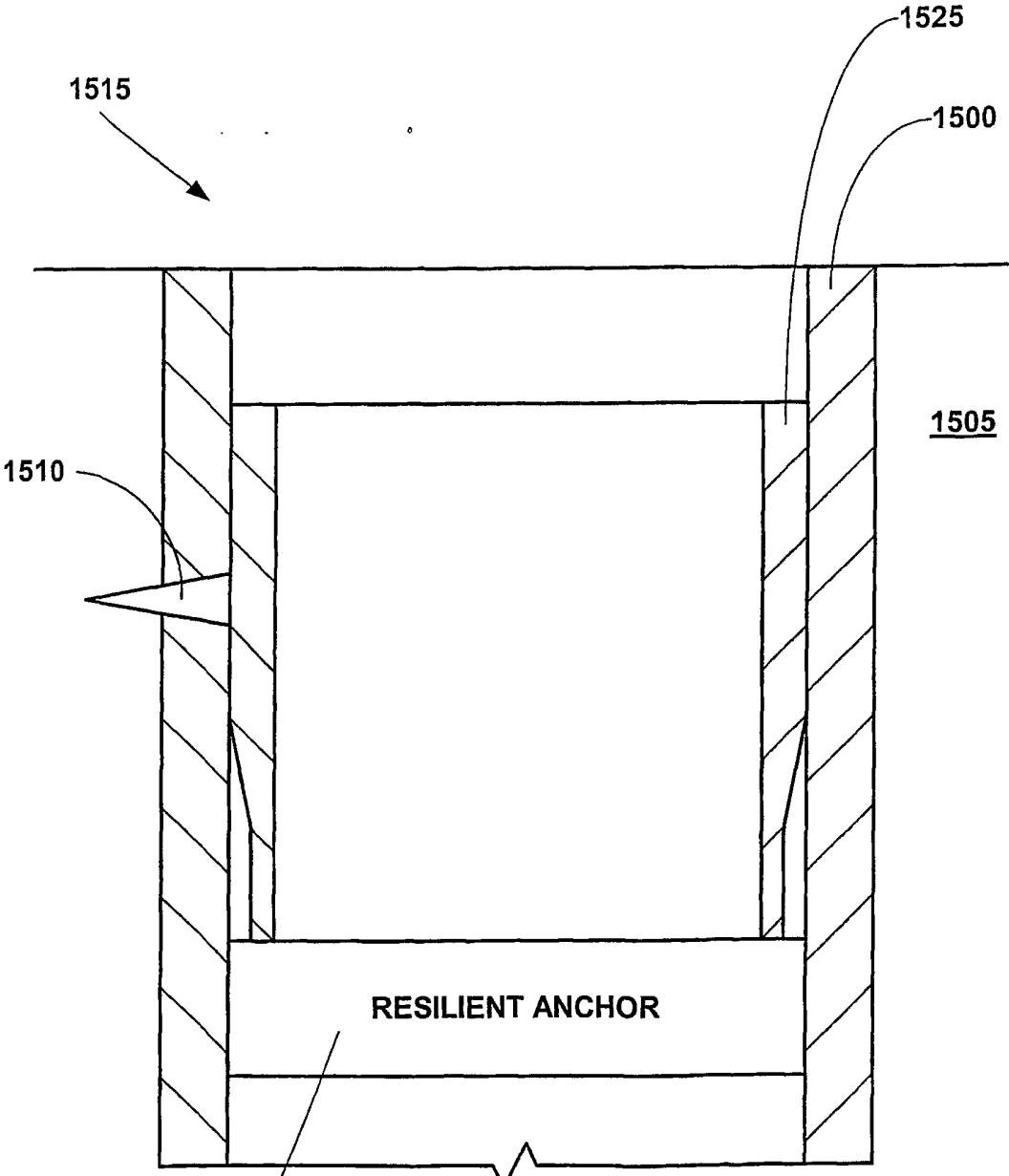

FIGURE 15c



1540

FIGURE 15d

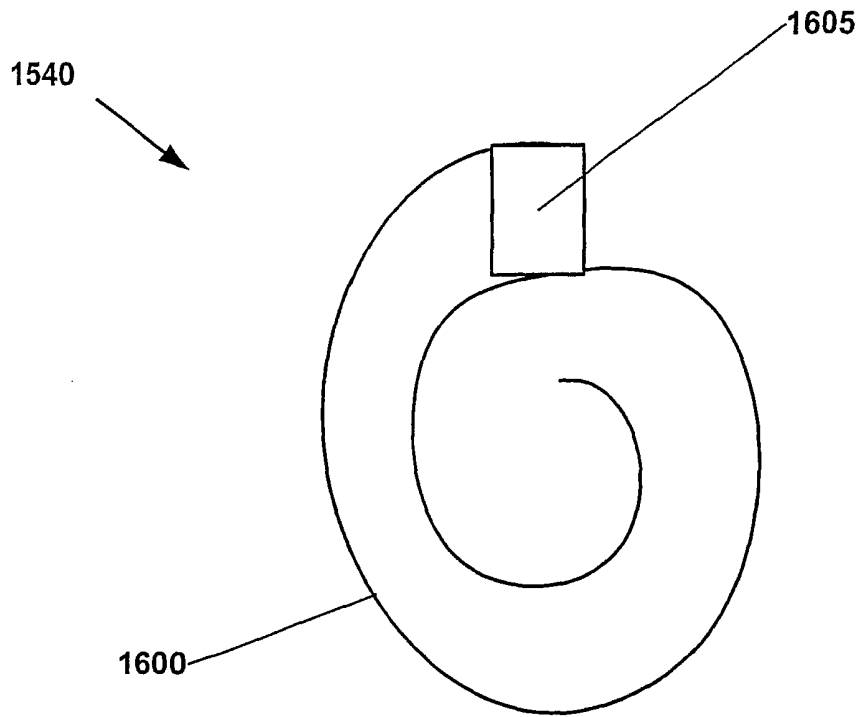

FIGURE 16a

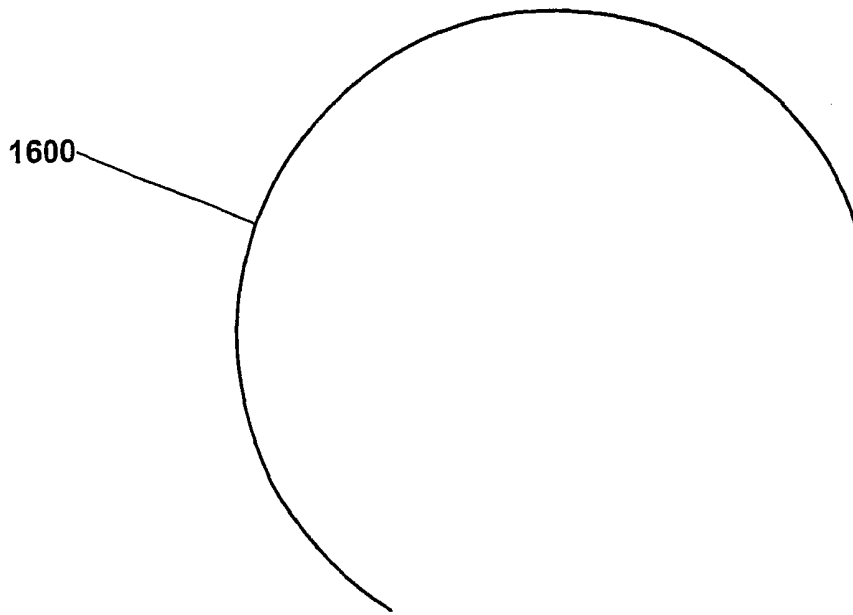

FIGURE 16b

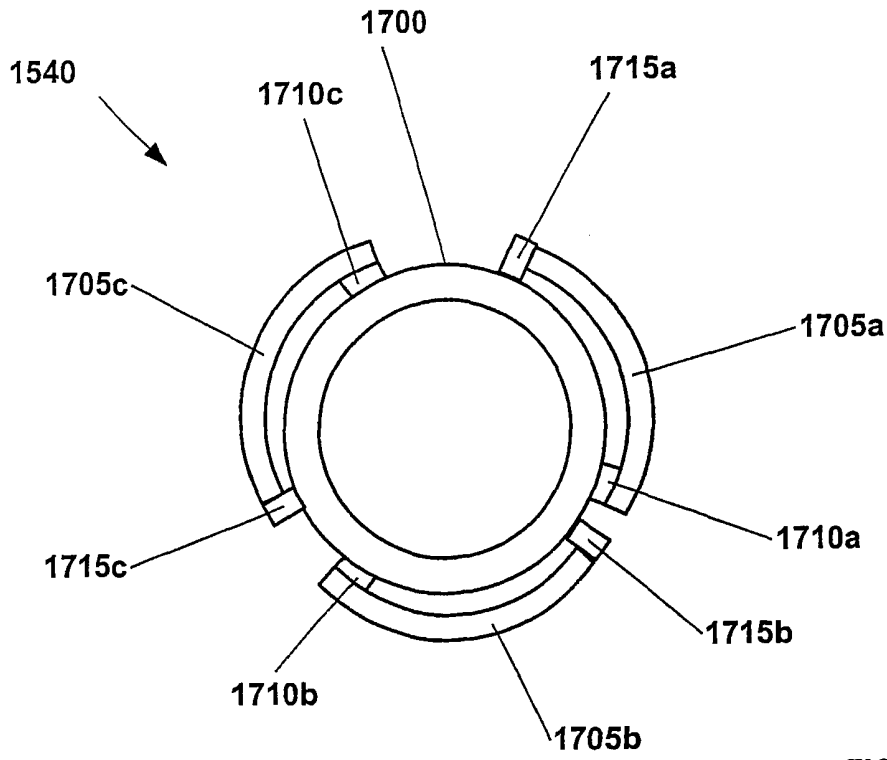

FIGURE 17a

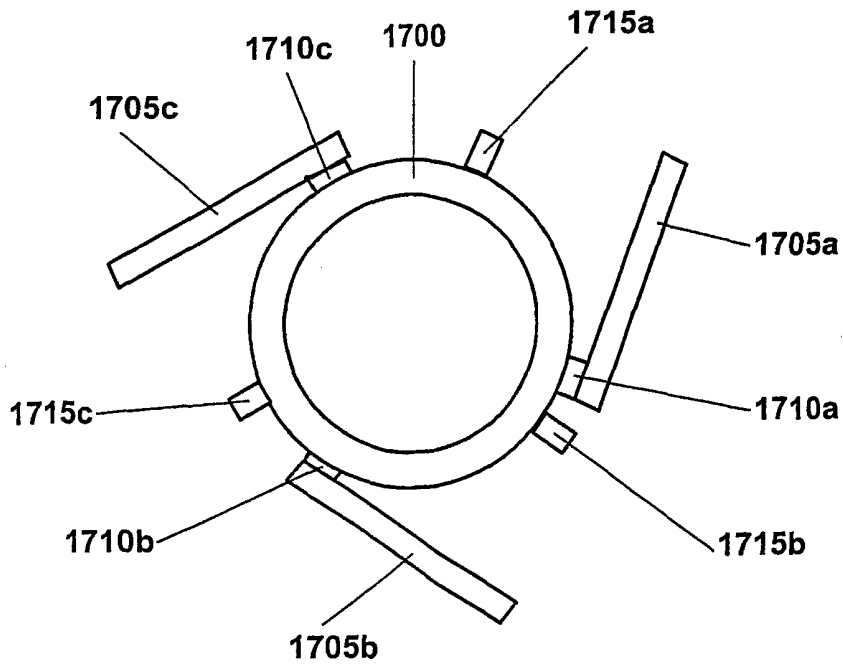

FIGURE 17b

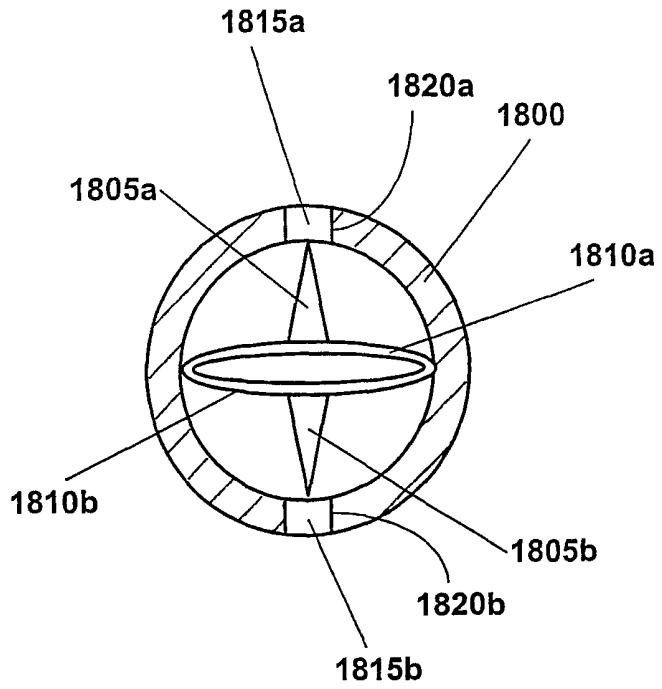

FIGURE 18a

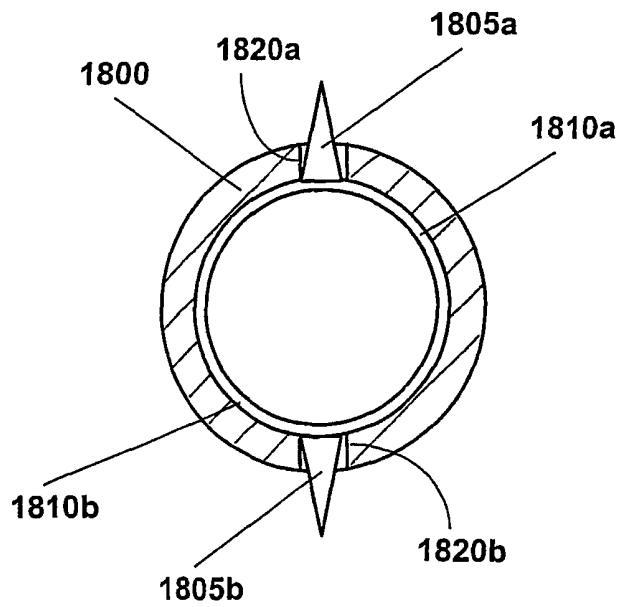

FIGURE 18b

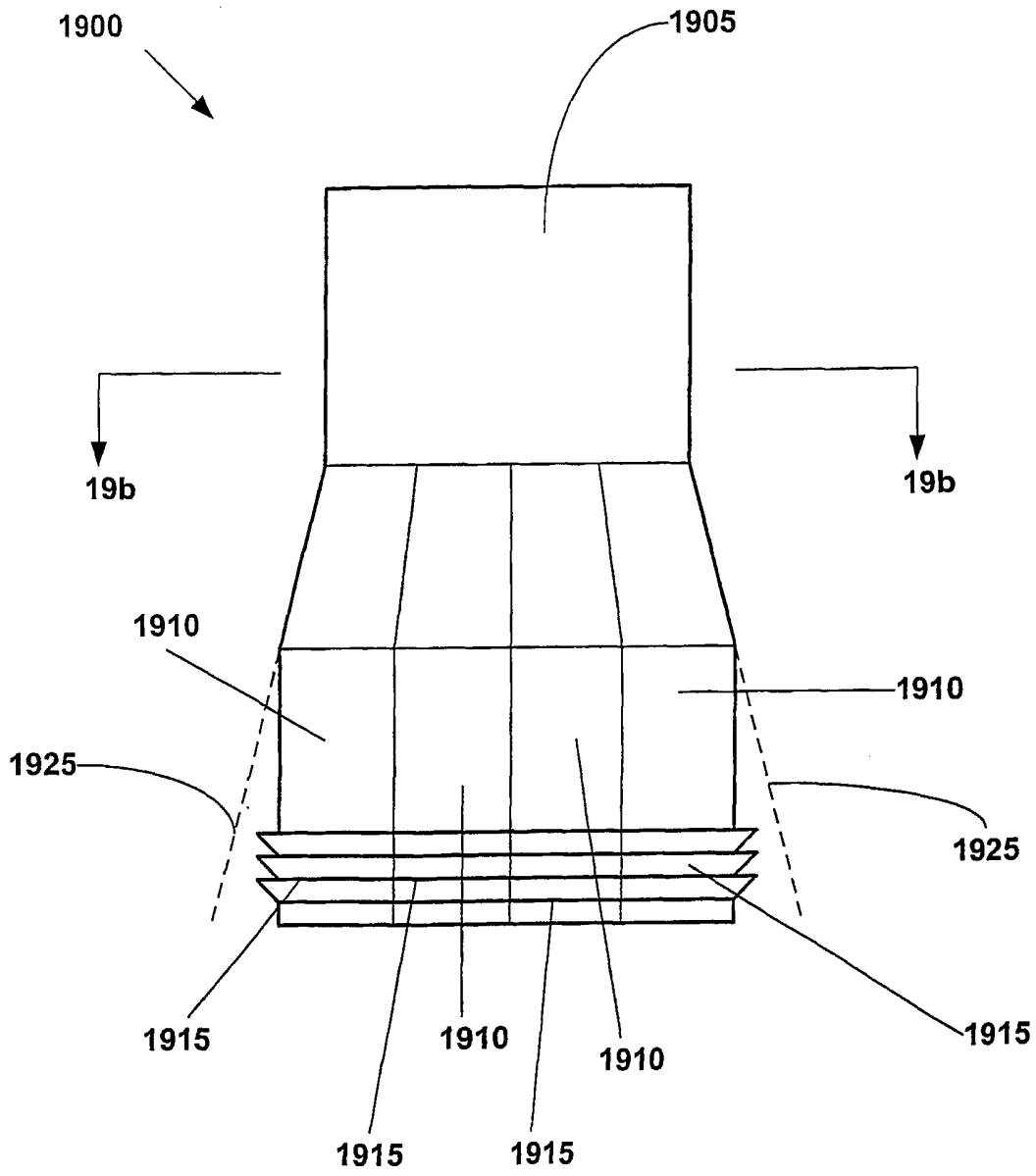

FIGURE 19a



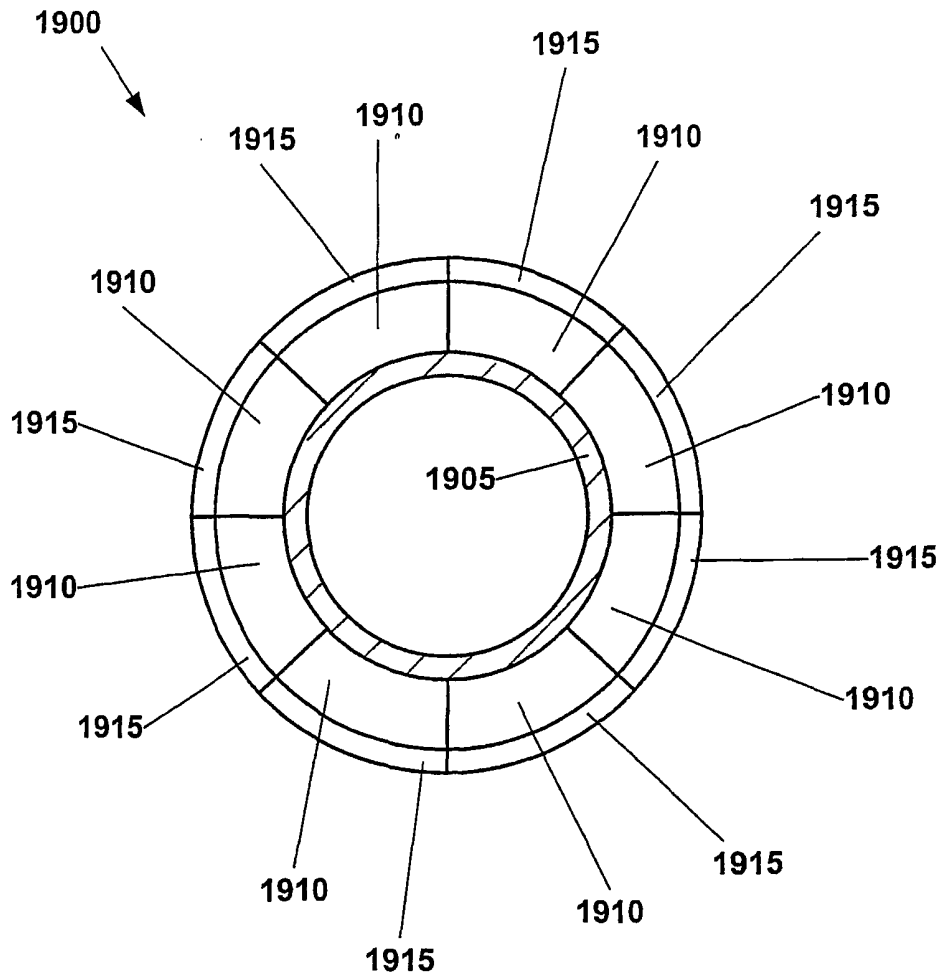

FIGURE 19b

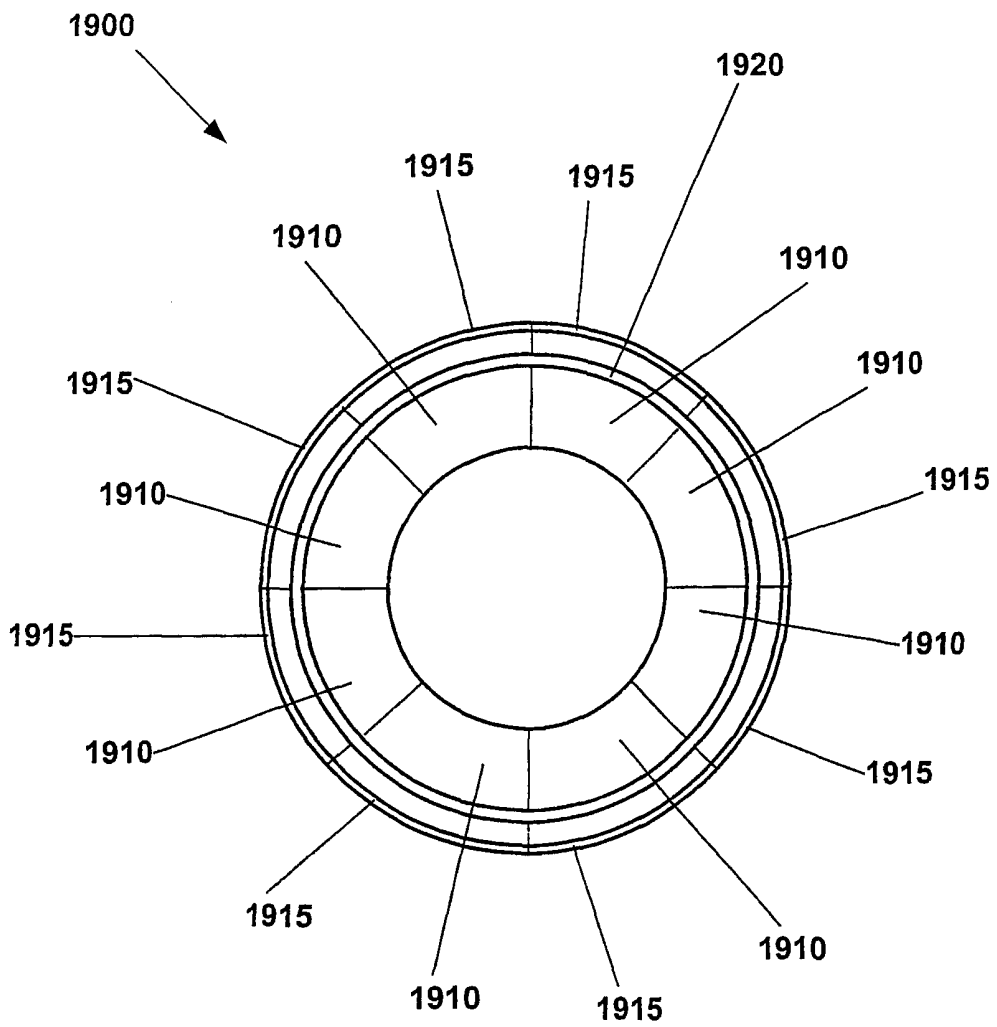

FIGURE 19c

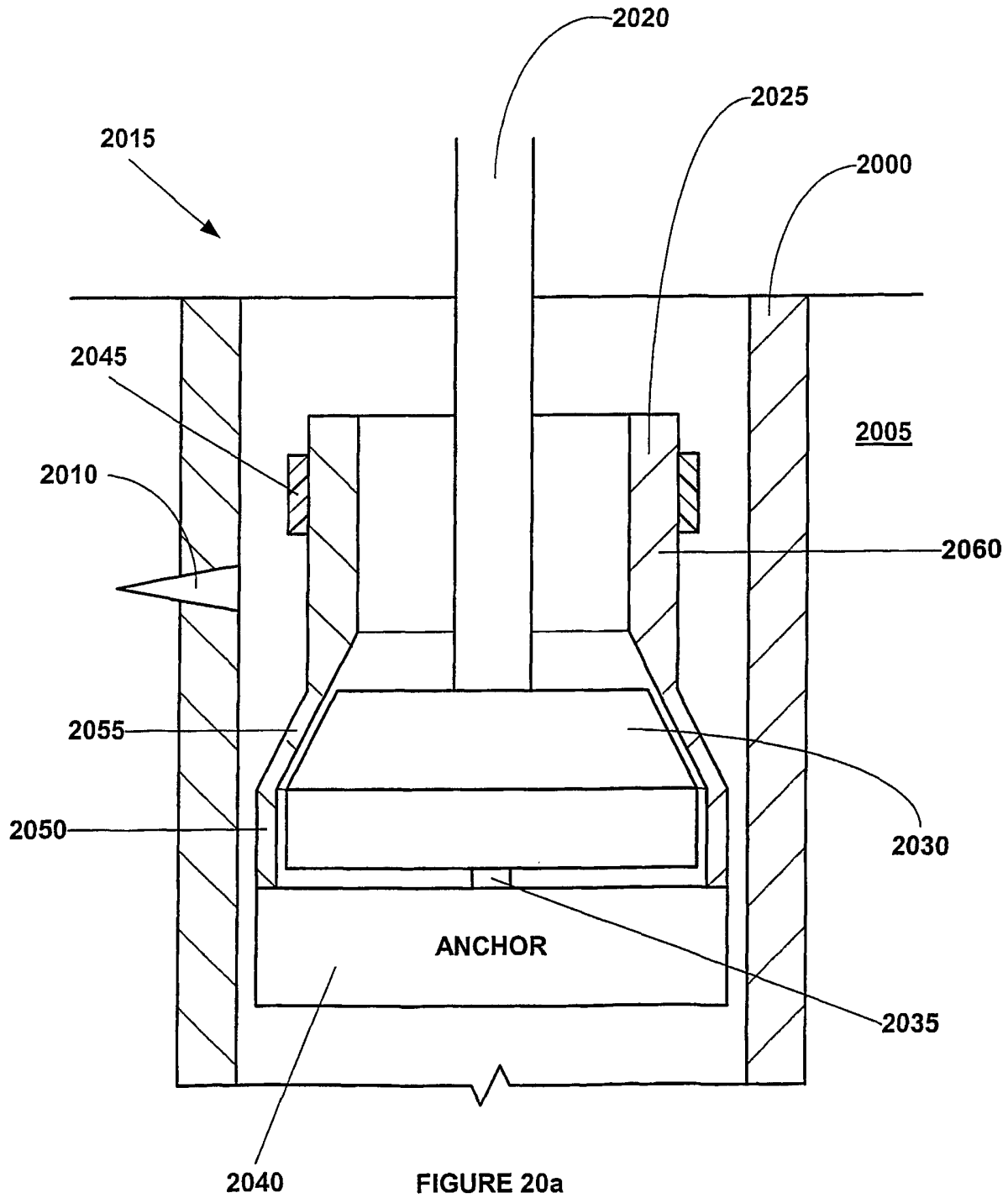

FIGURE 20a

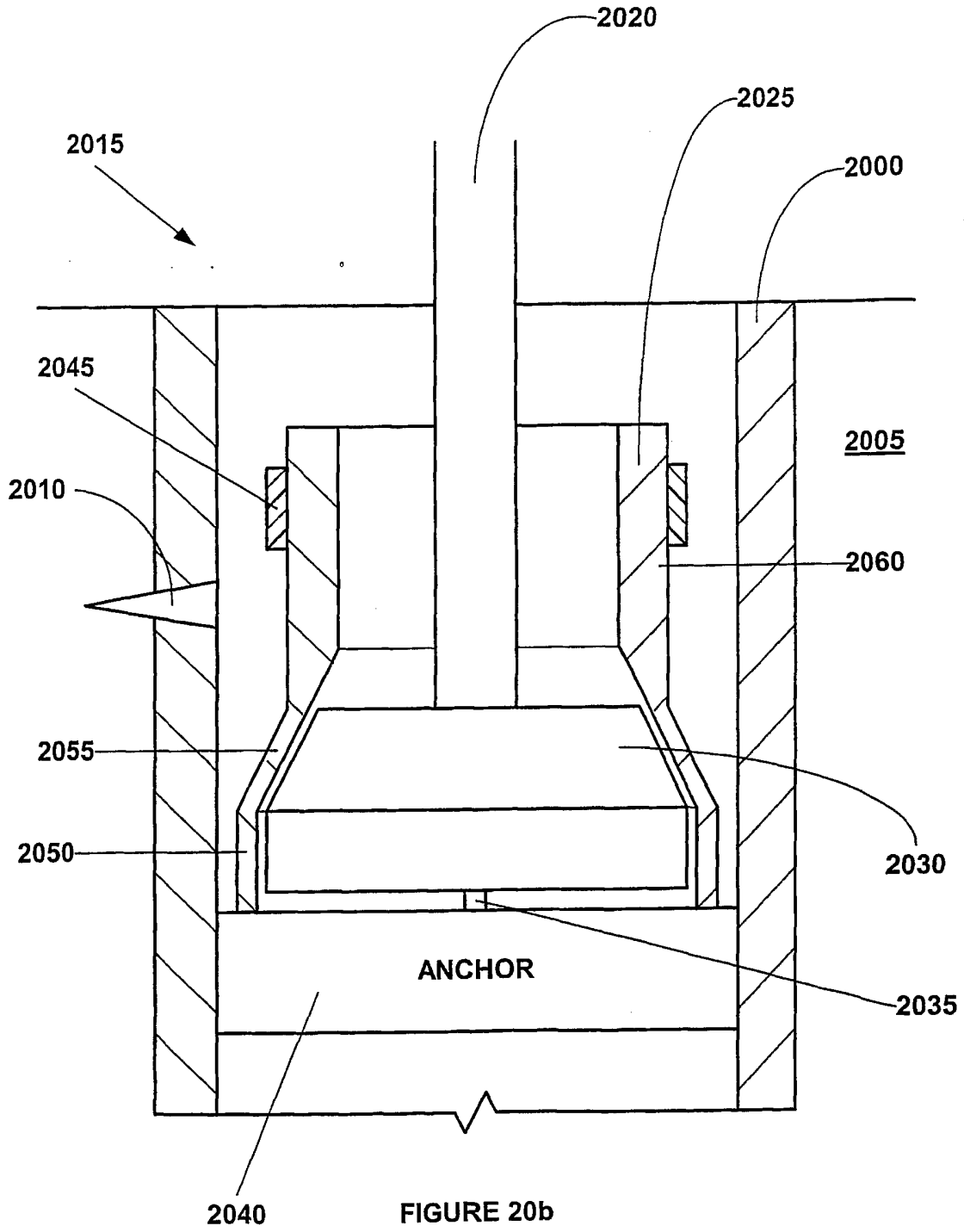

FIGURE 20b

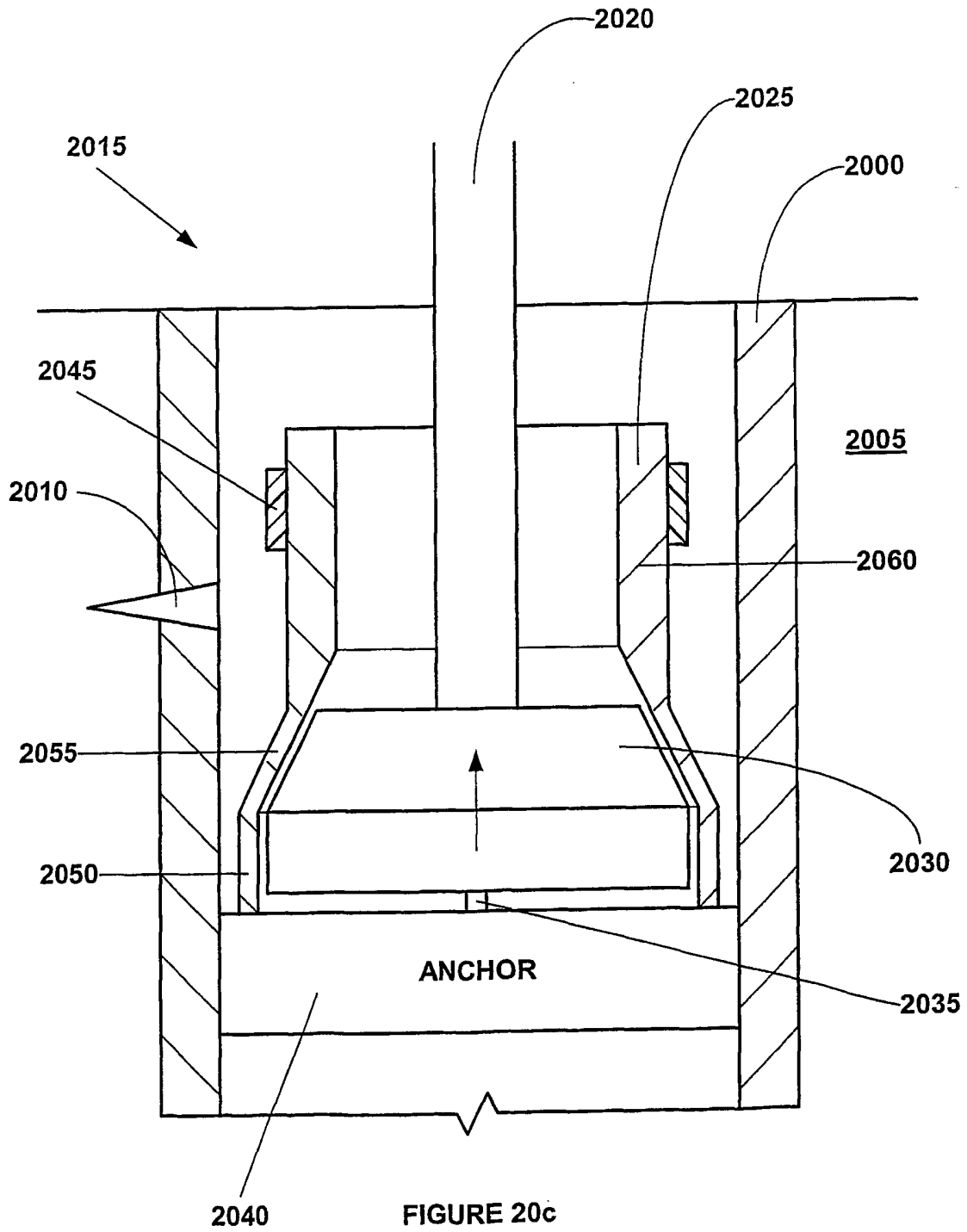

FIGURE 20c

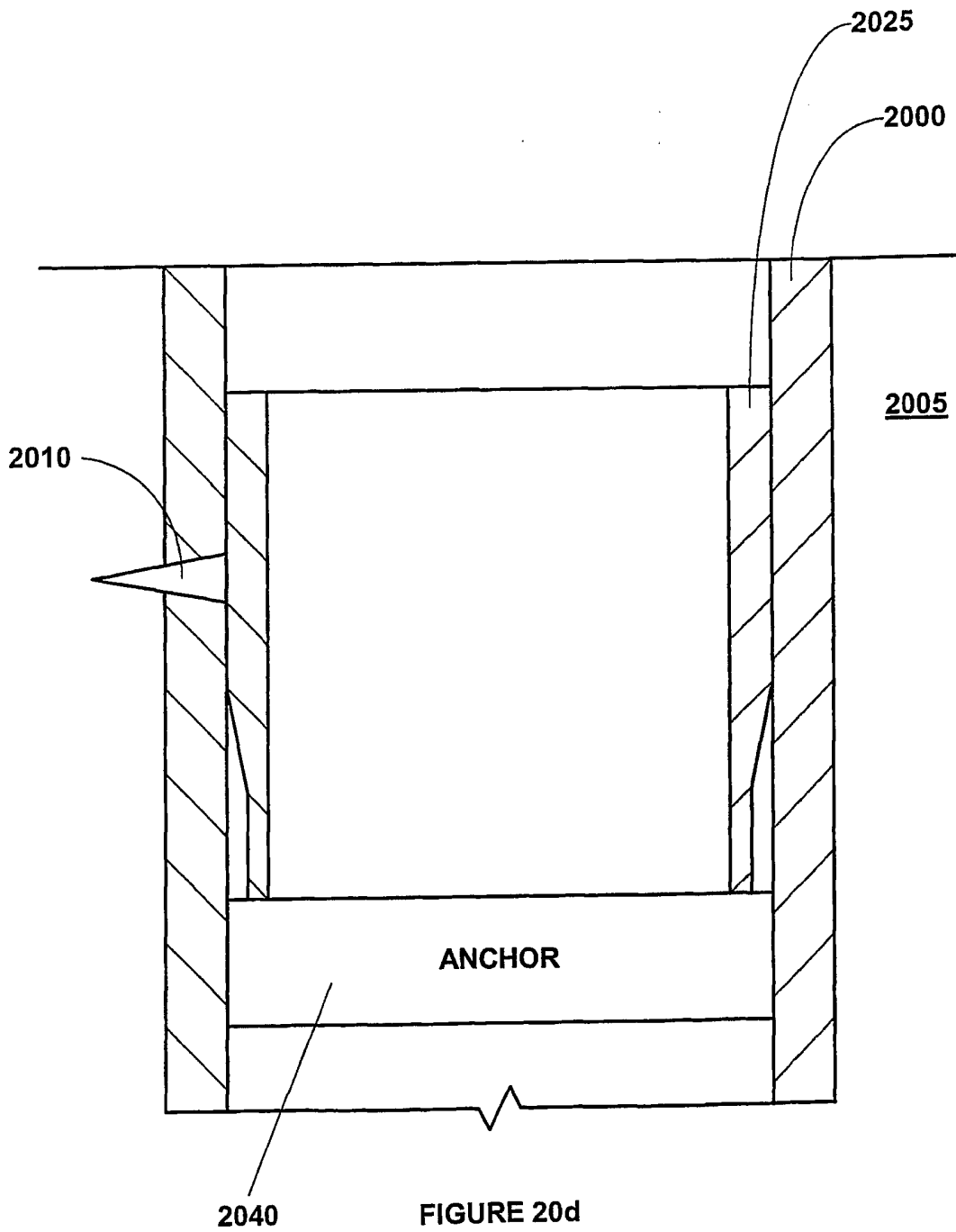

FIGURE 20d

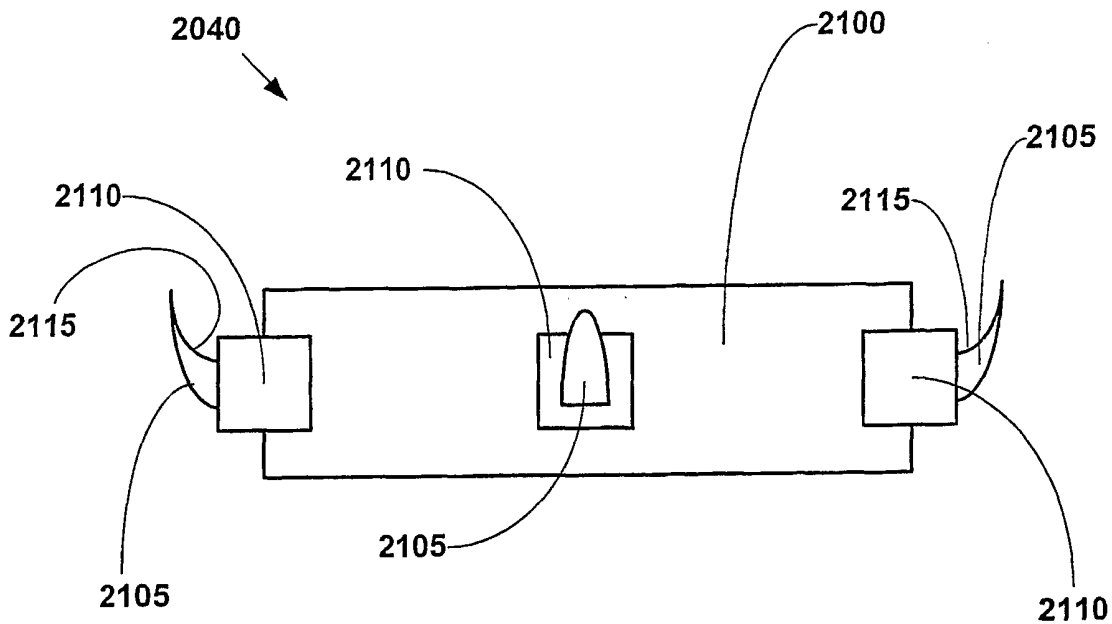

FIGURE 21a

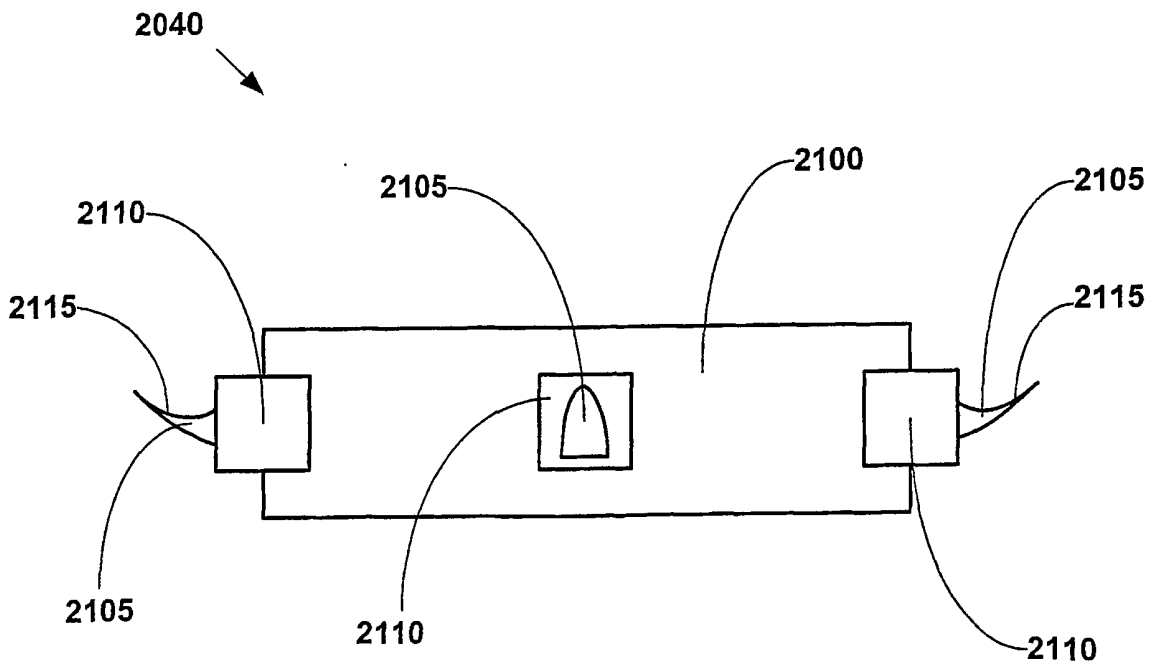

FIGURE 21b

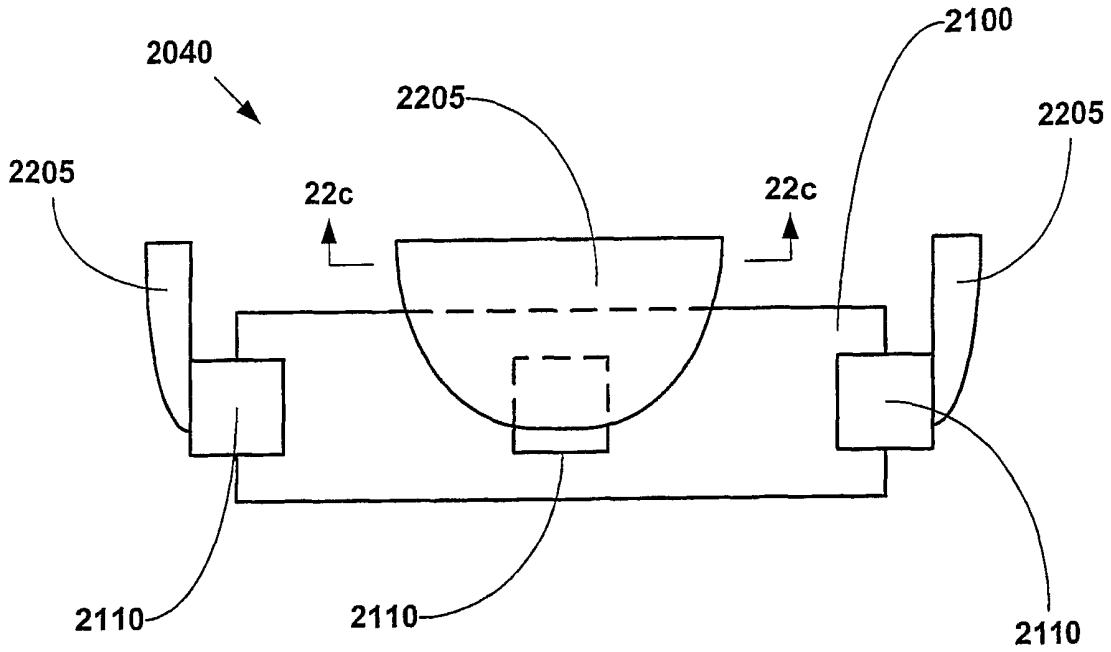

FIGURE 22a

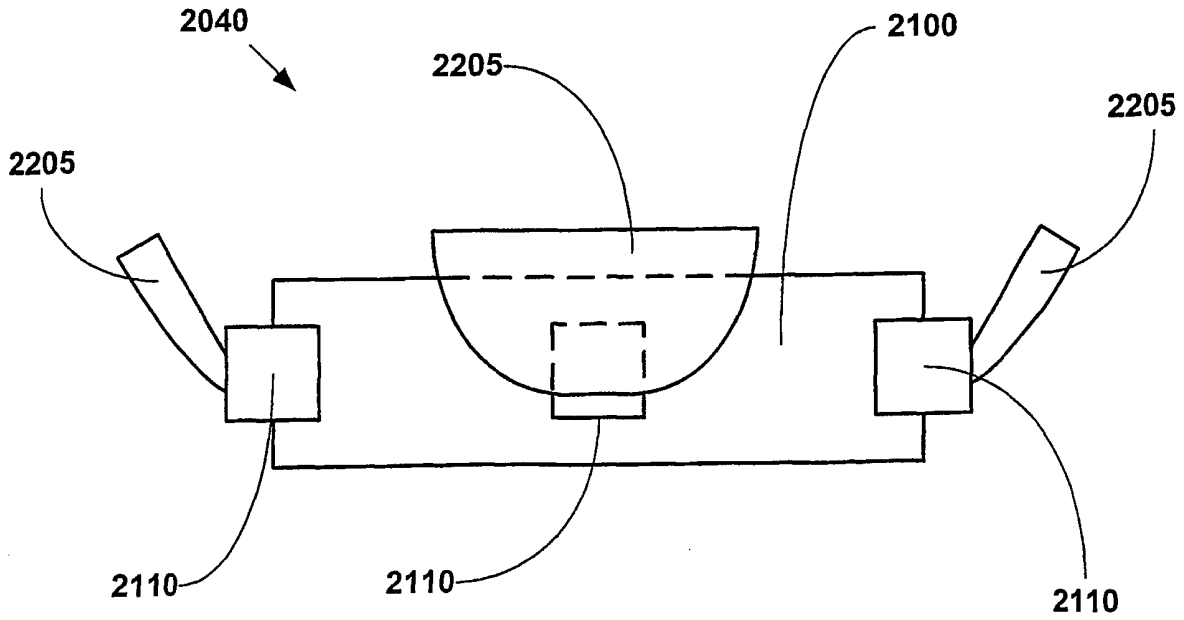
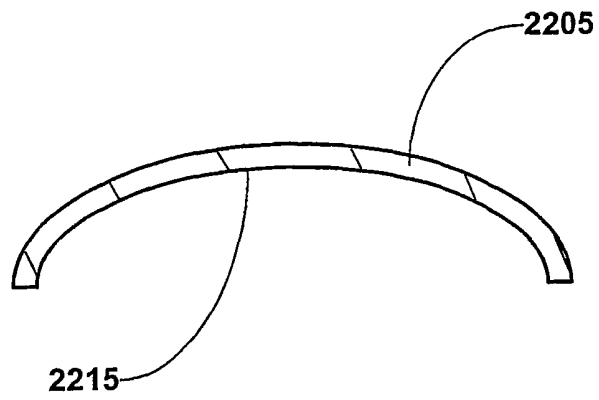

FIGURE 22b





**FIGURE 22c**

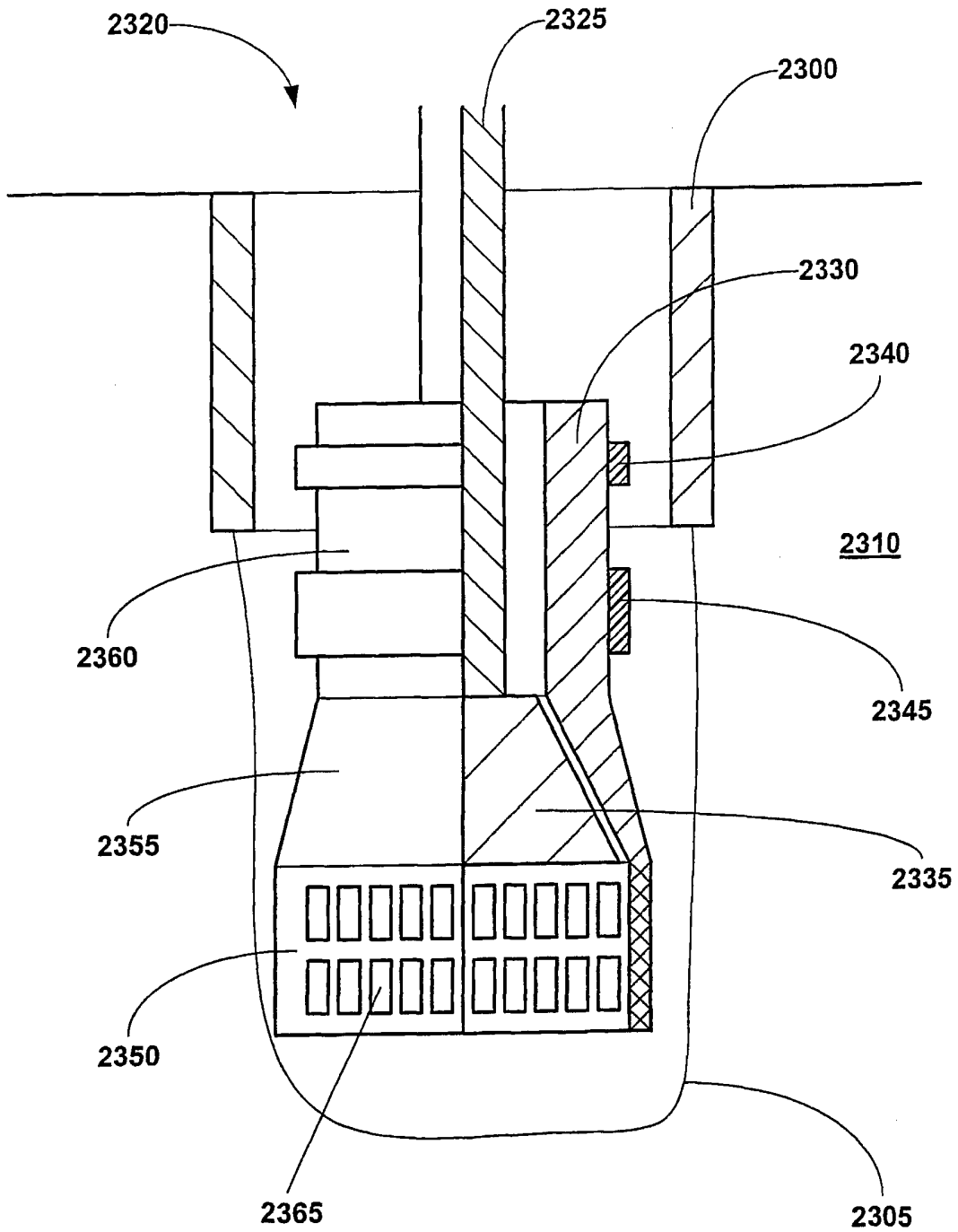

FIGURE 23a

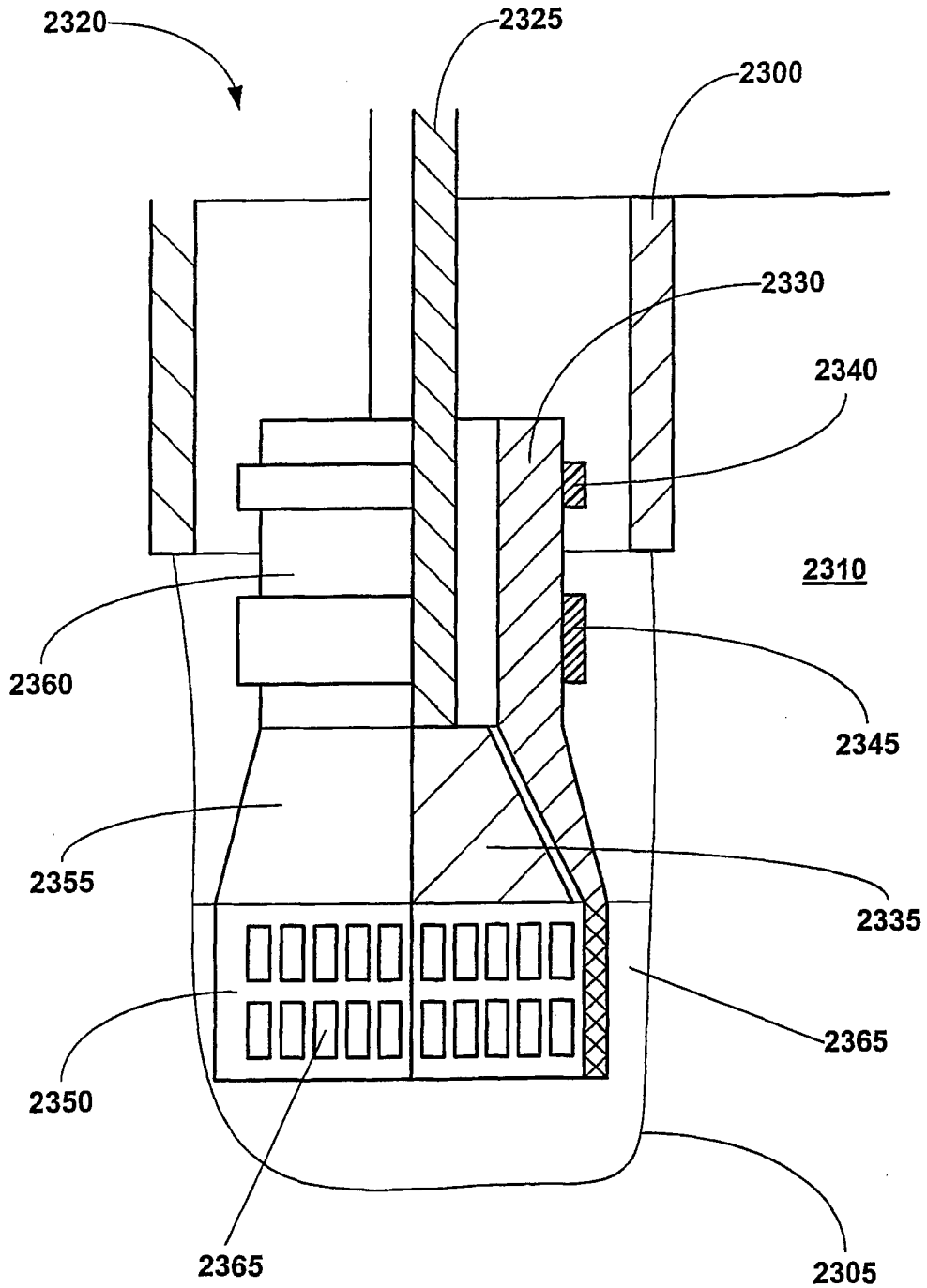

FIGURE 23b

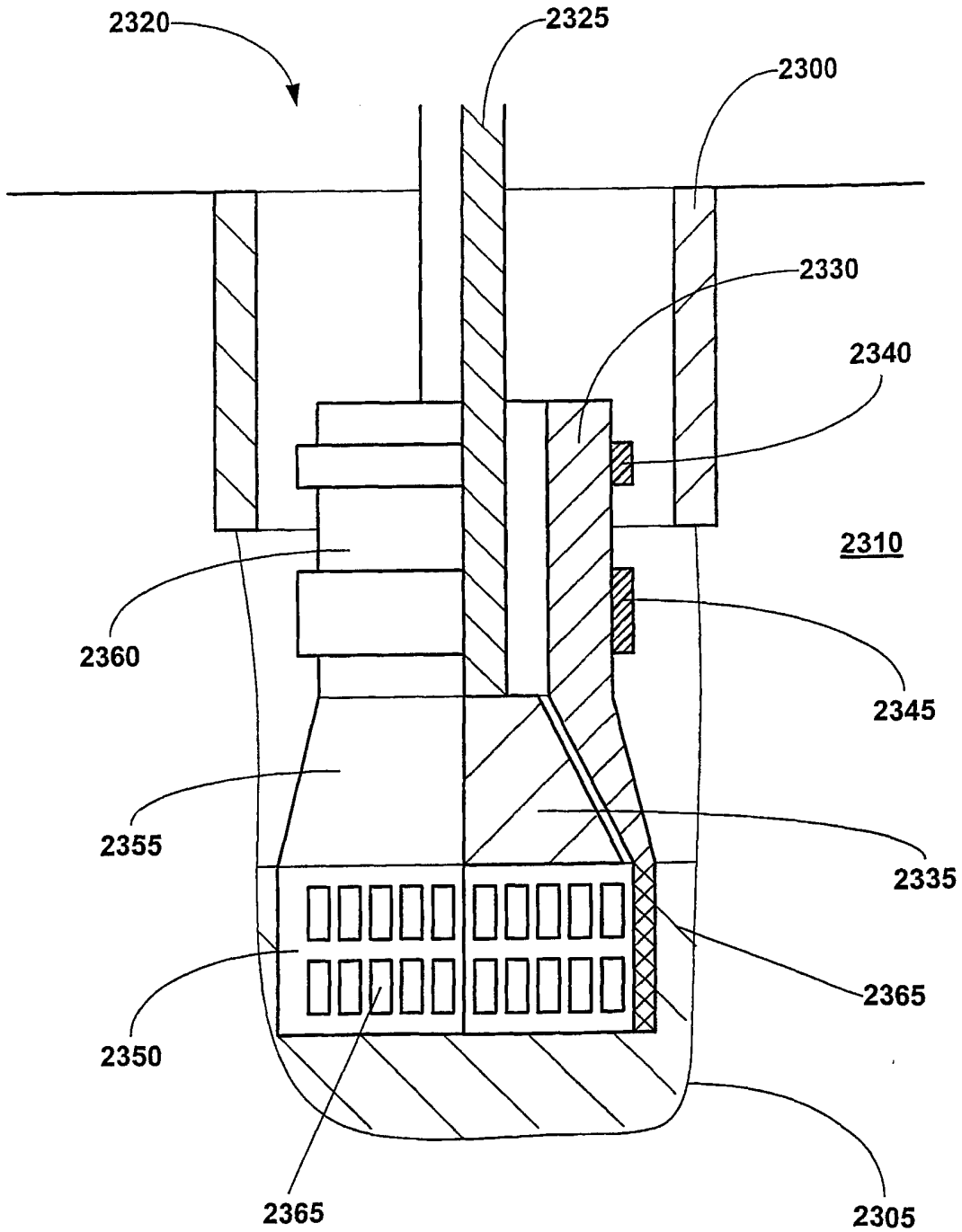

FIGURE 23c

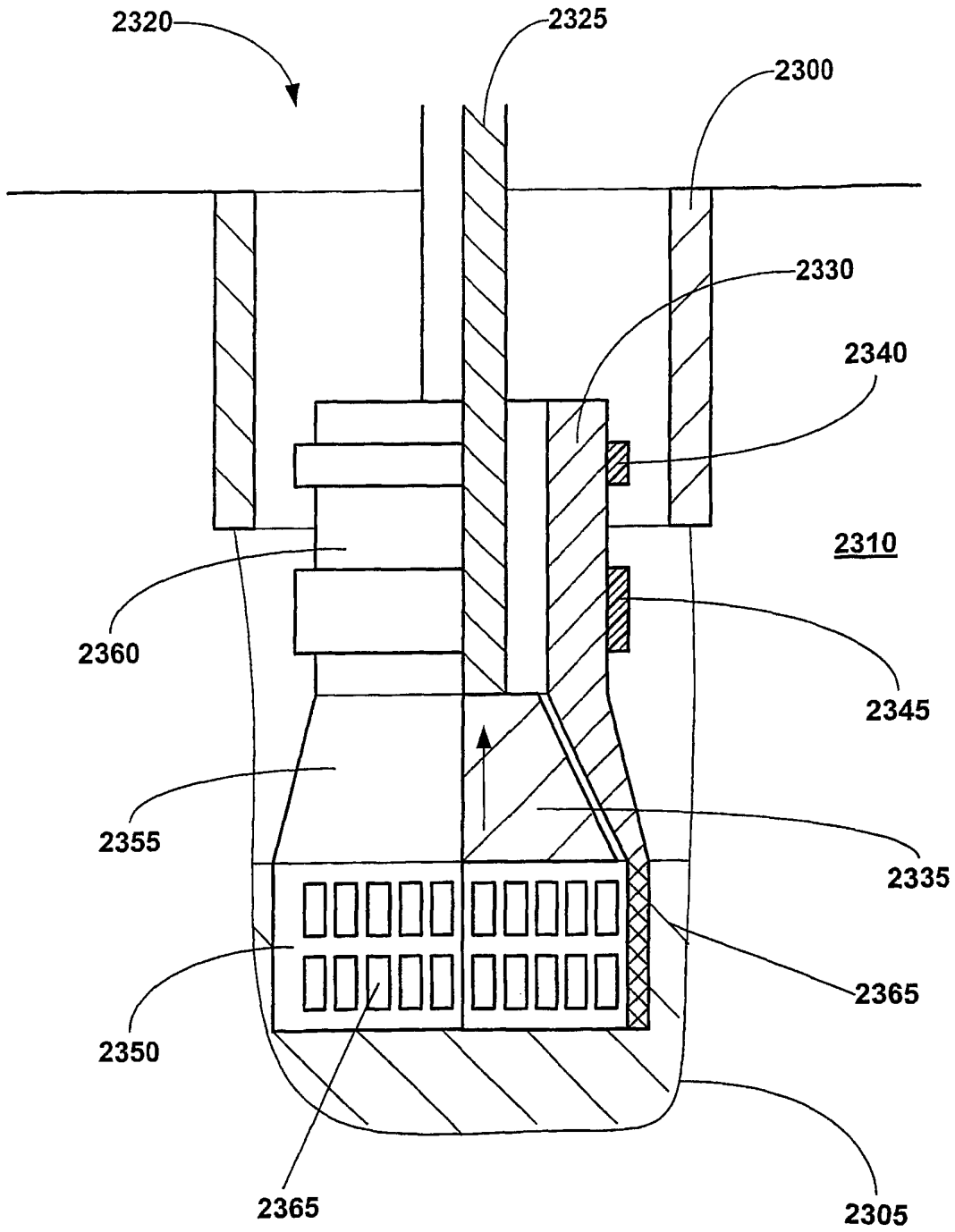

FIGURE 23d

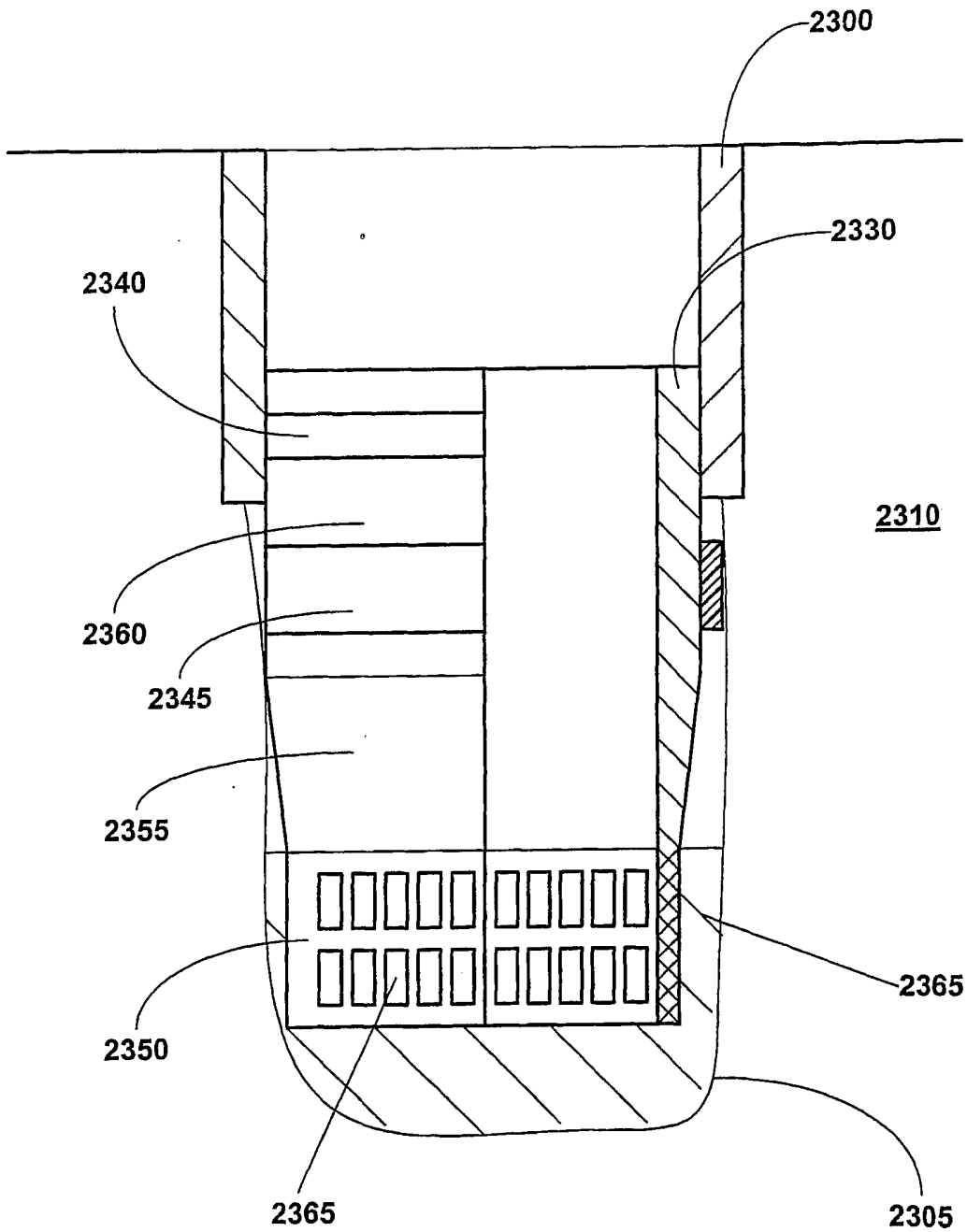

FIGURE 23e

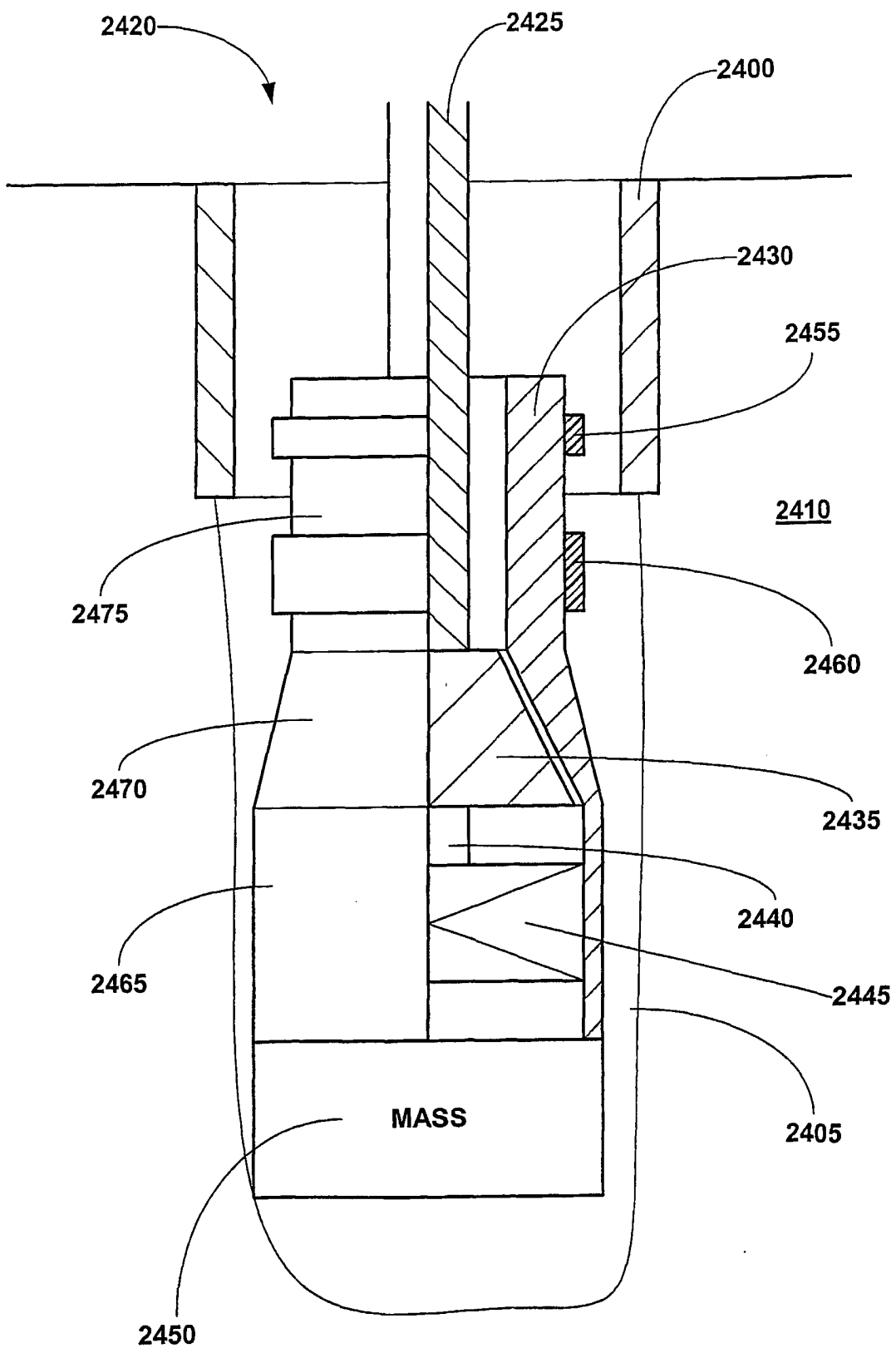

FIGURE 24a

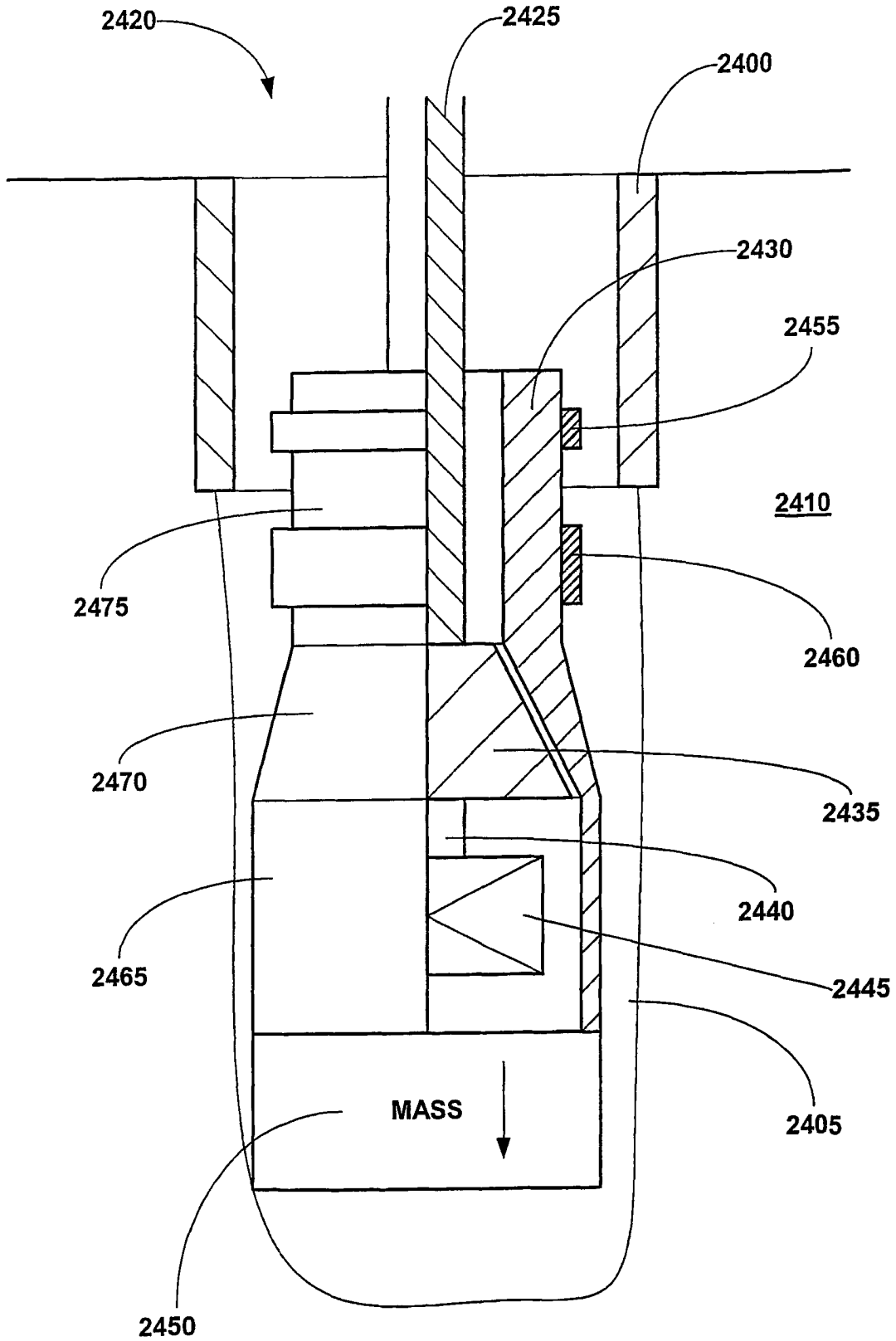

FIGURE 24b



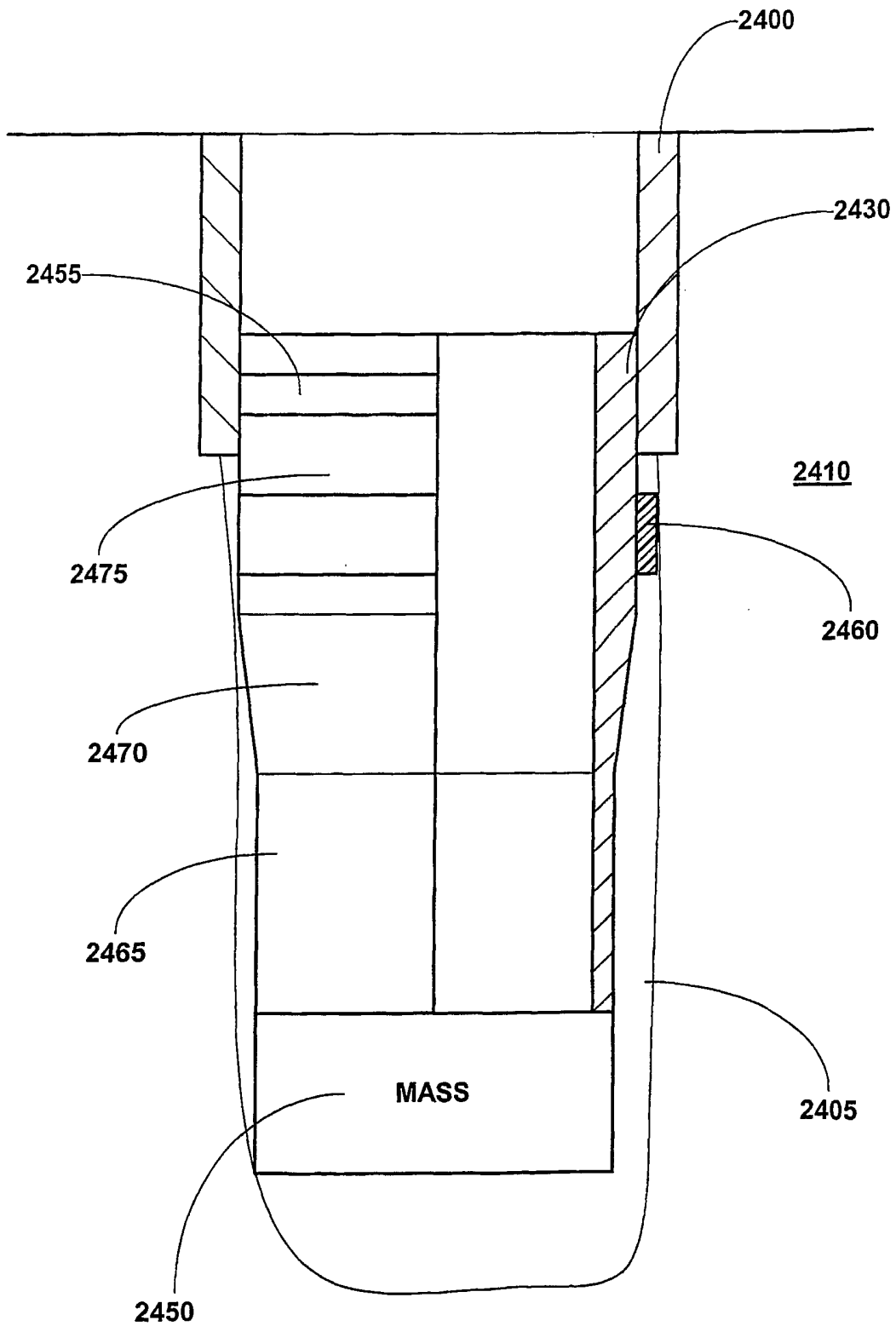

FIGURE 24c



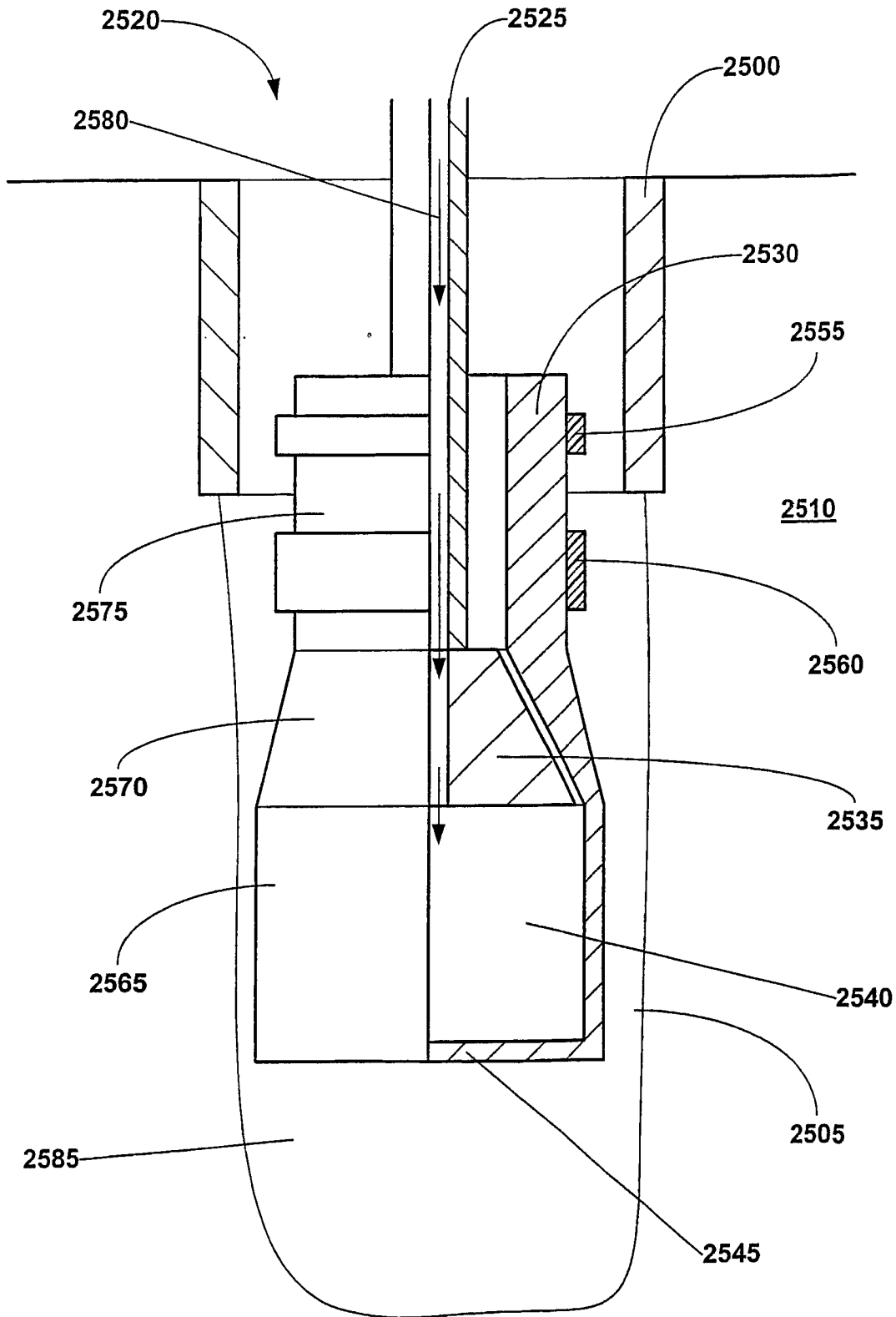

FIGURE 25b

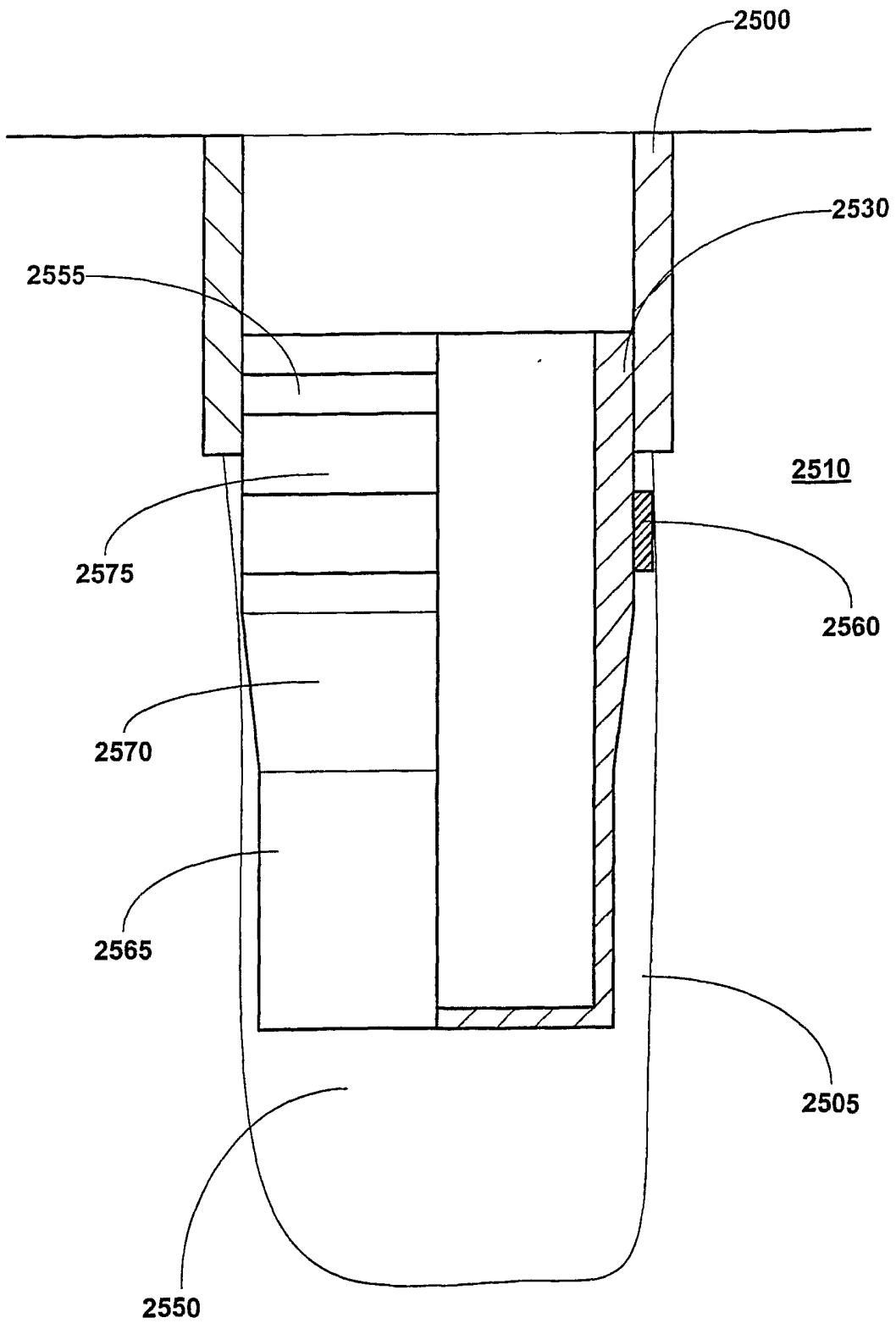

FIGURE 25c

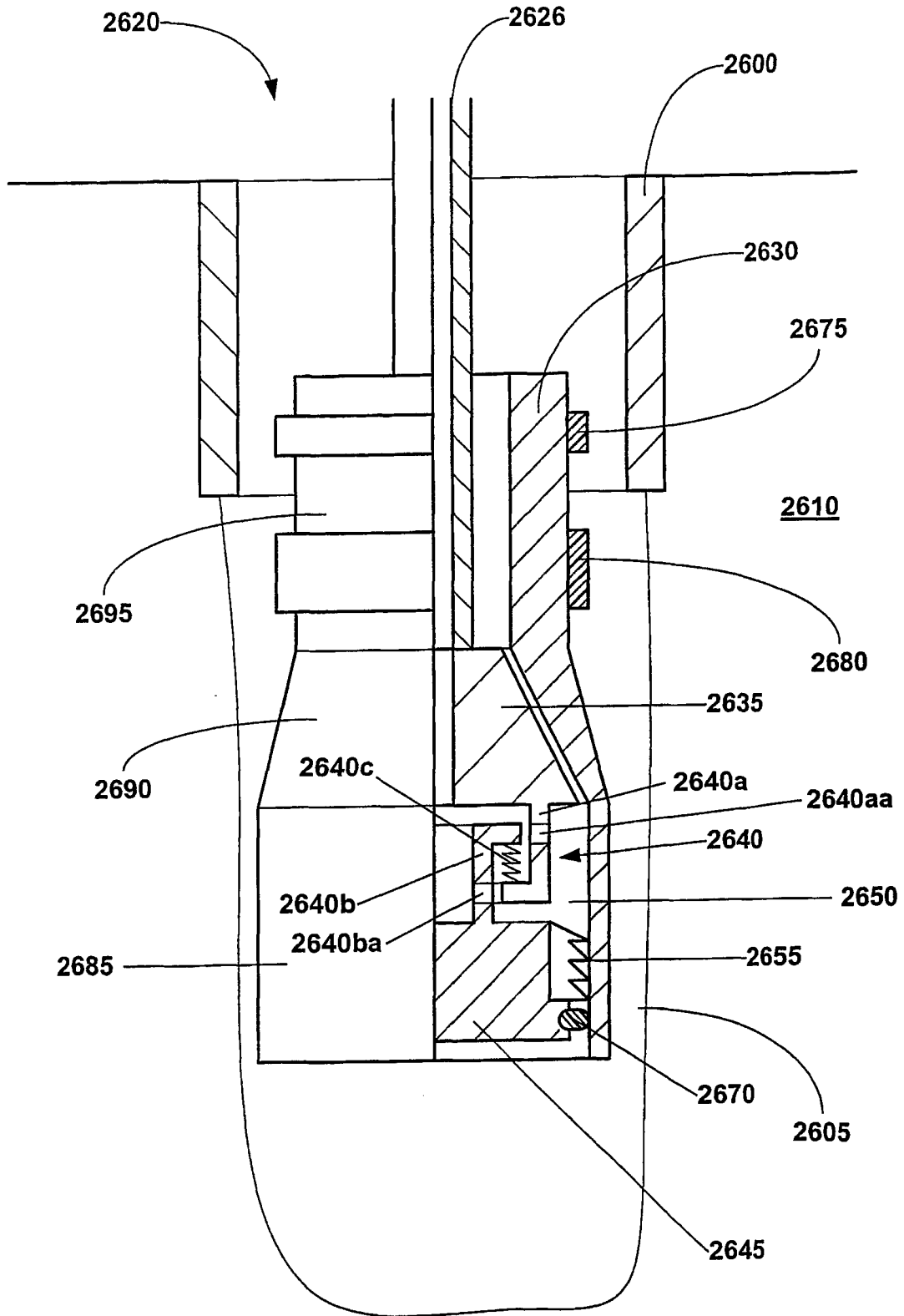

FIGURE 26a



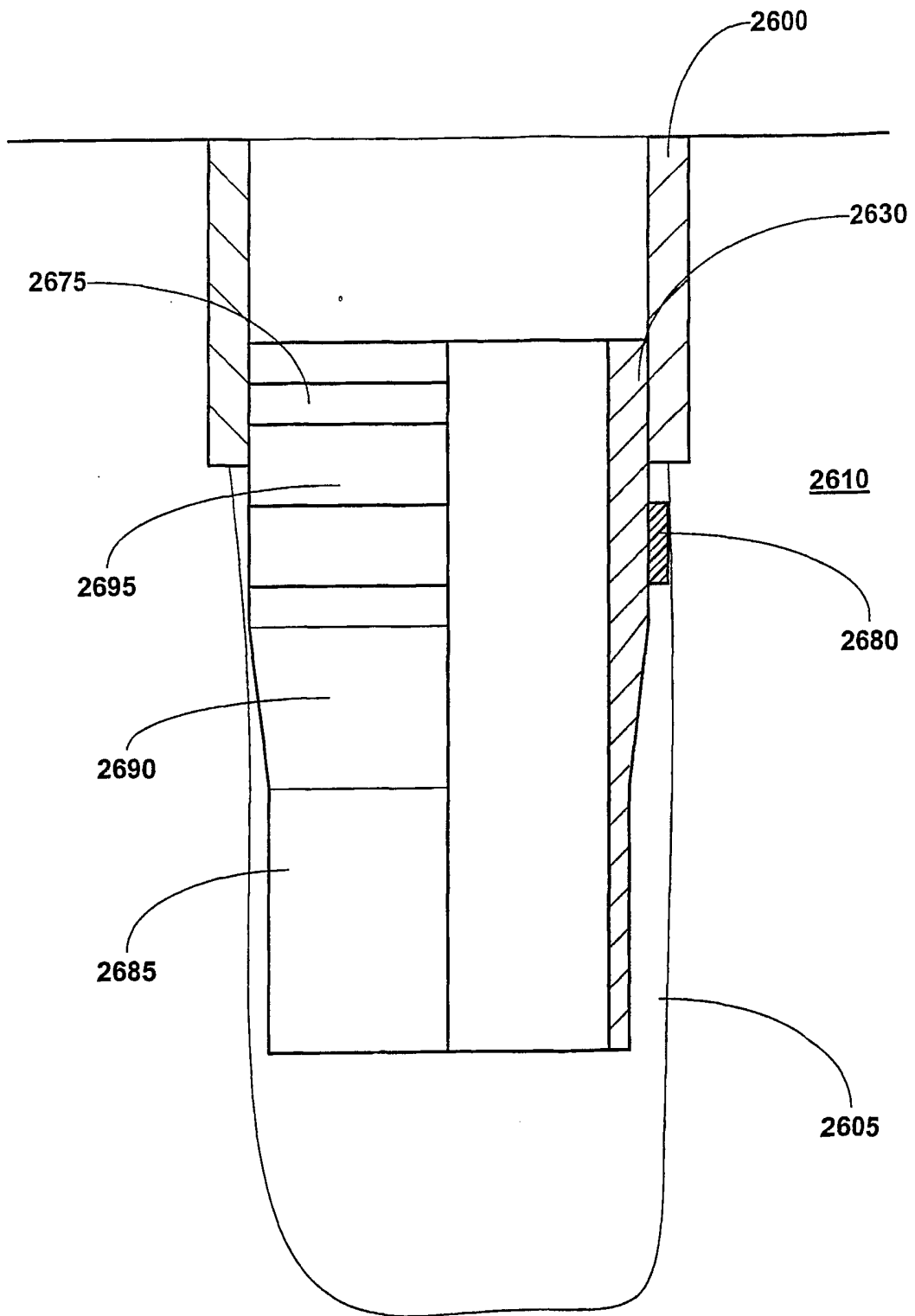

FIGURE 26c

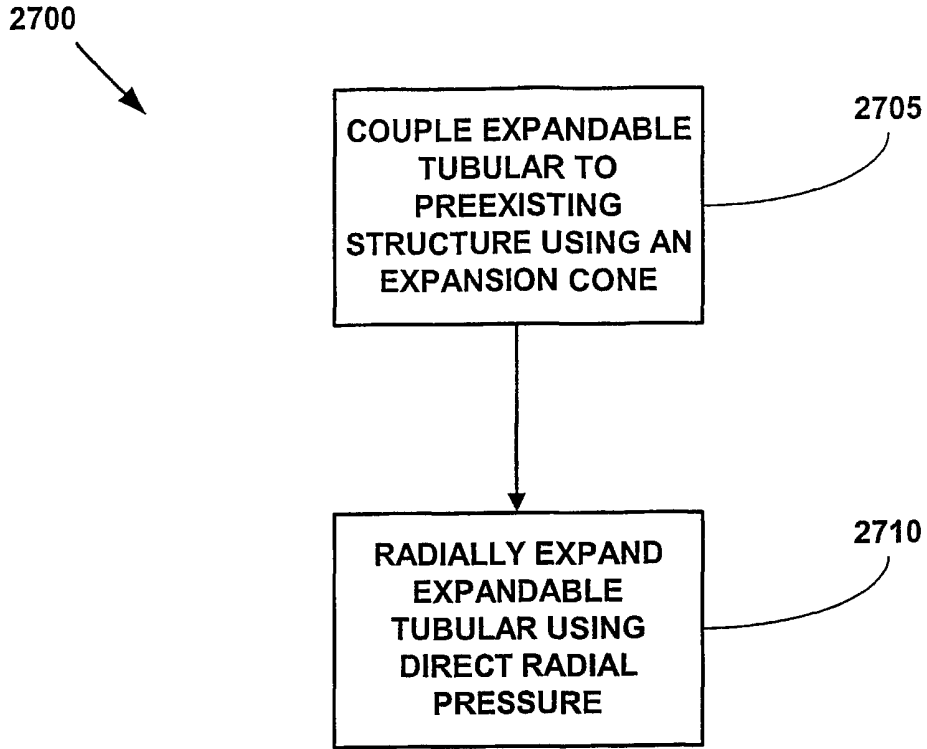
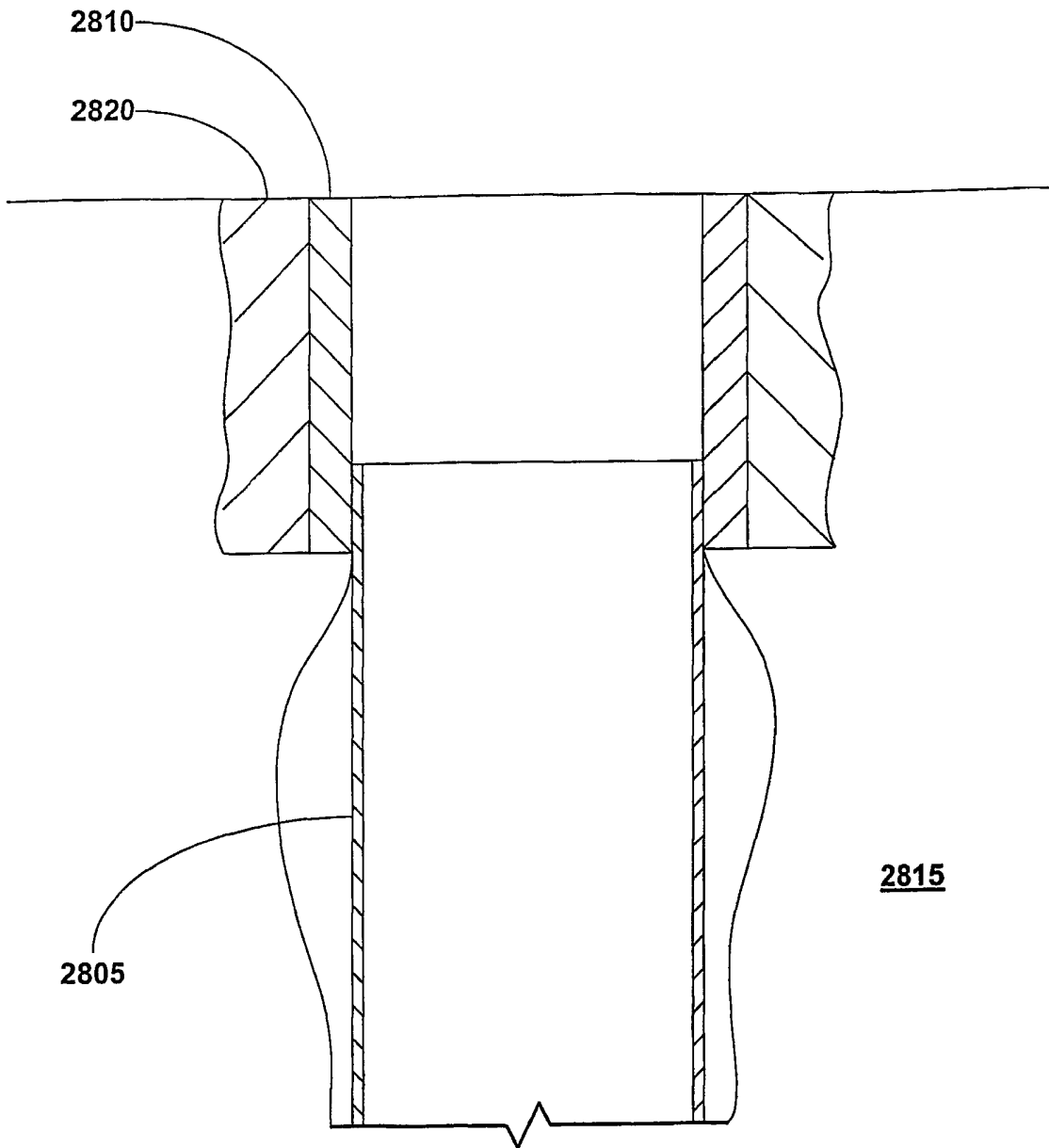

FIGURE 27





**FIGURE 28**

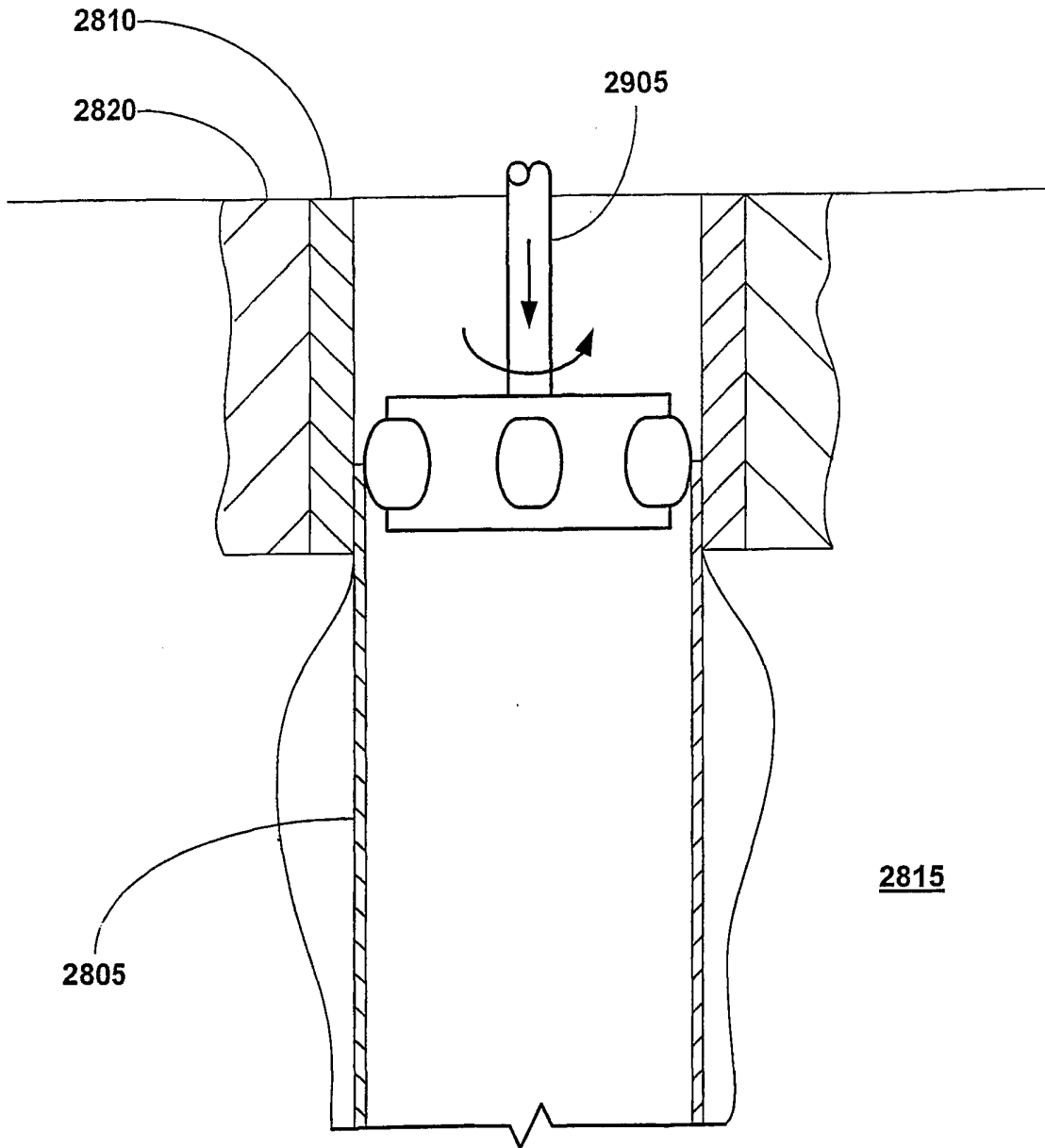

FIGURE 29

## RADIAL EXPANSION OF TUBULAR MEMBERS

## Cross Reference To Related Applications

This application claims the benefit of the filing date of U.S. provisional patent application serial number 60/212,359, attorney docket number 25791.38, filed on  
5 June 19, 2000, the disclosure of which is incorporated herein by reference,

This application is a continuation-in-part of the following co-pending patent applications: (1) U.S. utility patent application serial no. 09/454,139, attorney docket no. 25791.3.02, filed on 12/3/1999, which claimed the benefit of the filing date of U.S. provisional patent application no. 60/111,293, attorney docket no. 25791.3,  
10 filed on 12/7/1998; (2) U.S. utility patent application serial no. 09/510,913, attorney docket no. 25791.7.02, filed on 2/23/2000, which claimed the benefit of the filing date of U.S. provisional application no. 60/121,702, filed on 2/25/1999; (3) U.S. utility patent application serial no. 09/502,350, attorney docket no. 25791.8.02, filed on 2/10/2000, which claimed the benefit of the filing date of U.S. provisional  
15 application no. 60/119,611, attorney docket no. 25791.8; (4) U.S. utility patent application serial no. 09/440,338, attorney docket no. 25791.9.02, filed on 11/15/1999, which claimed the benefit of the filing date of U.S. provisional application no. 60/108,558, attorney docket no. 25791.9, filed on 11/16.1998; (5) U.S. provisional patent application no. 60/183,546, filed on 2/18/2000; (6) U.S. utility  
20 patent application no. 09/523,460, attorney docket no. 25791.11.02, filed on 3/10/2000, which claimed the benefit of the filing date of U.S. provisional application no. 60/124,042, filed on 3/11/1999; (7) U.S. utility patent application no. 09/512,895, attorney docket no. 25791.12.02, filed on 2/24/2000, which claimed the benefit of the filing dates of U.S. provisional application no. 60/121,841, attorney docket no.  
25 25791.12, filed on 2/26/1999 and U.S. provisional application no. 60/154,047, attorney docket no. 25791.29, filed on 9/16/1999; (8) U.S. utility application no. 09/511,941, attorney docket no. 25791.16.02, filed on 2/24/2000, which claimed the benefit of the filing date of U.S. provisional serial no. 60/121,907, attorney docket no. 25791.16, filed on 2/26/1999; (9) U.S. utility patent application no. 09/588,946,  
30 attorney docket no. 25791.17.02, filed on 6/7/2000, which claimed the benefit of the filing date of U.S. provisional patent application serial no. 60/137,998, attorney docket no. 25791.17, filed on 6/7/1999; and (10) U.S. utility patent application no. 09/559,122, attorney docket no. 25791.23.02, filed on 4/26/2000, which claimed the benefit of the filing date of U.S. provisional application no. 60/131,106, attorney

docket no. 25791.23, filed on 4/26/1999. Applicants incorporate by reference the disclosures of these applications.

This application is related to the following co-pending patent applications:  
5 (11) U.S. provisional application no. 60/146,203, attorney docket no. 25791.25, filed on 7/29/1999; (12) U.S. provisional application no. 60/143,039, attorney docket no. 25791.26, filed on 7/9/1999; (13) U.S. provisional patent application serial no. 60/162,671, attorney docket no. 25791.27, filed on 11/1/1999; (14) U.S. provisional application no. 60/159,039, attorney docket no. 25791.36, filed on 10/12,1999; (15) U.S. provisional patent application no. 60/159,033, attorney docket no. 25791.37,  
10 filed on 10/12/1999; and (16) U.S. provisional patent application no. 60/165,228, attorney docket no. 25791.39, filed on 11/12/1999. Applicants incorporate by reference the disclosures of these applications.

#### Background of the Invention

This invention relates generally to wellbore casings, and in particular to  
15 wellbore casings that are formed using expandable tubular members.

Conventionally, when a wellbore is created, a number of casings are installed in the borehole to prevent collapse of the borehole wall and to prevent undesired outflow of drilling fluid into the formation or inflow of fluid from the formation into the borehole. The borehole is drilled in intervals whereby a casing  
20 which is to be installed in a lower borehole interval is lowered through a previously installed casing of an upper borehole interval. As a consequence of this procedure the casing of the lower interval is of smaller diameter than the casing of the upper interval. Thus, the casings are in a nested arrangement with casing diameters decreasing in downward direction. Cement annuli are provided between the outer  
25 surfaces of the casings and the borehole wall to seal the casings from the borehole wall. As a consequence of this nested arrangement a relatively large borehole diameter is required at the upper part of the wellbore. Such a large borehole diameter involves increased costs due to heavy casing handling equipment, large drill bits and increased volumes of drilling fluid and drill cuttings. Moreover,  
30 increased drilling rig time is involved due to required cement pumping, cement hardening, required equipment changes due to large variations in hole diameters drilled in the course of the well, and the large volume of cuttings drilled and removed.

The present invention is directed to overcoming one or more of the  
35 limitations of the existing procedures for forming wellbores.

## Summary of the Invention

According to one aspect of the present invention, a method of coupling an expandable tubular member to a preexisting structure is provided that includes positioning the tubular member and an expansion cone within the preexisting  
5 structure, anchoring the tubular member to the preexisting structure, axially displacing the expansion cone relative to the tubular member by pulling the expansion cone through the tubular member, and lubricating the interface between the expansion cone and the tubular member.

According to another aspect of the present invention, a method of coupling a  
10 tubular member to a preexisting structure is provided that includes positioning the tubular member and an expansion cone within the preexisting structure, anchoring the tubular member to the preexisting structure, and axially displacing the expansion cone relative to the tubular member by pulling the expansion cone through the tubular member. The tubular member includes: an annular member, including: a  
15 wall thickness that varies less than about 8 %, a hoop yield strength that varies less than about 10 %, imperfections of less than about 8 % of the wall thickness, no failure for radial expansions of up to about 30 %, and no necking of the walls of the annular member for radial expansions of up to about 25%.

According to another aspect of the present invention, a method of coupling a  
20 tubular member to a preexisting structure is provided that includes injecting a lubricating fluid into the preexisting structure, positioning the tubular member and an expansion cone within the preexisting structure, anchoring the tubular member to the preexisting structure, and axially displacing the expansion cone relative to the tubular member by pulling the expansion cone through the tubular member.

According to another aspect of the present invention, a method of coupling  
25 an expandable tubular member to a preexisting structure is provided that includes positioning the expandable tubular member and an expansion cone within the preexisting structure, anchoring the expandable tubular member to the preexisting structure and axially displacing the expansion cone relative to the expandable  
30 tubular member by pulling the expansion cone through the expandable tubular member. The expandable tubular member includes: a first tubular member, a second tubular member, and a threaded connection for coupling the first tubular member to the second tubular member. The threaded connection includes: one or  
35 more sealing members for sealing the interface between the first and second tubular members.

According to another aspect of the present invention, a method of coupling an expandable tubular member to a preexisting structure is provided that includes positioning the expandable tubular member and an expansion cone within the preexisting structure, anchoring the expandable tubular member to the preexisting  
5 structure, and axially displacing the expansion cone relative to the expandable tubular member by pulling the expansion cone through the expandable tubular member. The expandable tubular member includes a plurality of tubular members having threaded portions that are coupled to one another by the process of: coating the threaded portions of the tubular members with a sealant, coupling the threaded  
10 portions of the tubular members and curing the sealant.

According to another aspect of the present invention, a method of coupling a tubular member to a preexisting structure is provided that includes positioning the tubular member and an expansion cone within the preexisting structure, anchoring the tubular member to the preexisting structure, and axially displacing the expansion  
15 cone relative to the tubular member by pulling the expansion cone through the expandable tubular member. The tubular member includes: a pair of rings for engaging the preexisting structure, and a sealing element positioned between the rings for sealing the interface between the tubular member and the preexisting structure.

According to another aspect of the present invention, a method of coupling a tubular member to a preexisting structure is provided that includes positioning the expandable tubular member and an expansion cone within the preexisting structure, anchoring the expandable tubular member to the preexisting structure, and axially  
20 displacing the expansion cone relative to the expandable tubular member by pulling the expansion cone through the expandable tubular member. The tubular member includes one or more slots.

According to another aspect of the present invention, a method of coupling a tubular member to a preexisting structure is provided that includes positioning the expandable tubular member and an expansion cone within the preexisting structure,  
30 anchoring the expandable tubular member to the preexisting structure, and axially displacing the expansion cone relative to the expandable tubular member by pulling the expansion cone through the expandable tubular member. The tubular member includes: a first preexpanded portion, an intermediate portion coupled to the first preexpanded portion including a sealing element, and a second preexpanded  
35 portion coupled to the intermediate portion.

According to another aspect of the present invention, a method of coupling a tubular member to a preexisting structure is provided that includes positioning the expandable tubular member and an expansion cone within the preexisting structure, anchoring the expandable tubular member to the preexisting structure, and axially displacing the expansion cone relative to the expandable tubular member by pulling the expansion cone through the expandable tubular member by applying an axial force to the expansion cone. The axial force includes: a substantially constant axial force, and an increased axial force.

According to another aspect of the present invention, a method of coupling a tubular member to a preexisting structure is provided that includes positioning the tubular member and an expansion cone within the preexisting structure, anchoring the tubular member to the preexisting structure, and axially displacing the expansion cone relative to the expandable tubular member by pushing and pulling the expansion cone through the expandable tubular member.

According to another aspect of the present invention, a method of coupling a tubular member to a preexisting structure is provided that includes positioning the tubular member and an expansion cone within the preexisting structure, anchoring the tubular member to the preexisting structure, axially displacing the expansion cone relative to the tubular member by pulling the expansion cone through the expandable tubular member, and injecting a curable fluidic sealing material between the tubular member and the preexisting structure prior to axially displacing the expansion cone.

According to another aspect of the present invention, a method of coupling a tubular member to a preexisting structure is provided that includes positioning the tubular member and an expansion cone within the preexisting structure, anchoring the tubular member to the preexisting structure by increasing the size of the expansion cone, and axially displacing the expansion cone relative to the tubular member by pulling the expansion cone through the tubular member.

According to another aspect of the present invention, a method of coupling a tubular member to a preexisting structure is provided that includes positioning the tubular member and an expansion cone within the preexisting structure, anchoring the tubular member to the preexisting structure by heating a portion of the tubular member, and axially displacing the expansion cone relative to the tubular member by pulling the expansion cone through the tubular member.

According to another aspect of the present invention, a method of coupling an expandable tubular member to a preexisting structure is provided that includes positioning the expandable tubular member, an expansion cone, and an anchoring device within the preexisting structure, positioning the anchoring device above the expansion cone, anchoring the expandable tubular member to the preexisting structure using the anchoring device, and axially displacing the expansion cone.

According to another aspect of the present invention, a method of coupling an expandable tubular member to a preexisting structure is provided that includes positioning the tubular member and an expansion cone within the preexisting structure, explosively anchoring the tubular member to the preexisting structure, and axially displacing the expansion cone relative to the tubular member.

According to another aspect of the present invention, a method of coupling an expandable tubular to a preexisting structure is provided that includes fixing the position of an expansion cone within the preexisting structure, driving the expandable tubular member onto the expansion cone in a first direction, and axially displacing the expansion cone in a second direction relative to the expandable tubular member. The first and second directions are different.

According to another aspect of the present invention, a method of coupling an expandable tubular member to a preexisting structure is provided that includes placing the expandable tubular, an expansion cone, and a resilient anchor within the preexisting structure, releasing the resilient anchor, and axially displacing the expansion cone within the expandable tubular member.

According to another aspect of the present invention, a method of coupling an expandable tubular member to a preexisting structure is provided that includes placing the expandable tubular member, an expansion cone, and an anchor into the preexisting structure, and anchoring the expandable tubular member to the preexisting structure by: pivoting one or more engagement elements, and axially displacing the expansion cone.

According to another aspect of the present invention, a method of coupling an expandable tubular member to a preexisting structure is provided that includes placing the expandable tubular member and an expansion cone into the preexisting structure, placing a quantity of a fluidic material onto the expandable tubular member to anchor the expandable tubular member to the preexisting structure, and axially displacing the expansion cone.



According to another aspect of the present invention, a method of coupling an expandable tubular member to a preexisting structure is provided that includes positioning the expandable tubular member and an expansion cone into the preexisting structure, anchoring the expandable tubular member to the preexisting  
5 structure by injecting a quantity of a hardenable fluidic material into the preexisting structure, at least partially curing the hardenable fluidic sealing material, and axially displacing the expansion cone.

According to another aspect of the present invention, a method of coupling an expandable tubular member to a preexisting structure is provided that includes  
10 placing the expandable tubular member and an expansion cone within the preexisting structure and applying an axial force to the expandable tubular member in a downward direction.

According to another aspect of the present invention, a method of coupling an expandable tubular member to a preexisting structure is provided that includes  
15 placing the expandable tubular member and an expansion cone within the preexisting structure, injecting a quantity of a first fluidic material having a first density into the region of the preexisting structure outside of the expandable tubular member, and injecting a quantity of a second fluidic material having a second density into a portion of the expandable tubular member below the expansion cone.  
20 The second density is greater than the first density.

According to another aspect of the present invention, a method of coupling an expandable tubular member to a preexisting structure is provided that includes placing the expandable tubular member and an expansion cone into the preexisting structure, anchoring the expandable tubular member to the preexisting structure,  
25 applying an axial force to the expansion cone, and pressurizing an interior portion of the expandable tubular member below the expansion cone.

According to another aspect of the present invention, a method of coupling an expandable tubular member to a preexisting structure is provided that includes placing the expandable tubular member and an expansion cone into the preexisting  
30 structure and applying an axial force to the expandable tubular member.

According to another aspect of the present invention, an apparatus for coupling a tubular member to a preexisting structure is provided that includes an expandable tubular member, an anchoring device adapted to couple the expandable tubular member to the preexisting structure, and an expansion cone movably  
35 coupled to the expandable tubular member and adapted to radially expand the

expandable tubular member, including: a housing including a tapered first end and a second end, one or more grooves formed in the outer surface of the tapered first end, and one or more axial flow passages fluidically coupled to the grooves.

5 According to another aspect of the present invention, an apparatus for coupling an expandable tubular member to a preexisting structure is provided that includes an expandable tubular member, an anchoring device adapted to couple the expandable tubular member to the preexisting structure, and an expansion cone movably coupled to the expandable tubular member and adapted to radially expand the expandable tubular member. The expandable tubular member includes: an  
10 annular member, having: a wall thickness that varies less than about 8 %, a hoop yield strength that varies less than about 10 %, imperfections of less than about 8 % of the wall thickness, no failure for radial expansions of up to about 30 %, and no necking of the walls of the annular member for radial expansions of up to about 25%.

15 According to another aspect of the present invention, an apparatus for coupling an expandable tubular member to a preexisting structure is provided that includes an expandable tubular member, an anchoring device adapted to couple the expandable tubular member to the preexisting structure, and an expansion cone movably coupled to the expandable tubular member and adapted to radially expand  
20 the expandable tubular member. The expandable tubular member includes: a first tubular member, a second tubular member, and a threaded connection for coupling the first tubular member to the second tubular member, the threaded connection including: one or more sealing members for sealing the interface between the first and second tubular members.

25 According to another aspect of the present invention, an apparatus for coupling an expandable tubular member to a preexisting structure is provided that includes an expandable tubular member, an anchoring device adapted to couple the expandable tubular member to the preexisting structure, and an expansion cone movably coupled to the expandable tubular member and adapted to radially expand  
30 the expandable tubular member. The expandable tubular member includes: a layer of a lubricant coupled to the interior surface of the tubular member.

35 According to another aspect of the present invention, an apparatus for coupling an expandable tubular member to a preexisting structure is provided that includes an expandable tubular member, an anchoring device adapted to couple the expandable tubular member to the preexisting structure, and an expansion cone

movably coupled to the expandable tubular member and adapted to radially expand the expandable tubular member. The expandable tubular member includes: a pair of tubular members having threaded portions coupled to one another, and a quantity of a sealant within the threaded portions of the tubular members.

5           According to another aspect of the present invention, an apparatus for coupling an expandable tubular member to a preexisting structure is provided that includes an expandable tubular member, an anchoring device adapted to couple the expandable tubular member to the preexisting structure, and an expansion cone movably coupled to the expandable tubular member and adapted to radially expand  
10 the expandable tubular member. The expandable tubular member includes: a pair of rings for engaging the preexisting structure, and a sealing element positioned between the rings for sealing the interface between the tubular member and the preexisting structure.

          According to another aspect of the present invention, an apparatus for  
15 coupling an expandable tubular member to a preexisting structure is provided that includes an expandable tubular member, an anchoring device adapted to couple the expandable tubular member to the preexisting structure, and an expansion cone movably coupled to the expandable tubular member and adapted to radially expand the expandable tubular member. The expandable tubular member includes one or  
20 more slots.

          According to another aspect of the present invention, an apparatus for  
coupling an expandable tubular member to a preexisting structure is provided that  
includes an expandable tubular member, an anchoring device adapted to couple the  
expandable tubular member to the preexisting structure, and an expansion cone  
25 movably coupled to the expandable tubular member and adapted to radially expand the expandable tubular member. The expandable tubular member includes: a first preexpanded portion, an intermediate portion coupled to the first preexpanded portion including a sealing element, and a second preexpanded portion coupled to the intermediate portion.

30           According to another aspect of the present invention, an apparatus for coupling an expandable tubular member to a preexisting structure is provided that includes an expandable tubular member, an anchoring device adapted to couple the expandable tubular member to the preexisting structure, an expansion cone movably coupled to the expandable tubular member and adapted to radially expand

the expandable tubular member, and a valveable fluid passage coupled to the anchoring device.

According to another aspect of the present invention, an apparatus for coupling an expandable tubular member to a preexisting structure is provided that includes a first support member, a second support member coupled to the first support member, an expansion cone coupled to the first support member, an expandable tubular member coupled to the expansion cone, and an anchoring device coupled to the second support member adapted to couple the expandable tubular member to the preexisting structure. The anchoring device is positioned above the expansion cone.

According to another aspect of the present invention, an apparatus for coupling an expandable tubular member to a preexisting structure is provided that includes a first support member, a second support member coupled to the first support member, an expansion cone coupled to the first support member, an expandable tubular member coupled to the expansion cone, and an explosive anchoring device coupled to the second support member adapted to couple the expandable tubular member to the preexisting structure.

According to another aspect of the present invention, an apparatus for coupling an expandable tubular member to a preexisting structure is provided that includes a support member, an expandable expansion cone coupled to the support member, and an expandable tubular member coupled to the expansion cone.

According to another aspect of the present invention, an apparatus for coupling an expandable tubular member to a preexisting structure is provided that includes a support member, an expandable expansion cone coupled to the support member, and an expandable tubular member coupled to the expandable expansion cone.

According to another aspect of the present invention, an apparatus for coupling an expandable tubular to a preexisting structure is provided that includes a support member, an expansion cone coupled to the support member, an expandable tubular member coupled to the expansion cone including one or more shape memory metal inserts, and a heater coupled to the support member in opposing relation to the shape memory metal inserts.

According to another aspect of the present invention, an apparatus for coupling an expandable tubular member to a preexisting structure is provided that includes a support member, an expansion cone coupled to the support member, an

expandable tubular member coupled to the expandable expansion cone, and a resilient anchor coupled to the expandable tubular member.

According to another aspect of the present invention, an expandable tubular member is provided that includes: an expandable tubular body, one or more resilient panels coupled to the expandable tubular body, and a release member releasably coupled to the resilient panels adapted to controllably release the resilient panels.

According to another aspect of the present invention, an apparatus for coupling an expandable tubular member to a preexisting structure is provided that includes a support member, an expansion cone coupled to the support member, an expandable tubular member coupled to the expandable expansion cone, and an anchor coupled to the expandable tubular member, including: one or more spikes pivotally coupled to the expandable tubular member for engaging the preexisting structure.

According to another aspect of the present invention, an apparatus for coupling an expandable tubular member to a preexisting structure is provided that includes a support member, an expansion cone coupled to the support member, an expandable tubular member coupled to the expandable expansion cone, and an anchor coupled to the expandable tubular member, including: one or more petal baskets pivotally coupled to the expandable tubular member.

According to another aspect of the present invention, an apparatus for coupling an expandable tubular member to a preexisting structure is provided that includes a support member, an expansion cone coupled to the support member, an expandable tubular member coupled to the expansion cone, including: a slotted portion provided at one end of the expandable tubular member.

According to another aspect of the present invention, an apparatus for coupling an expandable tubular member to a preexisting structure is provided that includes a support member, an expansion cone, an expandable tubular member coupled to the expansion cone, a coupling device coupled to the support member and an end portion of the expandable tubular member, and a mass coupled to the end portion of the expandable tubular member. The weight of the mass is greater than the yield strength of the expandable tubular member.

According to another aspect of the present invention, an apparatus for coupling an expandable tubular member to a preexisting structure is provided that includes a support member including a fluid passage, an expansion cone coupled to the support member, an expandable tubular member coupled to the expansion

cone, a slip joint coupled to the expansion cone, an end plate coupled to the slip joint, a fluid chamber coupled to the fluid passage, the fluid chamber defined by the interior portion of the expandable tubular member between the expansion cone and the end plate.

5           According to another aspect of the present invention, a method of coupling a tubular member to a preexisting structure is provided that includes positioning the tubular member and an expansion cone within the preexisting structure, axially displacing the expansion cone, removing the expansion cone, and applying direct radial pressure to the tubular member.

10           According to another aspect of the present invention, an apparatus is provided that includes a tubular member coupled to a preexisting structure. The tubular member is coupled to the preexisting structure by the process of: positioning the tubular member and an expansion cone within the preexisting structure, axially displacing the expansion cone, removing the expansion cone, and  
15           applying direct radial pressure to the tubular member.

#### Brief Description of the Drawings

FIG. 1a is a fragmentary cross-sectional illustration of the placement of an embodiment of an apparatus for expanding a tubular member within a wellbore casing.

20           FIG. 1b is a fragmentary cross-sectional illustration of the apparatus of FIG. 1a after anchoring the expandable tubular member of the apparatus to the wellbore casing.

FIG. 1c is a fragmentary cross-sectional illustration of the apparatus of FIG. 1b after initiating the axial displacement of the expansion cone.

25           FIG. 1d is a fragmentary cross-sectional illustration of the apparatus of FIG. 1b after initiating the axial displacement of the expansion cone by pulling on the expansion cone and injecting a pressurized fluid below the expansion cone.

30           FIG. 1e is a fragmentary cross-sectional illustration of the apparatus of FIGS. 1c and 1d after the completion of the radial expansion of the expandable tubular member.

FIG. 1f is a fragmentary cross-sectional illustration of the apparatus of FIG. 1e after the decoupling of the anchoring device of the apparatus from the wellbore casing.

FIG. 1g is a fragmentary cross-sectional illustration of the apparatus of FIG. 1f after the removal of the anchoring device of the apparatus from the wellbore casing.

5 FIG. 2a is a fragmentary cross-sectional illustration of the placement of an embodiment of an apparatus for expanding a tubular member within a wellbore casing and an open hole in a subterranean formation.

FIG. 2b is a fragmentary cross-sectional illustration of the apparatus of FIG. 2a after anchoring the expandable tubular member of the apparatus to the open hole.

10 FIG. 2c is a fragmentary cross-sectional illustration of the apparatus of FIG. 2b after initiating the axial displacement of the expansion cone.

FIG. 2d is a fragmentary cross-sectional illustration of the apparatus of FIG. 2b after initiating the axial displacement of the expansion cone by pulling on the expansion cone and also by injecting a pressurized fluid below the expansion cone.

15 FIG. 2e is a fragmentary cross-sectional illustration of the apparatus of FIGS. 2c and 2d after the completion of the radial expansion of the expandable tubular member.

FIG. 2f is a fragmentary cross-sectional illustration of the apparatus of FIG. 2e after the decoupling of the anchoring device of the apparatus from the open hole.

20 FIG. 3a is a fragmentary cross-sectional illustration of the placement of an embodiment of an apparatus for expanding a tubular member within a wellbore casing.

FIG. 3b is a fragmentary cross-sectional illustration of the apparatus of FIG. 3a after anchoring the expandable tubular member of the apparatus to the wellbore casing.

25 FIG. 3c is a fragmentary cross-sectional illustration of the apparatus of FIG. 3b after initiating the axial displacement of the expansion cone.

FIG. 3d is a fragmentary cross-sectional illustration of the apparatus of FIG. 3c after completing the radial expansion of the expandable tubular member.

30 FIG. 4 is a fragmentary cross-sectional illustration of an embodiment of a shock absorbing system for use in the apparatus of FIGS. 1a to 3d.

FIG. 5 is a cross-sectional illustration of an embodiment of a coupling arrangement for use in the expandable tubular members of the apparatus of FIGS. 1a to 3d.

FIG. 6 is a cross-sectional illustration of an embodiment of an expandable tubular member having a slotted lower section for use in the apparatus of FIGS. 1a to 3d.

5 FIG. 7 is a cross-sectional illustration of an embodiment of an expandable tubular member having a pre-expanded upper portion for use in the apparatus of FIGS. 1a to 3d.

FIG. 8 is a cross-sectional illustration of an embodiment of an expandable tubular member having a slotted upper section for use in the apparatus of FIGS. 1a to 3d.

10 FIG. 9 is a graphical illustration of an embodiment of a method of applying an axial force to the expansion cones of the apparatus of FIGS. 1a to 3d.

FIG. 10a is a fragmentary cross-sectional illustration of the placement of an embodiment of an apparatus for expanding a tubular member within a wellbore casing.

15 FIG. 10b is a fragmentary cross-sectional illustration of the apparatus of FIG. 10a during the injection of a non-hardenable fluidic material into and out of the apparatus.

20 FIG. 10c is a fragmentary cross-sectional illustration of the apparatus of FIG. 10b during the injection of a hardenable fluidic sealing material into and out of the apparatus.

FIG. 10d is a fragmentary cross-sectional illustration of the apparatus of FIG. 10c after the placement of a valve closure element into the valve passage of the anchoring device of the apparatus.

25 FIG. 10e is a fragmentary cross-sectional illustration of the apparatus of FIG. 10d after anchoring the expandable tubular member of the apparatus to the wellbore casing.

FIG. 10f is a fragmentary cross-sectional illustration of the apparatus of FIG. 10e after initiating the axial displacement of the expansion cone.

30 FIG. 10g is a fragmentary cross-sectional illustration of the apparatus of FIG. 10e after initiating the axial displacement of the expansion cone by pulling on the expansion cone and injecting a pressurized fluid below the expansion cone.

FIG. 10h is a fragmentary cross-sectional illustration of the apparatus of FIGS. 10f and 10g after the completion of the radial expansion of the expandable tubular member.



FIG. 10i is a fragmentary cross-sectional illustration of the apparatus of FIG. 10h after the decoupling and removal of the anchoring device of the apparatus from the wellbore casing.

5 FIG. 11a is a fragmentary cross-sectional illustration of an alternative embodiment of an apparatus for coupling an expandable tubular member to a preexisting structure.

FIG. 11b is a fragmentary cross-sectional illustration of the apparatus of FIG. 11a after anchoring the expandable tubular member of the apparatus to the wellbore casing.

10 FIG. 11c is a fragmentary cross-sectional illustration of the apparatus of FIG. 11b after initiating the axial displacement of the expansion cone.

FIG. 11d is a fragmentary cross-sectional illustration of the apparatus of FIG. 11c after stopping the axial displacement of the expansion cone prior to deactivating the anchoring device.

15 FIG. 11e is a fragmentary cross-sectional illustration of the apparatus of FIGS. 11d after deactivating the anchoring device.

FIG. 11f is a fragmentary cross-sectional illustration of the apparatus of FIG. 11e after initiating the axial displacement of the expansion cone and the deactivated anchoring device.

20 FIG. 11g is a fragmentary cross-sectional illustration of the apparatus of FIG. 11f after the completion of the radial expansion of the expandable tubular member.

FIG. 12a is a fragmentary cross-sectional illustration of an alternative embodiment of an apparatus for coupling an expandable tubular member to a preexisting structure positioned within a wellbore.

25 FIG. 12b is a fragmentary cross-sectional illustration of the apparatus of FIG. 12a after expanding the expandable expansion cone in order to anchor the expandable tubular member to the wellbore casing.

FIG. 12c is a fragmentary cross-sectional illustration of the apparatus of FIG. 12b after initiating the axial displacement of the expandable expansion cone.

30 FIG. 12d is a fragmentary cross-sectional illustration of the apparatus of FIG. 12c after completing the radial expansion of the expandable tubular member.

FIG 13a is a fragmentary cross-sectional illustration of an alternative embodiment of an apparatus for coupling an expandable tubular member to a preexisting structure positioned within a wellbore.

FIG. 13b is a fragmentary cross-sectional illustration of the apparatus of FIG. 13a after activating the shape memory metal inserts in order to anchor the expandable tubular member to the wellbore casing.

5 FIG. 13c is a fragmentary cross-sectional illustration of the apparatus of FIG. 13b after initiating the axial displacement of the expansion cone.

FIG. 13d is a fragmentary cross-sectional illustration of the apparatus of FIG. 13c after completing the radial expansion of the expandable tubular member.

10 FIG. 14a is a fragmentary cross-sectional illustration of an alternative embodiment of an apparatus for coupling an expandable tubular member to a preexisting structure positioned within a wellbore casing.

FIG. 14b is a fragmentary cross-sectional illustration of the apparatus of FIG. 14a after coupling the packer to the wellbore casing.

15 FIG. 14c is a fragmentary cross-sectional illustration of the apparatus of FIG. 14b after initiating the axial displacement of the expandable tubular member towards the expansion cone.

FIG. 14d is a fragmentary cross-sectional illustration of the apparatus of FIG. 14c after radially expanding the end of the expandable tubular member onto the expansion cone.

20 FIG. 14e is a fragmentary cross-sectional illustration of the apparatus of FIG. 14d after decoupling the packer from the wellbore casing.

FIG. 14f is a fragmentary cross-sectional illustration of the apparatus of FIG. 14e after initiating the axial displacement of the expansion cone relative to the expandable tubular member.

25 FIG. 14g is a fragmentary cross-sectional illustration of the completion of the radial expansion of the expandable tubular member.

FIG. 15a is a fragmentary cross-sectional illustration of an alternative embodiment of an apparatus for coupling an expandable tubular member to a preexisting structure positioned within a wellbore.

30 FIG. 15b is a fragmentary cross-sectional illustration of the apparatus of FIG. 15a after coupling the resilient anchor to the wellbore casing.

FIG. 15c is a fragmentary cross-sectional illustration of the apparatus of FIG. 15b after initiating the axial displacement of the expansion cone.

FIG. 15d is a fragmentary cross-sectional illustration of the apparatus of FIG. 15c after completion of the radial expansion of the expandable tubular member.

FIG. 16a is a top view of an embodiment of a resilient anchor for use in the apparatus of FIG. 15a.

FIG. 16b is a top view of the resilient anchor of FIG. 16a after releasing the coiled resilient member.

5 FIG. 17a is a top view of an alternate embodiment of a resilient anchor for use in the apparatus of FIG. 15a.

FIG. 17b is a top view of the resilient anchor of FIG. 17a after releasing the resilient elements.

10 FIG. 18a is a fragmentary cross-sectional top view of an alternate embodiment of a resilient anchor for use in the apparatus of FIG. 15a.

FIG. 18b is a fragmentary cross-sectional top view of the resilient anchor of FIG. 18a after releasing the resilient elements.

FIG. 19a is an front view of an embodiment of an expandable tubular member including one or more resilient panels.

15 FIG. 19b is a cross-sectional view of the expandable tubular member of FIG. 19a.

FIG. 19c is a bottom view of the expandable tubular member of FIG. 19a.

20 FIG. 20a is a fragmentary cross-sectional illustration of an alternative embodiment of an apparatus for coupling an expandable tubular member to a preexisting structure positioned within a wellbore.

FIG. 20b is a fragmentary cross-sectional illustration of the apparatus of FIG. 20a after coupling the anchor to the wellbore casing.

FIG. 20c is a fragmentary cross-sectional illustration of the apparatus of FIG. 20b after initiating the axial displacement of the expansion cone.

25 FIG. 20d is a fragmentary cross-sectional illustration of the apparatus of FIG. 20c after completion of the radial expansion of the expandable tubular member.

FIG. 21a is an illustration of an embodiment of the anchor of the apparatus of FIG. 20a.

30 FIG. 21b is an illustration of the anchor of FIG. 21a after outwardly extending the spikes.

FIG. 22a is an illustration of an alternative embodiment of the anchor of the apparatus of FIG. 20a.

FIG. 22b is an illustration of the anchor of FIG. 22a after outwardly extending the spikes.

FIG. 22c is a cross-sectional illustration of the petals of the anchor of FIG. 22a.

FIG. 23a is a fragmentary cross-sectional illustration of an alternative embodiment of an apparatus for coupling an expandable tubular member to a preexisting structure positioned within a wellbore.

FIG. 23b is a fragmentary cross-sectional illustration of the apparatus of FIG. 20a after injecting a quantity of a hardenable fluidic sealing material into the open hole wellbore section proximate the lower section of the expandable tubular member.

FIG. 23c is a fragmentary cross-sectional illustration of the apparatus of FIG. 23b after permitting the hardenable fluidic sealing material to at least partially cure.

FIG. 23d is a fragmentary cross-sectional illustration of the apparatus of FIG. 23c after initiating the axial displacement of the expansion cone.

FIG. 23e is a fragmentary cross-sectional illustration of the apparatus of FIG. 23d after completion of the radial expansion of the expandable tubular member.

FIG. 24a is a fragmentary cross-sectional illustration of an alternative embodiment of an apparatus and method for coupling an expandable tubular member to a preexisting structure positioned within a wellbore casing and an open hole wellbore section.

FIG. 24b is a fragmentary cross-sectional illustration of the apparatus of FIG. 24a after releasing the packer.

FIG. 24c is a fragmentary cross-sectional illustration of the apparatus of FIG. 24b after extruding the expandable tubular member off of the expansion cone.

FIG. 25a is a fragmentary cross-sectional illustration of an alternative embodiment of an apparatus and method for coupling an expandable tubular member to a preexisting structure positioned within a wellbore casing and an open hole wellbore section.

FIG. 25b is a fragmentary cross-sectional illustration of the apparatus of FIG. 25a after injecting a quantity of a fluidic material into the expandable tubular member having a higher density than the fluid within the preexisting structure outside of the expandable tubular member.

FIG. 25c is a fragmentary cross-sectional illustration of the apparatus of FIG. 25b after extruding the expandable tubular member off of the expansion cone.

FIG. 26a is a fragmentary cross-sectional illustration of an alternative embodiment of an apparatus and method for coupling an expandable tubular member to a preexisting structure.

5 FIG. 26b is a fragmentary cross-sectional illustration of the apparatus of FIG. 26a after the initiation of the radial expansion process.

FIG. 26c is a fragmentary cross-sectional illustration of the completion of the radial expansion process using the apparatus of FIG. 26b.

FIG. 27 is a flow chart illustration of a preferred embodiment of a method of coupling an expandable tubular to a preexisting structure.

10 FIG. 28 is a cross-sectional illustration of an expandable tubular coupled to a preexisting structure using an expansion cone.

FIG. 29 is a cross-sectional illustration of the subsequent application of radial pressure to the expandable tubular member of FIG. 28.

#### Detailed Description

15 A method and apparatus for coupling tubular members to a preexisting structure is provided. In a preferred embodiment, the tubular members are coupled to the preexisting structure by radially expanding the tubular members into contact with the preexisting structure. In a preferred embodiment, the tubular members are radially expanded by anchoring one end of the tubular members to the preexisting  
20 structure and then pulling an expansion cone through the tubular members. In this manner, the tubular members are radially expanded and coupled to the preexisting structure.

Referring initially to FIGS, 1a, 1b, 1c, 1d, 1e, 1f and 1g, a preferred embodiment of a method and apparatus for coupling an expandable tubular member  
25 to a preexisting structure will be described. Referring to Fig. 1a, a wellbore casing 100 is positioned within a subterranean formation 105. The wellbore casing 100 may be positioned in any orientation from the vertical direction to the horizontal direction. The wellbore casing 100 further includes one or more openings 110 that may have been the result of unintentional damage to the wellbore casing 100, or  
30 due to a prior perforation or fracturing operation performed upon the surrounding subterranean formation 105. As will be recognized by persons having ordinary skill in the art, the openings 110 can adversely affect the subsequent operation and use of the wellbore casing 100 unless they are sealed off.

In a preferred embodiment, an apparatus 115 is utilized to seal off the  
35 openings 110 in the wellbore casing 100. More generally, the apparatus 115 is

preferably utilized to form or repair wellbore casings, pipelines, or structural supports.

The apparatus 115 preferably includes a first support member 120, a second support member 125, an expansion cone 130, an anchoring device 135, and expandable tubular member 140, and one or more sealing members 145.

The first support member 120 is preferably adapted to be coupled to a surface location. The first support member 120 is further coupled to the anchoring device 135. The first support member 120 is preferably adapted to convey pressurized fluidic materials and/or electrical current and/or communication signals from a surface location to the anchoring device 135. The first support member 120 may, for example, be conventional commercially available slick wire, braided wire, coiled tubing, or drilling stock material.

The second support member 125 is preferably adapted to be coupled to a surface location. The second support member 125 is further coupled to the expansion cone 130. The second support member 125 is preferably adapted to permit the expansion cone 130 to be axially displaced relative to the first support member 120. The second support member 125 may, for example, be conventional commercially available slick wire, braided wire, coiled tubing, or drilling stock material.

The expansion cone 130 is coupled to the second support member 125. The expansion cone 130 is preferably adapted to radially expand the expandable tubular member 140 when the expansion cone 130 is axially displaced relative to the expandable tubular member 140. In a preferred embodiment, the expansion cone 130 is provided substantially as disclosed in one or more of the following: (1) U.S. utility patent application serial no. 09/454,139, attorney docket no. 25791.3.02, filed on 12/3/1999, which claimed the benefit of the filing date of U.S. provisional patent application no. 60/111,293, attorney docket no. 25791.3, filed on 12/7/1998; (2) U.S. utility patent application serial no. 09/510,913, attorney docket no. 25791.7.02, filed on 2/23/2000, which claimed the benefit of the filing date of U.S. provisional application no. 60/121,702, filed on 2/25/1999; (3) U.S. utility patent application serial no. 09/502,350, attorney docket no. 25791.8.02, filed on 2/10/2000, which claimed the benefit of the filing date of U.S. provisional application no. 60/119,611, attorney docket no. 25791.8; (4) U.S. utility patent application serial no. 09/440,338, attorney docket no. 25791.9.02, filed on 11/15/1999, which claimed the benefit of the filing date of U.S. provisional application no. 60/108,558, attorney docket no.

25791.9, filed on 11/16/1998; (5) U.S. provisional patent application no. 60/183,546, filed on 2/18/2000; (6) U.S. utility patent application no. 09/523,460, attorney docket no. 25791.11.02, filed on 3/10/2000, which claimed the benefit of the filing date of U.S. provisional application no. 60/124,042, filed on 3/11/1999; (7) U.S. utility patent  
5 application no. 09/512,895, attorney docket no. 25791.12.02, filed on 2/24/2000, which claimed the benefit of the filing dates of U.S. provisional application no. 60/121,841, attorney docket no. 25791.12, filed on 2/26/1999 and U.S. provisional application no. 60/154,047, attorney docket no. 25791.29, filed on 9/16/1999; (8) U.S. utility application no. 09/511,941, attorney docket no. 25791.16.02, filed on  
10 2/24/2000, which claimed the benefit of the filing date of U.S. provisional serial no. 60/121,907, attorney docket no. 25791.16, filed on 2/26/1999; (9) U.S. utility patent application no. 09/588,946, attorney docket no. 25791.17.02, filed on June 7, 2000, which claimed the benefit of the filing date of U.S. provisional patent application serial no. 60/137,998, attorney docket no. 25791.17, filed on 6/7/1999; (10) U.S.  
15 utility patent application no. 09/559,122, attorney docket no. 25791.23.02, filed on 4/26/2000, which claimed the benefit of the filing date of U.S. provisional application no. 60/131,106, attorney docket no. 25791.23, filed on 4/26/1999; (11) U.S. provisional application no. 60/146,203, attorney docket no. 25791.25, filed on 7/29/1999; (12) U.S. provisional application no. 60/143,039, attorney docket no.  
20 25791.26, filed on 7/9/1999; (13) U.S. provisional patent application serial no. 60/162,671, attorney docket no. 25791.27, filed on 11/1/1999; (14) U.S. provisional application no. 60/159,039, attorney docket no. 25791.36, filed on 10/12/1999; (15) U.S. provisional patent application no. 60/159,033, attorney docket no. 25791.37, filed on 10/12/1999; and (16) U.S. provisional patent application no. 60/165,228,  
25 attorney docket no. 25791.39, filed on 11/12/1999, the disclosures of which are incorporated herein by reference.

The anchoring device 135 is coupled to the first support member 120. The anchoring device 135 is preferably adapted to be controllably coupled to the expandable tubular member 140 and the wellbore casing 100. In this manner, the  
30 anchoring device 135 preferably controllably anchors the expandable tubular member 140 to the wellbore casing 100 to facilitate the radial expansion of the expandable tubular member 140 by the axial displacement of the expansion cone 130. In a preferred embodiment, the anchoring device 135 includes one or more expandable elements 150 that are adapted to controllably extend from the body of  
35 the anchoring device 135 to engage both the expandable tubular member 140 and

the wellbore casing 100. In a preferred embodiment, the expandable elements 150 are actuated using fluidic pressure. In a preferred embodiment, the anchoring device 135 is any one of the hydraulically actuated packers commercially available from Halliburton Energy Services or Baker-Hughes.

5           The expandable tubular member 140 is removably coupled to the expansion cone 130. The expandable tubular member 140 is further preferably adapted to be removably coupled to the expandable element 150 of the anchoring device 135. In a preferred embodiment, the expandable tubular member 140 includes one or more anchoring windows 155 for permitting the expandable elements 150 of the  
10 anchoring device 135 to engage the wellbore casing 100 and the expandable tubular member 140.

          In a preferred embodiment, the expandable tubular member 140 further includes a lower section 160, an intermediate section 165, and an upper section 170. In a preferred embodiment, the lower section 160 includes the anchoring  
15 windows 155 in order to provide anchoring at an end portion of the expandable tubular member 140. In a preferred embodiment, the wall thickness of the lower and intermediate sections, 160 and 165, are less than the wall thickness of the upper section 170 in order to optimally couple the radially expanded portion of the expandable tubular member 140 to the wellbore casing 100.

20           In a preferred embodiment, the expandable tubular member 140 is further provided substantially as disclosed in one or more of the following: (1) U.S. utility patent application serial no. 09/454,139, attorney docket no. 25791.3.02, filed on 12/3/1999, which claimed the benefit of the filing date of U.S. provisional patent application no. 60/111,293, attorney docket no. 25791.3, filed on 12/7/1998; (2) U.S.  
25 utility patent application serial no. 09/510,913, attorney docket no. 25791.7.02, filed on 2/23/2000, which claimed the benefit of the filing date of U.S. provisional application no. 60/121,702, filed on 2/25/1999; (3) U.S. utility patent application serial no. 09/502,350, attorney docket no. 25791.8.02, filed on 2/10/2000, which claimed the benefit of the filing date of U.S. provisional application no. 60/119,611, attorney docket no. 25791.8; (4) U.S. utility patent application serial no. 09/440,338, attorney docket no. 25791.9.02, filed on 11/15/1999, which claimed the benefit of the filing date of U.S. provisional application no. 60/108,558, attorney docket no. 25791.9, filed on 11/16.1998; (5) U.S. provisional patent application no. 60/183,546, filed on 2/18/2000; (6) U.S. utility patent application no. 09/523,460, attorney docket  
30 attorney docket no. 25791.9.02, filed on 11/15/1999, which claimed the benefit of the filing date of U.S. provisional application no. 60/108,558, attorney docket no. 25791.9, filed on 11/16.1998; (5) U.S. provisional patent application no. 60/183,546, filed on 2/18/2000; (6) U.S. utility patent application no. 09/523,460, attorney docket  
35 no. 25791.11.02, filed on 3/10/2000, which claimed the benefit of the filing date of



U.S. provisional application no. 60/124,042, filed on 3/11/1999; (7) U.S. utility patent application no. 09/512,895, attorney docket no. 25791.12.02, filed on 2/24/2000, which claimed the benefit of the filing dates of U.S. provisional application no. 60/121,841, attorney docket no. 25791.12, filed on 2/26/1999 and U.S. provisional  
5 application no. 60/154,047, attorney docket no. 25791.29, filed on 9/16/1999; (8) U.S. utility application no. 09/511,941, attorney docket no. 25791.16.02, filed on 2/24/2000, which claimed the benefit of the filing date of U.S. provisional serial no. 60/121,907, attorney docket no. 25791.16, filed on 2/26/1999; (9) U.S. utility patent application no. 09/588,946, attorney docket no. 25791.17.02, filed on June 7, 2000,  
10 which claimed the benefit of the filing date of U.S. provisional patent application serial no. 60/137,998, attorney docket no. 25791.17, filed on 6/7/1999; (10) U.S. utility patent application no. 09/559,122, attorney docket no. 25791.23.02, filed on 4/26/2000, which claimed the benefit of the filing date of U.S. provisional application no. 60/131,106, attorney docket no. 25791.23, filed on 4/26/1999; (11) U.S.  
15 provisional application no. 60/146,203, attorney docket no. 25791.25, filed on 7/29/1999; (12) U.S. provisional application no. 60/143,039, attorney docket no. 25791.26, filed on 7/9/1999; (13) U.S. provisional patent application serial no. 60/162,671, attorney docket no. 25791.27, filed on 11/1/1999; (14) U.S. provisional application no. 60/159,039, attorney docket no. 25791.36, filed on 10/12,1999; (15)  
20 U.S. provisional patent application no. 60/159,033, attorney docket no. 25791.37, filed on 10/12/1999; and (16) U.S. provisional patent application no. 60/165,228, attorney docket no. 25791.39, filed on 11/12/1999, the disclosures of which are incorporated herein by reference.

The sealing members 145 are coupled to the outer surface of the upper  
25 portion 170 of the expandable tubular member 140. The sealing members 145 are preferably adapted to engage and fluidically seal the interface between the radially expanded expandable tubular member 140 and the wellbore casing 100. In a preferred embodiment, the apparatus 115 includes a plurality of sealing members 145. In a preferred embodiment, the sealing members 145 surround and isolate the  
30 opening 110.

As illustrated in FIG. 1a, the apparatus 115 is preferably positioned within the wellbore casing 100 with the expandable tubular member 140 positioned in opposing relation to the opening 110. In a preferred embodiment, the apparatus 115 includes a plurality of sealing members 145 that are positioned above and

below the opening 110. In this manner, the radial expansion of the expandable tubular member 140 optimally fluidically isolates the opening 110.

As illustrated in FIG. 1b, the apparatus 115 is then anchored to the wellbore casing 100 using the anchoring device 135. In a preferred embodiment, the  
5 anchoring device 135 is pressurized and the expandable element 150 is extended from the anchoring device 135 through the corresponding anchoring window 155 in the expandable tubular member 140 into intimate contact with the wellbore casing 100. In this manner, the lower section 160 of the expandable tubular member 140 is removably coupled to the wellbore casing 100.

10 In an alternative embodiment, a compressible cement and/or epoxy is then injected into the annular space between the unexpanded portion of the tubular member 140 and the wellbore casing 100. The compressible cement and/or epoxy is then permitted to at least partially cure prior to the initiation of the radial expansion process. In this manner, an annular structural support and fluidic seal is provided  
15 around the tubular member 140.

As illustrated in FIG. 1c, the expansion cone 130 is then axially displaced by applying an axial force to the second support member 125. In a preferred embodiment, the axial displacement of the expansion cone 130 radially expands the  
20 expandable tubular member 140 into intimate contact with the walls of the wellbore casing 100.

In an alternative embodiment, as illustrated in FIG. 1d, the axial displacement of the expansion cone 130 is enhanced by injecting a pressurized fluidic material into the annular space between the first support member 120 and the  
25 second support member 125. In this manner, an upward axial force is applied to the lower annular face of the expansion cone 130 using the pressurized fluidic material. In this manner, a temporary need for increased axial force during the radial expansion process can be easily satisfied.

As illustrated in FIGS. 1e, 1f, and 1g, after the expandable tubular member 140 has been radially expanded by the axial displacement of the expansion cone  
30 130, the first support member 120 and the anchoring device 135 are preferably removed from expandable tubular member 140 by de-pressurizing the anchoring device 135 and then lifting the first support member 120 and anchoring device 135 from the wellbore casing 100.

As illustrated in FIG. 1g, in a preferred embodiment, the opening 110 in the  
35 wellbore casing 100 is sealed off by the radially expanded tubular member 140. In

this manner, repairs to the wellbore casing 100 are optimally provided. More generally, the apparatus 115 is used to repair or form wellbore casings, pipelines, and structural supports.

5 Referring to FIGS, 2a, 2b, 2c, 2d, 2e and 2f, an alternative embodiment of a method and apparatus for coupling an expandable tubular member to a preexisting structure will be described. Referring to Fig. 2a, a wellbore casing 200 and an open hole wellbore section 205 are positioned within a subterranean formation 210. The wellbore casing 200 and the open hole wellbore section 205 may be positioned in any orientation from the vertical direction to the horizontal direction.

10 In a preferred embodiment, an apparatus 215 is utilized to couple an expandable tubular member to an end portion of the wellbore casing 200. In this manner, the open hole wellbore section 205 is provided with a cased portion. More generally, the apparatus 215 is preferably utilized to form or repair wellbore casings, pipelines, or structural supports.

15 The apparatus 215 preferably includes a first support member 220, a second support member 225, an expansion cone 230, an anchoring device 235, an expandable tubular member 240, one or more upper sealing members 245, one or more lower sealing members 250, and a flexible coupling element 255.

20 The first support member 220 is preferably adapted to be coupled to a surface location. The first support member 220 is further coupled to the anchoring device 235. The first support member 220 is preferably adapted to convey pressurized fluidic materials and/or electrical current and/or communication signals from a surface location to the anchoring device 235. The first support member 220 may, for example, be conventional commercially available slick wire, braided wire, 25 coiled tubing, or drilling stock material.

The second support member 225 is preferably adapted to be coupled to a surface location. The second support member 225 is further coupled to the expansion cone 230. The second support member 225 is preferably adapted to permit the expansion cone 230 to be axially displaced relative to the first support member 220. The second support member 225 may, for example, be conventional 30 commercially available slick wire, braided wire, coiled tubing, or drilling stock material.

In an alternative embodiment, the support member 220 is telescopically coupled to the support member 225, and the support member 225 is coupled to a 35 surface support structure.

The expansion cone 230 is coupled to the second support member 225. The expansion cone 230 is preferably adapted to radially expand the expandable tubular member 240 when the expansion cone 230 is axially displaced relative to the expandable tubular member 240. In a preferred embodiment, the expansion cone

5 230 is provided substantially as disclosed in one or more of the following: (1) U.S. utility patent application serial no. 09/454,139, attorney docket no. 25791.3.02, filed on 12/3/1999, which claimed the benefit of the filing date of U.S. provisional patent application no. 60/111,293, attorney docket no. 25791.3, filed on 12/7/1998; (2) U.S. utility patent application serial no. 09/510,913, attorney docket no. 25791.7.02, filed

10 on 2/23/2000, which claimed the benefit of the filing date of U.S. provisional application no. 60/121,702, filed on 2/25/1999; (3) U.S. utility patent application serial no. 09/502,350, attorney docket no. 25791.8.02, filed on 2/10/2000, which claimed the benefit of the filing date of U.S. provisional application no. 60/119,611, attorney docket no. 25791.8; (4) U.S. utility patent application serial no. 09/440,338,

15 attorney docket no. 25791.9.02, filed on 11/15/1999, which claimed the benefit of the filing date of U.S. provisional application no. 60/108,558, attorney docket no. 25791.9, filed on 11/16.1998; (5) U.S. provisional patent application no. 60/183,546, filed on 2/18/2000; (6) U.S. utility patent application no. 09/523,460, attorney docket no. 25791.11.02, filed on 3/10/2000, which claimed the benefit of the filing date of

20 U.S. provisional application no. 60/124,042, filed on 3/11/1999; (7) U.S. utility patent application no. 09/512,895, attorney docket no. 25791.12.02, filed on 2/24/2000, which claimed the benefit of the filing dates of U.S. provisional application no. 60/121,841, attorney docket no. 25791.12, filed on 2/26/1999 and U.S. provisional application no. 60/154,047, attorney docket no. 25791.29, filed on 9/16/1999; (8)

25 U.S. utility application no. 09/511,941, attorney docket no. 25791.16.02, filed on 2/24/2000, which claimed the benefit of the filing date of U.S. provisional serial no. 60/121,907, attorney docket no. 25791.16, filed on 2/26/1999; (9) U.S. utility patent application no. 09/588,946, attorney docket no. 25791.17.02, filed on June 7, 2000, which claimed the benefit of the filing date of U.S. provisional patent application

30 serial no. 60/137,998, attorney docket no. 25791.17, filed on 6/7/1999; (10) U.S. utility patent application no. 09/559,122, attorney docket no. 25791.23.02, filed on 4/26/2000, which claimed the benefit of the filing date of U.S. provisional application no. 60/131,106, attorney docket no. 25791.23, filed on 4/26/1999; (11) U.S. provisional application no. 60/146,203, attorney docket no. 25791.25, filed on

35 7/29/1999; (12) U.S. provisional application no. 60/143,039, attorney docket no.

25791.26, filed on 7/9/1999; (13) U.S. provisional patent application serial no. 60/162,671, attorney docket no. 25791.27, filed on 11/1/1999; (14) U.S. provisional application no. 60/159,039, attorney docket no. 25791.36, filed on 10/12,1999; (15) U.S. provisional patent application no. 60/159,033, attorney docket no. 25791.37,  
5 filed on 10/12/1999; and (16) U.S. provisional patent application no. 60/165,228, attorney docket no. 25791.39, filed on 11/12/1999, the disclosures of which are incorporated herein by reference.

The anchoring device 235 is coupled to the first support member 220. The anchoring device 235 is preferably adapted to be controllably coupled to the  
10 expandable tubular member 240 and the open hole wellbore section 205. In this manner, the anchoring device 235 preferably controllably anchors the expandable tubular member 240 to the open hole wellbore section 205 to facilitate the radial expansion of the expandable tubular member 240 by the axial displacement of the expansion cone 230. In a preferred embodiment, the anchoring device 235 includes  
15 one or more expandable elements 260 that are adapted to controllably extend from the body of the anchoring device 235 to engage both the flexible coupling element 255 and the open hole wellbore section 205. In a preferred embodiment, the expandable elements 260 are actuated using fluidic pressure. In a preferred embodiment, the anchoring device 235 is any one of the hydraulically actuated  
20 packers commercially available from Halliburton Energy Services or Baker-Hughes.

The expandable tubular member 240 is removably coupled to the expansion cone 230. The expandable tubular member 240 is further preferably coupled to the flexible coupling element 255.

In a preferred embodiment, the expandable tubular member 240 further  
25 includes a lower section 265, an intermediate section 270, and an upper section 275. In a preferred embodiment, the lower section 265 is coupled to the flexible coupling element 255 in order to provide anchoring at an end portion of the expandable tubular member 240. In a preferred embodiment, the wall thickness of the lower and intermediate sections, 265 and 270, are less than the wall thickness of  
30 the upper section 275 in order to optimally couple the radially expanded portion of the expandable tubular member 240 to the wellbore casing 200 and the open hole wellbore section 205.

In a preferred embodiment, the expandable tubular member 240 is further provided substantially as disclosed in one or more of the following: (1) U.S. utility  
35 patent application serial no. 09/454,139, attorney docket no. 25791.3.02, filed on

12/3/1999, which claimed the benefit of the filing date of U.S. provisional patent application no. 60/111,293, attorney docket no. 25791.3, filed on 12/7/1998; (2) U.S. utility patent application serial no. 09/510,913, attorney docket no. 25791.7.02, filed on 2/23/2000, which claimed the benefit of the filing date of U.S. provisional application no. 60/121,702, filed on 2/25/1999; (3) U.S. utility patent application serial no. 09/502,350, attorney docket no. 25791.8.02, filed on 2/10/2000, which claimed the benefit of the filing date of U.S. provisional application no. 60/119,611, attorney docket no. 25791.8; (4) U.S. utility patent application serial no. 09/440,338, attorney docket no. 25791.9.02, filed on 11/15/1999, which claimed the benefit of the filing date of U.S. provisional application no. 60/108,558, attorney docket no. 25791.9, filed on 11/16.1998; (5) U.S. provisional patent application no. 60/183,546, filed on 2/18/2000; (6) U.S. utility patent application no. 09/523,460, attorney docket no. 25791.11.02, filed on 3/10/2000, which claimed the benefit of the filing date of U.S. provisional application no. 60/124,042, filed on 3/11/1999; (7) U.S. utility patent application no. 09/512,895, attorney docket no. 25791.12.02, filed on 2/24/2000, which claimed the benefit of the filing dates of U.S. provisional application no. 60/121,841, attorney docket no. 25791.12, filed on 2/26/1999 and U.S. provisional application no. 60/154,047, attorney docket no. 25791.29, filed on 9/16/1999; (8) U.S. utility application no. 09/511,941, attorney docket no. 25791.16.02, filed on 2/24/2000, which claimed the benefit of the filing date of U.S. provisional serial no. 60/121,907, attorney docket no. 25791.16, filed on 2/26/1999; (9) U.S. utility patent application no. 09/588,946, attorney docket no. 25791.17.02, filed on June 7, 2000, which claimed the benefit of the filing date of U.S. provisional patent application serial no. 60/137,998, attorney docket no. 25791.17, filed on 6/7/1999; (10) U.S. utility patent application no. 09/559,122, attorney docket no. 25791.23.02, filed on 4/26/2000, which claimed the benefit of the filing date of U.S. provisional application no. 60/131,106, attorney docket no. 25791.23, filed on 4/26/1999; (11) U.S. provisional application no. 60/146,203, attorney docket no. 25791.25, filed on 7/29/1999; (12) U.S. provisional application no. 60/143,039, attorney docket no. 25791.26, filed on 7/9/1999; (13) U.S. provisional patent application serial no. 60/162,671, attorney docket no. 25791.27, filed on 11/1/1999; (14) U.S. provisional application no. 60/159,039, attorney docket no. 25791.36, filed on 10/12,1999; (15) U.S. provisional patent application no. 60/159,033, attorney docket no. 25791.37, filed on 10/12/1999; and (16) U.S. provisional patent application no. 60/165,228,

attorney docket no. 25791.39, filed on 11/12/1999, the disclosures of which are incorporated herein by reference.

The upper sealing members 245 are coupled to the outer surface of the upper portion 275 of the expandable tubular member 240. The upper sealing members 245 are preferably adapted to engage and fluidically seal the interface between the radially expanded expandable tubular member 240 and the wellbore casing 200. In a preferred embodiment, the apparatus 215 includes a plurality of upper sealing members 245.

The lower sealing members 250 are coupled to the outer surface of the upper portion 275 of the expandable tubular member 240. The lower sealing members 250 are preferably adapted to engage and fluidically seal the interface between the radially expanded expandable tubular member 240 and the open wellbore section 205. In a preferred embodiment, the apparatus 215 includes a plurality of lower sealing members 250.

The flexible coupling element 255 is coupled to the lower portion 265 of the expandable tubular member 240. The flexible coupling element 255 is preferably adapted to radially expand by the anchoring device 235 into engagement within the walls of the open hole wellbore section 205. In this manner, the lower portion 265 of the expandable tubular member 240 is coupled to the walls of the open hole wellbore section 205. In a preferred embodiment, the flexible coupling element 255 is a slotted tubular member. In a preferred embodiment, the flexible coupling element 255 includes one or more hook elements for engaging the walls of the open hole wellbore section 205.

As illustrated in FIG. 2a, the apparatus 215 is preferably positioned with the expandable tubular member 240 positioned in overlapping relation with a portion of the wellbore casing 200. In this manner, the radially expanded tubular member 240 is coupled to the lower portion of the wellbore casing 200. In a preferred embodiment, the upper sealing members 245 are positioned in opposing relation to the lower portion of the wellbore casing 200 and the lower sealing members 250 are positioned in opposing relation to the walls of the open hole wellbore section 205. In this manner, the interface between the radially expanded tubular member 240 and the wellbore casing 200 and open hole wellbore section 205 is optimally fluidically sealed.

As illustrated in FIG. 2b, the apparatus 215 is then anchored to the open hole wellbore section 205 using the anchoring device 235. In a preferred

embodiment, the anchoring device 235 is pressurized and the expandable element 260 is radially extended from the anchoring device 235 causing the flexible coupling element 255 to radially expand into intimate contact with the walls of the open hole wellbore section 205. In this manner, the lower section 265 of the expandable tubular member 240 is removably coupled to the walls of the open hole wellbore section 205.

In an alternative embodiment, a compressible cement and/or epoxy is then injected into the annular space between the unexpanded portion of the tubular member 240 and the wellbore casing 100 and/or the open hole wellbore section 205. The compressible cement and/or epoxy is then permitted to at least partially cure prior to the initiation of the radial expansion process. In this manner, an annular structural support and fluidic seal is provided around the tubular member 240.

As illustrated in FIG. 2c, the expansion cone 230 is then axially displaced by applying an axial force to the second support member 225. In a preferred embodiment, the axial displacement of the expansion cone 230 radially expands the expandable tubular member 240 into intimate contact with the walls of the open hole wellbore section 205.

In an alternative embodiment, as illustrated in FIG. 2d, the axial displacement of the expansion cone 230 is enhanced by injecting a pressurized fluidic material into the annular space between the first support member 220 and the second support member 225. In this manner, an upward axial force is applied to the lower annular face of the expansion cone 230 using the pressurized fluidic material. In this manner, a temporary need for increased axial force during the radial expansion process can be easily satisfied.

As illustrated in FIGS. 2e and 2f, after the expandable tubular member 240 has been radially expanded by the axial displacement of the expansion cone 230, the first support member 220 and the anchoring device 235 are preferably removed from expandable tubular member 240 by de-pressurizing the anchoring device 235 and then lifting the first support member 220 and anchoring device 235 from the wellbore casing 200 and the open hole wellbore section 205.

Referring to FIGS, 3a, 3b, 3c, and 3d, an alternative embodiment of a method and apparatus for coupling an expandable tubular member to a preexisting structure will be described. Referring to Fig. 3a, a wellbore casing 300 is positioned within a subterranean formation 305. The wellbore casing 300 may be positioned in



any orientation from the vertical direction to the horizontal direction. The wellbore casing 300 further includes one or more openings 310 that may have been the result of unintentional damage to the wellbore casing 300, or due to a prior perforation or fracturing operation performed upon the surrounding subterranean formation 305.

5 As will be recognized by persons having ordinary skill in the art, the openings 310 can adversely affect the subsequent operation and use of the wellbore casing 300 unless they are sealed off.

In a preferred embodiment, an apparatus 315 is utilized to seal off the openings 310 in the wellbore casing 300. More generally, the apparatus 315 is preferably utilized to form or repair wellbore casings, pipelines, or structural supports.

The apparatus 315 preferably includes a support member 320, an expansion cone 325, an anchoring device 330, an expandable tubular member 335, and one or more sealing members 340.

15 The support member 320 is preferably adapted to be coupled to a surface location. The support member 320 is further coupled to the expansion cone 325 and the anchoring device 330. The support member 320 is preferably adapted to convey pressurized fluidic materials and/or electrical current and/or communication signals from a surface location to the anchoring device 330. The support member  
20 320 may, for example, be conventional commercially available slick wire, braided wire, coiled tubing, or drilling stock material.

The expansion cone 325 is coupled to the support member 320. The expansion cone 325 is preferably adapted to radially expand the expandable tubular member 335 when the expansion cone 325 is axially displaced relative to the expandable tubular member 335. In a preferred embodiment, the expansion cone  
25 325 is provided substantially as disclosed in one or more of the following: (1) U.S. utility patent application serial no. 09/454,139, attorney docket no. 25791.3.02, filed on 12/3/1999, which claimed the benefit of the filing date of U.S. provisional patent application no. 60/111,293, attorney docket no. 25791.3, filed on 12/7/1998; (2) U.S.  
30 utility patent application serial no. 09/510,913, attorney docket no. 25791.7.02, filed on 2/23/2000, which claimed the benefit of the filing date of U.S. provisional application no. 60/121,702, filed on 2/25/1999; (3) U.S. utility patent application serial no. 09/502,350, attorney docket no. 25791.8.02, filed on 2/10/2000, which claimed the benefit of the filing date of U.S. provisional application no. 60/119,611,  
35 attorney docket no. 25791.8; (4) U.S. utility patent application serial no. 09/440,338,

attorney docket no. 25791.9.02, filed on 11/15/1999, which claimed the benefit of the filing date of U.S. provisional application no. 60/108,558, attorney docket no. 25791.9, filed on 11/16.1998; (5) U.S. provisional patent application no. 60/183,546, filed on 2/18/2000; (6) U.S. utility patent application no. 09/523,460, attorney docket no. 25791.11.02, filed on 3/10/2000, which claimed the benefit of the filing date of U.S. provisional application no. 60/124,042, filed on 3/11/1999; (7) U.S. utility patent application no. 09/512,895, attorney docket no. 25791.12.02, filed on 2/24/2000, which claimed the benefit of the filing dates of U.S. provisional application no. 60/121,841, attorney docket no. 25791.12, filed on 2/26/1999 and U.S. provisional application no. 60/154,047, attorney docket no. 25791.29, filed on 9/16/1999; (8) U.S. utility application no. 09/511,941, attorney docket no. 25791.16.02, filed on 2/24/2000, which claimed the benefit of the filing date of U.S. provisional serial no. 60/121,907, attorney docket no. 25791.16, filed on 2/26/1999; (9) U.S. utility patent application no. 09/588,946, attorney docket no. 25791.17.02, filed on June 7, 2000, which claimed the benefit of the filing date of U.S. provisional patent application serial no. 60/137,998, attorney docket no. 25791.17, filed on 6/7/1999; (10) U.S. utility patent application no. 09/559,122, attorney docket no. 25791.23.02, filed on 4/26/2000, which claimed the benefit of the filing date of U.S. provisional application no. 60/131,106, attorney docket no. 25791.23, filed on 4/26/1999; (11) U.S. provisional application no. 60/146,203, attorney docket no. 25791.25, filed on 7/29/1999; (12) U.S. provisional application no. 60/143,039, attorney docket no. 25791.26, filed on 7/9/1999; (13) U.S. provisional patent application serial no. 60/162,671, attorney docket no. 25791.27, filed on 11/1/1999; (14) U.S. provisional application no. 60/159,039, attorney docket no. 25791.36, filed on 10/12,1999; (15) U.S. provisional patent application no. 60/159,033, attorney docket no. 25791.37, filed on 10/12/1999; and (16) U.S. provisional patent application no. 60/165,228, attorney docket no. 25791.39, filed on 11/12/1999, the disclosures of which are incorporated herein by reference.

The anchoring device 330 is coupled to the support member 320 and the expansion cone 325. The anchoring device 335 is preferably adapted to controllably coupled to the expandable tubular member 335 to the wellbore casing 300. In this manner, the anchoring device 330 preferably controllably anchors the expandable tubular member 335 to the wellbore casing 300 to facilitate the radial expansion of the expandable tubular member 335 by the axial displacement of the expansion cone 325. In a preferred embodiment, the anchoring device 330 includes one or

more expandable elements 345 that are adapted to controllably extend from the body of the anchoring device 330 to radially displace corresponding engagement elements 350 provided in the expandable tubular member 335. In a preferred embodiment, the radial displacement of the engagement elements 350 couples the  
5 expandable tubular member 335 to the wellbore casing 300. In a preferred embodiment, the expandable elements 345 are pistons that are actuated using fluidic pressure. In a preferred embodiment, the anchoring device 330 is any one of the hydraulically actuated anchoring devices commercially available from Halliburton Energy Services or Baker-Hughes.

10 In an alternative embodiment, the expandable elements 345 are explosive devices that controllably generate a radially directed explosive force for radially displacing the engagement elements 350. In a preferred embodiment, the explosive expandable elements 345 are shaped explosive charges commercially available from Halliburton Energy Services.

15 The expandable tubular member 335 is removably coupled to the expansion cone 325. In a preferred embodiment, the expandable tubular member 335 includes one or more engagement devices 350 that are adapted to be radially displaced by the anchoring device 330 into engagement with the walls of the wellbore casing 300. In this manner, the expandable tubular member 335 is coupled to the wellbore  
20 casing 300. In a preferred embodiment, the engagement devices 350 include teeth for biting into the surface of the wellbore casing 100.

In a preferred embodiment, the expandable tubular member 335 further includes a lower section 355, an intermediate section 360, and an upper section 365. In a preferred embodiment, the lower section 355 includes the engagement  
25 device 350 in order to provide anchoring at an end portion of the expandable tubular member 335. In a preferred embodiment, the wall thickness of the lower and intermediate sections, 355 and 360, are less than the wall thickness of the upper section 365 in order to optimally couple the radially expanded portion of the expandable tubular member 335 to the wellbore casing 300.

30 In a preferred embodiment, the expandable tubular member 335 is further provided substantially as disclosed in one or more of the following: (1) U.S. utility patent application serial no. 09/454,139, attorney docket no. 25791.3.02, filed on 12/3/1999, which claimed the benefit of the filing date of U.S. provisional patent application no. 60/111,293, attorney docket no. 25791.3, filed on 12/7/1998; (2) U.S.  
35 utility patent application serial no. 09/510,913, attorney docket no. 25791.7.02, filed

on 2/23/2000, which claimed the benefit of the filing date of U.S. provisional application no. 60/121,702, filed on 2/25/1999; (3) U.S. utility patent application serial no. 09/502,350, attorney docket no. 25791.8.02, filed on 2/10/2000, which claimed the benefit of the filing date of U.S. provisional application no. 60/119,611, attorney docket no. 25791.8; (4) U.S. utility patent application serial no. 09/440,338, attorney docket no. 25791.9.02, filed on 11/15/1999, which claimed the benefit of the filing date of U.S. provisional application no. 60/108,558, attorney docket no. 25791.9, filed on 11/16.1998; (5) U.S. provisional patent application no. 60/183,546, filed on 2/18/2000; (6) U.S. utility patent application no. 09/523,460, attorney docket no. 25791.11.02, filed on 3/10/2000, which claimed the benefit of the filing date of U.S. provisional application no. 60/124,042, filed on 3/11/1999; (7) U.S. utility patent application no. 09/512,895, attorney docket no. 25791.12.02, filed on 2/24/2000, which claimed the benefit of the filing dates of U.S. provisional application no. 60/121,841, attorney docket no. 25791.12, filed on 2/26/1999 and U.S. provisional application no. 60/154,047, attorney docket no. 25791.29, filed on 9/16/1999; (8) U.S. utility application no. 09/511,941, attorney docket no. 25791.16.02, filed on 2/24/2000, which claimed the benefit of the filing date of U.S. provisional serial no. 60/121,907, attorney docket no. 25791.16, filed on 2/26/1999; (9) U.S. utility patent application no. 09/588,946, attorney docket no. 25791.17.02, filed on June 7, 2000, which claimed the benefit of the filing date of U.S. provisional patent application serial no. 60/137,998, attorney docket no. 25791.17, filed on 6/7/1999; (10) U.S. utility patent application no. 09/559,122, attorney docket no. 25791.23.02, filed on 4/26/2000, which claimed the benefit of the filing date of U.S. provisional application no. 60/131,106, attorney docket no. 25791.23, filed on 4/26/1999; (11) U.S. provisional application no. 60/146,203, attorney docket no. 25791.25, filed on 7/29/1999; (12) U.S. provisional application no. 60/143,039, attorney docket no. 25791.26, filed on 7/9/1999; (13) U.S. provisional patent application serial no. 60/162,671, attorney docket no. 25791.27, filed on 11/1/1999; (14) U.S. provisional application no. 60/159,039, attorney docket no. 25791.36, filed on 10/12,1999; (15) U.S. provisional patent application no. 60/159,033, attorney docket no. 25791.37, filed on 10/12/1999; and (16) U.S. provisional patent application no. 60/165,228, attorney docket no. 25791.39, filed on 11/12/1999, the disclosures of which are incorporated herein by reference.

The sealing members 340 are coupled to the outer surface of the upper portion 365 of the expandable tubular member 335. The sealing members 340 are

preferably adapted to engage and fluidically seal the interface between the radially expanded expandable tubular member 335 and the wellbore casing 300. In a preferred embodiment, the apparatus 315 includes a plurality of sealing members 340. In a preferred embodiment, the sealing members 340 surround and isolate the opening 310.

As illustrated in FIG. 3a, the apparatus 315 is preferably positioned within the wellbore casing 300 with the expandable tubular member 335 positioned in opposing relation to the opening 310. In a preferred embodiment, the apparatus 315 includes a plurality of sealing members 340 that are positioned above and below the opening 310. In this manner, the radial expansion of the expandable tubular member 335 optimally fluidically isolates the opening 310.

As illustrated in FIG. 3b, the expandable tubular member 335 of the apparatus 315 is then anchored to the wellbore casing 300 using the anchoring device 330. In a preferred embodiment, the anchoring device 330 is pressurized and the expandable element 345 is extended from the anchoring device 330 and radially displaces the corresponding engagement elements 350 of the expandable tubular member 335 into intimate contact with the wellbore casing 300. In this manner, the lower section 355 of the expandable tubular member 335 is coupled to the wellbore casing 300.

In an alternative embodiment, a compressible cement and/or epoxy is then injected into the annular space between the unexpanded portion of the tubular member 335 and the wellbore casing 300. The compressible cement and/or epoxy is then permitted to at least partially cure prior to the initiation of the radial expansion process. In this manner, an annular structural support and fluidic seal is provided around the tubular member 335.

As illustrated in FIG. 3c, the anchoring device 330 is then deactivated and the expansion cone 325 is axially displaced by applying an axial force to the support member 320. In a preferred embodiment, the deactivation of the anchoring device 330 causes the expandable elements 345 to radially retract into the anchoring device 330. Alternatively, the expandable elements 345 are resiliently coupled to the anchoring device 330. In this manner, the expandable elements 345 retract automatically upon the deactivation of the anchoring device 330. In a preferred embodiment, the axial displacement of the expansion cone 325 radially expands the expandable tubular member 335 into intimate contact with the walls of the wellbore casing 300.

As illustrated in FIG. 3d, after the expandable tubular member 335 has been radially expanded by the axial displacement of the expansion cone 335, the support member 320, expansion cone 325, and the anchoring device 330 are preferably removed from the expanded expandable tubular member 335.

5 In a preferred embodiment, the opening 310 in the wellbore casing 300 is sealed off by the radially expanded tubular member 335. In this manner, repairs to the wellbore casing 300 are optimally provided. More generally, the apparatus 315 is used to repair or form wellbore casings, pipelines, and structural supports.

Referring to FIG. 4, an embodiment of a system 400 for applying an axial  
10 force to the expansion cones 130, 230, and 325 includes a lifting device 405, a first support member 410, a shock absorber 415, and a second support member 420. In a preferred embodiment, the system 400 is adapted to minimize the transfer of shock loads, created during the completion of the radial expansion of tubular members by the expansion cones 130, 230, and 325, to the lifting device 405. In  
15 this manner, the radial expansion of tubular members by the expansion cones 130, 230 and 325 is provided in an optimally safe manner.

The lifting device 405 is supported at a surface location and is coupled to the first support member 410. The lifting device 405 may comprise any number of conventional commercially available lifting devices suitable for manipulating tubular  
20 members within a wellbore.

The first support member 410 is coupled to the lifting device 405 and the shock absorber 415. The first support member 410 may comprise any number of conventional commercially available support members such as, for example, coiled tubing, a drill string, a wireline, braided wire, or a slick line.

25 The shock absorber 415 is coupled to the first support member 410 and the second support member 420. The shock absorber 415 is preferably adapted to absorb shock loads transmitted from the second support member 420. The shock absorber 415 may be any number of conventional commercially available shock absorbers.

30 The second support member 420 is coupled to the shock absorber 415. The second support member 420 is further preferably adapted to be coupled to one or more of the expansion cones 130, 230 and 325.

In a preferred embodiment, during operation of the system 400, the lifting device applies an axial force to one of the expansion cones 130, 230 and 325 in  
35 order to radially expand tubular members. In a preferred embodiment, upon the

completion of the radial expansion process, when the expansion cones 130, 230 and 325, exit the radially expanded tubular members, the sudden shock loads generated are absorbed, or at least minimized, by the shock absorber 415. In this manner, the radial expansion of tubular members by pulling the expansion cones  
5 130, 230 and 325 using the lifting device 405 is provided in an optimally safe manner.

Referring to FIG. 5, an embodiment of a coupling system 500 for use in the expandable tubular members 140, 240, and 335 will now be described. In a preferred embodiment, the system 500 includes an upper ring 505, a sealing element 510, and a lower ring 515. In a preferred embodiment, the upper ring 505,  
10 the sealing element 510, and the lower ring 515 are provided on the outer surfaces of the expandable tubular members 140, 240, and 335. In this manner, when the expandable tubular members 140, 240 and 335 are radially expanded, the upper ring 505, the sealing element 510, and the lower ring 515 engage the interior  
15 surface of the preexisting structure that the expandable tubular members 140, 240 and 335 are coupled to. In a preferred embodiment, the upper and lower rings, 505 and 515, penetrate the interior surface of the preexisting structure that the expandable tubular members 140, 240 and 335 are coupled to in order to optimally anchor the tubular members 140, 240 and 335 to the preexisting structure. In a  
20 preferred embodiment, the sealing element 510 is compressed into contact with the interior surface of the preexisting structure that the expandable tubular members 140, 240 and 335 are coupled to in order to optimally fluidically seal the interface between the tubular members 140, 240 and 335 and the preexisting structure.

In a preferred embodiment, the upper and lower rings, 505 and 515, extend  
25 from the outer surfaces of the tubular members 140, 240 and 335 by a distance of about 1/64 to 1/2 inches. In a preferred embodiment, the upper and lower rings, 505 and 515, extend about 1/8" from the outer surfaces of the tubular members 140, 240, and 335 in order to optimally engage the preexisting structure.

In a preferred embodiment, the sealing element 510 extends from the outer  
30 surfaces of the tubular members 140, 240 and 335 by a distance substantially equal to the extension of the upper and lower rings, 505 and 515, above the outer surfaces of the tubular members 140, 240 and 335. In a preferred embodiment, the sealing element 510 is fabricated from rubber in order to optimally fluidically seal and engage the preexisting structure.

In a preferred embodiment, the tubular members 140, 240 and 335 include a plurality of the coupling systems 500. In a preferred embodiment, the coupling systems 500 are provided on the lower, intermediate, and upper portions of the tubular members 140, 240, and 335.

5 Referring now to FIG. 6, a preferred embodiment of an expandable tubular member 600 for use in the apparatus 115, 215 and 315 will be described. The tubular member 600 preferably includes a lower portion 605, an intermediate portion 610, and an upper portion 615.

10 The lower portion 605 is coupled to the intermediate portion 610. In a preferred embodiment, the lower portion 605 is further adapted to mate with the anchoring devices 135, 235, and 330. In a preferred embodiment, the lower portion 605 further preferably includes one or more slotted portions 620 for facilitating the radial expansion of the lower portion 605 by the anchoring devices 135, 235, and 330. In this manner, the lower portion 605 of the tubular member 600 is preferably  
15 radially expanded by the anchoring devices 135, 235, and 330 into contact with the preexisting structure. Furthermore, in this manner, the lower portion 605 of the tubular member 600 is anchored to the preexisting structure prior to the initiation of the radial expansion process.

20 The intermediate portion 610 is coupled to the lower portion 605 and the upper portion 615. In a preferred embodiment, the wall thicknesses of the lower and intermediate portions, 605 and 610, are less than the wall thickness of the upper portion 615 in order to facilitate the radial expansion of the tubular member 600. In a preferred embodiment, the lower and intermediate portions, 605 and 610, are preexpanded to mate with the expansion cone.

25 Referring to FIG. 7, a preferred embodiment of an expandable tubular member 700 for use in the apparatus 115, 215 and 315 will be described. In a preferred embodiment, the tubular member 700 minimizes the shock loads created upon the completion of the radial expansion process. In a preferred embodiment, the tubular member 700 includes a lower portion 705, a lower transitional portion  
30 710, an intermediate portion 715, an upper transitional portion 720, an upper portion 725, and a sealing element 730.

The lower portion 705 is coupled to the lower transitional portion 710. The lower portion 705 is preferably adapted to mate with the expansion cone and the anchoring device.



The lower transitional portion 710 is coupled to the lower portion 705 and the intermediate portion 715. In a preferred embodiment, the lower transitional portion 710 is adapted to mate with the expansion cone. In a preferred embodiment, the wall thicknesses of the lower portion 705 and the lower transitional portion 710 are less than the wall thicknesses of the intermediate portion 715, the upper transitional portion 720 and the upper portion 725 in order to optimally facilitate the radial expansion process.

The intermediate portion 715 is coupled to the lower transitional portion 710 and the upper transitional portion 720. In a preferred embodiment, the outside diameter of the intermediate portion 715 is less than the wall thicknesses of the lower portion 705 and the upper portion 725.

The upper transitional portion 720 is coupled to the intermediate portion 715 and the upper portion 725.

The upper portion 725 is coupled to the upper transitional portion 720.

The sealing element 730 is coupled to the outside surface of the intermediate portion 715. In a preferred embodiment, the outside diameter of the sealing element 730 is less than or equal to the outside diameter of the lower portion 705 and the upper portion 725 in order to optimally protect the sealing element 703 during placement of the tubular member 700 within the preexisting structure.

In a preferred embodiment, during the radial expansion of the tubular member 700 using the apparatus 115, 215 and 315, the preexpansion of the upper transitional portion 720 and the upper portion 725 reduces the shock loads typically created during the end portion of the radial expansion process. In this manner, the radial expansion process is optimally provided in a safe manner. Furthermore, because the sealing element 730 is preferably recessed below the surfaces of the lower portion 705 and the upper portion 725, the sealing element 730 is optimally protected from damage during the placement of the tubular member 700 within the preexisting structure.

Referring to FIG. 8, a preferred embodiment of an expandable tubular member 800 for use in the apparatus 115, 215 and 315 will be described. The tubular member 800 preferably includes a lower portion 805, an intermediate portion 810, and an upper portion 815.

The lower portion 805 is coupled to the intermediate portion 810. In a preferred embodiment, the lower portion 805 is further adapted to mate with the expansion cones 130, 230, 325 and the anchoring devices 135, 235, and 330.

The intermediate portion 810 is coupled to the lower portion 805 and the upper portion 815. In a preferred embodiment, the wall thicknesses of the lower and intermediate portions, 805 and 810, are less than the wall thickness of the upper portion 815 in order to facilitate the radial expansion of the tubular member 800. In a preferred embodiment, the lower and intermediate portions, 805 and 810, are preexpanded to mate with the expansion cone.

The upper portion 815 is coupled to the intermediate portion 810. In a preferred embodiment, the upper portion 815 further preferably includes one or more slotted portions 820 for facilitating the radial expansion of the upper portion 815 by the expansion cones 130, 230, and 325. In this manner, the upper portion 815 of the tubular member 800 is preferably radially expanded by the expansion cones 130, 230, and 325 with minimal shock loads when the expansion cones 130, 230 and 325 exit the expandable tubular member 800.

Referring to FIG. 9, a preferred embodiment of a method of applying an axial force to the expansion cones 130, 230, and 325 will now be described. In a preferred embodiment, the axial displacement of the expansion cones 130, 230, and 325 during the radial expansion process is provided by applying an axial force to the expansion cones 130, 230, and 325. In a preferred embodiment, the axial force provided includes the application of a substantially constant axial force for some time periods and the application of increased axial force for other time periods in order to optimally facilitate the radial expansion process by minimizing the effects of friction. In a preferred embodiment, the application of the increased axial force is provided on a periodic basis in order to optimally provide a variable contact area between the expansion cone and the tubular member being expanded. In an alternative embodiment, the application of the increased axial force is provided on a random basis in order to optimally provide a variable contact area between the expansion cone and the tubular member being expanded. In a preferred embodiment, the duty cycle of the application of constant and increased axial forces ranges from about 90/10 % to 60/40 % in order to optimally radially expand the tubular members. In a preferred embodiment, the ratio of the increased axial force to the substantially constant axial force ranges from about 1.5 to 1 to about 4 to 1 in order to optimally provide a variable contact area between the expansion cone and the tubular member being expanded, promote more even wear of the expansion cone, and clean debris from the expansion cone surface.

Referring to FIGS. 10a to 10i, an embodiment of an apparatus and method for forming a wellbore casing will now be described. As illustrated in FIG. 10a, a wellbore casing 1000 and an open hole wellbore section 1005 are provided in a subterranean formation 1010. The wellbore casing 1000 and open hole wellbore section 1005 may be orientated at any orientation ranging from the vertical to the horizontal. In a preferred embodiment, a new section of wellbore casing is formed in the open hole wellbore section 1005 using an apparatus 1015. More generally, the apparatus 1015 is utilized to form or repair wellbore casings, pipelines, or structural supports.

10 The apparatus 1015 preferably includes a first support member 1020, a second support member 1025, an expansion cone 1030, an anchoring device 1035, an expandable tubular member 1040, one or more upper sealing members 1045, one or more lower sealing members 1050, and a flexible coupling element 1055.

15 The first support member 1020 is preferably adapted to be coupled to a surface location. The first support member 1020 is further coupled to the anchoring device 1035. The first support member 1020 is preferably adapted to convey pressurized fluidic materials and/or electrical current and/or communication signals from a surface location to the anchoring device 1035. The first support member 1020 may, for example, be conventional commercially available slick wire, braided wire, coiled tubing, or drilling stock material.

20 The second support member 1025 is preferably adapted to be coupled to a surface location. The second support member 1025 is further coupled to the expansion cone 1030. The second support member 1025 is preferably adapted to permit the expansion cone 1030 to be axially displaced relative to the first support member 1020. The second support member 1025 may, for example, be conventional commercially available slick wire, braided wire, coiled tubing, or drilling stock material.

30 In an alternative embodiment, the support member 1020 is telescopically coupled to the support member 1025, and the support member 1025 is coupled to a surface support member.

35 The expansion cone 1030 is coupled to the second support member 1025. The expansion cone 1030 is preferably adapted to radially expand the expandable tubular member 1040 when the expansion cone 1030 is axially displaced relative to the expandable tubular member 1040. In a preferred embodiment, the expansion cone 1030 is provided substantially as disclosed in one or more of the following: (1)

U.S. utility patent application serial no. 09/454,139, attorney docket no. 25791.3.02, filed on 12/3/1999, which claimed the benefit of the filing date of U.S. provisional patent application no. 60/111,293, attorney docket no. 25791.3, filed on 12/7/1998; (2) U.S. utility patent application serial no. 09/510,913, attorney docket no. 25791.7.02, filed on 2/23/2000, which claimed the benefit of the filing date of U.S. provisional application no. 60/121,702, filed on 2/25/1999; (3) U.S. utility patent application serial no. 09/502,350, attorney docket no. 25791.8.02, filed on 2/10/2000, which claimed the benefit of the filing date of U.S. provisional application no. 60/119,611, attorney docket no. 25791.8; (4) U.S. utility patent application serial no. 09/440,338, attorney docket no. 25791.9.02, filed on 11/15/1999, which claimed the benefit of the filing date of U.S. provisional application no. 60/108,558, attorney docket no. 25791.9, filed on 11/16.1998; (5) U.S. provisional patent application no. 60/183,546, filed on 2/18/2000; (6) U.S. utility patent application no. 09/523,460, attorney docket no. 25791.11.02, filed on 3/10/2000, which claimed the benefit of the filing date of U.S. provisional application no. 60/124,042, filed on 3/11/1999; (7) U.S. utility patent application no. 09/512,895, attorney docket no. 25791.12.02, filed on 2/24/2000, which claimed the benefit of the filing dates of U.S. provisional application no. 60/121,841, attorney docket no. 25791.12, filed on 2/26/1999 and U.S. provisional application no. 60/154,047, attorney docket no. 25791.29, filed on 9/16/1999; (8) U.S. utility application no. 09/511,941, attorney docket no. 25791.16.02, filed on 2/24/2000, which claimed the benefit of the filing date of U.S. provisional serial no. 60/121,907, attorney docket no. 25791.16, filed on 2/26/1999; (9) U.S. utility patent application no. 09/588,946, attorney docket no. 25791.17.02, filed on June 7, 2000, which claimed the benefit of the filing date of U.S. provisional patent application serial no. 60/137,998, attorney docket no. 25791.17, filed on 6/7/1999; (10) U.S. utility patent application no. 09/559,122, attorney docket no. 25791.23.02, filed on 4/26/2000, which claimed the benefit of the filing date of U.S. provisional application no. 60/131,106, attorney docket no. 25791.23, filed on 4/26/1999; (11) U.S. provisional application no. 60/146,203, attorney docket no. 25791.25, filed on 7/29/1999; (12) U.S. provisional application no. 60/143,039, attorney docket no. 25791.26, filed on 7/9/1999; (13) U.S. provisional patent application serial no. 60/162,671, attorney docket no. 25791.27, filed on 11/1/1999; (14) U.S. provisional application no. 60/159,039, attorney docket no. 25791.36, filed on 10/12,1999; (15) U.S. provisional patent application no. 60/159,033, attorney docket no. 25791.37, filed on 10/12/1999; and (16) U.S. provisional patent

application no. 60/165,228, attorney docket no. 25791.39, filed on 11/12/1999, the disclosures of which are incorporated herein by reference.

The anchoring device 1035 is coupled to the first support member 1020. The anchoring device 1035 is preferably adapted to be controllably coupled to the expandable tubular member 1040 and the open hole wellbore section 1005. In this manner, the anchoring device 1035 preferably controllably anchors the expandable tubular member 1040 to the open hole wellbore section 1005 to facilitate the radial expansion of the expandable tubular member 1040 by the axial displacement of the expansion cone 1030.

In a preferred embodiment, the anchoring device 1035 includes one or more expandable elements 1060 that are adapted to controllably extend from the body of the anchoring device 1035 to engage both the flexible coupling element 1055 and the open hole wellbore section 1005. In a preferred embodiment, the expandable elements 1060 are actuated using fluidic pressure.

In a preferred embodiment, the anchoring device 1035 further includes a fluid passage 1036 adapted to receive a ball plug or other similar valving element. In this manner, fluidic materials can be exhausted from the anchoring device 1035 and the fluid passage 1036 can be controllably plugged. In a preferred embodiment, the anchoring device 1035 is any one of the hydraulically actuated packers commercially available from Halliburton Energy Services or Baker-Hughes, modified in accordance with the teachings of the present disclosure.

In a preferred embodiment, the anchoring devices 135, 235, and 330 are also modified to include a fluid passage that can be controllably plugged in order to permit fluidic materials to be exhausted from the anchoring devices 135, 235, and 330.

The expandable tubular member 1040 is removably coupled to the expansion cone 1030. The expandable tubular member 1040 is further preferably coupled to the flexible coupling element 1055.

In a preferred embodiment, the expandable tubular member 1040 further includes a lower section 1065, an intermediate section 1070, and an upper section 1075. In a preferred embodiment, the lower section 1065 is coupled to the flexible coupling element 1055 in order to provide anchoring at an end portion of the expandable tubular member 1040. In a preferred embodiment, the wall thickness of the lower and intermediate sections, 1065 and 1070, are less than the wall thickness of the upper section 1075 in order to optimally couple the radially expanded portion

of the expandable tubular member 1040 to the wellbore casing 1000 and the open hole wellbore section 1005.

In a preferred embodiment, the expandable tubular member 1040 is further provided substantially as disclosed in one or more of the following: (1) U.S. utility patent application serial no. 09/454,139, attorney docket no. 25791.3.02, filed on 12/3/1999, which claimed the benefit of the filing date of U.S. provisional patent application no. 60/111,293, attorney docket no. 25791.3, filed on 12/7/1998; (2) U.S. utility patent application serial no. 09/510,913, attorney docket no. 25791.7.02, filed on 2/23/2000, which claimed the benefit of the filing date of U.S. provisional application no. 60/121,702, filed on 2/25/1999; (3) U.S. utility patent application serial no. 09/502,350, attorney docket no. 25791.8.02, filed on 2/10/2000, which claimed the benefit of the filing date of U.S. provisional application no. 60/119,611, attorney docket no. 25791.8; (4) U.S. utility patent application serial no. 09/440,338, attorney docket no. 25791.9.02, filed on 11/15/1999, which claimed the benefit of the filing date of U.S. provisional application no. 60/108,558, attorney docket no. 25791.9, filed on 11/16.1998; (5) U.S. provisional patent application no. 60/183,546, filed on 2/18/2000; (6) U.S. utility patent application no. 09/523,460, attorney docket no. 25791.11.02, filed on 3/10/2000, which claimed the benefit of the filing date of U.S. provisional application no. 60/124,042, filed on 3/11/1999; (7) U.S. utility patent application no. 09/512,895, attorney docket no. 25791.12.02, filed on 2/24/2000, which claimed the benefit of the filing dates of U.S. provisional application no. 60/121,841, attorney docket no. 25791.12, filed on 2/26/1999 and U.S. provisional application no. 60/154,047, attorney docket no. 25791.29, filed on 9/16/1999; (8) U.S. utility application no. 09/511,941, attorney docket no. 25791.16.02, filed on 2/24/2000, which claimed the benefit of the filing date of U.S. provisional serial no. 60/121,907, attorney docket no. 25791.16, filed on 2/26/1999; (9) U.S. utility patent application no. 09/588,946, attorney docket no. 25791.17.02, filed on June 7, 2000, which claimed the benefit of the filing date of U.S. provisional patent application serial no. 60/137,998, attorney docket no. 25791.17, filed on 6/7/1999; (10) U.S. utility patent application no. 09/559,122, attorney docket no. 25791.23.02, filed on 4/26/2000, which claimed the benefit of the filing date of U.S. provisional application no. 60/131,106, attorney docket no. 25791.23, filed on 4/26/1999; (11) U.S. provisional application no. 60/146,203, attorney docket no. 25791.25, filed on 7/29/1999; (12) U.S. provisional application no. 60/143,039, attorney docket no. 25791.26, filed on 7/9/1999; (13) U.S. provisional patent application serial no.

60/162,671, attorney docket no. 25791.27, filed on 11/1/1999; (14) U.S. provisional application no. 60/159,039, attorney docket no. 25791.36, filed on 10/12,1999; (15) U.S. provisional patent application no. 60/159,033, attorney docket no. 25791.37, filed on 10/12/1999; and (16) U.S. provisional patent application no. 60/165,228, attorney docket no. 25791.39, filed on 11/12/1999, the disclosures of which are incorporated herein by reference.

In a preferred embodiment, the expandable tubular member 1040 is further provided in accordance with the teachings of embodiments of expandable tubular members described above and illustrated in FIGS. 5-8.

The upper sealing members 1045 are coupled to the outer surface of the upper portion 1075 of the expandable tubular member 1040. The upper sealing members 1045 are preferably adapted to engage and fluidically seal the interface between the radially expanded expandable tubular member 1040 and the wellbore casing 1000. In a preferred embodiment, the apparatus 1015 includes a plurality of upper sealing members 1045.

The lower sealing members 1050 are coupled to the outer surface of the upper portion 1075 of the expandable tubular member 1040. The lower sealing members 1050 are preferably adapted to engage and fluidically seal the interface between the radially expanded expandable tubular member 1040 and the open wellbore section 1005. In a preferred embodiment, the apparatus 1015 includes a plurality of lower sealing members 1050.

The flexible coupling element 1055 is coupled to the lower portion 1065 of the expandable tubular member 1040. The flexible coupling element 1055 is preferably adapted to radially expand by the anchoring device 1035 into engagement within the walls of the open hole wellbore section 1005. In this manner, the lower portion 1065 of the expandable tubular member 1040 is coupled to the walls of the open hole wellbore section 1005. In a preferred embodiment, the flexible coupling element 1055 is a slotted tubular member. In a preferred embodiment, the flexible coupling element 1055 includes one or more hook elements for engaging the walls of the open hole wellbore section 1005.

As illustrated in FIG. 10a, the apparatus 1015 is preferably positioned with the expandable tubular member 1040 positioned in overlapping relation with a portion of the wellbore casing 1000. In this manner, the radially expanded tubular member 1040 is coupled to the lower portion of the wellbore casing 1000. In a preferred embodiment, the upper sealing members 1045 are positioned in opposing

relation to the lower portion of the wellbore casing 1000 and the lower sealing members 1050 are positioned in opposing relation to the walls of the open hole wellbore section 1005. In this manner, the interface between the radially expanded tubular member 1040 and the wellbore casing 1000 and open hole wellbore section 1005 is optimally fluidically sealed.

As illustrated in FIG. 10b, in a preferred embodiment, a quantity of a non-hardenable fluidic material is then injected into and then out of the apparatus 1015. In a preferred embodiment, the non-hardenable material is discharged from the apparatus 1015 using the valveable flow passage 1065. The non-hardenable fluidic material may be any number of conventional commercially available fluidic materials such as, for example, drilling mud.

As illustrated in FIG. 10c, in a preferred embodiment, a quantity of a hardenable fluidic sealing material is then injected into and out of the apparatus 1015. In a preferred embodiment, the hardenable fluidic sealing material is exhausted from the apparatus 1015 using the valveable flow passage 1065. In a preferred embodiment, the hardenable fluidic sealing material is permitted to completely fill the annular space between the tubular member 1040 and the open hole wellbore section 1005. The hardenable fluidic sealing material may be any number of conventional commercially available materials such as, for example, cement, slag mix and/or epoxy resin. In this manner, a fluidic sealing annular element is provided around the radially expanded tubular member 1040.

As illustrated in FIG. 10d, in a preferred embodiment, another quantity of a non-hardenable fluidic material is then injected into and out of the apparatus 1015. In a preferred embodiment, a ball plug or dart 1080, or other similar fluid passage blocking device, is placed into the non-hardenable fluid material. In a preferred embodiment, the ball plug 1080 then seats in and seals off the valveable fluid passage 1065. In this manner, the anchoring device 1035 is then pressurized to anchor the tubular member 1040 to the open hole wellbore section 1005.

In an alternative embodiment, the valveable fluid passage 1065 includes a remote or pressure activated valve for sealing off the valveable fluid passage 1065.

As illustrated in FIG. 10e, in a preferred embodiment, the apparatus 1015 is then anchored to the open hole wellbore section 1005 using the anchoring device 1035. In a preferred embodiment, the anchoring device 1035 is pressurized and the expandable element 1060 is radially extended from the anchoring device 1035 causing the flexible coupling element 1055 to radially expand into intimate contact



---  
with the walls of the open hole wellbore section 1005. In this manner, the lower section 1065 of the expandable tubular member 1040 is removably coupled to the walls of the open hole wellbore section 1005.

5 As illustrated in FIG. 10f, the expansion cone 1030 is then axially displaced by applying an axial force to the second support member 1025. In a preferred embodiment, the axial displacement of the expansion cone 1030 radially expands the expandable tubular member 1040 into intimate contact with the walls of the open hole wellbore section 1005.

10 In an alternative embodiment, as illustrated in FIG. 10g, the axial displacement of the expansion cone 1030 is enhanced by injecting a pressurized fluidic material into the annular space between the first support member 1020 and the second support member 1025. In this manner, an upward axial force is applied to the lower annular face of the expansion cone 1030 using the pressurized fluidic material. In this manner, a temporary need for increased axial force during the  
15 radial expansion process can be easily satisfied.

In a preferred embodiment, the hardenable fluidic sealing material is then permitted to at least partial cure.

20 As illustrated in FIGS. 10h and 10i, after the expandable tubular member 1040 has been radially expanded by the axial displacement of the expansion cone 1030, the first support member 1020 and the anchoring device 1035 are preferably removed from expandable tubular member 1040 by de-pressurizing the anchoring device 1035 and then lifting the first support member 1020 and anchoring device 1035 from the wellbore casing 1000 and the open hole wellbore section 1005.

25 In a preferred embodiment, the resulting new section of wellbore casing includes the radially expanded tubular member 1040 and the outer annular layer of the cured fluidic sealing material. In this manner, a new section of wellbore casing is optimally provided. More generally, the apparatus 1015 is used to form and/or repair wellbore casings, pipelines, and structural supports.

30 Referring to FIGS. 11a to 11g, an alternative embodiment of an apparatus and method for coupling an expandable tubular member to a preexisting structure will now be described. Referring to Fig. 11a, a wellbore casing 1100 is positioned within a subterranean formation 1105. The wellbore casing 1100 may be positioned in any orientation from the vertical direction to the horizontal direction. The wellbore casing 1100 further includes one or more openings 1110 that may have been the  
35 result of unintentional damage to the wellbore casing 1100, or due to a prior

perforation or fracturing operation performed upon the surrounding subterranean formation 1105. As will be recognized by persons having ordinary skill in the art, the openings 1110 can adversely affect the subsequent operation and use of the wellbore casing 1100 unless they are sealed off.

5 In a preferred embodiment, an apparatus 1115 is utilized to seal off the openings 1110 in the wellbore casing 1100. More generally, the apparatus 1115 is preferably utilized to form or repair wellbore casings, pipelines, or structural supports.

The apparatus 1115 preferably includes a first support member 1120, a  
10 second support member 1125, an expansion cone 1130, an anchoring device 1135, and expandable tubular member 1140, and one or more sealing members 1145.

The first support member 1120 is preferably adapted to be coupled to a surface location. The first support member 1120 is further coupled to the anchoring device 1135. The first support member 1120 is preferably adapted to convey  
15 pressurized fluidic materials and/or electrical current and/or communication signals from a surface location to the anchoring device 1135. The first support member 1120 preferably has a substantially hollow annular cross sectional shape. The first support member 1120 may, for example, be fabricated from conventional commercially available slick wire, braided wire, coiled tubing, or drilling stock  
20 material.

The second support member 1125 is preferably adapted to be coupled to a surface location. The second support member 1125 is further coupled to the expansion cone 1130. The second support member 1125 is preferably adapted to permit the expansion cone 1130 to be axially displaced relative to the first support  
25 member 1120. The second support member 1125 may, for example, be conventional commercially available slick wire, braided wire, coiled tubing, or drilling stock material.

In a preferred embodiment, the first support member 1120 is coupled to a surface location by a slip joint and/or sliding sleeve apparatus that is concentrically  
30 coupled to the second support member 1125.

The expansion cone 1130 is coupled to the second support member 1125. The expansion cone 1130 is preferably adapted to radially expand the expandable tubular member 1140 when the expansion cone 1130 is axially displaced relative to the expandable tubular member 1140. In a preferred embodiment, the expansion  
35 cone 1130 is provided substantially as disclosed in one or more of the following: (1)

U.S. utility patent application serial no. 09/454,139, attorney docket no. 25791.3.02, filed on 12/3/1999, which claimed the benefit of the filing date of U.S. provisional patent application no. 60/111,293, attorney docket no. 25791.3, filed on 12/7/1998;

5 (2) U.S. utility patent application serial no. 09/510,913, attorney docket no. 25791.7.02, filed on 2/23/2000, which claimed the benefit of the filing date of U.S. provisional application no. 60/121,702, filed on 2/25/1999; (3) U.S. utility patent application serial no. 09/502,350, attorney docket no. 25791.8.02, filed on 2/10/2000, which claimed the benefit of the filing date of U.S. provisional application no. 60/119,611, attorney docket no. 25791.8; (4) U.S. utility patent application serial

10 no. 09/440,338, attorney docket no. 25791.9.02, filed on 11/15/1999, which claimed the benefit of the filing date of U.S. provisional application no. 60/108,558, attorney docket no. 25791.9, filed on 11/16.1998; (5) U.S. provisional patent application no. 60/183,546, filed on 2/18/2000; (6) U.S. utility patent application no. 09/523,460, attorney docket no. 25791.11.02, filed on 3/10/2000, which claimed the benefit of

15 the filing date of U.S. provisional application no. 60/124,042, filed on 3/11/1999; (7) U.S. utility patent application no. 09/512,895, attorney docket no. 25791.12.02, filed on 2/24/2000, which claimed the benefit of the filing dates of U.S. provisional application no. 60/121,841, attorney docket no. 25791.12, filed on 2/26/1999 and U.S. provisional application no. 60/154,047, attorney docket no. 25791.29, filed on

20 9/16/1999; (8) U.S. utility application no. 09/511,941, attorney docket no. 25791.16.02, filed on 2/24/2000, which claimed the benefit of the filing date of U.S. provisional serial no. 60/121,907, attorney docket no. 25791.16, filed on 2/26/1999; (9) U.S. utility patent application no. 09/588,946, attorney docket no. 25791.17.02, filed on June 7, 2000, which claimed the benefit of the filing date of U.S. provisional

25 patent application serial no. 60/137,998, attorney docket no. 25791.17, filed on 6/7/1999; (10) U.S. utility patent application no. 09/559,122, attorney docket no. 25791.23.02, filed on 4/26/2000, which claimed the benefit of the filing date of U.S. provisional application no. 60/131,106, attorney docket no. 25791.23, filed on 4/26/1999; (11) U.S. provisional application no. 60/146,203, attorney docket no.

30 25791.25, filed on 7/29/1999; (12) U.S. provisional application no. 60/143,039, attorney docket no. 25791.26, filed on 7/9/1999; (13) U.S. provisional patent application serial no. 60/162,671, attorney docket no. 25791.27, filed on 11/1/1999; (14) U.S. provisional application no. 60/159,039, attorney docket no. 25791.36, filed on 10/12,1999; (15) U.S. provisional patent application no. 60/159,033, attorney

35 docket no. 25791.37, filed on 10/12/1999; and (16) U.S. provisional patent

application no. 60/165,228, attorney docket no. 25791.39, filed on 11/12/1999, the disclosures of which are incorporated herein by reference.

The anchoring device 1135 is coupled to the first support member 1120. The anchoring device 1135 is preferably adapted to be controllably coupled to the expandable tubular member 1140 and the wellbore casing 1100. In this manner, the anchoring device 1135 preferably controllably anchors the expandable tubular member 1140 to the wellbore casing 1100 to facilitate the radial expansion of the expandable tubular member 1140 by the axial displacement of the expansion cone 1130. In a preferred embodiment, the anchoring device 1135 includes one or more expandable elements 1150 that are adapted to controllably extend from the body of the anchoring device 1135 to engage both the expandable tubular member 1140 and the wellbore casing 1100. In a preferred embodiment, the expandable elements 1150 are actuated using fluidic pressure. In a preferred embodiment, the anchoring device 1135 is any one of the hydraulically actuated packers commercially available from Halliburton Energy Services or Baker-Hughes modified in accordance with the teachings of the present disclosure.

The expandable tubular member 1140 is removably coupled to the expansion cone 1130. The expandable tubular member 1140 is further preferably adapted to be removably coupled to the expandable elements 1150 of the anchoring device 1135. In a preferred embodiment, the expandable tubular member 1140 includes one or more anchoring windows 1155 for permitting the expandable elements 1150 of the anchoring device 1135 to engage the wellbore casing 1100 and the expandable tubular member 1140.

In a preferred embodiment, the expandable tubular member 1140 further includes a lower section 1160, an intermediate section 1165, and an upper section 1170. In a preferred embodiment, the lower section 1160 rests upon and is supported by the expansion cone 1130. In a preferred embodiment, the intermediate section 1165 includes the anchoring windows 1155 in order to provide anchoring at an intermediate portion of the expandable tubular member 1140.

In a preferred embodiment, the expandable tubular member 1140 is further provided substantially as disclosed in one or more of the following: (1) U.S. utility patent application serial no. 09/454,139, attorney docket no. 25791.3.02, filed on 12/3/1999, which claimed the benefit of the filing date of U.S. provisional patent application no. 60/111,293, attorney docket no. 25791.3, filed on 12/7/1998; (2) U.S. utility patent application serial no. 09/510,913, attorney docket no. 25791.7.02, filed

on 2/23/2000, which claimed the benefit of the filing date of U.S. provisional application no. 60/121,702, filed on 2/25/1999; (3) U.S. utility patent application serial no. 09/502,350, attorney docket no. 25791.8.02, filed on 2/10/2000, which claimed the benefit of the filing date of U.S. provisional application no. 60/119,611, attorney docket no. 25791.8; (4) U.S. utility patent application serial no. 09/440,338, attorney docket no. 25791.9.02, filed on 11/15/1999, which claimed the benefit of the filing date of U.S. provisional application no. 60/108,558, attorney docket no. 25791.9, filed on 11/16.1998; (5) U.S. provisional patent application no. 60/183,546, filed on 2/18/2000; (6) U.S. utility patent application no. 09/523,460, attorney docket no. 25791.11.02, filed on 3/10/2000, which claimed the benefit of the filing date of U.S. provisional application no. 60/124,042, filed on 3/11/1999; (7) U.S. utility patent application no. 09/512,895, attorney docket no. 25791.12.02, filed on 2/24/2000, which claimed the benefit of the filing dates of U.S. provisional application no. 60/121,841, attorney docket no. 25791.12, filed on 2/26/1999 and U.S. provisional application no. 60/154,047, attorney docket no. 25791.29, filed on 9/16/1999; (8) U.S. utility application no. 09/511,941, attorney docket no. 25791.16.02, filed on 2/24/2000, which claimed the benefit of the filing date of U.S. provisional serial no. 60/121,907, attorney docket no. 25791.16, filed on 2/26/1999; (9) U.S. utility patent application no. 09/588,946, attorney docket no. 25791.17.02, filed on June 7, 2000, which claimed the benefit of the filing date of U.S. provisional patent application serial no. 60/137,998, attorney docket no. 25791.17, filed on 6/7/1999; (10) U.S. utility patent application no. 09/559,122, attorney docket no. 25791.23.02, filed on 4/26/2000, which claimed the benefit of the filing date of U.S. provisional application no. 60/131,106, attorney docket no. 25791.23, filed on 4/26/1999; (11) U.S. provisional application no. 60/146,203, attorney docket no. 25791.25, filed on 7/29/1999; (12) U.S. provisional application no. 60/143,039, attorney docket no. 25791.26, filed on 7/9/1999; (13) U.S. provisional patent application serial no. 60/162,671, attorney docket no. 25791.27, filed on 11/1/1999; (14) U.S. provisional application no. 60/159,039, attorney docket no. 25791.36, filed on 10/12,1999; (15) U.S. provisional patent application no. 60/159,033, attorney docket no. 25791.37, filed on 10/12/1999; and (16) U.S. provisional patent application no. 60/165,228, attorney docket no. 25791.39, filed on 11/12/1999, the disclosures of which are incorporated herein by reference.

The sealing members 1145 are coupled to the outer surface of the expandable tubular member 1140. The sealing members 1145 are preferably

adapted to engage and fluidically seal the interface between the radially expanded expandable tubular member 1140 and the wellbore casing 1100. In a preferred embodiment, the apparatus 1115 includes a plurality of sealing members 1145. In a preferred embodiment, the sealing members 1145 surround and isolate the opening  
5 1110.

As illustrated in FIG. 11a, the apparatus 1115 is preferably positioned within the wellbore casing 1100 with the expandable tubular member 1140 positioned in opposing relation to the opening 1110. In a preferred embodiment, the apparatus 1115 includes a plurality of sealing members 1145 that are positioned above and  
10 below the opening 1110. In this manner, the radial expansion of the expandable tubular member 1140 optimally fluidically isolates the opening 1110.

As illustrated in FIG. 11b, the apparatus 1115 is then anchored to the wellbore casing 1100 using the anchoring device 1135. In a preferred embodiment, the anchoring device 1135 is pressurized and the expandable element 1150 is  
15 extended from the anchoring device 1135 through the corresponding anchoring window 1155 in the expandable tubular member 1140 into intimate contact with the wellbore casing 1100. In this manner, the intermediate section 1165 of the expandable tubular member 1140 is removably coupled to the wellbore casing 1100.

In an alternative embodiment, a compressible cement and/or epoxy is then  
20 injected into at least a portion of the annular space between the unexpanded portion of the tubular member 1140 and the wellbore casing 1100. The compressible cement and/or epoxy is then permitted to at least partially cure prior to the initiation of the radial expansion process. In this manner, an annular structural support and fluidic seal is provided around the tubular member 1140.

As illustrated in FIG. 11c, in a preferred embodiment, the expansion cone  
25 1130 is then axially displaced by applying an axial force to the second support member 1125. In a preferred embodiment, the axial displacement of the expansion cone 1130 radially expands the lower section 1160 of the expandable tubular member 1140 into intimate contact with the walls of the wellbore or the wellbore  
30 casing 1100.

As illustrated in FIG. 11d, in a preferred embodiment, the axial displacement of the expansion cone 1130 is stopped once the expansion cone 1130 contacts the lower portion of the anchoring device 1135.

As illustrated in FIG. 11e, in a preferred embodiment, the anchoring device 1135 is then decoupled from the wellbore casing 1100 and the expandable tubular member 1140.

5 As illustrated in FIG. 11f, in a preferred embodiment, the axial displacement of the expansion cone 1130 is then resumed. In a preferred embodiment, the anchoring device 1135 is also axial displaced. In this manner, the lower section 1160 of the expandable tubular member 1140 is self-anchored to the wellbore casing 1100. In a preferred embodiment, the lower section 1160 of the expandable tubular member 1140 includes one or more outer rings or other coupling members  
10 to facilitate the self-anchoring of the lower section 1160 of the expandable tubular member 1140 to the wellbore or the wellbore casing 1100.

As illustrated in FIGS. 11g, after the expandable tubular member 1140 has been completely radially expanded by the axial displacement of the expansion cone 1130, the 1110 in the wellbore casing 1100 is sealed off by the radially expanded  
15 tubular member 1140. In this manner, repairs to the wellbore casing 1100 are optimally provided. More generally, the apparatus 1115 is used to repair or form wellbore casings, pipelines, and structural supports. In a preferred embodiment, the inside diameter of the radially expanded tubular member 1140 is substantially constant.

20 Referring to FIGS. 12a to 12d, an alternative embodiment of an apparatus and method for coupling an expandable tubular member to a preexisting structure will now be described. Referring to Fig. 12a, a wellbore casing 1200 is positioned within a subterranean formation 1205. The wellbore casing 1200 may be positioned in any orientation from the vertical direction to the horizontal direction. The wellbore casing 1200 further includes one or more openings 1210 that may have been the  
25 result of unintentional damage to the wellbore casing 1200, or due to a prior perforation or fracturing operation performed upon the surrounding subterranean formation 1205. As will be recognized by persons having ordinary skill in the art, the openings 1210 can adversely affect the subsequent operation and use of the wellbore casing 1200 unless they are sealed off.  
30

In a preferred embodiment, an apparatus 1215 is utilized to seal off the openings 1210 in the wellbore casing 1200. More generally, the apparatus 1215 is preferably utilized to form or repair wellbore casings, pipelines, or structural supports.

The apparatus 1215 preferably includes a support member 1220, an expandable expansion cone 1225, an expandable tubular member 1235, and one or more sealing members 1240.

5 The support member 1220 is preferably adapted to be coupled to a surface location. The support member 1220 is further coupled to the expandable expansion cone 1225. The support member 320 is preferably adapted to convey pressurized fluidic materials and/or electrical current and/or communication signals from a surface location to the expandable expansion cone. The support member 1220 may, for example, be conventional commercially available slick wire, braided wire,  
10 coiled tubing, or drilling stock material.

The expandable expansion cone 1225 is coupled to the support member 1220. The expandable expansion cone 1225 is preferably adapted to radially expand the expandable tubular member 1235 when the expandable expansion cone 1225 is axially displaced relative to the expandable tubular member 1235. The  
15 expandable expansion cone 1225 is further preferably adapted to radially expand at least a portion of the expandable tubular member 1235 when the expandable expansion cone 1225 is controllably radially expanded. The expandable expansion cone 1225 may be any number of conventional commercially available radially expandable expansion cones. In a preferred embodiment, the expandable  
20 expansion cone 1225 is provided substantially as disclosed in U.S. Patent No. 5,348,095, the disclosure of which is incorporated herein by reference.

In a preferred embodiment, the expansion cone 1225 is further provided substantially as disclosed in one or more of the following: (1) U.S. utility patent application serial no. 09/454,139, attorney docket no. 25791.3.02, filed on  
25 12/3/1999, which claimed the benefit of the filing date of U.S. provisional patent application no. 60/111,293, attorney docket no. 25791.3, filed on 12/7/1998; (2) U.S. utility patent application serial no. 09/510,913, attorney docket no. 25791.7.02, filed on 2/23/2000, which claimed the benefit of the filing date of U.S. provisional application no. 60/121,702, filed on 2/25/1999; (3) U.S. utility patent application  
30 serial no. 09/502,350, attorney docket no. 25791.8.02, filed on 2/10/2000, which claimed the benefit of the filing date of U.S. provisional application no. 60/119,611, attorney docket no. 25791.8; (4) U.S. utility patent application serial no. 09/440,338, attorney docket no. 25791.9.02, filed on 11/15/1999, which claimed the benefit of the filing date of U.S. provisional application no. 60/108,558, attorney docket no.  
35 25791.9, filed on 11/16.1998; (5) U.S. provisional patent application no. 60/183,546,



filed on 2/18/2000; (6) U.S. utility patent application no. 09/523,460, attorney docket no. 25791.11.02, filed on 3/10/2000, which claimed the benefit of the filing date of U.S. provisional application no. 60/124,042, filed on 3/11/1999; (7) U.S. utility patent application no. 09/512,895, attorney docket no. 25791.12.02, filed on 2/24/2000, which claimed the benefit of the filing dates of U.S. provisional application no. 60/121,841, attorney docket no. 25791.12, filed on 2/26/1999 and U.S. provisional application no. 60/154,047, attorney docket no. 25791.29, filed on 9/16/1999; (8) U.S. utility application no. 09/511,941, attorney docket no. 25791.16.02, filed on 2/24/2000, which claimed the benefit of the filing date of U.S. provisional serial no. 60/121,907, attorney docket no. 25791.16, filed on 2/26/1999; (9) U.S. utility patent application no. 09/588,946, attorney docket no. 25791.17.02, filed on June 7, 2000, which claimed the benefit of the filing date of U.S. provisional patent application serial no. 60/137,998, attorney docket no. 25791.17, filed on 6/7/1999; (10) U.S. utility patent application no. 09/559,122, attorney docket no. 25791.23.02, filed on 4/26/2000, which claimed the benefit of the filing date of U.S. provisional application no. 60/131,106, attorney docket no. 25791.23, filed on 4/26/1999; (11) U.S. provisional application no. 60/146,203, attorney docket no. 25791.25, filed on 7/29/1999; (12) U.S. provisional application no. 60/143,039, attorney docket no. 25791.26, filed on 7/9/1999; (13) U.S. provisional patent application serial no. 60/162,671, attorney docket no. 25791.27, filed on 11/1/1999; (14) U.S. provisional application no. 60/159,039, attorney docket no. 25791.36, filed on 10/12,1999; (15) U.S. provisional patent application no. 60/159,033, attorney docket no. 25791.37, filed on 10/12/1999; and (16) U.S. provisional patent application no. 60/165,228, attorney docket no. 25791.39, filed on 11/12/1999, the disclosures of which are incorporated herein by reference.

The expandable tubular member 1235 is removably coupled to the expansion cone 1225. In a preferred embodiment, the expandable tubular member 1235 includes one or more engagement devices 1250 that are adapted to couple with and penetrate the wellbore casing 1200. In this manner, the expandable tubular member 1235 is optimally coupled to the wellbore casing 1200. In a preferred embodiment, the engagement devices 1250 include teeth for biting into the surface of the wellbore casing 1200.

In a preferred embodiment, the expandable tubular member 1235 further includes a lower section 1255, an intermediate section 1260, and an upper section 1265. In a preferred embodiment, the lower section 1255 includes the engagement

devices 1250 in order to provide anchoring at an end portion of the expandable tubular member 1235. In a preferred embodiment, the wall thickness of the lower and intermediate sections, 1255 and 1260, are less than the wall thickness of the upper section 1265 in order to optimally facilitate the radial expansion of the lower and intermediate sections, 1255 and 1260, of the expandable tubular member 1235. In an alternative embodiment, the lower section 1255 of the expandable tubular member 1235 is slotted in order to optimally facilitate the radial expansion of the lower section 1255 of the expandable tubular member 1235 using the expandable expansion cone 1225.

In a preferred embodiment, the expandable tubular member 1235 is further provided substantially as disclosed in one or more of the following: (1) U.S. utility patent application serial no. 09/454,139, attorney docket no. 25791.3.02, filed on 12/3/1999, which claimed the benefit of the filing date of U.S. provisional patent application no. 60/111,293, attorney docket no. 25791.3, filed on 12/7/1998; (2) U.S. utility patent application serial no. 09/510,913, attorney docket no. 25791.7.02, filed on 2/23/2000, which claimed the benefit of the filing date of U.S. provisional application no. 60/121,702, filed on 2/25/1999; (3) U.S. utility patent application serial no. 09/502,350, attorney docket no. 25791.8.02, filed on 2/10/2000, which claimed the benefit of the filing date of U.S. provisional application no. 60/119,611, attorney docket no. 25791.8; (4) U.S. utility patent application serial no. 09/440,338, attorney docket no. 25791.9.02, filed on 11/15/1999, which claimed the benefit of the filing date of U.S. provisional application no. 60/108,558, attorney docket no. 25791.9, filed on 11/16.1998; (5) U.S. provisional patent application no. 60/183,546, filed on 2/18/2000; (6) U.S. utility patent application no. 09/523,460, attorney docket no. 25791.11.02, filed on 3/10/2000, which claimed the benefit of the filing date of U.S. provisional application no. 60/124,042, filed on 3/11/1999; (7) U.S. utility patent application no. 09/512,895, attorney docket no. 25791.12.02, filed on 2/24/2000, which claimed the benefit of the filing dates of U.S. provisional application no. 60/121,841, attorney docket no. 25791.12, filed on 2/26/1999 and U.S. provisional application no. 60/154,047, attorney docket no. 25791.29, filed on 9/16/1999; (8) U.S. utility application no. 09/511,941, attorney docket no. 25791.16.02, filed on 2/24/2000, which claimed the benefit of the filing date of U.S. provisional serial no. 60/121,907, attorney docket no. 25791.16, filed on 2/26/1999; (9) U.S. utility patent application no. 09/588,946, attorney docket no. 25791.17.02, filed on June 7, 2000, which claimed the benefit of the filing date of U.S. provisional patent application

serial no. 60/137,998, attorney docket no. 25791.17, filed on 6/7/1999; (10) U.S. utility patent application no. 09/559,122, attorney docket no. 25791.23.02, filed on 4/26/2000, which claimed the benefit of the filing date of U.S. provisional application no. 60/131,106, attorney docket no. 25791.23, filed on 4/26/1999; (11) U.S. provisional application no. 60/146,203, attorney docket no. 25791.25, filed on 7/29/1999; (12) U.S. provisional application no. 60/143,039, attorney docket no. 25791.26, filed on 7/9/1999; (13) U.S. provisional patent application serial no. 60/162,671, attorney docket no. 25791.27, filed on 11/1/1999; (14) U.S. provisional application no. 60/159,039, attorney docket no. 25791.36, filed on 10/12,1999; (15) U.S. provisional patent application no. 60/159,033, attorney docket no. 25791.37, filed on 10/12/1999; and (16) U.S. provisional patent application no. 60/165,228, attorney docket no. 25791.39, filed on 11/12/1999, the disclosures of which are incorporated herein by reference.

The sealing members 1240 are preferably coupled to the outer surface of the upper portion 1265 of the expandable tubular member 1235. The sealing members 1240 are preferably adapted to engage and fluidically seal the interface between the radially expanded expandable tubular member 1235 and the wellbore casing 1200. In a preferred embodiment, the apparatus 1215 includes a plurality of sealing members 1240. In a preferred embodiment, the sealing members 1240 surround and isolate the opening 1210.

As illustrated in FIG. 12a, the apparatus 1215 is preferably positioned within the wellbore casing 1200 with the expandable tubular member 1235 positioned in opposing relation to the opening 1210. In a preferred embodiment, the apparatus 1215 includes a plurality of sealing members 1240 that are positioned above and below the opening 1210. In this manner, the radial expansion of the expandable tubular member 1235 optimally fluidically isolates the opening 1210.

As illustrated in FIG. 12b, the expandable tubular member 1235 of the apparatus 1215 is then anchored to the wellbore casing 1200 by expanding the expandable expansion cone 1225 into contact with the lower section 1255 of the expandable tubular member 1235. In a preferred embodiment, the lower section 1255 of the expandable tubular member 1235 is radially expanded into intimate contact with the wellbore casing 1200. In a preferred embodiment, the engagement devices 1250 are thereby coupled to, and at least partially penetrate into, the wellbore casing 1200. In this manner, the lower section 1255 of the expandable tubular member 1235 is optimally coupled to the wellbore casing 1200.

In an alternative embodiment, a compressible cement and/or epoxy is then injected into the annular space between the unexpanded portion of the tubular member 1235 and the wellbore casing 1200. The compressible cement and/or epoxy may then be permitted to at least partially cure prior to the initiation of the radial expansion process. In this manner, an annular structural support and fluidic seal is provided around the tubular member 1235.

As illustrated in FIG. 12c, the expandable expansion cone 1225 is then axially displaced by applying an axial force to the support member 1220. In a preferred embodiment, the axial displacement of the expansion cone 1225 radially expands the expandable tubular member 1235 into intimate contact with the walls of the wellbore casing 1200.

As illustrated in FIG. 12d, in a preferred embodiment, after the expandable tubular member 1235 has been radially expanded by the axial displacement of the expandable expansion cone 1235, the opening 1210 in the wellbore casing 1200 is sealed off by the radially expanded tubular member 1235. In this manner, repairs to the wellbore casing 1200 are optimally provided. More generally, the apparatus 1215 is used to repair or form wellbore casings, pipelines, and structural supports.

Referring to FIGS. 13a to 13d, an alternative embodiment of an apparatus and method for coupling an expandable tubular member to a preexisting structure will now be described. Referring to Fig. 13a, a wellbore casing 1300 is positioned within a subterranean formation 1305. The wellbore casing 1300 may be positioned in any orientation from the vertical direction to the horizontal direction. The wellbore casing 1300 further includes one or more openings 1310 that may have been the result of unintentional damage to the wellbore casing 1300, or due to a prior perforation or fracturing operation performed upon the surrounding subterranean formation 1305. As will be recognized by persons having ordinary skill in the art, the openings 1310 can adversely affect the subsequent operation and use of the wellbore casing 1300 unless they are sealed off.

In a preferred embodiment, an apparatus 1315 is utilized to seal off the openings 1310 in the wellbore casing 1300. More generally, the apparatus 1315 is preferably utilized to form or repair wellbore casings, pipelines, or structural supports.

The apparatus 1315 preferably includes a support member 1320, an expansion cone 1325, an expandable tubular member 1335, a heater 1340, and one or more sealing members 1345.

The support member 1320 is preferably adapted to be coupled to a surface location. The support member 1320 is further coupled to the expansion cone 1325. The support member 1320 is preferably adapted to convey pressurized fluidic materials and/or electrical current and/or communication signals from a surface  
5 location to the expansion cone 1325 and heater 1340. The support member 1320 may, for example, be conventional commercially available slick wire, braided wire, coiled tubing, or drilling stock material.

The expansion cone 1325 is coupled to the support member 1320. The expansion cone 1325 is preferably adapted to radially expand the expandable  
10 tubular member 1335 when the expansion cone 1325 is axially displaced relative to the expandable tubular member 1335. The expansion cone 1325 may be any number of conventional commercially available expansion cones.

In a preferred embodiment, the expansion cone 1325 is further provided substantially as disclosed in one or more of the following: (1) U.S. utility patent  
15 application serial no. 09/454,139, attorney docket no. 25791.3.02, filed on 12/3/1999, which claimed the benefit of the filing date of U.S. provisional patent application no. 60/111,293, attorney docket no. 25791.3, filed on 12/7/1998; (2) U.S. utility patent application serial no. 09/510,913, attorney docket no. 25791.7.02, filed on 2/23/2000, which claimed the benefit of the filing date of U.S. provisional  
20 application no. 60/121,702, filed on 2/25/1999; (3) U.S. utility patent application serial no. 09/502,350, attorney docket no. 25791.8.02, filed on 2/10/2000, which claimed the benefit of the filing date of U.S. provisional application no. 60/119,611, attorney docket no. 25791.8; (4) U.S. utility patent application serial no. 09/440,338, attorney docket no. 25791.9.02, filed on 11/15/1999, which claimed the benefit of  
25 the filing date of U.S. provisional application no. 60/108,558, attorney docket no. 25791.9, filed on 11/16.1998; (5) U.S. provisional patent application no. 60/183,546, filed on 2/18/2000; (6) U.S. utility patent application no. 09/523,460, attorney docket no. 25791.11.02, filed on 3/10/2000, which claimed the benefit of the filing date of U.S. provisional application no. 60/124,042, filed on 3/11/1999; (7) U.S. utility patent  
30 application no. 09/512,895, attorney docket no. 25791.12.02, filed on 2/24/2000, which claimed the benefit of the filing dates of U.S. provisional application no. 60/121,841, attorney docket no. 25791.12, filed on 2/26/1999 and U.S. provisional application no. 60/154,047, attorney docket no. 25791.29, filed on 9/16/1999; (8) U.S. utility application no. 09/511,941, attorney docket no. 25791.16.02, filed on  
35 2/24/2000, which claimed the benefit of the filing date of U.S. provisional serial no.

60/121,907, attorney docket no. 25791.16, filed on 2/26/1999; (9) U.S. utility patent application no. 09/588,946, attorney docket no. 25791.17.02, filed on June 7, 2000, which claimed the benefit of the filing date of U.S. provisional patent application serial no. 60/137,998, attorney docket no. 25791.17, filed on 6/7/1999; (10) U.S. utility patent application no. 09/559,122, attorney docket no. 25791.23.02, filed on 4/26/2000, which claimed the benefit of the filing date of U.S. provisional application no. 60/131,106, attorney docket no. 25791.23, filed on 4/26/1999; (11) U.S. provisional application no. 60/146,203, attorney docket no. 25791.25, filed on 7/29/1999; (12) U.S. provisional application no. 60/143,039, attorney docket no. 25791.26, filed on 7/9/1999; (13) U.S. provisional patent application serial no. 60/162,671, attorney docket no. 25791.27, filed on 11/1/1999; (14) U.S. provisional application no. 60/159,039, attorney docket no. 25791.36, filed on 10/12,1999; (15) U.S. provisional patent application no. 60/159,033, attorney docket no. 25791.37, filed on 10/12/1999; and (16) U.S. provisional patent application no. 60/165,228, attorney docket no. 25791.39, filed on 11/12/1999, the disclosures of which are incorporated herein by reference.

The expandable tubular member 1335 is removably coupled to the expansion cone 1325. In a preferred embodiment, the expandable tubular member 1335 includes one or more engagement devices 1350 that are adapted to couple with and penetrate the wellbore casing 1300. In this manner, the expandable tubular member 1335 is optimally coupled to the wellbore casing 1300. In a preferred embodiment, the engagement devices 1350 include teeth for biting into the surface of the wellbore casing 1300.

In a preferred embodiment, the expandable tubular member 1335 further includes a lower section 1355, an intermediate section 1360, and an upper section 1365. In a preferred embodiment, the lower section 1355 includes the engagement devices 1350 in order to provide anchoring at an end portion of the expandable tubular member 1335. In a preferred embodiment, the wall thickness of the lower and intermediate sections, 1355 and 1360, are less than the wall thickness of the upper section 1365 in order to optimally facilitate the radial expansion of the lower and intermediate sections, 1355 and 1360, of the expandable tubular member 1335.

In a preferred embodiment, the lower section 1355 of the expandable tubular member 1335 includes one or more shape memory metal inserts 1370. In a preferred embodiment, the inserts 1370 are adapted to radially expand the lower section 1355 of the expandable tubular member 1335 into intimate contact with the

wellbore casing 1300 when heated by the heater 1340. The shape memory metal inserts 1370 may be fabricated from any number of conventional commercially available shape memory alloys such as, for example, NiTi or NiTiNOL using conventional forming processes such as, for example, those described in U.S. Patent Nos. 5,312,152, 5,344,506, and 5,718,531, the disclosures of which are incorporated herein by reference. In this manner, the shape memory metal inserts 1370 preferably radially expand the lower section 1355 of the expandable tubular member 1335 when the inserts 1370 are heated to a temperature above their transformation temperature using the heater 1340. In a preferred embodiment, the transformation temperature of the inserts 1370 ranges from about 250° F to 450° F. In a preferred embodiment, the material composition of the lower section 1355 of the expandable tubular member 1335 is further selected to maximize the radial expansion of the lower section 1355 during the transformation process.

In a preferred embodiment, the inserts 1370 are positioned within one or more corresponding recesses 1375 provided in the lower section 1355 of the expandable tubular member 1335. Alternatively, the inserts 1370 are completely contained within the lower section 1355 of the expandable tubular member 1335.

In a preferred embodiment, the expandable tubular member 1335 is further provided substantially as disclosed in one or more of the following: (1) U.S. utility patent application serial no. 09/454,139, attorney docket no. 25791.3.02, filed on 12/3/1999, which claimed the benefit of the filing date of U.S. provisional patent application no. 60/111,293, attorney docket no. 25791.3, filed on 12/7/1998; (2) U.S. utility patent application serial no. 09/510,913, attorney docket no. 25791.7.02, filed on 2/23/2000, which claimed the benefit of the filing date of U.S. provisional application no. 60/121,702, filed on 2/25/1999; (3) U.S. utility patent application serial no. 09/502,350, attorney docket no. 25791.8.02, filed on 2/10/2000, which claimed the benefit of the filing date of U.S. provisional application no. 60/119,611, attorney docket no. 25791.8; (4) U.S. utility patent application serial no. 09/440,338, attorney docket no. 25791.9.02, filed on 11/15/1999, which claimed the benefit of the filing date of U.S. provisional application no. 60/108,558, attorney docket no. 25791.9, filed on 11/16.1998; (5) U.S. provisional patent application no. 60/183,546, filed on 2/18/2000; (6) U.S. utility patent application no. 09/523,460, attorney docket no. 25791.11.02, filed on 3/10/2000, which claimed the benefit of the filing date of U.S. provisional application no. 60/124,042, filed on 3/11/1999; (7) U.S. utility patent application no. 09/512,895, attorney docket no. 25791.12.02, filed on 2/24/2000,

which claimed the benefit of the filing dates of U.S. provisional application no. 60/121,841, attorney docket no. 25791.12, filed on 2/26/1999 and U.S. provisional application no. 60/154,047, attorney docket no. 25791.29, filed on 9/16/1999; (8) U.S. utility application no. 09/511,941, attorney docket no. 25791.16.02, filed on  
5 2/24/2000, which claimed the benefit of the filing date of U.S. provisional serial no. 60/121,907, attorney docket no. 25791.16, filed on 2/26/1999; (9) U.S. utility patent application no. 09/588,946, attorney docket no. 25791.17.02, filed on June 7, 2000, which claimed the benefit of the filing date of U.S. provisional patent application serial no. 60/137,998, attorney docket no. 25791.17, filed on 6/7/1999; (10) U.S.  
10 utility patent application no. 09/559,122, attorney docket no. 25791.23.02, filed on 4/26/2000, which claimed the benefit of the filing date of U.S. provisional application no. 60/131,106, attorney docket no. 25791.23, filed on 4/26/1999; (11) U.S. provisional application no. 60/146,203, attorney docket no. 25791.25, filed on 7/29/1999; (12) U.S. provisional application no. 60/143,039, attorney docket no.  
15 25791.26, filed on 7/9/1999; (13) U.S. provisional patent application serial no. 60/162,671, attorney docket no. 25791.27, filed on 11/1/1999; (14) U.S. provisional application no. 60/159,039, attorney docket no. 25791.36, filed on 10/12,1999; (15) U.S. provisional patent application no. 60/159,033, attorney docket no. 25791.37, filed on 10/12/1999; and (16) U.S. provisional patent application no. 60/165,228,  
20 attorney docket no. 25791.39, filed on 11/12/1999, the disclosures of which are incorporated herein by reference.

The heater 1340 is coupled to the support member 1320. The heater 1340 is preferably adapted to controllably generate a localized heat source for elevating the temperature of the inserts 1370. In a preferred embodiment, the heater 1340  
25 includes a conventional thermostat control in order to control the operating temperature. The heater 1340 is preferably controlled by a surface control device in a conventional manner.

The sealing members 1345 are preferably coupled to the outer surface of the upper portion 1365 of the expandable tubular member 1335. The sealing members  
30 1345 are preferably adapted to engage and fluidically seal the interface between the radially expanded expandable tubular member 1335 and the wellbore casing 1300. In a preferred embodiment, the apparatus 1315 includes a plurality of sealing members 1345. In a preferred embodiment, the sealing members 1345 surround and isolate the opening 1310.



As illustrated in FIG. 13a, the apparatus 1315 is preferably positioned within the wellbore casing 1300 with the expandable tubular member 1335 positioned in opposing relation to the opening 1310. In a preferred embodiment, the apparatus 1315 includes a plurality of sealing members 1345 that are positioned above and below the opening 1310. In this manner, the radial expansion of the expandable tubular member 1335 optimally fluidically isolates the opening 1310.

As illustrated in FIG. 13b, in a preferred embodiment, the expandable tubular member 1335 of the apparatus 1315 is then anchored to the wellbore casing 1300 by radially expanding the inserts 1370 using the heater 1340. In a preferred embodiment, the expansion of the inserts 1370 causes the lower section 1355 of the expandable tubular member 1335 to contact the wellbore casing 1300. In a preferred embodiment, the engagement devices 1350 are thereby coupled to, and at least partially penetrate into, the wellbore casing 1300. In this manner, the lower section 1355 of the expandable tubular member 1335 is optimally coupled to the wellbore casing 1300.

In an alternative embodiment, a compressible cement and/or epoxy is then injected into the annular space between the unexpanded portion of the tubular member 1335 and the wellbore casing 1300. The compressible cement and/or epoxy may then be permitted to at least partially cure prior to the initiation of the radial expansion process. In this manner, an annular structural support and fluidic seal is provided around the tubular member 1335.

As illustrated in FIG. 13c, the expansion cone 1325 is then axially displaced by applying an axial force to the support member 1320. In a preferred embodiment, the axial displacement of the expansion cone 1325 radially expands the expandable tubular member 1335 into intimate contact with the walls of the wellbore casing 1300.

As illustrated in FIG. 13d, in a preferred embodiment, after the expandable tubular member 1335 has been completely radially expanded by the axial displacement of the expansion cone 1335, the opening 1310 in the wellbore casing 1300 is sealed off by the radially expanded tubular member 1335. In this manner, repairs to the wellbore casing 1300 are optimally provided. More generally, the apparatus 1315 is used to repair or form wellbore casings, pipelines, and structural supports.

Referring to FIGS. 14a to 14g, an alternative embodiment of an apparatus and method for coupling an expandable tubular member to a preexisting structure

will now be described. Referring to Fig. 14a, a wellbore casing 1400 is positioned within a subterranean formation 1405. The wellbore casing 1400 may be positioned in any orientation from the vertical direction to the horizontal direction. The wellbore casing 1400 further includes one or more openings 1410 that may have been the result of unintentional damage to the wellbore casing 1400, or due to a prior perforation or fracturing operation performed upon the surrounding subterranean formation 1405. As will be recognized by persons having ordinary skill in the art, the openings 1410 can adversely affect the subsequent operation and use of the wellbore casing 1400 unless they are sealed off.

10 In a preferred embodiment, an apparatus 1415 is utilized to seal off the openings 1410 in the wellbore casing 1400. More generally, the apparatus 1415 is preferably utilized to form or repair wellbore casings, pipelines, or structural supports.

The apparatus 1415 preferably includes a first support member 1420, a second support member 1425, a coupling 1430, an expandable tubular member 1435, an expansion cone 1440, a third support member 1445, and a packer 1450.

20 The first support member 1420 is preferably adapted to be coupled to a surface location. The support member 1420 is further coupled to the expansion cone 1440. The first support member 1420 is preferably adapted to convey pressurized fluidic materials and/or electrical current and/or communication signals from a surface location to the expansion cone 1440 and the packer 1450. The first support member 1420 may, for example, be conventional commercially available slick wire, braided wire, coiled tubing, or drilling stock material.

25 The second support member 1425 is preferably adapted to be coupled to a surface location. The support member 1425 is further coupled to the coupling 1430. The first support member 1425 is preferably adapted to convey pressurized fluidic materials and/or electrical current and/or communication signals from a surface location to the coupling 1430. The second support member 1425 may, for example, be conventional commercially available slick wire, braided wire, coiled tubing, or drilling stock material.

30 The coupling 1430 is coupled to the second support member 1425. The coupling 1430 is further preferably removably coupled to the expandable tubular member 1435. The coupling 1430 may be any number of conventional commercially available passive or actively controlled coupling devices such as, for

example, packers or slips. In a preferred embodiment, the coupling 1430 is a mechanical slip.

The expandable tubular member 1435 is removably coupled to the coupling 1430. In a preferred embodiment, the expandable tubular member 1435 includes  
5 one or more engagement devices that are adapted to couple with and penetrate the wellbore casing 1400. In this manner, the expandable tubular member 1435 is optimally coupled to the wellbore casing 1400. In a preferred embodiment, the engagement devices include teeth for biting into the surface of the wellbore casing 1400. In a preferred embodiment, the expandable tubular member 1435 further  
10 includes one or more sealing members on the outside surface of the expandable tubular member 1435 in order to optimally seal the interface between the expandable tubular member 1435 and the wellbore casing 1400.

In a preferred embodiment, the expandable tubular member 1435 is further provided substantially as disclosed in one or more of the following: (1) U.S. utility  
15 patent application serial no. 09/454,139, attorney docket no. 25791.3.02, filed on 12/3/1999, which claimed the benefit of the filing date of U.S. provisional patent application no. 60/111,293, attorney docket no. 25791.3, filed on 12/7/1998; (2) U.S. utility patent application serial no. 09/510,913, attorney docket no. 25791.7.02, filed on 2/23/2000, which claimed the benefit of the filing date of U.S. provisional  
20 application no. 60/121,702, filed on 2/25/1999; (3) U.S. utility patent application serial no. 09/502,350, attorney docket no. 25791.8.02, filed on 2/10/2000, which claimed the benefit of the filing date of U.S. provisional application no. 60/119,611, attorney docket no. 25791.8; (4) U.S. utility patent application serial no. 09/440,338, attorney docket no. 25791.9.02, filed on 11/15/1999, which claimed the benefit of  
25 the filing date of U.S. provisional application no. 60/108,558, attorney docket no. 25791.9, filed on 11/16.1998; (5) U.S. provisional patent application no. 60/183,546, filed on 2/18/2000; (6) U.S. utility patent application no. 09/523,460, attorney docket no. 25791.11.02, filed on 3/10/2000, which claimed the benefit of the filing date of U.S. provisional application no. 60/124,042, filed on 3/11/1999; (7) U.S. utility patent  
30 application no. 09/512,895, attorney docket no. 25791.12.02, filed on 2/24/2000, which claimed the benefit of the filing dates of U.S. provisional application no. 60/121,841, attorney docket no. 25791.12, filed on 2/26/1999 and U.S. provisional application no. 60/154,047, attorney docket no. 25791.29, filed on 9/16/1999; (8) U.S. utility application no. 09/511,941, attorney docket no. 25791.16.02, filed on  
35 2/24/2000, which claimed the benefit of the filing date of U.S. provisional serial no.

60/121,907, attorney docket no. 25791.16, filed on 2/26/1999; (9) U.S. utility patent application no. 09/588,946, attorney docket no. 25791.17.02, filed on June 7, 2000, which claimed the benefit of the filing date of U.S. provisional patent application serial no. 60/137,998, attorney docket no. 25791.17, filed on 6/7/1999; (10) U.S. utility patent application no. 09/559,122, attorney docket no. 25791.23.02, filed on 4/26/2000, which claimed the benefit of the filing date of U.S. provisional application no. 60/131,106, attorney docket no. 25791.23, filed on 4/26/1999; (11) U.S. provisional application no. 60/146,203, attorney docket no. 25791.25, filed on 7/29/1999; (12) U.S. provisional application no. 60/143,039, attorney docket no. 25791.26, filed on 7/9/1999; (13) U.S. provisional patent application serial no. 60/162,671, attorney docket no. 25791.27, filed on 11/1/1999; (14) U.S. provisional application no. 60/159,039, attorney docket no. 25791.36, filed on 10/12,1999; (15) U.S. provisional patent application no. 60/159,033, attorney docket no. 25791.37, filed on 10/12/1999; and (16) U.S. provisional patent application no. 60/165,228, attorney docket no. 25791.39, filed on 11/12/1999, the disclosures of which are incorporated herein by reference.

The expansion cone 1440 is coupled to the first support member 1420 and the third support member 1445. The expansion cone 1440 is preferably adapted to radially expand the expandable tubular member 1435 when the expansion cone 1440 is axially displaced relative to the expandable tubular member 1435.

In a preferred embodiment, the expansion cone 1440 is provided substantially as disclosed in one or more of the following: (1) U.S. utility patent application serial no. 09/454,139, attorney docket no. 25791.3.02, filed on 12/3/1999, which claimed the benefit of the filing date of U.S. provisional patent application no. 60/111,293, attorney docket no. 25791.3, filed on 12/7/1998; (2) U.S. utility patent application serial no. 09/510,913, attorney docket no. 25791.7.02, filed on 2/23/2000, which claimed the benefit of the filing date of U.S. provisional application no. 60/121,702, filed on 2/25/1999; (3) U.S. utility patent application serial no. 09/502,350, attorney docket no. 25791.8.02, filed on 2/10/2000, which claimed the benefit of the filing date of U.S. provisional application no. 60/119,611, attorney docket no. 25791.8; (4) U.S. utility patent application serial no. 09/440,338, attorney docket no. 25791.9.02, filed on 11/15/1999, which claimed the benefit of the filing date of U.S. provisional application no. 60/108,558, attorney docket no. 25791.9, filed on 11/16.1998; (5) U.S. provisional patent application no. 60/183,546, filed on 2/18/2000; (6) U.S. utility patent application no. 09/523,460, attorney docket

no. 25791.11.02, filed on 3/10/2000, which claimed the benefit of the filing date of U.S. provisional application no. 60/124,042, filed on 3/11/1999; (7) U.S. utility patent application no. 09/512,895, attorney docket no. 25791.12.02, filed on 2/24/2000, which claimed the benefit of the filing dates of U.S. provisional application no. 5 60/121,841, attorney docket no. 25791.12, filed on 2/26/1999 and U.S. provisional application no. 60/154,047, attorney docket no. 25791.29, filed on 9/16/1999; (8) U.S. utility application no. 09/511,941, attorney docket no. 25791.16.02, filed on 2/24/2000, which claimed the benefit of the filing date of U.S. provisional serial no. 60/121,907, attorney docket no. 25791.16, filed on 2/26/1999; (9) U.S. utility patent 10 application no. 09/588,946, attorney docket no. 25791.17.02, filed on June 7, 2000, which claimed the benefit of the filing date of U.S. provisional patent application serial no. 60/137,998, attorney docket no. 25791.17, filed on 6/7/1999; (10) U.S. utility patent application no. 09/559,122, attorney docket no. 25791.23.02, filed on 4/26/2000, which claimed the benefit of the filing date of U.S. provisional application 15 no. 60/131,106, attorney docket no. 25791.23, filed on 4/26/1999; (11) U.S. provisional application no. 60/146,203, attorney docket no. 25791.25, filed on 7/29/1999; (12) U.S. provisional application no. 60/143,039, attorney docket no. 25791.26, filed on 7/9/1999; (13) U.S. provisional patent application serial no. 60/162,671, attorney docket no. 25791.27, filed on 11/1/1999; (14) U.S. provisional 20 application no. 60/159,039, attorney docket no. 25791.36, filed on 10/12,1999; (15) U.S. provisional patent application no. 60/159,033, attorney docket no. 25791.37, filed on 10/12/1999; and (16) U.S. provisional patent application no. 60/165,228, attorney docket no. 25791.39, filed on 11/12/1999, the disclosures of which are incorporated herein by reference.

25           The third support member 1445 is preferably coupled to the expansion cone 1440 and the packer 1450. The third support member 1445 is preferably adapted to convey pressurized fluidic materials and/or electrical current and/or communication signals from a surface location to the packer 1450. The third support member 1445 may, for example, be conventional commercially available slick wire, braided wire, 30 coiled tubing, or drilling stock material.

          The packer 1450 is coupled to the third support member 1445. The packer 1450 is further preferably adapted to controllably coupled to the wellbore casing 1400. The packer 1450 may be any number of conventional commercially available packer devices. In an alternative embodiment, a bladder, slipped cage assembly or 35 hydraulic slips may be substituted for the packer 1450.

As illustrated in FIG. 14a, the apparatus 1415 is preferably positioned within the wellbore casing 1400 with the bottom of the expandable tubular member 1435 and the top of the expansion cone 1440 positioned proximate the opening 1410.

As illustrated in FIG. 14b, in a preferred embodiment, the packer 1450 is then anchored to the wellbore casing 1400. In this manner, the expansion cone 1440 is maintained in a substantially stationary position.

As illustrated in FIG. 14c, in a preferred embodiment, the expandable tubular member 1435 is then lowered towards the stationary expansion cone 1440. In a preferred embodiment, as illustrated in FIG. 14d, the lower end of the expandable tubular member 1435 impacts the expansion cone 1440 and is radially expanded into contact with the wellbore casing 1400. In a preferred embodiment, the lower end of the expandable tubular member 1435 includes one or more engagement devices for engaging the wellbore casing 1400 in order to optimally couple the end of the expandable tubular member 1435 to the wellbore casing 1400.

In an alternative embodiment, a compressible cement and/or epoxy is then injected into the annular space between the unexpanded portion of the tubular member 1435 and the wellbore casing 1400. The compressible cement and/or epoxy is then permitted to at least partially cure prior to the initiation of the radial expansion process. In this manner, an annular structural support and fluidic seal is provided around the tubular member 1435.

As illustrated in FIG. 14e, in a preferred embodiment, the packer 1450 is decoupled from the wellbore casing 1400.

As illustrated in FIG. 14f, in a preferred embodiment, the expansion cone 1440 is then axially displaced by applying an axial force to the first support member 1420. In a preferred embodiment, the axial displacement of the expansion cone 1440 radially expands the expandable tubular member 1435 into intimate contact with the walls of the wellbore casing 1400. In a preferred embodiment, prior to the initiation of the axial displacement of the expansion cone 1440, the coupling 1430 is decoupled from the expandable tubular member 1430.

As illustrated in FIG. 14g, in a preferred embodiment, after the expandable tubular member 1435 has been completely radially expanded by the axial displacement of the expansion cone 1440, the opening 1410 in the wellbore casing 1400 is sealed off by the radially expanded tubular member 1435. In this manner, repairs to the wellbore casing 1400 are optimally provided. More generally, the

apparatus 1415 is used to repair or form wellbore casings, pipelines, and structural supports.

Referring to FIGS. 15a to 15d, an alternative embodiment of an apparatus for coupling an expandable tubular member to a preexisting structure will now be described. Referring to Fig. 15a, a wellbore casing 1500 is positioned within a  
5 subterranean formation 1505. The wellbore casing 1500 may be positioned in any orientation from the vertical direction to the horizontal direction. The wellbore casing 1500 further includes one or more openings 1510 that may have been the result of unintentional damage to the wellbore casing 1500, or due to a prior perforation or  
10 fracturing operation performed upon the surrounding subterranean formation 1505. As will be recognized by persons having ordinary skill in the art, the openings 1510 can adversely affect the subsequent operation and use of the wellbore casing 1500 unless they are sealed off.

In a preferred embodiment, an apparatus 1515 is utilized to seal off the  
15 openings 1510 in the wellbore casing 1500. More generally, the apparatus 1515 is preferably utilized to form or repair wellbore casings, pipelines, or structural supports.

The apparatus 1515 preferably includes a support member 1520, an expandable tubular member 1525, an expansion cone 1530, a coupling 1535, a  
20 resilient anchor 1540, and one or more seals 1545.

The support member 1520 is preferably adapted to be coupled to a surface location. The support member 1520 is further coupled to the expansion cone 1530. The support member 1520 is preferably adapted to convey pressurized fluidic materials and/or electrical current and/or communication signals from a surface  
25 location to the resilient anchor 1540. The support member 1520 may, for example, be conventional commercially available slick wire, braided wire, coiled tubing, or drilling stock material.

The expandable tubular member 1525 is removably coupled to the expansion cone 1530. In a preferred embodiment, the expandable tubular member  
30 1525 includes one or more engagement devices that are adapted to couple with and penetrate the wellbore casing 1500. In this manner, the expandable tubular member 1525 is optimally coupled to the wellbore casing 1500. In a preferred embodiment, the engagement devices include teeth for biting into the surface of the wellbore casing 1500. In a preferred embodiment, the expandable tubular member  
35 1525 further includes one or more sealing members 1545 on the outside surface of

the expandable tubular member 1525 in order to optimally seal the interface between the expandable tubular member 1525 and the wellbore casing 1500.

In a preferred embodiment, the expandable tubular member 1525 includes a lower section 1550, an intermediate section 1555, and an upper section 1560. In a preferred embodiment, the wall thicknesses of the lower and intermediate sections, 1550 and 1555, are less than the wall thickness of the upper section 1560 in order to optimally facilitate the radial expansion of the expandable tubular member 1525. In a preferred embodiment, the sealing members 1545 are provided on the outside surface of the upper section 1560 of the expandable tubular member 1525. In a preferred embodiment, the resilient anchor 1540 is coupled to the lower section 1550 of the expandable tubular member 1525 in order to optimally anchor the expandable tubular member 1525 to the wellbore casing 1500.

In a preferred embodiment, the expandable tubular member 1525 is further provided substantially as disclosed in one or more of the following: (1) U.S. utility patent application serial no. 09/454,139, attorney docket no. 25791.3.02, filed on 12/3/1999, which claimed the benefit of the filing date of U.S. provisional patent application no. 60/111,293, attorney docket no. 25791.3, filed on 12/7/1998; (2) U.S. utility patent application serial no. 09/510,913, attorney docket no. 25791.7.02, filed on 2/23/2000, which claimed the benefit of the filing date of U.S. provisional application no. 60/121,702, filed on 2/25/1999; (3) U.S. utility patent application serial no. 09/502,350, attorney docket no. 25791.8.02, filed on 2/10/2000, which claimed the benefit of the filing date of U.S. provisional application no. 60/119,611, attorney docket no. 25791.8; (4) U.S. utility patent application serial no. 09/440,338, attorney docket no. 25791.9.02, filed on 11/15/1999, which claimed the benefit of the filing date of U.S. provisional application no. 60/108,558, attorney docket no. 25791.9, filed on 11/16.1998; (5) U.S. provisional patent application no. 60/183,546, filed on 2/18/2000; (6) U.S. utility patent application no. 09/523,460, attorney docket no. 25791.11.02, filed on 3/10/2000, which claimed the benefit of the filing date of U.S. provisional application no. 60/124,042, filed on 3/11/1999; (7) U.S. utility patent application no. 09/512,895, attorney docket no. 25791.12.02, filed on 2/24/2000, which claimed the benefit of the filing dates of U.S. provisional application no. 60/121,841, attorney docket no. 25791.12, filed on 2/26/1999 and U.S. provisional application no. 60/154,047, attorney docket no. 25791.29, filed on 9/16/1999; (8) U.S. utility application no. 09/511,941, attorney docket no. 25791.16.02, filed on 2/24/2000, which claimed the benefit of the filing date of U.S. provisional serial no.



60/121,907, attorney docket no. 25791.16, filed on 2/26/1999; (9) U.S. utility patent application no. 09/588,946, attorney docket no. 25791.17.02, filed on June 7, 2000, which claimed the benefit of the filing date of U.S. provisional patent application serial no. 60/137,998, attorney docket no. 25791.17, filed on 6/7/1999; (10) U.S. utility patent application no. 09/559,122, attorney docket no. 25791.23.02, filed on 4/26/2000, which claimed the benefit of the filing date of U.S. provisional application no. 60/131,106, attorney docket no. 25791.23, filed on 4/26/1999; (11) U.S. provisional application no. 60/146,203, attorney docket no. 25791.25, filed on 7/29/1999; (12) U.S. provisional application no. 60/143,039, attorney docket no. 25791.26, filed on 7/9/1999; (13) U.S. provisional patent application serial no. 60/162,671, attorney docket no. 25791.27, filed on 11/1/1999; (14) U.S. provisional application no. 60/159,039, attorney docket no. 25791.36, filed on 10/12,1999; (15) U.S. provisional patent application no. 60/159,033, attorney docket no. 25791.37, filed on 10/12/1999; and (16) U.S. provisional patent application no. 60/165,228, attorney docket no. 25791.39, filed on 11/12/1999, the disclosures of which are incorporated herein by reference.

The expansion cone 1530 is coupled to the support member 1520 and the coupling 1535. The expansion cone 1530 is preferably adapted to radially expand the expandable tubular member 1525 when the expansion cone 1530 is axially displaced relative to the expandable tubular member 1525. The expansion cone 1530 may be any number of conventional commercially available expansion cones.

In a preferred embodiment, the expansion cone 1530 is provided substantially as disclosed in one or more of the following: (1) U.S. utility patent application serial no. 09/454,139, attorney docket no. 25791.3.02, filed on 12/3/1999, which claimed the benefit of the filing date of U.S. provisional patent application no. 60/111,293, attorney docket no. 25791.3, filed on 12/7/1998; (2) U.S. utility patent application serial no. 09/510,913, attorney docket no. 25791.7.02, filed on 2/23/2000, which claimed the benefit of the filing date of U.S. provisional application no. 60/121,702, filed on 2/25/1999; (3) U.S. utility patent application serial no. 09/502,350, attorney docket no. 25791.8.02, filed on 2/10/2000, which claimed the benefit of the filing date of U.S. provisional application no. 60/119,611, attorney docket no. 25791.8; (4) U.S. utility patent application serial no. 09/440,338, attorney docket no. 25791.9.02, filed on 11/15/1999, which claimed the benefit of the filing date of U.S. provisional application no. 60/108,558, attorney docket no. 25791.9, filed on 11/16.1998; (5) U.S. provisional patent application no. 60/183,546,

filed on 2/18/2000; (6) U.S. utility patent application no. 09/523,460, attorney docket no. 25791.11.02, filed on 3/10/2000, which claimed the benefit of the filing date of U.S. provisional application no. 60/124,042, filed on 3/11/1999; (7) U.S. utility patent application no. 09/512,895, attorney docket no. 25791.12.02, filed on 2/24/2000, 5 which claimed the benefit of the filing dates of U.S. provisional application no. 60/121,841, attorney docket no. 25791.12, filed on 2/26/1999 and U.S. provisional application no. 60/154,047, attorney docket no. 25791.29, filed on 9/16/1999; (8) U.S. utility application no. 09/511,941, attorney docket no. 25791.16.02, filed on 2/24/2000, which claimed the benefit of the filing date of U.S. provisional serial no. 10 60/121,907, attorney docket no. 25791.16, filed on 2/26/1999; (9) U.S. utility patent application no. 09/588,946, attorney docket no. 25791.17.02, filed on June 7, 2000, which claimed the benefit of the filing date of U.S. provisional patent application serial no. 60/137,998, attorney docket no. 25791.17, filed on 6/7/1999; (10) U.S. utility patent application no. 09/559,122, attorney docket no. 25791.23.02, filed on 15 4/26/2000, which claimed the benefit of the filing date of U.S. provisional application no. 60/131,106, attorney docket no. 25791.23, filed on 4/26/1999; (11) U.S. provisional application no. 60/146,203, attorney docket no. 25791.25, filed on 7/29/1999; (12) U.S. provisional application no. 60/143,039, attorney docket no. 25791.26, filed on 7/9/1999; (13) U.S. provisional patent application serial no. 20 60/162,671, attorney docket no. 25791.27, filed on 11/1/1999; (14) U.S. provisional application no. 60/159,039, attorney docket no. 25791.36, filed on 10/12,1999; (15) U.S. provisional patent application no. 60/159,033, attorney docket no. 25791.37, filed on 10/12/1999; and (16) U.S. provisional patent application no. 60/165,228, attorney docket no. 25791.39, filed on 11/12/1999, the disclosures of which are 25 incorporated herein by reference.

The coupling 1535 is preferably coupled to the support member 1520, the expansion cone 1530 and the resilient anchor 1540. The coupling 1535 is preferably adapted to convey pressurized fluidic materials and/or electrical current and/or communication signals from a surface location to the resilient anchor 1535. 30 The coupling 1535 may, for example, be conventional commercially available slick wire, braided wire, coiled tubing, or drilling stock material. In a preferred embodiment, the coupling 1535 is decoupled from the resilient anchor 1540 upon initiating the axial displacement of the expansion cone 1530.

The resilient anchor 1540 is preferably coupled to the lower section 1550 of 35 the expandable tubular member 1525 and the coupling 1535. The resilient anchor

1540 is further preferably adapted to be controllably coupled to the wellbore casing 1500.

Referring to FIGS. 16a and 16b, in a preferred embodiment, the resilient anchor 1540 includes one or more coiled resilient members 1600 and corresponding  
5 releasable coupling devices 1605. In a preferred embodiment, the resilient anchor 1540 is maintained in a compressed elastic position that is controllably released thereby causing the resilient anchor 1540 to expand in size thereby releasing the elastic energy stored within the resilient anchor 1540. As illustrated in FIG. 16b, in a preferred embodiment, when the coupling device 1605 is released, the coiled  
10 resilient member 1600 at least partially uncoils in the outward radial direction. In a preferred embodiment, at least a portion of the coiled member 1600 is coupled to the lower section 1550 of the expandable tubular member 1525. In a preferred embodiment, the uncoiled member 1600 thereby couples the lower section 1550 of the expandable tubular member 1525 to the wellbore casing 1500.

15 The coiled member 1600 may be fabricated from any number of conventional commercially available resilient materials. In a preferred embodiment, the coiled member 1600 is fabricated from a resilient material such as, for example, spring steel. In a preferred embodiment, the coiled member 1600 is fabricated from memory metals in order to optimally provide control of shapes and stresses.

20 In a preferred embodiment, the releasable coupling device 1605 maintains the coiled member 1600 in a coiled position until the device 1605 is released. The releasable coupling device 1605 may be any number of conventional commercially available releasable coupling devices such as, for example, an explosive bolt.

The resilient anchor 1540 may be positioned in any desired orientation. In a  
25 preferred embodiment, the resilient anchor 1540 is positioned to apply the maximum normal force to the walls of the wellbore casing 1500 after releasing the resilient anchor 1540.

In an alternate embodiment, as illustrated in FIGS. 17a and 17b, the resilient anchor 1540 includes a tubular member 1700, one or more resilient anchoring  
30 members 1705, one or more corresponding rigid attachments 1710, and one or more corresponding releasable attachments 1715. In a preferred embodiment, the resilient anchoring members 1705 are maintained in compressed elastic condition by the corresponding rigid and releasable attachments, 1710 and 1715. In a preferred embodiment, when the corresponding releasable attachment 1715 is

released, the corresponding resilient anchoring member 1705 expands, releasing the stored elastic energy, away from the tubular member 1700.

As illustrated in FIG. 17a, one end of each resilient anchoring member 1705 is rigidly attached to the outside surface of the tubular member 1700 by a corresponding rigid attachment 1710. The other end of each resilient anchoring member 1705 is removably attached to the outside surface of the tubular member 1700 by a corresponding releasable attachment 1715. As illustrated in FIG. 17b, in a preferred embodiment, releasing the releasable attachment 1715 permits the resilient energy stored in the resilient anchoring member 1705 to be released thereby causing the resilient anchoring member 1705 to swing radially outward from the tubular member 1700.

The tubular member 1700 may be fabricated from any number of conventional materials.

The resilient anchoring members 1705 may be fabricated from any number of resilient materials. In a preferred embodiment, the resilient anchoring members 1705 are fabricated from memory metal in order to optimally provide control of shapes and stresses.

The rigid attachments 1710 may be fabricated from any number of conventional commercially available materials. In a preferred embodiment, the rigid attachments 1710 are fabricated from 4140 steel in order to optimally provide high strength.

The releasable attachments 1715 may be fabricated from any number of conventional commercially available devices such as, for example, explosive bolts.

In another alternative embodiment, as illustrated in FIGS. 18a and 18b, the resilient anchor 1540 includes a tubular member 1800, one or more anchoring devices 1805, one or more resilient members 1810, and one or more release devices 1815. In a preferred embodiment, the anchoring devices 1805 and resilient members 1810 are maintained in a compressed elastic position by the release devices 1815. As illustrated in FIG. 18b, in a preferred embodiment, when the release devices 1815 are removed, the anchoring devices 1805 and resilient members 1810 are permitted to expand outwardly in the radial direction.

The tubular member 1800 preferably includes one or more openings 1820 for containing the release devices 1815 and for permitting the anchoring devices 1805 to pass through. The tubular member 1800 may be fabricated from any number of conventional commercially available materials. In a preferred

embodiment, the tubular member 1800 is fabricated from 4140 steel in order to optimally provide high strength.

The anchoring devices 1805 are housed within the tubular member 1800. The anchoring devices 1805 are preferably adapted to at least partially extend  
5 through the corresponding openings 1820 in the tubular member 1800. The anchoring devices 1805 are preferably adapted to couple to, and at least partially penetrate, the surface of the wellbore 1500. The anchoring devices 1805 may be fabricated from any number of durable hard materials such as, for example, tungsten carbide, machine tool steel, or hard faced steel. In a preferred  
10 embodiment, the anchoring devices 1805 are fabricated from machine tool steel in order to optimally provide high strength, hardness, and fracture toughness.

The resilient members 1810 are coupled to the inside surface of the tubular member 1800. The resilient members 1810 are preferably adapted to apply a radial force upon the corresponding anchoring devices 1805. In a preferred embodiment,  
15 when the release devices 1815 release the anchoring devices 1805, the resilient members 1810 are preferably adapted to force the anchoring devices at least partially through the corresponding openings 1820 into contact with, to at least partially penetrate, the wellbore casing 1500.

The release devices 1815 are positioned within and coupled to the openings  
20 1820 in the tubular member 1800. The release devices 1815 are preferably adapted to hold the corresponding anchoring devices 1805 within the tubular member 1800 until released by a control signal provided from a surface, or other, location. The release devices 1815 may be any number of conventional commercially available release devices. In a preferred embodiment, the release devices 1815 are pressure  
25 activated in order to optimally provide ease of operation.

As illustrated in FIG. 15a, the apparatus 1515 is preferably positioned within the wellbore casing 1500 with the expandable tubular member 1525 positioned in opposing relation to the opening 1510.

As illustrated in FIG. 15b, in a preferred embodiment, the resilient anchor  
30 1540 is then anchored to the wellbore casing 1500. In this manner, the lower section 1550 of the expandable tubular member 1525 is anchored to the wellbore casing 1500. In a preferred embodiment, the resilient anchor 1540 is anchored by a control and/or electrical power signal transmitted from a surface location.

In an alternative embodiment, a compressible cement and/or epoxy is then  
35 injected into the annular space between the unexpanded portion of the tubular

member 1525 and the wellbore casing 1500. The compressible cement and/or epoxy is then permitted to at least partially cure prior to the initiation of the radial expansion process. In this manner, an annular structural support and fluidic seal is provided around the tubular member 1525.

5           As illustrated in FIG. 15c, in a preferred embodiment, the expansion cone 1530 is then axially displaced by applying an axial force to the support member 1520. In a preferred embodiment, the axial displacement of the expansion cone 1530 radially expands the expandable tubular member 1525 into intimate contact with the walls of the wellbore casing 1500.

10           As illustrated in FIG. 15d, in a preferred embodiment, after the expandable tubular member 1525 has been completely radially expanded by the axial displacement of the expansion cone 1530, the opening 1510 in the wellbore casing 1500 is sealed off by the radially expanded tubular member 1525. In this manner, repairs to the wellbore casing 1500 are optimally provided. More generally, the apparatus 1515 is used to repair or form wellbore casings, pipelines, and structural supports.

          Referring to FIGS. 19a, 19b and 19c, an alternative embodiment of an expandable tubular member 1900 for use in the apparatus 1515 will now be described. In a preferred embodiment, the expandable tubular member 1900 includes a tubular body 1905, one or more resilient panels 1910, one or more corresponding engagement members 1915, and a release member 1920. In a preferred embodiment, the resilient panels 1910 are adapted to expand in the radial direction after being released by the release member 1920. In this manner, the expandable tubular member 1900 is anchored to a preexisting structure such as, for example, a wellbore casing, an open hole wellbore section, a pipeline, or a structural support.

          The tubular member 1905 is coupled to the resilient panels 1910. The tubular member 1905 may be any number of conventional commercially available expandable tubular members. In a preferred embodiment, the tubular member 1905 is an expandable casing in order to optimally provide high strength.

          The resilient panels 1910 are coupled to the tubular member 1905. The resilient panels 1910 are further releasably coupled to the release member 1920. The resilient panels 1910 are preferably adapted to house the expansion cone 1530. The resilient panels 1910 are preferably adapted to extend to the position 1925 upon being released by the release member 1920. In a preferred

-----  
embodiment, the resilient panels 1910 are coupled to the tubular member 1905 by welding in order to optimally provide high strength. The resilient panels 1910 may be fabricated from any number of conventional commercially available resilient materials. In a preferred embodiment, the resilient panels 1910 are fabricated from  
5 spring steel in order to optimally store elastic radially directed energy.

The engagement members 1915 are coupled to corresponding resilient panels. The engagement members 1915 are preferably adapted to engage, and at least partially penetrate, the wellbore casing 1500, or other preexisting structure.

The release member 1920 is releasably coupled to the resilient panels 1910.

10 The release member 1920 is preferably adapted to controllably release the resilient panels 1910 from their initial strained positions in order to permit the resilient panels 1910 to expand to their expanded positions 1925. In a preferred embodiment, the release member 1920 is releasably coupled to the coupling 1535. In this manner, electrical and/or control and/or hydraulic signals are communicated to and/or from  
15 the release member 1920. The release member 1920 may be any number of conventional commercially available release devices.

Referring to FIGS. 20a to 20d, an alternative embodiment of an apparatus and method for coupling an expandable tubular member to a preexisting structure will now be described. Referring to Fig. 20a, a wellbore casing 2000 is positioned  
20 within a subterranean formation 2005. The wellbore casing 2000 may be positioned in any orientation from the vertical direction to the horizontal direction. The wellbore casing 2000 further includes one or more openings 2010 that may have been the result of unintentional damage to the wellbore casing 2000, or due to a prior perforation or fracturing operation performed upon the surrounding subterranean  
25 formation 2005. As will be recognized by persons having ordinary skill in the art, the openings 2010 can adversely affect the subsequent operation and use of the wellbore casing 2000 unless they are sealed off.

In a preferred embodiment, an apparatus 2015 is utilized to seal off the openings 2010 in the wellbore casing 2000. More generally, the apparatus 2015 is  
30 preferably utilized to form or repair wellbore casings, pipelines, or structural supports.

The apparatus 2015 preferably includes a support member 2020, an expandable tubular member 2025, an expansion cone 2030, a coupling 2035, a resilient anchor 2040, and one or more seals 2045.

The support member 2020 is preferably adapted to be coupled to a surface location. The support member 2020 is further coupled to the expansion cone 2030. The support member 2020 is preferably adapted to convey pressurized fluidic materials and/or electrical current and/or communication signals from a surface  
5 location to the anchor 2040. The support member 2020 may, for example, be conventional commercially available slick wire, braided wire, coiled tubing, or drilling stock material.

The expandable tubular member 2025 is removably coupled to the expansion cone 2030. In a preferred embodiment, the expandable tubular member  
10 2025 includes one or more engagement devices that are adapted to couple with and penetrate the wellbore casing 2000. In this manner, the expandable tubular member 2025 is optimally coupled to the wellbore casing 2000. In a preferred embodiment, the engagement devices include teeth for biting into the surface of the wellbore casing 2000. In a preferred embodiment, the expandable tubular member  
15 2025 further includes one or more sealing members 2045 on the outside surface of the expandable tubular member 2025 in order to optimally seal the interface between the expandable tubular member 2025 and the wellbore casing 2000.

In a preferred embodiment, the expandable tubular member 2025 includes a lower section 2050, an intermediate section 2055, and an upper section 2060. In a  
20 preferred embodiment, the wall thicknesses of the lower and intermediate sections, 2050 and 2055, are less than the wall thickness of the upper section 2060 in order to optimally facilitate the radial expansion of the expandable tubular member 2025. In a preferred embodiment, the sealing members 2045 are provided on the outside surface of the upper section 2060 of the expandable tubular member 2025. In a  
25 preferred embodiment, the resilient anchor 2040 is coupled to the lower section 2050 of the expandable tubular member 2025 in order to optimally anchor the expandable tubular member 2025 to the wellbore casing 2000.

In a preferred embodiment, the expandable tubular member 2025 is further provided substantially as disclosed in one or more of the following: (1) U.S. utility  
30 patent application serial no. 09/454,139, attorney docket no. 25791.3.02, filed on 12/3/1999, which claimed the benefit of the filing date of U.S. provisional patent application no. 60/111,293, attorney docket no. 25791.3, filed on 12/7/1998; (2) U.S. utility patent application serial no. 09/510,913, attorney docket no. 25791.7.02, filed on 2/23/2000, which claimed the benefit of the filing date of U.S. provisional  
35 application no. 60/121,702, filed on 2/25/1999; (3) U.S. utility patent application



serial no. 09/502,350, attorney docket no. 25791.8.02, filed on 2/10/2000, which claimed the benefit of the filing date of U.S. provisional application no. 60/119,611, attorney docket no. 25791.8; (4) U.S. utility patent application serial no. 09/440,338, attorney docket no. 25791.9.02, filed on 11/15/1999, which claimed the benefit of the filing date of U.S. provisional application no. 60/108,558, attorney docket no. 25791.9, filed on 11/16.1998; (5) U.S. provisional patent application no. 60/183,546, filed on 2/18/2000; (6) U.S. utility patent application no. 09/523,460, attorney docket no. 25791.11.02, filed on 3/10/2000, which claimed the benefit of the filing date of U.S. provisional application no. 60/124,042, filed on 3/11/1999; (7) U.S. utility patent application no. 09/512,895, attorney docket no. 25791.12.02, filed on 2/24/2000, which claimed the benefit of the filing dates of U.S. provisional application no. 60/121,841, attorney docket no. 25791.12, filed on 2/26/1999 and U.S. provisional application no. 60/154,047, attorney docket no. 25791.29, filed on 9/16/1999; (8) U.S. utility application no. 09/511,941, attorney docket no. 25791.16.02, filed on 2/24/2000, which claimed the benefit of the filing date of U.S. provisional serial no. 60/121,907, attorney docket no. 25791.16, filed on 2/26/1999; (9) U.S. utility patent application no. 09/588,946, attorney docket no. 25791.17.02, filed on June 7, 2000, which claimed the benefit of the filing date of U.S. provisional patent application serial no. 60/137,998, attorney docket no. 25791.17, filed on 6/7/1999; (10) U.S. utility patent application no. 09/559,122, attorney docket no. 25791.23.02, filed on 4/26/2000, which claimed the benefit of the filing date of U.S. provisional application no. 60/131,106, attorney docket no. 25791.23, filed on 4/26/1999; (11) U.S. provisional application no. 60/146,203, attorney docket no. 25791.25, filed on 7/29/1999; (12) U.S. provisional application no. 60/143,039, attorney docket no. 25791.26, filed on 7/9/1999; (13) U.S. provisional patent application serial no. 60/162,671, attorney docket no. 25791.27, filed on 11/1/1999; (14) U.S. provisional application no. 60/159,039, attorney docket no. 25791.36, filed on 10/12,1999; (15) U.S. provisional patent application no. 60/159,033, attorney docket no. 25791.37, filed on 10/12/1999; and (16) U.S. provisional patent application no. 60/165,228, attorney docket no. 25791.39, filed on 11/12/1999, the disclosures of which are incorporated herein by reference.

The expansion cone 2030 is preferably coupled to the support member 2020 and the coupling 2035. The expansion cone 2030 is preferably adapted to radially expand the expandable tubular member 2025 when the expansion cone 2030 is axially displaced relative to the expandable tubular member 2025.

In a preferred embodiment, the expansion cone 2030 is provided substantially as disclosed in one or more of the following: (1) U.S. utility patent application serial no. 09/454,139, attorney docket no. 25791.3.02, filed on 12/3/1999, which claimed the benefit of the filing date of U.S. provisional patent application no. 60/111,293, attorney docket no. 25791.3, filed on 12/7/1998; (2) U.S. utility patent application serial no. 09/510,913, attorney docket no. 25791.7.02, filed on 2/23/2000, which claimed the benefit of the filing date of U.S. provisional application no. 60/121,702, filed on 2/25/1999; (3) U.S. utility patent application serial no. 09/502,350, attorney docket no. 25791.8.02, filed on 2/10/2000, which claimed the benefit of the filing date of U.S. provisional application no. 60/119,611, attorney docket no. 25791.8; (4) U.S. utility patent application serial no. 09/440,338, attorney docket no. 25791.9.02, filed on 11/15/1999, which claimed the benefit of the filing date of U.S. provisional application no. 60/108,558, attorney docket no. 25791.9, filed on 11/16.1998; (5) U.S. provisional patent application no. 60/183,546, filed on 2/18/2000; (6) U.S. utility patent application no. 09/523,460, attorney docket no. 25791.11.02, filed on 3/10/2000, which claimed the benefit of the filing date of U.S. provisional application no. 60/124,042, filed on 3/11/1999; (7) U.S. utility patent application no. 09/512,895, attorney docket no. 25791.12.02, filed on 2/24/2000, which claimed the benefit of the filing dates of U.S. provisional application no. 60/121,841, attorney docket no. 25791.12, filed on 2/26/1999 and U.S. provisional application no. 60/154,047, attorney docket no. 25791.29, filed on 9/16/1999; (8) U.S. utility application no. 09/511,941, attorney docket no. 25791.16.02, filed on 2/24/2000, which claimed the benefit of the filing date of U.S. provisional serial no. 60/121,907, attorney docket no. 25791.16, filed on 2/26/1999; (9) U.S. utility patent application no. 09/588,946, attorney docket no. 25791.17.02, filed on June 7, 2000, which claimed the benefit of the filing date of U.S. provisional patent application serial no. 60/137,998, attorney docket no. 25791.17, filed on 6/7/1999; (10) U.S. utility patent application no. 09/559,122, attorney docket no. 25791.23.02, filed on 4/26/2000, which claimed the benefit of the filing date of U.S. provisional application no. 60/131,106, attorney docket no. 25791.23, filed on 4/26/1999; (11) U.S. provisional application no. 60/146,203, attorney docket no. 25791.25, filed on 7/29/1999; (12) U.S. provisional application no. 60/143,039, attorney docket no. 25791.26, filed on 7/9/1999; (13) U.S. provisional patent application serial no. 60/162,671, attorney docket no. 25791.27, filed on 11/1/1999; (14) U.S. provisional application no. 60/159,039, attorney docket no. 25791.36, filed on 10/12,1999; (15)

U.S. provisional patent application no. 60/159,033, attorney docket no. 25791.37, filed on 10/12/1999; and (16) U.S. provisional patent application no. 60/165,228, attorney docket no. 25791.39, filed on 11/12/1999, the disclosures of which are incorporated herein by reference.

5           The coupling 2035 is preferably coupled to the support member 2020, the expansion cone 2030, and the anchor 2040. The coupling 2035 is preferably adapted to convey pressurized fluidic materials and/or electrical current and/or communication signals from a surface location to the anchor 2035. The coupling 2035 may, for example, be conventional commercially available slick wire, braided  
10 wire, coiled tubing, or drilling stock material. In a preferred embodiment, the coupling 2035 is decoupled from the anchor 2040 upon initiating the axial displacement of the expansion cone 2030.

          The anchor 2040 is preferably coupled to the lower section 2050 of the expandable tubular member 2025 and the coupling 2035. The anchor 2040 is  
15 further preferably adapted to be controllably coupled to the wellbore casing 2000.

          Referring to FIGS. 21a and 21b, in a preferred embodiment, the anchor 2040 includes a housing 2100, one or more spikes 2105, and one or more corresponding actuators 2110. In a preferred embodiment, the spikes 2105 are outwardly extended by the corresponding actuators 2110. In an alternative embodiment, the  
20 spikes 2105 are outwardly actuated by displacing the apparatus 2015 upwardly. In another alternative embodiment, the spikes 2105 are outwardly extended by placing a quantity of fluidic material onto the spikes 2105.

          The housing 2100 is coupled to the lower section 2050 of the expandable tubular member 2025, the spikes 2105, and the actuators 2110. The housing 2100  
25 is further preferably coupled to the coupling 2035. In a preferred embodiment, the housing 2100 is adapted to convey electrical, communication, and/or hydraulic signals from the coupling 2035 to the actuators 2110.

          The spikes 2105 are preferably movably coupled to the housing 2100 and the corresponding actuators 2110. The spikes 2105 are preferably adapted to pivot  
30 relative to the housing 2100. The spikes 2105 are further preferably adapted to extend outwardly in a radial direction to engage, and at least partially penetrate, the wellbore casing 2000, or other preexisting structure such as, for example, the wellbore. Each of the spikes 2105 further preferably include a concave upwardly facing surface 2115. In a preferred embodiment, the placement of a quantity of  
35 fluidic material such as, for example, a barite plug or a flex plug, onto the surfaces

2115 causes the spikes 2105 to pivot outwardly away from the housing 2100 to engage the wellbore casing 2000, or other preexisting structure such as, for example, the wellbore. Alternatively, the upward displacement of the apparatus 2015 causes the spikes 2105 to pivot outwardly away from the housing 2100 to engage the wellbore casing 2000, or other preexisting structure such as, for example, the wellbore.

The actuators 2110 are preferably coupled to the housing 2100 and the corresponding spikes 2105. The actuators 2110 are preferably adapted to apply a force to the corresponding spikes 2105 sufficient to pivot the corresponding spikes 2105 outwardly and away from the housing 2100. The actuators 2110 may be any number of conventional commercially available actuators such as, for example, a spring, an electric or hydraulic motor, a hydraulic piston/cylinder. In a preferred embodiment, the actuators 2110 are hydraulic pistons in order to optimally provide ease of operation. In an alternative embodiment, the actuators 2110 are omitted and the spikes are pivotally coupled to the housing 2100.

Referring to FIGS. 22a, 22b, and 22c, in an alternative embodiment, the anchor 2040 includes the housing 2100, one or more petal baskets 2205, and one or more corresponding actuators 2110. In a preferred embodiment, the petal baskets 2205 are outwardly extended by the corresponding actuators 2110. In an alternative embodiment, the petal baskets 2205 are outwardly actuated by displacing the apparatus 2015 upwardly. In another alternative embodiment, the petal baskets 2205 are outwardly extended by placing a quantity of fluidic material onto the petal baskets 2205.

The housing 2100 is coupled to the lower section 2050 of the expandable tubular member 2025, the petal baskets 2205, and the actuators 2110.

The petal baskets 2205 are preferably movably coupled to the housing 2100 and the corresponding actuators 2110. The petal baskets 2205 are preferably adapted to pivot relative to the housing 2100. The petal baskets 2205 are further preferably adapted to extend outwardly in a radial direction to engage, and at least partially penetrate, the wellbore casing 2000, or other preexisting structure. As illustrated in FIG. 22c, each of the petal baskets 2205 further preferably include a concave upwardly facing surface 2215. In a preferred embodiment, the placement of a quantity of fluidic material such as, for example, a barite plug or a flex plug, onto the surfaces 2215 causes the petal baskets 2205 to pivot outwardly away from the housing 2100 to engage the wellbore casing 2000, or other preexisting structure.

Alternatively, the weight of the fluidic materials placed onto the petal baskets 2205 is sufficient to anchor the expandable tubular member 2025. Alternatively, the upward displacement of the apparatus 2015 causes the petal baskets 2205 to pivot outwardly away from the housing 2100 to engage the wellbore casing 2000, or other preexisting structure.

The actuators 2110 are preferably coupled to the housing 2100 and the corresponding petal baskets 2205. The actuators 2110 are preferably adapted to apply a force to the corresponding petal baskets 2205 sufficient to pivot the corresponding petal baskets 2205 outwardly and away from the housing 2100. In an alternative embodiment, the actuators 2110 are omitted and the petal baskets are pivotally coupled to the housing 2100.

In an alternative embodiment, the anchor 2040 includes one or more spikes 2105 and one or more petal baskets 2205.

As illustrated in FIG. 20a, the apparatus 2015 is preferably positioned within the wellbore casing 2000 with the expandable tubular member 2025 positioned in opposing relation to the opening 2010.

As illustrated in FIG. 20b, in a preferred embodiment, the anchor 2040 is then anchored to the wellbore casing 2000. In this manner, the lower section 2050 of the expandable tubular member 2025 is anchored to the wellbore casing 2000 or the wellbore casing. In a preferred embodiment, the anchor 2040 is anchored by a control and/or electrical power signal transmitted from a surface location to the actuators 2110 of the anchor 2040. In an alternative embodiment, the anchor 2040 is anchored to the wellbore casing 2000 by upwardly displacing the apparatus 2015. In an alternative embodiment, the anchor 2040 is anchored to the wellbore casing 2000 by placing a quantity of a fluidic material such, for example, a barite plug or a flex plug, onto the spikes 2105 or petal baskets 2205 of the anchor 2040. In an alternative embodiment, the anchor 2040 is omitted, and the apparatus 2015 is anchored by placing a quantity of a fluidic material such, for example, a barite plug or a flex plug, onto at least the lower and/or the intermediate sections, 2050 and 2055, of the expandable tubular member 2025.

In an alternative embodiment, a compressible cement and/or epoxy is then injected into the annular space between the unexpanded portion of the tubular member 2025 and the wellbore casing 2000. The compressible cement and/or epoxy is then permitted to at least partially cure prior to the initiation of the radial

expansion process. In this manner, an annular structural support and fluidic seal is provided around the tubular member 2025.

As illustrated in FIG. 20c, in a preferred embodiment, the expansion cone 2030 is then axially displaced by applying an axial force to the support member 2020. In a preferred embodiment, the axial displacement of the expansion cone 2030 radially expands the expandable tubular member 2025 into intimate contact with the walls of the wellbore casing 2000.

As illustrated in FIG. 20d, in a preferred embodiment, after the expandable tubular member 2025 has been completely radially expanded by the axial displacement of the expansion cone 2030, the opening 2010 in the wellbore casing 2000 is sealed off by the radially expanded tubular member 1435. In this manner, repairs to the wellbore casing 2000 are optimally provided. More generally, the apparatus 2015 is used to repair or form wellbore casings, pipelines, and structural supports.

Referring to FIGS. 23a to 23e, an alternative embodiment of an apparatus and method for coupling an expandable tubular member to a preexisting structure will now be described. Referring to Fig. 23a, a wellbore casing 2300 and an open hole wellbore section 2305 are positioned within a subterranean formation 2310. The wellbore casing 2300 and the open hole wellbore section 2305 may be positioned in any orientation from the vertical direction to the horizontal direction.

In a preferred embodiment, an apparatus 2320 is utilized to form a new section of wellbore casing within the open hole wellbore section 2305. More generally, the apparatus 2320 is preferably utilized to form or repair wellbore casings, pipelines, or structural supports.

The apparatus 2320 preferably includes a support member 2325, an expandable tubular member 2330, an expansion cone 2335, one or more upper sealing members 2340, and one or more sealing members 2345.

The support member 2325 is preferably adapted to be coupled to a surface location. The support member 2325 is further coupled to the expansion cone 2335. The support member 2325 may, for example, be conventional commercially available slick wire, braided wire, coiled tubing, or drilling stock material.

The expandable tubular member 2330 is removably coupled to the expansion cone 2335. In a preferred embodiment, the expandable tubular member 2025 further includes one or more upper and lower sealing members, 2340 and 2345, on the outside surface of the expandable tubular member 2330 in order to

optimally seal the interface between the expandable tubular member 2330 and the wellbore casing 2300 and the open hole wellbore section 2305.

In a preferred embodiment, the expandable tubular member 2025 further includes a lower section 2350, an intermediate section 2355, and an upper section  
5 2360. In a preferred embodiment, the wall thicknesses of the lower and intermediate sections, 2350 and 2355, are less than the wall thickness of the upper section 2360 in order to optimally facilitate the radial expansion of the expandable tubular member 2330. In a preferred embodiment, the lower section 2350 of the expandable tubular member 2330 includes one or more slots 2365 adapted to  
10 permit a fluidic sealing material to penetrate the lower section 2350.

In a preferred embodiment, the expandable tubular member 2330 is further provided substantially as disclosed in one or more of the following: (1) U.S. utility patent application serial no. 09/454,139, attorney docket no. 25791.3.02, filed on 12/3/1999, which claimed the benefit of the filing date of U.S. provisional patent  
15 application no. 60/111,293, attorney docket no. 25791.3, filed on 12/7/1998; (2) U.S. utility patent application serial no. 09/510,913, attorney docket no. 25791.7.02, filed on 2/23/2000, which claimed the benefit of the filing date of U.S. provisional application no. 60/121,702, filed on 2/25/1999; (3) U.S. utility patent application serial no. 09/502,350, attorney docket no. 25791.8.02, filed on 2/10/2000, which  
20 claimed the benefit of the filing date of U.S. provisional application no. 60/119,611, attorney docket no. 25791.8; (4) U.S. utility patent application serial no. 09/440,338, attorney docket no. 25791.9.02, filed on 11/15/1999, which claimed the benefit of the filing date of U.S. provisional application no. 60/108,558, attorney docket no. 25791.9, filed on 11/16.1998; (5) U.S. provisional patent application no. 60/183,546,  
25 filed on 2/18/2000; (6) U.S. utility patent application no. 09/523,460, attorney docket no. 25791.11.02, filed on 3/10/2000, which claimed the benefit of the filing date of U.S. provisional application no. 60/124,042, filed on 3/11/1999; (7) U.S. utility patent application no. 09/512,895, attorney docket no. 25791.12.02, filed on 2/24/2000, which claimed the benefit of the filing dates of U.S. provisional application no.  
30 60/121,841, attorney docket no. 25791.12, filed on 2/26/1999 and U.S. provisional application no. 60/154,047, attorney docket no. 25791.29, filed on 9/16/1999; (8) U.S. utility application no. 09/511,941, attorney docket no. 25791.16.02, filed on 2/24/2000, which claimed the benefit of the filing date of U.S. provisional serial no. 60/121,907, attorney docket no. 25791.16, filed on 2/26/1999; (9) U.S. utility patent  
35 application no. 09/588,946, attorney docket no. 25791.17.02, filed on June 7, 2000,

which claimed the benefit of the filing date of U.S. provisional patent application serial no. 60/137,998, attorney docket no. 25791.17, filed on 6/7/1999; (10) U.S. utility patent application no. 09/559,122, attorney docket no. 25791.23.02, filed on 4/26/2000, which claimed the benefit of the filing date of U.S. provisional application  
5 no. 60/131,106, attorney docket no. 25791.23, filed on 4/26/1999; (11) U.S. provisional application no. 60/146,203, attorney docket no. 25791.25, filed on 7/29/1999; (12) U.S. provisional application no. 60/143,039, attorney docket no. 25791.26, filed on 7/9/1999; (13) U.S. provisional patent application serial no. 60/162,671, attorney docket no. 25791.27, filed on 11/1/1999; (14) U.S. provisional  
10 application no. 60/159,039, attorney docket no. 25791.36, filed on 10/12,1999; (15) U.S. provisional patent application no. 60/159,033, attorney docket no. 25791.37, filed on 10/12/1999; and (16) U.S. provisional patent application no. 60/165,228, attorney docket no. 25791.39, filed on 11/12/1999, the disclosures of which are incorporated herein by reference.

15           The expansion cone 2335 is preferably coupled to the support member 2325. The expansion cone 2335 is further preferably removably coupled to the expandable tubular member 2330. The expansion cone 2335 is preferably adapted to radially expand the expandable tubular member 2330 when the expansion cone 2335 is axially displaced relative to the expandable tubular member 2330.

20           In a preferred embodiment, the expansion cone 2335 is provided substantially as disclosed in one or more of the following: (1) U.S. utility patent application serial no. 09/454,139, attorney docket no. 25791.3.02, filed on 12/3/1999, which claimed the benefit of the filing date of U.S. provisional patent application no. 60/111,293, attorney docket no. 25791.3, filed on 12/7/1998; (2) U.S.  
25 utility patent application serial no. 09/510,913, attorney docket no. 25791.7.02, filed on 2/23/2000, which claimed the benefit of the filing date of U.S. provisional application no. 60/121,702, filed on 2/25/1999; (3) U.S. utility patent application serial no. 09/502,350, attorney docket no. 25791.8.02, filed on 2/10/2000, which claimed the benefit of the filing date of U.S. provisional application no. 60/119,611,  
30 attorney docket no. 25791.8; (4) U.S. utility patent application serial no. 09/440,338, attorney docket no. 25791.9.02, filed on 11/15/1999, which claimed the benefit of the filing date of U.S. provisional application no. 60/108,558, attorney docket no. 25791.9, filed on 11/16.1998; (5) U.S. provisional patent application no. 60/183,546, filed on 2/18/2000; (6) U.S. utility patent application no. 09/523,460, attorney docket  
35 no. 25791.11.02, filed on 3/10/2000, which claimed the benefit of the filing date of



U.S. provisional application no. 60/124,042, filed on 3/11/1999; (7) U.S. utility patent application no. 09/512,895, attorney docket no. 25791.12.02, filed on 2/24/2000, which claimed the benefit of the filing dates of U.S. provisional application no. 60/121,841, attorney docket no. 25791.12, filed on 2/26/1999 and U.S. provisional  
5 application no. 60/154,047, attorney docket no. 25791.29, filed on 9/16/1999; (8) U.S. utility application no. 09/511,941, attorney docket no. 25791.16.02, filed on 2/24/2000, which claimed the benefit of the filing date of U.S. provisional serial no. 60/121,907, attorney docket no. 25791.16, filed on 2/26/1999; (9) U.S. utility patent application no. 09/588,946, attorney docket no. 25791.17.02, filed on June 7, 2000,  
10 which claimed the benefit of the filing date of U.S. provisional patent application serial no. 60/137,998, attorney docket no. 25791.17, filed on 6/7/1999; (10) U.S. utility patent application no. 09/559,122, attorney docket no. 25791.23.02, filed on 4/26/2000, which claimed the benefit of the filing date of U.S. provisional application no. 60/131,106, attorney docket no. 25791.23, filed on 4/26/1999; (11) U.S.  
15 provisional application no. 60/146,203, attorney docket no. 25791.25, filed on 7/29/1999; (12) U.S. provisional application no. 60/143,039, attorney docket no. 25791.26, filed on 7/9/1999; (13) U.S. provisional patent application serial no. 60/162,671, attorney docket no. 25791.27, filed on 11/1/1999; (14) U.S. provisional application no. 60/159,039, attorney docket no. 25791.36, filed on 10/12,1999; (15)  
20 U.S. provisional patent application no. 60/159,033, attorney docket no. 25791.37, filed on 10/12/1999; and (16) U.S. provisional patent application no. 60/165,228, attorney docket no. 25791.39, filed on 11/12/1999, the disclosures of which are incorporated herein by reference.

The upper sealing member 2340 is coupled to the outside surface of the  
25 upper section 2360 of the expandable tubular member 2330. The upper sealing member 2340 is preferably adapted to fluidically seal the interface between the radially expanded upper section 2360 of the expandable tubular member 2330 and the wellbore casing 2300. The upper sealing member 2340 may be any number of conventional commercially available sealing members. In a preferred embodiment,  
30 the upper sealing member 2340 is a viton rubber in order to optimally provide load carrying and pressure sealing capacity.

The lower sealing member 2345 is preferably coupled to the outside surface of the upper section 2360 of the expandable tubular member 2330. The lower sealing member 2340 is preferably adapted to fluidically seal the interface between  
35 the radially expanded upper section 2360 of the expandable tubular member 2330

and the open hole wellbore section 2305. The lower sealing member 2345 may be any number of conventional commercially available sealing members. In a preferred embodiment, the lower sealing member 2345 is viton rubber in order to optimally provide load carrying and sealing capacity.

5           As illustrated in FIG. 23a, the apparatus 2320 is preferably positioned within the wellbore casing 2300 and the open hole wellbore section 2305 with the expandable tubular member 2330 positioned in overlapping relation to the wellbore casing 2300.

10           As illustrated in FIG. 23b, in a preferred embodiment, a quantity of a hardenable fluidic sealing material 2365 is then injected into the open hole wellbore section 2305 proximate to the lower section 2350 of the expandable tubular member 2330. The sealing material 2365 may be any number of conventional commercially available sealing materials such as, for example, cement and/or epoxy resin. In a preferred embodiment, the hardenable fluidic sealing material 2365 at least partially  
15 enters the slots provided in the lower section 2350 of the expandable tubular member 2330.

20           As illustrated in FIG. 23c, the hardenable fluidic sealing material 2365 is preferably then permitted to at least partially cure. In this manner, the lower section 2350 of the expandable tubular member 2330 is anchored to the open hole wellbore section 2305.

25           In an alternative embodiment, a compressible cement and/or epoxy is then injected into the annular space between the unexpanded portion of the tubular member 2330 and the wellbore casing 2300. The compressible cement and/or epoxy is then permitted to at least partially cure prior to the initiation of the radial expansion process. In this manner, an annular structural support and fluidic seal is provided around the tubular member 2330.

30           As illustrated in FIG. 23d, in a preferred embodiment, the expansion cone 2335 is then axially displaced by applying an axial force to the support member 2325. In a preferred embodiment, the axial displacement of the expansion cone 2335 radially expands the expandable tubular member 2330 into intimate contact with the walls of the wellbore casing 2300.

35           As illustrated in FIG. 23e, in a preferred embodiment, after the expandable tubular member 2330 has been completely radially expanded by the axial displacement of the expansion cone 2335, a new section of wellbore casing is formed that preferably includes the radially expanded tubular member 2330 and an

outer annular layer of a fluidic sealing material. More generally, the apparatus 2320 is used to repair or form wellbore casings, pipelines, and structural supports.

Referring to FIGS. 24a to 24c, an alternative embodiment of an apparatus and method for coupling an expandable tubular member to a preexisting structure will now be described. Referring to Fig. 24a, a wellbore casing 2400 and an open hole wellbore section 2405 are positioned within a subterranean formation 2410. The wellbore casing 2400 and the open hole wellbore section 2405 may be positioned in any orientation from the vertical direction to approximately the horizontal direction.

In a preferred embodiment, an apparatus 2420 is utilized to form a new section of wellbore casing within the open hole wellbore section 2405. More generally, the apparatus 2420 is preferably utilized to form or repair wellbore casings, pipelines, or structural supports.

The apparatus 2420 preferably includes a support member 2425, an expandable tubular member 2430, an expansion cone 2435, a coupling 2440, a packer 2445, a mass 2450, one or more upper sealing members 2455, and one or more sealing members 2460.

The support member 2425 is preferably adapted to be coupled to a surface location. The support member 2425 is further coupled to the expansion cone 2435. The support member 2425 is preferably adapted to convey electrical, communication, and/or hydraulic signals to and/or from the packer 2445. The support member 2425 may, for example, be conventional commercially available slick wire, braided wire, coiled tubing, or drilling stock material.

The expandable tubular member 2430 is removably coupled to the expansion cone 2435 and the packer 2445. The expandable tubular member 2430 is further preferably coupled to the mass 2450. In a preferred embodiment, the expandable tubular member 2430 further includes one or more upper and lower sealing members, 2455 and 2460, on the outside surface of the expandable tubular member 2430 in order to optimally seal the interface between the expandable tubular member 2430 and the wellbore casing 2400 and the open hole wellbore section 2405.

In a preferred embodiment, the expandable tubular member 2430 further includes a lower section 2465, an intermediate section 2470, and an upper section 2430. In a preferred embodiment, the wall thicknesses of the lower and intermediate sections, 2465 and 2470, are less than the wall thickness of the upper

section 2475 in order to optimally facilitate the radial expansion of the expandable tubular member 2430. In a preferred embodiment, the lower section 2465 of the expandable tubular member 2430 is coupled to the mass 2450.

5 In a preferred embodiment, the expandable tubular member 2430 is further provided substantially as disclosed in one or more of the following:

The expansion cone 2435 is preferably coupled to the support member 2425 and the coupling 2440. The expansion cone 2435 is further preferably removably coupled to the expandable tubular member 2430. The expansion cone 2435 is preferably adapted to radially expand the expandable tubular member 2430 when  
10 the expansion cone 2435 is axially displaced relative to the expandable tubular member 2430.

In a preferred embodiment, the expansion cone 2435 is provided substantially as disclosed in one or more of the following: (1) U.S. utility patent application serial no. 09/454,139, attorney docket no. 25791.3.02, filed on  
15 12/3/1999, which claimed the benefit of the filing date of U.S. provisional patent application no. 60/111,293, attorney docket no. 25791.3, filed on 12/7/1998; (2) U.S. utility patent application serial no. 09/510,913, attorney docket no. 25791.7.02, filed on 2/23/2000, which claimed the benefit of the filing date of U.S. provisional application no. 60/121,702, filed on 2/25/1999; (3) U.S. utility patent application  
20 serial no. 09/502,350, attorney docket no. 25791.8.02, filed on 2/10/2000, which claimed the benefit of the filing date of U.S. provisional application no. 60/119,611, attorney docket no. 25791.8; (4) U.S. utility patent application serial no. 09/440,338, attorney docket no. 25791.9.02, filed on 11/15/1999, which claimed the benefit of the filing date of U.S. provisional application no. 60/108,558, attorney docket no.  
25 25791.9, filed on 11/16.1998; (5) U.S. provisional patent application no. 60/183,546, filed on 2/18/2000; (6) U.S. utility patent application no. 09/523,460, attorney docket no. 25791.11.02, filed on 3/10/2000, which claimed the benefit of the filing date of U.S. provisional application no. 60/124,042, filed on 3/11/1999; (7) U.S. utility patent application no. 09/512,895, attorney docket no. 25791.12.02, filed on 2/24/2000,  
30 which claimed the benefit of the filing dates of U.S. provisional application no. 60/121,841, attorney docket no. 25791.12, filed on 2/26/1999 and U.S. provisional application no. 60/154,047, attorney docket no. 25791.29, filed on 9/16/1999; (8) U.S. utility application no. 09/511,941, attorney docket no. 25791.16.02, filed on 2/24/2000, which claimed the benefit of the filing date of U.S. provisional serial no.  
35 60/121,907, attorney docket no. 25791.16, filed on 2/26/1999; (9) U.S. utility patent

application no. 09/588,946, attorney docket no. 25791.17.02, filed on June 7, 2000, which claimed the benefit of the filing date of U.S. provisional patent application serial no. 60/137,998, attorney docket no. 25791.17, filed on 6/7/1999; (10) U.S. utility patent application no. 09/559,122, attorney docket no. 25791.23.02, filed on  
5 4/26/2000, which claimed the benefit of the filing date of U.S. provisional application no. 60/131,106, attorney docket no. 25791.23, filed on 4/26/1999; (11) U.S. provisional application no. 60/146,203, attorney docket no. 25791.25, filed on 7/29/1999; (12) U.S. provisional application no. 60/143,039, attorney docket no. 25791.26, filed on 7/9/1999; (13) U.S. provisional patent application serial no.  
10 60/162,671, attorney docket no. 25791.27, filed on 11/1/1999; (14) U.S. provisional application no. 60/159,039, attorney docket no. 25791.36, filed on 10/12,1999; (15) U.S. provisional patent application no. 60/159,033, attorney docket no. 25791.37, filed on 10/12/1999; and (16) U.S. provisional patent application no. 60/165,228, attorney docket no. 25791.39, filed on 11/12/1999, the disclosures of which are  
15 incorporated herein by reference.

The coupling 2440 is preferably coupled to the support member 2425 and the expansion cone 2435. The coupling 2440 is preferably adapted to convey electrical, communication, and/or hydraulic signals to and/or from the packer 2445. The coupling 2440 may be any number of conventional support members such as,  
20 for example, commercially available slick wire, braided wire, coiled tubing, or drilling stock material.

The packer 2445 is coupled to the coupling 2440. The packer 2445 is further removably coupled to the lower section 2465 of the expandable wellbore casing 2430. The packer 2445 is preferably adapted to provide sufficient frictional force to  
25 support the lower section 2465 of the expandable wellbore casing 2430 and the mass 2450. The packer 2445 may be any number of conventional commercially available packers. In a preferred embodiment, the packer 2445 is an RTTS packer available from Halliburton Energy Services in order to optimally provide multiple sets and releases. In an alternative embodiment, hydraulic slips may be substituted for,  
30 or used to supplement, the packer 2445.

The mass 2450 is preferably coupled to the lower section 2465 of the expandable tubular member 2430. The mass 2450 is preferably selected to provide a tensile load on the lower section 2465 of the expandable tubular member 2430 that ranges from about 50 to 100 % of the yield point of the upper section 2475 of  
35 the expandable tubular member 2430. In this manner, when the packer 2445 is

released, the axial force provided by the mass 2450 optimally radially expands and extrudes the expandable tubular member 2430 off of the expansion cone 2435.

The upper sealing member 2455 is preferably coupled to the outside surface of the upper section 2475 of the expandable tubular member 2430. The upper  
5 sealing member 2455 is preferably adapted to fluidically seal the interface between the radially expanded upper section 2475 of the expandable tubular member 2430 and the wellbore casing 2400. The upper sealing member 2455 may be any number of conventional commercially available sealing members. In a preferred embodiment, the upper sealing member 2455 is viton rubber in order to optimally  
10 provide load carrying and pressure sealing capacity.

The lower sealing member 2460 is preferably coupled to the outside surface of the upper section 2475 of the expandable tubular member 2430. The lower sealing member 2460 is preferably adapted to fluidically seal the interface between the radially expanded upper section 2475 of the expandable tubular member 2430  
15 and the open hole wellbore section 2405. The lower sealing member 2460 may be any number of conventional commercially available sealing members. In a preferred embodiment, the lower sealing member 2460 is viton rubber in order to optimally provide lead bearing and sealing capacity.

As illustrated in FIG. 24a, the apparatus 2420 is preferably positioned within  
20 the wellbore casing 2400 and the open hole wellbore section 2405 with the expandable tubular member 2430 positioned in overlapping relation to the wellbore casing 2400. In a preferred embodiment, the weight of the mass 2450 is supported by the support member 2425, the expansion cone 2435, the coupling 2440, the packer 2445, and the lower section 2465 of the expandable tubular member 2430.  
25 In this manner, the intermediate section 2470 of the expandable tubular member 2430 preferably does not support any of the weight of the mass 2450.

As illustrated in FIG. 24b, in a preferred embodiment, the packer 2445 is then released from connection with the lower section 2465 of the expandable tubular member 2430. In this manner, the mass 2450 is preferably now supported by the  
30 support member 2425, expansion cone 2435, and the lower and intermediate sections, 2465 and 2470, of the expandable tubular member 2430. In a preferred embodiment, the weight of the mass 2450 then causes the expandable tubular member 2430 to be radially expanded by, and extruded off of, the expansion cone 2435. In a preferred embodiment, during the extrusion process, the position of the

support member 2425 is adjusted to ensure an overlapping relation between the expandable tubular member 2430 and the wellbore casing 2400.

5 In an alternative embodiment, a compressible cement and/or epoxy is injected into the annular space between the unexpanded portion of the tubular member 2430 and the wellbore casing 2400 before and/or during the extrusion process. The compressible cement and/or epoxy is then preferably permitted to at least partially cure prior to the initiation of the radial expansion process. In this manner, an annular structural support and fluidic seal is provided around the tubular member 2430.

10 As illustrated in FIG. 24c, in a preferred embodiment, after the expandable tubular member 2430 has been completely extruded off of the expansion cone 2435, a new section of wellbore casing is formed that preferably includes the radially expanded tubular member 2430 and an outer annular layer of a fluidic sealing material. More generally, the apparatus 2420 is used to repair or form wellbore casings, pipelines, and structural supports.

15 In an alternative embodiment, the mass 2450 is positioned on top of the upper section 2475 of the tubular member 2430. In a preferred embodiment, the mass 2450 is fabricated from a thick walled tubular member that is concentric with respect to the support member 2425, and also rests on top of the upper section 20 2475 of the tubular member 2430. In this manner, when the expansion cone 2435 exits the tubular member 2430, the expansion cone will carry the mass 2450 out of the wellbore 2405.

Referring to FIGS. 25a to 25c, an alternative embodiment of an apparatus and method for coupling an expandable tubular member to a preexisting structure will now be described. Referring to Fig. 25a, a wellbore casing 2500 and an open hole wellbore section 2505 are positioned within a subterranean formation 2510. The wellbore casing 2500 and the open hole wellbore section 2505 may be positioned in any orientation from the vertical direction to approximately the horizontal direction.

30 In a preferred embodiment, an apparatus 2520 is utilized to form a new section of wellbore casing within the open hole wellbore section 2505. More generally, the apparatus 2520 is preferably utilized to form or repair wellbore casings, pipelines, or structural supports.

35 The apparatus 2520 preferably includes a support member 2525, an expandable tubular member 2530, an expansion cone 2535, a chamber 2440, an

end plate 2545, one or more upper sealing members 2555, and one or more sealing members 2560.

The support member 2525 is preferably adapted to be coupled to a surface location. The support member 2525 is further coupled to the expansion cone 2535.

5 The support member 2525 is preferably adapted to convey fluidic materials to and/or from the chamber 2540. The support member 2525 may, for example, be conventional commercially available slick wire, braided wire, coiled tubing, or drilling stock material.

10 The expandable tubular member 2530 is removably coupled to the expansion cone 2535. In a preferred embodiment, the expandable tubular member 2530 further includes one or more upper and lower sealing members, 2555 and 2560, on the outside surface of the expandable tubular member 2530 in order to optimally seal the interface between the expandable tubular member 2530 and the wellbore casing 2500 and the open hole wellbore section 2505.

15 In a preferred embodiment, the expandable tubular member 2530 further includes a lower section 2565, an intermediate section 2570, and an upper section 2530. In a preferred embodiment, the wall thicknesses of the lower and intermediate sections, 2565 and 2570, are less than the wall thickness of the upper section 2575 in order to optimally facilitate the radial expansion of the expandable  
20 tubular member 2530.

In a preferred embodiment, the lower section 2565 of the expandable tubular member 2530 further includes the chamber 2540 and the end plate 2545.

In a preferred embodiment, the expandable tubular member 2530 is further provided substantially as disclosed in one or more of the following: (1) U.S. utility  
25 patent application serial no. 09/454,139, attorney docket no. 25791.3.02, filed on 12/3/1999, which claimed the benefit of the filing date of U.S. provisional patent application no. 60/111,293, attorney docket no. 25791.3, filed on 12/7/1998; (2) U.S. utility patent application serial no. 09/510,913, attorney docket no. 25791.7.02, filed on 2/23/2000, which claimed the benefit of the filing date of U.S. provisional  
30 application no. 60/121,702, filed on 2/25/1999; (3) U.S. utility patent application serial no. 09/502,350, attorney docket no. 25791.8.02, filed on 2/10/2000, which claimed the benefit of the filing date of U.S. provisional application no. 60/119,611, attorney docket no. 25791.8; (4) U.S. utility patent application serial no. 09/440,338, attorney docket no. 25791.9.02, filed on 11/15/1999, which claimed the benefit of  
35 the filing date of U.S. provisional application no. 60/108,558, attorney docket no.



25791.9, filed on 11/16.1998; (5) U.S. provisional patent application no. 60/183,546, filed on 2/18/2000; (6) U.S. utility patent application no. 09/523,460, attorney docket no. 25791.11.02, filed on 3/10/2000, which claimed the benefit of the filing date of U.S. provisional application no. 60/124,042, filed on 3/11/1999; (7) U.S. utility patent  
 5 application no. 09/512,895, attorney docket no. 25791.12.02, filed on 2/24/2000, which claimed the benefit of the filing dates of U.S. provisional application no. 60/121,841, attorney docket no. 25791.12, filed on 2/26/1999 and U.S. provisional application no. 60/154,047, attorney docket no. 25791.29, filed on 9/16/1999; (8) U.S. utility application no. 09/511,941, attorney docket no. 25791.16.02, filed on  
 10 2/24/2000, which claimed the benefit of the filing date of U.S. provisional serial no. 60/121,907, attorney docket no. 25791.16, filed on 2/26/1999; (9) U.S. utility patent application no. 09/588,946, attorney docket no. 25791.17.02, filed on June 7, 2000, which claimed the benefit of the filing date of U.S. provisional patent application serial no. 60/137,998, attorney docket no. 25791.17, filed on 6/7/1999; (10) U.S.  
 15 utility patent application no. 09/559,122, attorney docket no. 25791.23.02, filed on 4/26/2000, which claimed the benefit of the filing date of U.S. provisional application no. 60/131,106, attorney docket no. 25791.23, filed on 4/26/1999; (11) U.S. provisional application no. 60/146,203, attorney docket no. 25791.25, filed on 7/29/1999; (12) U.S. provisional application no. 60/143,039, attorney docket no.  
 20 25791.26, filed on 7/9/1999; (13) U.S. provisional patent application serial no. 60/162,671, attorney docket no. 25791.27, filed on 11/1/1999; (14) U.S. provisional application no. 60/159,039, attorney docket no. 25791.36, filed on 10/12,1999; (15) U.S. provisional patent application no. 60/159,033, attorney docket no. 25791.37, filed on 10/12/1999; and (16) U.S. provisional patent application no. 60/165,228,  
 25 attorney docket no. 25791.39, filed on 11/12/1999, the disclosures of which are incorporated herein by reference.

The expansion cone 2535 is preferably coupled to the support member 2525. The expansion cone 2535 is further preferably removably coupled to the expandable tubular member 2530. The expansion cone 2535 is preferably adapted  
 30 to radially expand the expandable tubular member 2530 when the expansion cone 2535 is axially displaced relative to the expandable tubular member 2530. The expansion cone 2535 is further preferably adapted to convey fluidic materials to and/or from the chamber 2540.

In a preferred embodiment, the expansion cone 2535 is provided  
 35 substantially as disclosed in one or more of the following: (1) U.S. utility patent

application serial no. 09/454,139, attorney docket no. 25791.3.02, filed on 12/3/1999, which claimed the benefit of the filing date of U.S. provisional patent application no. 60/111,293, attorney docket no. 25791.3, filed on 12/7/1998; (2) U.S. utility patent application serial no. 09/510,913, attorney docket no. 25791.7.02, filed  
5 on 2/23/2000, which claimed the benefit of the filing date of U.S. provisional application no. 60/121,702, filed on 2/25/1999; (3) U.S. utility patent application serial no. 09/502,350, attorney docket no. 25791.8.02, filed on 2/10/2000, which claimed the benefit of the filing date of U.S. provisional application no. 60/119,611, attorney docket no. 25791.8; (4) U.S. utility patent application serial no. 09/440,338,  
10 attorney docket no. 25791.9.02, filed on 11/15/1999, which claimed the benefit of the filing date of U.S. provisional application no. 60/108,558, attorney docket no. 25791.9, filed on 11/16.1998; (5) U.S. provisional patent application no. 60/183,546, filed on 2/18/2000; (6) U.S. utility patent application no. 09/523,460, attorney docket no. 25791.11.02, filed on 3/10/2000, which claimed the benefit of the filing date of  
15 U.S. provisional application no. 60/124,042, filed on 3/11/1999; (7) U.S. utility patent application no. 09/512,895, attorney docket no. 25791.12.02, filed on 2/24/2000, which claimed the benefit of the filing dates of U.S. provisional application no. 60/121,841, attorney docket no. 25791.12, filed on 2/26/1999 and U.S. provisional application no. 60/154,047, attorney docket no. 25791.29, filed on 9/16/1999; (8)  
20 U.S. utility application no. 09/511,941, attorney docket no. 25791.16.02, filed on 2/24/2000, which claimed the benefit of the filing date of U.S. provisional serial no. 60/121,907, attorney docket no. 25791.16, filed on 2/26/1999; (9) U.S. utility patent application no. 09/588,946, attorney docket no. 25791.17.02, filed on June 7, 2000, which claimed the benefit of the filing date of U.S. provisional patent application  
25 serial no. 60/137,998, attorney docket no. 25791.17, filed on 6/7/1999; (10) U.S. utility patent application no. 09/559,122, attorney docket no. 25791.23.02, filed on 4/26/2000, which claimed the benefit of the filing date of U.S. provisional application no. 60/131,106, attorney docket no. 25791.23, filed on 4/26/1999; (11) U.S. provisional application no. 60/146,203, attorney docket no. 25791.25, filed on  
30 7/29/1999; (12) U.S. provisional application no. 60/143,039, attorney docket no. 25791.26, filed on 7/9/1999; (13) U.S. provisional patent application serial no. 60/162,671, attorney docket no. 25791.27, filed on 11/1/1999; (14) U.S. provisional application no. 60/159,039, attorney docket no. 25791.36, filed on 10/12,1999; (15) U.S. provisional patent application no. 60/159,033, attorney docket no. 25791.37,  
35 filed on 10/12/1999; and (16) U.S. provisional patent application no. 60/165,228,

attorney docket no. 25791.39, filed on 11/12/1999, the disclosures of which are incorporated herein by reference.

The chamber 2540 is defined by the interior portion of the lower section 2565 of the expandable tubular member 2530 below the expansion cone 2535 and above  
5 the end plate 2545. The chamber 2540 is preferably adapted to contain a quantity of a fluidic materials having a higher density than the fluidic materials outside of the expandable tubular member 2530.

The upper sealing member 2555 is preferably coupled to the outside surface of the upper section 2575 of the expandable tubular member 2530. The upper  
10 sealing member 2555 is preferably adapted to fluidically seal the interface between the radially expanded upper section 2575 of the expandable tubular member 2530 and the wellbore casing 2500. The upper sealing member 2555 may be any number of conventional commercially available sealing members. In a preferred embodiment, the upper sealing member 2555 is viton rubber in order to optimally  
15 provide load carrying and pressure sealing capacity.

The lower sealing member 2560 is preferably coupled to the outside surface of the upper section 2575 of the expandable tubular member 2530. The lower  
sealing member 2560 is preferably adapted to fluidically seal the interface between the radially expanded upper section 2575 of the expandable tubular member 2530  
20 and the open hole wellbore section 2505. The lower sealing member 2560 may be any number of conventional commercially available sealing members. In a preferred embodiment, the lower sealing member 2560 is viton rubber in order to optimally provide load carrying and pressure sealing capacity.

As illustrated in FIG. 25a, the apparatus 2520 is preferably positioned within  
25 the wellbore casing 2500 and the open hole wellbore section 2505 with the expandable tubular member 2530 positioned in overlapping relation to the wellbore casing 2500.

As illustrated in FIG. 25b, a quantity of a fluidic material 2580 having a density greater than the density of the fluidic material within the region 2585 outside  
30 of the expandable tubular member 2530 is injected into the chamber 2540. In a preferred embodiment, the difference in hydrostatic pressure between the chamber 2540 and the region 2585, due to the differences in fluid densities of these regions, causes the expandable tubular member 2530 to be radially expanded by, and extruded off of, the expansion cone 2535. In a preferred embodiment, during the  
35 extrusion process, the position of the support member 2525 is adjusted to ensure an

overlapping relation between the expandable tubular member 2530 and the wellbore casing 2500. In a preferred embodiment, the quantity of the fluidic material 2580 initially injected into the chamber 2540 is subsequently increased as the size of the chamber 2540 increases during the extrusion process. In this manner, high  
5 pressure pumping equipment is typically not required, or the need for it is at least minimized. Rather, in an exemplary embodiment, a column of the fluidic material 2580 is maintained within the support member 2525.

In an alternative embodiment, a compressible cement and/or epoxy is injected into the annular space between the unexpanded portion of the tubular  
10 member 2530 and the wellbore casing 2500 before and/or during the extrusion process. The compressible cement and/or epoxy is then preferably permitted to at least partially cure prior to the initiation of the radial expansion process. In this manner, an annular structural support and fluidic seal is provided around the tubular member 2530.

As illustrated in FIG. 25c, in a preferred embodiment, after the expandable  
15 tubular member 2530 has been completely extruded off of the expansion cone 2535, a new section of wellbore casing is formed that preferably includes the radially expanded tubular member 2530 and an outer annular layer of a fluidic sealing material. More generally, the apparatus 2520 is used to repair or form wellbore  
20 casings, pipelines, and structural supports.

Referring to FIGS. 26a to 26c, an alternative embodiment of an apparatus and method for coupling an expandable tubular member to a preexisting structure will now be described. Referring to Fig. 26a, a wellbore casing 2600 and an open  
hole wellbore section 2605 are positioned within a subterranean formation 2610.  
25 The wellbore casing 2600 and the open hole wellbore section 2605 may be positioned in any orientation from the vertical direction to approximately the horizontal direction.

In a preferred embodiment, an apparatus 2620 is utilized to form a new  
section of wellbore casing within the open hole wellbore section 2605. More  
30 generally, the apparatus 2620 is preferably utilized to form or repair wellbore casings, pipelines, or structural supports.

The apparatus 2620 preferably includes a support member 2625, an expandable tubular member 2630, an expansion cone 2635, a slip joint 2640, an end plate 2545, a chamber 2650, one or more slip members 2655, one or more

sealing members 2670, one or more upper sealing members 2675, and one or more lower sealing members 2680.

The support member 2625 is preferably adapted to be coupled to a surface location. The support member 2625 is further coupled to the expansion cone 2635.

5 The support member 2625 is preferably adapted to convey fluidic materials to and/or from the chamber 2640. The support member 2625 may, for example, be conventional commercially available slick wire, braided wire, coiled tubing, or drilling stock material.

10 The expandable tubular member 2630 is removably coupled to the expansion cone 2635. In a preferred embodiment, the expandable tubular member 2630 further includes one or more upper and lower sealing members, 2675 and 2680, on the outside surface of the expandable tubular member 2630 in order to optimally seal the interface between the expandable tubular member 2630 and the wellbore casing 2600 and the open hole wellbore section 2605.

15 In a preferred embodiment, the expandable tubular member 2630 further includes a lower section 2685, an intermediate section 2690, and an upper section 2695. In a preferred embodiment, the wall thicknesses of the lower and intermediate sections, 2685 and 2690, are less than the wall thickness of the upper section 2695 in order to optimally facilitate the radial expansion of the expandable tubular member 2630.

20 In a preferred embodiment, the lower section 2685 of the expandable tubular member 2630 houses the slip joint 2640, the end plate 2645, the slips 2655, and the sealing members 2670. In a preferred embodiment, the interior portion of the lower section 2685 of the expandable tubular member 2630 below the expansion cone 2635 and above the end plate defines the chamber 2650. In a preferred embodiment, the lower section 2685 of the expandable tubular member 2630 further includes one or more of the anchoring devices described above with reference to FIGS. 1a to 25c.

25 In a preferred embodiment, the expandable tubular member 2630 is further provided substantially as disclosed in one or more of the following: (1) U.S. utility patent application serial no. 09/454,139, attorney docket no. 25791.3.02, filed on 12/3/1999, which claimed the benefit of the filing date of U.S. provisional patent application no. 60/111,293, attorney docket no. 25791.3, filed on 12/7/1998; (2) U.S. utility patent application serial no. 09/510,913, attorney docket no. 25791.7.02, filed on 2/23/2000, which claimed the benefit of the filing date of U.S. provisional

application no. 60/121,702, filed on 2/25/1999; (3) U.S. utility patent application serial no. 09/502,350, attorney docket no. 25791.8.02, filed on 2/10/2000, which claimed the benefit of the filing date of U.S. provisional application no. 60/119,611, attorney docket no. 25791.8; (4) U.S. utility patent application serial no. 09/440,338, attorney docket no. 25791.9.02, filed on 11/15/1999, which claimed the benefit of the filing date of U.S. provisional application no. 60/108,558, attorney docket no. 25791.9, filed on 11/16.1998; (5) U.S. provisional patent application no. 60/183,546, filed on 2/18/2000; (6) U.S. utility patent application no. 09/523,460, attorney docket no. 25791.11.02, filed on 3/10/2000, which claimed the benefit of the filing date of U.S. provisional application no. 60/124,042, filed on 3/11/1999; (7) U.S. utility patent application no. 09/512,895, attorney docket no. 25791.12.02, filed on 2/24/2000, which claimed the benefit of the filing dates of U.S. provisional application no. 60/121,841, attorney docket no. 25791.12, filed on 2/26/1999 and U.S. provisional application no. 60/154,047, attorney docket no. 25791.29, filed on 9/16/1999; (8) U.S. utility application no. 09/511,941, attorney docket no. 25791.16.02, filed on 2/24/2000, which claimed the benefit of the filing date of U.S. provisional serial no. 60/121,907, attorney docket no. 25791.16, filed on 2/26/1999; (9) U.S. utility patent application no. 09/588,946, attorney docket no. 25791.17.02, filed on June 7, 2000, which claimed the benefit of the filing date of U.S. provisional patent application serial no. 60/137,998, attorney docket no. 25791.17, filed on 6/7/1999; (10) U.S. utility patent application no. 09/559,122, attorney docket no. 25791.23.02, filed on 4/26/2000, which claimed the benefit of the filing date of U.S. provisional application no. 60/131,106, attorney docket no. 25791.23, filed on 4/26/1999; (11) U.S. provisional application no. 60/146,203, attorney docket no. 25791.25, filed on 7/29/1999; (12) U.S. provisional application no. 60/143,039, attorney docket no. 25791.26, filed on 7/9/1999; (13) U.S. provisional patent application serial no. 60/162,671, attorney docket no. 25791.27, filed on 11/1/1999; (14) U.S. provisional application no. 60/159,039, attorney docket no. 25791.36, filed on 10/12,1999; (15) U.S. provisional patent application no. 60/159,033, attorney docket no. 25791.37, filed on 10/12/1999; and (16) U.S. provisional patent application no. 60/165,228, attorney docket no. 25791.39, filed on 11/12/1999, the disclosures of which are incorporated herein by reference.

The expansion cone 2635 is preferably coupled to the support member 2625 and the slip joint 2640. The expansion cone 2635 is further preferably removably coupled to the expandable tubular member 2630. The expansion cone 2635 is

preferably adapted to radially expand the expandable tubular member 2630 when the expansion cone 2635 is axially displaced relative to the expandable tubular member 2630. The expansion cone 2635 is further preferably adapted to convey fluidic materials to and/or from the chamber 2650.

5           In a preferred embodiment, the expansion cone 2635 is further provided substantially as disclosed in one or more of the following: (1) U.S. utility patent application serial no. 09/454,139, attorney docket no. 25791.3.02, filed on 12/3/1999, which claimed the benefit of the filing date of U.S. provisional patent application no. 60/111,293, attorney docket no. 25791.3, filed on 12/7/1998; (2) U.S.  
10 utility patent application serial no. 09/510,913, attorney docket no. 25791.7.02, filed on 2/23/2000, which claimed the benefit of the filing date of U.S. provisional application no. 60/121,702, filed on 2/25/1999; (3) U.S. utility patent application serial no. 09/502,350, attorney docket no. 25791.8.02, filed on 2/10/2000, which claimed the benefit of the filing date of U.S. provisional application no. 60/119,611,  
15 attorney docket no. 25791.8; (4) U.S. utility patent application serial no. 09/440,338, attorney docket no. 25791.9.02, filed on 11/15/1999, which claimed the benefit of the filing date of U.S. provisional application no. 60/108,558, attorney docket no. 25791.9, filed on 11/16.1998; (5) U.S. provisional patent application no. 60/183,546, filed on 2/18/2000; (6) U.S. utility patent application no. 09/523,460, attorney docket  
20 no. 25791.11.02, filed on 3/10/2000, which claimed the benefit of the filing date of U.S. provisional application no. 60/124,042, filed on 3/11/1999; (7) U.S. utility patent application no. 09/512,895, attorney docket no. 25791.12.02, filed on 2/24/2000, which claimed the benefit of the filing dates of U.S. provisional application no. 60/121,841, attorney docket no. 25791.12, filed on 2/26/1999 and U.S. provisional  
25 application no. 60/154,047, attorney docket no. 25791.29, filed on 9/16/1999; (8) U.S. utility application no. 09/511,941, attorney docket no. 25791.16.02, filed on 2/24/2000, which claimed the benefit of the filing date of U.S. provisional serial no. 60/121,907, attorney docket no. 25791.16, filed on 2/26/1999; (9) U.S. utility patent application no. 09/588,946, attorney docket no. 25791.17.02, filed on June 7, 2000,  
30 which claimed the benefit of the filing date of U.S. provisional patent application serial no. 60/137,998, attorney docket no. 25791.17, filed on 6/7/1999; (10) U.S. utility patent application no. 09/559,122, attorney docket no. 25791.23.02, filed on 4/26/2000, which claimed the benefit of the filing date of U.S. provisional application no. 60/131,106, attorney docket no. 25791.23, filed on 4/26/1999; (11) U.S.  
35 provisional application no. 60/146,203, attorney docket no. 25791.25, filed on

7/29/1999; (12) U.S. provisional application no. 60/143,039, attorney docket no. 25791.26, filed on 7/9/1999; (13) U.S. provisional patent application serial no. 60/162,671, attorney docket no. 25791.27, filed on 11/1/1999; (14) U.S. provisional application no. 60/159,039, attorney docket no. 25791.36, filed on 10/12,1999; (15)  
5 U.S. provisional patent application no. 60/159,033, attorney docket no. 25791.37, filed on 10/12/1999; and (16) U.S. provisional patent application no. 60/165,228, attorney docket no. 25791.39, filed on 11/12/1999, the disclosures of which are incorporated herein by reference.

The slip joint 2640 is coupled to the expansion cone 2635 and the end plate  
10 2645. The slip joint 2640 is preferably adapted to permit the end plate 2645 to be axially displaced relative to the expansion cone 2635. In this manner, the size of the chamber 2650 is variable. The slip joint 2640 may be any number of conventional commercially available slip joints modified in accordance with the teachings of the present disclosure.

15 The slip joint 2640 preferably includes an upper member 2640a, a resilient member 2640b, and a lower member 2640c. The upper member 2640a is coupled to the expansion cone 2635 and the resilient member 2640b. The upper member 2640a is movably coupled to the lower member 2640b. The upper member 2640a preferably includes one or more fluid passages 2640aa that permit the passage of  
20 fluidic materials. The lower member 2640b is coupled to the end plate 2645 and the resilient member 2640b. The lower member 2640b is movably coupled to the upper member 2640a. The lower member 2640b preferably includes one or more fluid passages 2640ba that permit the passage of fluidic materials. The resilient member 2640c is coupled between the upper and lower members, 2640a and 2640b. The  
25 resilient member 2640c is preferably adapted to apply an upward axial force to the end plate 2645.

The end plate 2645 is coupled to the slip joint 2640, the slips 2655, and the sealing members 2670. The end plate 2645 is preferably adapted to seal off a  
30 portion of the interior of the lower section 2685 of the expandable tubular member 2630. The end plate 2645 is further adapted to define, in combination with the expandable tubular member 2630, and the expansion cone 2635, the chamber 2650.

The chamber 2650 is defined by the interior portion of the lower section 2685 of the expandable tubular member 2630 below the expansion cone 2635 and above  
35 the end plate 2645. In a preferred embodiment, the pressurization of the chamber



2650 causes the expansion cone 2635 to be axially displaced and thereby radially expand the expandable tubular member 2630. The chamber 2650 is preferably adapted to move upwardly within the expandable tubular member 2630 as the expansion cone 2635 and end plate 2645 are axially displaced within the  
5 expandable tubular member 2630.

The slips 2655 are coupled to the end plate 2645. The slips 2655 are preferably adapted to permit the end plate 2645 to be displaced in the upward axial direction; but prevent axial displacement of the end plate 2645 in the downward direction. In this manner, the chamber 2650 is pressurized by injecting fluidic  
10 materials into the chamber 2650. Because the end plate 2645 is maintained in a substantially stationary position, relative to the expandable tubular member 2630, during the injection of pressurized fluidic materials into the chamber 2650, the pressurization of the chamber 2650 preferably axially displaces the expansion cone 2635. In a preferred embodiment, when the slip joint 2640 is fully extended, the slip  
15 joint 2640 then displaces the end plate 2645 in the upward axial direction. In a preferred embodiment, when the spring force of the elastic member 2640c of the slip joint 2640 is greater than the fluidic pressurization force within the chamber 2650, the end plate 2645 is displaced in the upward axial direction.

The sealing members 2670 are coupled to the end plate 2645. The sealing  
20 members 2670 are further preferably sealingly coupled to the interior walls of the expandable tubular member 2630. In this manner, the chamber 2650 is optimally pressurized during operation of the apparatus 2620.

The upper sealing member 2675 is preferably coupled to the outside surface of the upper section 2695 of the expandable tubular member 2630. The upper  
25 sealing member 2675 is preferably adapted to fluidically seal the interface between the radially expanded upper section 2695 of the expandable tubular member 2630 and the wellbore casing 2600. The upper sealing member 2675 may be any number of conventional commercially available sealing members. In a preferred embodiment, the upper sealing member 2675 is viton rubber in order to optimally  
30 provide load carrying and pressure sealing capacity.

The lower sealing member 2680 is preferably coupled to the outside surface of the upper section 2695 of the expandable tubular member 2630. The lower  
sealing member 2680 is preferably adapted to fluidically seal the interface between the radially expanded upper section 2695 of the expandable tubular member 2630  
35 and the open hole wellbore section 2605. The lower sealing member 2680 may be

any number of conventional commercially available sealing members. In a preferred embodiment, the lower sealing member 2680 is viton rubber in order to optimally provide load carrying and pressure sealing capacity.

5 As illustrated in FIG. 26a, the apparatus 2620 is preferably positioned within the wellbore casing 2600 and the open hole wellbore section 2605 with the expandable tubular member 2630 positioned in overlapping relation to the wellbore casing 2600. In a preferred embodiment, the lower section 2685 of the expandable tubular member 2630 is then anchored to the open hole wellbore section 2605 using one or more of the apparatus and methods described above with reference to FIGS.  
10 1a to 25c.

As illustrated in FIG. 26b, the radial expansion of the expandable tubular member 2630 is then initiated by: (1) applying an upward axial force to the expansion cone 2635; and/or (2) pressurizing the chamber 2650 by injecting a pressurized fluidic material into the chamber 2650.

15 In a preferred embodiment, the expandable tubular member 2630 is radially expanded by applying an upward axial force to the expansion cone 2635. In a preferred embodiment, once the slip joint 2640 is fully extended, the end plate 2645 is then axially displaced in the upward direction. In this manner, the end plate 2645 follows the expansion cone 2635. In a preferred embodiment, the chamber 2650 is  
20 pressurized when the frictional forces exceed a predetermined value. In this manner, the axial displacement of the expansion cone 2635 is provided by applying an axial force that is selectively supplemented by pressurizing the chamber 2650.

In an alternative embodiment, a compressible cement and/or epoxy is injected into the annular space between the unexpanded portion of the tubular  
25 member 2630 and the wellbore casing 2600 before and/or during the extrusion process. The compressible cement and/or epoxy is then preferably permitted to at least partially cure prior to the initiation of the radial expansion process. In this manner, an annular structural support and fluidic seal is provided around the tubular member 2630.

30 As illustrated in FIG. 26c, in a preferred embodiment, after the expandable tubular member 2630 has been completely extruded off of the expansion cone 2635, a new section of wellbore casing is formed that preferably includes the radially expanded tubular member 2630 and an outer annular layer of a fluidic sealing material. More generally, the apparatus 2620 is used to repair or form wellbore  
35 casings, pipelines, and structural supports.

Referring initially to FIG. 27, a preferred method 2700 of coupling an expandable tubular member to a preexisting structure includes the steps of: (1) coupling the expandable tubular member to the preexisting structure by axially displacing an expansion cone; and (2) radially expanding the expandable tubular by applying direct radial pressure.

In a preferred embodiment, as illustrated in FIG. 28, in step 2705, an expandable tubular member 2805 is coupled to a preexisting wellbore casing 2810 positioned within a subterranean formation 2815. In a preferred embodiment, the wellbore casing 2810 further includes an outer annular layer 2820 of a fluidic sealing material such as, for example, cement. The expandable tubular member 2805 may be coupled to the preexisting wellbore casing 2810 using any number of conventional commercially available methods for coupling an expandable tubular member to a preexisting structure such as, for example, pulling an expansion cone through a tubular member, or pushing an expansion cone through a tubular member using a pressurized fluidic material. In a preferred embodiment, the expandable tubular member 2805 is coupled to the preexisting structure 2810 using one or more of the apparatus and methods disclosed in the following: (1) U.S. utility patent application serial no. 09/454,139, attorney docket no. 25791.3.02, filed on 12/3/1999, which claimed the benefit of the filing date of U.S. provisional patent application no. 60/111,293, attorney docket no. 25791.3, filed on 12/7/1998; (2) U.S. utility patent application serial no. 09/510,913, attorney docket no. 25791.7.02, filed on 2/23/2000, which claimed the benefit of the filing date of U.S. provisional application no. 60/121,702, filed on 2/25/1999; (3) U.S. utility patent application serial no. 09/502,350, attorney docket no. 25791.8.02, filed on 2/10/2000, which claimed the benefit of the filing date of U.S. provisional application no. 60/119,611, attorney docket no. 25791.8; (4) U.S. utility patent application serial no. 09/440,338, attorney docket no. 25791.9.02, filed on 11/15/1999, which claimed the benefit of the filing date of U.S. provisional application no. 60/108,558, attorney docket no. 25791.9, filed on 11/16.1998; (5) U.S. provisional patent application no. 60/183,546, filed on 2/18/2000; (6) U.S. utility patent application no. 09/523,460, attorney docket no. 25791.11.02, filed on 3/10/2000, which claimed the benefit of the filing date of U.S. provisional application no. 60/124,042, filed on 3/11/1999; (7) U.S. utility patent application no. 09/512,895, attorney docket no. 25791.12.02, filed on 2/24/2000, which claimed the benefit of the filing dates of U.S. provisional application no. 60/121,841, attorney docket no. 25791.12, filed on 2/26/1999 and U.S. provisional

application no. 60/154,047, attorney docket no. 25791.29, filed on 9/16/1999; (8) U.S. utility application no. 09/511,941, attorney docket no. 25791.16.02, filed on 2/24/2000, which claimed the benefit of the filing date of U.S. provisional serial no. 60/121,907, attorney docket no. 25791.16, filed on 2/26/1999; (9) U.S. utility patent  
5 application no. 09/588,946, attorney docket no. 25791.17.02, filed on June 7, 2000, which claimed the benefit of the filing date of U.S. provisional patent application serial no. 60/137,998, attorney docket no. 25791.17, filed on 6/7/1999; (10) U.S. utility patent application no. 09/559,122, attorney docket no. 25791.23.02, filed on 4/26/2000, which claimed the benefit of the filing date of U.S. provisional application  
10 no. 60/131,106, attorney docket no. 25791.23, filed on 4/26/1999; (11) U.S. provisional application no. 60/146,203, attorney docket no. 25791.25, filed on 7/29/1999; (12) U.S. provisional application no. 60/143,039, attorney docket no. 25791.26, filed on 7/9/1999; (13) U.S. provisional patent application serial no. 60/162,671, attorney docket no. 25791.27, filed on 11/1/1999; (14) U.S. provisional  
15 application no. 60/159,039, attorney docket no. 25791.36, filed on 10/12,1999; (15) U.S. provisional patent application no. 60/159,033, attorney docket no. 25791.37, filed on 10/12/1999; and (16) U.S. provisional patent application no. 60/165,228, attorney docket no. 25791.39, filed on 11/12/1999, the disclosures of which are incorporated herein by reference. In a preferred embodiment, the amount of radial  
20 expansion provided in step 105 ranges from about 5% to 20%.

In a preferred embodiment, as illustrated in FIG. 29, in step 2710, at least a portion of the expandable tubular member 2805 is further radially expanded by using a radial expansion tool 2905 to apply direct radial pressure to the expandable tubular member 2805. The radial expansion tool 2905 may be any number of  
25 conventional radial expansion tools suitable for applying direct radial pressure to a tubular member. In a preferred embodiment, the radial expansion tool 2905 is provided substantially as disclosed on one or more of the following U.S. Patents: 5,014,779 and 5,083,608, the disclosures of which are incorporated herein by reference. In a preferred embodiment, the amount of radial expansion of the  
30 expandable tubular member 2805 provided in step 2710 ranges up to about 5%. In a preferred embodiment, the radial contact pressures generated by the radial expansion tool 2905 in step 2710 range from about 5,000 to 140,000 psi. in order to optimally plastically deform the expandable tubular member 205 to the final desired geometry.

In a preferred embodiment, the radial expansion provided in step 2705 is limited to the portion of the expandable tubular member 2805 that overlaps with the preexisting wellbore casing 2810. In this manner, the high compressive forces typically required to radially expand the portion of the expandable tubular member 2805 that overlaps with the preexisting wellbore casing 2810 are optimally provided.

In an alternative embodiment, the radial expansion in step 2705 radially expands the expandable tubular member 2805 to provide an inside diameter substantially equal to the inside diameter of the pre-existing wellbore casing 2810. In this manner, a mono-diameter wellbore casing is optimally provided.

Thus, the method 2700 provides a 2-step radial expansion process that utilizes: (1) a relatively quick method of radial expansion for the majority of the radial expansion; and (2) a high contact pressure method for the remaining radial expansion. In several alternative embodiments, the method 2700 is used to form or repair wellbore casings, pipelines, or structural supports.

The method 2700 further provides an apparatus and method for coupling an expandable tubular member to a preexisting structure. The expandable tubular is initially coupled to the preexisting structure by axially displacing an expansion cone within the expandable tubular member. The expandable tubular member is then further radially expanded by applying a radial force to the expandable tubular. The apparatus and method have wide application to the formation and repair of wellbore casings, pipelines, and structural supports. The apparatus and method provide an efficient and reliable method for forming and repairing wellbore casings, pipelines, and structural supports. In a preferred implementation, the initial radial expansion of the expandable tubular member by axially displacing the expansion cone provide from about 5% to 25% of radial expansion, and the subsequent application of direct radial pressure to the expandable tubular member provides an additional radial expansion of up to about 10%. In this manner, the desired final geometry of the radially expanded tubular member is optimally achieved in a time efficient and reliable manner. This method and apparatus is particularly useful in optimally creating profiles and seal geometries for liner tops and for connections between jointed tubulars.

A method of coupling an expandable tubular member to a preexisting structure has been described that includes positioning the tubular member and an expansion cone within the preexisting structure, anchoring the tubular member to the preexisting structure, axially displacing the expansion cone relative to the tubular

member by pulling the expansion cone through the tubular member, and lubricating the interface between the expansion cone and the tubular member. In a preferred embodiment, lubricating the interface between the expansion cone and the tubular member includes: injecting a lubricating fluid into the trailing edge of the interface  
5 between the expansion cone and the tubular member. In a preferred embodiment, the lubricating fluid has a viscosity ranging from about 1 to 10,000 centipoise. In a preferred embodiment, the injecting includes: injecting lubricating fluid into a tapered end of the expansion cone. In a preferred embodiment, the injecting includes: injecting lubricating fluid into the area around the axial midpoint of a first tapered end  
10 of the expansion cone. In a preferred embodiment, the injecting includes: injecting lubricating fluid into a second end of the expansion cone. In a preferred embodiment, the injecting includes: injecting lubricating fluid into a tapered first end and a second end of the expansion cone. In a preferred embodiment, the injecting includes: injecting lubricating fluid into an interior of the expansion cone. In a  
15 preferred embodiment, the injecting includes: injecting lubricating fluid through an outer surface of the expansion cone. In a preferred embodiment, the injecting includes: injecting the lubricating fluid into a plurality of discrete locations along the trailing edge portion. In a preferred embodiment, the lubricating fluid includes drilling mud. In a preferred embodiment, the lubricating fluid further includes:  
20 TorqTrim III, EP Mudlib, and DrillN-Slid. In a preferred embodiment, the lubricating fluid includes TorqTrim III, EP Mudlib, and Drill-N-Slid. In a preferred embodiment, the interface between the expansion cone and the tubular member includes: coating the interior surface of the tubular member with a lubricant. In a preferred embodiment, lubricating the interface between the expansion cone and the tubular  
25 member includes: coating the interior surface of the tubular member with a first part of a lubricant, and applying a second part of the lubricant to the interior surface of the tubular member. In a preferred embodiment, the lubricant comprises a metallic soap. In a preferred embodiment, the lubricant is selected from the group consisting of C-Lube-10, C-PHOS-58-M, and C-PHOS-58-R. In a preferred embodiment, the  
30 lubricant provides a sliding friction coefficient of less than about 0.20. In a preferred embodiment, the lubricant is chemically bonded to the interior surfaces of the tubular members. In a preferred embodiment, the lubricant is mechanically bonded to the interior surfaces of the tubular members. In a preferred embodiment, the lubricant is adhesively bonded to the interior surface of the tubular members. In a preferred

embodiment, the lubricant includes epoxy, molybdenum disulfide, graphite, aluminum, copper, aluminosilicate and polyethylenepolyamine.

5 A method of coupling a tubular member to a preexisting structure has also been described that includes positioning the tubular member and an expansion cone within the preexisting structure, anchoring the tubular member to the preexisting structure, and axially displacing the expansion cone relative to the tubular member by pulling the expansion cone through the tubular member. The tubular member preferably includes: an annular member, including: a wall thickness that varies less than about 8 %, a hoop yield strength that varies less than about 10 %, 10 imperfections of less than about 8 % of the wall thickness, no failure for radial expansions of up to about 30 %, and no necking of the walls of the annular member for radial expansions of up to about 25%.

15 A method of coupling a tubular member to a preexisting structure has also been described that includes injecting a lubricating fluid into the preexisting structure, positioning the tubular member and an expansion cone within the preexisting structure, anchoring the tubular member to the preexisting structure, and axially displacing the expansion cone relative to the tubular member by pulling the expansion cone through the tubular member. In a preferred embodiment, the lubricating fluid includes: BARO-LUB GOLD-SEAL™ brand drilling mud lubricant.

20 A method of coupling an expandable tubular member to a preexisting structure has also been described that includes positioning the expandable tubular member and an expansion cone within the preexisting structure, anchoring the expandable tubular member to the preexisting structure, and axially displacing the expansion cone relative to the expandable tubular member by 25 pulling the expansion cone through the expandable tubular member. In a preferred embodiment, the expandable tubular member includes: a first tubular member, a second tubular member, and a threaded connection for coupling the first tubular member to the second tubular member. In a preferred embodiment, the threaded connection includes: one or more sealing members for sealing the interface between 30 the first and second tubular members. In a preferred embodiment, the threaded connection comprises a pin and box threaded connection. In a preferred embodiment, the sealing members are positioned adjacent to an end portion of the threaded connection. In a preferred embodiment, one of the sealing members is positioned adjacent to an end portion of the threaded connection; and wherein 35 another one of the sealing members is not positioned adjacent to an end portion of

the threaded connection. In a preferred embodiment, a plurality of the sealing members are positioned adjacent to an end portion of the threaded connection.

A method of coupling an expandable tubular member to a preexisting structure has also been described that includes positioning the expandable tubular member and an expansion cone within the preexisting structure, anchoring the  
5 expandable tubular member to the preexisting structure, and axially displacing the expansion cone relative to the expandable tubular member by pulling the expansion cone through the expandable tubular member. In a preferred embodiment, the expandable tubular member includes a plurality of tubular  
10 members having threaded portions that are coupled to one another by the process of: coating the threaded portions of the tubular members with a sealant, coupling the threaded portions of the tubular members, and curing the sealant. In a preferred embodiment, the sealant is selected from the group consisting of epoxies, thermosetting sealing compounds, curable sealing compounds, and sealing  
15 compounds having polymerizable materials. In a preferred embodiment, the method further includes: initially curing the sealant prior to radially expanding the tubular members, and finally curing the sealant after radially expanding the tubular members. In a preferred embodiment, the sealant can be stretched up to about 30 to 40 percent after curing without failure. In a preferred embodiment, the sealant is  
20 resistant to conventional wellbore fluidic materials. In a preferred embodiment, the material properties of the sealant are substantially stable for temperatures ranging from about 0 to 450 °F. In a preferred embodiment, the method further includes: applying a primer to the threaded portions of the tubular members prior to coating the threaded portions of the tubular members with the sealant. In a preferred  
25 embodiment, the primer includes a curing catalyst. In a preferred embodiment, the primer is applied to the threaded portion of one of the tubular members and the sealant is applied to the threaded portion of the other one of the tubular members. In a preferred embodiment, the primer includes a curing catalyst.

A method of coupling a tubular member to a preexisting structure has also  
30 been described that includes positioning the tubular member and an expansion cone within the preexisting structure, anchoring the tubular member to the preexisting structure, and axially displacing the expansion cone relative to the tubular member by pulling the expansion cone through the expandable tubular member. In a preferred embodiment, the tubular member includes: a pair of rings for engaging the



preexisting structure, and a sealing element positioned between the rings for sealing the interface between the tubular member and the preexisting structure.

A method of coupling a tubular member to a preexisting structure has also been described that includes positioning the expandable tubular member and an expansion cone within the preexisting structure, anchoring the expandable tubular member to the preexisting structure, and axially displacing the expansion cone relative to the expandable tubular member by pulling the expansion cone through the expandable tubular member. In a preferred embodiment, the tubular member includes one or more slots. In a preferred embodiment, the slots are provided at a preexpanded portion of the tubular member. In a preferred embodiment, the slots are provided at a non-preexpanded portion of the tubular member.

A method of coupling a tubular member to a preexisting structure has also been described that includes positioning the expandable tubular member and an expansion cone within the preexisting structure, anchoring the expandable tubular member to the preexisting structure, and axially displacing the expansion cone relative to the expandable tubular member by pulling the expansion cone through the expandable tubular member. In a preferred embodiment, the tubular member includes: a first preexpanded portion, an intermediate portion coupled to the first preexpanded portion including a sealing element, and a second preexpanded portion coupled to the intermediate portion.

A method of coupling a tubular member to a preexisting structure has also been described that includes positioning the expandable tubular member and an expansion cone within the preexisting structure, anchoring the expandable tubular member to the preexisting structure, and axially displacing the expansion cone relative to the expandable tubular member by pulling the expansion cone through the expandable tubular member by applying an axial force to the expansion cone. The axial force preferably includes a substantially constant axial force, and an increased axial force. In a preferred embodiment, the increased axial force is provided on a periodic basis. In a preferred embodiment, the increased axial force is provided on a random basis. In a preferred embodiment, the ratio of the increased axial force to the substantially constant axial force ranges from about 5 to 40 %.

A method of coupling a tubular member to a preexisting structure has also been described that includes positioning the tubular member and an expansion cone within the preexisting structure, anchoring the tubular member to the preexisting

structure, and axially displacing the expansion cone relative to the expandable tubular member by pushing and pulling the expansion cone through the expandable tubular member. In a preferred embodiment, pushing the expansion cone includes: injecting a pressurized fluidic material into contact with the expansion cone.

5           A method of coupling a tubular member to a preexisting structure has also been described that includes positioning the tubular member and an expansion cone within the preexisting structure, anchoring the tubular member to the preexisting structure, axially displacing the expansion cone relative to the tubular member by pulling the expansion cone through the expandable tubular member, and injecting a  
10   curable fluidic sealing material between the tubular member and the preexisting structure prior to axially displacing the expansion cone.

          A method of coupling a tubular member to a preexisting structure has also been described that includes positioning the tubular member and an expansion cone within the preexisting structure, anchoring the tubular member to the preexisting  
15   structure by increasing the size of the expansion cone, and axially displacing the expansion cone relative to the tubular member by pulling the expansion cone through the tubular member.

          A method of coupling a tubular member to a preexisting structure has also been described that includes positioning the tubular member and an expansion cone within the preexisting structure, anchoring the tubular member to the preexisting  
20   structure by heating a portion of the tubular member, and axially displacing the expansion cone relative to the tubular member by pulling the expansion cone through the tubular member.

          A method of coupling an expandable tubular member to a preexisting  
25   structure has also been described that includes positioning the expandable tubular member, an expansion cone, and an anchoring device within the preexisting structure, positioning the anchoring device above the expansion cone, anchoring the expandable tubular member to the preexisting structure using the anchoring device, and axially displacing the expansion cone.

30           A method of coupling an expandable tubular member to a preexisting structure has also been described that includes positioning the tubular member and an expansion cone within the preexisting structure, explosively anchoring the tubular member to the preexisting structure, and axially displacing the expansion cone relative to the tubular member.

A method of coupling an expandable tubular to a preexisting structure has also been described that includes fixing the position of an expansion cone within the preexisting structure, driving the expandable tubular member onto the expansion cone in a first direction, and axially displacing the expansion cone in a second  
5 direction relative to the expandable tubular member. In a preferred embodiment, the first and second directions are different.

A method of coupling an expandable tubular member to a preexisting structure has also been described that includes placing the expandable tubular, an expansion cone, and a resilient anchor within the preexisting structure, releasing the  
10 resilient anchor, and axially displacing the expansion cone within the expandable tubular member.

A method of coupling an expandable tubular member to a preexisting structure has also been described that includes placing the expandable tubular member, an expansion cone, and an anchor into the preexisting structure, anchoring  
15 the expandable tubular member to the preexisting structure by: pivoting one or more engagement elements, and axially displacing the expansion cone. In a preferred embodiment, pivoting the engagement elements includes: actuating the engagement elements. In a preferred embodiment, pivoting the engagement elements includes: placing a quantity of a fluidic material onto the engagement  
20 elements. In a preferred embodiment, pivoting the engagement elements includes: displacing the expandable tubular member.

A method of coupling an expandable tubular member to a preexisting structure has also been described that includes placing the expandable tubular member and an expansion cone into the preexisting structure, placing a quantity of  
25 a fluidic material onto the expandable tubular member to anchor the expandable tubular member to the preexisting structure, and axially displacing the expansion cone. In a preferred embodiment, the fluidic material comprises a barite plug. In a preferred embodiment, the fluidic material comprises a flex plug.

A method of coupling an expandable tubular member to a preexisting  
30 structure has also been described that includes positioning the expandable tubular member and an expansion cone into the preexisting structure, anchoring the expandable tubular member to the preexisting structure by injecting a quantity of a hardenable fluidic material into the preexisting structure, at least partially curing the hardenable fluidic sealing material, and  
35 axially displacing the expansion cone.

A method of coupling an expandable tubular member to a preexisting structure has also been described that includes placing the expandable tubular member and an expansion cone within the preexisting structure, and applying an axial force to the expandable tubular member in a downward direction.

5 A method of coupling an expandable tubular member to a preexisting structure has also been described that includes placing the expandable tubular member and an expansion cone within the preexisting structure, injecting a quantity of a first fluidic material having a first density into the region of the preexisting structure outside of the expandable tubular member, and injecting a quantity of a  
10 second fluidic material having a second density into a portion of the expandable tubular member below the expansion cone. In a preferred embodiment, the second density is greater than the first density.

A method of coupling an expandable tubular member to a preexisting structure has also been described that includes placing the expandable tubular  
15 member and an expansion cone into the preexisting structure, anchoring the expandable tubular member to the preexisting structure, applying an axial force to the expansion cone, and pressurizing an interior portion of the expandable tubular member below the expansion cone.

A method of coupling an expandable tubular member to a preexisting  
20 structure has also been described that includes placing the expandable tubular member and an expansion cone into the preexisting structure, and applying an axial force to the expandable tubular member.

An apparatus for coupling a tubular member to a preexisting structure has also been described that includes an expandable tubular member, an anchoring  
25 device adapted to couple the expandable tubular member to the preexisting structure, and an expansion cone movably coupled to the expandable tubular member and adapted to radially expand the expandable tubular member, including: a housing including a tapered first end and a second end, one or more grooves formed in the outer surface of the tapered first end, and one or more axial flow  
30 passages fluidically coupled to the grooves. In a preferred embodiment, the grooves include circumferential grooves. In a preferred embodiment, the grooves include spiral grooves. In a preferred embodiment, the grooves are concentrated around the axial midpoint of the tapered portion of the housing. In a preferred embodiment, the axial flow passages include axial grooves. In a preferred embodiment, the axial  
35 grooves are spaced apart by at least about 3 inches in the circumferential direction.

In a preferred embodiment, the axial grooves extend from the tapered first end of the body to the grooves. In a preferred embodiment, the axial grooves extend from the second end of the body to the grooves. In a preferred embodiment, the axial grooves extend from the tapered first end of the body to the second end of the body.

5 In a preferred embodiment, the axial flow passages are positioned within the housing of the expansion cone. In a preferred embodiment, the axial flow passages extend from the tapered first end of the body to the grooves. In a preferred embodiment, the axial flow passages extend from the tapered first end of the body to the second end of the body. In a preferred embodiment, the axial flow passages

10 extend from the second end of the body to the grooves. In a preferred embodiment, one or more of the flow passages include inserts having restricted flow passages. In a preferred embodiment, one or more of the axial flow passages include filters. In a preferred embodiment, the cross sectional area of the grooves is greater than the cross sectional area of the axial flow passages. In a preferred embodiment, the

15 cross-sectional area of the grooves ranges from about  $2 \times 10^{-4} \text{ in}^2$  to  $5 \times 10^{-2} \text{ in}^2$ . In a preferred embodiment, the cross-sectional area of the axial flow passages ranges from about  $2 \times 10^{-4} \text{ in}^2$  to  $5 \times 10^{-2} \text{ in}^2$ . In a preferred embodiment, the angle of attack of the first tapered end of the body ranges from about 10 to 30 degrees. In a preferred embodiment, the grooves are concentrated in a trailing edge portion of the

20 tapered first end. In a preferred embodiment, the angle of inclination of the axial flow passages relative to the longitudinal axis of the expansion cone is greater than the angle of attack of the first tapered end. In a preferred embodiment, the grooves include: a flow channel having a first radius of curvature, a first shoulder positioned on one side of the flow channel having a second radius of curvature, and a second

25 shoulder positioned on the other side of the flow channel having a third radius of curvature. In a preferred embodiment, the first, second and third radii of curvature are substantially equal. In a preferred embodiment, the axial flow passages include: a flow channel having a first radius of curvature, a first shoulder positioned on one side of the flow channel having a second radius of curvature, and a second shoulder

30 positioned on the other side of the flow channel having a third radius of curvature. In a preferred embodiment, the first, second and third radii of curvature are substantially equal. In a preferred embodiment, the second radius of curvature is greater than the third radius of curvature.

An apparatus for coupling an expandable tubular member to a preexisting

35 structure has also been described that includes an expandable tubular member, an

anchoring device adapted to couple the expandable tubular member to the preexisting structure, and an expansion cone movably coupled to the expandable tubular member and adapted to radially expand the expandable tubular member. In a preferred embodiment, the expandable tubular member includes: an annular member, having: a wall thickness that varies less than about 8 %, a hoop yield strength that varies less than about 10 %; imperfections of less than about 8 % of the wall thickness, no failure for radial expansions of up to about 30 %, and no necking of the walls of the annular member for radial expansions of up to about 25%.

10 An apparatus for coupling an expandable tubular member to a preexisting structure has also been described that includes an expandable tubular member, an anchoring device adapted to couple the expandable tubular member to the preexisting structure, and an expansion cone movably coupled to the expandable tubular member and adapted to radially expand the expandable tubular member. In a preferred embodiment, the expandable tubular member includes: a first tubular member, a second tubular member, and a threaded connection for coupling the first tubular member to the second tubular member. In a preferred embodiment, the threaded connection includes: one or more sealing members for sealing the interface between the first and second tubular members. In a preferred embodiment, the threaded connection comprises a pin and box threaded connection. In a preferred embodiment, the sealing members are positioned adjacent to an end portion of the threaded connection. In a preferred embodiment, one of the sealing members is positioned adjacent to an end portion of the threaded connection, and another one of the sealing members is not positioned adjacent to an end portion of the threaded connection. In a preferred embodiment, the plurality of the sealing members are positioned adjacent to an end portion of the threaded connection.

20 An apparatus for coupling an expandable tubular member to a preexisting structure has also been described that includes an expandable tubular member, an anchoring device adapted to couple the expandable tubular member to the preexisting structure, and an expansion cone movably coupled to the expandable tubular member and adapted to radially expand the expandable tubular member. In a preferred embodiment, the expandable tubular member includes: a layer of a lubricant coupled to the interior surface of the tubular member. In a preferred embodiment, the lubricant comprises a metallic soap. In a preferred embodiment,

the lubricant is selected from the group consisting of C-Lube-10, C-PHOS-58-M, and C-PHOS-58-R. In a preferred embodiment, the lubricant provides a sliding friction coefficient of less than about 0.20. In a preferred embodiment, the lubricant is chemically bonded to the interior surface of the expandable tubular member. In a preferred embodiment, the lubricant is mechanically bonded to the interior surface of the expandable tubular member. In a preferred embodiment, the lubricant is adhesively bonded to the interior surface of the expandable tubular member. In a preferred embodiment, the lubricant includes epoxy, molybdenum disulfide, graphite, aluminum, copper, aluminosilicate and polyethylenepolyamine.

10 An apparatus for coupling an expandable tubular member to a preexisting structure has also been described that includes an expandable tubular member, an anchoring device adapted to couple the expandable tubular member to the preexisting structure, and an expansion cone movably coupled to the expandable tubular member and adapted to radially expand the expandable tubular member. In a preferred embodiment, the expandable tubular member includes: a pair of tubular members having threaded portions coupled to one another, and a quantity of a sealant within the threaded portions of the tubular members. In a preferred embodiment, the sealant is selected from the group consisting of epoxies, thermosetting sealing compounds, curable sealing compounds, and sealing compounds having polymerizable materials. In a preferred embodiment, the sealant includes an initial cure cycle and a final cure cycle. In a preferred embodiment, the sealant can be stretched up to about 30 to 40 percent without failure. In a preferred embodiment, the sealant is resistant to conventional wellbore fluidic materials. In a preferred embodiment, the material properties of the sealant are substantially stable for temperatures ranging from about 0 to 450 °F. In a preferred embodiment, the threaded portions of the tubular members include a primer for improving the adhesion of the sealant to the threaded portions.

30 An apparatus for coupling an expandable tubular member to a preexisting structure has also been described that includes an expandable tubular member, an anchoring device adapted to couple the expandable tubular member to the preexisting structure, and an expansion cone movably coupled to the expandable tubular member and adapted to radially expand the expandable tubular member. In a preferred embodiment, the expandable tubular member includes: a pair of rings for engaging the preexisting structure, and a sealing element positioned between the

rings for sealing the interface between the tubular member and the preexisting structure.

An apparatus for coupling an expandable tubular member to a preexisting structure has also been described that includes an expandable tubular member, an  
5 anchoring device adapted to couple the expandable tubular member to the preexisting structure, and an expansion cone movably coupled to the expandable tubular member and adapted to radially expand the expandable tubular member. In a preferred embodiment, the expandable tubular member includes one or more slots. In a preferred embodiment, the slots are provided at a preexpanded portion of  
10 the expandable tubular member. In a preferred embodiment, the slots are provided at a non-preexpanded portion of the tubular member.

An apparatus for coupling an expandable tubular member to a preexisting structure has also been described that includes an expandable tubular member, an  
15 anchoring device adapted to couple the expandable tubular member to the preexisting structure, and an expansion cone movably coupled to the expandable tubular member and adapted to radially expand the expandable tubular member. In a preferred embodiment, the expandable tubular member includes: a first preexpanded portion, an intermediate portion coupled to the first preexpanded portion including a sealing element, and a second preexpanded portion coupled to  
20 the intermediate portion.

An apparatus for coupling an expandable tubular member to a preexisting structure has also been described that includes an expandable tubular member, an  
anchoring device adapted to couple the expandable tubular member to the preexisting structure, an expansion cone movably coupled to the expandable tubular  
25 member and adapted to radially expand the expandable tubular member, and a valveable fluid passage coupled to the anchoring device.

An apparatus for coupling an expandable tubular member to a preexisting structure has also been described that includes a first support member, a second support member coupled to the first support member, an expansion cone coupled to  
30 the first support member, an expandable tubular member coupled to the expansion cone, and an anchoring device coupled to the second support member adapted to couple the expandable tubular member to the preexisting structure. In a preferred embodiment, the anchoring device is positioned above the expansion cone. In a preferred embodiment, the outside diameter of the expansion cone is greater than  
35 the inside diameter of the expandable tubular member. In a preferred embodiment,



the outside diameter of the expansion cone is approximately equal to the outside diameter of the expandable tubular member.

5 An apparatus for coupling an expandable tubular member to a preexisting structure has also been described that includes a first support member, a second support member coupled to the first support member, an expansion cone coupled to the first support member, an expandable tubular member coupled to the expansion cone, and an explosive anchoring device coupled to the second support member adapted to couple the expandable tubular member to the preexisting structure.

10 An apparatus for coupling an expandable tubular member to a preexisting structure has also been described that includes a support member, an expandable expansion cone coupled to the support member, and an expandable tubular member coupled to the expansion cone.

15 An apparatus for coupling an expandable tubular member to a preexisting structure has also been described that includes a support member, an expandable expansion cone coupled to the support member, and an expandable tubular member coupled to the expandable expansion cone. In a preferred embodiment, the expandable tubular member includes one or more anchoring devices. In a preferred embodiment, the expandable tubular member includes a slotted end portion.

20 An apparatus for coupling an expandable tubular to a preexisting structure has also been described that includes a support member, an expansion cone coupled to the support member, an expandable tubular member coupled to the expansion cone including one or more shape memory metal inserts, and a heater coupled to the support member in opposing relation to the shape memory metal inserts.

25 An apparatus for coupling an expandable tubular member to a preexisting structure has also been described that includes a support member, an expansion cone coupled to the support member, an expandable tubular member coupled to the expandable expansion cone, and a resilient anchor coupled to the expandable tubular member. In a preferred embodiment, the resilient anchor includes a resilient scroll. In a preferred embodiment, the resilient anchor includes one or more resilient arms. In a preferred embodiment, the resilient anchor includes: one or more resilient radially oriented elements. In a preferred embodiment, the resilient anchor is adapted to mate with the expansion cone.

30

An expandable tubular member has also been described that includes an expandable tubular body, one or more resilient panels coupled to the expandable tubular body, and a release member releasably coupled to the resilient panels adapted to controllably release the resilient panels.

5 An apparatus for coupling an expandable tubular member to a preexisting structure has also been described that includes a support member, an expansion cone coupled to the support member, an expandable tubular member coupled to the expandable expansion cone, and an anchor coupled to the expandable tubular member, including: one or more spikes pivotally coupled to the  
10 expandable tubular member for engaging the preexisting structure. In a preferred embodiment, the apparatus further includes one or more corresponding actuators for pivoting the spikes.

An apparatus for coupling an expandable tubular member to a preexisting structure has also been described that includes a support member,  
15 an expansion cone coupled to the support member, an expandable tubular member coupled to the expandable expansion cone, and an anchor coupled to the expandable tubular member, including: one or more petal baskets pivotally coupled to the expandable tubular member. In a preferred embodiment, the apparatus further includes one or more corresponding actuators for pivoting the petal baskets.

20 An apparatus for coupling an expandable tubular member to a preexisting structure has also been described that includes a support member, an expansion cone coupled to the support member, an expandable tubular member coupled to the expansion cone, including: a slotted portion provided at one end of the expandable tubular member.

25 An apparatus for coupling an expandable tubular member to a preexisting structure has also been described that includes a support member, an expansion cone, an expandable tubular member coupled to the expansion cone, a coupling device coupled to the support member and an end portion of the expandable tubular member, and a mass coupled to the end portion of the expandable tubular member.  
30 In a preferred embodiment, the weight of the mass is greater than about 50 to 100 % of the yield strength of the expandable tubular member.

An apparatus for coupling an expandable tubular member to a preexisting structure has also been described that includes a support member including a fluid passage, an expansion cone coupled to the support member, an expandable tubular  
35 member coupled to the expansion cone, a slip joint coupled to the expansion cone,

an end plate coupled to the slip joint, a fluid chamber coupled to the fluid passage, the fluid chamber defined by the interior portion of the expandable tubular member between the expansion cone and the end plate.

5 A method of coupling a tubular member to a preexisting structure has been described that includes positioning the tubular member and an expansion cone within the preexisting structure, axially displacing the expansion cone, removing the expansion cone, and applying direct radial pressure to the first tubular member. In a preferred embodiment, axially displacing the expansion cone includes pressurizing at least a portion of the interior of the tubular member. In a preferred embodiment, axially displacing the expansion cone includes: injecting a fluidic material into the tubular member. In a preferred embodiment, axially displacing the expansion cone includes: applying a tensile force to the expansion cone. In a preferred embodiment, axially displacing the expansion cone includes: displacing the expansion cone into the tubular member. In a preferred embodiment, axially displacing the expansion cone includes: displacing the expansion cone out of the tubular member. In a preferred embodiment, axially displacing the expansion cone radially expands the tubular member by about 10% to 20%. In a preferred embodiment, applying direct radial pressure to the first tubular member radially expands the tubular member by up to about 5%. In a preferred embodiment, applying direct radial pressure to the tubular member includes applying a radial force at discrete locations. In a preferred embodiment, the preexisting structure includes a wellbore casing. In a preferred embodiment, the preexisting structure includes a pipeline. In a preferred embodiment, the preexisting structure includes a structural support.

25 An apparatus also has been described that includes a tubular member coupled to a preexisting structure. The tubular member is coupled to the preexisting structure by the process of: positioning the tubular member and an expansion cone within the preexisting structure, axially displacing the expansion cone, removing the expansion cone, and applying direct radial pressure to the tubular member. In a preferred embodiment, axially displacing the expansion cone includes: pressurizing at least a portion of the interior of the tubular member. In a preferred embodiment, axially displacing the expansion cone includes: injecting a fluidic material into the tubular member. In a preferred embodiment, axially displacing the expansion cone includes: applying a tensile force to the expansion cone. In a preferred embodiment, axially displacing the expansion cone includes: displacing the

---

expansion cone into the tubular member. In a preferred embodiment, axially displacing the expansion cone includes: displacing the expansion cone out of the tubular member. In a preferred embodiment, axially displacing the expansion cone radially expands the tubular member by about 10% to 20%. In a preferred  
5 embodiment, applying direct radial pressure to the tubular member radially expands the tubular member by up to about 5%. In a preferred embodiment, applying direct radial pressure to the tubular member includes applying a radial force at discrete locations. In a preferred embodiment, the preexisting structure includes a wellbore casing. In a preferred embodiment, the preexisting structure includes a pipeline. In  
10 a preferred embodiment, the preexisting structure includes a structural support.

Although this detailed description has shown and described illustrative embodiments of the invention, this description contemplates a wide range of modifications, changes, and substitutions. In some instances, one may employ some features of the present invention without a corresponding use of the other  
15 features. Accordingly, it is appropriate that readers should construe the appended claims broadly, and in a manner consistent with the scope of the invention.

## **CLAIMS**

1. A system for coupling an expandable tubular member to a preexisting structure, comprising:
  - 5 means for positioning the tubular member and an expansion cone within the preexisting structure;
  - means for anchoring the tubular member to the preexisting structure;
  - means for axially displacing the expansion cone relative to the tubular member by pulling the expansion cone through the tubular member; and
  - 10 means for lubricating an interface between the tubular member and the expansion cone with a lubricant.
  
2. The system of claim 1, wherein the means for lubricating the interface between the expansion cone and the tubular member includes:
  - 15 means for coating the interior surface of the tubular member with a first part of a lubricant; and
  - means for applying a second part of the lubricant to the interior surface of the tubular member.
  
- 20 3. The system of claim 1, wherein the lubricant comprises a metallic soap.
  
4. The system of claim 1, wherein the lubricant is selected from the group consisting of C-Lube-10, C-PHOS-58-M, and C-PHOS-58-R.
  
- 25 5. The system of claim 1, wherein the lubricant provides a sliding friction coefficient of less than 0.20.
  
6. The system of claim 1, wherein the lubricant is chemically bonded to the interior surfaces of the tubular member.
  
- 30 7. The system of claim 1, wherein the lubricant is mechanically bonded to the interior surfaces of the tubular member.
  
8. The system of claim 1, wherein the lubricant is adhesively bonded to the interior surface of the tubular member.
  
- 35

9. The system of claim 1, wherein the lubricant includes epoxy, molybdenum disulfide, graphite, aluminum, copper, aluminosilicate and polyethylenepolyamine.
- 5 10. The system of claim 1, wherein the expandable tubular member includes:  
a first tubular member;  
a second tubular member; and  
a pin and box threaded connection for coupling the first tubular member to  
the second tubular member, the threaded connection including:  
10 one or more sealing members for sealing the interface between the first and  
second tubular members.
11. The system of claim 10, wherein the sealing members are positioned  
adjacent to an end portion of the threaded connection.
- 15 12. The system of claim 10, wherein one of the sealing members is positioned  
adjacent to an end portion of the threaded connection; and wherein another one of  
the sealing members is not positioned adjacent to an end portion of the threaded  
connection.
- 20 13. The system of claim 10, wherein a plurality of the sealing members are  
positioned adjacent to an end portion of the threaded connection.
14. The system of claim 1, wherein the expandable tubular member includes:  
25 a plurality of tubular members having threaded portions that are coupled to  
one another by the process of:  
coating the threaded portions of the tubular members with a sealant;  
coupling the threaded portions of the tubular members; and  
curing the sealant.
- 30 15. The system of claim 14, wherein the sealant is selected from the group  
consisting of epoxies, thermosetting sealing compounds, curable sealing  
compounds, and sealing compounds having polymerizable materials.
- 35 16. The system of claim 14, further including:

means for initially curing the sealant prior to radially expanding the tubular members; and

means for finally curing the sealant after radially expanding the tubular members.

5

17. The system of claim 14, wherein the sealant can be stretched up to 40 percent after curing without failure.

18. The system of claim 14, wherein the sealant is resistant to conventional wellbore fluidic materials.

19. The system of claim 14, wherein the material properties of the sealant are substantially stable for temperatures ranging from 0 to 450°F.

20. The system of claim 14, further including:  
means for applying a primer to the threaded portions of the tubular members prior to coating the threaded portions of the tubular members with the sealant.

21. The system of claim 20, wherein the primer includes a curing catalyst.

20

22. The system of claim 20, wherein the primer is applied to the threaded portion of one of the tubular members and the sealant is applied to the threaded portion of the other one of the tubular members.

23. The system of claim 20, wherein the primer includes a curing catalyst.

24. The system of claim 1, wherein the expandable tubular member includes:  
a pair of rings for engaging the preexisting structure; and  
a sealing element positioned between the rings for sealing the interface between the tubular member and the preexisting structure.

30

25. The system of claim 1, wherein the expandable tubular member includes:  
a first preexpanded portion;  
an intermediate portion coupled to the first preexpanded portion including a sealing element; and

35

a second preexpanded portion coupled to the intermediate portion.

26. The system of claim 1, wherein the means for anchoring comprises a means for explosively anchoring the tubular member to the preexisting structure.

5



1. A method of coupling an expandable tubular member to a preexisting structure, comprising:
  - 5 positioning the tubular member and an expansion cone within the preexisting structure;
  - anchoring the tubular member to the preexisting structure;
  - axially displacing the expansion cone relative to the tubular member by pulling the expansion cone through the tubular member; and
  - 10 lubricating the interface between the expansion cone and the tubular member.
  
2. The method of claim 1, wherein lubricating the interface between the expansion cone and the tubular member includes:
  - 15 injecting a lubricating fluid into the trailing edge of the interface between the expansion cone and the tubular member.
  
3. The method of claim 2, wherein the lubricating fluid has a viscosity ranging from about 1 to 10,000 centipoise.
  
- 20 4. The method of claim 2, wherein the injecting includes:
  - injecting lubricating fluid into a tapered end of the expansion cone.
  
5. The method of claim 2, wherein the injecting includes:
  - 25 injecting lubricating fluid into the area around the axial midpoint of a first tapered end of the expansion cone.
  
6. The method of claim 2, wherein the injecting includes:
  - injecting lubricating fluid into a second end of the expansion cone.
  
- 30 7. The method of claim 2, wherein the injecting includes:
  - injecting lubricating fluid into a tapered first end and a second end of the expansion cone.
  
8. The method of claim 2, wherein the injecting includes:
  - 35 injecting lubricating fluid into an interior of the expansion cone.

9. The method of claim 2, wherein the injecting includes:  
injecting lubricating fluid through an outer surface of the expansion cone.
- 5 10. The method of claim 2, wherein the injecting includes:  
injecting the lubricating fluid into a plurality of discrete locations along the  
trailing edge portion.
- 10 11. The method of claim 2, wherein the lubricating fluid comprises:  
drilling mud.
12. The method of claim 2, wherein the lubricating fluid further includes:  
TorqTrim III;  
EP Mudlib; and  
15 DrillN-Slid.
13. The method of claim 2, wherein the lubricating fluid comprises:  
TorqTrim III;  
EP Mudlib; and  
20 DrillN-Slid.
14. The method of claim 1, wherein lubricating the interface between the  
expansion cone and the tubular member includes:  
coating the interior surface of the tubular member with a lubricant.  
25
15. The method of claim 1, wherein lubricating the interface between the  
expansion cone and the tubular member includes:  
coating the interior surface of the tubular member with a first part of a  
lubricant; and  
30 applying a second part of the lubricant to the interior surface of the tubular  
member.
16. The method of claim 14, wherein the lubricant comprises a metallic soap.

17. The method of claim 14, wherein the lubricant is selected from the group consisting of C-Lube-10, C-PHOS-58-M, and C-PHOS-58-R.
18. The method of claim 14, wherein the lubricant provides a sliding friction coefficient of less than about 0.20.
19. The method of claim 14, wherein the lubricant is chemically bonded to the interior surfaces of the tubular members.
20. The method of claim 14, wherein the lubricant is mechanically bonded to the interior surfaces of the tubular members.
21. The method of claim 14, wherein the lubricant is adhesively bonded to the interior surface of the tubular members.
22. The method of claim 14, wherein the lubricant includes epoxy, molybdenum disulfide, graphite, aluminum, copper, aluminosilicate and polyethylenepolyamine.
23. A method of coupling a tubular member to a preexisting structure, comprising:  
positioning the tubular member and an expansion cone within the preexisting structure;  
anchoring the tubular member to the preexisting structure; and  
axially displacing the expansion cone relative to the tubular member by pulling the expansion cone through the tubular member;  
wherein the tubular member includes:  
an annular member, including:  
a wall thickness that varies less than about 8 %;  
a hoop yield strength that varies less than about 10 %;  
imperfections of less than about 8 % of the wall thickness;  
no failure for radial expansions of up to about 30 %; and  
no necking of the walls of the annular member for radial expansions of up to about 25%.

24. A method of coupling a tubular member to a preexisting structure, comprising:
- injecting a lubricating fluid into the preexisting structure;
  - positioning the tubular member and an expansion cone within the preexisting structure;
  - anchoring the tubular member to the preexisting structure; and
  - axially displacing the expansion cone relative to the tubular member by pulling the expansion cone through the tubular member.
25. The method of claim 24, wherein the lubricating fluid comprises: BARO-LUB GOLD-SEAL™ brand drilling mud lubricant.
26. A method of coupling an expandable tubular member to a preexisting structure, comprising:
- positioning the expandable tubular member and an expansion cone within the preexisting structure;
  - anchoring the expandable tubular member to the preexisting structure; and
  - axially displacing the expansion cone relative to the expandable tubular member by pulling the expansion cone through the expandable tubular member;
- wherein the expandable tubular member includes:
- a first tubular member;
  - a second tubular member; and
  - a threaded connection for coupling the first tubular member to the second tubular member, the threaded connection including:
- one or more sealing members for sealing the interface between the first and second tubular members.
27. The method of claim 26, wherein the threaded connection comprises a pin and box threaded connection.
28. The method of claim 26, wherein the sealing members are positioned adjacent to an end portion of the threaded connection.
29. The method of claim 26, wherein one of the sealing members is positioned adjacent to an end portion of the threaded connection; and wherein another one of

the sealing members is not positioned adjacent to an end portion of the threaded connection.

5 30. The method of claim 26, wherein a plurality of the sealing members are positioned adjacent to an end portion of the threaded connection.

31. A method of coupling an expandable tubular member to a preexisting structure, comprising:

10 positioning the expandable tubular member and an expansion cone within the preexisting structure;

anchoring the expandable tubular member to the preexisting structure; and axially displacing the expansion cone relative to the expandable tubular member by pulling the expansion cone through the expandable tubular member;

15 wherein the expandable tubular member includes a plurality of tubular members having threaded portions that are coupled to one another by the process

of: coating the threaded portions of the tubular members with a sealant; coupling the threaded portions of the tubular members; and curing the sealant.

20 32. The method of claim 31, wherein the sealant is selected from the group consisting of epoxies, thermosetting sealing compounds, curable sealing compounds, and sealing compounds having polymerizable materials.

33. The method of claim 31, further including:

25 initially curing the sealant prior to radially expanding the tubular members;

and

finally curing the sealant after radially expanding the tubular members.

34. The method of claim 31, wherein the sealant can be stretched up to about 30  
30 to 40 percent after curing without failure.

35. The method of claim 31, wherein the sealant is resistant to conventional wellbore fluidic materials.

36. The method of claim 31, wherein the material properties of the sealant are substantially stable for temperatures ranging from about 0 to 450 °F.
37. The method of claim 31, further including:  
5 applying a primer to the threaded portions of the tubular members prior to coating the threaded portions of the tubular members with the sealant.
38. The method of claim 37, wherein the primer includes a curing catalyst.
- 10 39. The method of claim 37, wherein the primer is applied to the threaded portion of one of the tubular members and the sealant is applied to the threaded portion of the other one of the tubular members.
40. The method of claim 37, wherein the primer includes a curing catalyst.  
15
41. A method of coupling a tubular member to a preexisting structure, comprising:  
positioning the tubular member and an expansion cone within the preexisting structure;  
20 anchoring the tubular member to the preexisting structure; and  
axially displacing the expansion cone relative to the tubular member by pulling the expansion cone through the expandable tubular member;  
wherein the tubular member includes:  
a pair of rings for engaging the preexisting structure; and  
25 a sealing element positioned between the rings for sealing the interface between the tubular member and the preexisting structure.
42. A method of coupling a tubular member to a preexisting structure, comprising:  
30 positioning the expandable tubular member and an expansion cone within the preexisting structure;  
anchoring the expandable tubular member to the preexisting structure; and  
axially displacing the expansion cone relative to the expandable tubular member by pulling the expansion cone through the expandable tubular member;  
35 wherein the tubular member includes one or more slots.

43. The method of claim 42, wherein the slots are provided at a preexpanded portion of the tubular member.

5 44. The method of claim 42, wherein the slots are provided at a non-preexpanded portion of the tubular member.

45. A method of coupling a tubular member to a preexisting structure, comprising:

10 positioning the expandable tubular member and an expansion cone within the preexisting structure;

anchoring the expandable tubular member to the preexisting structure; and

axially displacing the expansion cone relative to the expandable tubular

member by pulling the expansion cone through the expandable tubular member;

15 wherein the tubular member includes:

a first preexpanded portion;

an intermediate portion coupled to the first preexpanded portion including a sealing element; and

a second preexpanded portion coupled to the intermediate portion.

20

46. A method of coupling a tubular member to a preexisting structure, comprising:

positioning the expandable tubular member and an expansion cone within the preexisting structure;

25 anchoring the expandable tubular member to the preexisting structure; and

axially displacing the expansion cone relative to the expandable tubular

member by pulling the expansion cone through the expandable tubular member by applying an axial force to the expansion cone;

wherein the axial force includes:

30 a substantially constant axial force; and

an increased axial force.

47. The method of claim 46, wherein the increased axial force is provided on a periodic basis.

35

48. The method of claim 46, wherein the increased axial force is provided on a random basis.

49. The method of claim 46, wherein the ratio of the increased axial force to the substantially constant axial force ranges from about 5 to 40 %.

51. A method of coupling a tubular member to a preexisting structure, comprising:

positioning the tubular member and an expansion cone within the preexisting structure;

anchoring the tubular member to the preexisting structure; and

axially displacing the expansion cone relative to the expandable tubular member by pushing and pulling the expansion cone through the expandable tubular member.

52. The method of claim 51, wherein pushing the expansion cone includes: injecting a pressurized fluidic material into contact with the expansion cone.

53. A method of coupling a tubular member to a preexisting structure, comprising:

positioning the tubular member and an expansion cone within the preexisting structure;

anchoring the tubular member to the preexisting structure;

axially displacing the expansion cone relative to the tubular member by pulling the expansion cone through the expandable tubular member; and

injecting a curable fluidic sealing material between the tubular member and the preexisting structure prior to axially displacing the expansion cone.

54. A method of coupling a tubular member to a preexisting structure, comprising:

positioning the tubular member and an expansion cone within the preexisting structure;

anchoring the tubular member to the preexisting structure by increasing the size of the expansion cone; and



axially displacing the expansion cone relative to the tubular member by pulling the expansion cone through the tubular member.

55. A method of coupling a tubular member to a preexisting structure,  
5 comprising:

positioning the tubular member and an expansion cone within the preexisting structure;

anchoring the tubular member to the preexisting structure by heating a portion of the tubular member; and

10 axially displacing the expansion cone relative to the tubular member by pulling the expansion cone through the tubular member.

56. A method of coupling an expandable tubular member to a preexisting structure, comprising:

15 positioning the expandable tubular member, an expansion cone, and an anchoring device within the preexisting structure;

positioning the anchoring device above the expansion cone;

anchoring the expandable tubular member to the preexisting structure using the anchoring device; and

20 axially displacing the expansion cone.

57. A method of coupling an expandable tubular member to a preexisting structure, comprising:

25 positioning the tubular member and an expansion cone within the preexisting structure;

explosively anchoring the tubular member to the preexisting structure; and

axially displacing the expansion cone relative to the tubular member.

58. A method of coupling an expandable tubular to a preexisting structure,  
30 comprising:

fixing the position of an expansion cone within the preexisting structure;

driving the expandable tubular member onto the expansion cone in a first direction; and

35 axially displacing the expansion cone in a second direction relative to the expandable tubular member;

wherein the first and second directions are different.

59. A method of coupling an expandable tubular member to a preexisting structure, comprising:
- 5 placing the expandable tubular, an expansion cone, and a resilient anchor within the preexisting structure;  
releasing the resilient anchor; and  
axially displacing the expansion cone within the expandable tubular member.
- 10 60. A method of coupling an expandable tubular member to a preexisting structure, comprising:  
placing the expandable tubular member, an expansion cone, and an anchor into the preexisting structure;  
anchoring the expandable tubular member to the preexisting structure by:  
15 pivoting one or more engagement elements; and  
axially displacing the expansion cone.
61. The method of claim 60, wherein pivoting the engagement elements includes:  
20 actuating the engagement elements.
62. The method of claim 60, wherein pivoting the engagement elements includes:  
25 placing a quantity of a fluidic material onto the engagement elements.
63. The method of claim 60, wherein pivoting the engagement elements includes:  
displacing the expandable tubular member.
- 30 64. A method of coupling an expandable tubular member to a preexisting structure, comprising:  
placing the expandable tubular member and an expansion cone into the preexisting structure;  
placing a quantity of a fluidic material onto the expandable tubular member to  
35 anchor the expandable tubular member to the preexisting structure; and

axially displacing the expansion cone.

65. The method of claim 64, wherein the fluidic material comprises a barite plug.

5 66. The method of claim 64, wherein the fluidic material comprises a flex plug.

67. A method of coupling an expandable tubular member to a preexisting structure, comprising:

10 positioning the expandable tubular member and an expansion cone into the preexisting structure;

anchoring the expandable tubular member to the preexisting structure by injecting a quantity of a hardenable fluidic material into the preexisting structure;

at least partially curing the hardenable fluidic sealing material; and axially displacing the expansion cone.

15

68. A method of coupling an expandable tubular member to a preexisting structure, comprising:

placing the expandable tubular member and an expansion cone within the preexisting structure; and

20 applying an axial force to the expandable tubular member in a downward direction.

69. A method of coupling an expandable tubular member to a preexisting structure, comprising:

25 placing the expandable tubular member and an expansion cone within the preexisting structure;

injecting a quantity of a first fluidic material having a first density into the region of the preexisting structure outside of the expandable tubular member; and

30 injecting a quantity of a second fluidic material having a second density into a portion of the expandable tubular member below the expansion cone;

wherein the second density is greater than the first density.

70. A method of coupling an expandable tubular member to a preexisting structure, comprising:

:

placing the expandable tubular member and an expansion cone into the preexisting structure;

anchoring the expandable tubular member to the preexisting structure;

applying an axial force to the expansion cone; and

5       pressurizing an interior portion of the expandable tubular member below the expansion cone.

71.    A method of coupling an expandable tubular member to a preexisting structure, comprising:

10       placing the expandable tubular member and an expansion cone into the preexisting structure; and

applying an axial force to the expandable tubular member.

72.    An apparatus for coupling a tubular member to a preexisting structure, comprising:

15

an expandable tubular member;

an anchoring device adapted to couple the expandable tubular member to the preexisting structure; and

20       an expansion cone movably coupled to the expandable tubular member and adapted to radially expand the expandable tubular member, including:

a housing including a tapered first end and a second end;

one or more grooves formed in the outer surface of the tapered first end; and

one or more axial flow passages fluidically coupled to the grooves.

25    73.    The apparatus of claim 72, wherein the grooves comprise circumferential grooves.

74.    The apparatus of claim 72, wherein the grooves comprise spiral grooves.

30    75.    The apparatus of claim 72, wherein the grooves are concentrated around the axial midpoint of the tapered portion of the housing.

76.    The apparatus of claim 72, wherein the axial flow passages comprise axial grooves.

35

77. The apparatus of claim 76, wherein the axial grooves are spaced apart by at least about 3 inches in the circumferential direction.
78. The apparatus of claim 76, wherein the axial grooves extend from the tapered first end of the body to the grooves.
79. The apparatus of claim 76, wherein the axial grooves extend from the second end of the body to the grooves.
80. The apparatus of claim 76, wherein the axial grooves extend from the tapered first end of the body to the second end of the body.
81. The apparatus of claim 72, wherein the axial flow passages are positioned within the housing of the expansion cone.
82. The apparatus of claim 81, wherein the axial flow passages extend from the tapered first end of the body to the grooves.
83. The apparatus of claim 81, wherein the axial flow passages extend from the tapered first end of the body to the second end of the body.
84. The apparatus of claim 83, wherein the axial flow passages extend from the second end of the body to the grooves.
85. The apparatus of claim 83, wherein one or more of the flow passages include inserts having restricted flow passages.
86. The apparatus of claim 83, wherein one or more of the axial flow passages include filters.
87. The apparatus of claim 72, wherein the cross sectional area of the grooves is greater than the cross sectional area of the axial flow passages.
88. The apparatus of claim 72, wherein the cross-sectional area of the grooves ranges from about  $2 \times 10^{-4} \text{ in}^2$  to  $5 \times 10^{-2} \text{ in}^2$ .

89. The apparatus of claim 72, wherein the cross-sectional area of the axial flow passages ranges from about  $2 \times 10^{-4}$  in<sup>2</sup> to  $5 \times 10^{-2}$  in<sup>2</sup>.
- 5 90. The apparatus of claim 72, wherein the angle of attack of the first tapered end of the body ranges from about 10 to 30 degrees.
91. The apparatus of claim 72, wherein the grooves are concentrated in a trailing edge portion of the tapered first end.
- 10 92. The apparatus of claim 72, wherein the angle of inclination of the axial flow passages relative to the longitudinal axis of the expansion cone is greater than the angle of attack of the first tapered end.
- 15 93. The apparatus of claim 72, wherein the grooves include:  
a flow channel having a first radius of curvature;  
a first shoulder positioned on one side of the flow channel having a second radius of curvature; and  
a second shoulder positioned on the other side of the flow channel having a  
20 third radius of curvature.
94. The apparatus of claim 93, wherein the first, second and third radii of curvature are substantially equal.
- 25 95. The apparatus of claim 72, wherein the axial flow passages include:  
a flow channel having a first radius of curvature;  
a first shoulder positioned on one side of the flow channel having a second radius of curvature; and  
a second shoulder positioned on the other side of the flow channel having a  
30 third radius of curvature.
96. The apparatus of claim 95, wherein the first, second and third radii of curvature are substantially equal.

97. The apparatus of claim 95, wherein the second radius of curvature is greater than the third radius of curvature.

98. An apparatus for coupling an expandable tubular member to a preexisting structure, comprising:  
5 an expandable tubular member;  
an anchoring device adapted to couple the expandable tubular member to the preexisting structure; and  
an expansion cone movably coupled to the expandable tubular member and  
10 adapted to radially expand the expandable tubular member;  
wherein the expandable tubular member includes:  
an annular member, having:  
a wall thickness that varies less than about 8 %;  
a hoop yield strength that varies less than about 10 %;  
15 imperfections of less than about 8 % of the wall thickness;  
no failure for radial expansions of up to about 30 %; and  
no necking of the walls of the annular member for radial expansions of up to about 25%.

20 99. An apparatus for coupling an expandable tubular member to a preexisting structure, comprising:  
an expandable tubular member;  
an anchoring device adapted to couple the expandable tubular member to the preexisting structure; and  
25 an expansion cone movably coupled to the expandable tubular member and adapted to radially expand the expandable tubular member;  
wherein the expandable tubular member includes:  
a first tubular member;  
a second tubular member; and  
30 a threaded connection for coupling the first tubular member to the second tubular member, the threaded connection including:  
one or more sealing members for sealing the interface between the first and second tubular members.

100. The apparatus of claim 99, wherein the threaded connection comprises a pin and box threaded connection.
101. The apparatus of claim 99, wherein the sealing members are positioned adjacent to an end portion of the threaded connection.
102. The apparatus of claim 99, wherein one of the sealing members is positioned adjacent to an end portion of the threaded connection; and wherein another one of the sealing members is not positioned adjacent to an end portion of the threaded connection.
103. The apparatus of claim 99, wherein a plurality of the sealing members are positioned adjacent to an end portion of the threaded connection.
104. An apparatus for coupling an expandable tubular member to a preexisting structure, comprising:  
an expandable tubular member;  
an anchoring device adapted to couple the expandable tubular member to the preexisting structure; and  
an expansion cone movably coupled to the expandable tubular member and adapted to radially expand the expandable tubular member;  
wherein the expandable tubular member includes:  
a layer of a lubricant coupled to the interior surface of the tubular member.
105. The apparatus of claim 104, wherein the lubricant comprises a metallic soap.
106. The apparatus of claim 104, wherein the lubricant is selected from the group consisting of C-Lube-10, C-PHOS-58-M, and C-PHOS-58-R.
107. The apparatus of claim 104, wherein the lubricant provides a sliding friction coefficient of less than about 0.20.
108. The apparatus of claim 104, wherein the lubricant is chemically bonded to the interior surface of the expandable tubular member.

35



109. The apparatus of claim 104, wherein the lubricant is mechanically bonded to the interior surface of the expandable tubular member.

5 110. The apparatus of claim 104, wherein the lubricant is adhesively bonded to the interior surface of the expandable tubular member.

10 111. The apparatus of claim 110, wherein the lubricant includes epoxy, molybdenum disulfide, graphite, aluminum, copper, aluminosilicate and polyethylenepolyamine.

112. An apparatus for coupling an expandable tubular member to a preexisting structure, comprising:  
an expandable tubular member;  
an anchoring device adapted to couple the expandable tubular member to  
15 the preexisting structure; and  
an expansion cone movably coupled to the expandable tubular member and adapted to radially expand the expandable tubular member;  
wherein the expandable tubular member includes:  
a pair of tubular members having threaded portions coupled to one another;  
20 and  
a quantity of a sealant within the threaded portions of the tubular members.

113. The apparatus of claim 112, wherein the sealant is selected from the group consisting of epoxies, thermosetting sealing compounds, curable sealing  
25 compounds, and sealing compounds having polymerizable materials.

114. The apparatus of claim 112, wherein the sealant includes an initial cure cycle and a final cure cycle.

30 115. The apparatus of claim 112, wherein the sealant can be stretched up to about 30 to 40 percent without failure.

116. The apparatus of claim 112, wherein the sealant is resistant to conventional wellbore fluidic materials.  
35

117. The apparatus of claim 112, wherein the material properties of the sealant are substantially stable for temperatures ranging from about 0 to 450 °F.

118. The apparatus of claim 112, wherein the threaded portions of the tubular members include a primer for improving the adhesion of the sealant to the threaded portions.

119. An apparatus for coupling an expandable tubular member to a preexisting structure, comprising:

- an expandable tubular member;
- an anchoring device adapted to couple the expandable tubular member to the preexisting structure; and
- an expansion cone movably coupled to the expandable tubular member and adapted to radially expand the expandable tubular member;

wherein the expandable tubular member includes: a pair of rings for engaging the preexisting structure; and

- a sealing element positioned between the rings for sealing the interface between the tubular member and the preexisting structure.

120. An apparatus for coupling an expandable tubular member to a preexisting structure, comprising:

- an expandable tubular member;
- an anchoring device adapted to couple the expandable tubular member to the preexisting structure; and
- an expansion cone movably coupled to the expandable tubular member and adapted to radially expand the expandable tubular member;

wherein the expandable tubular member includes one or more slots.

121. The apparatus of claim 120, wherein the slots are provided at a preexpanded portion of the expandable tubular member.

122. The apparatus of claim 120, wherein the slots are provided at a non-preexpanded portion of the tubular member.

123. An apparatus for coupling an expandable tubular member to a preexisting structure, comprising:

an expandable tubular member;

an anchoring device adapted to couple the expandable tubular member to  
5 the preexisting structure; and

an expansion cone movably coupled to the expandable tubular member and adapted to radially expand the expandable tubular member;

wherein the expandable tubular member includes:

a first preexpanded portion;

10 an intermediate portion coupled to the first preexpanded portion including a sealing element; and

a second preexpanded portion coupled to the intermediate portion.

124. An apparatus for coupling an expandable tubular member to a preexisting  
15 structure, comprising:

an expandable tubular member;

an anchoring device adapted to couple the expandable tubular member to  
the preexisting structure;

20 an expansion cone movably coupled to the expandable tubular member and adapted to radially expand the expandable tubular member; and

a valveable fluid passage coupled to the anchoring device.

125. An apparatus for coupling an expandable tubular member to a preexisting  
structure, comprising:

25 a first support member;

a second support member coupled to the first support member;

an expansion cone coupled to the first support member;

an expandable tubular member coupled to the expansion cone; and

30 an anchoring device coupled to the second support member adapted to couple the expandable tubular member to the preexisting structure;

wherein the anchoring device is positioned above the expansion cone.

126. The apparatus of claim 125, wherein the outside diameter of the expansion  
cone is greater than the inside diameter of the expandable tubular member.

35

127. The apparatus of claim 125, wherein the outside diameter of the expansion cone is approximately equal to the outside diameter of the expandable tubular member.

5 128. An apparatus for coupling an expandable tubular member to a preexisting structure, comprising:

a first support member;

a second support member coupled to the first support member;

an expansion cone coupled to the first support member;

10 an expandable tubular member coupled to the expansion cone; and

an explosive anchoring device coupled to the second support member adapted to couple the expandable tubular member to the preexisting structure.

129. An apparatus for coupling an expandable tubular member to a preexisting structure, comprising:

15

a support member;

an expandable expansion cone coupled to the support member; and

an expandable tubular member coupled to the expansion cone.

20 130. An apparatus for coupling an expandable tubular member to a preexisting structure, comprising:

a support member;

an expandable expansion cone coupled to the support member; and

an expandable tubular member coupled to the expandable expansion cone.

25

131. The apparatus of claim 130, wherein the expandable tubular member includes one or more anchoring devices.

132. The apparatus of claim 130, wherein the expandable tubular member includes a slotted end portion.

30

133. An apparatus for coupling an expandable tubular to a preexisting structure, comprising:

a support member;

35

an expansion cone coupled to the support member;

an expandable tubular member coupled to the expansion cone including one or more shape memory metal inserts; and

a heater coupled to the support member in opposing relation to the shape memory metal inserts.

5

134. An apparatus for coupling an expandable tubular member to a preexisting structure, comprising:

a support member;

an expansion cone coupled to the support member;

10 an expandable tubular member coupled to the expandable expansion cone;

and

a resilient anchor coupled to the expandable tubular member.

135. The apparatus of claim 134, wherein the resilient anchor includes:

15

a resilient scroll.

136. The apparatus of claim 134, wherein the resilient anchor includes:

one or more resilient arms.

20

137. The apparatus of claim 134, wherein the resilient anchor includes:

one or more resilient radially oriented elements.

138. The apparatus of claim 134, wherein the resilient anchor is adapted to mate with the expansion cone.

25

139. An expandable tubular member, comprising:

an expandable tubular body;

one or more resilient panels coupled to the expandable tubular body; and

a release member releasably coupled to the resilient panels adapted to

30 controllably release the resilient panels.

140. An apparatus for coupling an expandable tubular member to a preexisting structure, comprising:

a support member;

35

an expansion cone coupled to the support member;

- an expandable tubular member coupled to the expandable expansion cone;  
and  
an anchor coupled to the expandable tubular member, including:  
one or more spikes pivotally coupled to the expandable tubular member for  
5 engaging the preexisting structure.
141. The apparatus of claim 140, further including one or more corresponding  
actuators for pivoting the spikes.
- 10 142. An apparatus for coupling an expandable tubular member to a preexisting  
structure, comprising:  
a support member;  
an expansion cone coupled to the support member;  
an expandable tubular member coupled to the expandable expansion cone;  
15 and  
an anchor coupled to the expandable tubular member, including:  
one or more petal baskets pivotally coupled to the expandable tubular  
member.
- 20 143. The apparatus of claim 142, further including one or more corresponding  
actuators for pivoting the petal baskets.
144. An apparatus for coupling an expandable tubular member to a preexisting  
structure, comprising:  
25 a support member;  
an expansion cone coupled to the support member;  
an expandable tubular member coupled to the expansion cone, including:  
a slotted portion provided at one end of the expandable tubular member.
- 30 145. An apparatus for coupling an expandable tubular member to a preexisting  
structure, comprising:  
a support member;  
an expansion cone;  
an expandable tubular member coupled to the expansion cone;

-----  
a coupling device coupled to the support member and an end portion of the expandable tubular member; and

a mass coupled to the end portion of the expandable tubular member;

wherein the weight of the mass is greater than about 50 to 100 % of the yield  
5 strength of the expandable tubular member.

146. An apparatus for coupling an expandable tubular member to a preexisting structure, comprising:

a support member including a fluid passage;

10 an expansion cone coupled to the support member;

an expandable tubular member coupled to the expansion cone;

a slip joint coupled to the expansion cone;

an end plate coupled to the slip joint;

15 a fluid chamber coupled to the fluid passage, the fluid chamber defined by the interior portion of the expandable tubular member between the expansion cone and the end plate.

147. A method of coupling a tubular member to a preexisting structure, comprising:

20 positioning the tubular member and an expansion cone within the preexisting structure;

axially displacing the expansion cone;

removing the expansion cone; and

applying direct radial pressure to the tubular member.

25

148. The method of claim 147, wherein axially displacing the expansion cone includes:

pressurizing at least a portion of the interior of the tubular member.

30 149. The method of claim 147, wherein axially displacing the expansion cone includes:

injecting a fluidic material into the tubular member.

150. The method of claim 147, wherein axially displacing the expansion cone  
35 includes:

applying a tensile force to the expansion cone.

151. The method of claim 147, wherein axially displacing the expansion cone includes:

5 displacing the expansion cone into the tubular member.

152. The method of claim 147, wherein axially displacing the expansion cone includes:

10 displacing the expansion cone out of the tubular member.

153. The method of claim 147, wherein axially displacing the expansion cone radially expands the tubular member by about 10% to 20%.

154. The method of claim 147, wherein applying direct radial pressure to the first  
15 tubular member radially expands the tubular member by up to about 5%.

155. The method of claim 147, wherein applying direct radial pressure to the tubular member includes applying a radial force at discrete locations.

20 156. The method of claim 147, wherein the preexisting structure includes a wellbore casing.

157. The method of claim 147, wherein the preexisting structure includes a  
25 pipeline.

158. The method of claim 147, wherein the preexisting structure includes a structural support.

159. An apparatus, comprising:  
30 a tubular member coupled to a preexisting structure;  
wherein the tubular member is coupled to the preexisting structure by the process of:  
positioning the tubular member and an expansion cone within the preexisting structure;  
35 axially displacing the expansion cone;



removing the expansion cone; and  
applying direct radial pressure to the tubular member.

5 160. The apparatus of claim 159, wherein axially displacing the expansion cone includes:  
pressurizing at least a portion of the interior of the tubular member.

10 161. The apparatus of claim 159, wherein axially displacing the expansion cone includes:  
injecting a fluidic material into the tubular member.

15 162. The apparatus of claim 159, wherein axially displacing the expansion cone includes:  
applying a tensile force to the expansion cone.

163. The apparatus of claim 159, wherein axially displacing the expansion cone includes:  
displacing the expansion cone into the tubular member.

20 164. The apparatus of claim 159, wherein axially displacing the expansion cone includes:  
displacing the expansion cone out of the tubular member.

25 165. The apparatus of claim 159, wherein axially displacing the expansion cone radially expands the tubular member by about 10% to 20%.

166. The apparatus of claim 159, wherein applying direct radial pressure to the tubular member radially expands the tubular member by up to about 5%.

30 167. The apparatus of claim 159, wherein applying direct radial pressure to the tubular member includes applying a radial force at discrete locations.

35 168. The apparatus of claim 159, wherein the preexisting structure includes a wellbore casing.

169. The apparatus of claim 159, wherein the preexisting structure includes a pipeline.

170. The apparatus of claim 159, wherein the preexisting structure includes a structural support.

171. A system for coupling an expandable tubular member to a preexisting structure, comprising:

means for positioning the tubular member and an expansion cone within the preexisting structure;

means for anchoring the tubular member to the preexisting structure;

means for axially displacing the expansion cone relative to the tubular member by pulling the expansion cone through the tubular member; and

means for lubricating the interface between the expansion cone and the tubular member.

172. The system of claim 171, wherein the means for lubricating the interface between the expansion cone and the tubular member includes:

means for injecting a lubricating fluid into the trailing edge of the interface between the expansion cone and the tubular member.

173. The system of claim 172, wherein the lubricating fluid has a viscosity ranging from about 1 to 10,000 centipoise.

174. The system of claim 172, wherein the injecting includes:

injecting lubricating fluid into a tapered end of the expansion cone.

175. The system of claim 172, wherein the means for injecting includes:

means for injecting lubricating fluid into the area around the axial midpoint of a first tapered end of the expansion cone.

176. The system of claim 172, wherein the means for injecting includes:

means for injecting lubricating fluid into a second end of the expansion cone.

177. The system of claim 172, wherein the means for injecting includes:

means for injecting lubricating fluid into a tapered first end and a second end of the expansion cone.

5 178. The system of claim 172, wherein the means for injecting includes:  
means for injecting lubricating fluid into an interior of the expansion cone.

10 179. The system of claim 172, wherein the means for injecting includes:  
means for injecting lubricating fluid through an outer surface of the expansion cone.

180. The system of claim 172, wherein the means for injecting includes:  
means for injecting the lubricating fluid into a plurality of discrete locations along the trailing edge portion.

15 181. The system of claim 172, wherein the lubricating fluid comprises:  
drilling mud.

20 182. The system of claim 172, wherein the lubricating fluid further includes:  
TorqTrim III;  
EP Mudlib; and  
DrillN-Slid.

25 183. The system of claim 172, wherein the lubricating fluid comprises:  
TorqTrim III;  
EP Mudlib; and  
DrillN-Slid.

30 184. The system of claim 711, wherein the means for lubricating the interface between the expansion cone and the tubular member includes:  
means for coating the interior surface of the tubular member with a lubricant.

35 185. The system of claim 171, wherein the means for lubricating the interface between the expansion cone and the tubular member includes:  
means for coating the interior surface of the tubular member with a first part of a lubricant; and

means for applying a second part of the lubricant to the interior surface of the tubular member.

5 186. The system of claim 184, wherein the lubricant comprises a metallic soap.

187. The system of claim 184, wherein the lubricant is selected from the group consisting of C-Lube-10, C-PHOS-58-M, and C-PHOS-58-R.

10 188. The system of claim 184, wherein the lubricant provides a sliding friction coefficient of less than about 0.20.

189. The system of claim 184, wherein the lubricant is chemically bonded to the interior surfaces of the tubular members.

15 190. The system of claim 184, wherein the lubricant is mechanically bonded to the interior surfaces of the tubular members.

191. The system of claim 184, wherein the lubricant is adhesively bonded to the interior surface of the tubular members.

20 192. The system of claim 184, wherein the lubricant includes epoxy, molybdenum disulfide, graphite, aluminum, copper, aluminosilicate and polyethylenepolyamine.

25 193. A system for coupling a tubular member to a preexisting structure, comprising:

positioning the tubular member and an expansion cone within the preexisting structure;

anchoring the tubular member to the preexisting structure; and

axially displacing the expansion cone relative to the tubular member by

30 pulling the expansion cone through the tubular member;

wherein the tubular member includes:

an annular member, including:

a wall thickness that varies less than about 8 %;

a hoop yield strength that varies less than about 10 %;

35 imperfections of less than about 8 % of the wall thickness;

no failure for radial expansions of up to about 30 %; and  
no necking of the walls of the annular member for radial expansions of up to  
about 25%.

- 5 194. A system for coupling a tubular member to a preexisting structure,  
comprising:  
injecting a lubricating fluid into the preexisting structure;  
positioning the tubular member and an expansion cone within the preexisting  
structure;
- 10 anchoring the tubular member to the preexisting structure; and  
axially displacing the expansion cone relative to the tubular member by  
pulling the expansion cone through the tubular member.
- 15 195. The system of claim 194, wherein the lubricating fluid comprises:  
BARO-LUB GOLD-SEAL™ brand drilling mud lubricant.
196. A system for coupling an expandable tubular member to a preexisting  
structure, comprising:  
means for positioning the expandable tubular member and an expansion  
20 cone within the preexisting structure;  
means for anchoring the expandable tubular member to the preexisting  
structure; and  
means for axially displacing the expansion cone relative to the expandable  
tubular member by pulling the expansion cone through the expandable tubular  
25 member;
- wherein the expandable tubular member includes:  
a first tubular member;  
a second tubular member; and  
a threaded connection for coupling the first tubular member to the second  
30 tubular member, the threaded connection including:  
one or more sealing members for sealing the interface between the first and  
second tubular members.
- 35 197. The system of claim 196, wherein the threaded connection comprises a pin  
and box threaded connection.

198. The system of claim 196, wherein the sealing members are positioned adjacent to an end portion of the threaded connection.

5 199. The system of claim 196, wherein one of the sealing members is positioned adjacent to an end portion of the threaded connection; and wherein another one of the sealing members is not positioned adjacent to an end portion of the threaded connection.

10 200. The system of claim 196, wherein a plurality of the sealing members are positioned adjacent to an end portion of the threaded connection.

201. A system for coupling an expandable tubular member to a preexisting structure, comprising:

15 means for positioning the expandable tubular member and an expansion cone within the preexisting structure;

means for anchoring the expandable tubular member to the preexisting structure; and

20 means for axially displacing the expansion cone relative to the expandable tubular member by pulling the expansion cone through the expandable tubular member;

wherein the expandable tubular member includes a plurality of tubular members having threaded portions that are coupled to one another by the process of:

25 coating the threaded portions of the tubular members with a sealant; coupling the threaded portions of the tubular members; and curing the sealant.

30 202. The system of claim 201, wherein the sealant is selected from the group consisting of epoxies, thermosetting sealing compounds, curable sealing compounds, and sealing compounds having polymerizable materials.

203. The system of claim 201, further including:

35 means for initially curing the sealant prior to radially expanding the tubular members; and

means for finally curing the sealant after radially expanding the tubular members.

204. The system of claim 201, wherein the sealant can be stretched up to about  
5 30 to 40 percent after curing without failure.

205. The system of claim 201, wherein the sealant is resistant to conventional wellbore fluidic materials.

10 206. The system of claim 201, wherein the material properties of the sealant are substantially stable for temperatures ranging from about 0 to 450 °F.

207. The system of claim 201, further including:  
means for applying a primer to the threaded portions of the tubular members  
15 prior to coating the threaded portions of the tubular members with the sealant.

208. The system of claim 207, wherein the primer includes a curing catalyst.

209. The system of claim 207, wherein the primer is applied to the threaded  
20 portion of one of the tubular members and the sealant is applied to the threaded portion of the other one of the tubular members.

210. The system of claim 207, wherein the primer includes a curing catalyst.

25 211. A system for coupling a tubular member to a preexisting structure, comprising:  
positioning the tubular member and an expansion cone within the preexisting structure;  
anchoring the tubular member to the preexisting structure; and  
30 axially displacing the expansion cone relative to the tubular member by pulling the expansion cone through the expandable tubular member;  
wherein the tubular member includes:  
a pair of rings for engaging the preexisting structure; and  
a sealing element positioned between the rings for sealing the interface  
35 between the tubular member and the preexisting structure.

212. A system for coupling a tubular member to a preexisting structure, comprising:
- 5 positioning the expandable tubular member and an expansion cone within the preexisting structure;
  - anchoring the expandable tubular member to the preexisting structure; and
  - axially displacing the expansion cone relative to the expandable tubular member by pulling the expansion cone through the expandable tubular member;
  - 10 wherein the tubular member includes one or more slots.
213. The system of claim 212, wherein the slots are provided at a preexpanded portion of the tubular member.
214. The system of claim 212, wherein the slots are provided at a non-  
15 preexpanded portion of the tubular member.
215. A system for coupling a tubular member to a preexisting structure, comprising:
- 20 positioning the expandable tubular member and an expansion cone within the preexisting structure;
  - anchoring the expandable tubular member to the preexisting structure; and
  - axially displacing the expansion cone relative to the expandable tubular member by pulling the expansion cone through the expandable tubular member;
  - 25 wherein the tubular member includes:
    - a first preexpanded portion;
    - an intermediate portion coupled to the first preexpanded portion including a sealing element; and
    - a second preexpanded portion coupled to the intermediate portion.
- 30 216. A system for coupling a tubular member to a preexisting structure, comprising:
- positioning the expandable tubular member and an expansion cone within the preexisting structure;
  - anchoring the expandable tubular member to the preexisting structure; and



axially displacing the expansion cone relative to the expandable tubular member by pulling the expansion cone through the expandable tubular member by applying an axial force to the expansion cone;

wherein the axial force includes:

- 5 a substantially constant axial force; and  
an increased axial force.

217. The system of claim 216, wherein the increased axial force is provided on a periodic basis.

10

218. The system of claim 216, wherein the increased axial force is provided on a random basis.

219. The system of claim 216, wherein the ratio of the increased axial force to the substantially constant axial force ranges from about 5 to 40 %.

15

220. A system for coupling a tubular member to a preexisting structure, comprising:

means for positioning the tubular member and an expansion cone within the preexisting structure;

20

means for anchoring the tubular member to the preexisting structure; and

means for axially displacing the expansion cone relative to the expandable tubular member by pushing and pulling the expansion cone through the expandable tubular member.

25

221. The system of claim 220, wherein the means for pushing the expansion cone includes:

means for injecting a pressurized fluidic material into contact with the expansion cone.

30

222. A system for coupling a tubular member to a preexisting structure, comprising:

means for positioning the tubular member and an expansion cone within the preexisting structure;

35

means for anchoring the tubular member to the preexisting structure;

means for axially displacing the expansion cone relative to the tubular member by pulling the expansion cone through the expandable tubular member; and

5 means for injecting a curable fluidic sealing material between the tubular member and the preexisting structure prior to axially displacing the expansion cone.

223. A system for coupling a tubular member to a preexisting structure, comprising:

10 means for positioning the tubular member and an expansion cone within the preexisting structure;

means for anchoring the tubular member to the preexisting structure by increasing the size of the expansion cone; and

means for axially displacing the expansion cone relative to the tubular member by pulling the expansion cone through the tubular member.

15

224. A system for coupling a tubular member to a preexisting structure, comprising:

means for positioning the tubular member and an expansion cone within the preexisting structure;

20 means for anchoring the tubular member to the preexisting structure by heating a portion of the tubular member; and

means for axially displacing the expansion cone relative to the tubular member by pulling the expansion cone through the tubular member.

25 225. A system for coupling an expandable tubular member to a preexisting structure, comprising:

means for positioning the expandable tubular member, an expansion cone, and an anchoring device within the preexisting structure;

30 means for positioning the anchoring device above the expansion cone;

means for anchoring the expandable tubular member to the preexisting structure using the anchoring device; and

means for axially displacing the expansion cone.

35 226. A system for coupling an expandable tubular member to a preexisting structure, comprising:

means for positioning the tubular member and an expansion cone within the preexisting structure;

means for explosively anchoring the tubular member to the preexisting structure; and

5 means for axially displacing the expansion cone relative to the tubular member.

227. A system for coupling an expandable tubular to a preexisting structure, comprising:

10 means for fixing the position of an expansion cone within the preexisting structure;

means for driving the expandable tubular member onto the expansion cone in a first direction; and

15 means for axially displacing the expansion cone in a second direction relative to the expandable tubular member;

wherein the first and second directions are different.

228. A system for coupling an expandable tubular member to a preexisting structure, comprising:

20 means for placing the expandable tubular, an expansion cone, and a resilient anchor within the preexisting structure;

means for releasing the resilient anchor; and

means for axially displacing the expansion cone within the expandable tubular member.

25

229. A system for coupling an expandable tubular member to a preexisting structure, comprising:

means for placing the expandable tubular member, an expansion cone, and an anchor into the preexisting structure;

30 means for anchoring the expandable tubular member to the preexisting structure that includes means for pivoting one or more engagement elements; and

means for axially displacing the expansion cone.

230. The system of claim 229, wherein the means for pivoting the engagement elements includes:

35

means for actuating the engagement elements.

231. The system of claim 229, wherein the means for pivoting the engagement elements includes:

5 means for placing a quantity of a fluidic material onto the engagement elements.

232. The system of claim 229, wherein the means for pivoting the engagement elements includes:

10 means for displacing the expandable tubular member.

233. A system for coupling an expandable tubular member to a preexisting structure, comprising:

15 means for placing the expandable tubular member and an expansion cone into the preexisting structure;

means for placing a quantity of a fluidic material onto the expandable tubular member to anchor the expandable tubular member to the preexisting structure; and

means for axially displacing the expansion cone.

20 234. The system of claim 233, wherein the fluidic material comprises a barite plug.

235. The system of claim 233, wherein the fluidic material comprises a flex plug.

25 236. A system for coupling an expandable tubular member to a preexisting structure, comprising:

means for positioning the expandable tubular member and an expansion cone into the preexisting structure;

30 means for anchoring the expandable tubular member to the preexisting structure by injecting a quantity of a hardenable fluidic material into the preexisting structure;

means for at least partially curing the hardenable fluidic sealing material; and  
means for axially displacing the expansion cone.

35 237. A system for coupling an expandable tubular member to a preexisting structure, comprising:

means for placing the expandable tubular member and an expansion cone within the preexisting structure; and

means for applying an axial force to the expandable tubular member in a downward direction.

5

238. A system for coupling an expandable tubular member to a preexisting structure, comprising:

means for placing the expandable tubular member and an expansion cone within the preexisting structure;

10 means for injecting a quantity of a first fluidic material having a first density into the region of the preexisting structure outside of the expandable tubular member; and

means for injecting a quantity of a second fluidic material having a second density into a portion of the expandable tubular member below the expansion cone;

15 wherein the second density is greater than the first density.

239. A system for coupling an expandable tubular member to a preexisting structure, comprising:

20 means for placing the expandable tubular member and an expansion cone into the preexisting structure;

means for anchoring the expandable tubular member to the preexisting structure;

means for applying an axial force to the expansion cone; and

25 means for pressurizing an interior portion of the expandable tubular member below the expansion cone.

240. A system for coupling an expandable tubular member to a preexisting structure, comprising:

30 means for placing the expandable tubular member and an expansion cone into the preexisting structure; and

means for applying an axial force to the expandable tubular member.

241. A system for coupling a tubular member to a preexisting structure, comprising:

means for positioning the tubular member and an expansion cone within the preexisting structure;

means for axially displacing the expansion cone;

means for removing the expansion cone; and

5 means for applying direct radial pressure to the tubular member.

242. The system of claim 241, wherein the means for axially displacing the expansion cone includes:

10 means for pressurizing at least a portion of the interior of the tubular member.

243. The system of claim 241, wherein the means for axially displacing the expansion cone includes:

15 means for injecting a fluidic material into the tubular member.

244. The system of claim 241, wherein the means for axially displacing the expansion cone includes:

means for applying a tensile force to the expansion cone.

20 245. The system of claim 241, wherein the means for axially displacing the expansion cone includes:

means for displacing the expansion cone into the tubular member.

25 246. The system of claim 241, wherein the means for axially displacing the expansion cone includes:

means for displacing the expansion cone out of the tubular member.

247. The system of claim 241, wherein the means for axially displacing the expansion cone radially expands the tubular member by about 10% to 20%.

30

248. The system of claim 241, wherein the means for applying direct radial pressure to the first tubular member radially expands the tubular member by up to about 5%.

249. The system of claim 241, wherein the means for applying direct radial pressure to the tubular member includes means for applying a radial force at discrete locations.

5 250. The system of claim 241, wherein the preexisting structure includes a wellbore casing.

251. The system of claim 241, wherein the preexisting structure includes a pipeline.

10

252. The system of claim 241, wherein the preexisting structure includes a structural support.



INVESTOR IN PEOPLE

Application No: GB0404826.0

Examiner: Dave Pepper

Claims searched: 1 to 26

Date of search: 20 April 2004

### Patents Act 1977: Search Report under Section 17

#### Documents considered to be relevant:

Category	Relevant to claims	Identity of document and passage or figure of particular reference
A	-	GB 2356651 A Shell Internationale Research
A	-	WO 01/04535 A Enventure Global Technology

#### Categories:

X	Document indicating lack of novelty or inventive step	A	Document indicating technological background and/or state of the art.
Y	Document indicating lack of inventive step if combined with one or more other documents of same category.	P	Document published on or after the declared priority date but before the filing date of this invention.
&	Member of the same patent family	E	Patent document published on or after, but with priority date earlier than, the filing date of this application.

#### Field of Search:

Search of GB, EP, WO & US patent documents classified in the following areas of the UKC<sup>w</sup> :

E1F

Worldwide search of patent documents classified in the following areas of the IPC<sup>07</sup>

E21B

The following online and other databases have been used in the preparation of this search report

Online: WPI, EPODOC