



(12) **United States Patent**
Cappello et al.

(10) **Patent No.:** **US 11,185,757 B2**
(45) **Date of Patent:** **Nov. 30, 2021**

(54) **SKATEBOARDS WITH A MULTI-WHEEL TRUCK**

(71) Applicant: **KARSTEN MANUFACTURING CORPORATION**, Phoenix, AZ (US)

(72) Inventors: **Dylan R. Cappello**, Peoria, AZ (US);
David L. Petersen, Peoria, AZ (US);
John A. Solheim, Phoenix, AZ (US)

(73) Assignee: **Karsten Manufacturing Corporation**, Phoenix, AZ (US)

(*) Notice: Subject to any disclaimer, the term of this patent is extended or adjusted under 35 U.S.C. 154(b) by 0 days.

(21) Appl. No.: **16/826,630**

(22) Filed: **Mar. 23, 2020**

(65) **Prior Publication Data**
US 2020/0298096 A1 Sep. 24, 2020

Related U.S. Application Data
(60) Provisional application No. 62/822,412, filed on Mar. 22, 2019, provisional application No. 62/880,562, filed on Jul. 30, 2019.

(51) **Int. Cl.**
A63C 17/01 (2006.01)

(52) **U.S. Cl.**
CPC **A63C 17/014** (2013.01); **A63C 17/012** (2013.01)

(58) **Field of Classification Search**
CPC A63C 17/014; A63C 17/04; A63C 17/012
See application file for complete search history.

(56) **References Cited**

U.S. PATENT DOCUMENTS

4,062,557 A	12/1977	Roden	
4,337,961 A	7/1982	Covert	
4,817,974 A	4/1989	Bergeron	
4,911,456 A *	3/1990	Sarazen	A63C 17/1409
			280/11.204
5,947,495 A	9/1999	Null	
6,158,753 A	12/2000	Sturbaum	
6,431,568 B1	8/2002	McCleese	
8,608,185 B2	12/2013	Bermal	
8,807,577 B2 *	8/2014	Lai	A63C 17/0046
			280/11.28
9,492,731 B2 *	11/2016	Marusiak	A63C 17/0093
9,573,045 B2 *	2/2017	Lai	A63C 17/014
9,604,124 B2	3/2017	Aders	
2003/0141688 A1	7/2003	Lynn	
2010/0090423 A1	4/2010	Farrelly	
2013/0175777 A1	7/2013	Bermal	
2013/0181417 A1	7/2013	Smith	
2014/0197611 A1	7/2014	Lai	

(Continued)

FOREIGN PATENT DOCUMENTS

FR	2766382	1/1999
FR	2810894	1/2002

(Continued)

OTHER PUBLICATIONS

PCT International Search Report and Written Opinion dated Jun. 22, 2020 from corresponding PCT Application No. PCT/US2020/024164.

Primary Examiner — Brian L Swenson

(57) **ABSTRACT**

A moving wheel platform that minimizes wheel interactions with noncontinuous and uneven surfaces. The platform provides rotation-inhibiting structures onto or into the moving wheel platforms that aids with eliminating wheel bite.

20 Claims, 16 Drawing Sheets

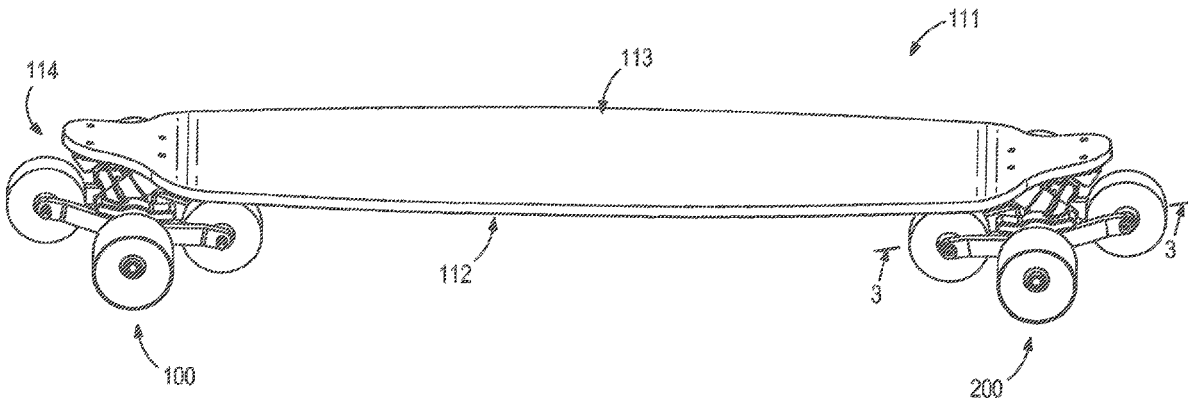

(56)

References Cited

U.S. PATENT DOCUMENTS

2016/0074743	A1	3/2016	Marusiak
2016/0151699	A1	6/2016	Lai
2018/0185738	A1	7/2018	Strand

FOREIGN PATENT DOCUMENTS

KR	20050060368	6/2005
KR	200390293	7/2005
WO	1998005390	2/1998
WO	2002020100	3/2002
WO	2003033089	4/2003
WO	2006061528	6/2006
WO	2009156528	12/2009

* cited by examiner

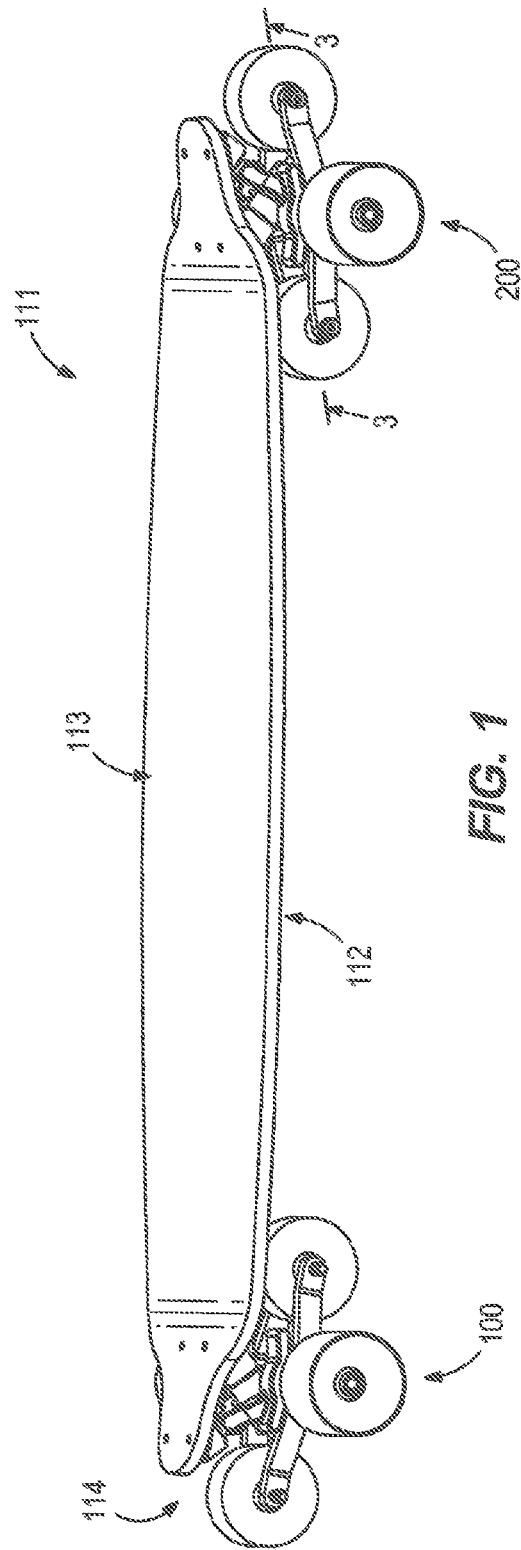

FIG. 1

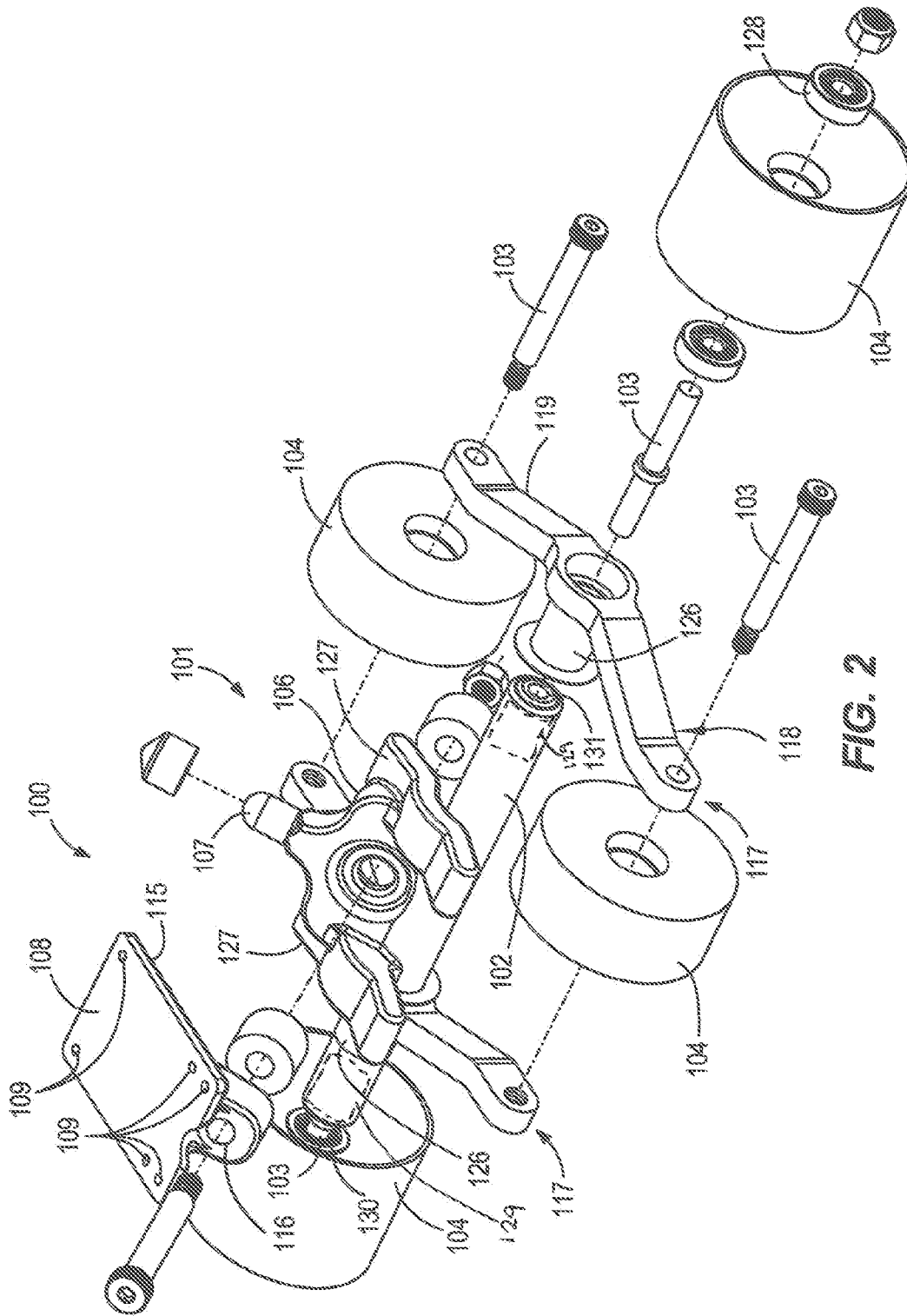

FIG. 2

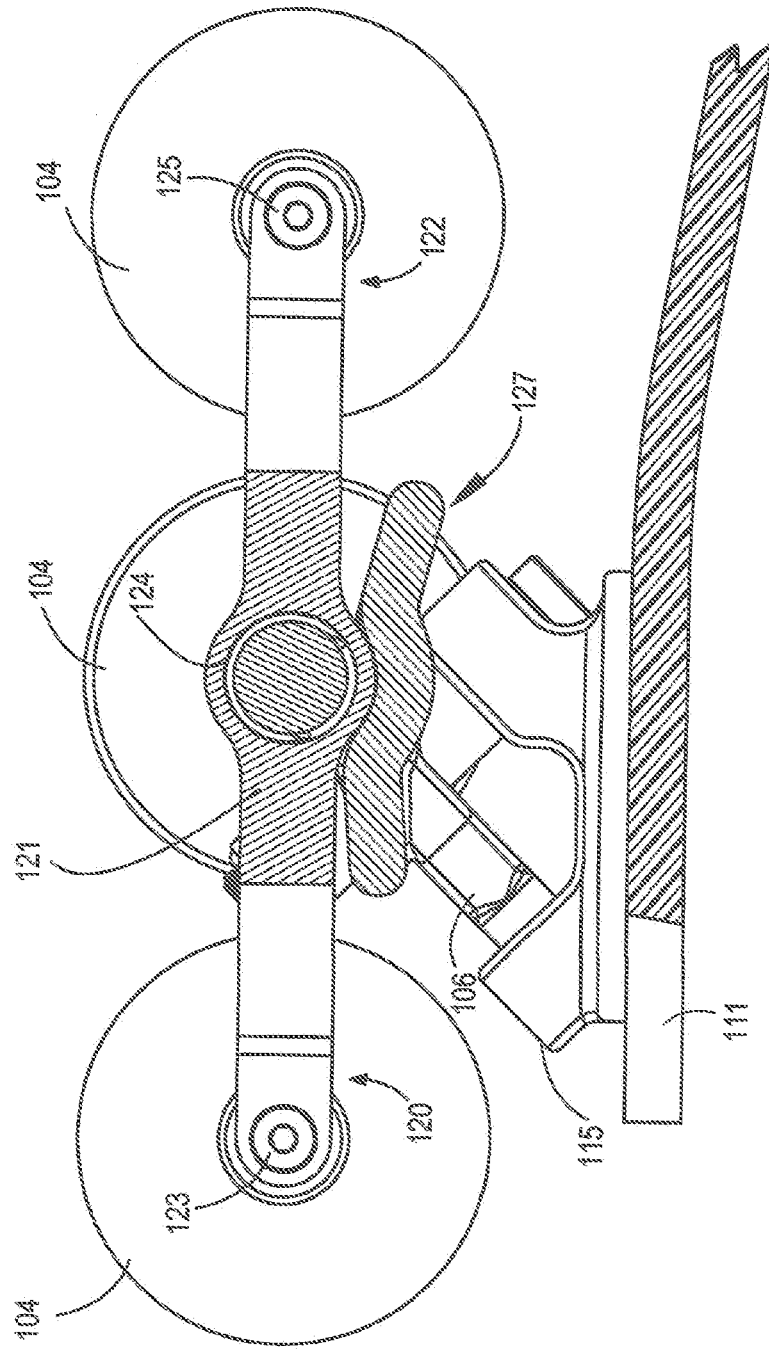

FIG. 3

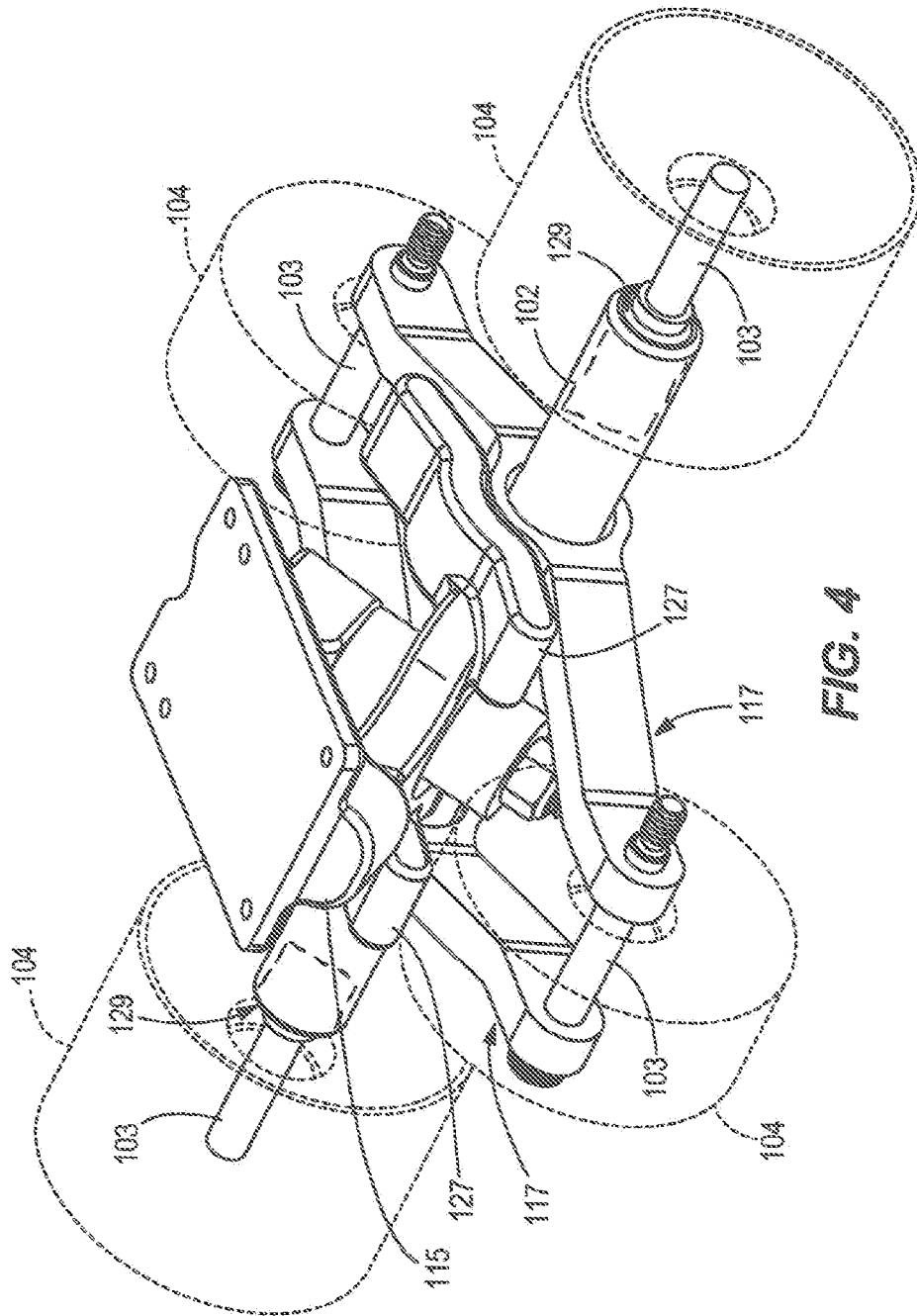
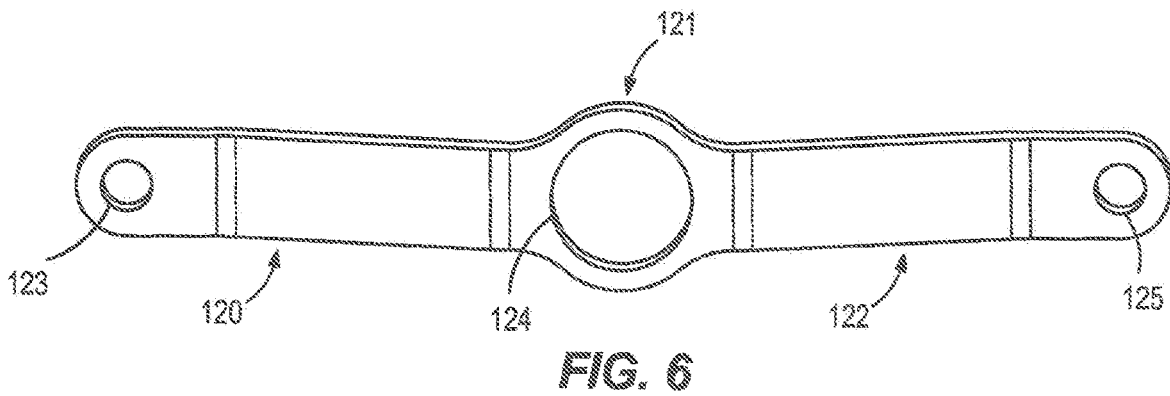
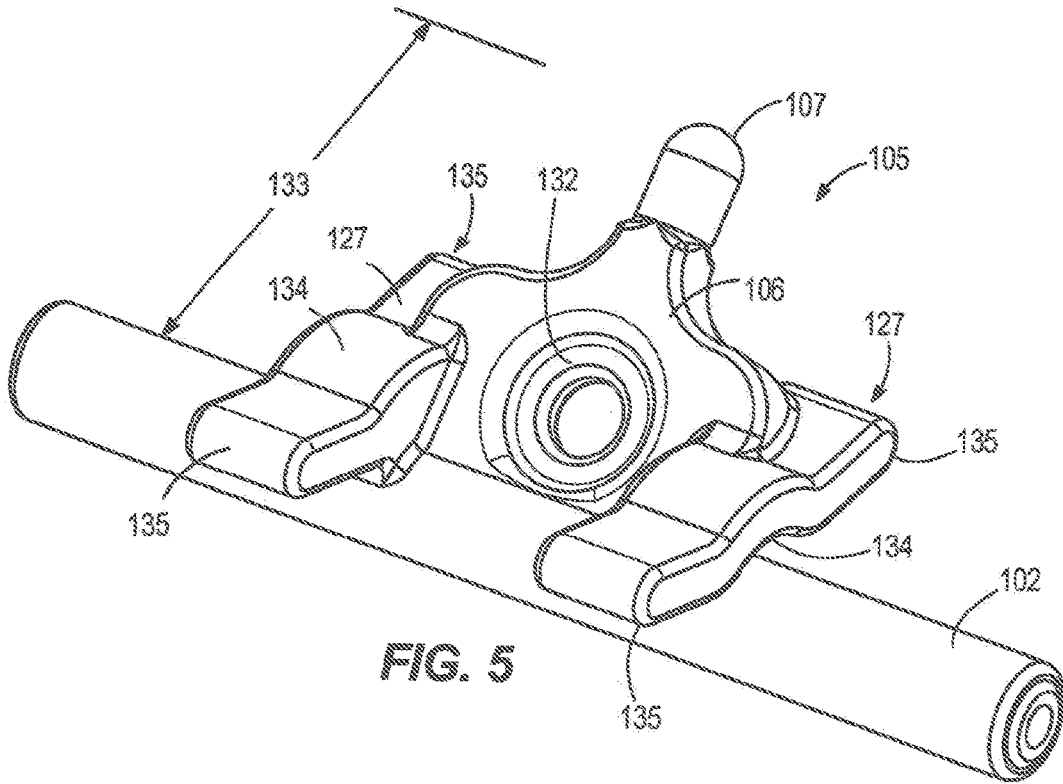
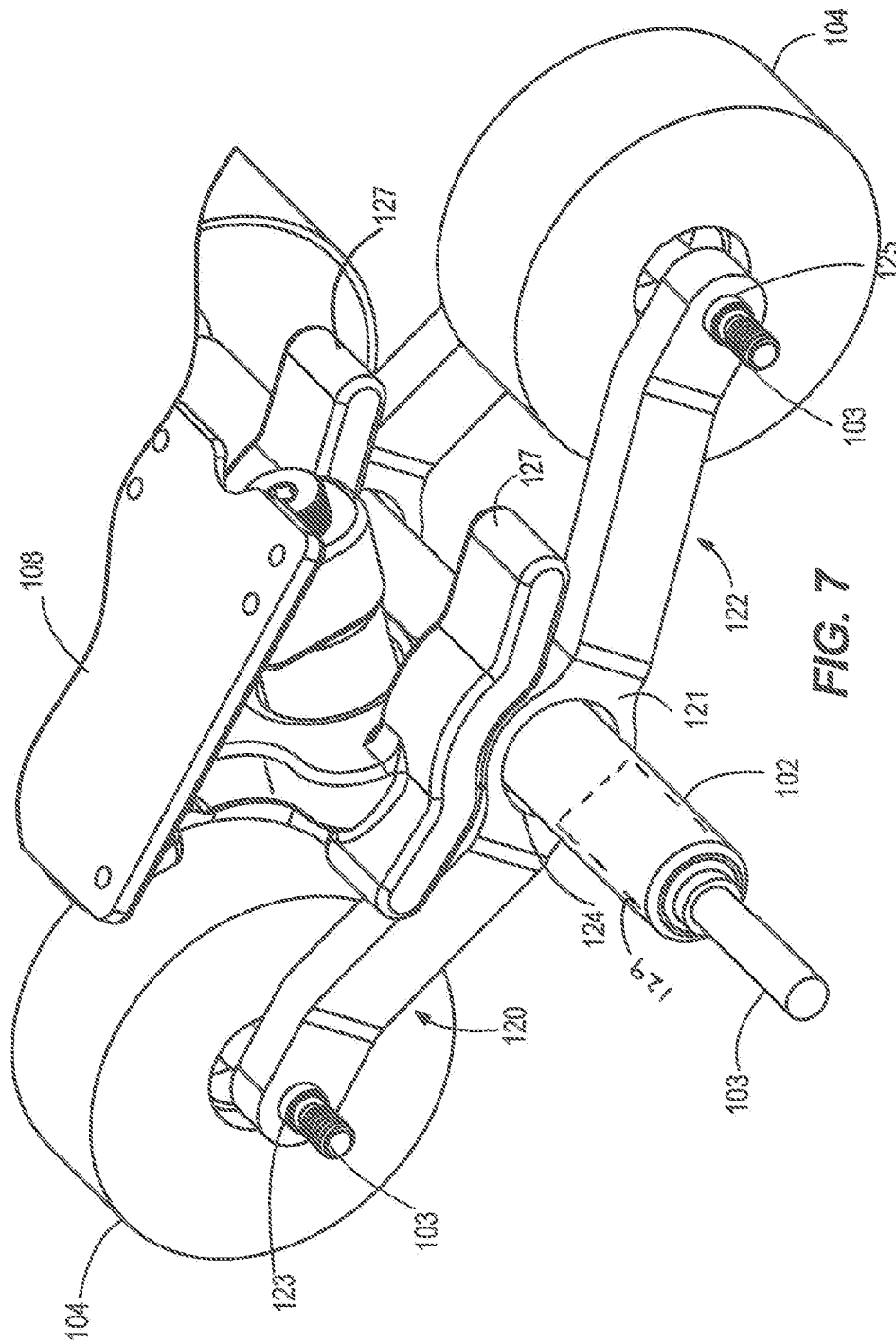

FIG. 4





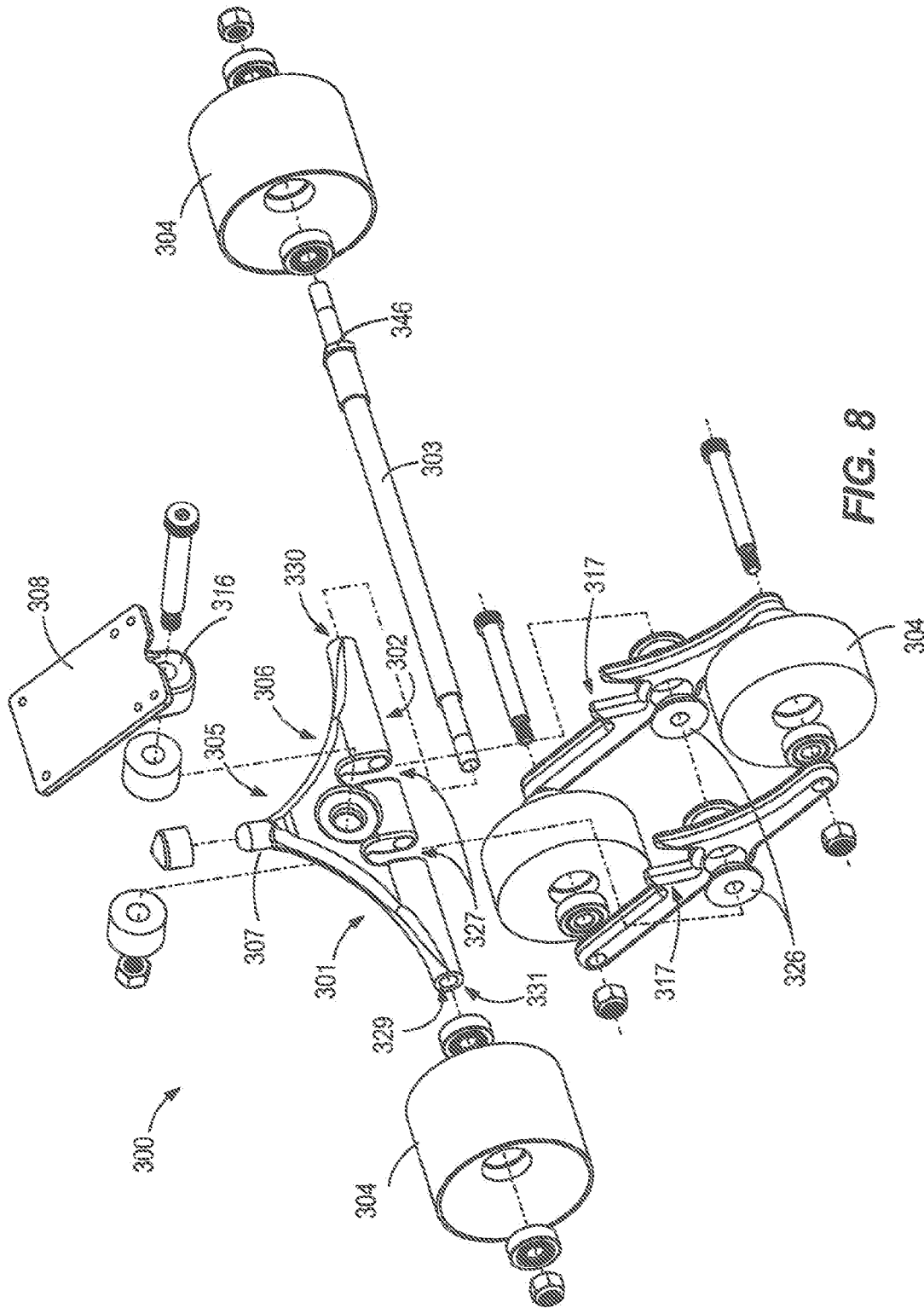

FIG. 8

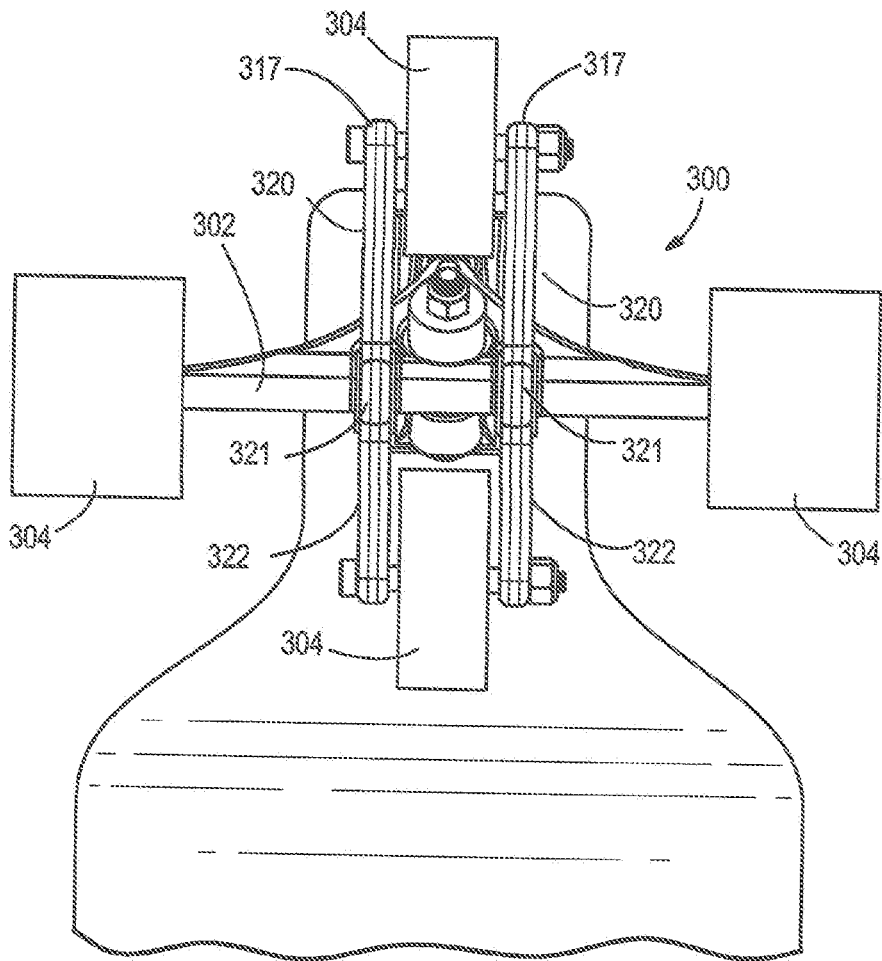

FIG. 9

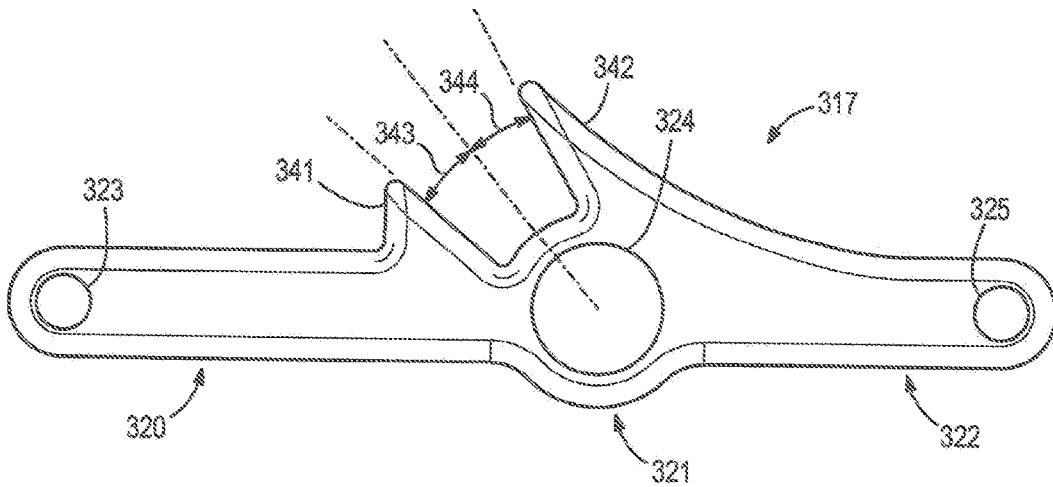

FIG. 10

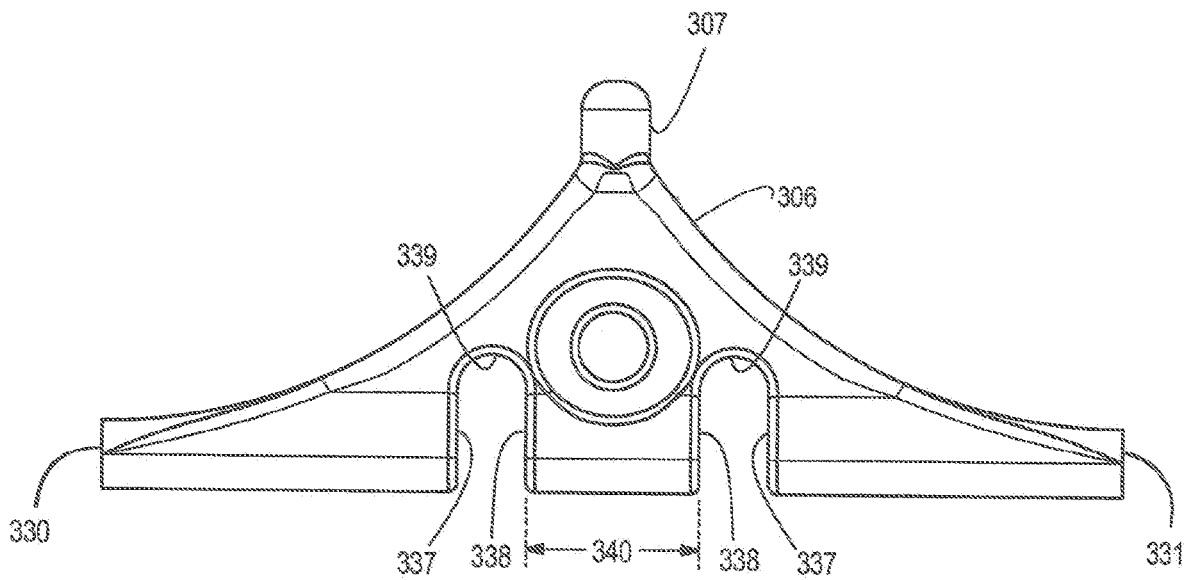

FIG. 11

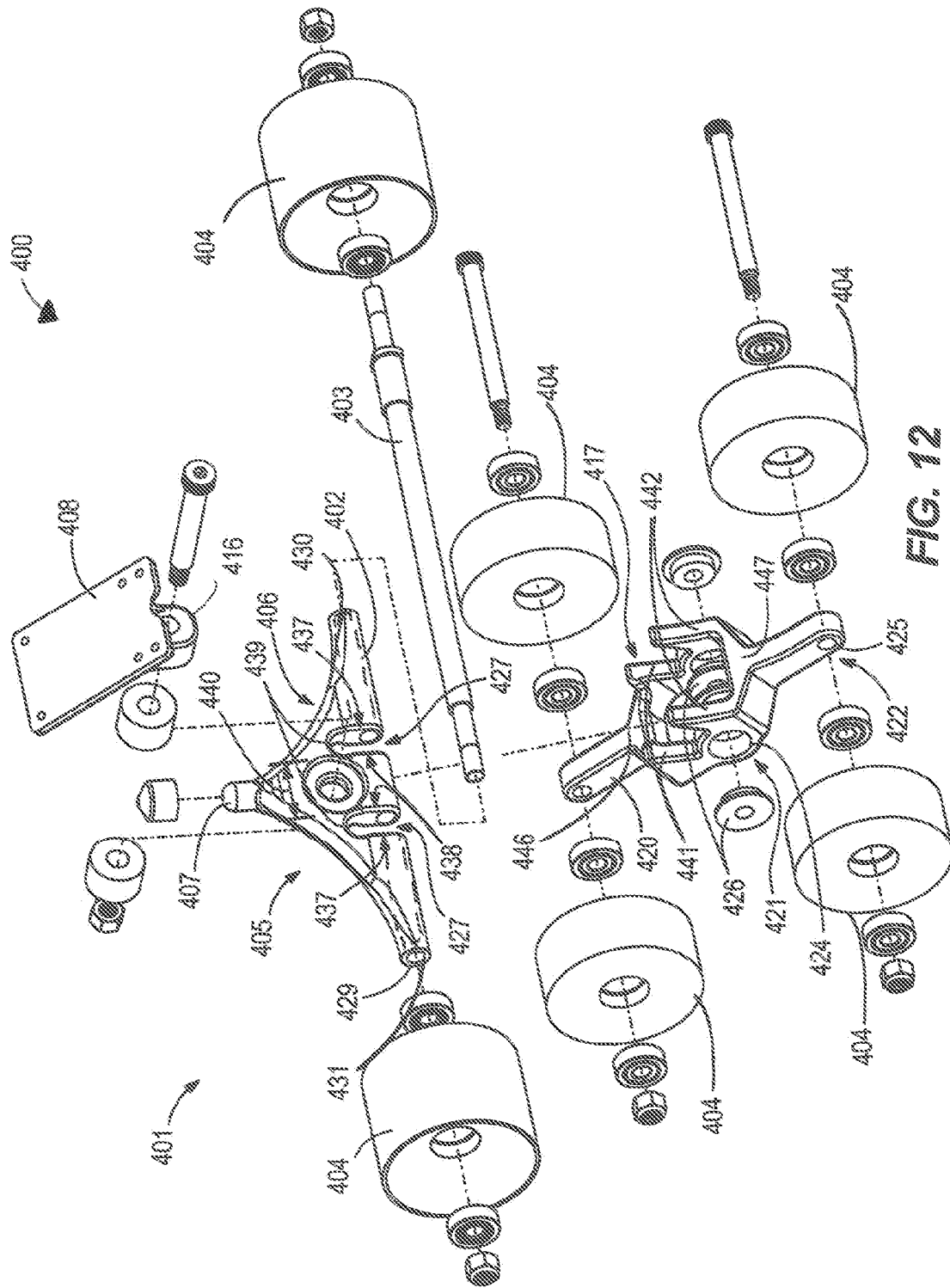

FIG. 12

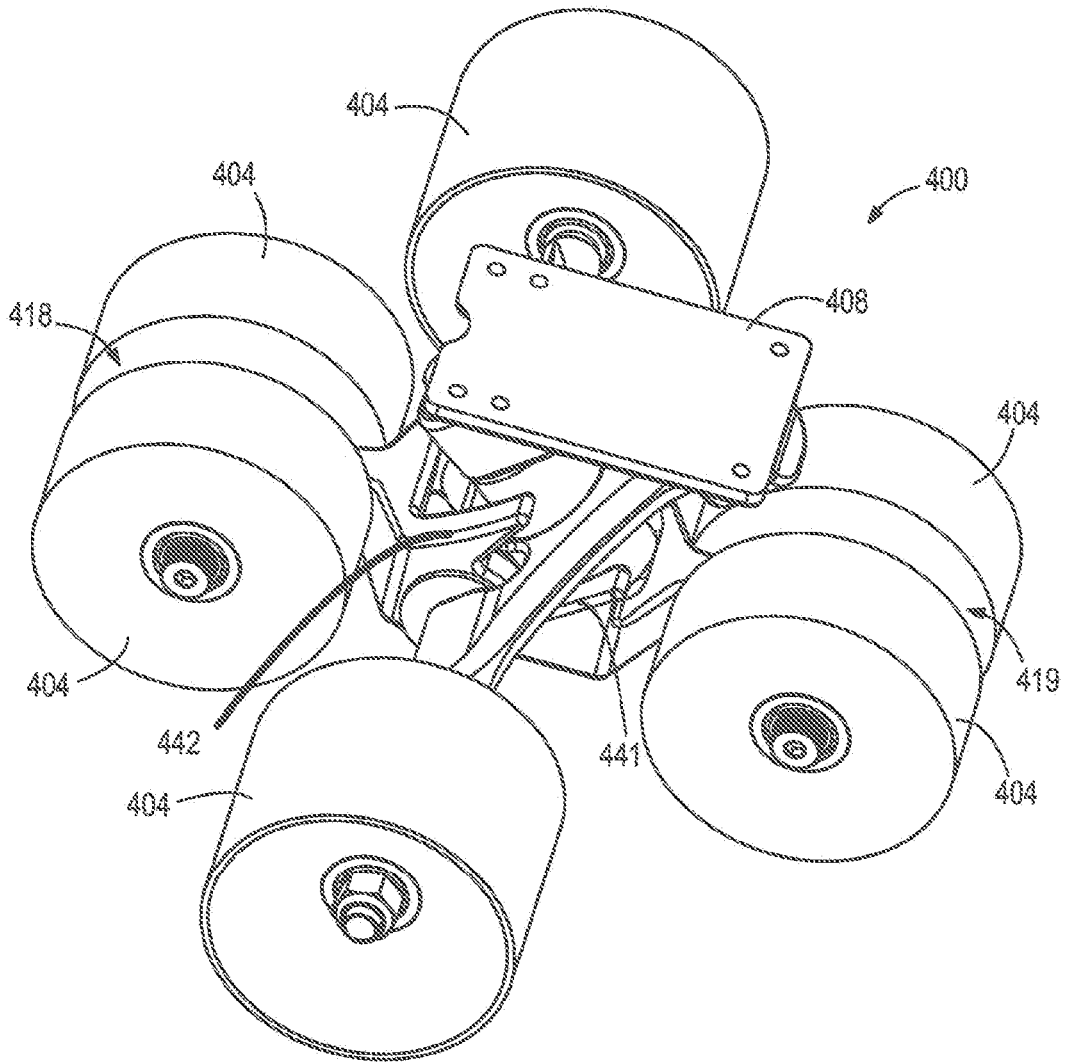

FIG. 13

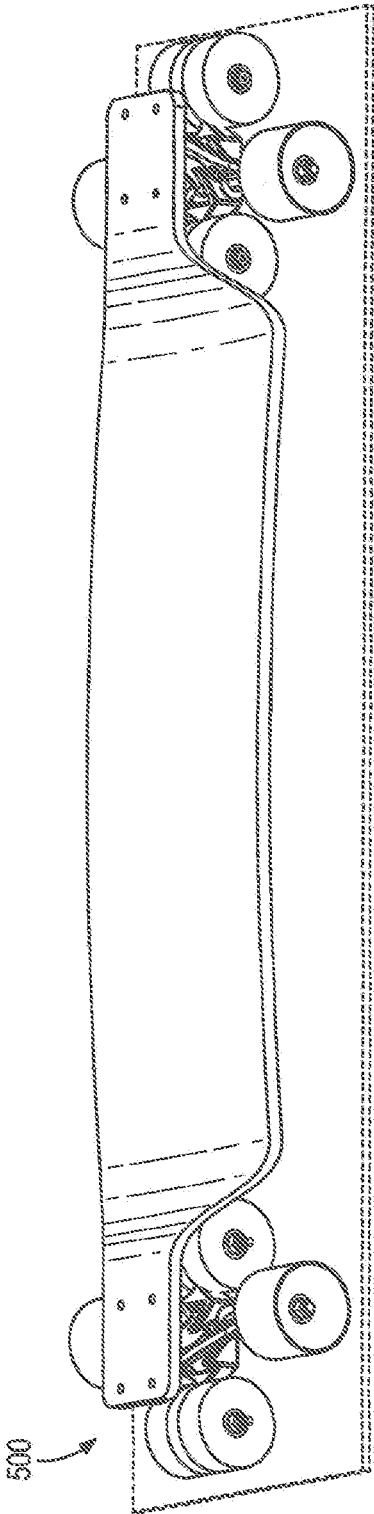

FIG. 14

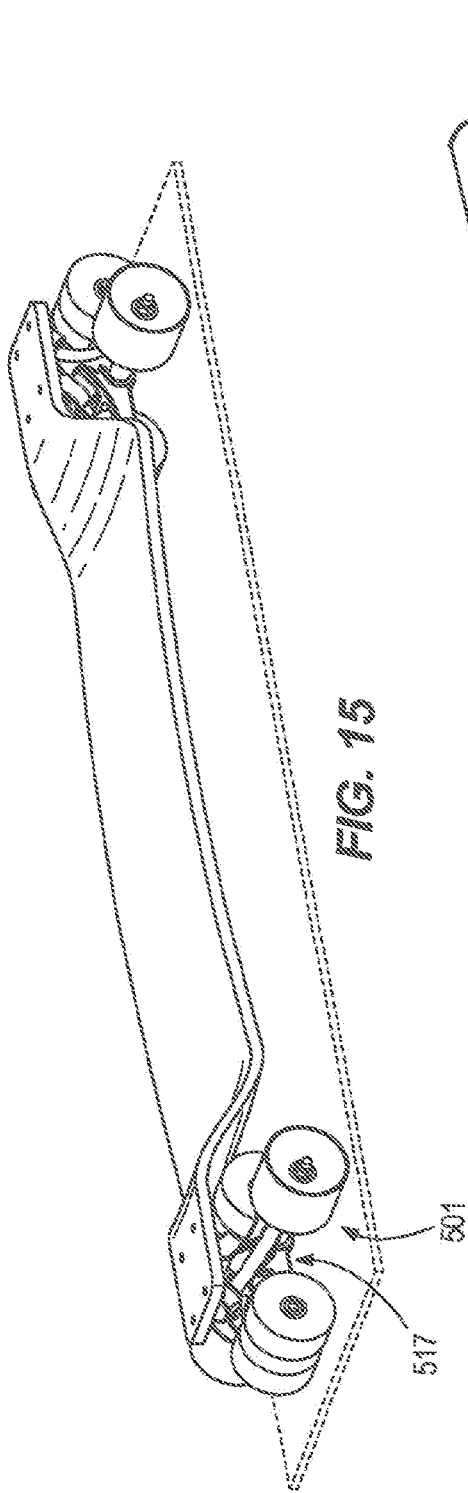

FIG. 15

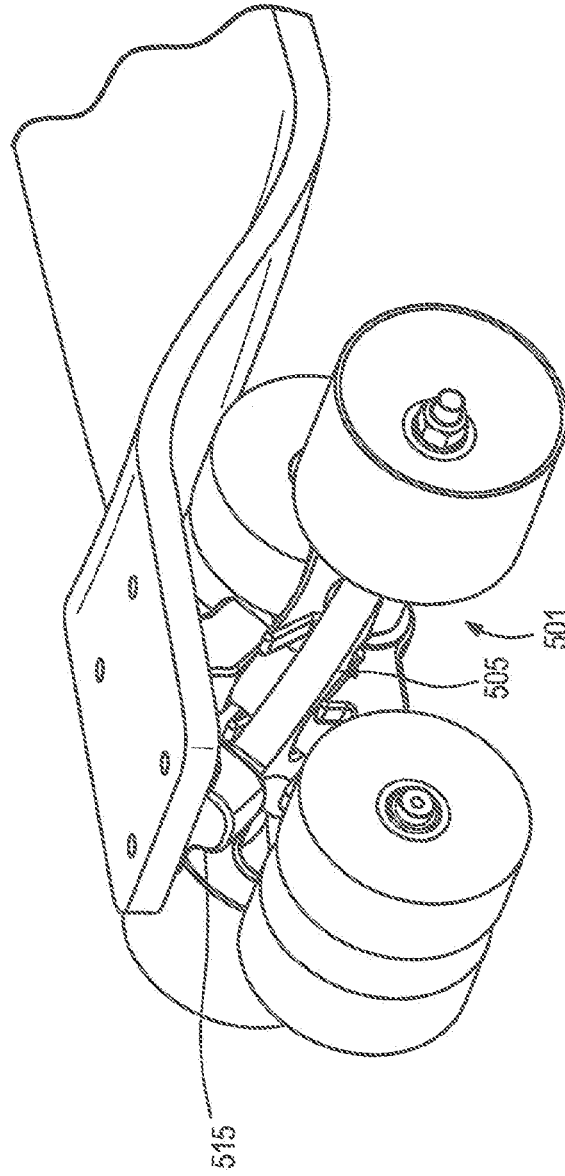
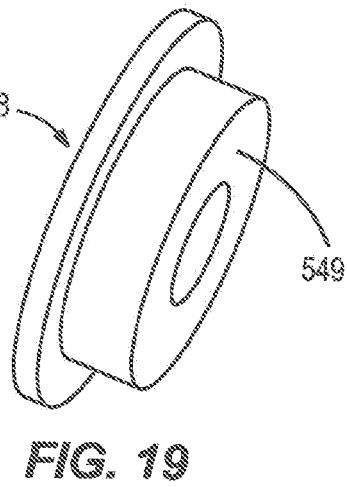
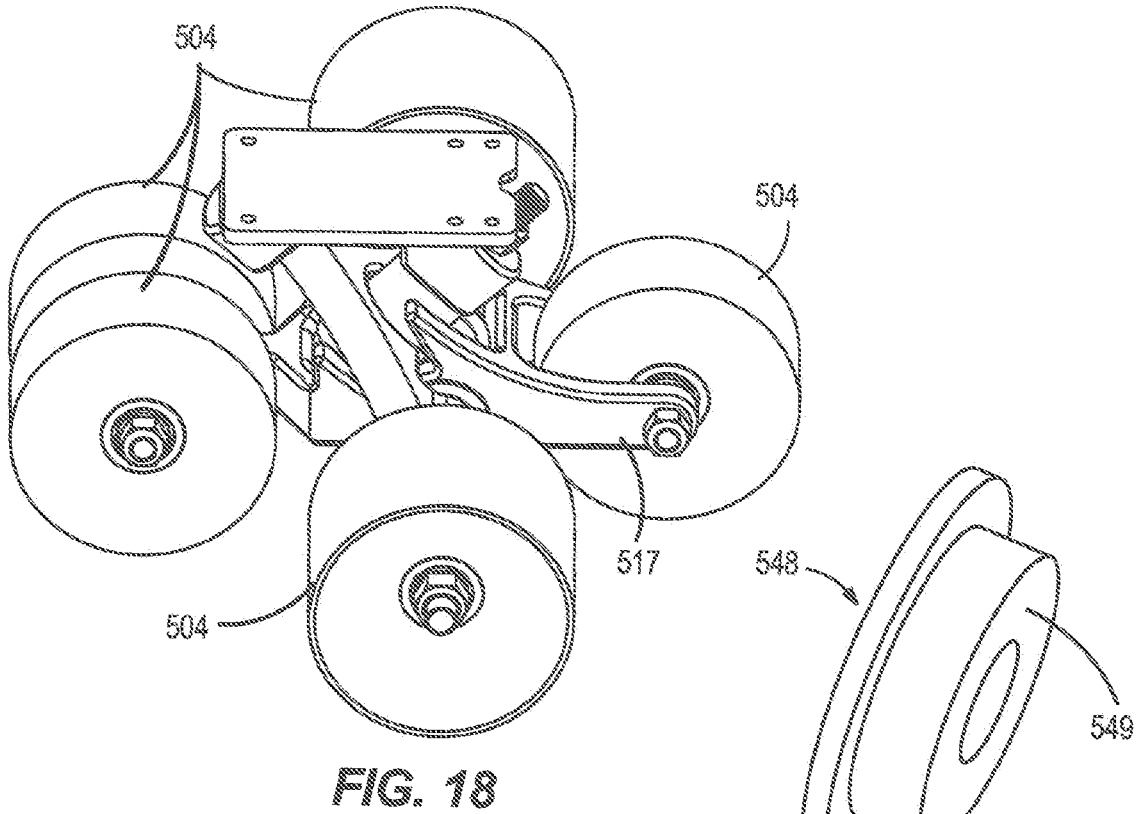
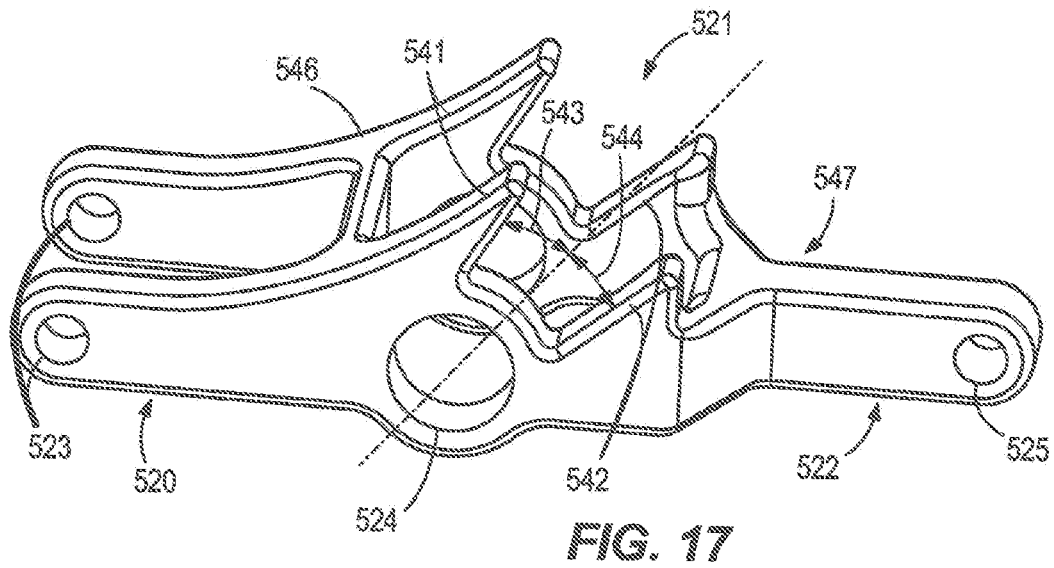

FIG. 16



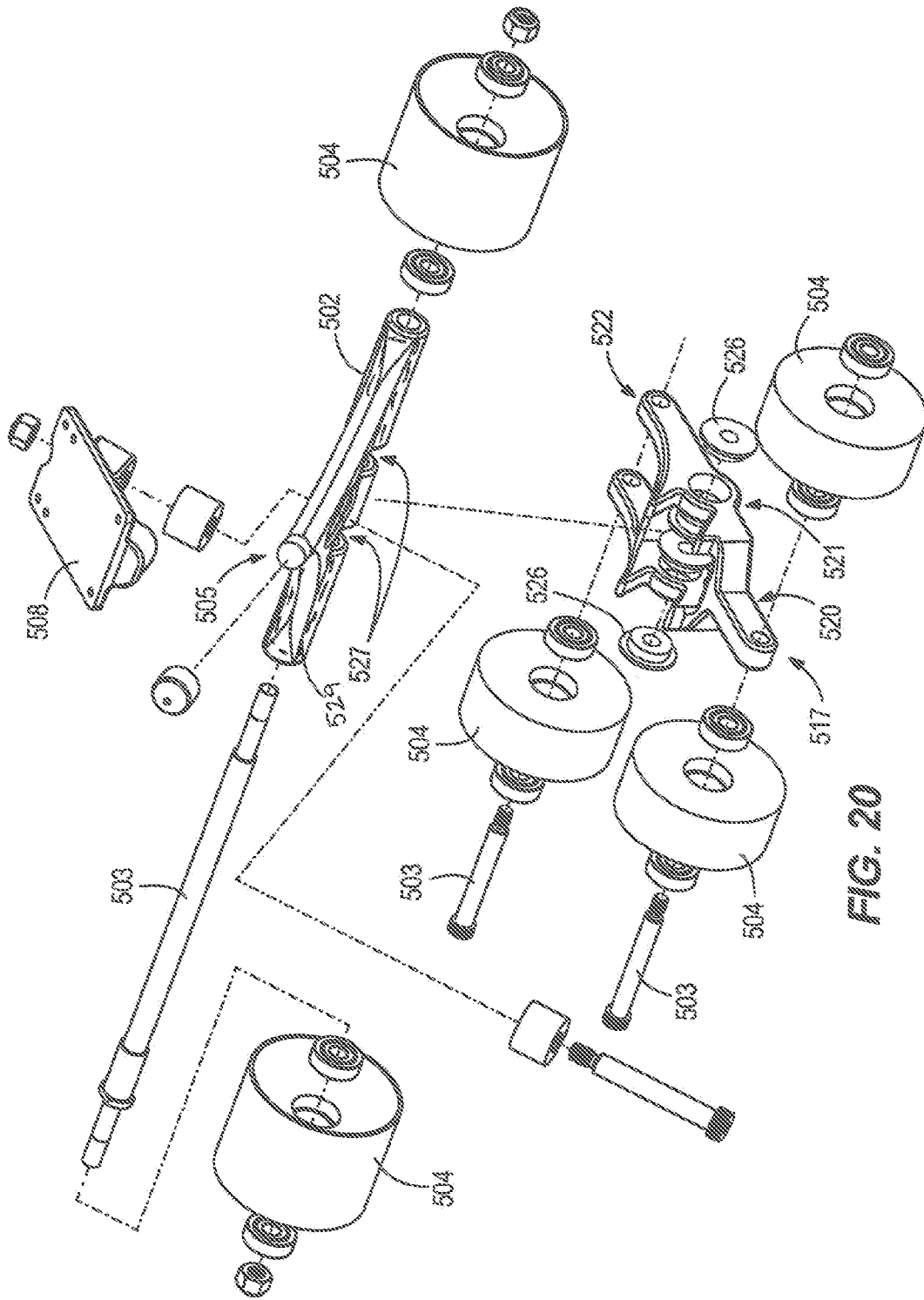
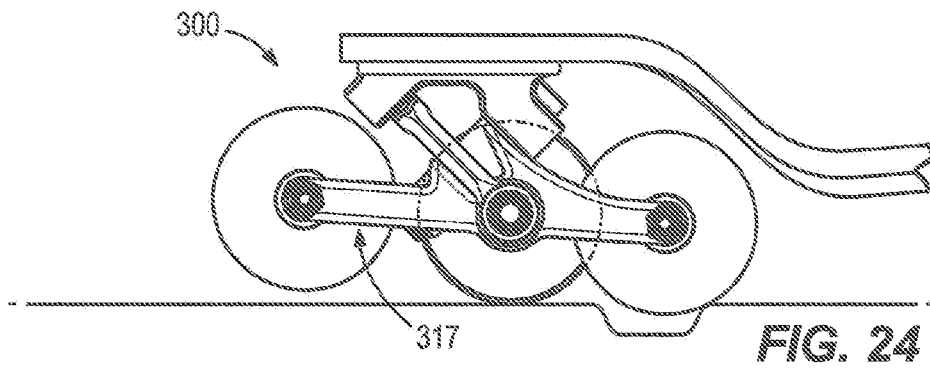
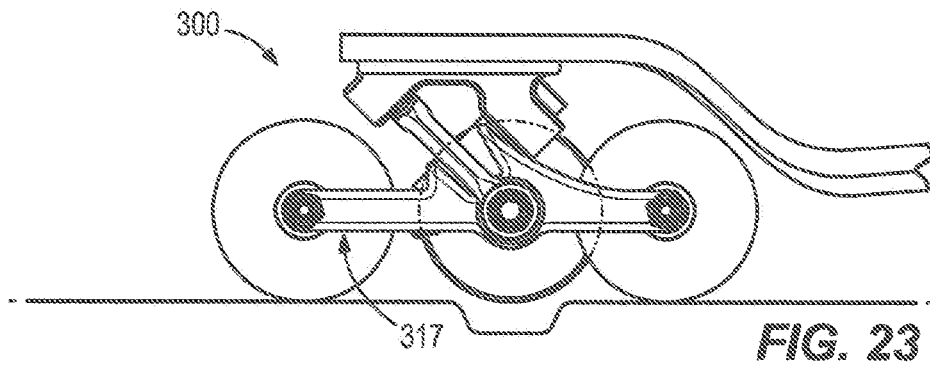
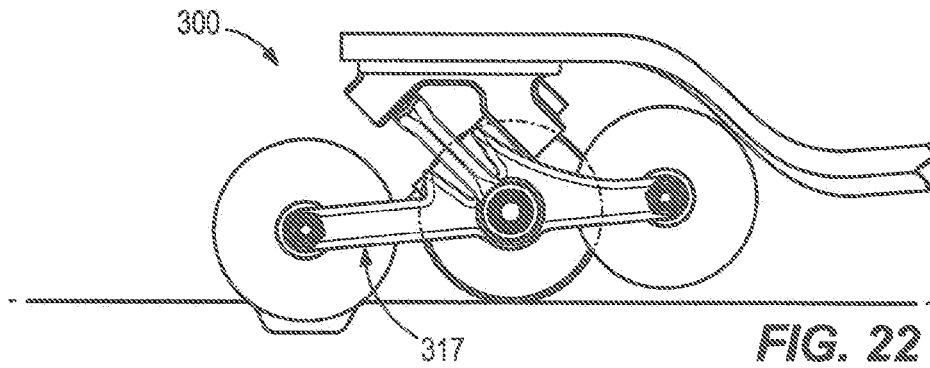
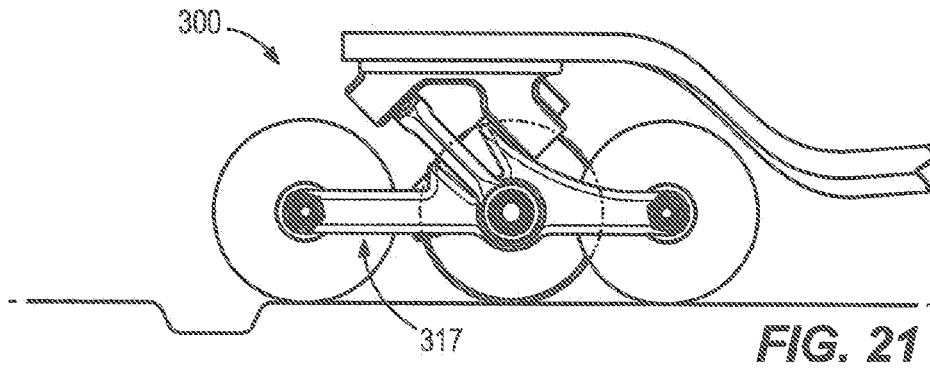

FIG. 20



1

SKATEBOARDS WITH A MULTI-WHEEL TRUCK

RELATED APPLICATION DATA

This claims the benefit of U.S. Patent Application No. 62/822,412, filed on Mar. 22, 2019 and U.S. Patent Application No. 62/880,562, filed on Jul. 30, 2019, the contents of all of which are entirely incorporated herein by reference.

TECHNICAL FIELD

This disclosure relates generally to skateboards and more particularly to a multi-wheel skateboard truck.

BACKGROUND

Individuals have ridden and used skateboards as a convenient and entertaining form of transportation. Generally, skateboards present many favorable advantages over other self-propelled transportation alternatives, as skateboards can be easily stored, picked up, and carried. However, and quite often, when users ride skateboards over cracks including (but not an exhaustive list of) contraction joints, expansion joints, control joints, and uneven surfaces, the wheels of the skateboard descend into the crack and then pop back up when the wheels of the skateboard contacts the other side of the crack. This type of interaction results in detrimental effects including, noise, shock to the rider, and handling (or control) of the skateboard. There is a need in the art for a moving wheel platform that minimizes wheel interactions with noncontinuous and uneven surfaces to enhance an individual's riding experience and satisfaction.

BRIEF DESCRIPTION OF THE DRAWINGS

FIG. 1 shows a perspective view of a moving wheel platform coupled to a skateboard deck according to one embodiment.

FIG. 2 shows a partial exploded view of the moving wheel platform of FIG. 1.

FIG. 3 shows another perspective view of a moving wheel platform coupled to a skateboard of FIG. 1.

FIG. 4 shows an assembled moving wheel platform of FIG. 2.

FIG. 5 shows a close up view of the hanger of FIG. 1.

FIG. 6 shows a close-up view of the arm of FIG. 1.

FIG. 7 shows a partial assembled view of FIG. 4.

FIG. 8 shows an exploded view of a moving wheel platform according to another embodiment.

FIG. 9 shows the assembled moving wheel platform of FIG. 8 coupled to a skateboard.

FIG. 10 shows a close-up view of the arm of FIG. 8.

FIG. 11 shows a close-up view of the hanger of FIG. 8.

FIG. 12 shows an exploded view of a moving wheel platform according to another embodiment.

FIG. 13 shows the assembled moving wheel platform of FIG. 12.

FIG. 14 shows the moving wheel platform of FIG. 12 coupled to a skateboard deck.

FIG. 15 shows a moving wheel platform coupled to a skateboard deck according to another embodiment.

FIG. 16 shows a close-up view of FIG. 15.

FIG. 17 shows an arm according to the embodiment of FIG. 15.

FIG. 18 shows the assembled view of the moving wheel platform of FIG. 15.

2

FIG. 19 shows a friction reducing element according to the embodiment of FIG. 15.

FIG. 20 shows an exploded view of the moving wheel platform of FIG. 15

5 FIGS. 21-24 shows an exemplary motion analysis of the moving wheel platform of FIG. 8.

DESCRIPTION

10 The invention presented herein is directed to moving-wheel platforms that are capable of tempering negative (or unwanted) feedback experienced by a user when maneuvering over uneven surfaces, such as sidewalk cracks. Many of the moving-wheel platform embodiments presented herein, can be configured for use in skateboard or longboard applications (in the form of a truck). However, in alternative 15 embodiments, the moving wheel platforms can be adapted for use in wheelbarrows, industrial carts, industrial dollies, commercial carts, commercial dollies, hand trucks, and stack trucks applications.

The skateboard or longboard can comprise a series of trucks having arms, axles and wheels arranged in such a manner that at least two wheels are in contact with the ground surface at any given moment, while another wheel of the truck is either suspended or submerged into a crack or voided space, when applicable. The truck is further configured to prevent the wheels of the truck from contacting or engaging the bottom of the skateboard or longboard when a sudden shift in the skateboard's center of mass occurs. This is at least in part accomplished by rotation inhibiting structures.

The term or phrase "connect", "connected", "connects", "connecting" used herein can be defined as joining two or more elements together, mechanically or otherwise. Connecting (whether mechanical or otherwise) can be for any length of time, e.g. permanent or semi-permanent or only for an instant.

The term or phrase "link", "linked", "links", "linking" used herein can be defined as a relationship between two or more elements where at least one elements affects another element. Linking (whether mechanical or otherwise) can be for any length of time, e.g. permanent or semi-permanent or only for an instant.

The term or phrase "secure", "secured", "secures", "securing" used herein can be defined as fixing or fastening (one or more elements) firmly so that it cannot be moved or become loose. Securing (whether mechanical or otherwise) can be for any length of time, e.g. permanent or semi-permanent or only for an instant.

The term or phrase "width" or "width of the elongated body" used herein is measured in a direction extending from a first end of the elongated body to a second end of the elongated body (or along the longitudinal axis of the elongated body), which is distal from the first end.

The term or phrase "couple", "coupled", "couples", and "coupling" used herein can be defined as connecting two or more elements, mechanically or otherwise. Coupling (whether mechanical or otherwise) can be for any length of time, e.g. permanent or semi-permanent or only for an instant. Mechanical coupling and the like should be broadly understood and include mechanical coupling of all types. The absence of the word "removably", "removable," and the like near the word "coupled," and the like does not mean that the coupling, in question is or is not removable.

65 The term or phrase "skateboard" or "longboard" used herein can be defined by four distinct portions. A top portion of the skateboard is defined as the portion of a deck the user

stands on. A bottom portion of the skateboard is defined as the portion opposite the top portion. A stance of the right footed user by convention is defined as the left foot being forward of the right foot. A front portion of the skateboard is defined as being proximal to the left foot of the user. A back portion of the skateboard is defined as being proximal with the right foot of the user. A forward direction is defined as the direction when the right foot of the user pushes backwards on a ground surface to make the skateboard move in the opposite direction.

The terms “first,” “second,” “third,” “fourth,” and the like in the description and in the claims, if any, are used for distinguishing between similar elements and not necessarily for describing a particular sequential or chronological order. It is to be understood that the terms so used are interchangeable under appropriate circumstances such that the embodiments described herein are, for example, capable of operation in sequences other than those illustrated or otherwise described herein. Furthermore, the terms “include,” and “have,” and any variations thereof, are intended to cover a non-exclusive inclusion, such that a process, method, system, article, device, or apparatus that comprises a list of elements is not necessarily limited to those elements but may include other elements not expressly listed or inherent to such process, method, system, article, device, or apparatus.

The terms “left,” “right,” “front,” “back,” “top,” “bottom,” “over,” “under,” and the like in the description and in the claims, if any, are used for descriptive purposes and not necessarily for describing permanent relative positions. It is to be understood that the terms so used are interchangeable under appropriate circumstances such that the embodiments of the apparatus, methods, and/or articles of manufacture described herein are, for example, capable of operation in other orientations than those illustrated or otherwise described herein.

“A,” “an,” “the,” “at least one,” and “one or more” are used interchangeably to indicate that at least one of the item is present; a plurality of such items may be present unless the context clearly indicates otherwise. All numerical values of parameters (e.g., of quantities or conditions) in this specification, including the appended claims, are to be understood as being modified in all instances by the term “about” whether or not “about” actually appears before the numerical value. “About” indicates that the stated numerical value allows some slight imprecision (with some approach to exactness in the value; about or reasonably close to the value; nearly). If the imprecision provided by “about” is not otherwise understood in the art with this ordinary meaning, then “about” as used herein indicates at least variations that may arise from ordinary methods of measuring and using such parameters. In addition, disclosure of ranges includes disclosure of all values and further divided ranges within the entire range. Each value within a range and the endpoints of a range are hereby all disclosed as separate embodiment. The terms “comprises,” “comprising,” “including,” and “having,” are inclusive and therefore specify the presence of stated items, but do not preclude the presence of other items. As used in this specification, the term “or” includes any and all combinations of one or more of the listed items. When the terms first, second, third, etc. are used to differentiate various items from each other, these designations are merely for convenience and do not limit the items.

In many examples as used herein, the term “approximately” can be used when comparing one or more values, ranges of values, relationships (e.g., position, orientation, etc.) or parameters (e.g., velocity, acceleration, mass, tem-

perature, spin rate, spin direction, etc.) to one or more other values, ranges of values, or parameters, respectively, and/or when describing a condition (e.g., with respect to time), such as, for example, a condition of remaining constant with respect to time. In these examples, use of the word “approximately” can mean that the value(s), range(s) of values, relationship(s), parameter(s), or condition(s) are within $\pm 0.5\%$, $\pm 1.0\%$, $\pm 2.0\%$, $\pm 3.0\%$, $\pm 5.0\%$, and/or $\pm 10.0\%$ of the related value(s), range(s) of values, relationship(s), parameter(s), or condition(s), as applicable.

Before any embodiments of the disclosure are explained in detail, it is to be understood that the disclosure is not limited in its application to the details of construction and the arrangement of components set forth in the following description or illustrated in the following drawings. The disclosure is capable of other embodiments and of being practiced or of being carried out in various ways.

Presented herein are skateboards or longboards comprising a series of trucks (skateboard **111**, **511**). The moving wheel platforms described herein can be configured for use in skateboard or longboard applications in the form of a truck (the truck **100**, **200**, **300**, **400**, **500**). FIGS. 1-20 illustrates multiple truck embodiments that enables an apparatus to glide, Hoover, and/or reduce adverse interactions between the skateboard truck and ground surface when the skateboard is moving over uneven surfaces, cracks, or joints. The various trucks (**100**, **200**, **300**, **400** or **500**) comprises: a hanger having an elongated body, a pivot saddle protruding from the elongated body, one or more axle(s) extending through or partially through the elongated body, one or more arm(s) rotatably coupled (or connected) to the elongated body, and one or more rotation inhibiting structure(s) governing the rotation of the one or more arm(s). Further, a variety of wheel arrangements and rotation inhibiting structures are presented that cooperate together to approach voids present along riding surfaces differently. The various locations, arrangements, and configurations of the wheels, arms, and rotation inhibiting structures prevent the wheels from interacting, overextending and/or engaging the bottom surface of a skateboard or longboard.

I. Components of the Skateboard Truck

1. Hanger

In many of the exemplary skateboard truck embodiments, the truck comprises a hanger. The hanger generally comprises an elongated body; a pivot saddle protruding from the elongated body; a void (or bore) extending longitudinally through the elongated body; one or more arms pivotably (and/or removably) engaged to the hanger; and one or more rotation-inhibiting structure(s) configured to limit over rotation of the one or more arm(s). In many embodiments, the hanger is configured to be coupled to a baseplate.

The baseplate, in return, can be affixed to the bottom surface of the skateboard or longboard. As the hanger and the baseplate are assembled to one another, a linkage is formed that enables the hanger to become a base or foundation piece that directly or indirectly connects, links, or secures many of the undermentioned components together.

2. Elongated Body

Generally, in many embodiments, a portion of the hanger comprises an elongated body. The elongated body of the hanger can be cylindrical (“elongated cylindrical body”) and/or tubular (“elongated tubular body”). FIG. 2 illustrates a portion of an elongated body having a cylindrical portion. In this embodiment, the elongated cylindrical body can have a constant radius that extends in a first end to a second end

direction of the elongated cylindrical body (i.e. along the longitudinal direction of the elongated body). The constant radius can range between 0.1 inch to 1 inch. In many embodiments, the constant radius can be 0.1-inch, 0.2-inch, 0.3-inch, 0.4-inch, 0.5-inch, 0.6-inch, 0.7-inch, 0.8-inch, 0.9-inch, or 1.0-inch. In other embodiments, the radius can be approximately between 0.1 inch-0.2 inch, 0.2 inch -0.3 inch, 0.3 inch-0.4 inch, 0.4 inch-0.5 inch, 0.5 inch-0.6 inch, 0.6 inch-0.7 inch, 0.7 inch-0.8 inch, 0.8 inch-0.9 inch, or 0.9 inch-1.0 inch. The radius of the elongated cylindrical body can vary to alter the mass properties of the skateboard truck.

As previously mentioned, the elongated body can be tubular ("elongated tubular body"). In many embodiments, the elongated tubular body comprises an inner diameter and an outer diameter throughout the entire width of the hanger (see FIG. 8). FIG. 8 illustrates an elongated tubular member defined by an inner diameter D1 and an outer diameter D2. The inner diameter of the elongated tubular body can range between 0.01 inch to 0.55 inch.

In specific embodiments, the inner diameter D1 of the elongated tubular body can be 0.01 inch, 0.03 inch, 0.05 inch, 0.07 inch, 0.09 inch, 0.11 inch, 0.13 inch, 0.15 inch, 0.17 inch, 0.19 inch, 0.21 inch, 0.23 inch, 0.25 inch, 0.27 inch, 0.29 inch, 0.31 inch, 0.33 inch, 0.35 inch, 0.37 inch, 0.39 inch, 0.41 inch, 0.43 inch, 0.45 inch, 0.47 inch, 0.49 inch, 0.51 inch, 0.53 inch, or 0.55 inch. The outer diameter D2 can range between 0.1 inch to 1.0 inch. Specifically, the outer diameter of the elongated tubular body can be 0.1-inch, 0.2-inch, 0.3-inch, 0.4-inch, 0.5-inch, 0.6-inch, 0.7-inch, 0.8-inch, 0.9 inch, or 1.0 inch, or combinations thereof. In other embodiments, the outer diameter D2 can range between 0.1 inch-0.2 inch, 0.2 inch-0.3 inch, 0.3 inch-0.4 inch, 0.4 inch-0.5 inch, 0.5 inch-0.6 inch, 0.6 inch-0.7 inch, 0.7 inch-0.8 inch, 0.8 inch-0.9 inch, or 0.9 inch-1.0 inch.

The material of the elongated body can be constructed from any material used to construct a conventional skateboard truck. The elongated body of the hanger can be made from any one or combination of the following: 8620 alloy steel, S25C steel, carbon steel, maraging steel, 17-4 stainless steel, 1380 stainless steel, 303 stainless steel, stainless steel alloy, brushed steel, tungsten, titanium, titanium alloy, aluminum, aluminum alloy, aluminum 3003, aluminum 5052, aluminum 6061, aluminum 7075, Aluminum A356, ADC-12, or any other metal or plastic suitable for creating an elongated body. The material of the elongated body can vary based upon the intended use and/or weight of the hanger.

The elongated body of the hanger may vary in width to accommodate (or compliment) the width of the skateboard deck or a particular apparatus. In many embodiments, the width of the elongated body can range between approximately 5 inches to approximately 9 inches. In other embodiments, the width of the elongated body can be approximately between 5 inches-6 inches, 6 inches-7 inches, 7 inches-8 inches, or 8 inches-9 inches. In further embodiments, the width of the elongated body can be approximately 5 inches, 6 inches, 7 inches, 8 inches, 9 inches, or other suitable widths that enables a proper relationship between the width of the skateboard and the width of the hanger.

In many embodiments, in a widthwise direction, a portion of the elongated body forms a void. An exemplary embodiment of the elongated body forming a void is illustrated in FIGS. 2 and 5. FIGS. 2 and 5 illustrates a void formed on each corresponding end (first end and second end) of the elongated body. Each void extends in a widthwise direction between approximately 1% and approximately 50% of the

total width of the hanger. In other words, a portion of the elongated body surrounds a void as further illustrated by FIGS. 1-4, 9, and 10.

Each void of the elongated body can extend along the width direction of the elongated body between approximately 1% and 50%. Specifically, in many embodiments, the void can extend approximately between 1%-5%, 5%-10%, 10%-15%, 15%-20%, 20%-25%, 25%-30%, 30%-35%, 35%-40%, 40%-45%, or 45%-50% of the elongated body width. In alternative embodiments, as illustrated in FIGS. 8-19, the hanger can form a bore that extends entirely through the elongated body. The void or bore enables one or more axle(s) to become rigidly attached to the elongated body.

3. Axle(s)

The truck further comprises at least one axle. The one or more axles may extend either entirely through the elongated body of the hanger (if the elongated body forms a bore) or partially through the elongated body (if the elongated body forms a void). In many embodiments, if the bore extends entirely through the elongated body, then only one axle is needed. If a portion of the hanger is solid, then a void exists on the distal ends of the elongated body and two different axles extend through and out the ends of the elongated body. The void(s) can extend from each end of the elongated body into a percentage (less than approximately 50%) of the elongated body width, as a solid section of the elongated body exists between voids.

4. Wheels

The trucks further comprise at least two wheels. In many embodiments, one or more axles are configured to receive one or more wheels. Each of the one or more wheels may be characterized by a diameter (wheel diameter), a durometer (wheel durometer), and a material (wheel material). In many embodiments, the truck can have two or more wheels, three or more wheels, four or more wheels, five or more wheels, or six or more wheels. For further example, in many embodiments, the skateboard truck can have two wheels, three wheels, four wheels, five wheels, six wheels, or seven wheels.

In many embodiments, the diameter of the one or more wheel(s) ranges between 40 mm and 76 mm. In other embodiments, the wheel diameter can range between 40 mm-42 mm, 42 mm-44 mm, 44 mm-46 mm, 46 mm-48 mm, 48 mm-50 mm, 50 mm-52 mm, 52 mm-54 mm, 54 mm-56 mm, 56 mm-58 mm, 58 mm-60 mm, 60 mm-62 mm, 62 mm-64 mm, 64 mm-66 mm, 66 mm-68 mm, 68 mm-70 mm, 70 mm-72 mm, 72 mm-74 mm, or 74 mm-76 mm. In some embodiments, the wheel diameter of the one or more wheels can be 40 mm, 41 mm, 42 mm, 43 mm, 44 mm, 45 mm, 46 mm, 47 mm, 48 mm, 49 mm, 50 mm, 51 mm, 52 mm, 53 mm, 54 mm, 55 mm, 56 mm, 57 mm, 58 mm, 59 mm, 60 mm, 61 mm, 62 mm, 63 mm, 64 mm, 65 mm, 66 mm, 67 mm, 68 mm, 69 mm, 70 mm, 71 mm, 72 mm, 73 mm, 74 mm, 75 mm, or 76 mm.

One or more wheel(s) may have an equivalent and/or similar diameter with respect to another wheel, two or more wheels, three or more wheels, four or more wheels, or five or more wheels. In alternative embodiments, one or more wheels may have a different wheel diameter with respect to another wheel, two or more wheels, three or more wheels, four or more wheels, or five or more wheels.

In many embodiments, the wheel durometer can vary based upon the intended use of the wheel and desired gripping ability with the ground surface. For example, if the user (or individual) requires wheels that provide enough grip to maneuver over rough surfaces, sidewalk contraction

joints, cracks, pebbles, rocks, etc., then the durometer of the plurality of wheels may range between approximately 78 a-98 a. In other embodiments, the wheel durometer value can be between approximately 78 a-80 a, 80 a-82 a, 82 a-84 a, 84 a-86 a, 86 a-88 a, 88 a-90 a, 90 a-92 a, 92 a-94 a, 94 a-96 a, or 96 a-98 a. In some embodiments, the wheel durometer value can be 78 a, 79 a, 80 a, 81 a, 82 a, 83 a, 84 a, 85 a, 86 a, 87 a, 88 a, 89 a, 90 a, 91 a, 92 a, 93 a, 94 a, 95 a, 96 a, 97 a, or 98 a. To achieve a desired wheel durometer, the plurality of wheels can be formed from various plastic or plastic polyurethane materials.

5. Wheel Bearings

Each of the plurality of wheels further includes a wheel bearing set. In many of the illustrative embodiments, a center of each of the plurality of wheels forms a cutout portion to accommodate the wheel bearing set. The wheel bearing set reduces or eliminates friction between the plurality of wheels and the axle the wheel rotates about. The cut-out portion can be substantially round or circular, however, in alternative embodiments the cut out-portion can be any geometry that permits rotation. In many exemplary embodiments, the wheel bearing set can be in the form of a steel bearing set or a ceramic bearing set.

6. Pivot Saddle

In many embodiments, the hanger further comprises a pivot saddle that extends from the elongated body. The pivot saddle enables a user to alter the direction of the truck. For example, the pivot saddle provides the ability to pivot the truck in a left or right direction. The pivot saddle comprises a pivot tip and a pivot body. In general, and more preferably, the pivot saddle can be integrally connected to the elongated body and therefore formed as one component. In other embodiments, the pivot saddle and the elongated body can be formed from a similar or different material. The combination of the elongated body and pivot saddle generally outlines a triangular shape. The pivot saddle connects and engages to a base plate.

In many embodiments, the pivot saddle is centrally located along the elongated body relative to the first and second ends. In alternative embodiments, the pivot saddle can be asymmetrically positioned along the elongated body. In many embodiments, the pivot saddle can be located between approximately 20% and approximately 80% of the total width of the elongated body (measured from either the first end or the second end of the elongated body of the hanger). For example, the pivot saddle can be positioned approximately 20%, 21%, 22%, 23%, 24%, 25%, 26%, 27%, 28%, 29%, 30%, 31%, 32%, 33%, 34%, 35%, 36%, 37%, 38%, 39%, 40%, 41%, 42%, 43%, 44%, 45%, 46%, 47%, 48%, 49%, 50%, 51%, 52%, 53%, 54%, or 55% away from either the first end and/or second end of the elongated body.

In many embodiments, the pivot body alone can take the form of a substantially triangular shape, as shown in some of the below exemplary embodiments. In alternative embodiments, the pivot body can be substantially square, rectangular, curvilinear, semi-circular, parabolic, or combinations thereof.

In many embodiments, the pivot body forms a through aperture (pivot body aperture). In general, the geometry of the through aperture is circular or cylindrical. However, in other embodiments, the geometry of the through aperture can be of an oval, elliptical, round, or countersunk form.

The material of the pivot body can be constructed from any material used to construct a conventional skateboard truck. The pivot body of the pivot saddle can be made from any one or combination of the following: 8620 alloy steel,

S25C steel, carbon steel, maraging steel, 17-4 stainless steel, 1380 stainless steel, 303 stainless steel, stainless steel alloy, brushed steel, tungsten, titanium, titanium alloy, aluminum, aluminum alloy, aluminum 3003, aluminum 5052, aluminum 6061, aluminum 7075, ADC-12, Aluminum A356, or any other metal suitable for creating a pivot body. In many embodiments, the pivot body is made of aluminum 6061 or the cast equivalent. The material of the pivot body can vary based upon the intended use and/or desired weight of the pivot saddle.

The pivot tip of the pivot saddle engages a pivot cup of the base plate. Combining the pivot tip and the pivot body together forms a pivot saddle that permits the truck to maneuver in both a left and/or right direction. The pivot tip can be integrally formed to the pivot body, thereby forming a single continuous structure.

In many embodiments, the pivot tip is widest at the surface adjacent to the pivot body and as the pivot tip becomes spaced further from the adjacent surface, the pivot tip gradually tapers (i.e. decreases in width as a function of increasing distance from the adjacent surface). At the distal most point from the adjacent surface, the pivot tip is substantially pointed and/or tipped. The arrangement and interaction of the pivot saddle and pivot cup will be described in more detail below.

The material of the pivot tip can be constructed from any material used to construct a conventional skateboard truck. The pivot tip of the pivot saddle can be made from any one or combination of the following: 8620 alloy steel, S25C steel, carbon steel, maraging steel, 17-4 stainless steel, 1380 stainless steel, 303 stainless steel, stainless steel alloy, brushed steel, tungsten, titanium, titanium alloy, aluminum, aluminum alloy, aluminum 3003, aluminum 5052, aluminum 6061, aluminum 7075 ADC-12, Aluminum A356, or any metal suitable for creating a pivot tip. In many embodiments, the pivot tip can be made of aluminum 6061 or the cast equivalent. The material of the pivot tip can vary based upon the intended use and/or desired weight of the pivot saddle.

7. Base Plate

The base plate, as previously described, is configured to receive a portion of the hanger and more particularly a portion of the pivot saddle. In many embodiments, the pivot tip of the pivot saddle protrudes from the elongated body of the hanger to engage a portion of the base plate. Thereby, affixing the hanger and the base plate together. The base plate can be defined as the component of the moving wheel platform (or truck) that couples, connects, attaches, and/or links the elongated body, the plurality of wheels, and the pivot saddle to a given apparatus to create a "movable apparatus".

The base plate forms a plurality of bolt receiving ports, at least one king pin receiving port, and at least one pivot cup receiving port. These receiving ports provide receiving geometries for a plurality of bolts, a king pin, and the pivot tip of the pivot saddle, respectively. Thereby, securing the moving wheel platform or the truck to a given apparatus.

In many embodiments, the plurality of bolt receiving ports (of the base plate) are proximal to the outer periphery or outer perimeter edge of the base plate. Further, in many embodiments, the plurality of bolt receiving ports are threaded ("threaded bolt receiving ports"). The geometrical characteristics of the threaded bolt receiving ports can vary (i.e. thread type, thread count, pitch, etc.) based upon the geometrical characteristics of a corresponding fastener configured to be received within the threaded bolt receiving ports.

For example, and by way of nonlimiting examples, the base plate can have two bolt receiving ports, three bolt receiving ports, four bolt receiving ports, five bolt receiving ports, six bolt receiving ports, or seven bolt receiving ports. As will be seen and further described below, the base plate can comprise at least four bolt receiving ports. This provides enough structural rigidity to affix the base plate to a given apparatus (i.e. affixing a skateboard truck to a skateboard deck).

The king pin receiving aperture (of the base plate) can be centrally located on the base plate with respect to the perimeter walls of the base plate. In many embodiments, the king pin receiving aperture may or may not be threaded. The geometrical characteristics of the king pin receiving aperture can vary (i.e. thread type, thread count, pitch, etc.) based upon the type and geometry of the king pin. As will be seen and further described in the below embodiments, the king pin receiving aperture can be located forward of the base plate's pivot cup. In many embodiments, the king pin can be a hollow screw that connects the elongated hollow body and the pivot saddle together (at the aperture of the pivot body) to the base plate. This arrangement couples the elongated hollow body and pivot saddle to the base plate.

The material of the base plate can be constructed from any material used to construct a conventional skateboard truck. The base plate can be made from any one or combination of the following: 8620 alloy steel, S25C steel, carbon steel, maraging steel, 17-4 stainless steel, 1380 stainless steel, 303 stainless steel, stainless steel alloy, brushed steel, tungsten, titanium, titanium alloy, aluminum, aluminum alloy, aluminum 3003, aluminum 5052, aluminum 6061, aluminum 7075 ADC-12, Aluminum A356, or any metal suitable for creating a base plate. In many embodiments, the base plate is made of aluminum 6061. The material of the base plate can vary based upon the intended use and/or desired weight of the base plate.

8. Pivot Cup Bushing

The pivot cup receiving port (of the base plate) can be centrally located on the base plate with respect to the perimeter walls (of the base plate). In many embodiments, the pivot cup receiving port can be configured to receive a pivot cup bushing. The pivot cup bushing is generally comprised of a different material than the pivot cup receiving port. For example, in many embodiments, the pivot cup bushing can be comprised of a plastic, polyurethane, or Delrin material. As will be seen in the below embodiments, the pivot cup receiving port can be located rearward of the base plate's king pin receiving aperture.

The pivot tip of the pivot saddle can be configured to be received in the pivot cup bushing, and likewise the pivot cup bushing is configured to be received within the pivot cup receiving port. The combination of the pivot tip, the pivot cup bushing, and the pivot cup receiving port enables less metal-to-metal friction and the ability to more effectively pivot, turn, and/or alter the skateboard truck in different directions.

The hanger further comprises one or more arms that are rotatably coupled to the elongated body of the hanger. In many of the illustrated embodiments, the one or more arm(s) can be on opposing sides of the pivot saddle, or alternatively the pivot saddle in combination with the one or more arm(s) can create a backstop. Thereby, establishing a mechanical lock to prevent overextension or over rotation of the one or more arm(s).

The one or more arm(s) includes a first segment and a second segment. The first segment can be considered as the leading segment and is forward of the second segment ("rear

segment"). The second segment can also be considered as the trailing segment and is rearward of the first segment. In many embodiments, as illustrated by FIGS. 1-4, the first segment can be a similar or equivalent length to the second segment. In other embodiments, the first segment can be between 15% and 35% longer in length than the second segment. In further embodiments, the first segment can be between 15%-17%, 17%-19%, 19%-21%, 21%-23%, 23%-25%, 25%-27%, 27%-29%, 29%-31%, 31%-33%, and 33%-35% longer in length relative to the second segment. In many embodiments, the first segment can be 15%, 16%, 17%, 18%, 19%, 20%, 21%, 22%, 23%, 24%, 25%, 26%, 27%, 28%, 29%, 30%, 31%, 32%, 33%, 34%, or 35% longer in length than the second segment.

The first segment and second segment of the one or more arms can form together to be substantially coplanar with one another. In other embodiments, the first segment and the second segment can be angled relative to one another between 160 degrees and 180 degrees. For example, in some embodiments, the angle between the first segment and the second segment can be approximately between 160 degrees-165 degrees, 165 degrees-170 degrees, 170 degrees-175 degrees, or 175 degrees-180 degrees. In alternative embodiments, the angle between the first segment and the second segment can be 160 degrees, 161 degrees, 162 degrees, 163 degrees, 164 degrees, 165 degrees, 166 degrees, 167 degrees, 168 degrees, 169 degrees, 170 degrees, 171 degrees, 172 degrees, 173 degrees, 174 degrees, 175 degrees, 176 degrees, 177 degrees, 178 degrees, 179 degrees, or 180 degrees.

The one or more arms can further comprise a front region, which can be similar to the first segment, a rear region, which can be similar to the second segment, and a middle region which is in between the first segment and the second segment. The front region forms a first aperture (also known as a "front aperture"). The middle region forms a second aperture (also known as a "middle aperture"). The rear region forms a third aperture (also known as a "rear aperture"). The aperture can be in the form of a through aperture, a bore aperture, a cylindrical aperture, and/or a circular aperture. The diameter of the first aperture ("front aperture"), second aperture ("middle aperture"), and third aperture ("rear aperture") can be equivalent to one another or different from one another.

The diameter of the front aperture, the middle aperture, and the rear aperture can range between 0.25 inch to 1.01 inches. In many embodiments, the front aperture, the middle aperture, and the rear aperture can be range between 0.25 inch-0.27 inch, 0.27 inch-0.29 inch, 0.29 inch-0.31 inch, 0.31 inch-0.33 inch, 0.33 inch-0.35 inch, 0.35 inch-0.37 inch, 0.37 inch-0.39 inch, 0.39 inch-0.41 inch, 0.41 inch-0.43 inch, 0.43 inch-0.45 inch, 0.45 inch-0.47 inch, 0.47 inch-0.49 inch, 0.49 inch-0.51 inch, 0.51 inch-0.53 inch, 0.53 inch-0.55 inch, 0.55 inch-0.57 inch, 0.57 inch-0.59 inch, 0.59 inch-0.61 inch, 0.61 inch-0.63 inch, 0.63 inch-0.65 inch, 0.65 inch-0.67 inch, 0.67 inch-0.69 inch, 0.69 inch-0.71 inch, 0.71 inch-0.73 inch, 0.73 inch-0.75 inch, 0.75 inch-0.77 inch, 0.77 inch-0.79 inch, 0.79 inch-0.81 inch, 0.81 inch-0.83 inch, 0.83 inch-0.85 inch, 0.85 inch-0.87 inch, 0.87 inch-0.89 inch, 0.89 inch-0.91 inch, 0.91 inch-0.93 inch, 0.93 inch-0.95 inch, 0.95 inch-0.97 inch, 0.97 inch-0.99 inch, or 0.99 inch-1.01 inch. In specific embodiments, the front aperture, the middle aperture, and the rear aperture can be approximately 0.25-inch, approximately 0.30-inch, approximately 0.35-inch, approximately 0.40-inch, approximately 0.45-inch, or approximately 0.50-inch.

11

The front aperture of one or more arms can be configured to receive a front axle and a corresponding front wheel. The rear aperture of the one or more arms can be configured to receive a rear axle and a corresponding rear wheel. The middle aperture of the one or more arms can be configured to concentrically attach, link, and/or couple to the elongated body of the hanger. This concentric linkage between the middle aperture of the one or more arms and the elongated body of the hanger creates a lever arm, which can also be referred to as a pivot arm. Thereby, allowing the one or more arms to rotate and/or pivot relative to the elongated body.

As mentioned above, the level arm (or “pivot arm”) rotates about the elongated body. This type of rotation and/or pivot enables the front wheel and/or rear wheels to climb or glide over foreign object debris, such as sidewall contraction joints, pebbles, small rocks, uneven surfaces, or other debris that may be residing on a ground surface. Some of the benefits and advantages of the level arm will further be discussed in the benefits section.

10. Rotation Inhibiting Structure

The truck further can comprise one or more rotation-inhibiting structure(s). The rotation inhibiting structure prevents the level arm (or pivot arm) from excessively rotating past a predetermined angle. The rotation inhibiting structure may be in a variety of forms. For example, in one embodiment the rotation inhibiting structure may integrally protrude or extend from a truck component (i.e. a pivot body). In another embodiment, a truck component can form a rotation inhibiting structure, which can take the form of a notch, gap, slot, or slit. The rotation inhibiting structure beneficially prevents the level arm or pivot arm from excessive rotation to the point where either the front wheel or the rear wheel contacts a bottom surface of the skateboard deck during engagement of the skateboard or longboard.

In one exemplary embodiment, when the front wheel and the rear wheel of the level arm or pivot arm resides on a ground surface, the rotation inhibiting structure prevents the front end and rear end of the pivot arm from upwardly rotating past 50 degrees. In other embodiments, the rotation inhibiting structure may prevent the front end and the rear end of the pivot arm from upwardly rotating past 45 degrees, 40 degrees, 35 degrees, 30 degrees, 25 degrees, 20 degrees, 15 degrees, 10 degrees, or 5 degrees. In alternative embodiments, the predetermined range of motion for the front end and rear end of the level arm (or pivot arm) can be approximately between 0 degrees and 45 degrees, 0 degrees and 40 degrees, 0 degrees and 35 degrees, 0 degrees and 30 degrees, 0 degrees and 25 degrees, 0 degrees and 20 degrees, 0 degrees and 15 degrees, 0 degrees and 10 degrees, or 0 degrees and 5 degrees.

A 0-degree reference angle is defined as the position where both the front wheel and the rear wheel of the level arm or pivot arm reside on a substantially flat ground surface. As the pivot arm begins to upwardly rotate (i.e. the perpendicular distance between the front wheel or rear wheel relative to the bottom surface of the skateboard deck is shorter than the perpendicular distance between the front wheel and rear wheel at a rest position (on a substantially flat ground surface) relative to the bottom surface of the skateboard deck. The effect of the rotation inhibiting structure is present when the pivot arm or level arm reaches a predetermined rotation threshold angle.

11. Friction Reducing Element

In many exemplary embodiments, the truck preferably comprises a friction reducing element. In general, the friction reducing element is a component between the elongated body of the hanger and the one or more of the arms (also can

12

be defined as the medium between the middle aperture of the one or more arm(s) and the elongated body). The friction reducing element reduces the magnitude of frictional forces between the elongated body of the hanger and the one or more arms. Specifically, in many embodiments, the friction reducing element prevents material galling. In alternative embodiments, the friction reducing element can be in the form of a flange. In other embodiments, the friction reducing element can be cylindrical, round, circular, or tubular to compliment the shape of the middle aperture of the one or more arms.

The friction reducing element can be made from any one or combination of the following: nylon, PVC, polythene, polypropylene, or any plastic suitable for reducing friction between two materials. In some embodiments, the friction reducing element is comprised of a nylon material.

I. Benefits

The moving wheel platform described herein beneficially provides enhancements in self-propelled equipment or self-propelled apparatuses. In particular, by creating a moving wheel platform (“skateboard truck” or “truck”) that when fully assembled (“truck assembly”) comprises a rotation inhibiting structure and a pivot/lever arm, the truck assembly effectively maneuvers over foreign objects, such as, but not an exclusive list of sidewalks contraction joints, pebbles, rocks, cracks, or similar objects that creates interference between the wheels and the ground surface (when the self-propelled apparatus is in motion).

In many embodiments, the moving wheel platform (or the skateboard truck) comprises four or more wheels. These wheels can be arranged in a diamond shape configuration. The first and second wheels (two of the four wheels) can be attached to each end of the elongated body. The third and fourth wheels (other two wheels of the four wheels) can be attached to the front segment and rear segment of the one or more pivot/level arm(s). This type of wheel arrangement equally distributes forces loaded onto the truck to create a balanced truck that more effectively glides and/or climbs over sidewalk contraction joints and/or other type of surface cracks. This beneficially prevents (or reduces) the plurality of wheels of the moving wheel platform from entering (or reducing the degree of decent with) sidewalk contraction joints or cracks. Thereby preventing the wheels engaging or getting caught within the sidewalk contraction joint or surface cracks. Thus, eliminating or greatly reducing the possibility of the individual potentially losing balance and/or momentum.

Another beneficial aspect of the moving wheel platform described herein is to have one or more arms concentrically, pivotably, and/or rotatably engaged to the elongated body of the hanger. By having one or more arms rotatable or pivotable about the elongated body of the hanger enables the front segment or the trailing segment at any given moment to upwardly rotate away from the ground surface. For example, the one or more arms that are concentrically and pivotally connected to the elongated body of the hanger may rotate based upon a shift in the skateboard’s center of mass (i.e. the mass of the rider being repositioned on the skateboard deck caused by a slope, turn, etc).

Another beneficial aspect of the moving wheel platform described herein is to have one or more rotation inhibiting structures. Integrating rotation inhibiting structures into the moving wheel platform or truck mechanically prevents over-rotation of the one or more pivot arms past a predetermined degree of rotation. This beneficially prevents the

plurality of wheels positioned on the first segment and/or trailing segment from inadvertent contact with the bottom portion of a skateboard deck.

Another beneficial aspect of the moving wheel platform described herein is to have at least one friction reducing element. The friction reducing element can be positioned between the middle aperture of the one or more arms and the elongated body of the hanger. The friction reducing element beneficially reduces frictional forces between the cylindrical body of the hanger and the one or more arms. Additionally, the friction reducing element can prevent material galling between the one or more arms and the elongated body of the hanger.

II. Embodiments

At least some exemplary embodiments of a moving wheel platform according to this invention are described herein, including skateboard trucks and longboard trucks. Such apparatus may include all or some of the aforementioned components, features, and benefits.

Skateboard Truck I

FIGS. 1-7 illustrates an embodiment of a moving wheel platform (or truck). The truck described herein comprises an elongated body having a pivot saddle protruding (or extending) therefrom. The pivot saddle **105** is configured to have one or more rotation inhibiting structure(s) **127** protruding (or extending) outwardly towards the first end **130** and/or second end **131** of the elongated body **102**. The one or more rotation inhibiting structure(s) **127** can be adjacent and on opposing sides of the pivot saddle and spaced from the elongated body **102**. The spaced formed between the one or more rotation inhibiting structure(s) **127** can be adapted to receive a complimentary middle region geometry (with respect to the rotation inhibiting structure) of the one or more arm(s) **117**.

Specifically, FIG. 1 illustrates a moving wheel platform in the form of a skateboard truck **100**. FIG. 2 illustrates a partial exploded view of the skateboard truck of FIG. 1. FIG. 3 illustrates a zoomed in view of the skateboard truck of FIG. 1. FIG. 4 illustrates a partial assembly of the skateboard truck of FIG. 1. FIGS. 5 and 6 each illustrate an individual truck component of a hanger and an arm, respectively. FIG. 7 illustrates another perspective view of FIG. 3.

FIG. 1 illustrates an example of a skateboard truck to be ridden by a rider (not shown). The rider has a weight (i.e. without limitation, helmet, wrist guards, elbow pads, and knee pads, as appropriate, and anything else the rider is carrying or supporting such as a backpack).

Continuing reference to FIG. 1, the truck **100** is attached to a bottom surface **112** of the skateboard deck **111**. The skateboard deck **111** includes a top surface **113** to support the rider (not shown). In this embodiment, the skateboard includes a front truck **100** and a rear truck **200**. The front truck and the rear truck share similar components and designs. The front truck **100** can be attached to the bottom surface **112** of the skateboard deck **111** at a front portion **114** of the skateboard deck. The rear truck **200** can be attached to the bottom surface **112** of the skateboard deck **111** at a rear portion of the skateboard deck **111**.

FIGS. 1 and 4 further illustrates an assembled arrangement of the above described components to form the front truck **100** and the rear truck **200**. In this exemplary embodiment, the components of the front truck **100** and the rear truck **200** include a hanger **101** having an elongated body

102 and a pivot saddle **105** (which comprises a pivot body **106** and a pivot tip **107**), at least four axles **103**, a base plate **108**, at least two arms **117**, at least two rotation inhibiting structures **127**, and at least two friction reducing elements **126**.

I. Elongated Body

The elongated body **102** can be sized to be approximately the width of the skateboard deck **111** shown in FIG. 1 (which is also illustrated in FIGS. 4 and 5). As previously described above, the width of the elongated body **102** can range between approximately 4 inches to approximately 10 inches. In particular, the width of the elongated body **102** can be approximately 4 inches, approximately 5 inches, approximately 6 inches, approximately 7 inches, approximately 8 inches, approximately 9 inches, or approximately 10 inches. In alternative embodiments, the width of the elongated body **102** can be approximately 4 inches—approximately 5 inches, approximately 5 inches—approximately 6 inches, approximately 6 inches—approximately 7 inches, approximately 7 inches—approximately 8 inches, approximately 8 inches—approximately 9 inches, or approximately 9 inches—approximately 10 inches. In this embodiment, the width of the elongated body **102** can be approximately 7 inches.

The elongated body **102** forms a void **129** that extends from and partially through both the first end **130** and the second end **131** of the elongated body **102**. As described above, the void **129** of the elongated body extends between 5% and 45% of the elongated body width on each end (i.e. the first end **130** and the second end **131**) of the corresponding elongated body end. For example, the void can extend through each end of the elongated body **102** between 5%, 10%, 15%, 20%, 25%, 30%, 35%, 40%, or 45% of the width of the elongated body. In other embodiments, the void can extend through each end (the first end and the second end) of the elongated body **102** between approximately 1%-5%, 5%-10%, 10%-15%, 15%-20%, 20%-25%, 25%-30%, 30%-35%, 35%-40%, or 40%-45%. In alternative embodiments, the void can extend through each end of the elongated body at a distance less than the total width of the elongated body **102**. In this illustrative example, each void formed partially by the first end **130** and the second end **131** extends approximately 20% of the width of the elongated body **102**.

a. Axle(s)

Each void **129** formed by the elongated body **102** can further be threaded and configured to receive to receive an axle **103** that is partially threaded. The void **129** and the axle **103** are arranged together to form a threadable engagement. In this illustrative embodiment, the axle **103** is comprised of a metal material, and more particularly comprised of a steel or steel alloy. The length of the axle **103** will vary based upon the characteristics (i.e. dimensions, etc.) of the void **129**. This specific embodiment illustrates the truck comprising at least four axles. As will be further discussed below, each axle is configured to receive at least one wheel **104**.

FIGS. 1-7 further illustrates that each axle **103** connected to the elongated body **102** of the hanger **101** is configured to retain at least one wheel **104**. In this arrangement, a wheel is positioned proximal to the first end **130** and the second end **131** of the elongated body **102**. Therefore, terminology throughout the specification may consider that the wheel **104** proximal to the first end **130** of the elongated body **102** is a leftward wheel. Similarly, terminology throughout the specification may consider that the wheel **104** proximal to the second end **131** of the elongated body **102** is a rightward wheel.

b. Pivot Saddle

The elongated body **102** of the hanger **101** is integrally connected to the pivot saddle **105** (see FIG. 5). The pivot saddle **105** enables the wheels **104** to turn or alter the direction of the skateboard deck **111**. In this particular embodiment, the pivot saddle **105** is symmetrically positioned relative to the width of the elongated body **102**. As described above, the pivot saddle **105** comprises a pivot body **106** (which forms an aperture **132**) and a pivot tip **107**. The aperture **132** of the pivot body **106** comprises a diameter of approximately 0.5 inch. In alternative embodiments, the diameter of the pivot body aperture **132** can range between approximately 0.2 inches and approximately 3 inches.

The pivot body and pivot tip combine to form a pivot body length **133**. The pivot body length **133** can range between 1 inch and 5 inches. In particular, the pivot body length **133** can be 1 inch, 1.5 inches, 2 inches, 2.5 inches, 3 inches, 3.5 inches, 4 inches, 4.5 inches, or 5 inches. In the illustrative embodiment, the pivot body length **133** can be approximately 2.5 inches. The pivot body length **133** can vary based upon the intended use of the rider. For example, a shorter pivot body length **133** (i.e. less than 2.5 inches) may be desirable if the user wants a more responsive truck with respect to movement in the left and/or right direction, or vice versa a longer pivot body length **133** for a less responsive truck (i.e. greater than 2.5 inches). A shorter pivot body length, however, can introduce wheel bite (wheels contacting the bottom surface of the skateboard), which creates the need for rotation inhibiting structures **127**.

c. Rotation Inhibiting Structure

The pivot saddle **105** of the hanger **101** further comprises an integrally connected rotation inhibiting structure **127**. The rotation-inhibiting structure prevents one or more arms **117** from over rotating to the point where the wheels **104** engage the bottom surface **112** of the skateboard deck **111**. As illustrated by FIGS. 1-7, the rotation-inhibiting structure(s) **127** are adjacent, coplanar, and on opposing sides of the pivot saddle **105** and spaced from the elongated body **102**. In alternative embodiments, only one rotation-inhibiting structure **127** is needed to prevent the arms **117** from over rotating, as the arms **117** are coupled to one another by axles. Therefore, the arms **117** move, rotate, and stop in unison.

The rotation-inhibiting structure spacing distance can be defined as being measured perpendicularly from the elongated body **102** to the rotation inhibiting structure **127**. The rotation inhibiting structure spacing distance can range between 0.125 inch and 3 inches. In particular, the rotation inhibiting structure spacing distance can be between 0.125 inch-0.225 inch, 0.225 inch-0.325 inch, 0.325 inch-0.425 inch, 0.425 inch-0.525 inch, 0.525 inch-0.625 inch, 0.625 inch-0.725 inch, 0.725 inch-0.825 inch, 0.825 inch-0.925 inch, 0.925 inch-1.025 inch, 1.025 inch-1.125 inch, 1.125 inch-1.225 inch, 1.225 inch-1.325 inch, 1.325 inch-1.425 inch, 1.425 inch-1.525 inch, 1.525 inch-1.625 inch, 1.625 inch-1.725 inch, 1.725 inch-1.825 inch, 1.825 inch-1.925 inch, 1.925 inch-2.025 inch, 2.025 inch-2.125 inch, 2.125 inch-2.225 inch, 2.225 inch-2.325 inch, 2.325 inch-2.425 inch, 2.425 inch-2.525 inch, 2.525 inch-2.625 inch, 2.625 inch-2.725 inch, 2.725 inch-2.825 inch, 2.825 inch-2.925 inch, or 2.925 inch-3.025 inch.

The geometry of the rotation inhibiting structure **127** of this exemplary embodiment includes a center portion **134** comprising a semi-circular profile and elongated end protrusions **135** connected to both sides of the semi-circular profile.

As previously mentioned, the center portion **134** of the rotation-inhibiting structure **127** comprises a semi-circular profile. The semi-circular profile of the center portion **134** can have a diameter that ranges between 0.1 inch to approximately 1 inch. For example, in some embodiments, the diameter of the semi-circular profile can be 0.1-inch, 0.2-inch, 0.3-inch, 0.4-inch, 0.5-inch, 0.6-inch, 0.7-inch, 0.8-inch, 0.9-inch, or 1-inch. In other embodiments, the diameter of the semi-circular profile can be between 0.1 inch-0.3-inch, 0.3 inch-0.5-inch, 0.5 inch-0.8-inch, or 0.8 inch-1.1 inch.

As described above, the semi-circular profile of the center portion **134** is connected to elongated end protrusions **135** that protrudes from the semi-circular profile. The elongated end protrusions **135** can generally take any shape, length, or geometry, as long as, the elongated end protrusions are configured to limit rotation of the one or more arm(s) **117** to a predetermined angle. In many embodiments, the elongated end protrusions **135** can be non-circular or non-elliptical. In the illustrative embodiment, the length of rotation inhibiting structure is approximately 2.5 inches (measured along the longitudinal direction of the skateboard). Rotation of the one or more arm(s) **117** is limited when a portion of the arm contacts a portion of the rotation inhibiting structure **127**, thereby forming a mechanical stop (see FIG. 7).

As previously mentioned, the length of the rotation-inhibiting structure is measured in a direction extending along the longitudinal axis of the skateboard deck **111**. In many embodiments, the length of the rotation-inhibiting structure can range between approximately 0.5 inch and approximately 4 inches. For example, the length of the rotation-inhibiting structure can be between 0.5 inch-0.75 inch, 0.75 inch-1.00 inch, 1.0 inch-1.25 inch, 1.25 inch-1.50 inch, 1.50 inch-1.75 inch, 1.75 inch-2.00 inch, 2.00 inch-2.25 inch, 2.25 inch-2.50 inch, 2.50 inch-2.75 inch, 2.75 inch-3.00 inch, 3.00 inch-3.25 inch, 3.25 inch-3.50 inch, 3.50 inch-3.75 inch, or 3.75 inch-4.00 inch.

The width of the rotation inhibiting structure **127** can vary based upon the width of the one or more arms. In general, the width of the rotation inhibiting structure **127** may be approximately the same width of the one or more arms **117** or less than the widths of the one or more arms **117**. Constraining the width to be approximately the same or less than the width of the one or more arms **117** ensures that enough surface area of the rotation inhibiting structure **127** contacts the one or more arms **117** to prevent over rotation.

In this embodiment, the width of the rotation inhibiting structure **127** is approximately 0.375 inch. However, in other embodiments, the width of the rotation inhibiting structure can vary between 0.125 inch to approximately 0.6 inch. For example, the width of the rotation inhibiting structure can be between 0.125 inch-0.145 inch, 0.145 inch-0.165 inch, 0.165 inch-0.185 inch, 0.185 inch-0.205 inch, 0.205 inch-0.225 inch, 0.225 inch-0.245 inch, 0.245 inch-0.265 inch, 0.265 inch-0.285 inch, 0.285 inch-0.305 inch, 0.305 inch-0.325 inch, 0.325 inch-0.345 inch, 0.345 inch-0.365 inch, 0.365 inch-0.385 inch, 0.385 inch-0.405 inch, 0.405 inch-0.425 inch, 0.425 inch-0.445 inch, 0.445 inch-0.465 inch, 0.465 inch-0.485 inch, 0.485 inch-0.505 inch, 0.505 inch-0.525 inch, 0.525 inch-0.555 inch, 0.555 inch-0.575 inch, 0.575 inch-0.595 inch, or 0.595 inch-0.615.

d. Arm(s)

As illustrated by FIG. 6, the middle region **121** of the arm(s) **117** are positioned in the space (or gap) between the rotation inhibiting structure **127** and the elongated body **102**. As mentioned above, the one or more arms can further comprise a front region, which can be similar to the first segment, a rear region, which can be similar to the second segment, and a middle region, which is in between the first

segment and the second segment. In some embodiments, the first segment **118** and the second segment **119** of the arms **117** are equivalent lengths and coplanar to one another. In other embodiments, the length of the arms **117** can range between approximately 4 inches and approximately 9 inches. The length of the arms **117** can be between approximately 4 inches-approximately 5 inches, approximately 5 inches-approximately 6 inches, approximately 6 inches-approximately 7 inches, approximately 7 inches-approximately 8 inches, or approximately 8 inches-approximately 9 inches. In further embodiments, the length of the arms **117** can be approximately 4 inches, approximately 5 inches, approximately 6 inches, approximately 7 inches, approximately 8 inches, or approximately 9 inches.

FIG. **3** illustrates a close-up view of FIG. **1**. FIG. **3** illustrates that the one or more arms **117** can be divided into a front region **120**, a middle region **121**, and a rear region **122**. As previously described, the front region **120** is similar to the first segment **118**, the rear region **122** is similar to the second segment **119**, and the middle region **121** is between the front region **120** and the rear region **122**.

FIG. **3** further illustrates the front region **120** forming a front aperture **123**, the middle region **121** forming a middle aperture **124**, and the rear region **122** forming a rear aperture **125**. In the illustrative embodiment, the front aperture **123** and the rear aperture **125** comprise a smaller diameter relative to the diameter of the middle aperture **124**. Specifically, the diameter of the front aperture **123** and the rear aperture **125** are approximately 0.3 inch and the diameter of the middle aperture **124** is approximately 0.8 inch.

FIGS. **1-4** further illustrate that the front aperture **123** and the rear aperture **125** of each arm **117** can be configured to receive an axle **103**. Each axle **103** is configured to retain a wheel **104**. In this arrangement, at least two wheels **104** are positioned in between (or enclosed by) the arms **117** (or a first arm and a second arm). In other words, at least two wheels are pinned between two arms **117**. Therefore, terminology throughout the specification may consider that the wheel **104** proximal to the front aperture **123** of the arm **117** is a leading and/or forward wheel. Similarly, terminology throughout the specification may consider that the wheel **104** proximal to the rear aperture **125** of the arm **117** is a trailing wheel and/or rear wheel.

e. Friction Reducing Element

Referring back to FIGS. **1-4**, the embodiment of the truck **100**, **200** further includes a friction reducing element **126** configured to be received within the middle aperture **124** of the arms **117** (i.e. first arm and second arm). In the case of this embodiment, the friction reducing element is comprised of a nylon material and approximately the same width of the arms **117** and the diameter of the middle aperture **124**.

f. Base Plate

As previously described, the base plate **108** is the component of the truck that couples the elongated body **102**, the wheels **104**, and the pivot saddle **105** to the skateboard deck **111** (see FIG. **1**). The base plate forms a plurality of bolt receiving ports **109**, at least one king pin receiving aperture **116**, and at least one pivot cup receiving port **115**. These receiving ports provide receiving geometries for a plurality of bolts, a king pin, and the pivot tip of the pivot saddle, respectively. Thereby, securing the moving wheel platform or the truck to a given apparatus.

The arrangement of the aforementioned truck components described herein enables individuals riding skateboards or longboards to more efficiently maneuver over cracks in sidewalks as the configuration of the truck components enables the wheels coupled to the elongated body of the

hanger to be suspended over a contraction joint (i.e. prevents the wheels from descending into the crack when the user is moving over a contraction joint). Further, the rotation-inhibiting structures prevents the wheels coupled to the rotatable arms **117** from contacting a bottom portion of the skateboard (i.e. preventing wheel bite).

Skateboard Truck II

FIGS. **8-11** illustrates another embodiment of a moving wheel platform (or truck). The truck described herein comprises an elongated body **302** having a pivot saddle **305** protruding (or extending) therefrom. The elongated body **302** and the pivot saddle **305** cooperate to form one or more rotation inhibiting structure(s) **327** in the form of a void. In many embodiments, one or more arms **317** can be positioned in the space formed by the void defined by the rotation inhibiting structure **327**.

The one or more arm(s) **317** further comprises a first rotation inhibiting protrusion **341** and a second rotation inhibiting protrusion **342** that extends outwardly away from the arms **317**. When the arms **317** are assembled to the hanger, the first rotation inhibiting protrusion **341** and the second rotation inhibiting protrusion **342** forms an overlapping structure that surrounds (or encompasses) a portion of the pivot body **306**. As the arms **317** begin to rotate/pivot away from the ground surface, the first rotation inhibiting protrusion **341** and the second rotation inhibiting protrusion **342** can contact the pivot body **306** providing a mechanical stop to prevent over rotation of the arms **317**.

FIG. **8** illustrates an exploded view of a moving wheel platform according to some aspects of this invention. FIG. **9** further illustrates that the moving wheel platform (or truck) **300** can be mounted to a longboard or another apparatus, in accordance with some aspects of this invention. FIGS. **10** and **11** each individually illustrate a hanger and an arm, respectively.

In the embodiments of FIGS. **8-11**, the truck **300** comprises a plurality of components including a hanger **301** having an elongated body **302**, one axle **303**, a pivot saddle **305** having a pivot body **306** and a pivot tip **307**, a base plate **308**, at least two arms **317**, at least two rotation inhibiting structures **327**, and at least two friction reducing elements **326**.

I. Elongated Body

The elongated body **302** of this embodiment is configured to be approximately the width of a skateboard deck **311** (of FIG. **9**). As previously described, the width of the elongated body **302** can range between approximately 4 inches to approximately 10 inches. In particular, the width of the elongated body **302** can be 4 inches, 5 inches, 6 inches, 7 inches, 8 inches, 9 inches, or 10 inches. In this exemplary embodiment, the width of the elongated body **302** is approximately 7 inches.

The elongated body **302** forms a bore **329** that extends entirely through both the first end **330** and the second end **331** of the elongated body **302**. In other words, the bore **329** extends entirely (100%) through the width of the elongated body **302**. In this embodiment, the elongated body is formed from Aluminum 6061 or the cast equivalent Aluminum A356.

II. Axle

The bore **329** defined by the elongated body **302** is configured to rigidly receive one axle **303**. Specifically, when compared to the previous embodiment (FIGS. **1-7**), this embodiment requires only one axle. This not only requires less components compared to the previous embodi-

ment, but further enables the elongated body to better support the axle, as more surface area of the elongated body is engaged with the axle. In this embodiment, the axle **303** is comprised of a metal material, and more particularly comprised of a steel or steel alloy. The length of the axle **303** will vary based on the width of the elongated body **302**. As will be further discussed below, each axle is configured to receive one or more wheels **304**.

The axle **303** comprises four segments. The first segment of the axle is proximal to the first end of the elongated body. The second segment of the axle is proximal to the second end of the elongated body. The third segment of the axle is in between the first segment and the second segment. The fourth segment of the axle is in between the first segment and the second segment and comprises a hanger stop **346** that abuts a portion of the elongated body, and particularly, the first end of the elongated body.

The hanger stop **346** wraps circumferentially around the axle **303** and is the thickest portion of the axle. The first segment of the axle extends from the first end of the elongated body to create a first overhang portion. Similarly, the second segment of the axle extends from the second end of the elongated body to create a second overhang portion. The first and second overhang portions accommodate, the first and second wheels for securing the first and second wheels to the axle **303**, respectively.

III. Rotation Inhibiting Structures

The elongated body **302** further forms at least two rotation inhibiting structures **327** in the form of a gap, a notch, a slot, or a slit. The rotation inhibiting structures **327** are offset and/or spaced from the first end **330** and second end **331** of the elongated body **302**. For example, in the illustrated embodiment of FIGS. **8-10**, the rotation inhibiting structures **327** are symmetrically positioned along the width of the elongated body **302**. Specifically, in the illustrated embodiment, the rotation inhibiting structures **327** are offset approximately 34% from the first end **330** and the second end **331** of the elongated body, respectively.

However, in alternative embodiments, the rotation inhibiting structures **327** can be offset from the first end **330** or the second end **331** of the elongated body between 5% and 50%. For example, in many embodiments, the offset distance between the first end and the rotation inhibiting structure **327** or the second end and the rotation inhibiting structure **327** can be 5%, 6%, 7%, 8%, 9%, 10%, 11%, 12%, 13%, 14%, 15%, 16%, 17%, 18%, 19%, 20%, 21%, 22%, 23%, 24%, 25%, 26%, 27%, 28%, 29%, 30%, 31%, 32%, 33%, 34%, 35%, 36%, 37%, 38%, 39%, 40%, 41%, 42%, 43%, 44%, 45%, 46%, 47%, 48%, 49%, or 50%.

The rotation-inhibiting structure **327** comprises at least three internal sidewalls defined by the elongated body **302** (i.e. a first internal sidewall **337**, a second internal sidewall **338**, and a third internal sidewall **339**). The first internal wall is defined as the sidewall closest to either one of the first end **330** or the second end **331** of the elongated body **302**. The second internal wall **338** is defined as the sidewall proximal to a sidewall of the other rotation inhibiting structure **327**. The third internal wall sidewall **339** shares a common edge with both the first internal wall **337** and the second internal wall **339**. The first internal sidewall **337**, the second internal sidewall **338**, and the third internal sidewall **339** forms a void therebetween. In many embodiments, where the one or more sidewalls meet to form an edge, a radius can be present.

The distance between a pair of rotation-inhibiting structures **327** can be referred to as a rotation inhibiting structure spacing distance **340**. The rotation inhibiting structure spac-

ing distance **340** can be defined as the distance measured between the pair of rotation-inhibiting structures second internal sidewalls **338**. In the illustrated embodiment, the rotation inhibiting structure spacing distance **340** is approximately 1.25 inches. However, in alternative embodiments, the rotation inhibiting structure spacing distance **340** may range between 0.25 inches and 2 inches.

In other embodiments, the rotation inhibiting structure spacing distance **340** can range between approximately 0.25 inch-0.50 inch, 0.50 inch-0.75 inch, approximately 0.75 inch-1.00 inch, approximately 1.00 inch-1.25 inch, approximately 1.25 inch-1.50 inch, approximately 1.50 inch-1.75 inch, or approximately 1.75 inch-2.00 inch. The rotation inhibiting structure can be approximately 0.25-inch, 0.50-inch, approximately 0.75 inch, approximately 1.00 inch, approximately 1.25 inch, approximately 1.50 inch, approximately 1.75 inch, or approximately 2.00 inch.

IV. Arm(s)

With continued reference to FIG. **10**, the one or more arms **317** can be divided into a front region **320**, a middle region **321**, and a rear region **322**. As previously described (and similar to the previously mentioned arms **117**), the front region **320** is similar to the first segment **318**, the rear region **322** is similar to the second segment **319**, and the middle region **321** is between the front region **320** and the rear region **322**. FIGS. **8** and **10** further illustrates the front region **320** forms a front aperture **323**, the middle region **321** forms a middle aperture **324**, and the rear region **322** forms a rear aperture **325**. In the illustrative embodiment, the front aperture **323** and the rear aperture **325** comprises a smaller diameter than the diameter of the middle aperture **324**.

The middle region of the one or more arms **317** comprises a first rotation inhibiting protrusion **341** protruding from the middle region and front region **320** of the arm **317**, a second rotation inhibiting protrusion **342** protruding from the middle region and rear region **322** of the arm **317**, and a middle aperture **324**. The first rotation inhibiting protrusion **341** is closer to the front region **320** of the arm **317** than the rear region **322** of the arm **317**. The second rotation inhibiting protrusion **342** is closer to the rear region **322** than the front region **320**.

An imaginary centerline axis is symmetrically positioned between the first rotation inhibiting protrusion **341** and the second rotation inhibiting protrusion **342** and extends through a center point of the middle aperture **324**. Thereby, forming a first rotation inhibiting protrusion angle between the centerline axis and the first rotation inhibiting protrusion and a second rotation inhibiting protrusion angle between the centerline axis and the second rotation inhibiting protrusion.

The first rotation inhibiting angle **343** can range between 2 degrees and 6 degrees. In some embodiments, the first rotation inhibiting angle **343** can range approximately between 2 degrees-2.5 degrees, 2.5 degrees-3 degrees, 3 degrees-3.5 degrees, 3.5 degrees-4 degrees, 4 degrees-4.5 degrees, 4.5 degrees-5 degrees, 5 degrees-5.5 degrees, or 5.5 degrees-6 degrees. In alternative embodiments, the first rotation inhibiting angle **343** can be approximately 2 degrees, approximately 2.5 degrees, approximately 3 degrees, approximately 3.5 degrees, approximately 4 degrees, approximately 4.5 degrees, approximately 5 degrees, approximately 5.5 degrees, or approximately 6 degrees. In the illustrated embodiment, the first rotation inhibiting angle is approximately 4 degrees.

The second rotation inhibiting angle **344** can range approximately between 12 degrees and 18 degrees. In some embodiments, the second rotation inhibiting angle **344** can

range between 12 degrees-13 degrees, 13 degrees-14 degrees, 14 degrees-15 degrees, 16 degrees-17 degrees, or 17 degrees-18 degrees. In alternative embodiments, the first rotation inhibiting angle **344** can be 12 degrees, 12.5 degrees, 13 degrees, 13.5 degrees, 14 degrees, 14.5 degrees, 15 degrees, 15.5 degrees, 16 degrees, 16.5 degrees, 17 degrees, 17.5 degrees, or 18 degrees. In the illustrated embodiment, the second rotation inhibiting angle **344** is approximately 16 degrees.

The middle region of the arms **317** can be sized, arranged, and/or configured to be received within the void **345** of the rotation inhibiting structures **327**. The axle **302** not only extends entirely through elongated body, but also extends through the void **345** and middle aperture **324**, thereby rigidly supporting both the elongated body of the hanger and the arm(s) while providing an axis of rotation for the arms **317** to rotate about. The combination of the rotation inhibiting structure **327** and the first and second rotation inhibiting protrusion **341**, **342** of the arms **117** forms an overlapping structure that surrounds (or encompasses) a portion of the pivot body.

When the truck **300** is in a zero-degree reference angle configuration, the overlapping structure will not be felt or apparent to the rider, however, as the arms **317** begin to rotate/pivot away from the ground surface, the first rotation inhibiting protrusion and the second rotation inhibiting protrusion can contact the pivot body **306** providing a mechanical stop. This mechanical stop prevents over rotation of the one or more arms to the point where the wheels **304** contact the bottom surface of the skateboard deck.

FIG. **8** further illustrate that the front aperture **323** and the rear aperture **325** of each of the arms **317** is configured to an axle. Each axle **303** is configured to retain at least one wheel **304**. In this arrangement, two or more wheels can be positioned in between arms **317**. Therefore, terminology throughout the specification may consider that the wheel **304** (pinned) proximal to the front aperture **323** of the arms **317** is a leading and/or forward wheel. Similarly, terminology throughout the specification may consider that the wheels **304** (pinned) proximal to the rear aperture **325** of the arm **317** is a trailing wheel and/or rear wheel.

With continued reference to FIGS. **8** and **10**, the embodiment of the truck **300** further includes a friction reducing element **326** configured to be received within the middle aperture **324** of the arms **317**. In the case of this embodiment, the friction reducing element is composed of a nylon material and approximately the same width of the arms **317** and the diameter of the middle aperture **324**. In many embodiments, the friction reducing element **326** can be press fit into the middle aperture **324**.

V. Pivot Saddle

Still Referencing FIGS. **8-10**, the pivot body **306** and the pivot tip **307** forms a pivot saddle **305** that is substantially triangular. This type of triangular arrangement extends from the first end **330** of the elongated body **302** and the second end **331** of the elongated body **302**. This type of arrangement acts as a structural support mechanism to the elongated body **302**, as the pivot saddle **305** is substantially engaged to the entire width of the elongated body **302**.

As previously mentioned, the base plate **308** is the component of the truck that couples the elongated body **302**, the wheels **304**, and the pivot saddle **305** to the skateboard deck **111**. The base plate **308** forms a plurality of bolt receiving ports **309**, at least one king pin receiving aperture **316**, and at least one pivot cup receiving port **315**. These receiving ports provide receiving geometries for a plurality of bolts, a

king pin, and the pivot tip of the pivot saddle, respectively. Thereby, securing the moving wheel platform or the truck to a given apparatus.

The arrangement of the aforementioned truck components enables individuals riding skateboards or longboards to more efficiently maneuver over cracks in sidewalks, as the configuration of the truck components enables the wheels coupled to the elongated body of the hanger to be suspended over a contraction joint (i.e. prevents the wheels from descending into the crack when the user is moving over a contraction joint). Further, the rotation-inhibiting structures and rotation inhibiting protrusions of the arms cooperate to prevents one or more wheels from contacting a bottom portion of the skateboard (i.e. preventing wheel bite).

Skateboard Truck III

FIGS. **12** and **13** illustrates another embodiment of a moving wheel platform according to this invention. The truck described herein comprises an elongated body **402** having a pivot saddle **405** protruding (or extending) therefrom. The elongated body **402** and the pivot saddle **405** cooperate to form one or more rotation inhibiting structure(s) **427** in the form of a void. In many embodiments, only one arm **417** is needed to occupy the space formed by the void defined by one or more rotation inhibiting structure(s) **427**. More particularly, FIG. **12** illustrates an exploded view of a truck **400** according to another embodiment. FIG. **13** illustrates an assembled view of the truck **400** of FIG. **12**.

Similarly, to the above truck embodiments, FIGS. **12** and **13** illustrates a preferred arrangement of the above described components to form the truck **400**. In this embodiment, the components of the truck **400** includes a hanger **401** including an elongated body **402**, at least one axle **403**, a pivot saddle **405** having a pivot body **406** and a pivot tip **407**, a base plate **408**, only one arm **417**, at least two rotation inhibiting structures **427**, and at least two sets of friction reducing elements **426**.

The elongated body **402** of this embodiment is similar to the elongated body **302** of the previous embodiments and configured to be approximately the width of a skateboard deck **411** (not shown). As previously described above, the width of the elongated body **402** can range between 4 inches and 10 inches. In particular, the width of the elongated body **402** can be 4 inches, 5 inches, 6 inches, 7 inches, 8 inches, 9 inches, or 10 inches. In this example, the width of the elongated body **402** is approximately 7 inches.

The elongated body **402** forms a bore **429** that extends entirely through both the first end **430** and the second end **431** of the elongated body **402**. The bore **429** extends entirely (100%) through the width of the elongated body **402**. In this embodiment, the elongated body can be formed from Aluminum 6061 or the cast equivalent Aluminum A356.

The bore **429** is configured to rigidly receive one axle **403**. Specifically, when compared to the previous embodiment (FIGS. **1-7**) this embodiment requires only one axle. This not only requires less components compared to the previous embodiment but enables the axle **403** to better support the elongated body **402**, as more surface area of the axle **403** is engaged with the elongated body **402**.

The axle **403** can be comprised of a metal material, and more particularly comprised of a steel or steel alloy. The axle **403** further adds structural support to the elongated body **403**, as the young's modulus is greater than the young's modulus of the elongated body **403** of the hanger. The length of the axle **403** will vary based upon the width of the

elongated body **402**. As will be further discussed below, each axle is configured to receive at least one wheel **404**.

The elongated body **402** and pivot body **406** further defines and/or comprises at least two rotation inhibiting structures **427** in the form of a gap, a notch, a slot, or a slit. The rotation inhibiting structures **427** are offset and/or spaced away from the first end **430** and second end **431** of the elongated body **402**. For example, in the embodiment of FIG. **12**, the rotation inhibiting structures **427** are symmetrically positioned along the width of the elongated body **402**. Specifically, in this embodiment, the rotation inhibiting structures **427** are offset approximately 34% from the first end **430** and the second end **431** of the elongated body, respectively. However, in other embodiments, the rotation inhibiting structures **427** may be offset from the first end **430** or the second end **431** of the elongated body **402** between 25% and 50%. For example, in many embodiments, the offset distance between the first end and the rotation inhibiting structure **427** or the second end and the rotation inhibiting structure **427** may be 25%, 26%, 27%, 28%, 29%, 30%, 31%, 32%, 33%, 34%, 35%, 36%, 37%, 38%, 39%, 40%, 41%, 42%, 43%, 44%, 45%, 46%, 47%, 48%, 49%, or 50%.

The rotation-inhibiting structure **427** comprises at least three internal sidewalls (i.e. a first internal sidewall **437**, a second internal sidewall **438**, and a third internal sidewall **439**). The first internal wall is defined as the sidewall closest to the either one of the first end **430** or the second end **431** of the elongated body **302**. The second internal wall **438** is defined as the sidewall proximal to a sidewall of another rotation inhibiting structure **427**. The third internal wall sidewall **439** shares a common edge with both the first internal wall **437** and the second internal wall **439**. The first internal sidewall **437**, the second internal sidewall **438**, and the third internal sidewall **439** forms a void therebetween.

The distance between a pair of rotation-inhibiting structures **427** can be referred to as a rotation inhibiting structure spacing distance **440**. The rotation inhibiting structure spacing distance **440** can be defined as the distance measured between the pair of rotation-inhibiting structures second internal sidewalls **438**. In this particular embodiment, the rotation inhibiting structure spacing distance **440** can be approximately 1.25 inches.

However, in alternative embodiments, the rotation inhibiting structure spacing distance **440** may range between 0.50 inches and 2 inches. In other embodiments, the rotation inhibiting structure spacing distance **440** may range between 0.50 inch-0.75-inch, 0.75 inch-1.00 inch, 1.00 inch-1.25 inch, 1.25 inch-1.50 inch, 1.50 inch-1.75 inch, or 1.75 inch-2.00 inch. The rotation inhibiting structure may be 0.50-inch, 0.75 inch, 1.00 inch, 1.25 inch, 1.50 inch, 1.75 inch, or 2.00 inch.

FIG. **12** illustrates that the arm **417** can be divided into a front region **420**, a middle region **421**, and a rear region **422**. As previously described above, the front region **420** is similar to the first segment **418**, the rear region **422** is similar to the second segment **419**, and the middle region **421** is between the front region **420** and the rear region **422**. FIG. **11** further illustrates the front region **420** forming a front aperture **423**, the middle region **421** forming a middle aperture **424**, and the rear region **422** forming a rear aperture **425**. In many embodiments, the front aperture **423** and the rear aperture **425** can form a smaller diameter than the diameter of the middle aperture **424**.

The front region **420** further comprises a first region transition area **446**. The rear region **422** comprises a second region transition area **447**. The first region transition area

446 is defined as the area or portion where the front region **420** transitions to the middle region **421**. The second region transition area **447** is defined as the area or portion where the rear region **422** transitions to the middle region **421**. At the first region transition area **446**, the arm **417** splits from one segment into two segments. At the second transition area **447**, the arm **417** splits from one segment into two segments.

In this embodiment, the front region **420** can be a one segment region, the rear region **422** is also a one segment region, however, the middle region, which is in between the front region **420** and the rear region **422** is a two-segment region, which arranges to outline a substantially rectangular shape. Thereby, permitting only one arm **417** to occupy at least two rotation inhibiting structures **427** as the first and second rotation inhibiting protrusions are positioned on both sides of the middle region **421** two segment region.

In other embodiments, at the first region transition area **446**, the arm **417** may split from one segment into two segments, three segments, or four segments. At the second transition area **447**, the arm **417** may split from one segment into two segments, three segments, or four segments.

The middle region of the one or more arms **417** comprises a first rotation inhibiting protrusion **441**, a second rotation inhibiting protrusion **442**, and a middle aperture **424**. The first rotation inhibiting protrusion **441** protrudes (or extends) from the middle region and is closer to the front region **420** than the rear region **322**. The second rotation inhibiting protrusion **442** protrudes from the middle region and is closer to the rear region **422** than the front region **420**. Further, the first and second rotation inhibiting protrusions **341**, **342** are positioned on both sides of the middle region **421** two segment region.

Similarly, to the above described embodiment, a centerline axis exists between the first rotation inhibiting protrusion **441** and the second rotation inhibiting protrusion **442** and extends through a center point of the middle aperture **424**. A first rotation inhibiting protrusion angle is formed between the centerline and the first rotation inhibiting protrusion. A second rotation inhibiting protrusion angle is formed between the centerline and the second rotation inhibiting protrusion.

Similarly, to the above described embodiment, the first rotation inhibiting angle **443** can range between 2 degrees and 6 degrees. In some embodiments, the first rotation inhibiting angle **443** can range between 2 degrees-2.5 degrees, 2.5 degrees and 3 degrees, 3 degrees-3.5 degrees, 3.5 degrees-4 degrees, 4 degrees-4.5 degrees, 4.5 degrees-5 degrees, 5 degrees-5.5 degrees, or 5.5 degrees-6 degrees. In alternative embodiments, the first rotation inhibiting angle **443** can be 2 degrees, 2.5 degrees, 3 degrees, 3.5 degrees, 4 degrees, 4.5 degrees, 5 degrees, 5.5 degrees, or 6 degrees. In the illustrated embodiment, the first rotation inhibiting angle is 4 degrees.

Similarly, to the above described embodiment, the second rotation inhibiting angle **444** can range between 12 degrees and 18 degrees. In some embodiments, the second rotation inhibiting angle **444** can range between 12 degrees and 13 degrees, 13 degrees-14 degrees, 14 degrees-15 degrees, 16 degrees-17 degrees, or 17 degrees-18 degrees. In alternative embodiments, the first rotation inhibiting angle **444** can be 12 degrees, 12.5 degrees, 13 degrees, 13.5 degrees, 14 degrees, 14.5 degrees, 15 degrees, 15.5 degrees, 16 degrees, 16.5 degrees, 17 degrees, 17.5 degrees, or 18 degrees. In the illustrated embodiment, the second rotation inhibiting angle **444** is 16 degrees.

The middle region of the arms **417** are configured to be received within the void **445** of the rotation inhibiting

structures 427. The axle 402 not only extends entirely through elongated body, but also extends through the void 445 and middle aperture 424 of the arm 417, thereby rigidly supporting both the elongated body of the hanger but also provides an axis of rotation for the arm 417 to rotate about. The combination of the rotation inhibiting structure 427 and the first rotation inhibiting protrusion 441 of the arm 417 forms an overlapping structure that surrounds or encompasses a portion of the pivot body.

When the truck 400 is in a zero-degree reference angle configuration, the overlapping structure will not be felt or apparent to the rider, however, as the arms 417 begin to rotate/pivot away from the ground surface, the first rotation inhibiting protrusion and the second rotation inhibiting protrusion can contact the pivot body 406 providing a physical barrier. This physical barrier prevents over rotation of the one or more arms to the point where the wheels 404 contact the bottom surface of the skateboard deck (not shown).

FIGS. 12 and 13 further illustrates that the front aperture 423 and the rear aperture 425 of each of the arm 417 is configured to receive an axle. Each axle 403 is configured to retain at least one wheel 404. In this illustrated embodiment, four wheels are coupled to the arm 417 and positioned on each side (or opposing sides) of the arm 417 at the front aperture 423 and the rear aperture 425. Therefore, terminology throughout the specification may consider that the two wheels 404 proximal to the front aperture 423 of the arm 417 are the leading and/or forward wheels. Similarly, terminology throughout the specification may consider that the two wheels 404 proximal to the rear aperture 425 of the arm 417 are the trailing wheels and/or rear wheels.

With continued reference to FIGS. 12 & 13, the truck 400 further includes a friction reducing element 426 configured to be received within each middle aperture 424 of the arm 417. In the case of this embodiment, the friction reducing element is composed of a nylon material and approximately the same width of the arms 417 and the diameter of the middle aperture 424.

The pivot body 406 and the pivot tip 407 forms a pivot saddle 405 that is substantially triangular. This type of substantially triangular arrangement extends from the first end 430 of the elongated body 402 and the second end 431 of the elongated body 402, therefore additionally acting as a structural support mechanism to the elongated body 402. The axle 403 further adds structural support to the elongated body 403, as the young's modulus is greater than the young's modulus of the elongated body 403 of the hanger.

As previously described, the base plate 408 is the component of the truck that couples the elongated body 402, the wheels 404, and the pivot saddle 405 to the skateboard deck 411. The base plate 408 forms a plurality of bolt receiving ports 409, at least one king pin receiving aperture 416, and at least one pivot cup receiving port (not shown). These receiving ports provides receiving geometries for a plurality of bolts, a king pin, and the pivot tip of the pivot saddle, respectively. Thereby, securing the moving wheel platform or the truck to a given apparatus.

The arrangement of the aforementioned truck components enables individuals riding skateboards or longboards to more efficiently maneuver over cracks in sidewalks as the configuration of the truck components enables the wheels coupled to the elongated body of the hanger to be suspended over a contraction joint (i.e. prevents the wheels from descending into the crack when the user is moving over a contraction joint). Further, this embodiment requires only one arm while still utilizing rotation-inhibiting structures

and rotation inhibiting protrusions of the arms to prevents one or more wheels from contacting a bottom portion of the skateboard (i.e. preventing wheel bite).

Skateboard Truck IV

FIGS. 14-20 illustrates another embodiment of a moving wheel platform according to this invention. The truck described herein comprises an elongated body 502 having a pivot saddle 505 protruding (or extending) therefrom. The elongated body 502 and the pivot saddle 505 cooperate to form one or more rotation inhibiting structure(s) 527 in the form of a void. In many embodiments, only one arm 517 is needed to occupy the space formed by the void defined by one or more rotation inhibiting structure(s) 527. More particularly, FIGS. 14-20 illustrates a truck 500 that can be mounted to a longboard (or another apparatus). The illustrated truck embodiment of FIGS. 14-20 is similar to the previously mentioned trucks.

FIGS. 14-20 illustrates an embodiment of the above described components to form the truck 500. In this embodiment, the components of the truck 500 includes a hanger 501 including an elongated body 502, at least one axle 503, a pivot saddle 505 having a pivot body 506 and a pivot tip 507, a base plate 508, only one arm 517, at least two rotation inhibiting structures 527, and at least two sets of friction reducing elements 526.

The elongated body 502 of this illustrated embodiment is similar to the elongated body 102, 202, 302, and 402 of the previous embodiments and configured to be approximately the width of a skateboard deck 511. As previously described above, the width of the elongated body 502 can range between 4 inches and 10 inches. In particular, the width of the elongated body 502 can be 4 inches, 5 inches, 6 inches, 7 inches, 8 inches, 9 inches, or 10 inches. In this illustrative example, the width of the elongated body 502 is approximately 7 inches.

The elongated body 502 forms a bore 529 that extends entirely through both the first end 530 and the second end 531 of the elongated body 502. The bore 529 extends 100% entirely through the width of the elongated body 502. In this particular embodiment, the elongated body is composed of Aluminum 6061 or the cast equivalent Aluminum A356.

The bore 529 can be configured to rigidly receive one axle 503. Specifically, when compared to Embodiment I, this embodiment requires only one axle. This not only requires less components compared to the previous embodiment, but enables the axle 503 to provide more support to the elongated body 502, as more surface area of the axle 503 is engaged with the elongated body 502.

In this illustrative embodiment, the axle 503 is comprised of a metal material, and more particularly comprised of a steel or steel alloy. The axle 503 further adds structural support to the elongated body 503, as the young's modulus is greater than the young's modulus of the elongated body 503 of the hanger. The length of the axle 503 will vary based on the width of the elongated body 502. This specific embodiment illustrates an axle width of approximately 8 inches. As will be further discussed below, each axle is configured to receive at least one wheel 504.

The elongated body 502 further includes at least two rotation inhibiting structures 527 in the form of a gap, a notch, a slot, or a slit. The rotation inhibiting structures 527 are offset and/or spaced away from the first end 530 and second end 531 of the elongated body 502. For example, in the illustrated embodiment of FIGS. 14-20, the rotation inhibiting structures 527 are symmetrically positioned along

the width of the elongated body **502**. Specifically, in the illustrated embodiment the rotation inhibiting structures **527** are offset approximately 34% from the first end **530** and the second end **531** of the elongated body, respectively. However, in other embodiments, the rotation inhibiting structures **527** may be offset from the first end **530** or the second end **531** of the elongated body **502** between 25% and 50%. For example, in many embodiments, the offset distance between the first end and the rotation inhibiting structure **527** or the second end and the rotation inhibiting structure **527** can be 25%, 26%, 27%, 28%, 29%, 30%, 31%, 32%, 33%, 34%, 35%, 36%, 37%, 38%, 39%, 40%, 41%, 42%, 43%, 44%, 45%, 46%, 47%, 48%, 49%, or 50%.

Similarly, to FIG. **11** the truck **500** shares a similar hanger design of the hanger **301** of skateboard embodiment III and denoted as such. The rotation-inhibiting structure (**327, 427**) **527** comprises at least three internal sidewalls (i.e. a first internal sidewall (**337, 437**) **537**, a second internal sidewall (**338, 438**) **538**, and a third internal sidewall (**339, 439**) **539**). The first internal wall is defined as the sidewall closest to the either one of the first end (**330, 430**) **530** or the second end (**331, 431**) **531** of the elongated body (**302, 402**) **502**. The second internal wall (**338, 438**) **538** is defined as the sidewall proximal to a sidewall of the other rotation inhibiting structure (**327, 427**) **527**. The third internal wall sidewall (**339, 439**) **539** shares a common edge with both the first internal wall (**337, 437**) **537** and the second internal wall (**339, 439**) **539**. The first internal sidewall (**337, 437**) **537**, the second internal sidewall (**338, 438**) **538**, and the third internal sidewall (**339, 439**) **539** forms a void therebetween.

The distance between a pair of rotation-inhibiting structures (**327, 427**) **527** can be referred to as a rotation inhibiting structure spacing distance (**340, 440**) **540**. The rotation inhibiting structure spacing distance (**340, 440**) **540** is defined as the distance measured between the pair of rotation-inhibiting structures second internal sidewalls (**338, 438**) **538**. In the illustrated embodiment, the rotation inhibiting structure spacing distance (**340, 440**) **540** is approximately 1.25 inches. However, in alternative embodiments, the rotation inhibiting structure spacing distance (**340, 440**) **540** may range between 0.50 inches and 2 inches. In other embodiments, the rotation inhibiting structure spacing distance (**340, 440**) **540** may range between 0.50 inch-0.75-inch, 0.75 inch-1.00-inch, 1.00 inch-1.25 inch, 1.25 inch-1.50 inch, 1.50 inch-1.75 inch, or 1.75 inch-2.00 inch. The rotation inhibiting structure may be 0.50-inch, 0.75-inch, 1.00 inch, 1.25 inch, 1.50 inch, 1.75 inch, or 2.00 inch.

FIG. **17** illustrates that arm **517** can be defined by a front region **520**, a middle region **521**, and a rear region **522**. As previously described above, the front region **520** is similar to the first segment **518**, the rear region **522** is similar to the second segment **519**, and the middle region **521** is between the front region **520** and the rear region **522**. FIG. **12** further illustrates the front region **520** forming a front aperture **523**, the middle region **521** forming a middle aperture **524**, and the rear region **522** forming a rear aperture **525**. In the illustrative embodiment, the front aperture **523** and the rear aperture **525** comprises a smaller diameter than the diameter of the middle aperture **524**.

The front region **520** further comprises a first region transition area **546**. The rear region **522** comprises a second region transition area **547**. The first region transition area **546** is defined as the area or portion where the front region **520** transitions to the middle region **521**. The second region transition area **547** is defined as the area or portion where the rear region **522** transitions to the middle region **521**. At the first region transition area **546**, the arm **517** maintains two

segments (to house a wheel between the two segments). At the second transition area **547**, the arm **517** transitions from one segment into two segments (see FIG. **17**). As mentioned, the rear region of the arm is one segment and configured to have one or more wheels on opposing sides of the segment. In the illustrated embodiment, the front region **520** is a two-segment region, the rear region **522** is a one segment region, the middle region, which is in between the front region **520** and the rear region **522** is a two-segment region. In other embodiments, at the first region transition area **546**, the arm **517** may split into three segments, four segments, or five segments. At the section transition area **547**, the arm **517** may split from one segment into two segments, three segments, or four segments.

Similarly to the above described arms (**317, 417**), the middle region of the one or more arms **517** comprises a first rotation inhibiting protrusion **541**, a second rotation inhibiting protrusion **542**, and a middle aperture **524**. The first rotation inhibiting protrusion **541** is closer to the front region **520** than the rear region **522**. The second rotation inhibiting protrusion **542** is closer to the rear region **522** than the front region **520**. A centerline exists between the first rotation inhibiting protrusion **541** and the second rotation inhibiting protrusion **542** and extends through a center point of the middle aperture **524**.

A centerline exists between the first rotation inhibiting protrusion **541** and the second rotation inhibiting protrusion **542** and extends through a center point of the middle aperture **524**. A first rotation inhibiting protrusion angle is formed between the centerline and the first rotation inhibiting protrusion. A second rotation inhibiting protrusion angle is formed between the centerline and the second rotation inhibiting protrusion.

The first rotation inhibiting angle **543** can range between 2 degrees and 6 degrees. In some embodiments, the first rotation inhibiting angle **543** can range between 2 degrees-2.5 degrees, 2.5 degrees and 3 degrees, 3 degrees-3.5 degrees, 3.5 degrees-4 degrees, 4 degrees-4.5 degrees, 4.5 degrees-5 degrees, 5 degrees-5.5 degrees, or 5.5 degrees-6 degrees. In alternative embodiments, the first rotation inhibiting angle **543** can be 2 degrees, 2.5 degrees, 3 degrees, 3.5 degrees, 4 degrees, 4.5 degrees, 5 degrees, 5.5 degrees, or 6 degrees. In the illustrated embodiment, the first rotation inhibiting angle is 4 degrees.

The second rotation inhibiting angle **544** can range between 12 degrees and 18 degrees. In some embodiments, the second rotation inhibiting angle **544** can range between 12 degrees and 13 degrees, 13 degrees-14 degrees, 14 degrees-15 degrees, 16 degrees-17 degrees, or 17 degrees-18 degrees. In alternative embodiments, the first rotation inhibiting angle **544** can be 12 degrees, 12.5 degrees, 13 degrees, 13.5 degrees, 14 degrees, 14.5 degrees, 15 degrees, 15.5 degrees, 16 degrees, 16.5 degrees, 17 degrees, 17.5 degrees, or 18 degrees. In the illustrated embodiment, the second rotation inhibiting angle **544** is 16 degrees.

The middle region of the arms **517** can be configured to be received within the void **545** of the rotation inhibiting structures **527**. The axle **502** not only extends entirely through elongated body, but also extends through the void **545** and middle aperture **524**, thereby rigidly supporting both the elongated body of the hanger but also provides an axis of rotation for the arms **517** to rotate about. The combination of the rotation inhibiting structure **527** and the first rotation inhibiting protrusion **541** of the arm **517** forms an overlapping structure. When the truck **500** is in a zero-degree reference angle configuration, the overlapping structure will not be felt or apparent to the rider, however, as the

arms **517** begins to rotate/pivot away from the ground surface, the first rotation inhibiting protrusion and the second rotation inhibiting protrusion will contact the pivot body **506** providing a physical barrier. This physical barrier prevents over rotation of the one or more arms to the point where the wheels **504** contact the bottom surface of the skateboard deck (not shown).

FIG. **20** further illustrates that the front aperture **523** and the rear aperture **525** of each of the arm **517** is configured to receive at least one axles **503**. Each axle **503** is configured to retain a wheel **504**.

Referring again to FIGS. **14-20**, the embodiment of the truck **500** further includes one or more friction reducing element **526** configured to be received within the two middle apertures **524** of the arm **517**. In the case of this embodiment, each friction reducing element is defined by a first part and a second part. The first and second part of the friction reducing element is substantially flanged shape. The first and second part of the friction reducing element share similar elements. Referencing FIG. **19**, the friction reducing element comprises a shoulder portion **548** and a body portion **549**. In many embodiments, the body portion **549** is substantially cylindrical and comprises an inner diameter and an outer diameter. The shoulder portion extends radially outward from outer diameter at one end of the body portion. The first and second parts are mirror images of each other. The first and second friction reducing elements are press fit into opposing sides of the middle aperture **524**. This type of structure and arrangement permits the friction reducing element to be positioned on opposing sides of the arm **517** to beneficially aid in aligning the middle aperture to the arm **517**. This arrangement protects each side of the arm **517** from contacting the internal side walls of the rotation-inhibiting structures minimizing wear due to material galling or fatigue stresses.

With continued reference to FIGS. **14-20**, the pivot body **506** and the pivot tip **507** forms a pivot saddle **505** that is substantially triangular. This type of triangular arrangement extends from the first end **530** of the elongated body **502** and the second end **531** of the elongated body **502**, therefore additionally acting as a structural support mechanism to the elongated body **502**, as stresses imposed on the hanger are distributed across a larger region and allowed to travel over a larger area.

As previously described, the base plate **508** is the component of the truck that couples the elongated body **502**, the wheels **504**, and the pivot saddle **505** to the skateboard deck **511**. The base plate **508** forms a plurality of bolt receiving ports **509**, at least one king pin receiving aperture **516**, and at least one pivot cup receiving port **515**. These receiving ports provides receiving geometries for a plurality of bolts, a king pin, and the pivot tip of the pivot saddle, respectively. Thereby, securing the moving wheel platform or the truck to a given apparatus.

The arrangement of the aforementioned truck components enables individuals riding skateboards or longboards to more efficiently maneuver over cracks in sidewalks as the configuration of the truck components enables the wheels coupled to the elongated body of the hanger to be suspended over a contraction joint (i.e. prevents the wheels from descending into the crack when the user is moving over a contraction joint). Further, this embodiment requires only one arm while still utilizing rotation-inhibiting structures and rotation inhibiting protrusions of the arms to prevents one or more wheels from contacting a bottom portion of the skateboard (i.e. preventing wheel bite). However, presents an alternative wheel arrangement configuration.

A high-speed motion analysis experiment was conducted to analyze the effectiveness of the skateboard truck embodiments to maneuver over sidewalk contraction joints of approximately 1.125 inches wide. Specifically, the embodiment of FIGS. **8-11** was analyzed. The truck is configured to have two or more wheels on the riding (or ground) surface at any given moment. This is in part caused by the length of the arms and wheel arrangement. FIG. **21** illustrates a user riding a skateboard approaching a crack (approximately 1.125 inches in width), at least two wheels engaged with the riding surface, and more particularly all four wheels. FIG. **22** illustrates the forward (or leading) wheel of the skateboard truck descending into the contraction joint and at least two wheels engaged with the riding surface, and more particularly three wheels. FIG. **23** illustrates the leading wheel ascending from the contraction joint onto an adjacent concrete slab, the two wheels attached to the axle that extends through the elongated body are suspended above the contraction joint, and the rear wheel (or trailing wheel) is on the opposing concrete slab. FIG. **24** illustrates the rear wheel (or trailing wheel) entering the contraction joint, however, as shown in all figures at least two wheels are always on the riding surface regardless of how the skateboard truck approaches the contraction joint. This either enables one or more wheels to glide over a contraction joint or minimize wheel interaction with the contraction joint.

EXAMPLE 2

A high-speed motion analysis experiment was conducted to analyze the effectiveness of the skateboard truck embodiments to maneuver over non-level, non-smooth, and uneven surfaces. Specifically, the embodiment of FIGS. **8-11** was analyzed. This study analyzed the velocity of the wheels before and after impact with an instantaneous change in the height of the riding (or ground) surface of 0.5 inch. Two versions of Skateboard Truck II were tested. The first version is in a standard arm ratio (i.e. the first segment of the arm and the second segment of the arm having an equivalent length of 3.5 inches). The second version is an increased arm ratio (i.e. the first segment of the arm is approximately 5 inches and the second segment of the arm is approximately 3.5 inches). Each version of the skateboard truck was analyzed with all wheels having a diameter of 69 mm or 75 mm. It was determined (1) that the velocity of the wheels in the standard arm ratio with wheel diameters of 69 mm decreased approximately 28% after impact with the instantaneous height change (2) that the velocity of the wheels in the standard arm ratio with wheel diameters of 75 mm decreased approximately 27.5% after impact with the instantaneous height change, (3) that the velocity of the wheels in the increased arm ratio with wheel diameters of 69 mm decreased approximately 28.8% after impact with the instantaneous height change, and (4) that the velocity of the wheels in the increased arm ratio with wheel diameters of 75 mm decreased approximately 30.5% after impact with the instantaneous height change. Therefore, both length of the arm (more particularly length of the first segment and second segment) and wheel diameter effect the wheel velocity after impact with a non-level, non-smooth, and/or uneven surface.

Various features and advantages of the disclosures are set forth in the following claims.

Clause 1. A truck comprising: a hanger; the hanger comprising: a cylindrical body; wherein the cylindrical body

31

surrounds a bore or void; a pivot saddle; the pivot saddle further comprises a pivot tip and a pivot body surrounding an aperture; at least two rotation inhibiting structures; an axle; wherein the axle is received within the bore or the void of the cylindrical body of the hanger; an assembly; the assembly comprising: a first arm and a second arm; a first and second auxiliary wheels; wherein: the first and second arms comprises a front region, a middle region, and a rear region; the front region forms a front aperture; the middle region forms a middle aperture; the rear region forms a rear aperture; the two rotation inhibiting structures are adjacent and on opposing sides to the pivot saddle body and spaced from the cylindrical body; the two rotation inhibiting structures are coplanar to each other and/or wherein the middle region of the first and second arms are located in the space between the rotation inhibiting structure and the cylindrical body.

Clause 2. The truck of clause 1, wherein the first arm and the second arm comprises a first end and a second end, and wherein the first end and the second end are substantially planar to one another or at an angle between 178 degrees and 180 degrees.

Clause 3. The truck of clause 1, wherein the first arm and the second arm comprises a first end and a second end, and wherein the first end and the second end are at an angle between 178 degrees and 180 degrees.

Clause 4. The truck of clause 1, wherein the truck is in the nose of a skateboard.

Clause 5. The truck of clause 4, wherein the truck is in the tail of a skateboard.

Clause 6. The truck of clause 1, wherein a third wheel and a fourth wheel are coupled to the axle.

Clause 7. The truck of clause 1, wherein the first wheel, the second wheel, the third wheel and the fourth wheel are in a diamond-shape configuration.

Clause 8. The truck of clause 2, wherein the first end of the first and second arms are shorter in length than the second end of the first and second arms.

Clause 9. The truck of clause 6, wherein the first wheel, the second wheel, the third wheel, and the fourth wheel are the same diameter.

Clause 10. The truck of clause 1, wherein the rotation-inhibiting structure defines a predetermined range of movement.

Clause 11. The truck of clause 10, wherein the predetermined range of movement is between 0 degrees and 35 degrees.

Clause 12. The truck of clause 1, wherein a length of the rotation inhibiting structure is non-circular nor elliptical with a length between 2 to 2.5 inches.

Clause 13. The truck of clause 12, wherein a width of the rotation inhibiting structure is between 0.125 inch and 0.375 inch.

Clause 14. The truck of clause 1, wherein the truck further comprises one or more flange bearings that are housed within the middle aperture of the first and second arms to reduce frictional forces between the cylindrical body of the hanger and the first and second arms.

Clause 15. The truck of clause 14, wherein the flange bearing is comprised of a nylon material.

Clause 16. The truck of clause 3, wherein the truck is in a reverse king pin configuration.

Clause 17. The truck of clause 1, wherein the front aperture, the middle aperture, and the rear aperture are circular.

Clause 18. The truck of clause 1, wherein the rotation-inhibiting structure is solid.

32

Clause 19. The truck of clause 1, wherein the rotation-inhibiting structure is hollow.

Clause 20. The truck of clause 6, wherein the diameter of the first wheel, the second wheel, the third wheel, and the fourth wheel are between 3 and 6 inches.

What is claimed is:

1. A truck comprising:

a hanger; the hanger comprising:

a cylindrical body; wherein the cylindrical body surrounds a bore or void;

a pivot saddle; the pivot saddle further comprises a pivot tip and a pivot body surrounding an aperture;

at least two rotation inhibiting structures;

an axle; wherein the axle is received within the bore or the void of the cylindrical body of the hanger;

an assembly; the assembly comprising:

a first arm and a second arm;

a first auxiliary wheel and a second auxiliary wheel;

wherein:

the first and second arms comprises a front region, a middle region, and a rear region;

the front region forms a front aperture;

the middle region forms a middle aperture;

the rear region forms a rear aperture;

the two rotation inhibiting structures are adjacent and on opposing sides to the pivot body and spaced from the cylindrical body; and

the two rotation inhibiting structures are coplanar to each other and wherein the middle region of the first and second arms are complimentary and located between the rotation inhibiting structure and the cylindrical body.

2. The truck of claim 1, wherein the first arm and the second arm comprises a first end and a second end, and wherein the first end and the second end are substantially planar to one another.

3. The truck of claim 2, wherein the first end of the first and second arms are shorter in length than the second end of the first and second arms.

4. The truck of claim 1, wherein the first arm and the second arm comprises a first end and a second end, and wherein the first end and the second end are at an angle between 178 degrees and 180 degrees.

5. The truck of claim 4, wherein the truck is in a reverse king pin configuration.

6. The truck of claim 1, wherein the truck is in a nose of a skateboard.

7. The truck of claim 6, wherein the truck is in a tail of a skateboard.

8. The truck of claim 1, wherein a third wheel and a fourth wheel are coupled to the axle.

9. The truck of claim 8, wherein the first auxiliary wheel, the second auxiliary wheel, the third wheel, and the fourth wheel are the same diameter.

10. The truck of claim 8, wherein the first auxiliary wheel, the second auxiliary wheel, the third wheel, and the fourth wheel each comprise a diameter, and wherein each diameter of the first auxiliary wheel, the second auxiliary wheel, the third wheel, and the fourth wheel is between 2.7 and 4 inches.

11. The truck of claim 8, wherein the first auxiliary wheel, the second auxiliary wheel, the third wheel and the fourth wheel are in a diamond-shape configuration.

12. The truck of claim 1, wherein the rotation-inhibiting structure defines a predetermined rotational range of movement for the first arm and the second arm.

13. The truck of claim 12, wherein the predetermined rotational range of movement is between 0 degrees and 35 degrees.

14. The truck of claim 1, wherein a length of the rotation inhibiting structure is non-circular nor elliptical with a length between 2 to 2.5 inches.

15. The truck of claim 14, wherein a width of the rotation inhibiting structure is between 0.125 inch and 0.375 inch.

16. The truck of claim 1, wherein the truck further comprises one or more flange bearings that are housed within the middle aperture of the first and second arms to reduce frictional forces between the cylindrical body of the hanger and the first and second arms.

17. The truck of claim 16, wherein the one or more flange bearings are comprised of a nylon material.

18. The truck of claim 1, wherein the front aperture, the middle aperture, and the rear aperture are circular.

19. The truck of claim 1, wherein the rotation-inhibiting structure is solid.

20. The truck of claim 1, wherein the rotation-inhibiting structure is hollow.

* * * * *