

[54] SELF-PROPELLED PERCUSSION UNIT FOR DRIVING CEMETERY MARKERS AND METHOD OF USING SAME

[76] Inventors: David Wilham Fulkerson, 8360 W. Six Mile Road, Northville, Mich. 48167; Lawrence William Smith, 26950 Taft Road, Novi, Mich. 48050

[21] Appl. No.: 625,141

[22] Filed: Oct. 23, 1975

[51] Int. Cl.² E02D 7/08; E04H 13/00

[52] U.S. Cl. 61/53.5; 52/103; 52/115; 173/128

[58] Field of Search 61/53.5; 52/103, 115, 52/116; 173/128, 132, 43; 175/19

[56] References Cited

U.S. PATENT DOCUMENTS

655,377	8/1900	Schmeisser	52/103
1,834,729	12/1931	Pflüger et al.	173/128 X
3,365,004	1/1968	Johansson	173/43 X
3,447,613	6/1969	Lisenby	173/43 X

FOREIGN PATENT DOCUMENTS

473,295 10/1937 United Kingdom 61/53.5

Primary Examiner—Jacob Shapiro
Attorney, Agent, or Firm—Barnes, Kisselle, Raisch & Choate

[57] ABSTRACT

A wheeled, self-propelled tractor has a percussion tool or hammer mounted on its forward end and an impact transmitting means carried on the tractor below the hammer. The impact transmitting means comprises a metal frame having a strong rigid top plate that is struck by the hammer and a downwardly opening cavity in which wood timbers are mounted to transmit the impact from the plate to a cemetery marker. Repeated blows to the marker applied through the impact transmitting means will drive the marker into the ground until it is flush with the ground surface where it will not interfere with mowing. The frame is fastened on the vehicle by a suspension system that includes tension springs which keep the wood timbers in a horizontal plane but permit the frame to move downwardly each time it is struck by the hammer.

20 Claims, 10 Drawing Figures

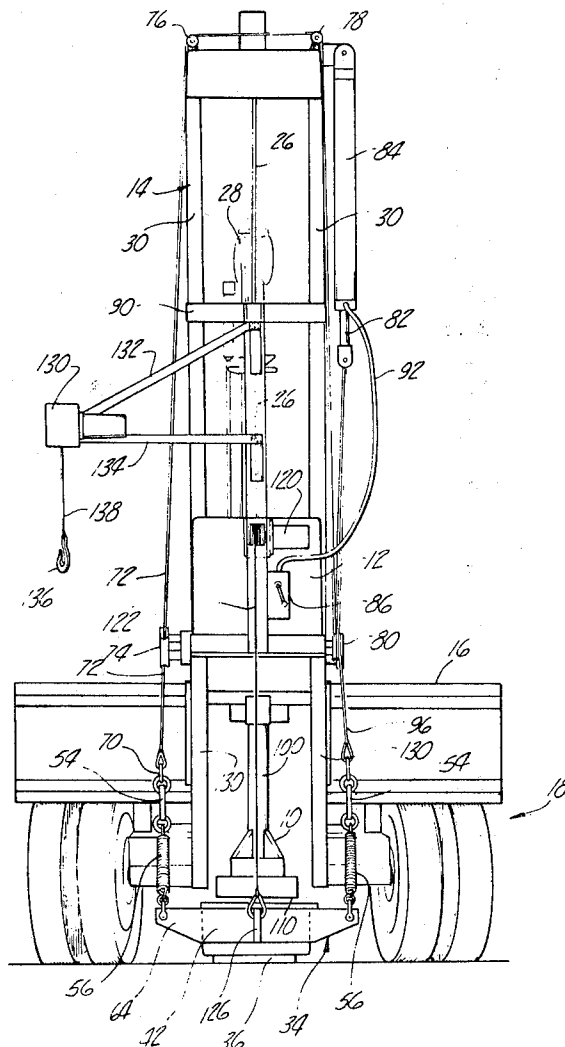
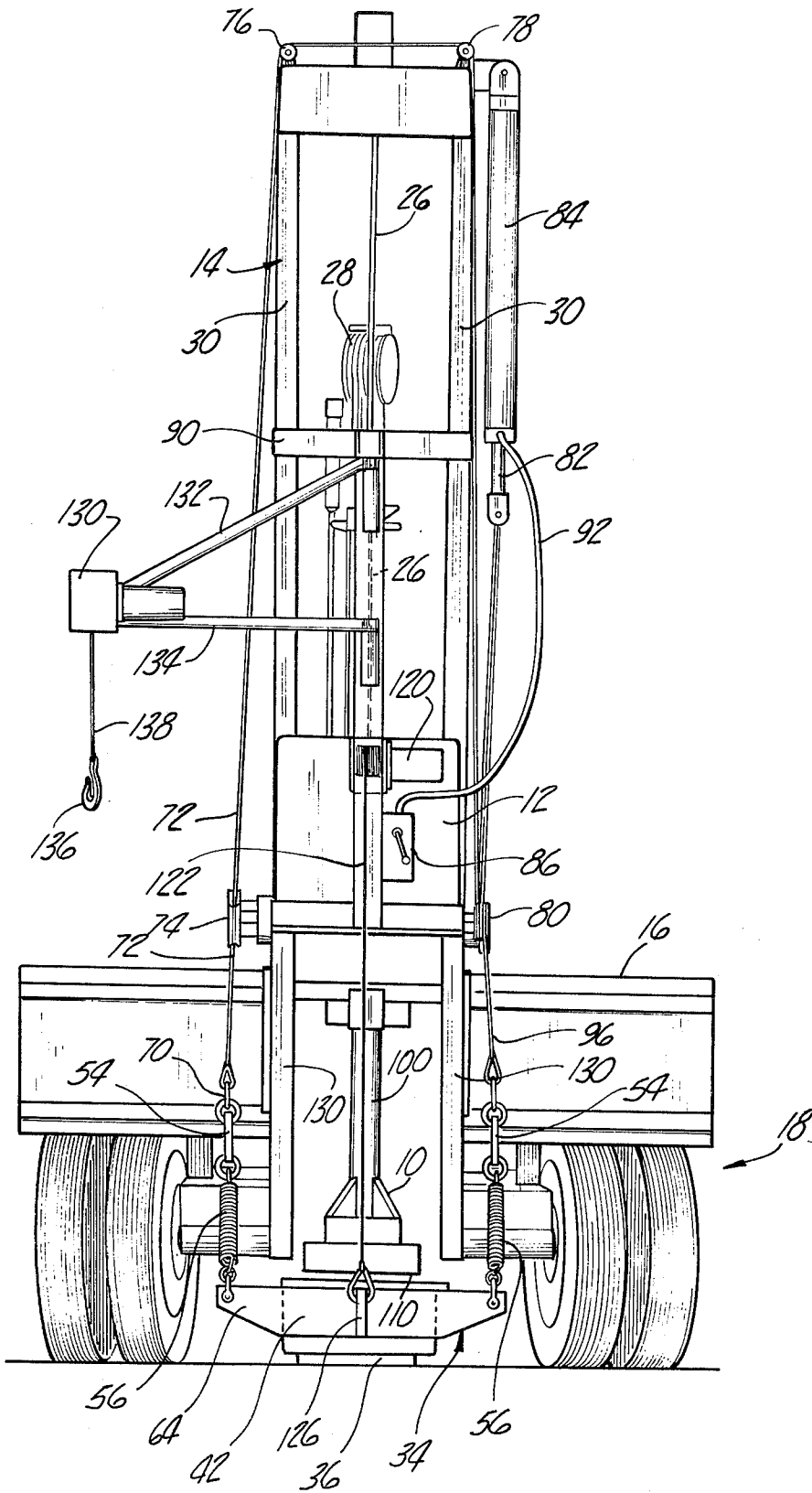
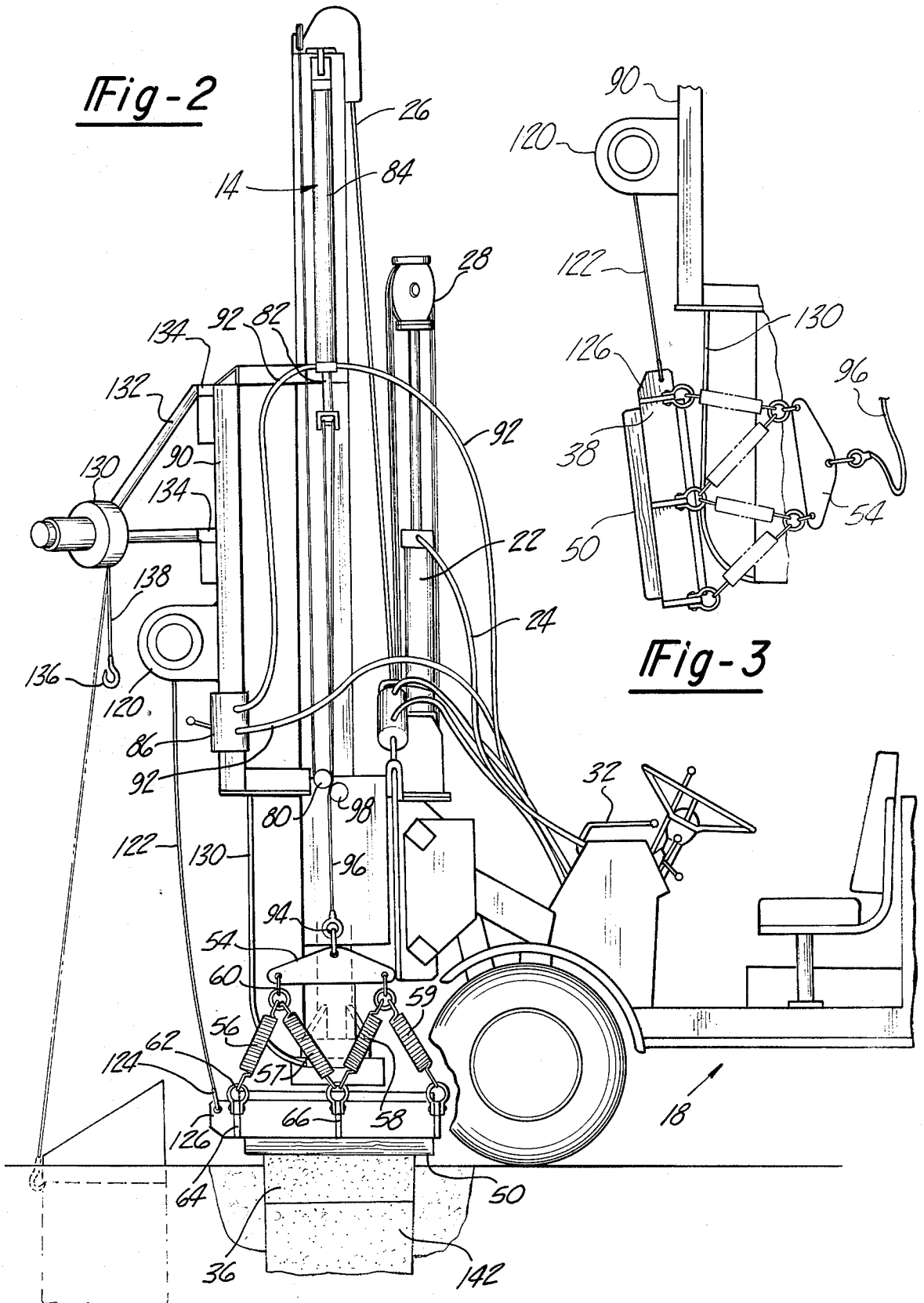

Fig-1





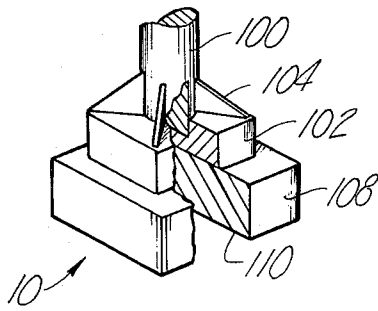

Fig-4

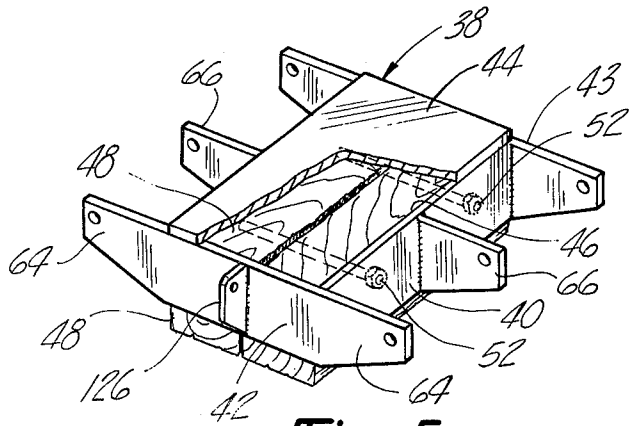

Fig-5

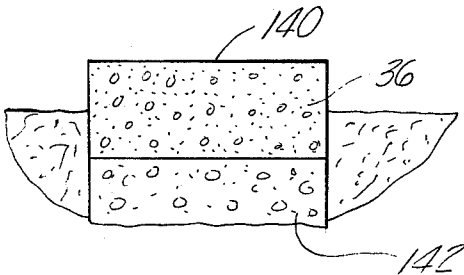

Fig-6

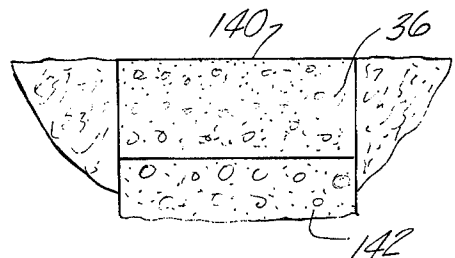

Fig-7

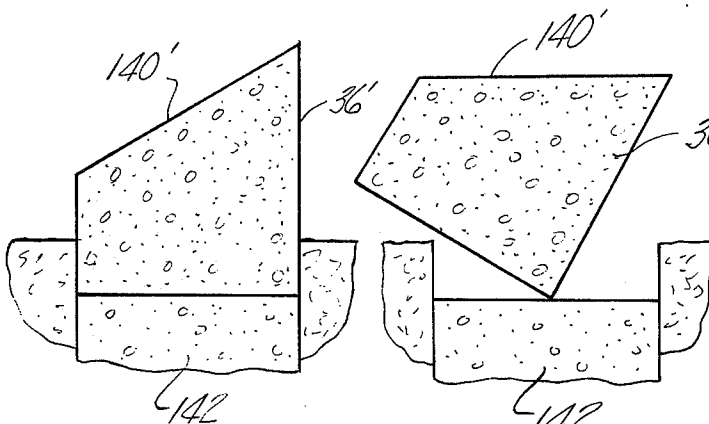

Fig-8

Fig-9

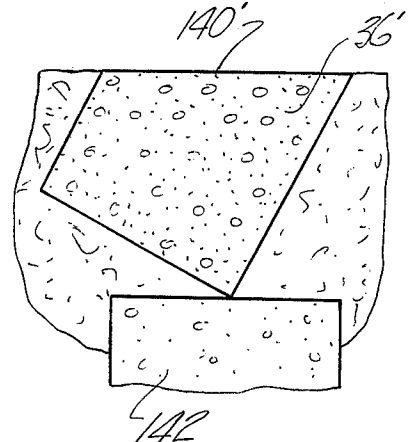

Fig-10

SELF-PROPELLED PERCUSSION UNIT FOR DRIVING CEMETERY MARKERS AND METHOD OF USING SAME

This invention relates generally to a method and apparatus for reducing the cost of maintaining a cemetery and, more particularly, to a self-propelled percussion unit, and method of using same, especially adapted for driving previously installed cemetery markers into the ground so that grass can be cut with a mower running over the cemetery markers with the mower blade operating at a normal cutting height.

In recent years, the cost in maintaining cemeteries has increased dramatically to the point where cemetery maintenance is a real problem. Where cemetery markers were installed projecting above the ground, a self-propelled mower cannot pass over the raised marker when the mower blade is operating in a normal cutting position. The cost to hand trim markers is becoming prohibitive, and mowing costs are substantial if a mower must maneuver around protruding markers. The problem has become so severe that a large number of cemeteries no longer permit a marker to be installed projecting above the ground where it will interfere with a self-propelled mower. Although grass immediately around a grave marker can be controlled by grass killers and the like, this is expensive and still requires that the mower negotiate around the raised markers. The increase in maintenance cost caused by the raised markers has in some cases been sufficient to justify cemetery workers digging up markers and their foundations, deepening the excavation and then reinstalling the foundation and the marker flush with the ground. This manual operation is time consuming and expensive, and the cost to manually relocate the marker flush with the ground can easily be on the order of \$10 to \$20 per marker. This cost is almost prohibitive with large older cemeteries having literally thousands of raised cemetery markers.

The principal object of the present invention is to reduce the cost in maintaining cemeteries that presently have cemetery markers projecting above the ground sufficiently to interfere with a self-propelled mower passing over the marker while it is cutting grass.

A further object of the present invention is to provide a self-propelled percussion unit having a specially constructed impact transmitting arrangement that rapidly and effectively drives cemetery markers flush with the ground at relatively low cost, without damaging the marker, and in a relatively short time compared to prior manual marker relocation techniques; that is usable with markers of various different configurations; and/or that can be constructed by relatively simple modification of existing percussion units presently used for other purposes.

A further object of the present invention is to provide a method for relocating cemetery markers of the type referred to above in a manner that is simple, usable with a wide variety of marker configurations, relatively low in cost by comparison to prior manual techniques, that will not damage the markers and/or that can be readily implemented by relatively simple modification of existing percussion units presently used for other purposes.

Other objects, features and advantages of the present invention will become apparent in connection with the following description, the appended claims and the accompanying drawings in which:

FIG. 1 is a front view of a self-propelled percussion unit for driving cemetery markers into the ground according to the present invention;

FIG. 2 is a side elevational view of the front portion of the self-propelled unit shown in FIG. 1;

FIG. 3 is a fragmentary side view showing an impact transmitting means of the present invention, swung forwardly and upwardly from its position illustrated in FIG. 2;

FIG. 4 is a perspective view, partly broken away and in section, of a lower end of a hammer on the percussion unit;

FIG. 5 is a perspective view, partly broken away and in section, of the impact transmitting means; and

FIGS. 6-10 are views schematically illustrating the manner in which two different types of markers and their foundations can be driven into the ground according to the present invention.

Referring more particularly to the drawings, a hammer 10 is carried on the lower end of a heavy weight 12 that is vertically reciprocally mounted on a hammer tower 14 that is carried for transverse positioning on a frame 16 mounted on the front of a self-propelled wheeled tractor 18. Except for minor modification of the hammer 10, per se, and the hydraulic control, the arrangement and construction of the weight 12, tower 14, frame 16 and tractor 18 may be substantially identical to that described and disclosed in U.S. Pat. No. 3,172,483, granted March 9, 1965, which patent is hereby incorporated by reference thereto. Self-propelled percussion units of this general type are well known for a multiplicity of uses, for example, tamping fills, cutting and breaking pavement, driving posts and pilings, and the like, and are available from several manufacturers including the Arrow Manufacturing Company of Denver, Colorado, to which the aforementioned U.S. Pat. No. 3,172,483 was assigned. Such prior art percussion units include a hydraulic system (not shown) which, under the control of the operator, controls a hydraulic cylinder 22 (via hydraulic hoses 24) which in turn raises weight 12 via a pulley arrangement 28 and cable 26 that is connected to the top of weight 12. When the operator initially energizes cylinder 22, cable 26 is retracted to move weight 12 upwardly on opposed ways 30 to a raised position, generally anywhere from an inch or so up to several feet, for example, 8 feet. At this point, the hydraulic system automatically releases weight 12 so that it falls freely to develop a high impact force at hammer 10. Typically, weight 12 might be 1000 pounds.

In conventional percussion units, the controls of the hydraulic systems are arranged such that, once the operator initiates the operation, the cylinder will be cycled repeatedly until the operator deactivates the control. According to one aspect of the present invention, the hydraulic control is modified so that the weight 12 and hammer 10 are raised and dropped only once each time the operator actuates the control, as by control handle 32. This is a very simple modification that can be accomplished by by-passing the automatic sequencing valve. Aside from this minor modification and the modification of the hammer as will be described, the above described percussion unit may be otherwise substantially identical to the aforementioned commercially available units. As set forth in greater detail in the aforementioned U.S. Pat. No. 3,172,483, the horizontal position of the vertical hammer tower 14 can be adjusted transversely of the vehicle by suitable means (not

shown) on frame 16, and the tower can also be pivoted sideways on a first horizontal axis or forwardly and rearwardly on another horizontal axis so that the direction of the impact provided by hammer 10 can be selected.

According to the present invention, the commercially available percussion unit is modified by adding an impact transmitting member 34 that can be raised and lowered independently of hammer 10 and can be positioned below hammer 10 on top of a cemetery grave marker 36. More particularly, the member 34 comprises a generally rectangular frame 38 having a pair of side or end plates 40, front and rear plates 42, 43 and top plate 44. The plates are securely welded together to form a downwardly opening cavity 46 in which wood timbers 48 are mounted so as to fill the cavity and project below plates 40, 42, 43 and form a flat, lower cushion surface 50 for engaging directly against marker 36. The frame 38 and particularly the top plate 44 must be rigid, strong and hard to withstand repeated severe impact forces from hammer 10. In one embodiment of the present invention, top plate 44 was a 2-inch thick steel plate, 26 inches in depth (in a direction longitudinally of the wheeled tractor 18) and 22 inches wide (in a direction transversely of the tractor 18). Plates 40, 42, 43 are formed of 1-inch thick steel plate, 4 inches tall so that the cavity 46 can accommodate two 8 × 10 × 24 wood timbers of generally rectangular cross section with the upper surface of the timbers bottomed against the lower surface of top plate 44. Although the timbers can be maintained in the cavity by making them slightly oversized and driving them in place, preferably they are held in place on the frame 38 by a pair of bolts 52 that extend transversely through the timbers and the side plates 40. Although various types of wood timbers could be used, it has been found that elm timbers operate very effectively since, although very soft in comparison to steel, elm is a relatively hard wood that will withstand repeated impact against the marker without splitting and splintering.

Frame 38 is connected to a pair of triangular hanger plates 54 located, respectively, at opposite sides of tower 14 by means of four tension springs 56, 57, 58, 59 at each plate 54 as best shown in FIG. 2. The front spring 56 is fastened at its upper end to the front of plate 54 by rings 60 and at its lower end via ring 62 to a laterally extending lug 64 on the front plate 42. The rear spring 59 is similarly fastened to the rear of hanger plate 54 and the rear wall 43. The center two springs 57, 58 are connected at their top ends, respectively, to the front and rear of hanger plate 54 and at their lower ends to a lug 66 welded on the sidewall 40 midway between the front and rear walls. An identical spring arrangement is provided at the opposite side of frame 38. As will later be more apparent, the spring arrangement insures that the frame can maintain a horizontal position when placed against the top surface of markers having different configurations and also permits the frame to move downwardly against the tension of the springs when the plate 44 is impacted by hammer 10.

The hanger plate 54 at the left side of tower 14 as viewed in FIG. 1 is pivotally connected at 70 to the lower end of a cable 72 which passes upwardly in a straight run over an idler pulley 74 with the cable continuing upwardly and over a pair of pulleys 76, 78 at the top of tower 14, and then downwardly around a further pulley 80 (FIG. 2) and then back upwardly where it is fastened at its other end to the piston 82 of a hydraulic

cylinder 84 mounted on the hammer tower 14. Cylinder 84 is controlled by a hand operated valve 86 mounted on a front frame 90 carried on tower 14. Suitable hydraulic interconnections can be provided as illustrated by the hydraulic lines 92 interconnecting the cylinder 84, the control valve 86 and the hydraulic pressure system (not shown) so that a worker can actuate cylinder 84 while he is standing in front of or at the side of tower 14 to raise and lower frame 38. In a similar fashion, the hanger plate 54 at the right of tower 14 as viewed in FIG. 1 is connected at 94 to the lower end of a cable 96 that passes upwardly between an idler pulley 98 and a second groove on the pulley 80 with the upper end of cable 96 being connected to piston 82. With this arrangement, when piston 84 is actuated, cables 72, 96 move in unison to raise and lower frame 38 while the lower surface 50 of the timbers stays in substantially a horizontal plane.

Referring now to FIGS. 1, 2 and 4, as indicated earlier, the hammer portion of the commercially available percussion units has been modified slightly according to the present invention to better withstand repeated battering against the top plate 44 of the frame 38. The weight 12 is fastened at its lower end to a vertical column 100 that, in turn, has its lower end welded in a 2-inch thick steel block 102 with four reinforcing struts 104 being welded to column 100 and block 102 at positions equally spaced circumferentially about the column to further reinforce the hammer 10. Block 102 is, in turn, welded to a larger 2-inch thick steel block 108. Block 108 has a cross section in a horizontal plane of about 10 inches by 10 inches and has a flat lower face 110 for impacting against the top face 44 on the frame 38. Since the horizontal area of block 108 is substantially smaller than the area of plate 44, frame 38 can be manipulated so that hammer 10 strikes plate 44 at selected locations. On the other hand, plate 44 distributes the concentrated impact of hammer 10 over larger areas for impacting marker 36. In this regard, the area of timber surface 50 is slightly larger than a typical cemetery marker.

Also mounted on frame 90 slightly forward of the tower 14 is an electric motor-driven wench 120 having a cable 122 that is pivotally fastened at 124 on a lug 126 welded on the front plate 42. A pair of curved guide rails 130 are mounted at their lower end on tower 14 and at their upper end on frame 90 so as to project slightly forward of the hammer 10 and guide the frame 38 forwardly when it is raised upwardly by retracting cable 122. As shown in FIG. 3, the frame 38 can be raised completely out of the way of hammer 10 as may be required during travel of tractor 18 or so that hammer 10 can be used for other purposes. With some lightweight markers such as sandstone, limestone or deteriorated markers, or in other situations justifying such procedure in the opinion of the operator, the marker can be removed and the foundation 142 driven down with hammer 10 and then the stone replaced. Additionally, cable 122 can be used to slightly tilt the frame 38 if required for driving a particular type of cemetery marker.

A further electric wench 130 is also mounted on the frame 90 by means of struts 132 which are pivotally connected to the frame 90 and 134. A hook 136 is fastened at the lower end of a cable 138 of wench 130. In working with cemetery markers, it is frequently convenient to have a separate powerdriven wench that can be used to assist the workman in dislocating, reorienting or

even moving the marker as illustrated generally in broken lines in FIG. 2.

In using the self-propelled unit of the present invention, the tractor 18 is driven to the site of a marker 36 (FIGS. 1, 6 and 7) and positioned so that the hammer 10 is located directly above the center of the top surface 140 of the marker. Usually, the markers will be in a row extending the direction of travel of tractor 18 so that the long dimension of the marker 36 corresponds to the long dimension of frame 38 and tractor 18 straddles the row of markers. As illustrated schematically in FIG. 6, the marker extends or projects upwardly above the ground surface to a height where it would interfere with the passage of a lawn over the marker when the mower blade is operating at a normal cutting height. Flat rectangular markers of the type shown in FIG. 6 may be 12 inches by 24 inches, made of granite or marble, and typically project from 4 to 6 inches above the ground but could be as high as say 14 inches. As also illustrated in FIG. 6, marker 36 is typically installed on top of a foundation 142 which would have to be dug up manually if one attempts to relocate the marker 36 manually. The exact nature and arrangement of the foundation 142 varies greatly depending, in part, for example, on location, the practice at the cemetery involved, soil conditions and the year in which it was originally installed. The foundation might be a concrete pad 6 to 8 inches thick or, in some instances, it can be a concrete footing that extends a substantial depth of up to 42 inches, for example.

When hammer 10 is positioned over marker 36 and frame 38 centered over the marker, and hence centered with respect to the hammer, the frame is lowered by lowering cables 72, 96 until the bottom surface 50 of timbers 48 engages with the top surface 140 of the marker. In the preferred mode of operation, the cables are adjusted so that the springs 56-59 are in tension and supporting some of the weight of the frame and so that plate 44 is horizontal or parallel with the bottom surface 110 of hammer block 108. This insures that the hammer 10 will strike the top plate 44 over the entire interface therebetween; and if the marker is tipped slightly, the impact will tend to level the top surface of the marker as it is driven downwardly. After the frame is positioned, the operator on tractor 18 actuates handle 32 to move hammer 10 and weight 12 to their raised position, at which point the weight is automatically released. The impact of hammer 10 on plate 44 is transmitted via timbers 48 to marker 36, driving it and foundation 142 downwardly into the ground. After each impact, the operator on the tractor will again actuate the cylinder 84 to raise the weight 12 and hammer 10 and repeatedly impact frame 38 and marker 36 until the foundation and marker are driven downwardly to a level where the top surface 140 is substantially flush with the ground.

A typical marker that might extend 4 to 6 inches above the ground can be pounded flush with the ground with 1 to 5 impacts by hammer 10 which will take only a matter of seconds or, at most, several minutes. The unit is preferably manned by an operator on tractor 18 to operate hammer 10 via cylinder 22 and a second workman standing in front or at the side of the percussion unit so that he can make sure that the frame 38 remains properly positioned as the marker is driven flush with the ground. The workman standing at the front of the unit can, via valve 86, progressively lower cables 72, 96 to maintain timbers 48 horizontal and in engagement with the marker and true to the hammer

while keeping the springs 56-59 slightly tensioned. As indicated earlier, if a marker is slightly tilted, by keeping the frame 38 horizontal, the impact will be concentrated at the high side of the marker and will, as the marker is driven into the ground, level the top surface of the marker. Where this is not fully accomplished, as the marker is driven downwardly, the operator on the tractor can change the vertical orientation of the tower 14 and the workman at the front of the percussion unit can maneuver the frame 38 so that the impact is transmitted directly to the high side of the marker. This technique is also useful where the terrain is not level and it is desired to have the top surface of the marker conform to the terrain. After one marker is pounded into the ground, tractor 18 is driven to the next marker and it is pounded into the ground in the manner described hereinabove.

Referring to FIGS. 8, 9 and 10 which illustrate another type of cemetery marker 36' having an inclined top surface 140', the hook 136 and cable 138 can be used to lift or raise the front edge of the marker 36 and tilt it backward to the position illustrated in FIG. 9. The workman can then center the tilted marker 36' and align it with other markers. With the marker tipped as shown in FIG. 9, the workman lowers the frame 38, while keeping it horizontal, and lets it rest on the top surface 140'. In most cases, the weight of the frame and the tension in springs 56-59 are such that marker 36' will stay in the tilted orientation as it is driven downwardly until the top surface 140' is substantially flush with the ground as illustrated in FIG. 10. When a marker is tipped as illustrated in FIGS. 8-10, the marker 36' and foundation 142' may crumble or fracture slightly at the interface therebetween. However, it has been found that this does not usually cause any visible damage to the marker once it is in place. It is usually desirable to back fill under the bottom face of a tipped marker 36' before it is driven to prevent settling.

Although the operation of the percussion unit has been described hereinabove in two examples wherein the springs 56-59 at both sides of the frame 38 are preferably kept tensioned, it will be apparent that the principal purpose of the springs is to permit the workmen to keep the frame 38 horizontal and trued relative to the hammer 10, which, in turn, will tend to drive the high side of the marker downwardly, leveling the marker and insuring that the full force of the hammer 10 strikes the plate 44 directly. This also minimizes stresses on hammer 10 and tends to reduce secondary impacts that might be caused by a wobble at the frame. In order to achieve these objectives, depending on the circumstances, it may be necessary or desirable to permit the springs, at least at one side of the frame, to relax. On the other hand, where the top surface of the marker is substantially level before it is driven, the marker could be driven with the springs slack. However, it is preferred to keep the springs 56-59 at least slightly tensioned since the springs also tend to prevent the frame 38 from becoming misaligned with the marker.

One of the more important aspects of the present invention is the recognition and implementation thereof that a percussion tool can effectively drive cemetery markers flush with the ground in a simple and effective manner without damage to the marker. Before the practicality of the present invention was established by extensive testing, it was not at all certain that markers could be driven by brute force without substantial damage, if not complete fracturing, of the marker. However, based on the experience of driving hundreds of

markers, it is estimated that the breakage is perhaps about one percent or less. Breakage is more likely to occur with slant-faced markers such as that shown in FIGS. 8-10, particularly where the marker is high or the angle of the slant face is great. Generally, sandstone and limestone markers should be removed and the foundations driven separately. Breakage can be reduced by exploring the area under the marker and foundation with a long steel rod if the marker does not move with a couple of blows. If the foundation bottoms on a large buried object, such as a large rock or vault, it may then be necessary to reposition the marker manually; but this does not occur very often.

Another important feature of the present invention is that the use of a wooden cushioning pad provided by timbers 48 eliminates scarring of face 140 of the marker 36 which would, of course, be undesirable. Additionally, the cushioning effect of the soft wood distributes the impact force over the entire surface of the marker to minimize fracturing the marker. The construction described hereinabove has proved very effective in driving numerous different configurations of markers without scarring, fracturing or otherwise damaging the markers.

Although various types of percussion tools capable of driving a hard blow could be used, a percussion tool having a heavy weight on the order of 1000 pounds is preferred and can provide the necessary driving force for a wide variety of conditions. The specific height to which weight 12 is lifted and the number of impacts depends on a number of factors including soil types and soil conditions, principally moisture content. By way of further illustration, when driving a marker and its associated foundation in moist loam soil, weight 12 might be lifted only 1 to 4 inches and just slightly higher for sand, for example, 1 to 6 inches. In heavier soils, weight 12 might be lifted from 1 inch to 2 feet in the case of sandy clay and from 1 inch to 4 feet in the case of clay. Hence, generally speaking, the impact will be the equivalent of dropping a 1000-pound weight a distance in the range of from 4 inches to 2 feet. A lighter weight, for example, a 500-pound weight, raised a higher distance could be used; but the heavier 1000-pound weight is preferred to reduce bouncing and secondary impact between hammer 10 and plate 44 and between timbers 48 and marker 36.

The present invention also contemplates mounting frame 38 on tower 14 by means other than a cable-spring suspension system. For example, frame 38 could be mounted on tower 14 by hydraulic cylinders arranged to constantly urge frame 38 downwardly on the marker. However, the cable-spring arrangement is preferred because it allows the operator flexibility in positioning frame 38 relative to the marker and hammer 10 and it can absorb the shock associated with an impact without unnecessary stress on the suspension system. Although a front-mounted percussion unit has been described, it will be understood that rear-mounted units could also be used.

It is estimated that in areas of low labor costs, a marker can be driven into the ground using the method and apparatus of the present invention at a cost that would be equal to about the cost to trim the marker for a two or three year period. In higher labor cost areas, the markers can be driven flush with the ground with the present invention at approximately the same cost to hand trim the markers over one season. Of course, once the marker is driven flush with the ground, maintenance

costs are reduced substantially since the cemetery can be kept neat appearing with self-propelled mowers that can pass over the markers with the cutting blade operating at a normal cutting height of say about 2 to 4 inches.

It will be understood that a self-propelled percussion unit for driving cemetery markers and method of using same has been described hereinabove for purposes of illustration and is not intended to indicate limits of the present invention, the scope of which is defined by the following claims.

We claim:

1. The method of reducing maintenance costs at a cemetery having a plurality of grave markers associated with respective burial graves, said markers protruding above the ground surface to an extent sufficient to interfere with the passage of a lawn mower over said markers with the mower blade operating at normal grass cutting heights comprising creating a first downwardly directed impact force distributed over a first area, converting said first force into a second downwardly directed force by a hard first impact against force transmitting means and by distributing said first force over a second area of said force transmitting means, and applying said second force at said force transmitting means directly to a first marker by an impact softer than said first impact and then repeatedly impacting said first marker in the foregoing manner until said marker is driven downwardly into the ground to a level such that it will not interfere with the passage of a lawn mower over said first marker with its mower blade operating at normal cutting heights.

2. The method set forth in claim 1 wherein said second area is greater than said first area and is on the order of a third area generally corresponding to the area in a horizontal plane of said first marker.

3. The method set forth in claim 1 wherein said first downwardly directed impact force is created approximately equal to the force created by dropping a 1000-pound weight a distance of at least 6 inches.

4. The method set forth in claim 1 wherein said first force is created by dropping a weight of approximately 1000 pounds a distance of at least approximately 6 inches.

5. The method set forth in claim 1 wherein the remaining plurality of markers are driven downwardly into the ground by recreating said first and second forces and impacting each respective marker in the aforesaid manner.

6. The method set forth in claim 5 implemented by a self-propelled wheeled vehicle carrying a percussion tool and said force transmitting means with said first force being created by said percussion tool, said first force being converted to said second force by said force transmitting means, and wherein said plurality of markers are driven by positioning said percussion tool above said first marker, positioning said force transmitting means in the space between said first marker and said percussion tool with said force transmitting means engaged with said first marker, and then repeatedly striking said force transmitting means with said percussion tool while said force transmitting means is engaged with said first marker.

7. The method set forth in claim 6 wherein each of said plurality of markers are driven into the ground by driving said first marker into the ground in the aforesaid manner and then moving said self-propelled vehicle to a second marker, positioning said percussion tool above said second marker, positioning said force transmitting

means in the space between said second marker and said percussion tool with said force transmitting means engaged with said second marker, and then repeatedly striking said force transmitting means with said percussion tool while said force transmitting means is engaged with said second marker.

8. The method set forth in claim 1 wherein said first force is created by a steel percussion tool, said first force is converted into said second force by impacting said steel percussion tool against a steel plate, and wherein said impact to said first marker is transmitted directly from said steel plate to said marker by positioning material softer than steel directly between said plate and said marker.

9. The method set forth in claim 1 wherein said first force is created by a steel percussion tool, said first force is converted into said second force by impacting said steel percussion tool against a steel plate, and wherein said impact to said first marker is transmitted directly from said steel plate to said marker by positioning a wooden cushioning pad between said plate and said first marker.

10. The method set forth in claim 1 implemented by means of a mechanized percussion tool, said force transmitting means being disposed between said percussion tool and said first marker, and wherein said first marker has a top surface that is substantially flat and lies in a horizontal plane, and wherein said method further comprises positioning said force transmitting means directly on said flat horizontal surface and then impacting said force transmitting means with said steel percussion tool.

11. The method set forth in claim 10 wherein said force transmitting means is resiliently supported relative to said ground surface in engagement with said top surface so that top and bottom flat faces on said force transmitting means are disposed in horizontal planes and said force transmitting means is free to move downwardly against a resilient force with said marker upon impact by said percussion tool.

12. The method set forth in claim 11 implemented by means of a vertically movable support interconnected with said force transmitting means by means of springs and wherein said support means is progressively lowered as said marker is driven into the ground by repeated impact of said percussion tool with said force transmitting means.

13. The method set forth in claim 1 implemented by means of a mechanized percussion tool, said force transmitting means being disposed between said percussion tool and said first marker, and wherein said first marker has a top surface that is inclined vertically so that the upper portion of said first marker has an area substantially less than said second area and wherein said method further comprises positioning said force transmitting means directly on said projecting upper portion and then impacting said force transmitting means with said steel percussion tool while resiliently maintaining said force transmitting means in engagement with said marker and simultaneously maintaining flat top and

bottom surfaces of said force transmitting means in substantially horizontal planes.

14. The method set forth in claim 1 wherein said marker initially projects above the ground surface a distance of at least about 4 inches and wherein said marker is impacted repeatedly until it projects above the ground less than 2 inches.

15. The method set forth in claim 1 further comprising exploring the area in the ground beneath said marker before said marker is driven substantially flush with the ground to determine whether a buried obstruction will interfere with driving said marker flush with the ground.

16. In a method of making previously installed cemetery markers substantially flush with the ground so as not to interfere with the passage of a lawn mower over said markers when the mower blade is operating at normal cutting heights comprising providing a ground-engaging vehicle having a percussion tool mounted thereon that is capable of providing a downwardly directed driving force approximately at least as great as the force provided by dropping a 1000-pound weight a distance of at least 6 inches, moving said vehicle to a position where said percussion tool is located directly over a first cemetery marker, disposing between said tool and said marker a force transmitting means carried on said vehicle and arranged and disposed so as to be impacted by said tool and transmit said impact to said first marker, then repeatedly impacting said force transmitting means with said tool until said first marker is driven downwardly substantially flush with the ground, and then moving said vehicle to a second marker and repeating the driving steps previously recited to drive said second marker downwardly until it is substantially flush with the ground.

17. The method set forth in claim 1 further comprising the step of passing a lawn mower over said first marker with its mower blade operating at normal cutting heights.

18. The method set forth in claim 1 wherein said grave markers are made of stone-like material such as granite, marble, sandstone, limestone or the like.

19. In a method of making previously installed cemetery markers substantially flush with the ground so as not to interfere with the passage of a lawn mower over said markers when the mower blade is operating at normal cutting heights comprising providing a ground-engaging vehicle means having a mechanized percussion tool mounted thereon that provides a downwardly directed driving force, moving said vehicle means to a first position at a first cemetery marker, pounding said first marker substantially flush with the ground by means of said percussion tool, and then moving said vehicle means to a second position at a second marker and then pounding said second marker substantially flush with the ground by means of said percussion tool.

20. The method set forth in claim 19 wherein said markers are pounded substantially flush with the ground by transmitting downwardly directed driving forces from said percussion tool to said markers through impact cushioning means.

* * * * *

UNITED STATES PATENT OFFICE
CERTIFICATE OF CORRECTION

PATENT NO. : 4,051,684
DATED : October 4, 1977
INVENTOR(S) : David Wilham Fulkerson and Lawrence William Smith

It is certified that error appears in the above-identified patent and that said Letters Patent are hereby corrected as shown below:

Column 4, line 67, delete "powerdriven" and insert
--power-driven--.

Column 5, line 60, delete "unti" and insert --unit--.

Column 9, claim 10, line 33, before "percussion" delete "steel".

Column 9, claim 13, line 60, before "percussion" delete "steel".

Signed and Sealed this

Seventh Day of March 1978

[SEAL]

Attest:

RUTH C. MASON
Attesting Officer

LUTRELLE F. PARKER
Acting Commissioner of Patents and Trademarks