



(12) **United States Patent**  
**Ling et al.**

(10) **Patent No.:** **US 9,577,886 B2**  
(45) **Date of Patent:** **\*Feb. 21, 2017**

(54) **METHOD AND SYSTEM FOR SERVICE GROUP MANAGEMENT IN A CABLE NETWORK**

(71) Applicant: **Maxlinear, Inc.**, Carlsbad, CA (US)

(72) Inventors: **Curtis Ling**, Carlsbad, CA (US);  
**Sridhar Ramesh**, Carlsbad, CA (US);  
**Timothy Gallagher**, Carlsbad, CA (US)

(73) Assignee: **Maxlinear, Inc.**, Carlsbad, CA (US)

(\*) Notice: Subject to any disclaimer, the term of this patent is extended or adjusted under 35 U.S.C. 154(b) by 0 days.

This patent is subject to a terminal disclaimer.

(21) Appl. No.: **15/228,703**

(22) Filed: **Aug. 4, 2016**

(65) **Prior Publication Data**

US 2016/0344589 A1 Nov. 24, 2016

**Related U.S. Application Data**

(63) Continuation of application No. 13/948,444, filed on Jul. 23, 2013, now Pat. No. 9,419,858.

(60) Provisional application No. 61/674,742, filed on Jul. 23, 2012.

(51) **Int. Cl.**

**H04L 12/24** (2006.01)  
**H04B 17/318** (2015.01)  
**H04L 27/26** (2006.01)

(52) **U.S. Cl.**

CPC ..... **H04L 41/0823** (2013.01); **H04B 17/318** (2015.01); **H04L 27/2602** (2013.01)

(58) **Field of Classification Search**

CPC ..... H04L 41/0893; H04L 1/0017; H04L 25/03343; H04L 1/0009; H04L 1/0026  
See application file for complete search history.

(56) **References Cited**

U.S. PATENT DOCUMENTS

5,563,918 A \* 10/1996 Waldschmidt ..... H04B 17/20 375/267  
6,275,483 B1 \* 8/2001 Papasakellariou . H04B 1/70753 370/335  
6,421,327 B1 \* 7/2002 Lundby ..... H04W 52/24 370/310  
6,560,225 B1 \* 5/2003 Czajkowski ..... H04L 12/6418 370/356

(Continued)

*Primary Examiner* — Dung B Huynh

(74) *Attorney, Agent, or Firm* — McAndrews, Held & Malloy

(57) **ABSTRACT**

A cable modem termination system (CMTS) may determine, for a plurality of cable modems served by the CMTS, a corresponding plurality of SNR-related metrics. The CMTS may assigning the modems among a plurality of service groups based on the SNR-related metrics. For any one of the modems, the CMTS may configure physical layer communication parameters to be used by the one of the modems based on a SNR-related metric of a service group to which the one of the modems is assigned. The physical layer communication parameters may include one or more of: transmit power, receive sensitivity, timeslot duration, modulation type, modulation order, forward error correction (FEC) type, and FEC code rate. The CMTS and the modems may communicate using orthogonal frequency division multiplexing (OFDM) over a plurality of subcarriers, and the physical layer communication parameters may be determined on a per-subcarrier basis.

**18 Claims, 7 Drawing Sheets**

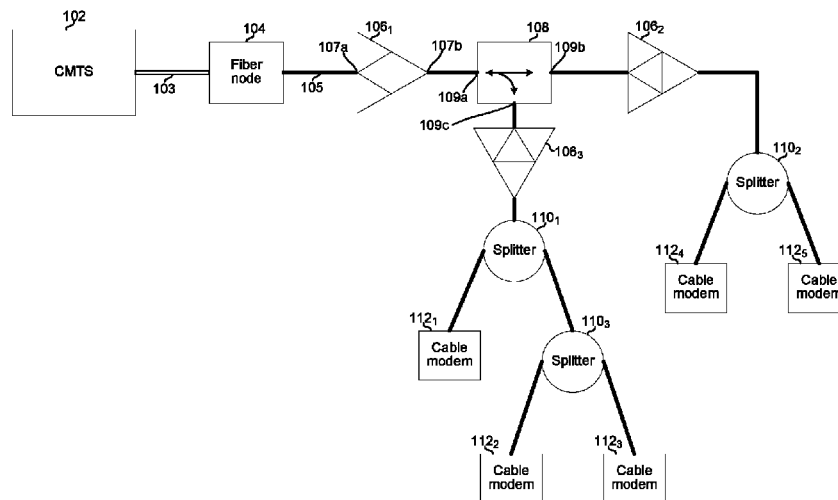

(56)

References Cited

U.S. PATENT DOCUMENTS

6,891,858	B1 *	5/2005	Mahesh	.....	H04L 1/0017	370/235	2007/0253388	A1 *	11/2007	Pietraski	.....	H04J 13/00	370/338
6,898,755	B1 *	5/2005	Hou	.....	H04L 1/0003	370/282	2009/0016420	A1 *	1/2009	Kwak	.....	H04L 5/0048	375/227
7,761,049	B2 *	7/2010	Zeng	.....	G01V 1/223	370/252	2009/0040942	A1 *	2/2009	Yang	.....	H04L 12/2602	370/253
8,488,514	B2 *	7/2013	Cai	.....	H04W 36/30	370/315	2009/0215403	A1 *	8/2009	Currivan	.....	H04B 1/71	455/69
8,743,933	B2 *	6/2014	Prodan	.....	H04L 5/1446	370/210	2009/0219856	A1 *	9/2009	Richardson	.....	H04W 72/044	370/328
9,025,954	B2 *	5/2015	Fang	.....	H04L 12/2801	370/210	2010/0002575	A1 *	1/2010	Eichinger	.....	H04L 5/0046	370/210
2002/0062486	A1 *	5/2002	Park	.....	H04L 12/2801	725/111	2010/0172316	A1 *	7/2010	Hwang	.....	H04L 5/0007	370/330
2002/0186459	A1 *	12/2002	DeGrange, Jr.	....	H04B 10/0775	359/341.4	2011/0051607	A1 *	3/2011	Begen	.....	H04L 41/083	370/252
2003/0002450	A1 *	1/2003	Jalali	.....	H04B 7/0434	370/294	2011/0188852	A1 *	8/2011	Stodola	.....	H04J 14/02	398/27
2003/0043732	A1 *	3/2003	Walton	.....	H04L 1/0009	370/208	2011/0306380	A1 *	12/2011	Zavadsky	.....	H04W 24/02	455/522
2003/0053419	A1 *	3/2003	Kanazawa	.....	H04L 1/20	370/252	2012/0269242	A1 *	10/2012	Prodan	.....	H04L 5/1446	375/222
2003/0177502	A1 *	9/2003	Kolze	.....	H04N 21/6118	725/111	2013/0021931	A1 *	1/2013	Kim	.....	H04L 1/0003	370/252
2003/0199283	A1 *	10/2003	Busch	.....	H04W 52/12	455/513	2013/0024753	A1 *	1/2013	Masuda	.....	H04L 1/005	714/799
2003/0223481	A1 *	12/2003	Jones	.....	H04L 1/24	375/222	2013/0100843	A1 *	4/2013	Croak	.....	H04L 43/08	370/252
2003/0236071	A1 *	12/2003	Ito	.....	H04L 1/0015	455/59	2013/0107921	A1 *	5/2013	Prodan	.....	H04B 1/04	375/222
2004/0218568	A1 *	11/2004	Goodall	.....	H04L 1/0002	370/332	2013/0114480	A1 *	5/2013	Chapman	.....	H04L 5/1469	370/282
2005/0122996	A1 *	6/2005	Azenkot	.....	H04L 12/2801	370/477	2013/0266310	A1 *	10/2013	Fox	.....	H04L 25/08	398/25
2005/0135253	A1 *	6/2005	Cai	.....	H04L 1/0003	370/236	2014/0022926	A1 *	1/2014	Ling	.....	H04L 41/083	370/252
2005/0185824	A1 *	8/2005	Chen	.....	G06K 9/3241	382/103	2014/0133330	A1 *	5/2014	Chapman	.....	H04L 41/0806	370/252
2005/0213579	A1 *	9/2005	Iyer	.....	H04L 63/1441	370/395.2	2014/0169431	A1 *	6/2014	Arambepola	.....	H04L 27/0006	375/227
2006/0008020	A1 *	1/2006	Blankenship	.....	H04L 1/0003	375/261	2014/0286203	A1 *	9/2014	Jindal	.....	H04J 11/0026	370/278
2007/0202904	A1 *	8/2007	Cheng	.....	H04W 72/1231	455/509	2015/0071161	A1 *	3/2015	Salhab	.....	H04W 24/02	370/315
							2015/0288498	A1 *	10/2015	Kliger	.....	H04L 5/0048	370/491

\* cited by examiner

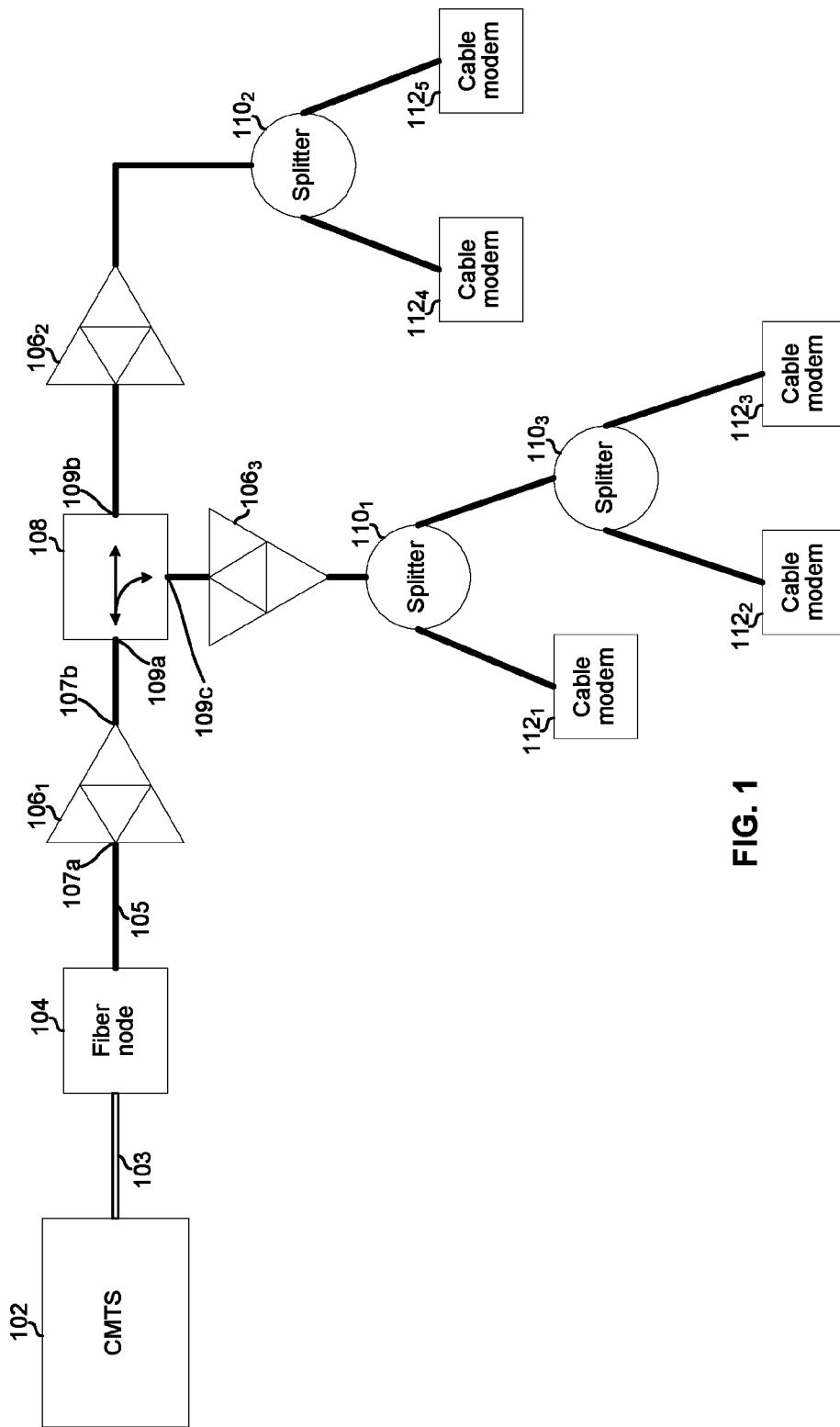

FIG. 1

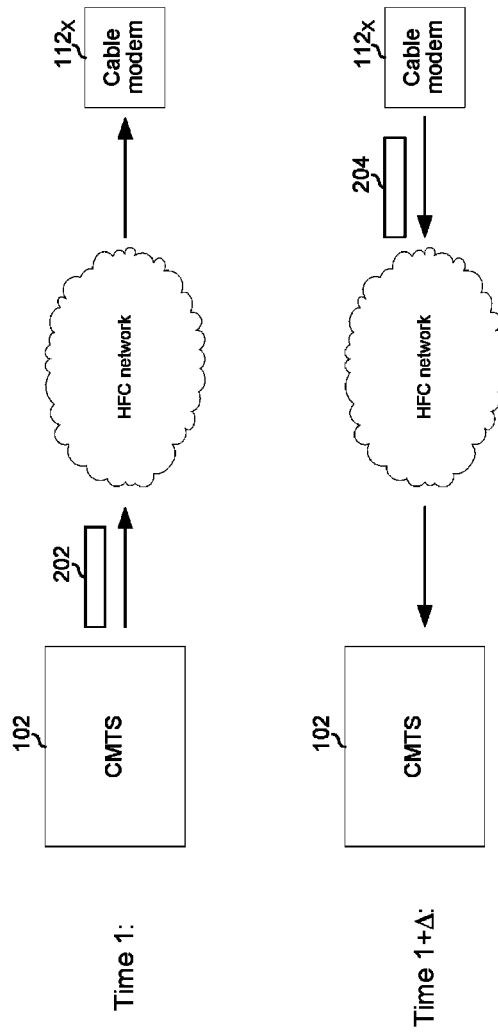

FIG. 2A

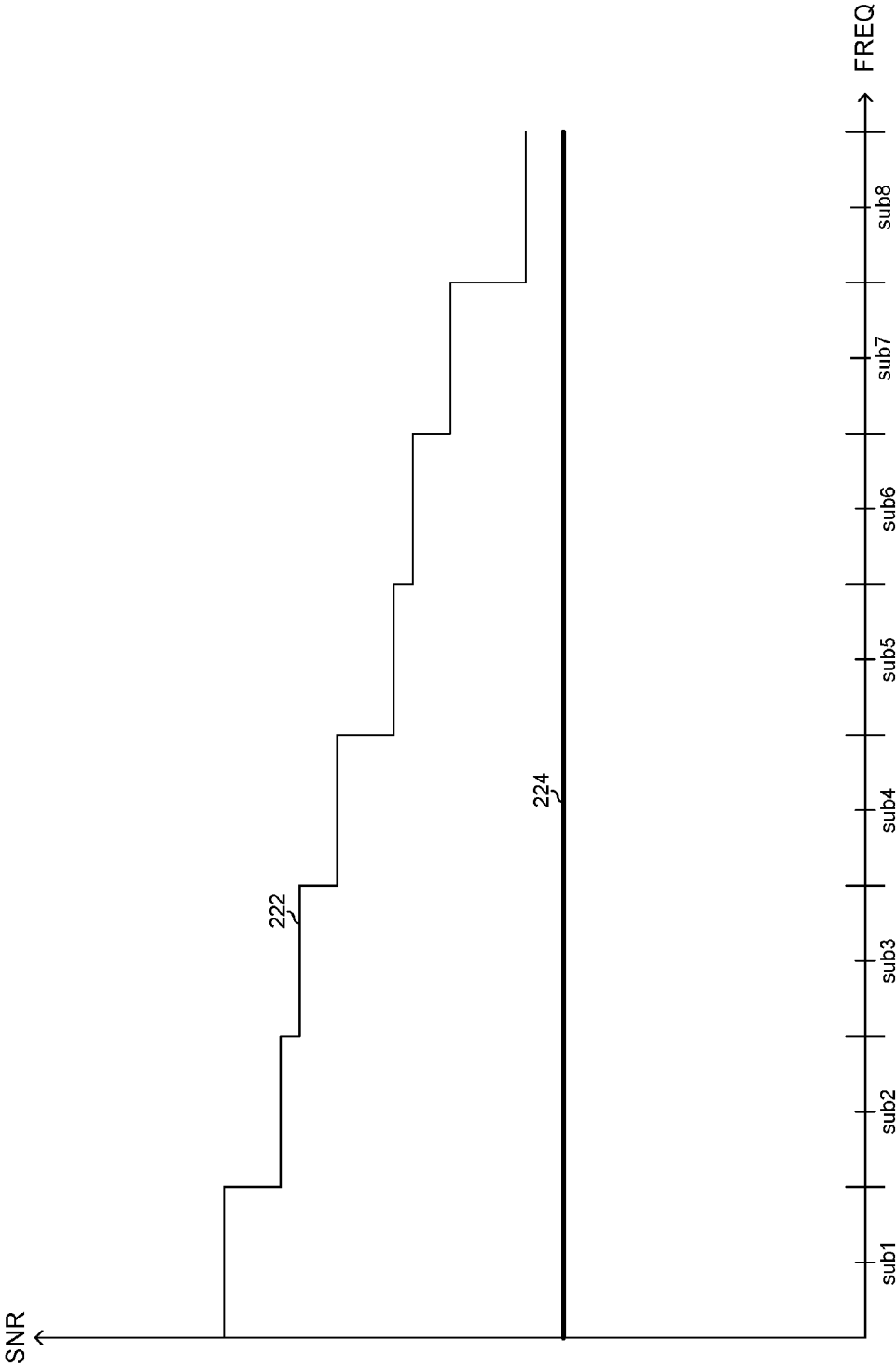

FIG. 2B

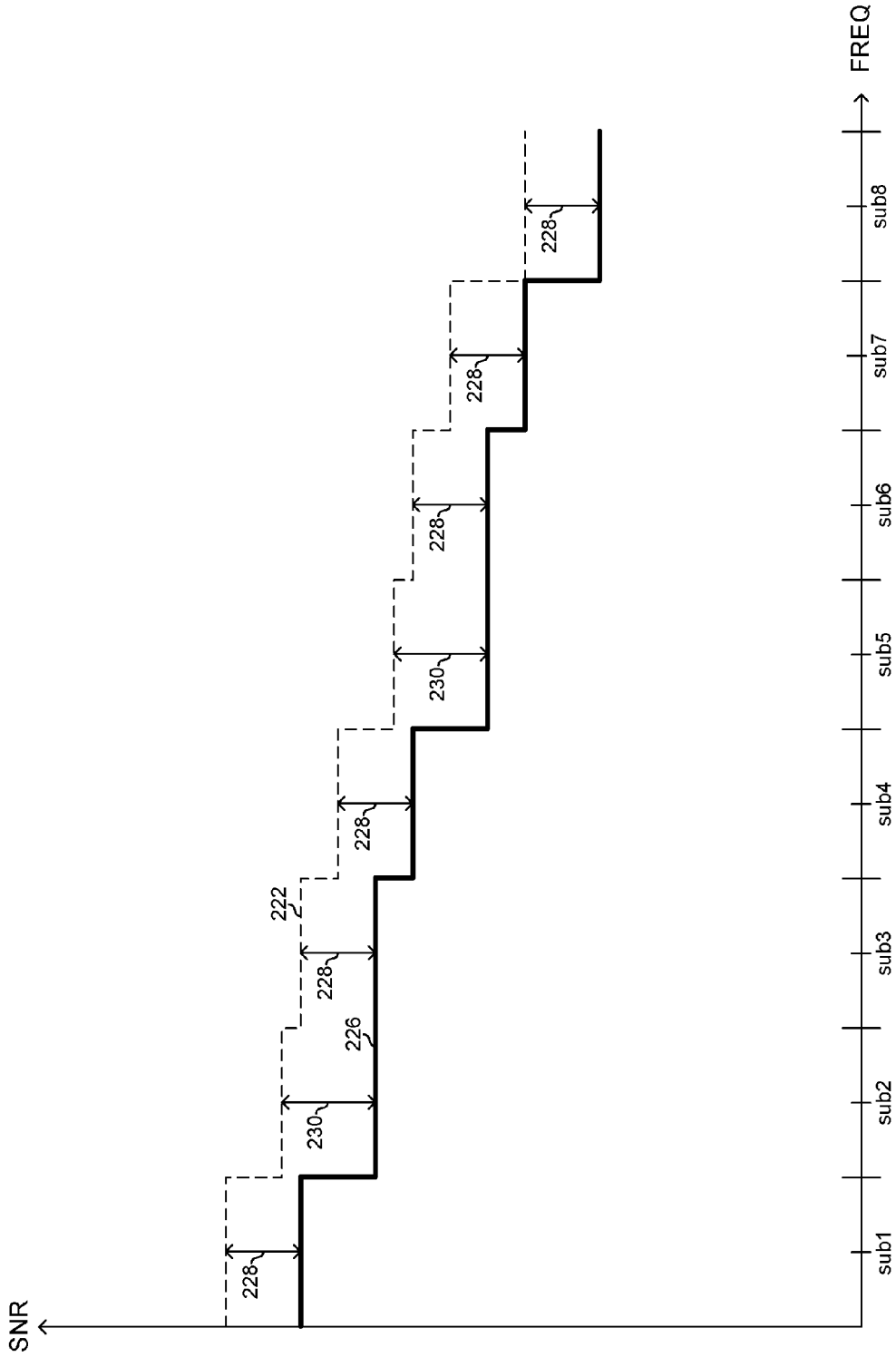

FIG. 2C

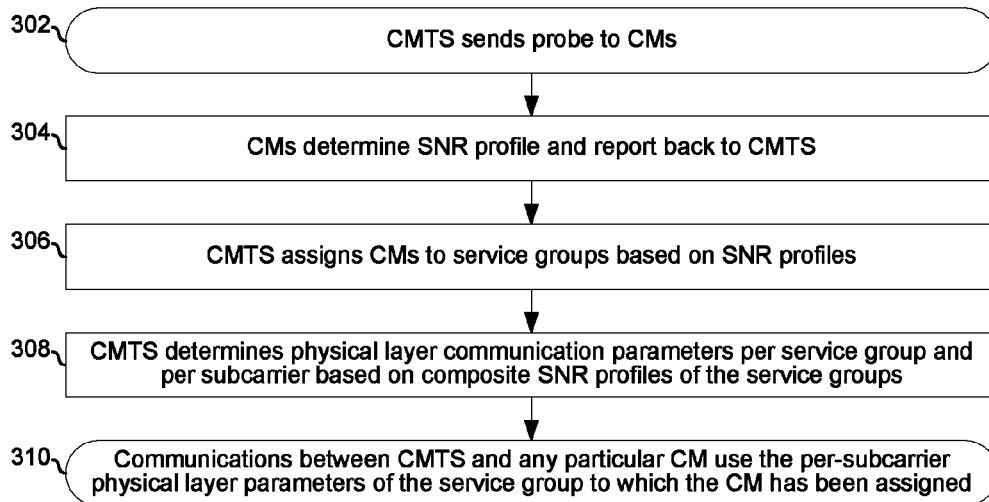

FIG. 3A

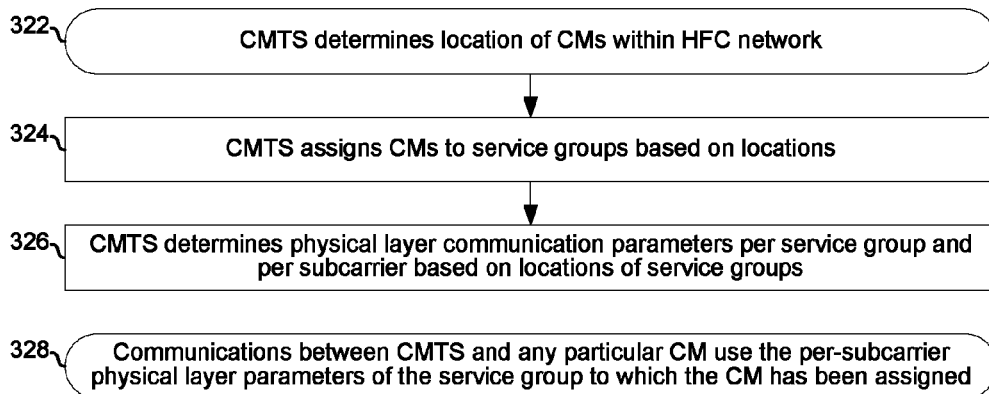

FIG. 3B

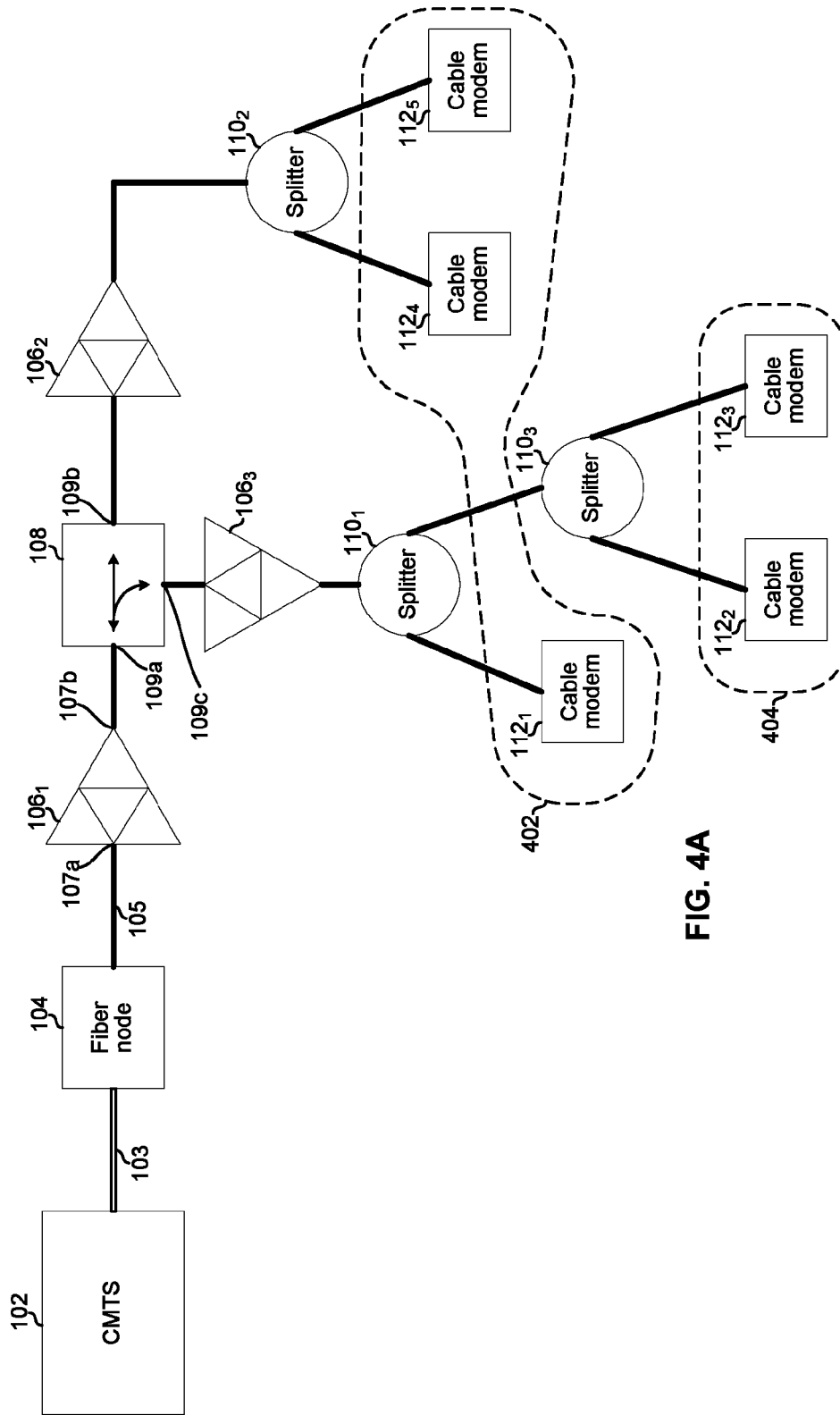

FIG. 4A



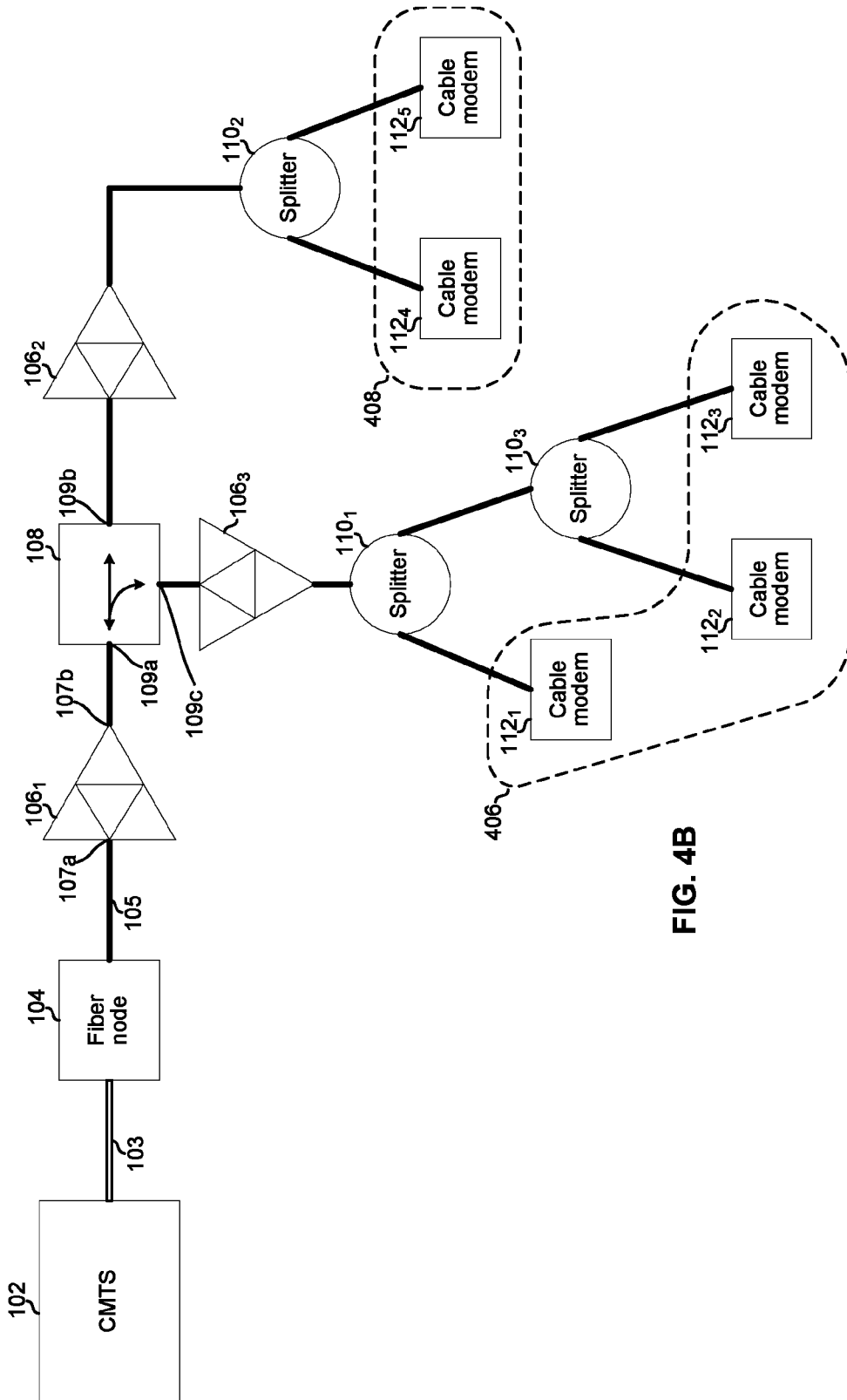

FIG. 4B

1

## METHOD AND SYSTEM FOR SERVICE GROUP MANAGEMENT IN A CABLE NETWORK

### PRIORITY CLAIM

This patent application is a continuation of U.S. patent application Ser. No. 13/948,444 filed on Jul. 23, 2013, which makes reference to, claims priority to and claims benefit from U.S. Provisional Patent Application Ser. No. 61/674,742 titled "Method and System for Service Group Management in a Cable Television Network" and filed on Jul. 23, 2012.

The entirety of each of the above-mentioned applications is hereby incorporated herein by reference.

### INCORPORATION BY REFERENCE

This application also makes reference to:

U.S. patent application Ser. No. 13/553,328 titled "Method and System for Client-Side Message Handling in a Low-Power Wide Area Network," and filed on Jul. 19, 2012;

U.S. patent application Ser. No. 13/485,034 titled "Method and System for Server-Side Message Handling in a Low-Power Wide Area Network," and filed on May 31, 2012;

U.S. patent application Ser. No. 13/553,175 titled "Method and System for a Low-Power Client in a Wide Area Network," and filed on Jul. 19, 2012;

U.S. patent application Ser. No. 13/553,195 titled "Method and System for Server-Side Handling of a Low-Power Client in a Wide Area Network," and filed on Jul. 19, 2012;

U.S. patent application Ser. No. 13/948,401 titled "Method and System for a High Capacity Cable Network," and filed on the same date as this application; and

U.S. patent application Ser. No. 13/948,417 titled "Method and System for Noise Suppression in a Cable Network," and filed on the same date as this application.

The entirety of each of the above-mentioned applications is hereby incorporated herein by reference.

### FIELD OF THE INVENTION

Certain embodiments of the invention relate to cable television networks. More specifically, certain embodiments of the invention relate to a method and system for service group management in a cable television network.

### BACKGROUND OF THE INVENTION

Convention cable television networks can be inefficient and have insufficient capacity. Further limitations and disadvantages of conventional and traditional approaches will become apparent to one of skill in the art, through comparison of such systems with some aspects of the present invention as set forth in the remainder of the present application with reference to the drawings.

### BRIEF SUMMARY OF THE INVENTION

A system and/or method is provided for service group management in a cable television network, substantially as shown in and/or described in connection with at least one of the figures, as set forth more completely in the claims.

These and other advantages, aspects and novel features of the present invention, as well as details of an illustrated

2

embodiment thereof, will be more fully understood from the following description and drawings.

### BRIEF DESCRIPTION OF SEVERAL VIEWS OF THE DRAWINGS

FIG. 1 is a diagram of an example cable/DOCSIS network.

FIG. 2A depicts an example method of determining locations of CMs within the HFC network.

FIGS. 2B and 2C depict signal-to-noise ratio (SNR) versus frequency profiles for an example cable/DOCSIS network.

FIG. 3A is a flowchart illustrating an example process for configuring a cable/DOCSIS HFC network based on measured performance metrics.

FIG. 3B is a flowchart illustrating an example process for configuring a cable/DOCSIS HFC network based on location of CMs within the network.

FIGS. 4A and 4B illustrate the network of FIG. 1, with different groupings of CMs based on one or both of: measured performance metric(s) and location within the HFC network.

### DETAILED DESCRIPTION OF THE INVENTION

As utilized herein the terms "circuits" and "circuitry" refer to physical electronic components (i.e. hardware) and any software and/or firmware ("code") which may configure the hardware, be executed by the hardware, and or otherwise be associated with the hardware. As used herein, for example, a particular processor and memory may comprise a first "circuit" when executing a first one or more lines of code and may comprise a second "circuit" when executing a second one or more lines of code. As utilized herein, "and/or" means any one or more of the items in the list joined by "and/or". As an example, "x and/or y" means any element of the three-element set  $\{(x), (y), (x, y)\}$ . As another example, "x, y, and/or z" means any element of the seven-element set  $\{(x), (y), (z), (x, y), (x, z), (y, z), (x, y, z)\}$ . As utilized herein, the term "exemplary" means serving as a non-limiting example, instance, or illustration. As utilized herein, the terms "e.g.," and "for example" set off lists of one or more non-limiting examples, instances, or illustrations. As utilized herein, circuitry is "operable" to perform a function whenever the circuitry comprises the necessary hardware and code (if any is necessary) to perform the function, regardless of whether performance of the function is disabled, or not enabled, by some user-configurable setting.

FIG. 1 is a diagram of an example cable/DOCSIS network. The example network comprises a cable modem termination system (CMTS) 102, a fiber node 104, amplifiers 106<sub>1</sub>-106<sub>3</sub>, a directional coupler 108, splitters 110<sub>1</sub>-110<sub>3</sub>, and cable modems (CMs) 112<sub>1</sub>-112<sub>5</sub>.

The CMTS 102 may comprise circuitry operable to manage connections to the CMs 112<sub>1</sub>-112<sub>5</sub>. This may include, for example: participating in ranging operations to determine physical layer parameters used for communications between the CMTS 102 and CMs 112<sub>1</sub>-112<sub>5</sub>; forwarding of dynamic host configuration protocol (DHCP) messages between a DHCP server and the CMs 112<sub>1</sub>-112<sub>5</sub>; forwarding of time of day messages between a time of day server and the CMs 112<sub>1</sub>-112<sub>5</sub>; directing traffic between the CMs 112<sub>1</sub>-112<sub>5</sub> other network devices (e.g., Ethernet interfaces of the CMTS 102 may face the Internet, Optical RF interfaces of the

CMTS **102** may face the CMs, and the CMTS may direct traffic between and among the Ethernet and Optical RF interfaces); and managing registration of the CMs **112<sub>1</sub>-112<sub>5</sub>** to grant the cable modems network (e.g., Internet) access. The registration process for a CM **112<sub>X</sub>** (X between 1 and 5 for the example network of FIG. 1) may comprise the CM **112** sending a registration request along with its configuration settings, and the CMTS **102** accepting or rejecting the cable modem based on the configuration settings. The registration process may additionally comprise an exchange of security keys, certificates, or other authentication information.

The fiber node **104** may comprise circuitry operable to convert between optical signals conveyed via the fiber optic cable **103** and electrical signals conveyed via coaxial cable **105**.

Each of the amplifiers **106<sub>1</sub>-106<sub>3</sub>** may comprise a bidirectional amplifier which may amplify downstream signals and upstream signals, where downstream signals are input via upstream interface **107a** and output via downstream interface **107b**, and upstream signals are input via downstream interface **107b** and output via upstream interface **107a**. The amplifiers **106<sub>1</sub>**, which amplifies signals along the main coaxial “trunk” may be referred to as a “trunk amplifier.” The amplifiers **106<sub>2</sub>** and **106<sub>3</sub>** which amplify signals along “branches” split off from the trunk may be referred to as “branch” or “distribution” amplifiers.

The directional coupler **108** may comprise circuitry operable to direct downstream traffic incident on interface **109a** onto interfaces **109b** and **109c**, and to direct upstream traffic incident on interfaces **109b** and **109c** onto interface **109a**. The directional coupler **108** may be a passive device.

Each of the splitters **110<sub>1</sub>-110<sub>3</sub>** may comprise circuitry operable to output signals incident on each of its interfaces onto each of its other interfaces. Each of the splitters **110<sub>1</sub>-110<sub>3</sub>** may be a passive device.

Each of the cable modems (CMs) **112<sub>1</sub>-112<sub>5</sub>** may comprise circuitry operable to communicate with, and be managed by, the CMTS **102** in accordance with one or more standards (e.g., DOCSIS). Each of the CMs **112<sub>1</sub>-112<sub>5</sub>** may reside at the premises of a cable subscriber.

The components (including, fiber optic cables, coaxial cables, amplifiers, directional couplers, splitters, and/or other devices) between the CMTS and the CMs may be referred to as a hybrid fiber coaxial (HFC) network. Any of the amplifiers, directional coupler, and splitters may be referred to generically as a coupling device.

FIG. 2A depicts an example method of determining locations of CMs within the HFC network. As shown in FIG. 2A, to determine one or more measured performance metric (s) (e.g., an SNR-related metric such as SNR at a particular frequency or SNR over a range of frequencies (an SNR profile), noise levels, strength of desired signals, and/or the like) for any particular CM **112<sub>X</sub>**, the CMTS **102** may transmit, at time **1**, a message **202** that is destined (unicast, multicast, or broadcast) for the CM **112<sub>X</sub>** and that functions as a probe to enable determination of the metric(s) for the CM **112<sub>X</sub>**. The message **202** may be sent on multiple channels spanning multiple frequencies. Similarly, where OFDM is used for communications between the CMTS **102** and the CM **112<sub>X</sub>**, the message **202** may be transmitted on each subcarrier, or may be sent on a subset of subcarriers and then interpolation may be used for determining the SNR of subcarriers on which the message **202** was not sent.

The message **202** may be transmitted with such encoding, modulation, and transmit power such that even a CM **112<sub>X</sub>** with a worst-case performance metric(s) can receive the

message and accurately measure the metric(s). In this regard, FIG. 2B shows a SNR versus frequency graph for an example HFC network that uses eight channels/subcarriers. The line **222** in FIG. 2B represents a composite worst-case SNR profile for one or more CM(s) in the HFC network to which the message **202** is destined. For example, line **222** may be a SNR profile for a single CM **112<sub>X</sub>** to which the message **202** is to be unicast. As another example, the line **222** may be a composite worst-case SNR profile for a plurality of CMs **112** of a particular service group to which the message **202** is to be multicast. As another example, the line **222** may be a composite worst-case SNR profile for all CMs of an HFC network handled by the CMTS **102** to which the message **202** is to be broadcast. The message **202** may be transmitted such that the minimum SNR needed to receive and accurately measure the SNR profile is below the line **222** (e.g., SNR needed for receiving the message **202** may be the line **224**).

Upon receipt of the message **202**, a CM **112<sub>X</sub>** may measure, over the channels/subbands on which the message was sent, one or more metrics (e.g., SNR versus frequency profile) for the transmission **202**. The CM **112<sub>X</sub>** may then report the metrics(s) back to the CMTS **102** via a message **204**. In an example implementation, the message **202** may contain information about when and/or how the CM(s) are supposed to report their metric(s) (e.g., SNR profiles) back to the CMTS **102**. In this regard, the message **202** may contain information that is the same as and/or analogous to what may be found in a MAP, UCD, and/or other MAC management message defined in a DOCSIS standard. Accordingly, the message **202** may have specified a format of the message **204** and that the message **204** is to be transmitted at time T+Δ.

Once the metric(s) of one or more CMs are known to the CMTS **102**, physical layer communication parameters to be used for communications between the CMTS **102** and the CMs **112** may be determined based on the metric(s). In this regard, physical layer communication parameters may be determined per-CM based on each CM's respective metric (s) (e.g., each CM's SNR profile), per-service-group based on a composite metric(s) of the CM(s) assigned to that service group (e.g., composite SNR profile for the CM(s) of that service group), per physical region of the HFC network based on a composite metric of the CMs located in that physical region (e.g., composite SNR profile for the CM(s) in that physical region), and/or the like. Furthermore, once the metric(s) of a CM **112<sub>X</sub>** is determined, the CMTS **102** may assign that CM **112<sub>X</sub>** to one or more service groups based on its metric(s), as, for example, described below with reference to FIG. 4A. Example physical layer parameters include: encoding parameters, modulation parameters, transmit power, receive sensitivity, timeslot duration, channel(s) or subcarrier(s) on which to listen, channel(s) or subcarrier (s) on which to transmit, and/or the like. Example encoding parameters include: type of forward error correction (FEC) to be used (e.g., Reed-Solomon, LDPC, etc.), FEC block size, FEC code rate, etc. Example modulation parameters include: type of modulation (e.g., frequency shift keying (FSK), phase shift keying (PSK), quadrature amplitude modulation (QAM), etc.), modulation depth, modulation order, etc.

In an example implementation, the transmission of messages **202**, the calculation of metrics, such as SNR profile, by the CM(s), the transmission **204**, and subsequent configuration of physical layer parameters based on the metric (s) may take place in parallel with other operations performed during the registration/ranging process.

5

Referring now to FIG. 2C, there is again shown the line 222 which represents the applicable SNR profile (e.g., an individual SNR profile if configuring physical layer parameters per CM, a composite SNR profile for a service group if configuring physical layer parameters per service group, or a composite SNR profile for a particular physical region). Also shown is a line 226 corresponding to SNR utilization for communications with the CM(s) associated with the profile 222. Assuming the distance 228 is the minimum desired headroom, then the physical layer communication parameters resulting in line 226 are nearly optimal in the sense that there is minimal headroom on each of channels/subbands 1, 3, 4, 6, 7, 8, and only slightly more than minimal headroom on channels/subbands 2 and 5.

Physical layer parameters may be configured/coordinated using upstream and/or downstream MAP messages, upstream channel descriptors (UCDs), other MAC management messages defined in DOCSIS protocols, and/or purpose-specific messages tailored to configuring the parameters based on measured performance metrics such as SNR profiles as described in this disclosure.

FIG. 3A is a flowchart illustrating an example process for configuring a cable/DOCSIS HFC network based on SNR profiles. For clarity of illustration the process is described with reference to the network of FIG. 1 and the messages of FIG. 2A. The process begins with block 302 in which the CMTS 102 sends one or more probe messages 202 to the CMs 112<sub>1</sub>-112<sub>5</sub>. In block 304, each of the CMs 112<sub>1</sub>-112<sub>5</sub> determines its respective SNR profile based on a received one of the messages 202, and reports the SNR profile back to the CMTS 102 in the form of a message 204. In block 306, the CMTS 102 assigns the CMs to service groups based on the SNR profiles.

In block 308, physical layer communication parameters are determined per service group and per channel/subcarrier. For example, for any particular service group, the modulation order and FEC code rate to be used on a particular subcarrier may be determined based on the worst case SNR for that subcarrier among the CMs in that particular service group. Thus, it can be seen that grouping CMs based on SNR profiles may enable configuring physical layer communication parameters to such that one or more communication parameters (throughput, reliability, etc.) is optimal, or near-optimal, for all of the CMs in the service group. For example, without such grouping by SNR profile, one CM in a particular service group may have substantially lower SNR on one or more channels/subcarriers. As a result, all CMs in that particular service group may be forced to use physical layer parameters supported by this "lowest common denominator" CM. This may result in a lot of wasted capacity for the remaining CMs.

To illustrate with a specific example: assume that CMs 112<sub>1</sub>, 112<sub>4</sub>, and 112<sub>5</sub> of FIG. 1 have sufficient SNR on channel z to support 64-QAM on channel z, but that CMs 112<sub>2</sub> and 112<sub>3</sub> only have sufficient SNR on channel z to support 16-QAM. If 112<sub>1</sub> is assigned to the same service group as 112<sub>2</sub> or 112<sub>3</sub>, then 112<sub>1</sub> may be forced to use 16-QAM on channel z. Conversely, if 112<sub>1</sub>, 112<sub>4</sub>, and 112<sub>5</sub> are assigned to a first service group and 112<sub>2</sub> and 112<sub>3</sub> are assigned to a second service group, then the first service group consisting of 112<sub>1</sub>, 112<sub>4</sub>, and 112<sub>5</sub> can use 64-QAM on channel z while the second service group consisting of 112<sub>2</sub> and 112<sub>3</sub> uses 16-QAM on channel z.

In block 310, communications between the CMTS 102 and any particular service group use the per-service-group and per-subcarrier/channel physical layer parameters determined in block 308.

6

FIG. 3B is a flowchart illustrating an example process for configuring a cable/DOCSIS HFC network based on location of CMs within the network. For clarity of illustration, and as a non-limiting example, the process is described with reference to the network of FIG. 1 and the messages of FIG. 2B. The process begins with block 322 in which the CMTS 102 determines a location of each of the CMs 112<sub>1</sub>-112<sub>5</sub> in the network. Location of a CM 112<sub>x</sub> may be characterized in a variety of ways including, for example: total distance of fiber and/or coaxial cable between the CMTS 102 and the CM 112<sub>x</sub>, total attenuation between the CMTS 102 and the CM 112<sub>x</sub>, which trunk amplifier(s) are upstream of the CM 112<sub>x</sub>, how many coupling elements (amplifiers, splitters, directional couplers, etc.) are between the CMTS 102 and the CM 112<sub>x</sub>, GPS coordinates, and street address. In block 324, the CMTS 102 assigns the CMs 112<sub>1</sub>-112<sub>5</sub> to service groups based on their determined locations. Blocks 326 and 328 are substantially similar to blocks 308 and 310, respectively, of FIG. 3A.

The locations of the CMs 112<sub>1</sub>-112<sub>5</sub> may be determined by, for example, transmitting sounding signals into the network. In order to characterize the channel with more precision, the channel sounding signal may be sent repeatedly over an interval of time and the CMs may average multiple measurements over the time interval until they can resolve identifying characteristics in the signal which indicate, for example, how many branch amplifiers and/or other coupling elements that the signal traveled through to reach the CM. In another example implementation, the CMTS may communicate with a server that stores subscriber information that associates the CMs with their geographic location (e.g., street address).

While FIGS. 3A and 3B depict SNR profiles and location as two separate bases on which to assign CMs to service groups, the two may be used in combination.

FIGS. 4A and 4B illustrate the network of FIG. 1, with different groupings of CMs based on one or both of: measured performance metric(s) and location within the HFC network.

In the example of FIG. 4A, CMs 112<sub>1</sub>, 112<sub>4</sub>, and 112<sub>5</sub> are assigned to service group 402 and CMs 112<sub>2</sub> and 112<sub>3</sub> are assigned to service group 404. The assignment of FIG. 4A may result from, for example, assigning CMs based on the number of coupling elements between the CMTS 102 and the CMs—four each for CMs 112<sub>1</sub>, 112<sub>4</sub>, and 112<sub>5</sub>; five each for CMs 112<sub>2</sub> and 112<sub>3</sub>. The number of coupling elements may be determined based on, for example, measured performance metrics (e.g., SNR profile) of the CMs and/or address or GPS information associated with the CMs. Alternatively, the assignment of FIG. 3A may result from, for example, assigning the CMs to service groups based directly on their respective measured performance metric(s) (e.g., the extra device in the path between CMTS 102 and CMs 112<sub>2</sub> and 112<sub>3</sub> may cause CMs 112<sub>2</sub> and 112<sub>3</sub> to have significantly poorer SNR).

In the example of FIG. 4B, CMs 112<sub>1</sub>, 112<sub>2</sub>, and 112<sub>3</sub> are assigned to service group 406 and CMs 112<sub>4</sub> and 112<sub>5</sub> are assigned to service group 408. The assignment of FIG. 4B may result from, for example, assigning CMs based on which trunk amplifiers are downstream of the CMs. Alternatively, the assignment of FIG. 3A may result from, for example, assigning the CMs to service groups based directly on their respective measured performance metric(s) (e.g., the distance between CMTS 102 and CMs 112<sub>4</sub> and 112<sub>5</sub> may be substantially greater than the distance between the CMTS 102 and the CMs 112<sub>1</sub>, 112<sub>2</sub>, and 112<sub>3</sub>, thus resulting in poorer SNR in CMs 112<sub>4</sub> and 112<sub>5</sub>).

Grouping CMs according to which trunk or distribution amplifiers are upstream of them may enable duty cycling power branch and/or distribution amplifiers. For example, when a CM in service group 406 is the talker, the upstream path through amplifier 1062 may be disabled such that noise from group 408 does not interfere with transmissions from the talker of service group 406. Grouping CMs according to which trunk or distribution amplifier(s) serve(s) them may enable using more efficient physical layer parameters. For example, where there is a relatively long distance of cable between amplifier 106<sub>1</sub> and 106<sub>2</sub> but relatively short distance of cable between amplifiers 106<sub>1</sub> and 106<sub>3</sub>, grouping the CMs by geography/distance to the CMTS may enable a lower transmit power to be used by the CMTS 102 when talking to service group 406 as compared to when talking to service group 408.

Other embodiments of the invention may provide a non-transitory computer readable medium and/or storage medium, and/or a non-transitory machine readable medium and/or storage medium, having stored thereon, a machine code and/or a computer program having at least one code section executable by a machine and/or a computer, thereby causing the machine and/or computer to perform processes described.

Accordingly, the present invention may be realized in hardware, software, or a combination of hardware and software. The present invention may be realized in a centralized fashion in at least one computing system, or in a distributed fashion where different elements are spread across several interconnected computing systems. Any kind of computing system or other apparatus adapted for carrying out the methods described herein is suited. A typical combination of hardware and software may be a general-purpose computing system with a program or other code that, when being loaded and executed, controls the computing system such that it carries out the methods described herein. Another typical implementation may comprise an application specific integrated circuit or chip.

The present invention may also be embedded in a computer program product, which comprises all the features enabling the implementation of the methods described herein, and which when loaded in a computer system is able to carry out these methods. Computer program in the present context means any expression, in any language, code or notation, of a set of instructions intended to cause a system having an information processing capability to perform a particular function either directly or after either or both of the following: a) conversion to another language, code or notation; b) reproduction in a different material form.

While the present invention has been described with reference to certain embodiments, it will be understood by those skilled in the art that various changes may be made and equivalents may be substituted without departing from the scope of the present invention. In addition, many modifications may be made to adapt a particular situation or material to the teachings of the present invention without departing from its scope. Therefore, it is intended that the present invention not be limited to the particular embodiment disclosed, but that the present invention will include all embodiments falling within the scope of the appended claims.

What is claimed is:

1. A method comprising:  
determining, by a cable modem termination system (CMTS), for a plurality of cable modems served by said

CMTS, a corresponding plurality of signal-to-noise ratio (SNR) related metrics comprising SNR versus frequency profiles;

assigning, by said CMTS, said plurality of cable modems among a plurality of service groups based on said plurality of SNR-related metrics;

generating, by said CMTS for each one of said plurality of service groups, a composite SNR-related metric based on a portion of said plurality of SNR-related metrics corresponding to said one of said plurality of service groups;

selecting, by said CMTS, physical layer communication parameters to be used for communicating with said one of said plurality of service groups based on said composite SNR-related metric; and

communicating, by said CMTS, with a portion of said plurality of cable modems corresponding to said one of said plurality of service groups using said selected physical layer communication parameters,

wherein said composite SNR related metric is a worst-case SNR versus frequency profile for said one of said plurality of service groups.

2. The method of claim 1, wherein said physical layer communication parameters include one or more of: transmit power, receive sensitivity, timeslot duration, modulation type, modulation order, forward error correction (FEC) type, and FEC code rate.

3. The method of claim 1, wherein said CMTS uses orthogonal frequency division multiplexing (OFDM) over a plurality of subcarriers for said communicating.

4. The method of claim 3, comprising selecting, by said CMTS, said physical layer communication parameters on a per-OFDM-subcarrier basis.

5. The method of claim 4, wherein said physical layer communication parameters include one or both of: which of said OFDM subcarriers to use for transmission to said CMTS, and which of said OFDM subcarriers to use for reception of information from said CMTS.

6. The method of claim 1, wherein:

said plurality of service groups comprises a first service group and a second service group;

said first service group has a first composite SNR versus frequency profile, said second service group has a second composite SNR versus frequency profile, and a third cable modem has a particular SNR versus frequency profile; and

said assigning said plurality of cable modems among said plurality of service groups comprises:

assigning said third cable modem to said first service group if said particular SNR versus frequency profile is more similar to said first composite SNR versus frequency profile than to said second composite SNR versus frequency profile; and

assigning said third cable modem to said second service group if said particular SNR versus frequency profile is more similar to said second composite SNR versus frequency profile than to said first composite SNR versus frequency profile.

7. The method of claim 1, comprising assigning said plurality of cable modems among said plurality of service groups based on distances between said CMTS and said plurality of cable modems.

8. The method of claim 1, comprising assigning any particular one of said plurality of cable modems to one of said plurality of service groups based on which one or more of a plurality of branch amplifiers are upstream of said one of said plurality of cable modems.

9

9. The method of claim 1, wherein said determining said plurality of SNR-related metrics comprises:

transmitting a probe message to each said plurality of cable modems, said probe message comprising instructions for measuring a metric and reporting said measured metric back to said CMTS; and

receiving a metric reporting message from each of said plurality of cable modems.

10. A system comprising:

circuitry for use in a cable modem termination system (CMTS), said circuitry comprising a network interface and a processor wherein:

said processor is configured to determine, for a plurality of cable modems served by said CMTS, a corresponding plurality of signal-to-noise ratio (SNR) related metrics comprising SNR versus frequency profiles;

said processor is configured to assign said plurality of cable modems among a plurality of service groups based on said plurality of SNR-related metrics;

said processor is configured to generate, for each one of said plurality of service groups, a composite SNR-related metric based on a portion of said plurality of SNR-related metrics corresponding to said one of said plurality of service groups;

said processor is configured to select physical layer communication parameters to be used for communicating with said one of said plurality of service groups based on said composite SNR-related metric; and

said network interface is configured to communicate with a portion of said plurality of cable modems corresponding to said one of said plurality of service groups using the selected physical layer communication parameters, wherein said composite SNR related metric is a worst-case SNR versus frequency profile for said one of said plurality of service groups.

11. The system of claim 10, wherein said physical layer communication parameters include one or more of: transmit power, receive sensitivity, timeslot duration, modulation type, modulation order, forward error correction (FEC) type, and FEC code rate.

12. The system of claim 10, wherein said network interface and said plurality of cable modems are configured to communicate using orthogonal frequency division multiplexing (OFDM) over a plurality of subcarriers.

13. The system of claim 12, wherein said network interface is configured such that said physical layer communication parameters are configurable on a per-OFDM-subcarrier basis.

10

14. The system of claim 12, wherein said physical layer communication parameters include one or both of: which of said OFDM subcarriers to use for transmission to said CMTS, and which of said OFDM subcarriers to use for reception of information from said CMTS.

15. The system of claim 10, wherein:

said plurality of service groups comprises a first service group and a second service group;

said first service group has a first composite SNR versus frequency profile, said second service group has a second composite SNR versus frequency profile, and a third cable modem has a particular SNR versus frequency profile;

said assignment of said plurality of cable modems among said plurality of service groups comprises:

assignment of said third cable modem to said first service group if said particular SNR versus frequency profile is more similar to said first composite SNR versus frequency profile than to said second composite SNR versus frequency profile; and

assignment of said third cable modem to said second service group if said particular SNR versus frequency profile is more similar to said second composite SNR versus frequency profile than to said first composite SNR versus frequency profile.

16. The system of claim 10, wherein said processor is configured to assign said plurality of cable modems among said plurality of service groups based on distances between said CMTS and said plurality of cable modems.

17. The system of claim 10, wherein said processor is configured to assign said plurality of cable modems among said plurality of service groups based on a branch further branch amplifier that serves each of said plurality of cable modems.

18. The system of claim 10, wherein said determination of said plurality of SNR-related metrics comprises:

transmission, via said network interface, of a probe message to each said plurality of cable modems, said probe message comprising instructions for measuring a metric and reporting said measured metric back to said CMTS; and

reception, via said network interface of said CMTS, of a metric reporting message from each of said plurality of cable modems.

\* \* \* \* \*