



US 20170095345A1

(19) **United States**

(12) **Patent Application Publication**
Davenport et al.

(10) **Pub. No.: US 2017/0095345 A1**

(43) **Pub. Date: Apr. 6, 2017**

(54) **EXPANDABLE INTERVERTEBRAL IMPLANT**

Publication Classification

(71) Applicant: **GLOBUS MEDICAL, INC.,**
AUDUBON, PA (US)

(51) **Int. Cl.**
A61F 2/44 (2006.01)

(72) Inventors: **Daniel Davenport,** Collegeville, PA (US); **Chad Glerum,** Pennsburg, PA (US); **Duncan Sibson,** Malvern, PA (US)

(52) **U.S. Cl.**
CPC *A61F 2/447* (2013.01); *A61F 2/442* (2013.01); *A61F 2/4684* (2013.01)

(21) Appl. No.: **15/291,108**

(57) **ABSTRACT**

(22) Filed: **Oct. 12, 2016**

An implant for therapeutically separating bones of a joint has two endplates each having an opening through the endplate, and at least one ramped surface on a side opposite a bone engaging side. A frame is slideably connected to the endplates to enable the endplates to move relative to each other at an angle with respect to the longitudinal axis of the implant, in sliding connection with the frame. An actuator screw is rotatably connected to the frame. A carriage forms an open area aligned with the openings in the endplates. The openings in the endplates pass through the carriage to form an unimpeded passage from bone to bone of the joint. The carriage has ramps which mate with the ramped surfaces of the endplates, wherein when the carriage is moved by rotation of the actuator screw, the endplates move closer or farther apart.

Related U.S. Application Data

(63) Continuation of application No. 14/676,323, filed on Apr. 1, 2015, now Pat. No. 9,486,325, which is a continuation of application No. 13/836,005, filed on Mar. 15, 2013, now Pat. No. 9,149,367.

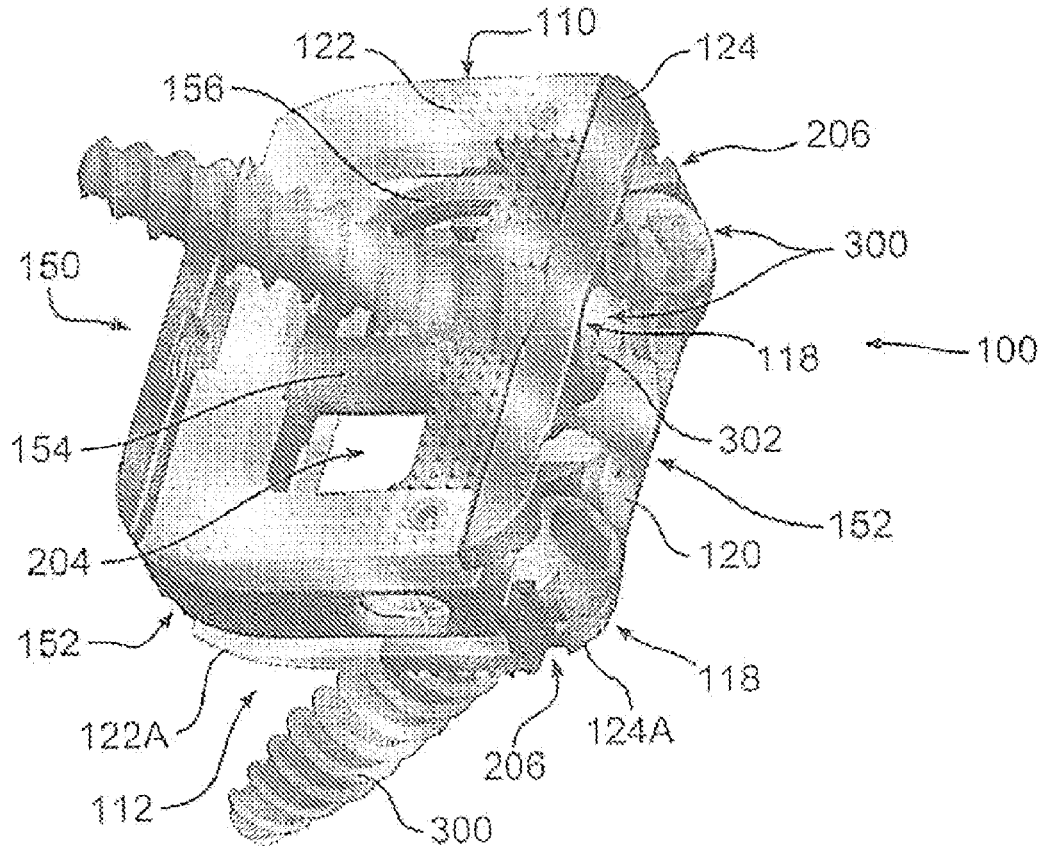

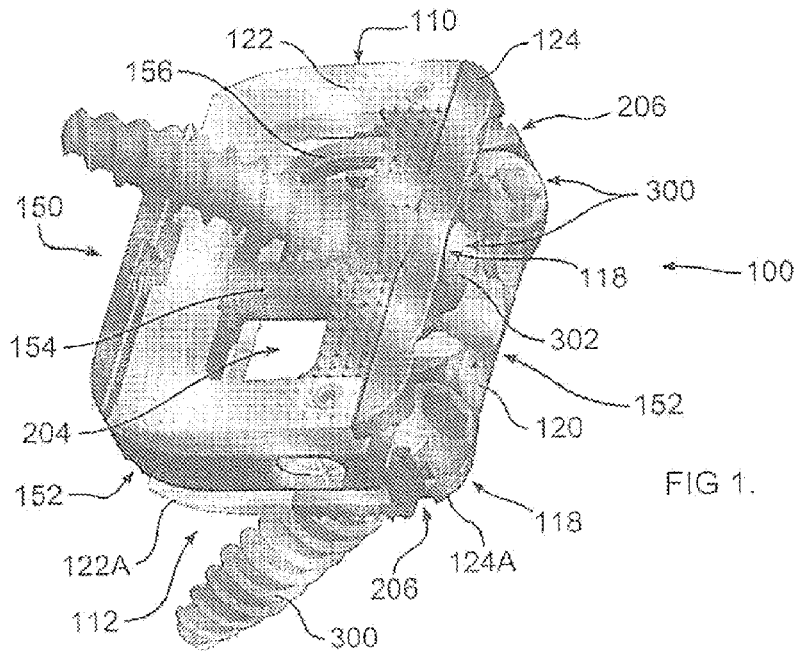

FIG 1.

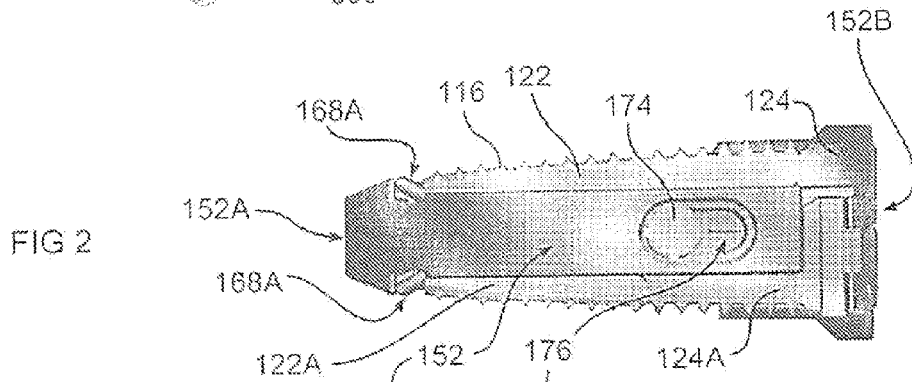

FIG 2

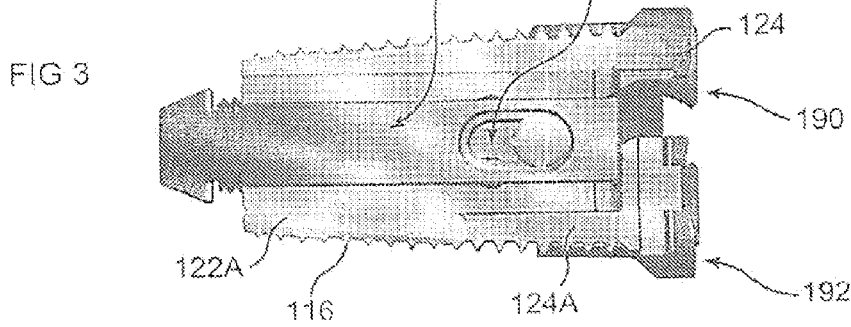
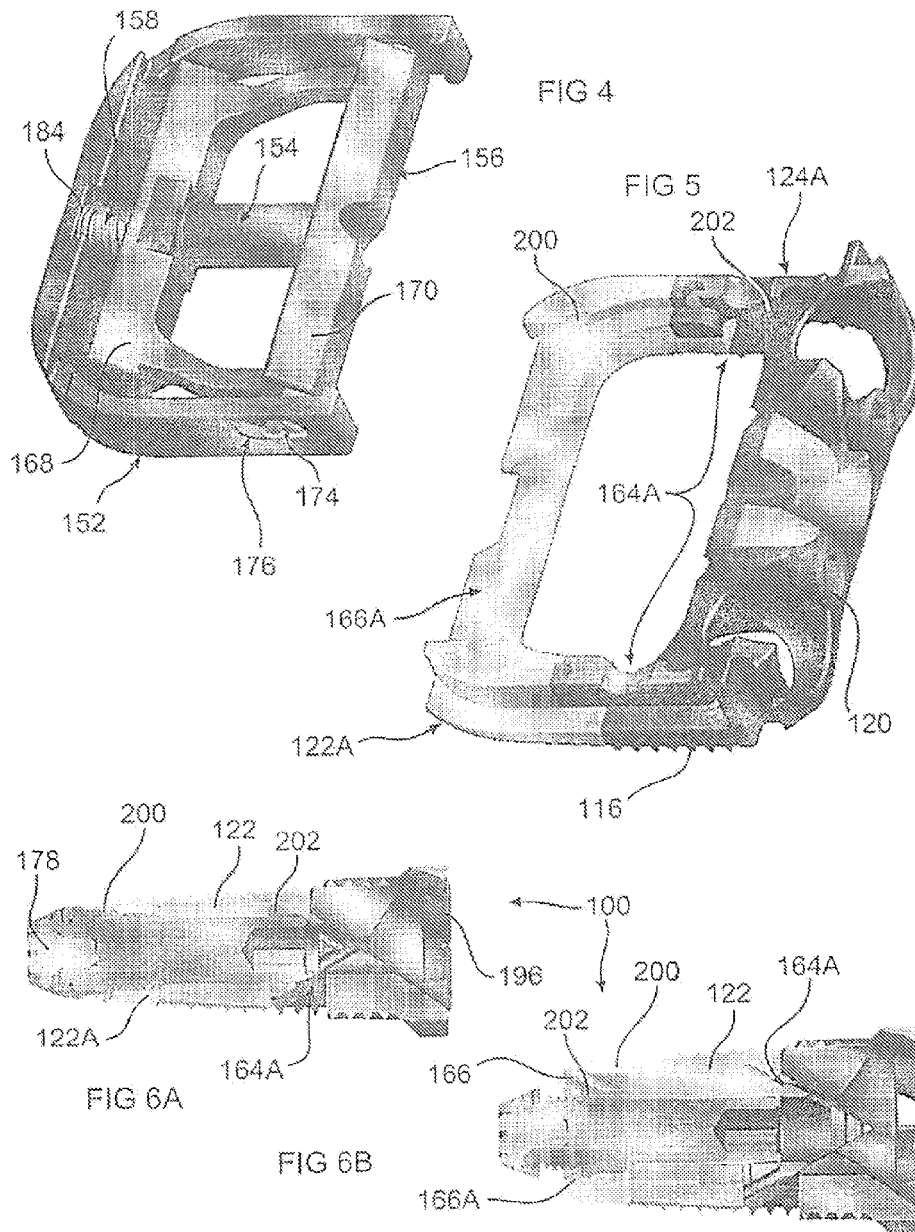
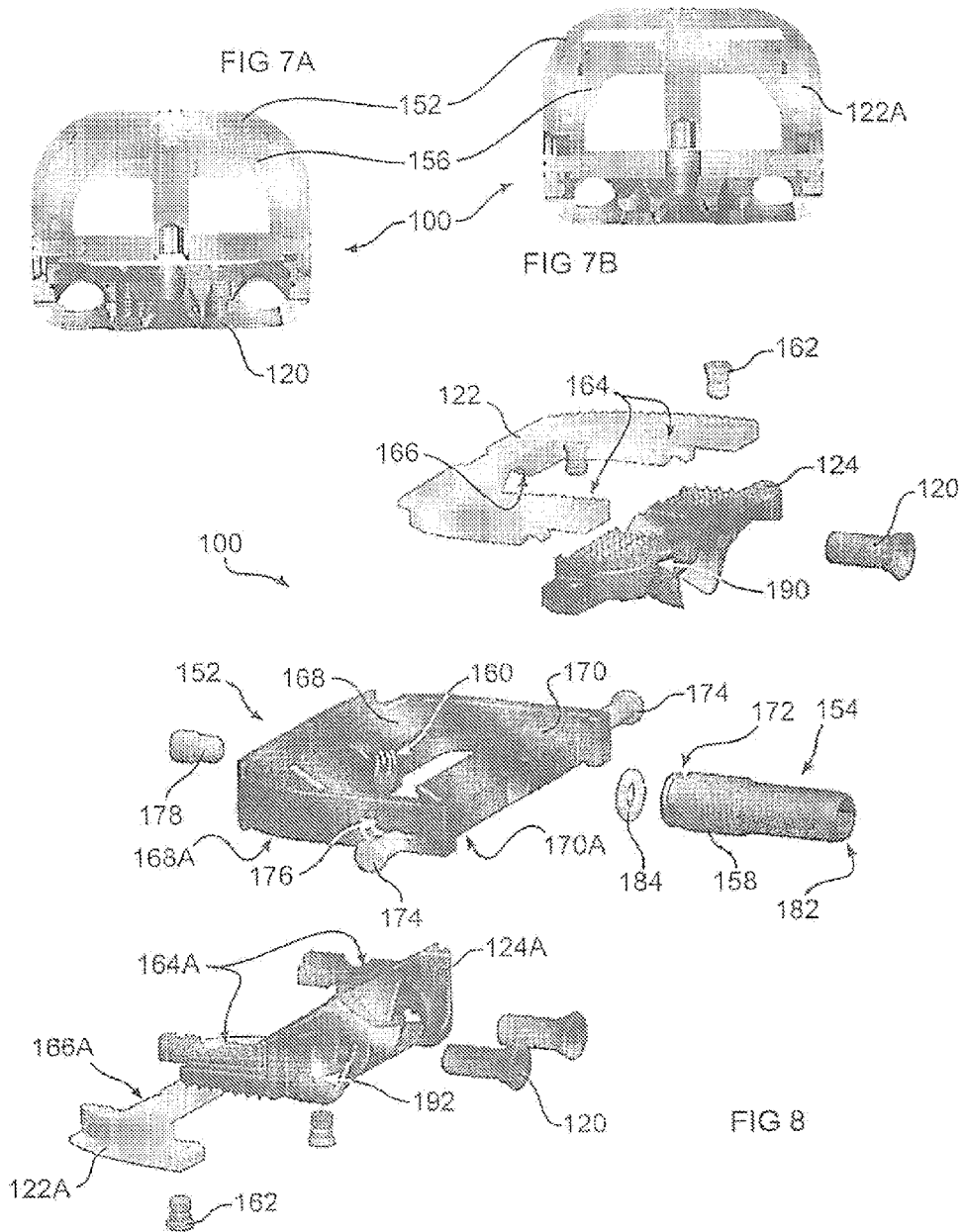
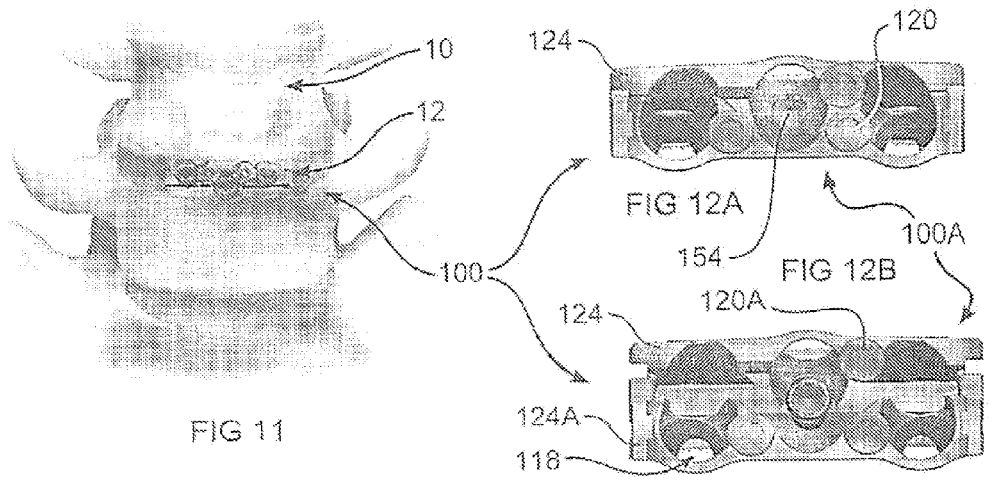
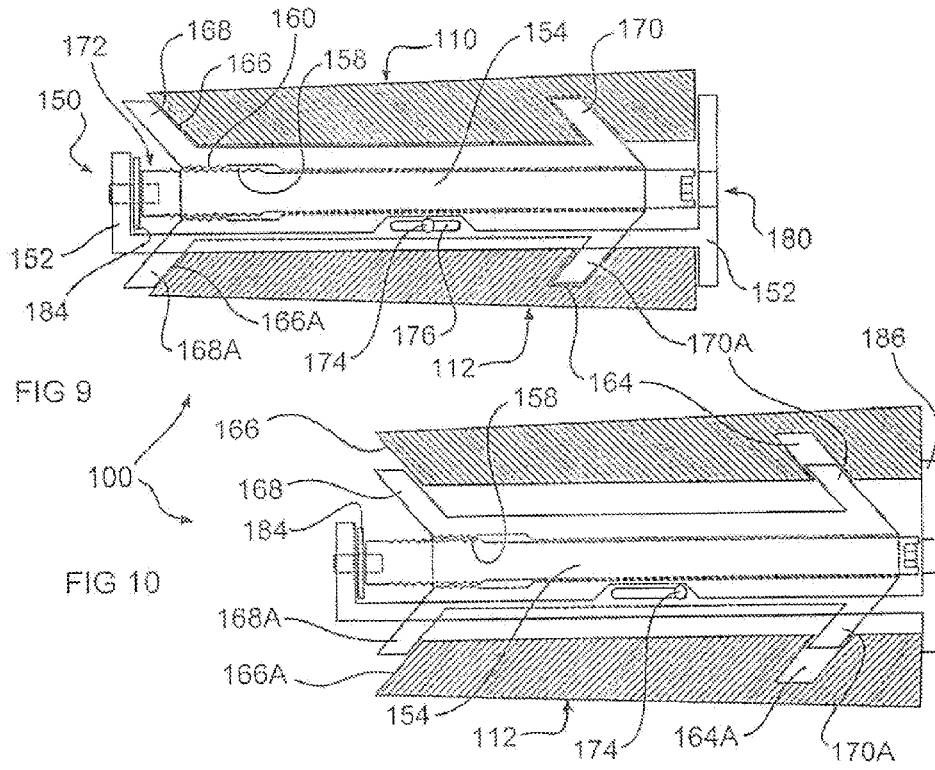
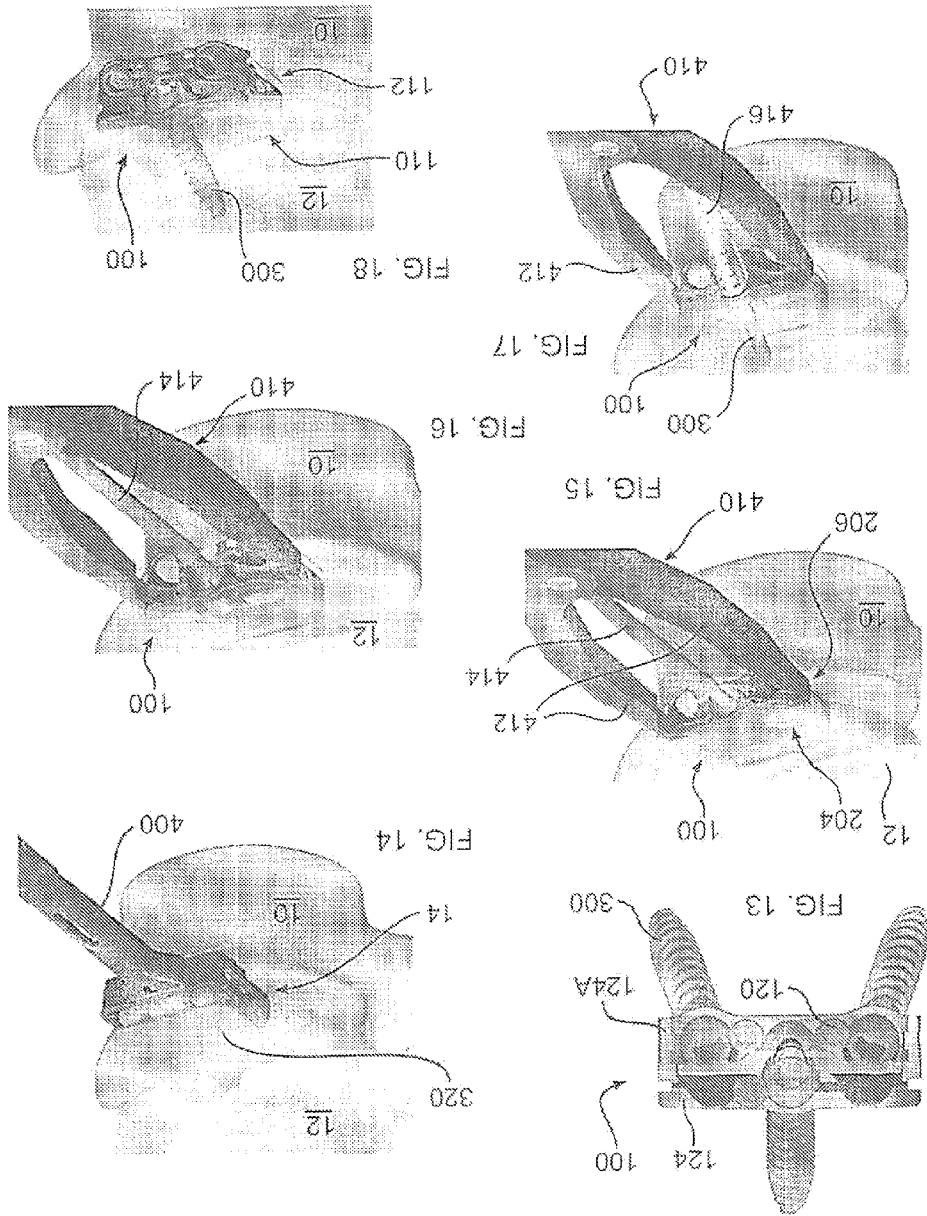

FIG 3









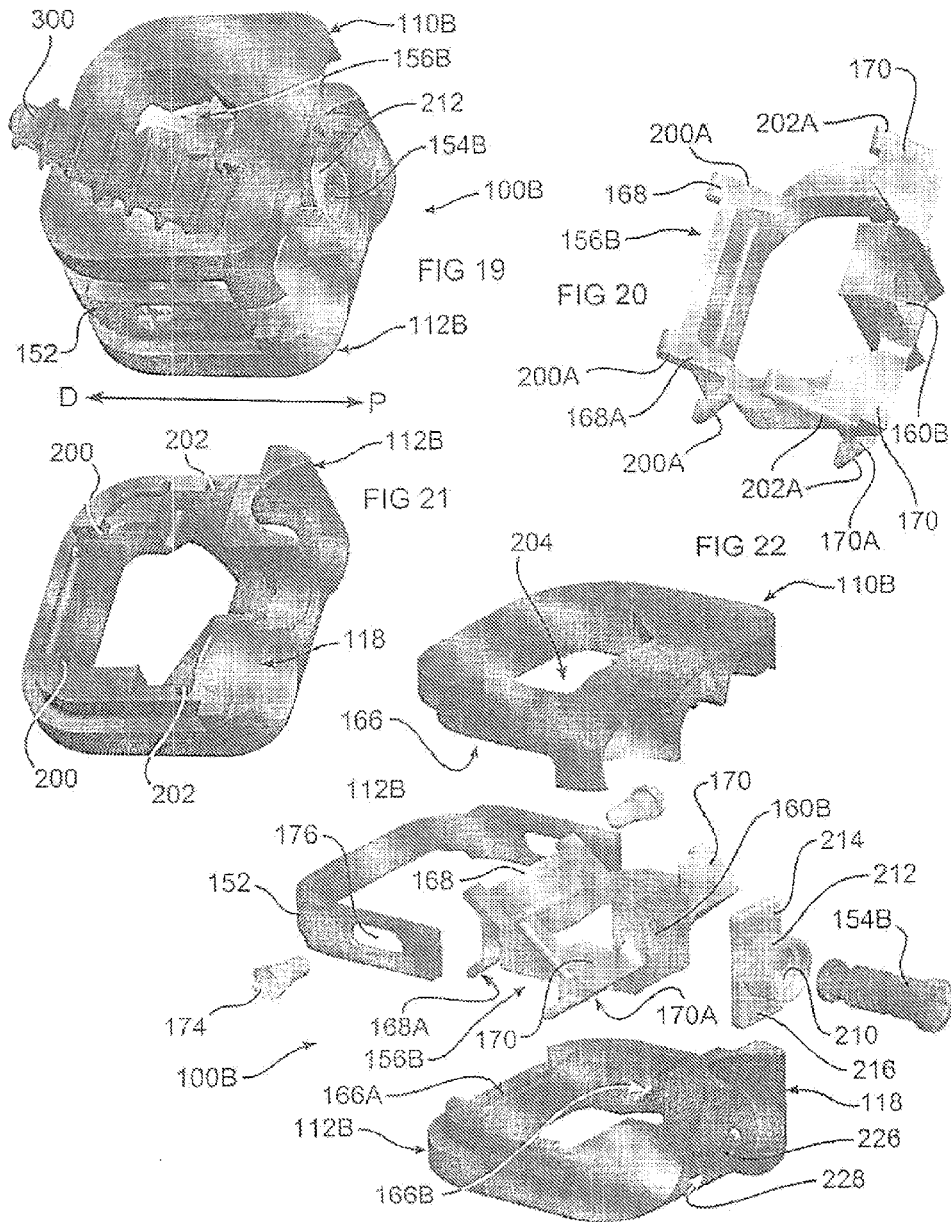

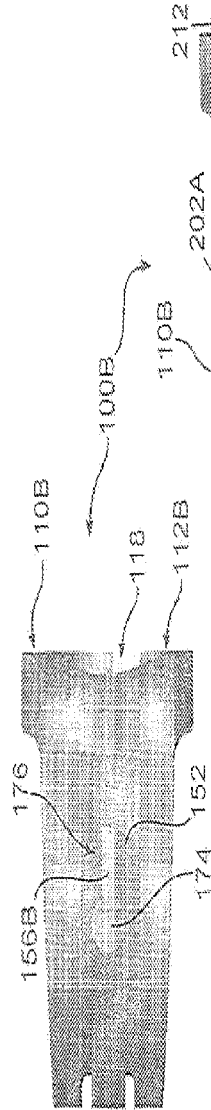

FIG 23

FIG 24

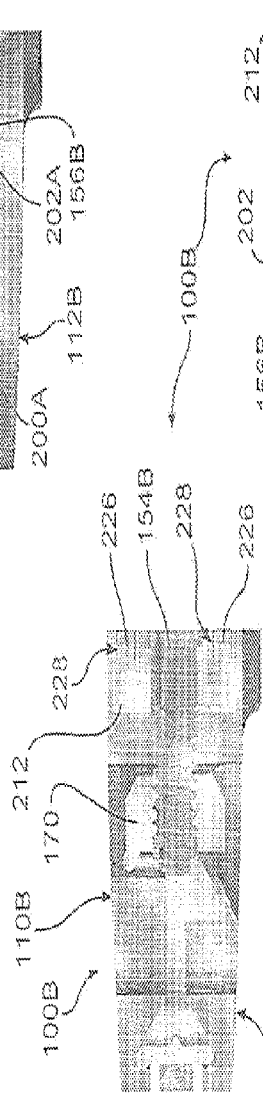

FIG 25

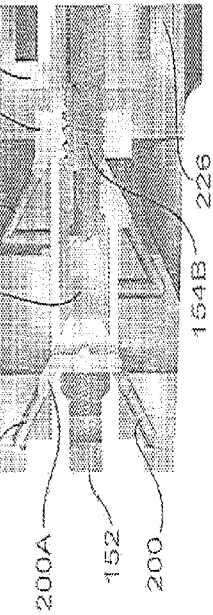
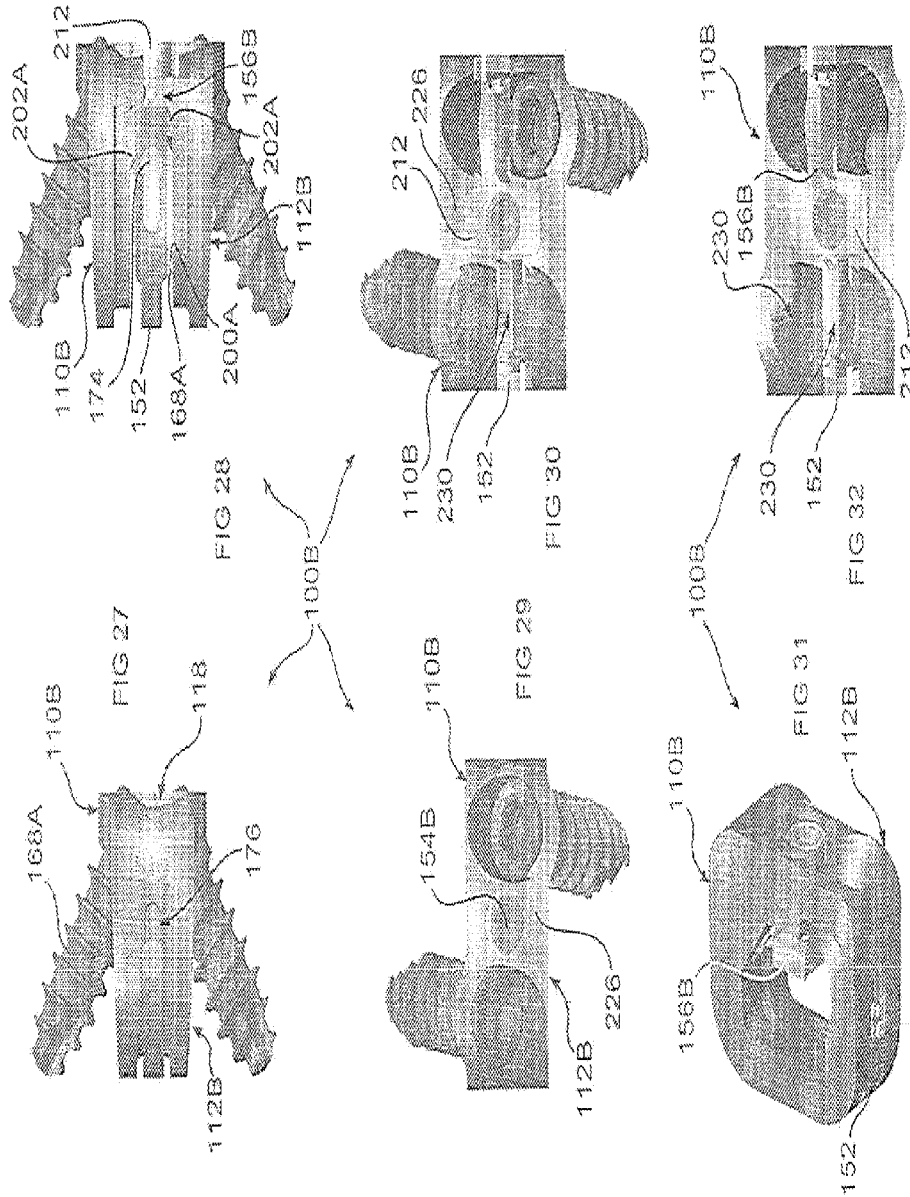
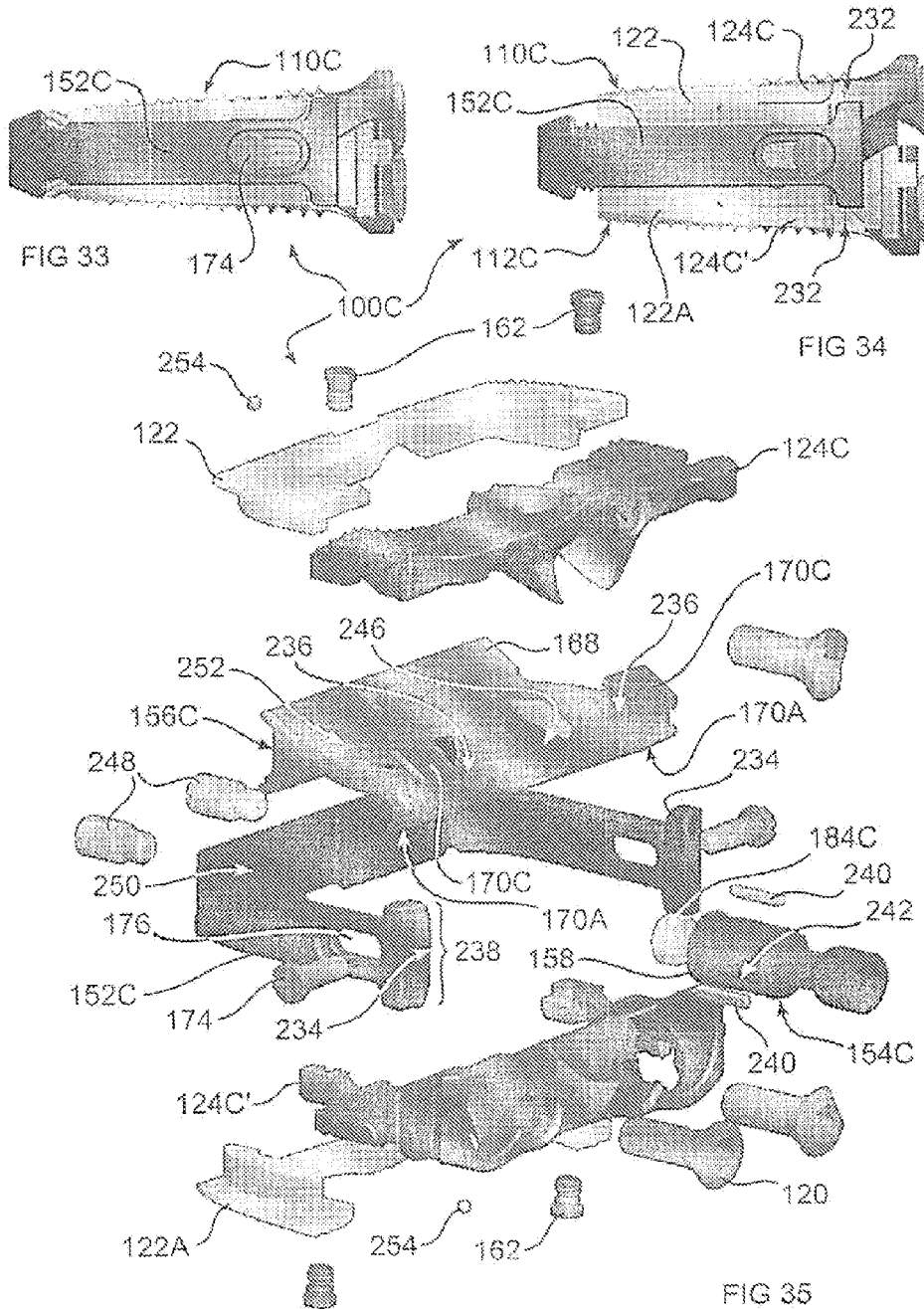
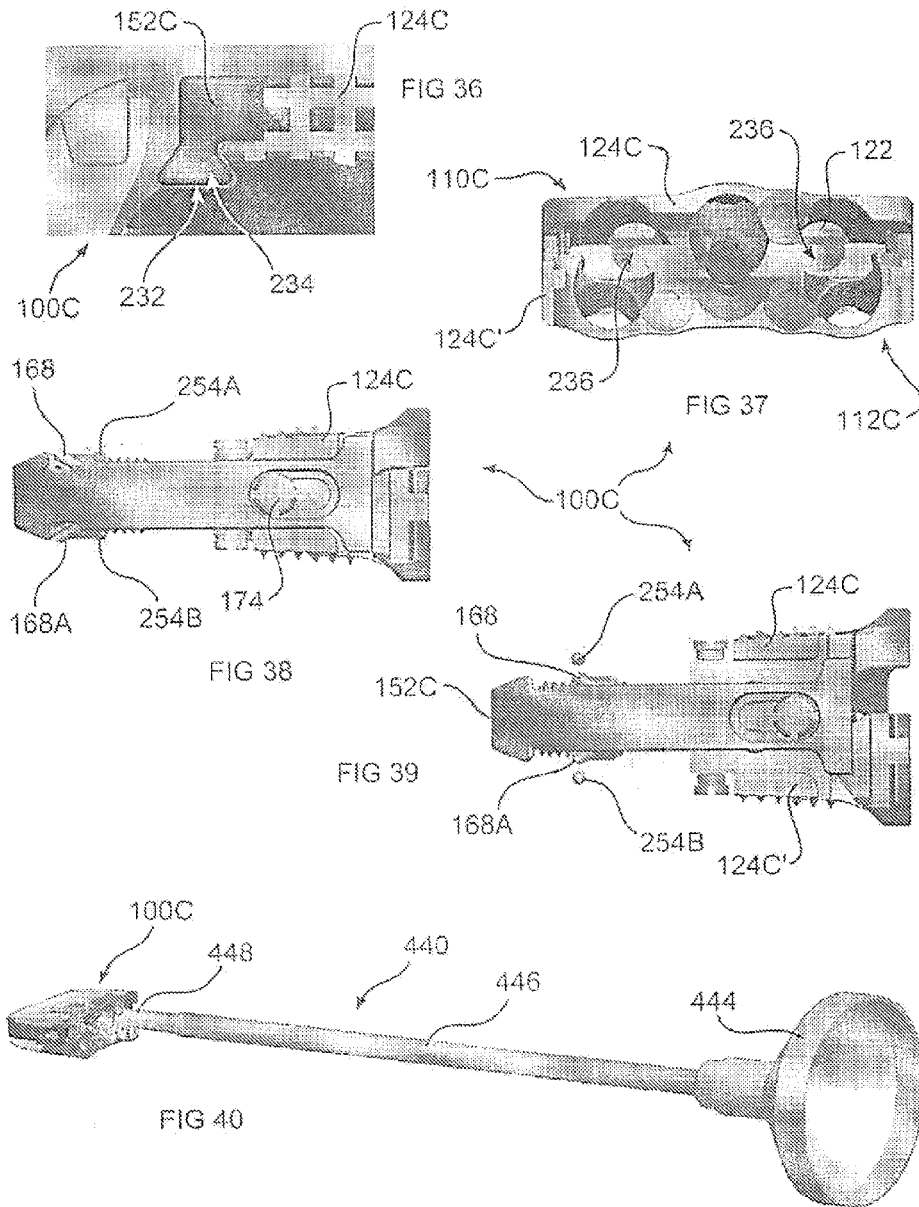

FIG 26







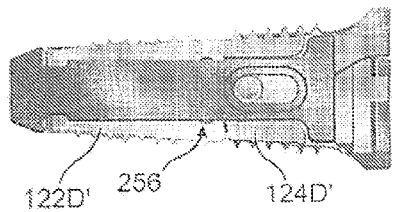

FIG 41

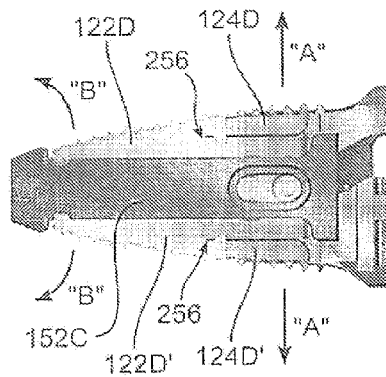

FIG 42

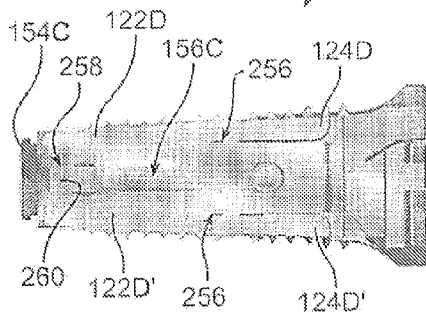

FIG 43

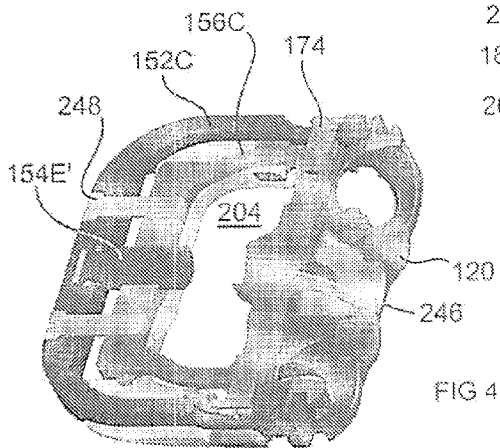

FIG 45

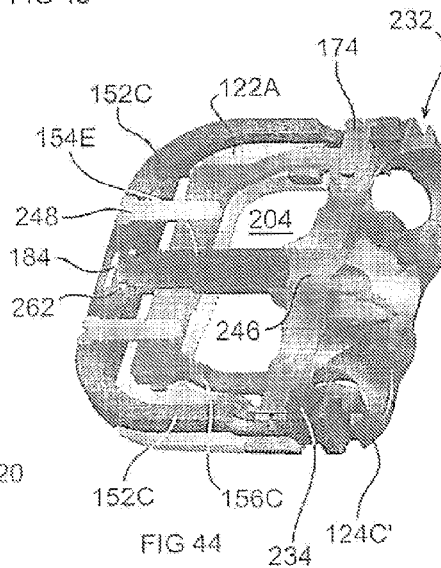

FIG 44

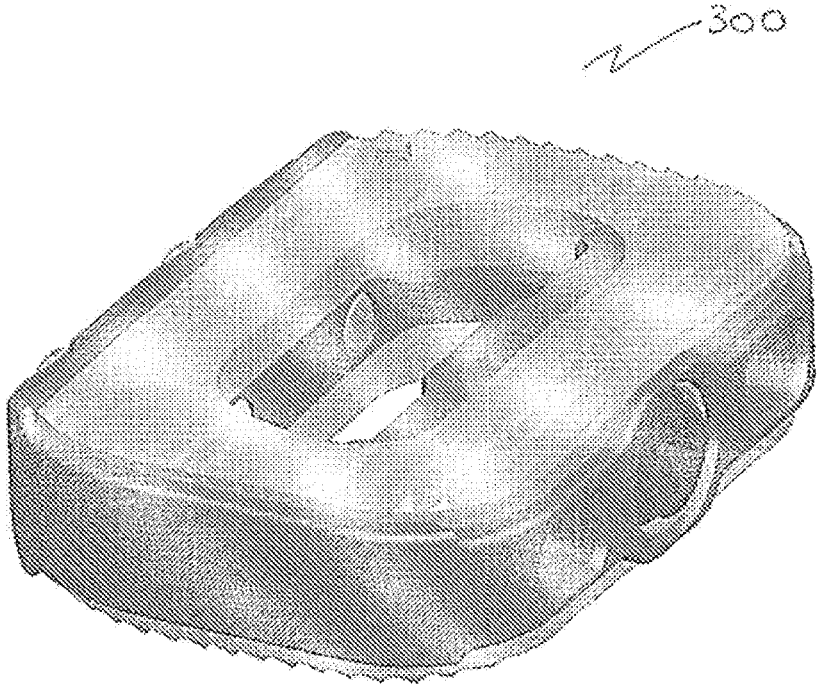

FIG. 46

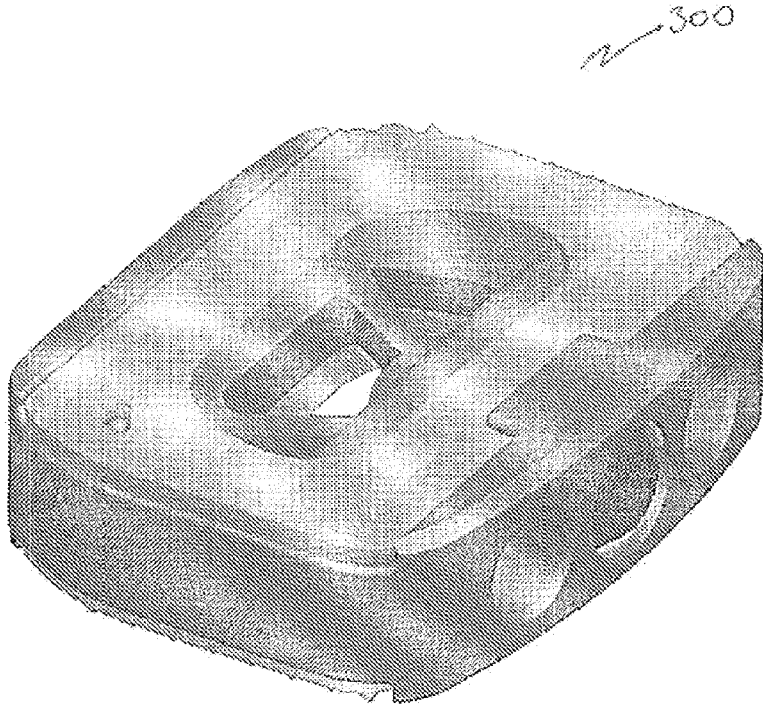

FIG. 47

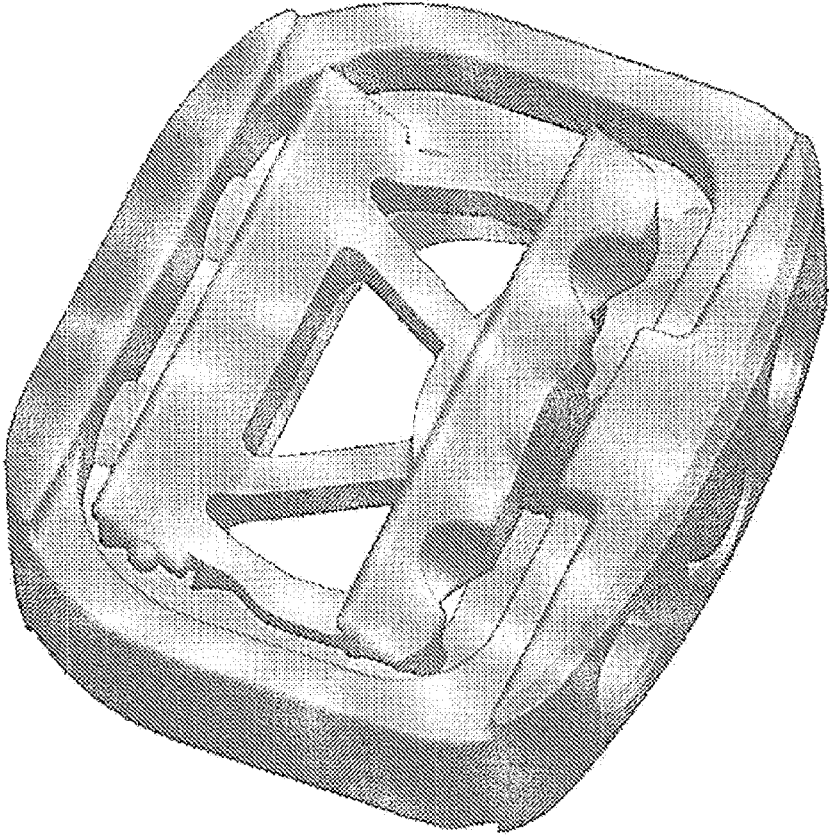

FIG. 48

Side View of Implant

Collapsed

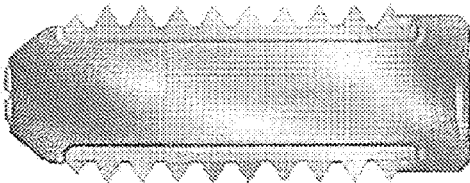

FIG. 49

Expanded

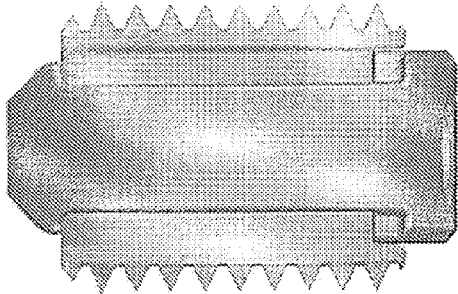

FIG. 50

Collapsed

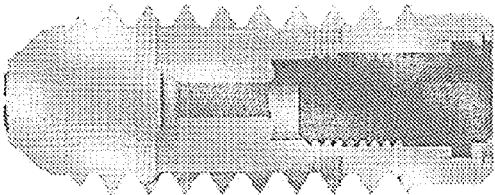

FIG. 51

Expanded

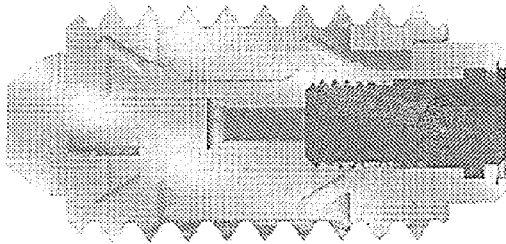

FIG. 52

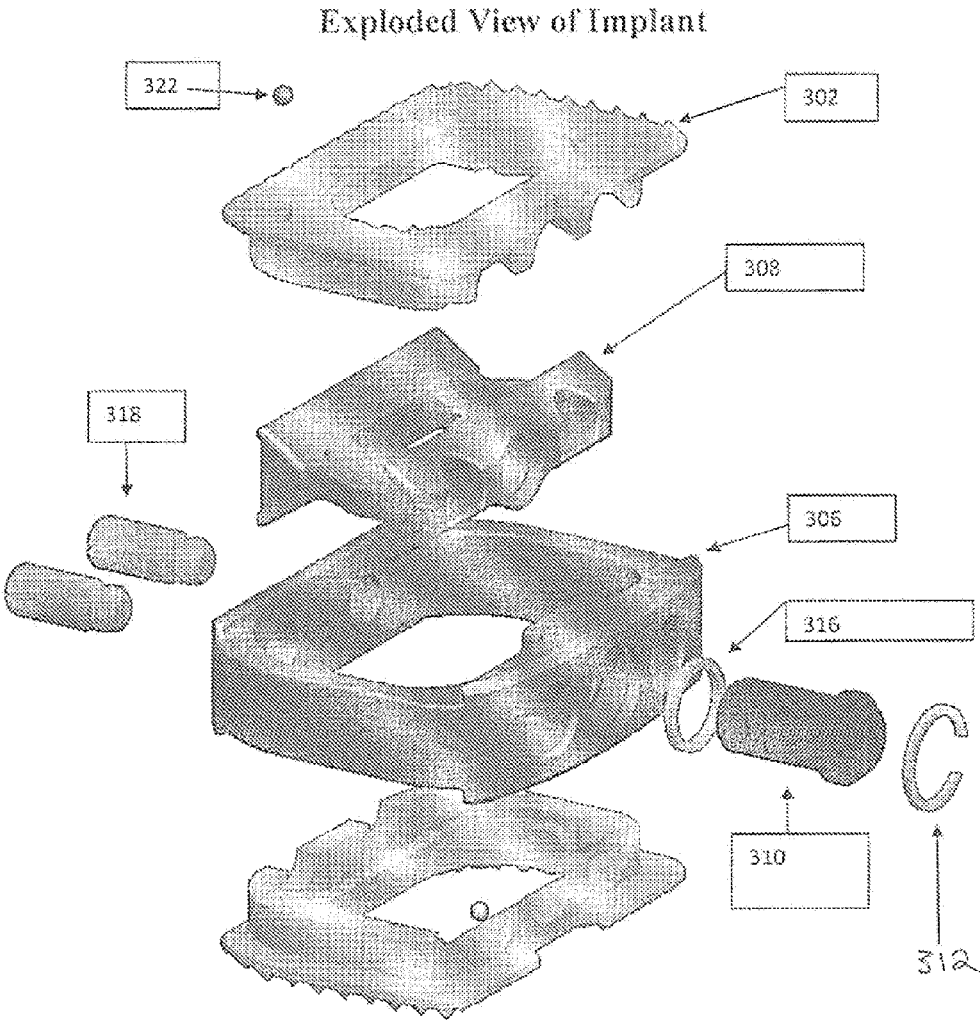

FIG. 53

EXPANDABLE INTERVERTEBRAL IMPLANT

REFERENCE TO RELATED APPLICATIONS

[0001] The present application is a continuation of U.S. patent application Ser. No. 14/676,323, filed Apr. 1, 2015, which is a continuation of U.S. patent application Ser. No. 13/836,005, filed Mar. 15, 2013, now U.S. Pat. No. 9,149,367. The references are incorporated by reference herein in their entirety.

FIELD OF THE INVENTION

[0002] This invention relates to stabilizing adjacent vertebrae of the spine by inserting an intervertebral implant, and more particularly an intervertebral implant that is adjustable in height.

BACKGROUND OF THE INVENTION

[0003] Bones and bony structures are susceptible to a variety of weaknesses that can affect their ability to provide support and structure. Weaknesses in bony structures have numerous potential causes, including degenerative diseases, tumors, fractures, and dislocations. Advances in medicine and engineering have provided doctors with a plurality of devices and techniques for alleviating or curing these weaknesses.

[0004] In some cases, the spinal column requires additional support in order to address such weaknesses. One technique for providing support is to insert a spacer between adjacent vertebrae.

SUMMARY OF THE INVENTION

[0005] In accordance with the disclosure, an implant for therapeutically separating bones of a joint, the implant defining a longitudinal axis extending between distal and proximal ends, the implant comprises a first endplate configured to engage a first bone of the joint, and having an opening through the endplate, and at least one ramped surface on a side opposite a bone engaging side; a second endplate configured to engage a second bone of the joint, and having an opening through the endplate, and at least one ramped surface on a side opposite a bone engaging side; a frame slideably connected to the first and second endplates to enable the first and second endplates to move relative to each other at an angle with respect to the longitudinal axis, in sliding connection with the frame; an actuator screw rotatably connected to the frame; and a carriage (a) forming an open area aligned with the openings in the first and second endplates and defining thereby a proximal carriage side and a distal carriage side with respect to the longitudinal axis, (b) threadably connected to the actuator screw, whereby rotation of the actuator screw moves the carriage with respect to the frame and the first and second endplates, the actuator screw not crossing between the proximal carriage side and the distal carriage side; and (c) including a plurality of ramps each mateable with at least one of the at least one ramped surfaces of the first and second endplates, wherein when the carriage is moved by rotation of the actuator screw, at least one of the at least one ramped surface of the first endplate and at least one of the at least one ramped surface of the second endplate each slide along at

least one of the plurality of ramps of the carriage to cause the endplates to move relative to each other in sliding connection with the frame.

[0006] In various embodiments thereof, the first and second endplates are confined by the frame to move relative to each other only along an axis substantially transverse to the longitudinal axis; at least one of the first and second endplates includes at least one aperture through which a fastener may pass to secure the implant to bone of the joint; the implant further includes a blocking mechanism configured to prevent backing out of a fastener passed through at least one of the first and second endplates and into body tissue; the blocking mechanism includes a blocking member slideably retained within a channel between an unblocking position and a blocking position in which a portion of the blocking member overlaps a portion of the faster; at least one of the first and second endplates includes one or more projections configured to engage bone of the joint when the implant is positioned between bones of the joint; at least one of the first and second endplates is composed of two interconnected portions of dissimilar materials; one of the dissimilar materials is metallic and includes at least one aperture through which a fastener may be passed to attach the implant to a bone of the joint; one dissimilar material is polymeric, and another dissimilar material is metallic; and, the implant further includes a polymeric material configured to press against the actuator screw to reduce a potential for unintended rotation of the actuator screw.

[0007] In further embodiments thereof, when the actuator screw is rotated in a first direction, a height of the implant transverse to the longitudinal axis is increased, and when the actuator screw is rotated in a second direction, a height of the implant transverse to the longitudinal axis is decreased; the actuator screw is threadably connected to the carriage along a proximal side of the carriage; the frame extends from the proximal end of the implant to the distal end of the implant, and the actuator screw is connected to the frame and threadably connected to the carriage along a distal side of the carriage; the frame is disposed within the proximal end of the implant; the frame extends from the proximal end of the implant towards the distal end of the implant; and, the implant further includes at least one post extending through the frame and into the carriage, slideably received in one of the frame or the carriage, thereby configured to maintain an alignment of the carriage along the longitudinal axis.

[0008] In yet further embodiments thereof, the implant further includes a first passage formed in a proximal end of at least one of the first and second endplates, and a second passage formed in a proximal side of the carriage, the first and second passages aligned to admit introduction of a therapeutic matter into the open area of the carriage when the implant is implanted between bones of the joint; the frame connects to the first and second endplates with a dovetail connection; the implant further includes at least one radiopaque marker positioned in connection with at least one of the first and second endplates, whereby an extent of movement of the connected endplate can be determined using imaging by a relative alignment of the radiopaque marker and a radiopaque element of the implant which does not move together with the connected endplate; ends of the at least one of the plurality of ramps of the carriage slide within grooves in at least one of the first and second endplates.

[0009] In another embodiment thereof, the frame includes an actuator screw bearing, a first tab extending away from the bearing in a first direction, and a second tab extending away from the bearing in a direction opposite to the upper tab, the first and second tabs forming edges; and the first and second endplates including grooves sized and dimensioned to slidably receive the edges of the first and second tabs, respectively.

[0010] In accordance with another embodiment of the disclosure, an implant for therapeutically separating bones of a joint, the implant defining a longitudinal axis extending between distal and proximal ends, the implant comprises a first endplate configured to engage a first bone of the joint, and having an opening through the endplate transverse to the longitudinal axis, and at least one ramped surface on a side opposite a bone engaging side; a second endplate configured to engage a second bone of the joint, and having an opening through the endplate transverse to the longitudinal axis, and at least one ramped surface on a side opposite a bone engaging side;

[0011] a frame slideably connected to the first and second endplates to enable the first and second endplates to move relative to each other at an angle substantially transverse to the longitudinal axis, in sliding connection with the frame; an actuator screw rotatably connected to the frame; and a carriage (a) forming an open area aligned with the openings in the first and second endplates and defining thereby a proximal carriage side and a distal carriage side with respect to the longitudinal axis, (b) threadably connected to the actuator screw, whereby rotation of the actuator screw moves the carriage with respect to the frame and the first and second endplates, the actuator screw not crossing between the proximal carriage side and the distal carriage side; (c) including a plurality of ramps each mateable with at least one of the at least one ramped surfaces of the first and second endplates, wherein when the carriage is moved by rotation of the actuator screw, at least one of the at least one ramped surface of the first endplate and at least one of the at least one ramped surface of the second endplate each slide along at least one of the plurality of ramps of the carriage to cause the endplates to move relative to each other in sliding connection with the frame; and (d) at least one passage formed in a proximal side of the carriage in communication with at least one proximal passage in at least one of the first or second endplates, the communicating passages configured to admit introduction of a therapeutic matter into the open area of the carriage when the implant is implanted between bones of the joint.

[0012] In accordance with the disclosure, a method of therapeutically separating bones of a joint, comprises inserting an implant defining a longitudinal axis extending between distal and proximal ends between bones of the joint, the implant including—a first endplate configured to engage a first bone of the joint, and having an opening through the endplate, and at least one ramped surface on a side opposite a bone engaging side; a second endplate configured to engage a second bone of the joint, and having an opening through the endplate, and at least one ramped surface on a side opposite a bone engaging side; a frame slideably connected to the first and second endplates to enable the first and second endplates to move relative to each other at an angle with respect to the longitudinal axis, in sliding connection with the frame; an actuator screw rotatably connected to the frame; and a carriage (a) forming an open area

aligned with the openings in the first and second endplates and defining thereby a proximal carriage side and a distal carriage side with respect to the longitudinal axis, (b) threadably connected to the actuator screw, whereby rotation of the actuator screw moves the carriage with respect to the frame and the first and second endplates, the actuator screw not crossing between the proximal carriage side and the distal carriage side; and (c) including a plurality of ramps each mateable with at least one of the at least one ramped surfaces of the first and second endplates, wherein when the carriage is moved by rotation of the actuator screw, at least one of the at least one ramped surface of the first endplate and at least one of the at least one ramped surface of the second endplate each slide along at least one of the plurality of ramps of the carriage to cause the endplates to move relative to each other in sliding connection with the frame; and rotating the actuator screw after the implant is inserted to move the first and second endplates relatively farther apart to separate bones of the joint.

BRIEF DESCRIPTION OF THE DRAWINGS

[0013] A more complete understanding of the present invention, and the attendant advantages and features thereof, will be more readily understood by reference to the following detailed description when considered in conjunction with the accompanying drawings, in which:

[0014] FIG. 1 depicts an implant of the disclosure, together with three mounted bone screws;

[0015] FIG. 2 depicts the implant of FIG. 1, in a compressed or reduced height configuration;

[0016] FIG. 3 depicts the implant of FIG. 1, in an expanded or increased height configuration;

[0017] FIG. 4 depicts a carriage and frame of the implant of FIG. 1;

[0018] FIG. 5 depicts an endplate of the implant of FIG. 1;

[0019] FIG. 6A depicts a sagittal cross-section of the implant of FIG. 2;

[0020] FIG. 6B depicts a sagittal cross-section of the implant of FIG. 3;

[0021] FIG. 7A depicts a transverse cross-section of the implant of FIG. 2;

[0022] FIG. 7B depicts a transverse cross-section of the implant of FIG. 3;

[0023] FIG. 8 depicts an exploded view of the implant of FIG. 1;

[0024] FIG. 9 depicts a diagrammatic view of aspects of an implant in accordance with the disclosure, in a reduced height configuration;

[0025] FIG. 10 depicts the implant of FIG. 9, in an expanded height configuration;

[0026] FIG. 11 depicts the implant of FIG. 1, implanted between adjacent vertebrae;

[0027] FIG. 12A depicts a front view of the implant of FIG. 1 having an alternative blocking configuration, in a reduced height configuration;

[0028] FIG. 12B depicts the implant of FIG. 12A in an expanded height configuration;

[0029] FIG. 13 depicts the implant of FIG. 12B, with bone screws inserted into the implant;

[0030] FIG. 14 depicts inserting a trial of the disclosure, the trial representing an implant of the disclosure, into the disc space, using a trialing tool of the disclosure;

[0031] FIG. 15 depicts an implantation and actuating tool of the disclosure inserting an implant of the disclosure into the disc space;

[0032] FIG. 16 depicts the implant and tool of FIG. 14, the tool having expanded the implant;

[0033] FIG. 17 depicts the implant and tool of FIG. 15, and a bone screw driver inserting a bone screw;

[0034] FIG. 18 depicts the implant of FIG. 13 secured between vertebrae;

[0035] FIG. 19 depicts an implant of the disclosure including a proximally driven carriage;

[0036] FIG. 20 depicts the carriage of the implant of FIG. 19;

[0037] FIG. 21 depicts a lower endplate of the implant of FIG. 19;

[0038] FIG. 22 depicts an exploded view of the implant of FIG. 19;

[0039] FIG. 23 depicts a reduced height configuration of the implant of FIG. 19;

[0040] FIG. 24 depicts an expanded height configuration of the implant of FIG. 23;

[0041] FIG. 25 depicts a cross section of the implant of FIG. 23;

[0042] FIG. 26 depicts a cross section of the implant of FIG. 24;

[0043] FIG. 27 depicts the implant of FIG. 23, with bone screws inserted into the implant;

[0044] FIG. 28 depicts the implant of FIG. 24, with bone screws inserted into the implant;

[0045] FIG. 29 depicts a front view of the implant of FIG. 27;

[0046] FIG. 30 depicts a front view of the implant of FIG. 28;

[0047] FIG. 31 depicts a perspective view of the implant of FIG. 19, without bone screws inserted;

[0048] FIG. 32 depicts a front view of the implant of FIG. 30, without bone screws inserted;

[0049] FIG. 33 depicts a side view of an alternative implant in accordance with the disclosure, in a reduced height configuration;

[0050] FIG. 34 depicts the implant of FIG. 33, in an expanded height configuration;

[0051] FIG. 35 depicts an exploded view of the implant of FIG. 33;

[0052] FIG. 36 depicts an enlarged cross section of a dovetail connection of the implant of FIG. 33;

[0053] FIG. 37 depicts a front view of the implant of FIG. 33, illustrating passages for bone graft material;

[0054] FIG. 38 depicts a simulating of radiographic imaging of an implant of the disclosure, illustrating radiographic markers, the implant in a reduced height configuration;

[0055] FIG. 39 depicts the implant of FIG. 38, the implant in an expanded height configuration;

[0056] FIG. 40 depicts a bone funnel of the disclosure, used in connection with an implant of the disclosure;

[0057] FIG. 41 depicts an alternative implant of the disclosure, including hinged endplates, in a reduced height configuration;

[0058] FIG. 42 depicts the implant of FIG. 41, in an expanded configuration;

[0059] FIG. 43 depicts the implant of FIG. 41, with a frame portion removed;

[0060] FIG. 44 depicts a cross section of an alternative implant of the disclosure, in perspective, having an elongate actuator screw; and

[0061] FIG. 45 depicts the implant of FIG. 44, having a shortened actuator screw.

[0062] FIGS. 46-53 illustrate another embodiment of an implant according to the present invention.

DETAILED DESCRIPTION OF THE INVENTION

[0063] As required, detailed embodiments are disclosed herein; however, it is to be understood that the disclosed embodiments are merely examples and that the systems and methods described below can be embodied in various forms. Therefore, specific structural and functional details disclosed herein are not to be interpreted as limiting, but merely as a basis for the claims and as a representative basis for teaching one skilled in the art to variously employ the present subject matter in virtually any appropriately detailed structure and function. Further, the terms and phrases used herein are not intended to be limiting, but rather, to provide an understandable description of the concepts.

[0064] The terms “a” or “an”, as used herein, are defined as one or more than one. The term plurality, as used herein, is defined as two or more than two. The term another, as used herein, is defined as at least a second or more. The terms “including” and “having,” as used herein, are defined as comprising (i.e., open language).

[0065] Implants of the disclosure allow continuous expansion and retraction within a range of expansion. Lordosis of certain embodiments of implants herein can be custom tailored to fit the anatomy of a specific patient. Additionally, implants of the disclosure enable distraction of vertebral bodies to a desired height, but can also be collapsed and repositioned, as therapeutically indicated for the patient.

[0066] With reference to FIGS. 1-3, implant or implant 100 is operative, when positioned between adjacent bones of a joint, such as for example vertebrae 10, 12 (shown in FIG. 11), to stabilize a joint formed by adjacent vertebrae. Implant 100 has a collapsed state or height, illustrated in FIG. 2, and an expanded state or height, illustrated in FIG. 3. Implants 100 of the disclosure may be inset into the intervertebral disc space at a collapsed height, and then expand axially (superior/inferior) to restore height loss in the disc space. The implant provides distraction as well as achieves optimal height restoration. When inserted in a collapsed state, implants 100 reduce impaction to tissue in the joint space during insertion, and form the least visually blocking or obstructing profile.

[0067] Implant 100 includes two separable endplates 110, 112. A surface 114 of an endplate 110, 112 can be provided with teeth or other projections 116 which can penetrate body tissue to reduce a likelihood of migration of implant 100 after implantation. Implant 100 is further secured with one or more bone screws 300, which pass through bone screw socket 118 within implant 100, and into body tissue of the patient. In the embodiment illustrated in FIGS. 1-3, three sockets 118 for three bone screws are provided, the bone screws 300 further retained in connection with implant 100 by blocking fasteners 120. Bone screw 300 can be a polyaxial screw, and sockets 118 correspondingly shaped, whereby bone screw 300 may be inserted into body tissue at

an optimal angle with respect to implant 100, whereby optimal purchase may be obtained, or certain body tissue may be avoided.

[0068] Endplates 110, 112 are moveably connectable to an actuator 150 operable to change a relative relationship of endplates 110 and 112. Actuator 150 includes a frame 152 rotatably supporting an actuator screw 154, and a moveable carriage 156. As actuator screw 154 rotates within frame 152, carriage 156 slides within frame 152, driven by cooperation between threads 158 (FIG. 8) upon actuator screw 154, and mating threads 160 within carriage 156. In the embodiment of FIGS. 1-3, endplates 110 and 112 are formed in two connected portions, including a portion 122, 122A which can be polymeric, and a portion 124, 124A, which can be metallic. The portions are joined in the embodiment shown by screws 162, although other methods of combining the two connected portions 122, 124 or 122A and 124A may be used, including a dovetail connection, or adhesive, possibly in combination with each other, or with endplate connector screws 162. Metallic portions 124, 124A can provide greater strength for portions of implant 100 which are under relatively greater stress, for example portions through which a fastener may pass to anchor implant 100 within the body. While portions 122, 122A, 124, 124A are described as polymeric or metallic, it should be understood that other materials may be used, and that the portions can be of dissimilar materials.

[0069] With reference to FIG. 2, it may be seen that implant 100 is in a compressed state, having a lower height relative to an expanded state, as shown in FIG. 3. A functioning of device 100 may be best understood with reference to FIGS. 9-10, which correlate with FIGS. 2-3, respectively, but which present a simplified view having certain elements eliminated or exaggerated, to ease understanding. Endplates 110 and 112 are provided with ramped channels 164, 164A, and an open ramp 166, 166A, sized to slidably receive ramps 168, 168A and 170, 170A disposed upon carriage 156. While two mating channels and ramps are illustrated for each endplate 110, 112, it should be understood that one, or more than two, sets of channels and/or ramps may be provided. Further, channels 164, 164A may alternatively be formed as ramps. However, a channel can operate to enable a reduction of height, having an opposing ramp face, whereby rotation of actuator screw 154 in an opposite direction to expansion can drive endplates 110, 112 together, for example when pressure from body tissue is insufficient to collapse endplates 110, 112. Additionally, at least one channel can operate to foster the maintenance of a connection between carriage 156 and an endplate 110, 112.

[0070] Carriage 156 is supported by frame 152 by lateral engagement means, in this embodiment two support screws 174 engaged with carriage 156, and passable through respective channels 176 formed in frame 152. Distal end 172 of actuator screw 154 provides additional support for carriage 156. Actuator screw 154 is supported by a set screw 178, which passes through and is rotatably supported within frame 152.

[0071] An actuator access port 180 permits passage of a tool, for example a hex driver (not shown), into engagement with a proximal end 182 of actuator screw 154. As actuator screw 154 is turned, distal end 172 bears against a thrust washer 184, and an end portion of frame 152. As actuator screw 154, carriage 156 is driven along actuator screw by interaction of threads 158 and 160. As carriage 156 moves,

endplates 110, 112 are urged to move along ramps 168, 168A and 170, 170A, moving relatively apart, and increasing a height of implant 100. Endplates 110, 112 are prevented from moving together with carriage 156 by abutting against an end portion 186 of frame 152. In a given orientation, one of endplate 110 and 112 is an upper endplate with respect to an orientation in a standing patient. However, implant 100 may, in some embodiments, be implantable in either of opposite orientations, and therefore designations of upper and lower are provided for ease of understanding, only. It should be understood that only one of endplate 110, 112 may be moveable with respect to the other. For example, in one embodiment, ramps 168A, 170A may not be provided, and endplate 112 may be attached to frame 152.

[0072] FIG. 11 illustrates an implant 100 of the disclosure implanted between adjacent vertebrae 10, 12. Frame 152 defines a distal or leading end 152A which is inserted first into the body, and a proximal or trailing end 152B which passes last into the body, the distal and proximal ends defining a longitudinal axis extending therebetween. Implant 100 can be inserted into the body, and into a position between vertebrae, using minimally invasive methods, for example using a small incision, and implant 100 may be passed through a cannula or other structure which maintains a pathway through body tissue. Implant 100 may be inserted into the spinal column through any approach, including anterior, anterolateral, lateral, or posterolateral. A portion of the disc annulus, and nucleus pulposus may be removed in order to form a space into which implant 100 may be inserted. When implant 100 is in a compressed, or reduced height configuration, dovetail guides 200, 202 can be provided to foster maintenance of a relative orientation of upper and lower endplates during insertion or removal of device 100. Dovetail guides 200, 202 further stabilize endplates 110, 112 during expansion, and when implant 100 is expanded. Dovetail guides 200, 202, can have the form of a tongue and groove configuration, or other sliding mating configuration, with ends of ramps 168, 168A, for example.

[0073] Implant 100 can be inserted configured to have a lower height profile, as shown in FIG. 2, whereby an extent of distraction of body tissue may be reduced during insertion. Moreover, to the extent that implant 100 is used to open a pathway towards an implantation site, trauma to adjacent tissue is reduced relative to inserting an implant having a final height profile. Once implant 100 is positioned between adjacent vertebrae, actuator screw is rotated by a tool. The tool may be positioned entirely within the body, or can extend from in interior of the body to outside the body, for example having a driving tip at one end and having a handle at an opposite end, with a shaft extending into the body between each end.

[0074] Once actuator screw 154 has been rotated to separate endplates 110, 112 a desired amount, the tool is removed. At this point, actuator screw 154 may be secured in place, for example using a mechanical block, or an adhesive, to prevent unintended rotation of actuator screw 154. As carriage 156 is slideably moved by rotation of actuator screw 154, a ramp 166, 166A or a ramped surface of channel 164, 164A of at least one of endplate 110, 112 slides against at least one ramp 168, 168A, 170, or 170A of carriage 156, to cause the endplate to move along an axis transverse to the longitudinal axis of the frame, to increase a height of the implant. Rotation of actuator screw 154 in an

opposite direction causes movement along an axis transverse to the longitudinal axis of the frame to decrease a height of the implant.

[0075] Polymeric insets, or a polymeric square nut, for example PEEK, can be provided, engageable with threads 158 or other portion of actuator screw 154, to provide additional friction to prevent height loss under load, particularly under cyclic loading. Similarly, once bone screws 300 have been inserted, blocking elements 120 may be rotated to extend over an end of bone screw head 302, preventing screw 300 from backing out. A similar mechanical block (not shown) may be provided for actuator screw 154.

[0076] With reference to FIGS. 1-3, 5-8, it may be seen that a socket 118 for a polyaxial screw head 302 can be formed entirely within one of upper or lower endplate 110, 112, or may be formed partially within each of endplate 110 and 112, whereby when implant 100 has been expanded to a final height, the proportions of an interior of socket 118 are correct or substantially correct for retaining screw head 302. For example, in FIG. 8, metallic portion 124 forms an upper portion 190 of socket 118, and mating metallic portion 124A forms a lower portion 192 of socket 118. In the embodiment illustrated in the figures, there are three sockets 118, and all are formed of upper and lower portions. However, there may be more or fewer sockets 118, and one or more sockets may be formed entirely in an upper or lower endplate.

[0077] In an embodiment, implant 100 of the disclosure provides an actuator that translates relative to the body by means of a threaded actuator screw 154. Ramps 168, 168A and 170, 170A on a carrier 152 mate with channels 164, 164A, and or ramps 166, on endplates 110, 112. Linear translation of carriage 156 causes endplates 110, 112 to expand implant 100 along an S/I axis with respect to the body. There can be dovetail guides that capture endplates 110, 112 when collapsing the implant.

[0078] Assembly screws 162 fasten endplates made of dissimilar materials, for example PEEK polymeric portions 122, 122A to Titanium metallic portions 124, 124A. A dovetail and press fit design can be used to connect the dissimilar endplate portions. A PEEK bushing or washer 184 is used between the threaded actuator screw 154 and frame 152 to minimize friction during expansion of implant 100. Support screws 174 and channels 176 cooperate to form side or lateral stabilizers, and set screw 178 supports a nose or leading end of carriage 156. Additionally, cooperating slots and projections (not shown) in carriage 156 and frame 152 can be provided for further relative guidance and stability.

[0079] In one embodiment, three bone screws 300 are used to provide fixation into adjacent vertebral bodies, two screws 300 passing through implant 100 and into one vertebra, and one screw 300 passing through implant 100 into another vertebra, although other combinations may be used. Bone screws 300 can have spherical or otherwise curved heads, facilitating insertion at a desired angle, or may be provided to mate with socket 118 in a fixed orientation, particularly depending on a diameter of a neck portion of screw 300. Cam style blocking fasteners 120 can be used to block bone screws 300 from backing out after being inserted.

[0080] Implants of the disclosure enable a continuous expansion and retraction over a range of displacements according to predetermined dimensions of a specific implant 100 design. This provides the ability to distract vertebral

bodies to a desired height, but also to collapse the implant 100 for repositioning, if therapeutically advantageous for the patient. Endplates 110, 112 may be shaped to form planes or surfaces which converge relative to each, to provide for lordosis, and can be provided with openings, forming a graft chamber 204 through the openings and between the respective openings through which bone may grow, and into which bone graft material may be placed. Implant 100 may be used to distract, or force bones of a joint apart, or may be used to maintain a separation of bones created by other means, for example a retractor.

[0081] Implant 100 may be fabricated using any biocompatible materials known to one skilled in the art, having sufficient strength, flexibility, resiliency, and durability for the patient, and for the term during which the device is to be implanted. Examples include but are not limited to metal, such as, for example titanium and chromium alloys; polymers, including for example, PEEK or high molecular weight polyethylene (HMWPE); and ceramics. There are many other biocompatible materials which may be used, including other plastics and metals, as well as fabrication using living or preserved tissue, including autograft, allograft, and xenograft material.

[0082] Portions or all of the implant may be radiopaque or radiolucent, or materials having such properties may be added or incorporated into the implant to improve imaging of the device during and after implantation.

[0083] For example, metallic portions 124, 124A of endplates 110, 112 may be manufactured from Titanium, or a cobalt-chrome-molybdenum alloy, Co—Cr—Mo, for example as specified in ASTM F1537 (and ISO 5832-12). The smooth surfaces may be plasma sprayed with commercially pure titanium, as specified in ASTM F1580, F1978, F1147 and C-633 (and ISO 5832-2). Polymeric portions 122, 122A may be manufactured from ultra-high molecular weight polyethylene, UHMWPE, for example as specified in ASTM F648 (and ISO 5834-2). In one embodiment, PEEK-OPTIMA (a trademark of Invibio Ltd Corp, United Kingdom) may be used for one or more components of implant 100. For example, polymeric portions 122, 122A can be formed with PEEK-OPTIMA, which is radiolucent, whereby bony ingrowth may be observed. Other polymeric materials with suitable flexibility, durability, and biocompatibility may also be used.

[0084] In accordance with the invention, implants of various sizes may be provided to best fit the anatomy of the patient. Components of matching or divergent sizes may be assembled during the implantation procedure by a medical practitioner as best meets the therapeutic needs of the patient, the assembly inserted within the body using an insertion tool. Implants of the invention may also be provided with an overall angular geometry, for example an angular mating disposition of endplates 110, 112, to provide for a natural lordosis, or a corrective lordosis, for example of from 0° to 6° for a cervical application, although much different values may be advantageous for other joints. Lordotic angles may also be formed by shaping one or both of plates 110, 112 to have relatively non-coplanar surfaces. Expanded implant heights, for use in the cervical vertebrae for example, may typically range from 7 mm to 12 mm, but may be larger or smaller, including as small as 5 mm, and as large as 16 mm, although the size is dependent on the patient, and the joint into which an implant of the invention is to be implanted. Implants 100 may be implanted within

any level of the spine, and may also be implanted in other joints of the body, including joints of the hand, wrist, elbow, shoulder, hip, knee, ankle, or foot.

[0085] In accordance with the invention, a single implant 100 may be used, to provide stabilization for a weakened joint or joint portion. Alternatively, two, three, or more implants 100 may be used, at a single joint level, or in multiple joints. Moreover, implants 100 may be combined with other stabilizing means.

[0086] Additionally, implant 100 may be fabricated using material that biodegrades in the body during a therapeutically advantageous time interval, for example after sufficient bone ingrowth has taken place. Further, implant 100 is advantageously provided with smooth and/or rounded exterior surfaces, which reduce a potential for deleterious mechanical effects on neighboring tissues.

[0087] Any surface or component of the invention may be coated with or impregnated with therapeutic agents, including bone growth, healing, antimicrobial, or drug materials, which may be released at a therapeutic rate, using methods known to those skilled in the art.

[0088] Devices of the disclosure provide for adjacent vertebrae to be supported during flexion/extension, lateral bending, and axial rotation. In one embodiment, implant 100 is indicated for spinal arthroplasty in treating skeletally mature patients with degenerative disc disease, primary or recurrent disc herniation, spinal stenosis, or spondylosis in the lumbosacral spine (L1-S1). Degenerative disc disease is advantageously defined as discogenic back pain with degeneration of the disc confirmed by patient history and radiographic studies, with or without leg (radicular) pain. Patients are advantageously treated, for example, who may have spondylolisthesis up to Grade 1 at the involved level. The surgery position implant 100 may be performed through an Anterior, Anterolateral, Posterolateral, and/or Lateral approach.

[0089] In a typical embodiment, implant 100 has a uncompressed height, before insertion, of 12 to 18 mm, and may advantageously be provided in cross-sections of 23×32 mm, 26×38 mm and 26×42 mm, with 4, 8, 12, or 16 degree lordotic angles, although these are only representative sizes, and substantially smaller or larger sizes can be therapeutically beneficial. In one embodiment an implant 100 in accordance with the instant disclosure is sized to be inserted using an MIS approach (a reduced incision size, with fewer and shorter cuts through body tissue).

[0090] Implant 100 may advantageously be used in combination with other known or hereinafter developed forms of stabilization or fixation, including for example rods and plates.

[0091] Referring now to FIGS. 13-18, implant 100 can be insert it into the intervertebral disc space at a collapsed height, and then expand it to restore the disc space height. Implant 100 provides distraction as well as achieves optimal sagittal balance. As discussed, there are multiple methods and approaches by which implant 100 can be inserted. FIGS. 14-18 illustrate one possible method and approach of the disclosure. While a series of numbered steps are described, it should be understood that there can be numerous other steps pertaining to the procedure, and that the steps described emphasize useful steps in the deployment of implant 100 of the disclosure.

[0092] Step 1: Approach—An approach to the desired section of the spine is performed using surgical instruments such as scalpels and retractors, for example using minimally invasive techniques.

[0093] Step 2: Preparation—Disc preparation instruments can be used to expose the disc and remove disc material, for example using rongeurs and other suitable instruments (not shown), to create a disc space 14.

[0094] Step 3: Trialing—As may be seen in FIG. 14, trialing for implant footprint, height and wedge angle is performed to indicate which size or type of implant 100 is to be used. An expandable trial, static trials, or a combination of each may be used. In FIG. 14, trial implant 320 is trial fit using trial insertion tool 400.

[0095] Step 4: Insertion—Graft material or other therapeutically beneficial material is packed into graft chamber 204 of the selected implant 100 when it is collapsed or partially expanded. As may be seen in FIG. 15, implant 100 is inserted into disc space 14 using insertion tool 410. Tool engagement formations 206 are provided on opposite sides of frame 152 or one of endplate 124 or 124A, as can be seen in FIG. 1. Tool arms 412 securely and releasably engage tool engagement formations 206, and align an expansion driver 414 with actuator screw 154.

[0096] Step 5: Expansion—In FIG. 16, implant 100 is expanded, as described herein, by turning actuator screw 154 using expansion driver 414. After expansion, additional bone graft material can be packed through graft portals 208 into the central graft chamber 204 using a bone funnel 440 (FIG. 40). A push rod (not shown) can be used for driving graft material through funnel 440.

[0097] Step 6: Hole Preparation—Bone screw pilot holes can be formed into one or more adjacent vertebrae, prepared using, for example, awls, drills and or taps. Multiple pilot holes can be prepared first, or pilot holes can be prepared one at a time, before the insertion of each screw 300. During any of the steps herein, imaging can be carried out to avoid damage to adjacent tissue.

[0098] Step 7: Screw Insertion—In FIG. 17, bone screws 300 are inserted using bone screw driver 416. To facilitate access for bone screw driver 416, expansion driver 414 may be withdrawn from insertion tool 410. After bone screws 300 are inserted, they can be blocked from backing out using blocking element 120. Lagging of the vertebral bodies can be performed before or after the bone screws are locked. Fluoroscopy or other imaging can be used to confirm final placement. Imaging can also be used at any of the steps to confirm work performed. Further, bone screw hole preparation and bone screw 300 insertion can be carried out prior to implant 100 expansion, to promote anchoring of the implant during expansion. In FIG. 18, an expanded implant 100 can be seen between vertebrae, secured by bone screws 300. The foregoing method provides a customized fit using implant 100, and minimizes disruption to patient anatomy.

[0099] Referring now to FIGS. 19-32, an alternative implant 100B of the disclosure has a shorter actuator screw 154B relative to actuator screw 154 of implant 100 of FIG. 1. Actuator screw 154B engages a proximal end of carriage 156B, and does not pass through graft portal 208B. A compact actuator frame 212 includes a screw bearing 210, and upper and lower tabs 214, 216, respectively. Endplate slots 218, 220 within endplates 110B and 112B slidably receive upper and lower tabs 214, 216. In this manner, actuator screw 154B is rotatably fixed along a longitudinal

axis with respect to endplates **110B** and **112B**, the longitudinal axis indicated in FIG. **19** to extend between distal (“D”) and proximal (“P”) ends. Endplates **110B**, **112B** can slide upon collar tabs **214**, **216** to mutually separate to form an expanded configuration of implant **100B**. Actuator screw **154B** can be rotatably retained within compact actuator frame **212**, so that carriage **156B** can be pushed or pulled in threaded engagement with actuator screw **154B**, without an axial displacement of actuator screw **154B**. This can be accomplished, for example, by a clip or other cooperative engagement between compact actuator frame **212** or bearing **210**, and actuator screw **154B**, or a blocking element (not shown) partially covering an end portion of actuator screw **154B**. In an embodiment, tabs **214** and **216** form a dovetail connection with endplate slots **218**, **220**.

[**0100**] It should be understood that implant **100** may identified with a suffix herein, for example **100B**, **100C**, **100D**, **100E**, to indicate embodiments illustrating various features of the disclosure. In consideration of the impracticality of illustrating and describing every possible permutation of features, it should be understood that, where logical, features of the various implants may be substituted among the implants. Thus, all of the implants may collectively be referred to as implant **100**, unless a specific reference is made to a feature illustrated by a particular embodiment.

[**0101**] Actuator screw **154B** threadably engages carriage **156B** at threads **160B**, whereby rotation of screw **154B** causes carriage **156B** to move towards or away from compact actuator frame **212**. Carriage **156B** has ramps **168**, **168A** and **170**, **170A**, which engage corresponding endplate ramps **164**, **164A**, **166**, **166A** as described with respect to implant **100**. As actuator screw **154B** is rotated, carriage **156B** translates with respect to endplates **110B**, **112B**. As a result, carriage ramps **168**, **168A** and **170**, **170A** slide against endplate ramps **164**, **164A**, **166**, **166A**, causing endplates **110B**, **112B** to mutually separate. In an embodiment, carriage **156B** is polymeric at threads **160B**, and an interference fit is formed between actuator screw **154B** and threads **160B**, whereby sufficient friction is created to resist unintended rotation of actuator screw **154B**, with a consequential change in height of implant **100B**.

[**0102**] Frame **152** slidably bears against frame support edges **224** extending along endplates **110B**, **112B**, and is slidably connected to carriage **156B** by carriage support screws **174**. In this manner, carriage **156B** is laterally supported, and inhibited from rotational movement, but may move longitudinally along a path defined by carriage support channel **176** and actuator screw **154B**. Additionally, channels or dovetail guides **200**, **202** in endplates **110B**, **112B** receive mating end portions **200A**, **202A** of carriage ramps **168**, **168A**, **170**, **170A**, to further guide and stabilize endplates **110B**, **112B**.

[**0103**] FIGS. **19-32** further illustrate an alternative blocking element **120B**, which, as with other of the various alternative elements herein, may be combined with other implant embodiments herein. Element **120B** forms a sliding block **226** within a block groove **228**, block **226** and block groove **228** forming a dovetail or other sliding mating engagement, wherein block **226** is confined to movement along a path defined by block groove **228**. Once bone screw head **302** is fully seated within bone screw socket **118**, block **226** may be slid partially out of engagement with block groove **228** to a position over bone screw head **302**, thereby

blocking a movement of bone screw **300** out of engagement with body tissue. In the embodiment shown, two blocking elements **120B** are illustrated, wherein a tool having two end portions (not shown) can be inserted adjacent each block **226**, and the tool rotated to move both blocks into a blocking position. Accordingly, blocks **226** together form substantially concentric arcs pivoting about the same or close axes.

[**0104**] Implant **100B** is configured to facilitate the insertion of graft material or other therapeutic material through one or more of bone screw socket **118** into graft chamber **204** formed by openings within endplates **110B**, **112B**, and carriage **156B**. After the material is inserted, bone screws **300** may then be inserted into socket **118** and fastened to body tissue as otherwise shown and described herein. A bone funnel **440** (FIG. **40**) may be used to urge material into graft chamber **204**. Alternatively, once implant **100B** is expanded, materials may be inserted into an endplate gap **230** formed by a separation of endplates **110B**, **112B**, as may best be seen in FIGS. **30** and **32**, which are cross-sections taken through compact actuator frame **212**, and upper and lower tabs **214**, **216**.

[**0105**] It should be understood that endplates of the disclosure, in all embodiments, may be formed of a unitary material, as illustrated in FIGS. **19-32** for example, or multiple materials, as illustrated in FIGS. **1-6** for example. Accordingly, endplates **110B**, **112B** may be formed of multiple materials, for example titanium for a proximal, bone screw engaging portion, and UHMWPE for a distal, bone engaging portion. Further, endplates **110B**, **112B** may be provided with teeth or other projections, to positively engage body tissue and reduce a likelihood of undesired migration of implant **100B**.

[**0106**] With reference to FIGS. **33-40**, a spacer implant **100C** includes frame **152C** which forms a dovetail engagement with upper and lower endplates **110C**, **112C**. In this manner, endplates **110C**, **112C** are further stabilized throughout a range of expansion of implant **100C**. As may be seen in FIG. **36**, a cross section of endplate portion **124C** illustrates frame support channel **232** of endplate portion **124C** is shaped to slidably retain frame extension guide **234** of frame **152C** (also visible in FIGS. **44-45**). It should be understood that an inverse configuration can be created, wherein a channel is formed in frame **152C** and an extension is formed from endplate portion **124C**. Similar channels and extensions can be formed on opposing sides of frame **152C**, as illustrated, with a frame support channel **232** formed in lower endplate portion **124C**, as well. In an embodiment, frame **152C** can form an extended region **238** along all or part of the dovetail engagement area of frame support channel **232** and extension guide **234**. For example, frame **152C** can extend in superior and inferior directions to extend from near an outer surface of endplate **110C** to near an outer surface of endplate **112C**, or may extend over a lesser distance. Channel **232** and extension guide **234** are illustrated as transverse to an A-P or longitudinal axis of implant **100C**. In an alternative embodiment, channel **232** and guide **234** are disposed at a non-transverse angle with respect to the longitudinal axis.

[**0107**] With reference to FIGS. **35** and **37**, carriage **156C** includes a graft chamber portal **236**, providing access from a exterior to a proximal end of implant **100C** into graft chamber **204**, after implant **100C** is implanted within the body. Carriage **156C** includes two portals **236** specifically formed to admit the passage of graft or other therapeutic

materials, however one or more than two portals **236** can be provided. In the embodiment illustrated, graft chamber portals **236** are formed within a portion of carriage ramp **170**, although other portions of carriage **156C** may be shaped or opened in a like manner. A bone funnel **440** may be used to direct material through one or more of graft chamber portal **236**.

[**0108**] As can be seen in FIG. **35**, actuator screw **154C** includes actuator screw bearing **184C** and lateral screw bearings **240**, provided to promote smooth rotation of actuator screw **154C**. Bearing channels **242** within actuator screw **154C** can be provided to maintain an orientation of lateral screw bearings **240** within screw guide **246** of carriage **156C**. In an embodiment, an interference fit is formed between lateral screw bearings **240** and screw guide **246**, to prevent unintended rotation of actuator screw **154C**. To further stabilize carriage throughout at least a portion of its range of motion, stabilizing posts, screws, or pins **248** can be provided, connected to frame **152C**, for example within frame pin bore **250** by threads, adhesive, or an interference fit, and slideably engageable within pin bores **252** within carriage **156C**. Alternatively, pins **248** can be affixed to carriage **156C**, and can slide within frame pin bores **152C**. In an embodiment,

[**0109**] As can be seen in FIGS. **35** and **38-39**, one or more radiographic markers **254** are positioned within implant **100C**, for example within radiotransparent portions of implant **100C**, or any other radiotransparent portion of the various embodiments herein. For example, a radiographic marker can be positioned within polymeric endplate portion **122**, **122A**, so that an expanded or contracted position thereof may be positively ascertained using imaging. As may be seen in FIG. **39**, radiographic markers **254A**, **254B** are oriented to be aligned with an end of carriage ramps **168**, **168A**, which in this embodiment are radiopaque, only when implant **100C** is fully expanded. To indicate an extent of expansion, one or more radiopaque markers **254** can be positioned with respect to frame **152**, carriage **156**, or any other portion of implant **100** which does not move together with an endplate **110**, **112**, and which is radiopaque, or which is similarly configured with a radiopaque marker **254**.

[**0110**] FIG. **40** illustrates a bone funnel **440** useable with implants **100**, **100B**, **100C**, **100D**, **100E** (collectively, herein, **100**) of the invention. An output aperture is placed proximate an opening into an open area within implant **100**, for example graft chamber **204**. Bone graft material, and/or other therapeutic agents, are collected within including for example bone growth factors, antimicrobial agents, or other therapeutic is placed into widened input chamber **444**, and then pushed down pipe **446** with a driver, for example a rod (not shown). A pipe connector **448** can be provided, sized to correspond to graft chamber portal **236**. Driven bone graft material is passed into an interior of implant **100**, where it may have its intended therapeutic benefit upon contacting body tissue of at least one vertebra.

[**0111**] In an embodiment, carriage ramps **168**, **168A**, **170**, **170A** can have differing ramp angles and/or sizes, wherein endplate ramps **166**, **166A** have corresponding profiles and sizes. For example, if ramps **168**, **168A** are shorter than ramps **170**, **170A**, expansion will occur at a greater rate along a proximal side of implant **100**, and in this manner an angular orientation of the spine, for example lordosis, may be corrected. Similarly, ramps **170**, **170A** can be shorter than ramps **168**, **168A**. Alternatively, one side of ramp **168**, **168A**

can be shorter than another side of ramp **168**, **168A**, with a corresponding difference along ramps **170**, **170A**. In this manner, a sideways orientation of the spine, for example Scoliosis, may be corrected.

[**0112**] FIGS. **41-43** illustrate an alternative implant **100D** of the disclosure, which pivots proximate ends of endplates **110D**, **112D**, providing both axial translation, as indicated by arrows "A", and pivoting, as indicated by arrows "B". Axial translation is maintained using frame **152C**, together with frame extension guide **234** and frame support channel **232**, as described with respect to implant **100C**. However, an endplate pivot **256** is formed between endplate portions **122D** and **124D**, and between endplate portions **122D'** and **124D'**. FIG. **43** illustrates implant **100D** with frame **152C** removed, illustrating an endplate hinge **258** formed between endplate portions **122D** and **122D'**. Connected in this manner, endplate portions **122D** and **122D'** pivot about endplate hinge **258**, as well as endplate pivots **256**. Accordingly, a height of implant **100D** at a distal end of implant portions **122D** and **122D'** is held constant, while a proximate end of implant portions **122D** and **122D'** translates axially with endplate portions **124D** and **124D'** to increase a height of implant **100D**.

[**0113**] Implant **100D** can be inserted into the intervertebral disc space at a collapsed height, and then expanded into lordosis to restore sagittal balance and height loss in the disc space. Implant **100D** provides distraction as well as achieving optimal sagittal balance. Further, implant **100D** reduces impaction to body tissue during insertion at a collapsed height, and gives a medical practitioner the capability to continuously adjust the lordotic angle of the supporting endplates to best fit the patient's anatomy and therapeutic needs.

[**0114**] Endplate pivot **256** is formed as mating circular portions of endplate portions **122D** and **124D**, and of endplate portions **122D'** and **124D'**. While one endplate portion forms an extension, and the other a receptacle, it should be understood that this configuration may be reversed.

[**0115**] Endplate hinge **258** is formed as a flexible connector **260** extending between endplate portions **122D** and **122D'**. In an embodiment, endplate portions **122D** and **122D'** are molded as a single part from a polymeric or other flexible material, thus forming a living hinge. In a further embodiment, a hinge is formed between endplate portions **122D** and **122D'** by any known means, including a barrel or flag hinge, or a hinge similar in style to endplate pivots **256**. In an alternative embodiment, endplate hinge **258** is formed in connection with frame **152C**.

[**0116**] By providing both axial and pivoting movement of endplate portions, implant **100D** enables the formation of an alternative supporting structure, and in particular, a supporting structure with a convex conformity. This can be useful to correct particular spinal problems, including lordosis, for example.

[**0117**] With reference to FIGS. **44-45**, which are cross-sections of an alternative implant **100E** of the disclosure, it may be seen that actuator screw **154E** is rotatably connected to frame **152E**, for example using C-clip **262**, as illustrated. An alternative method of rotatably securing actuator screw to frame **152E** can include, for example, a leading set screw **178** (see, e.g. FIGS. **6**, **6A**) that freely spins relative to frame **152E**, but is affixed to actuator screw **154E**. An alternative method includes forming mating portions (not shown) upon frame **152E** and screw **154E**.

[0118] Further stability can be provided for carriage 156C through the use of stabilizing pins 248, frame pin bores 250, and pin bores in carriage 152C, as described with respect to implant 100C herein.

[0119] In a further embodiment, actuator screw 154E' is shorter than actuator screw 154E, and thereby reduces an obstruction of graft chamber 204. A tool can be passed through screw guide 246, and then through graft chamber 204, to engage actuator screw proximal end 182. Graft material can additionally be passed through screw guide 246, and placed within graft chamber 204. Bone funnel 140 can be used to pass materials through screw guide 246, and pipe connector can be adapted or replaced to best fit the dimensions of screw guide 246.

[0120] FIGS. 46-53 illustrate yet another embodiment according to the present invention. Specifically, an intervertebral implant 300 for positioning between adjacent vertebral bodies is illustrated.

[0121] The purpose of the implant 300 is to insert it into the intervertebral disc space at a collapsed height, and then expand it axially to restore height loss in the disc space. The implant 300 would provide distraction as well as achieving optimal height restoration. This invention solves the problems currently encountered that include excessive impaction during insertion and visual obstruction and over distraction using a ramped inserter.

[0122] Turning to FIG. 53, an exploded view of the features of the implant are illustrated. The implant 300 comprises primarily a first endplate 302, a second endplate 304, a body 306, an actuator 308, and an actuator screw 310. The actuator 308 is configured so that it may translate relative to a body 306 by means of the threaded actuator screw 310. However, it any other type of actuator mechanism may be used such as a ratcheting system. The actuator 308 may have a larger, single axial opening for graft material, or have webbing for additional strength. The actuator screw 310 is fastened to the body using a retention clip 312, set screw, or other similar mechanical devices. The actuator 308 is also configured with ramped surfaces 314 that mate with ramped features on the first and second endplates 302, 304.

[0123] In operation, as the actuator 308 is linear translated, the actuator 308 causes the endplates to move axially to expand the implant, as illustrated in FIGS. 49-52. The actuator 308 is provided with dovetail features which enable the actuator 308 to capture the first and second endplates 302, 304 when collapsing the implant 300. A bushing 316 is used between the threaded set screw 310 and body 306 to minimize friction during expansion. Stabilizer screws 318 or pins can be used to capture the assembly and provide additional stability by sliding through specific slots in the body 306 and threading into the actuator 308. Additional inserts or a square nut can also be used to provide additional friction on the set screw threads to prevent height loss under cyclic loading. Bores 320 on the front face of the implant are used for packing additional graft material into the graft chamber after expansion. It should be noted that an instrument such a holder may be configured to attach to these features, or attach to another part of the implant.

[0124] The first and second endplates are configured to cover the entire top surface as shown in FIG. 46 or a portion of it as shown in FIG. 47. The first and second endplates can have ridges or teeth to prevent post-operative cage migration. Radiopaque markers 322 can also be used to aid with

fluoroscopic visualization. The assembly may also be provided with ports that provide access into the center graft chamber which can be used to pack additional graft material.

[0125] The advantage of this device is that it allows continuous expansion and distraction over the range of that specific implant. This provides the ability to distract vertebral bodies to a desired height, but also collapse the device for repositioning if desired. This implant has the ability for the endplates to converge providing lordosis and through windows cut for bone graft placement.

[0126] All references cited herein are expressly incorporated by reference in their entirety. There are many different features to the present invention and it is contemplated that these features may be used together or separately. Unless mention was made above to the contrary, it should be noted that all of the accompanying drawings are not to scale. Thus, the invention should not be limited to any particular combination of features or to a particular application of the invention. Further, it should be understood that variations and modifications within the spirit and scope of the invention might occur to those skilled in the art to which the invention pertains. Accordingly, all expedient modifications readily attainable by one versed in the art from the disclosure set forth herein that are within the scope and spirit of the present invention are to be included as further embodiments of the present invention.

What is claimed is:

1. An implant comprising:
 - a frame;
 - an actuator extending through the frame;
 - a carriage received within the frame;
 - an upper endplate positioned above the frame, wherein the upper endplate includes at least one upper socket for receiving a bone screw therethrough; and
 - a lower endplate positioned below the frame, wherein the lower endplate includes at least one lower socket for receiving a bone screw therethrough,
 wherein rotation of the actuator causes the implant to move from an unexpanded configuration to an expanded configuration, wherein in the unexpanded configuration the upper endplate including the at least one upper socket is positioned a first distance away from the lower endplate including the at least one lower socket,
 - wherein in the expanded configuration the upper endplate including the at least one upper socket is positioned a second distance away from the lower endplate including the at least one lower socket, wherein the second distance is greater than the first distance.
2. The implant of claim 1, wherein the carriage slideable with respect to the frame.
3. The implant of claim 2, wherein the carriage includes at least one upper ramped surface and at least one lower ramped surface.
4. The implant of claim 3, wherein rotation of the actuator causes the at least one upper ramped surface to engage at least one ramp extending from the upper endplate and the at least one lower ramped surface to engage at least one ramp extending from the lower endplate, thereby causing the implant to move from the unexpanded configuration to the expanded configuration.
5. The implant of claim 1, wherein the upper endplate and the lower endplate are formed of metal.

6. The implant of claim 1, wherein the upper endplate includes one upper socket and the lower endplate includes two lower sockets.

7. The implant of claim 6, wherein a blocking element is associated with each socket for preventing a bone screw from backing out.

8. The implant of claim 7, wherein each of the blocking elements is rotatable.

9. An implant comprising:

a frame;

an actuator extending through the frame;

a carriage received within the frame, the carriage slideable with respect to the frame;

an upper endplate positioned above the frame, wherein the upper endplate includes at least one upper socket for receiving a bone screw therethrough; and

a lower endplate positioned below the frame, wherein the lower endplate includes at least one lower socket for receiving a bone screw therethrough,

wherein rotation of the actuator causes the implant to move from an unexpanded configuration to an expanded configuration, wherein in the unexpanded configuration the at least one upper socket is positioned a first distance away from the at least one lower socket, wherein in the expanded configuration the at least one upper socket is positioned a second distance away from the at least one lower socket, wherein the second distance is greater than the first distance.

10. The implant of claim 9, wherein the implant is sized and configured for insertion via an anterior approach.

11. The implant of claim 9, wherein the upper endplate and the lower endplate are non-parallel to one another.

12. The implant of claim 9, wherein the actuator extends through the carriage.

13. The implant of claim 12, wherein rotation of the actuator causes the carriage to translate.

14. The implant of claim 13, wherein translation of the carriage causes the upper endplate to move from the unexpanded configuration to the expanded configuration.

15. The implant of claim 9, wherein the lower endplate includes at least two lower sockets for receiving bone screws therethrough.

16. The implant of claim 15, further comprising a blocking fastener associated with each of the two lower sockets for preventing back out of bone screws.

17. A method of installing an implant comprising:

positioning an implant in an intervertebral space, the implant comprising:

a translatable carriage;

an actuator extending through the carriage;

an upper endplate positioned above the carriage, wherein the upper endplate includes at least one upper socket for receiving a bone screw there-through; and

a lower endplate positioned below the carriage, wherein the lower endplate includes at least one lower socket for receiving a bone screw there-through,

rotating the actuator to cause the implant to move from an unexpanded configuration to an expanded configuration, wherein in the unexpanded configuration the upper endplate including the at least one upper socket is positioned a first distance away from the lower endplate including the at least one lower socket, wherein in the expanded configuration the upper endplate including the at least one upper socket is positioned a second distance away from the lower endplate including the at least one lower socket, wherein the second distance is greater than the first distance;

installing a first screw in the upper socket such that the first screw engages an upper vertebra;

installing a second screw in the lower socket such that the second screw engages a lower vertebra; and

placing graft material at least between the upper endplate and the lower endplate.

18. The method of claim 17, wherein the actuator comprises a rotatable screw, wherein rotation of the actuator causes translation of the translatable carriage.

19. The method of claim 18, wherein translation of the carriage causes the implant to move from the unexpanded configuration to the expanded configuration.

20. The method of claim 17, wherein the upper endplate is formed of titanium and the lower endplate is formed of titanium.

* * * * *