



US011498628B2

(12) **United States Patent**
Reeder et al.

(10) **Patent No.:** **US 11,498,628 B2**
(45) **Date of Patent:** ***Nov. 15, 2022**

- (54) **DRAG REDUCING DEVICE**
- (71) Applicant: **Aero Industries, Inc.**, Indianapolis, IN (US)
- (72) Inventors: **Ryan A. Reeder**, Carmel, IN (US); **John Vogel**, Naples, FL (US); **James R. Tuerk**, Indianapolis, IN (US)
- (73) Assignee: **Aero Industries, Inc.**, Indianapolis, IN (US)
- (*) Notice: Subject to any disclaimer, the term of this patent is extended or adjusted under 35 U.S.C. 154(b) by 204 days.

This patent is subject to a terminal disclaimer.

(21) Appl. No.: **17/113,505**
(22) Filed: **Dec. 7, 2020**

(65) **Prior Publication Data**
US 2021/0086845 A1 Mar. 25, 2021

Related U.S. Application Data

(60) Continuation of application No. 16/279,200, filed on Feb. 19, 2019, now Pat. No. 10,864,948, which is a division of application No. 15/613,515, filed on Jun. 5, 2017, now Pat. No. 10,532,780, which is a division of application No. 14/498,027, filed on Sep. 26, 2014, now Pat. No. 9,682,734, which is a continuation of application No. 13/447,481, filed on Apr. 16, 2012, now Pat. No. 8,845,007.

(60) Provisional application No. 61/538,391, filed on Sep. 23, 2011.

(51) **Int. Cl.**
B62D 35/00 (2006.01)

(52) **U.S. Cl.**
CPC **B62D 35/001** (2013.01)

(58) **Field of Classification Search**
CPC B62D 35/001
USPC 296/180.1
See application file for complete search history.

(56) **References Cited**
U.S. PATENT DOCUMENTS

9,682,734 B2* 6/2017 Reeder B62D 35/001
2018/0290694 A1* 10/2018 Grosse B62D 35/007
* cited by examiner

Primary Examiner — D Glenn Dayoan
Assistant Examiner — Dana D Ivey
(74) *Attorney, Agent, or Firm* — Maginot, Moore & Beck LLP

(57) **ABSTRACT**

A drag reducing device includes an air flow turning component having a curved surface adapted to turn air flow passing over the curved surface, a first mounting component for connecting the air flow turning component to a rear door of the vehicle, and a second mounting component for connecting the air flow turning component to one of the opposite side walls of the vehicle. The mounting components are configured so that the air flow component is automatically in a deployed position when the rear door is closed, so the air flow turning component turns air flow passing along the side the vehicle inward to thereby reduce drag. The mounting components are further configured so that the air flow component is automatically stowed between the rear door and the vehicle side wall when the door is fully opened. The air turning component is sized for a minimal prominence when stowed.

13 Claims, 17 Drawing Sheets

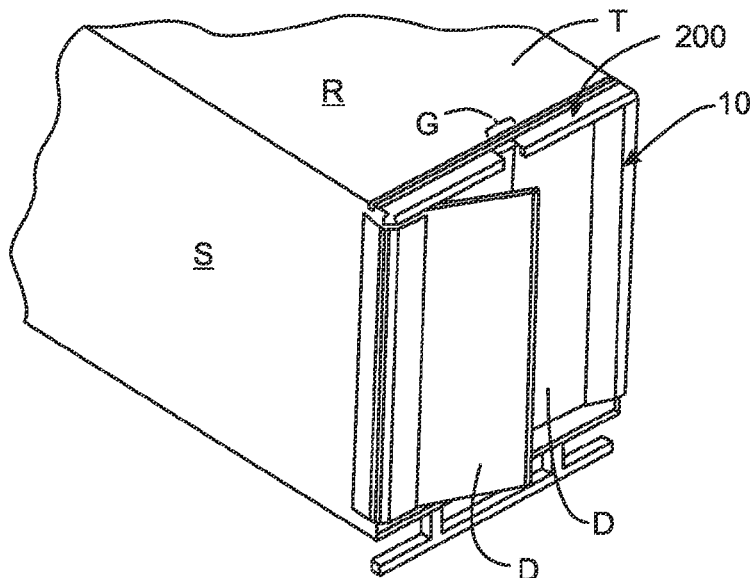

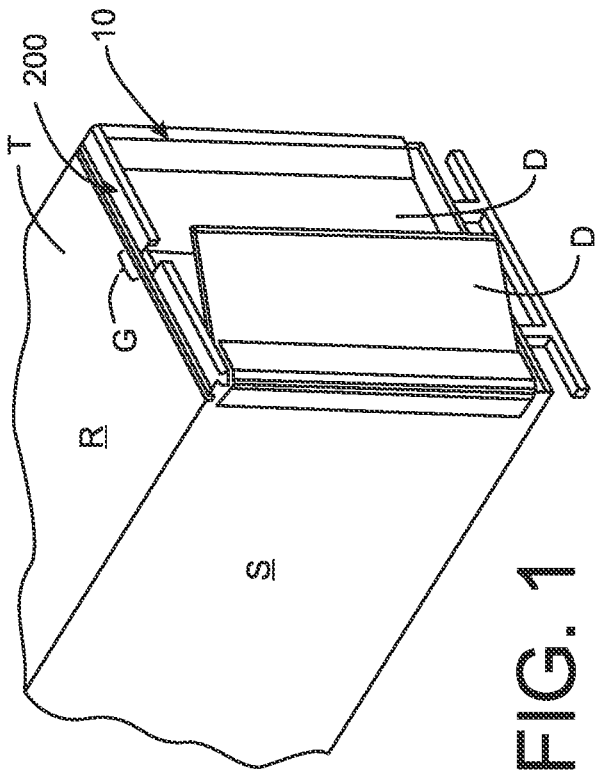

FIG. 1

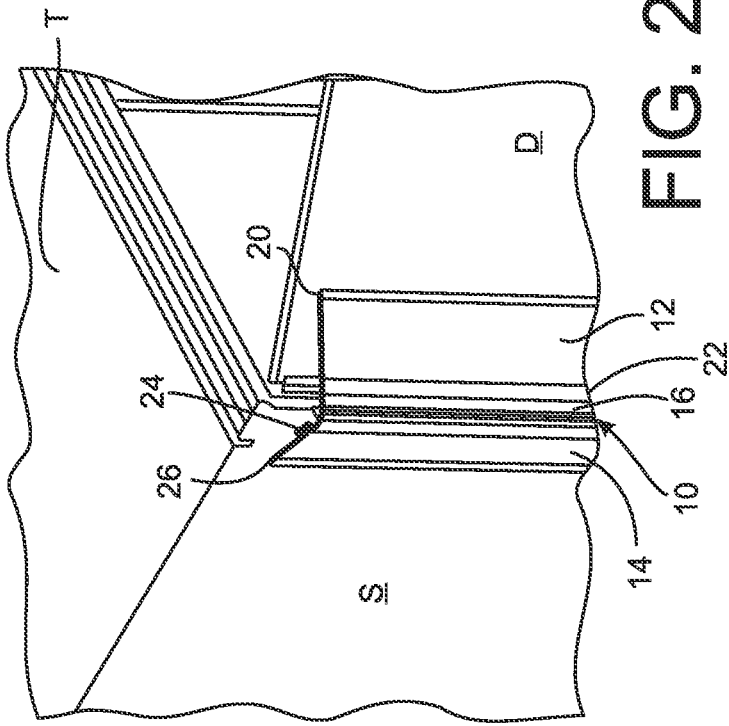

FIG. 2

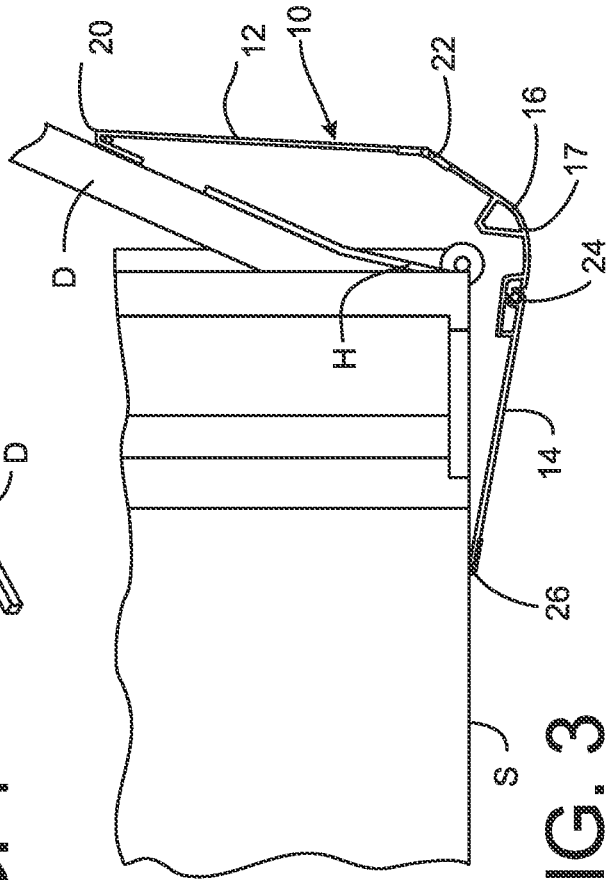

FIG. 3

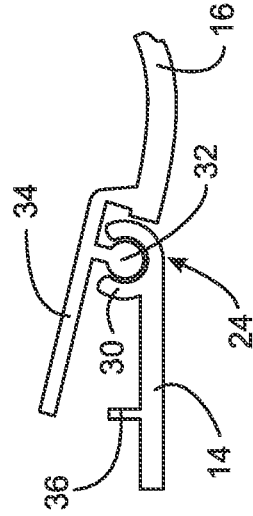

FIG. 4

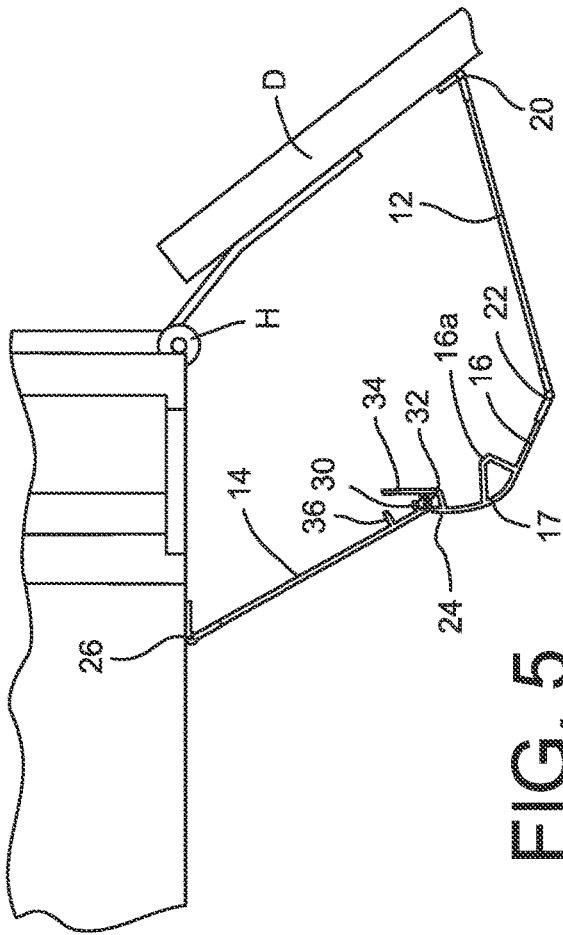

FIG. 5

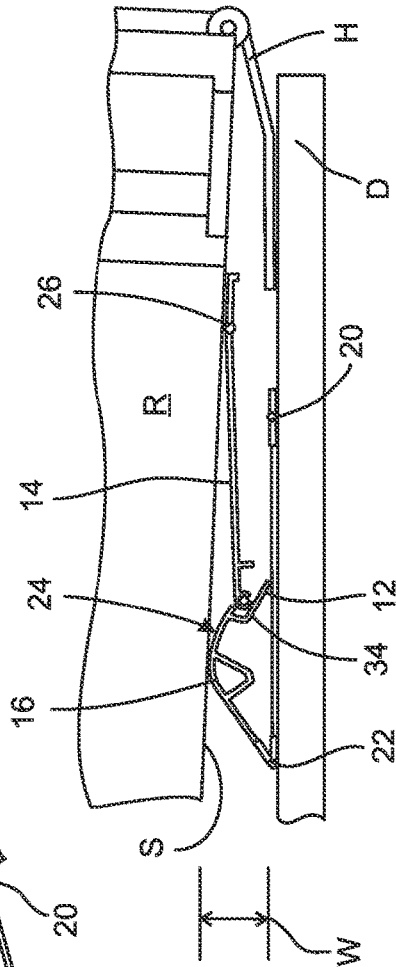

FIG. 6

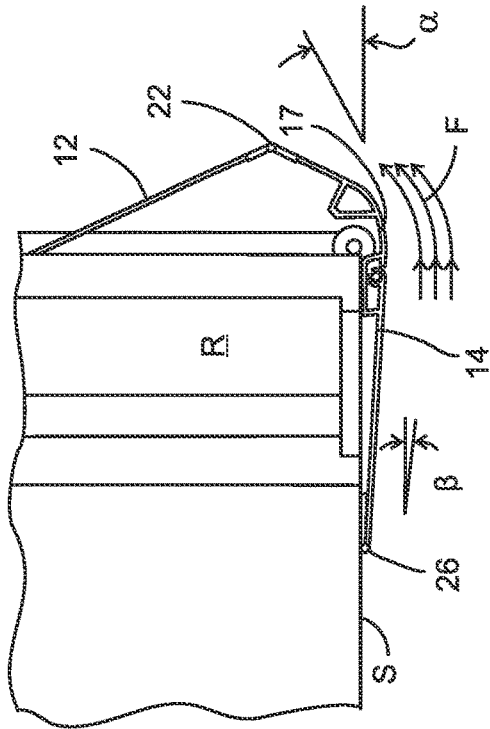

FIG. 7

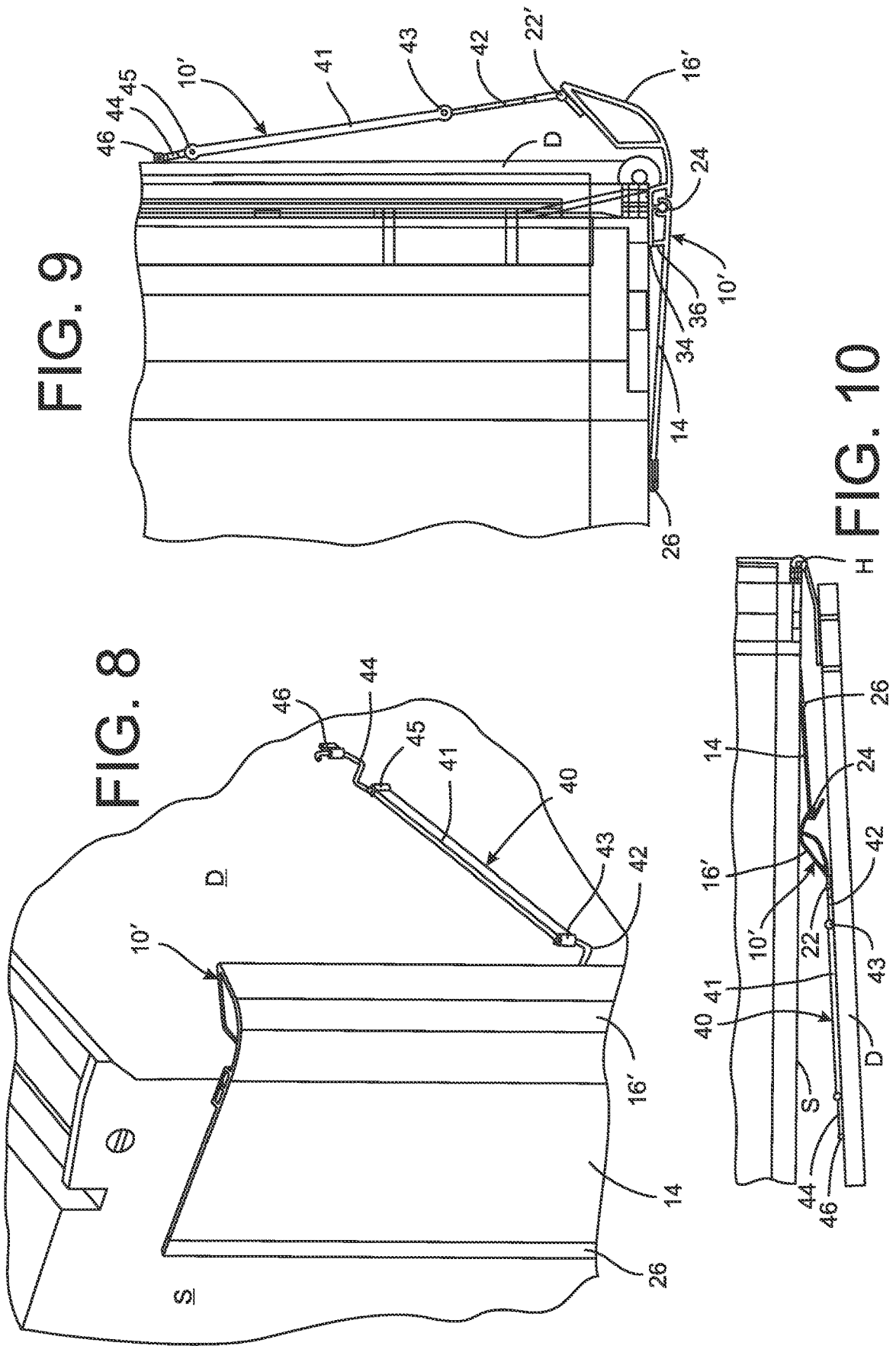

FIG. 9

FIG. 8

FIG. 10

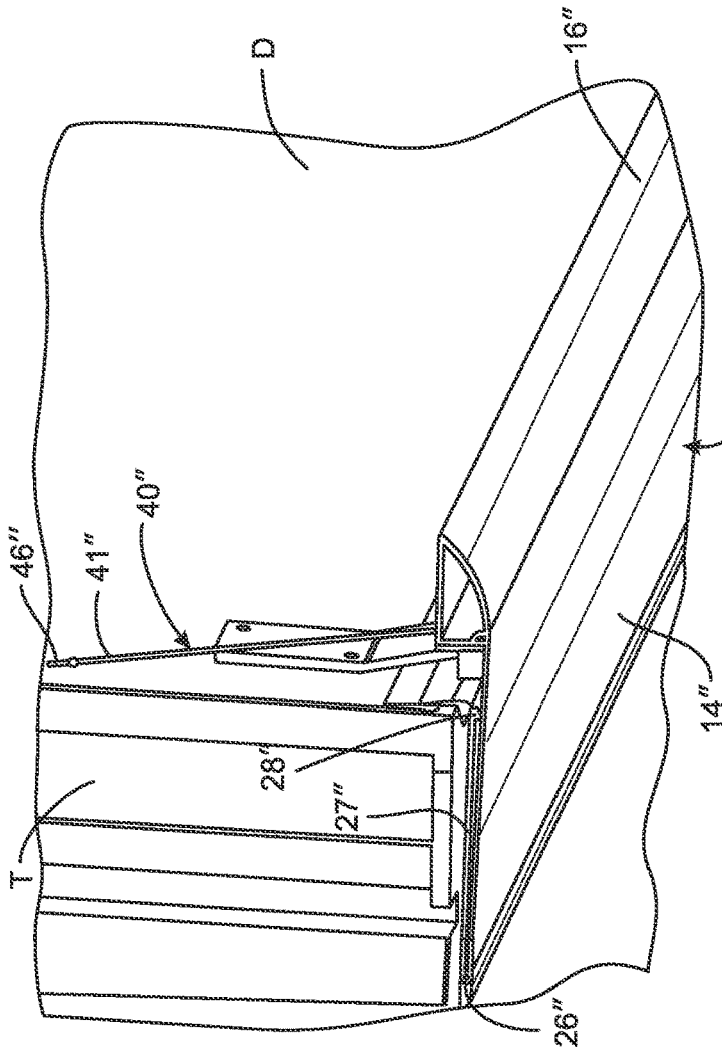

FIG. 11

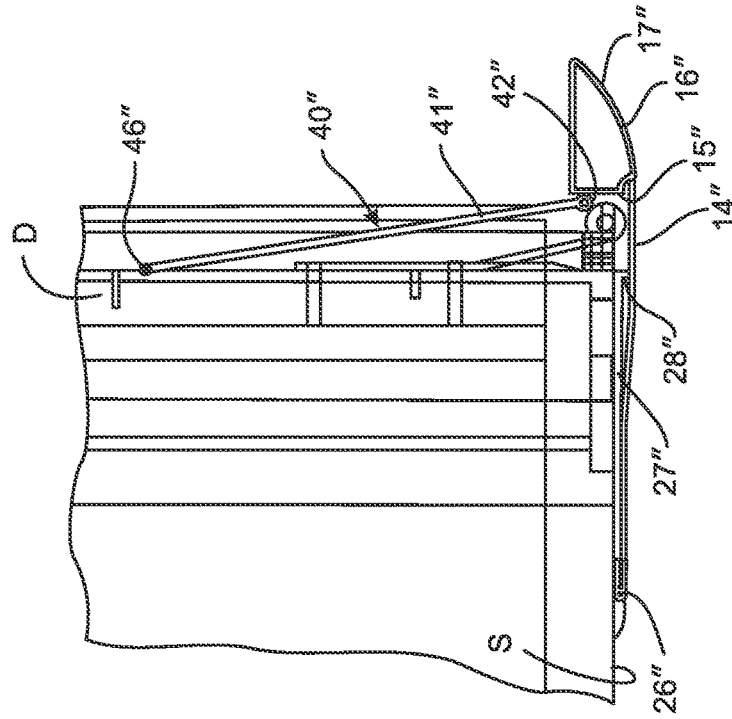

FIG. 12

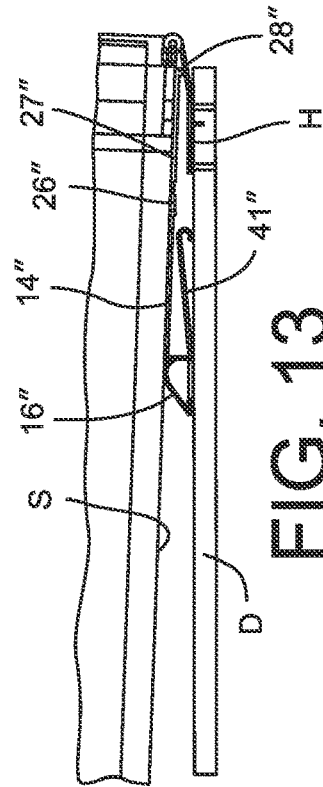

FIG. 13

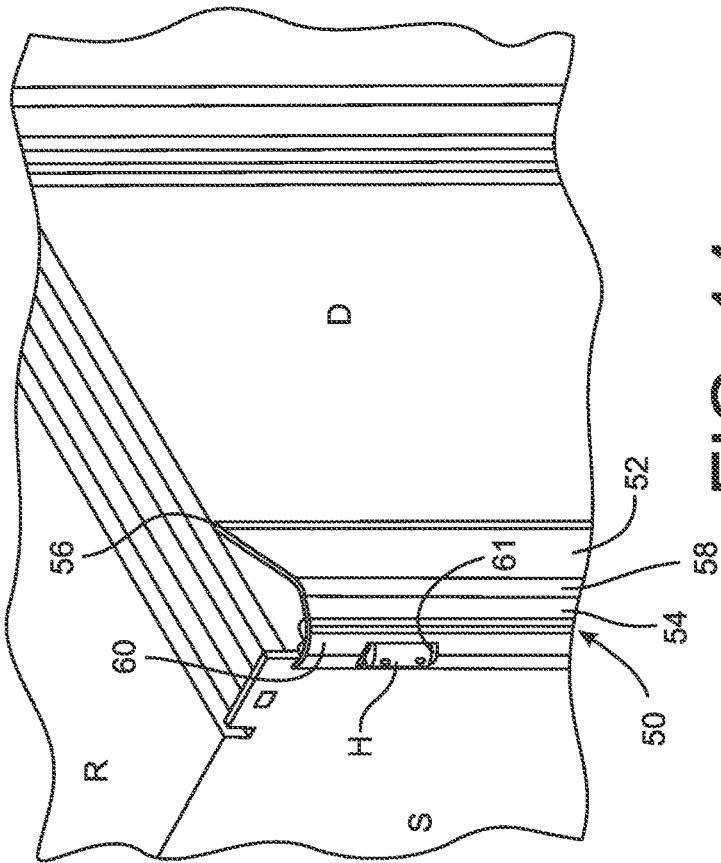

FIG. 14

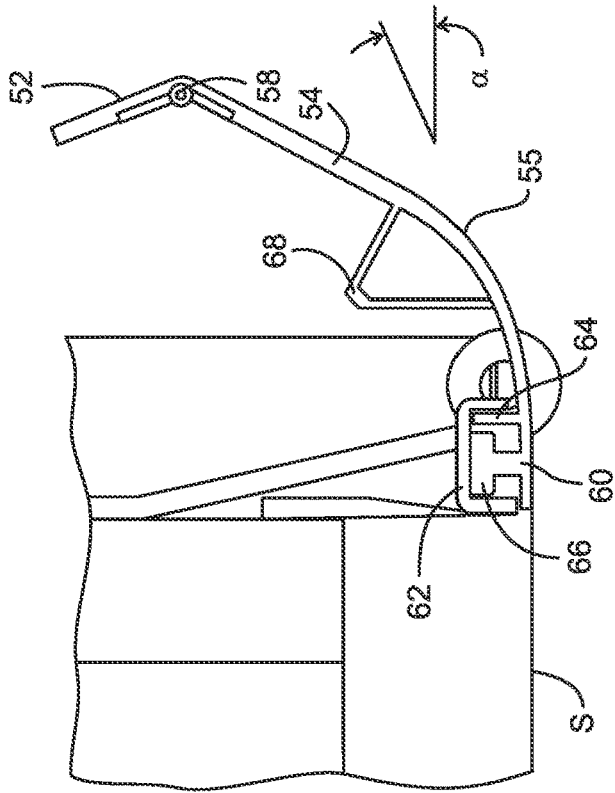

FIG. 15

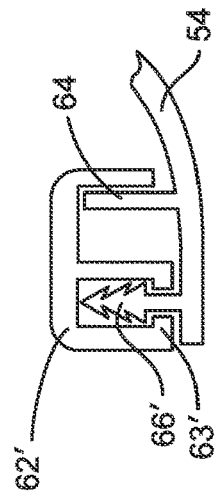

FIG. 16

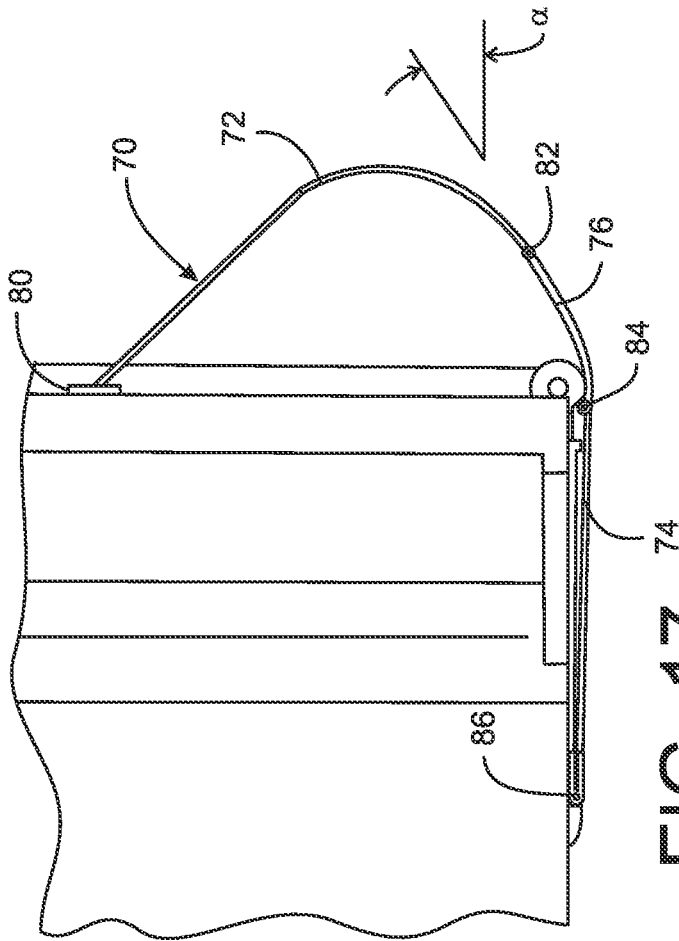

FIG. 17

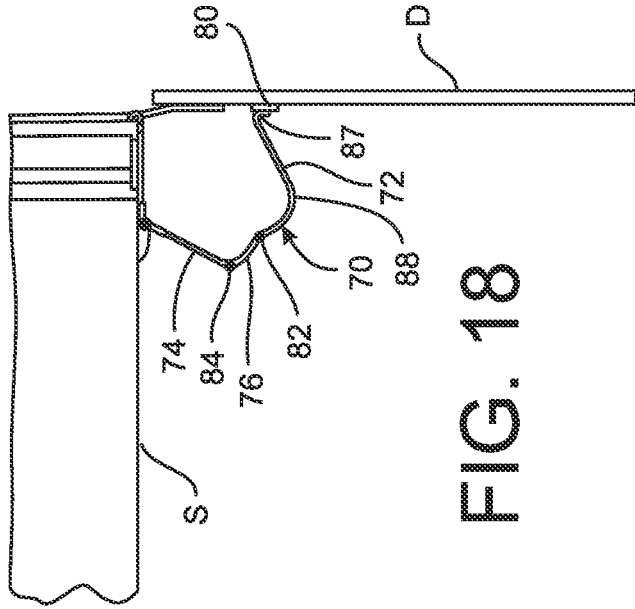

FIG. 18

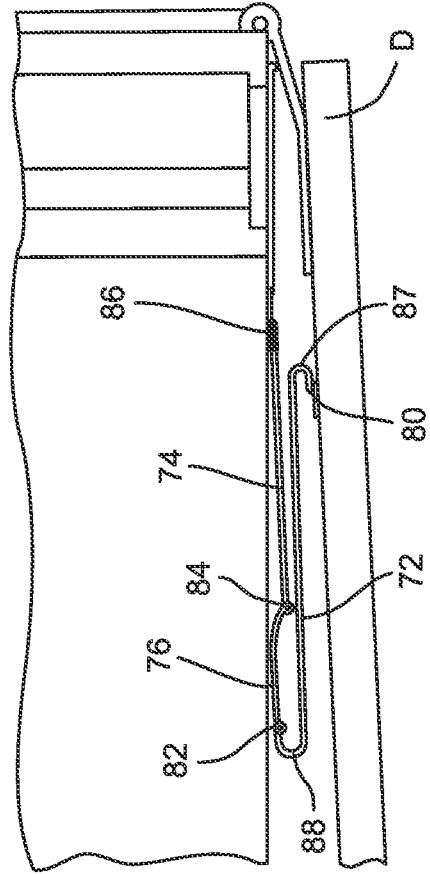

FIG. 19

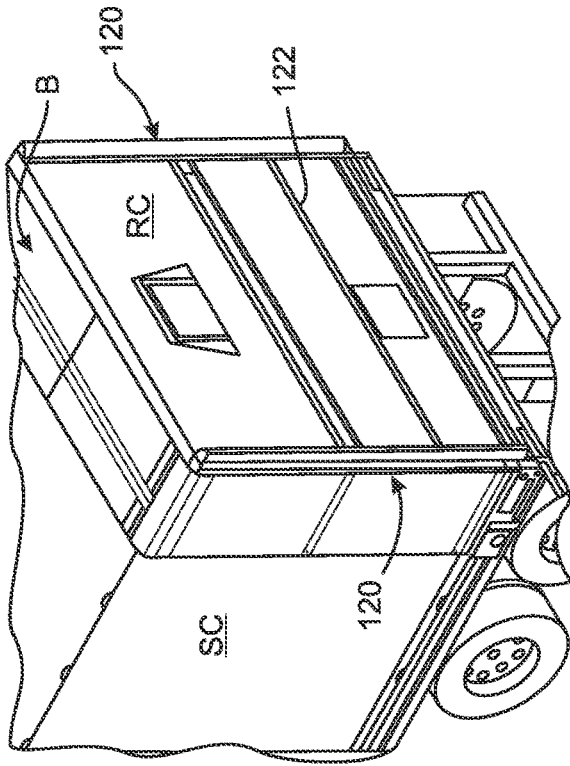

FIG. 20

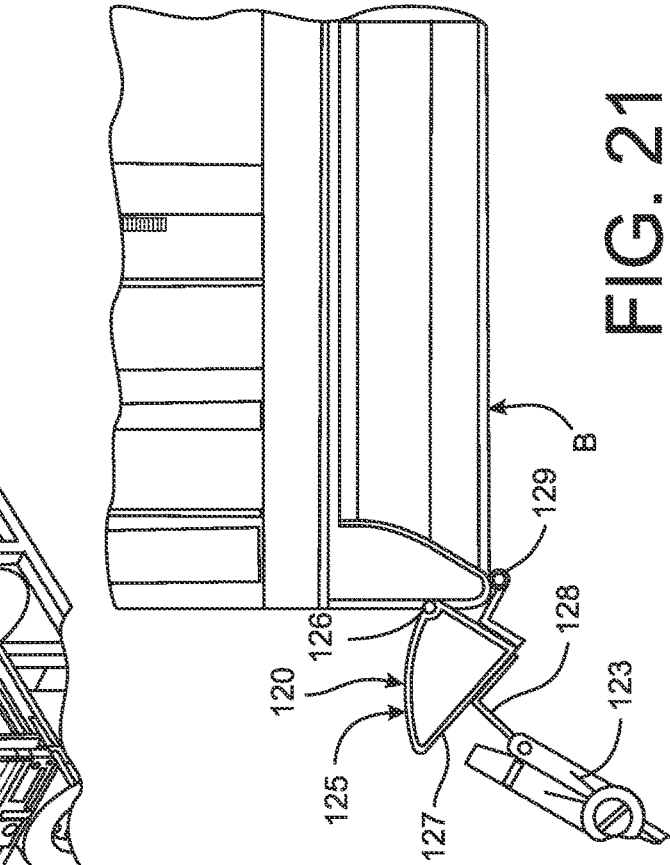

FIG. 21

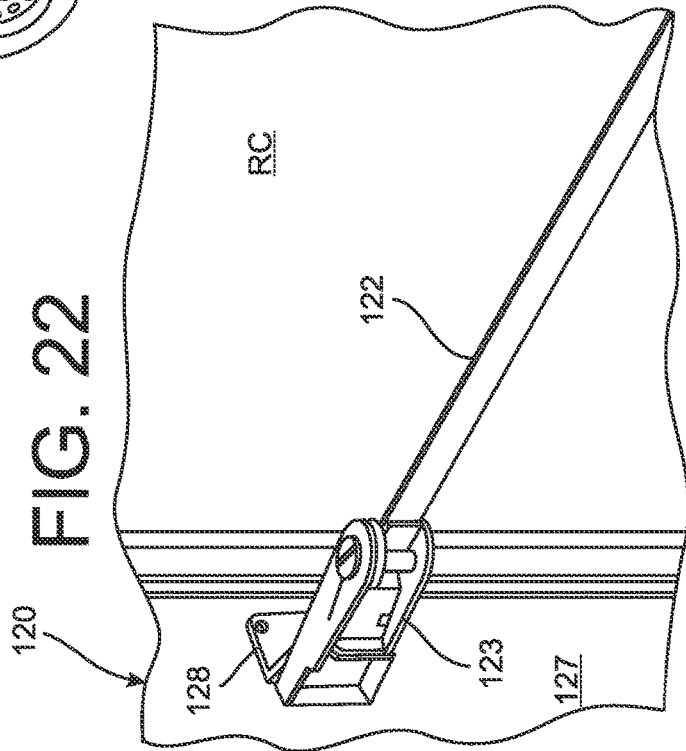

FIG. 22

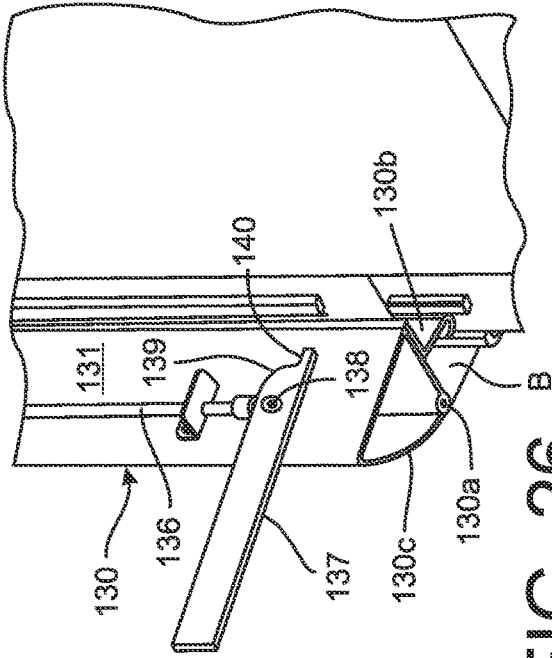

FIG. 24

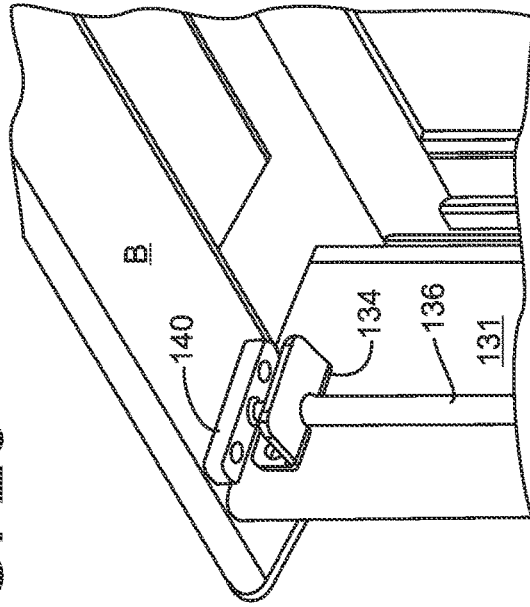

FIG. 25

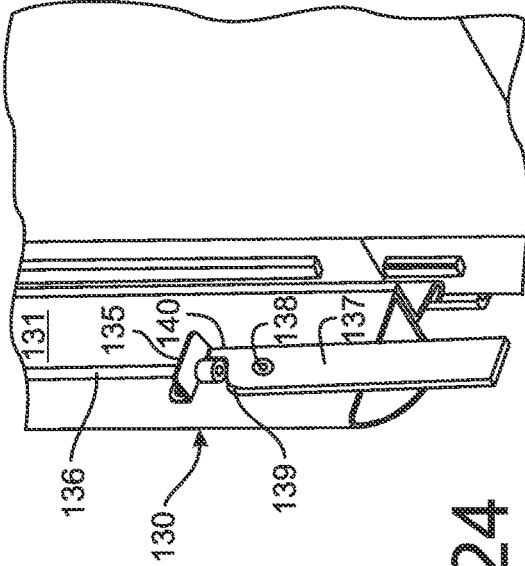

FIG. 26

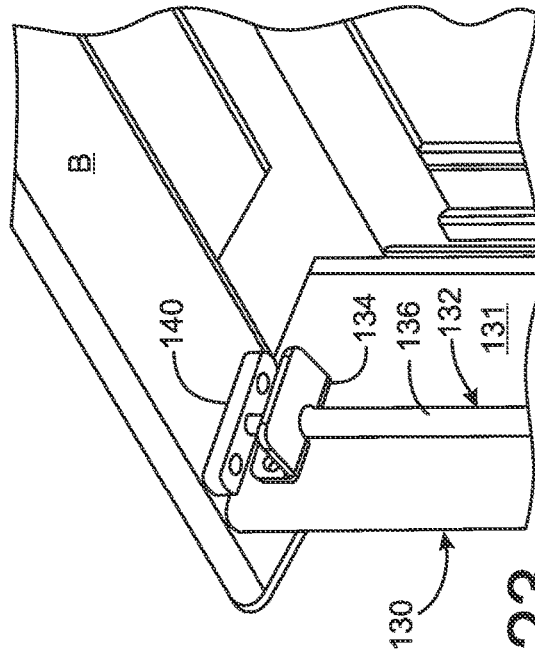

FIG. 27

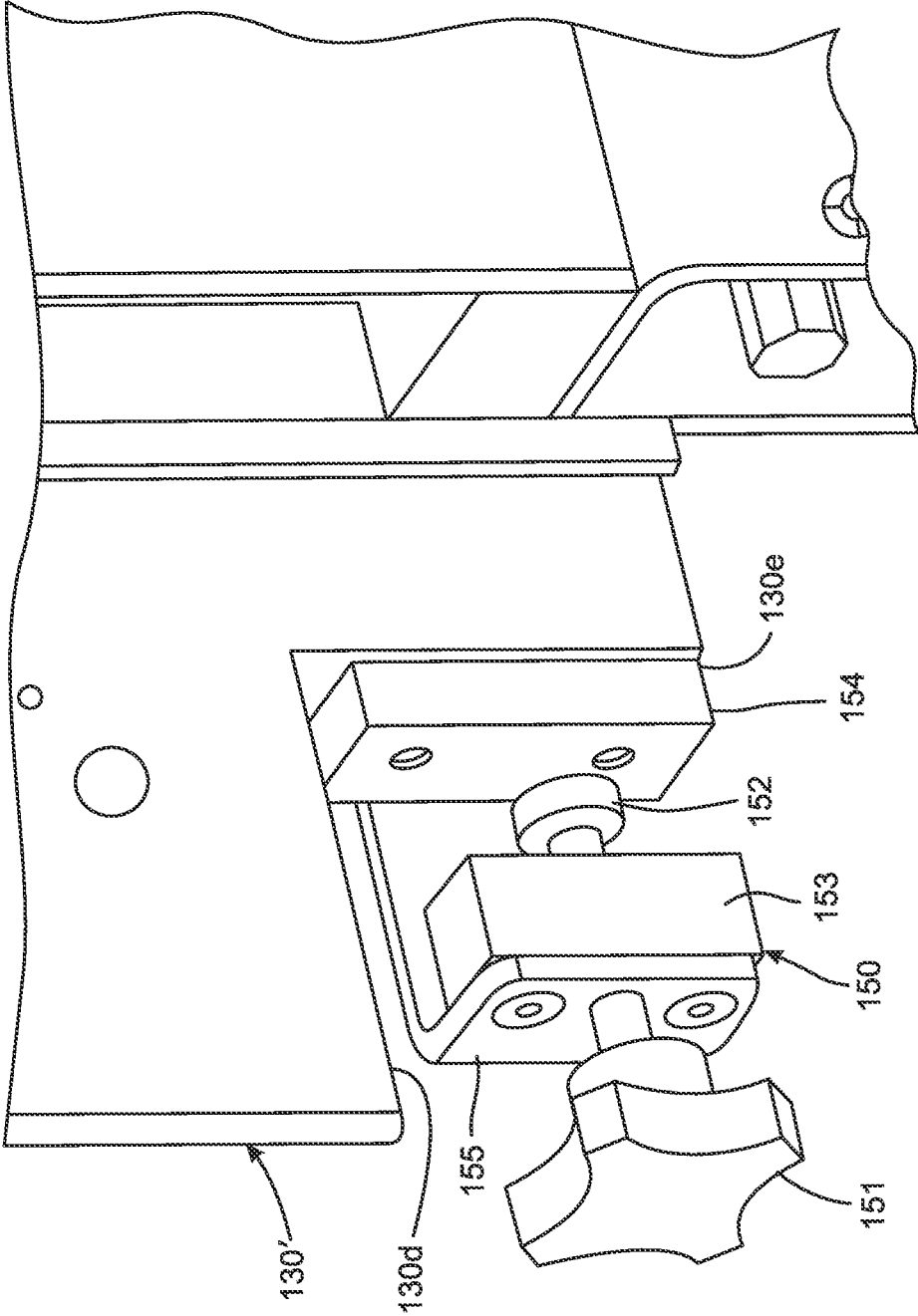

FIG. 27

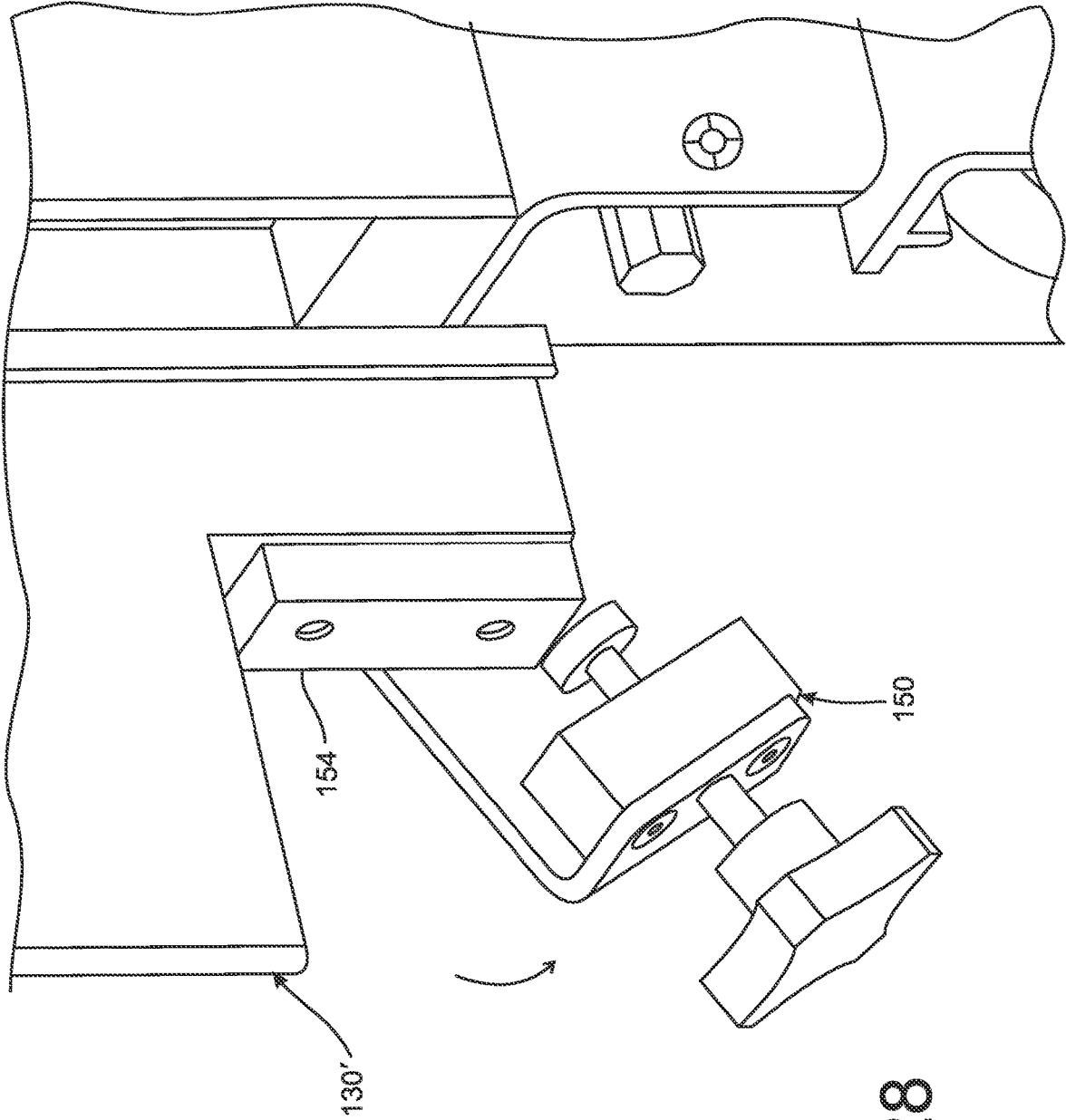

FIG. 28

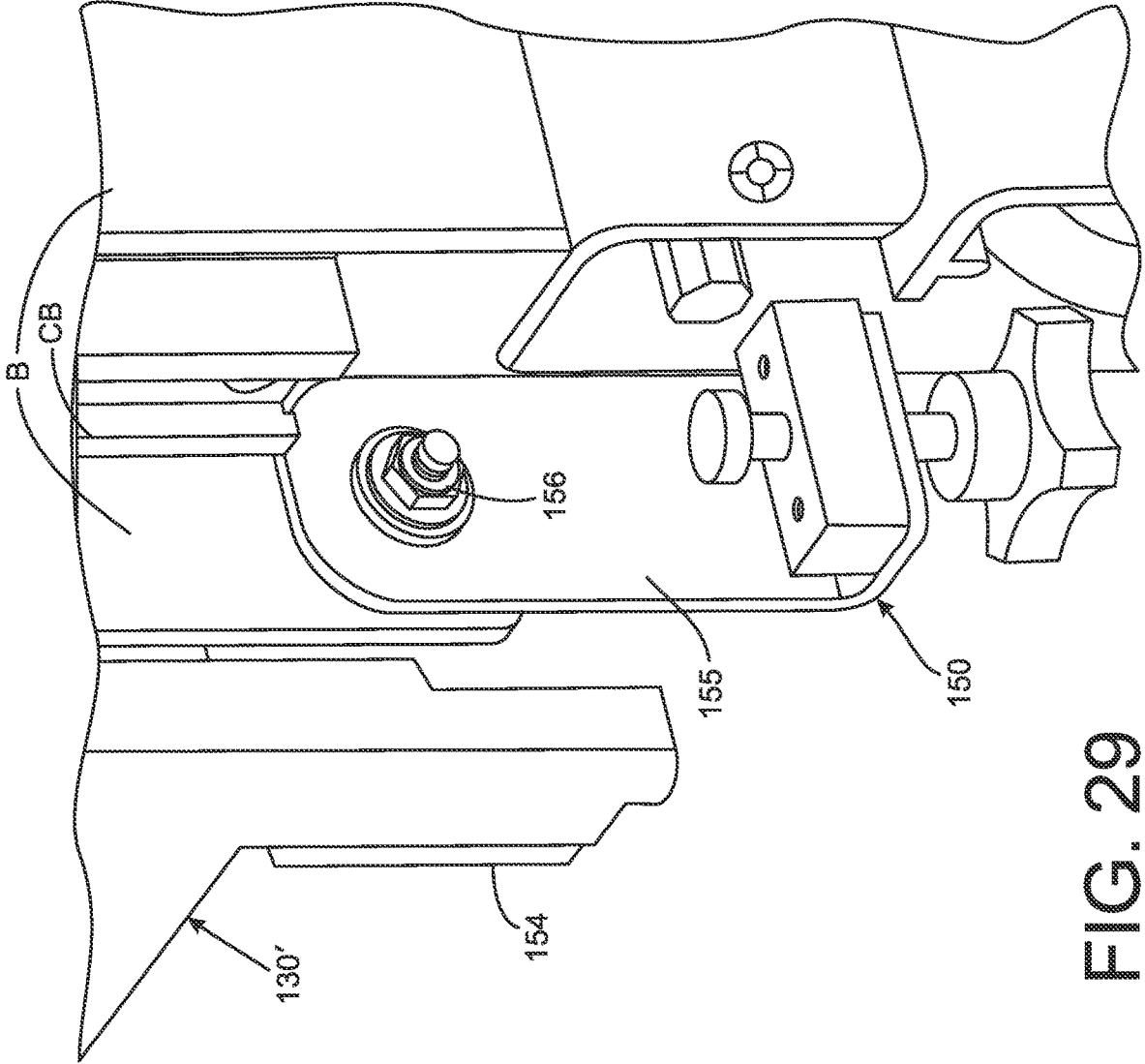

FIG. 29

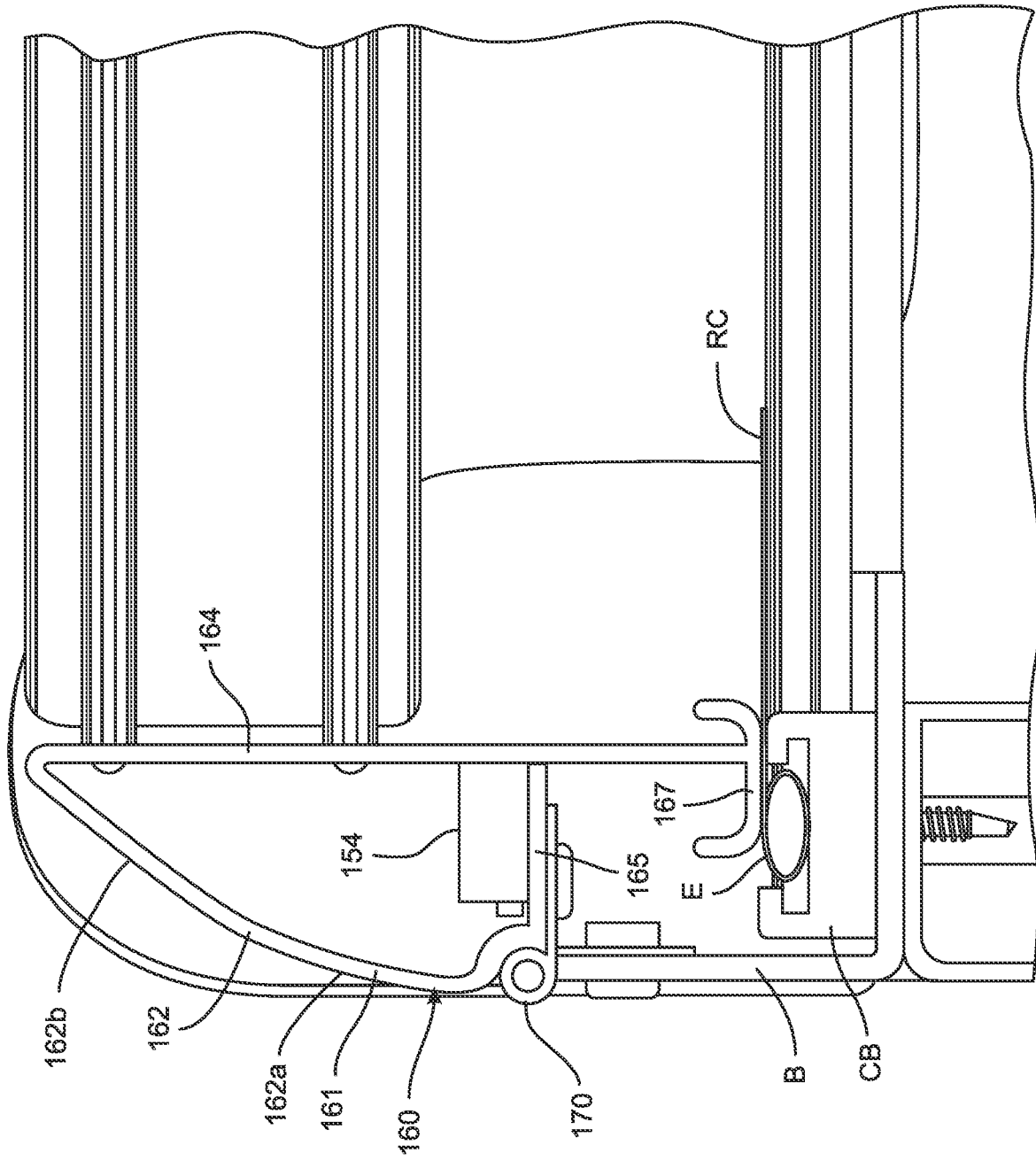

FIG. 30

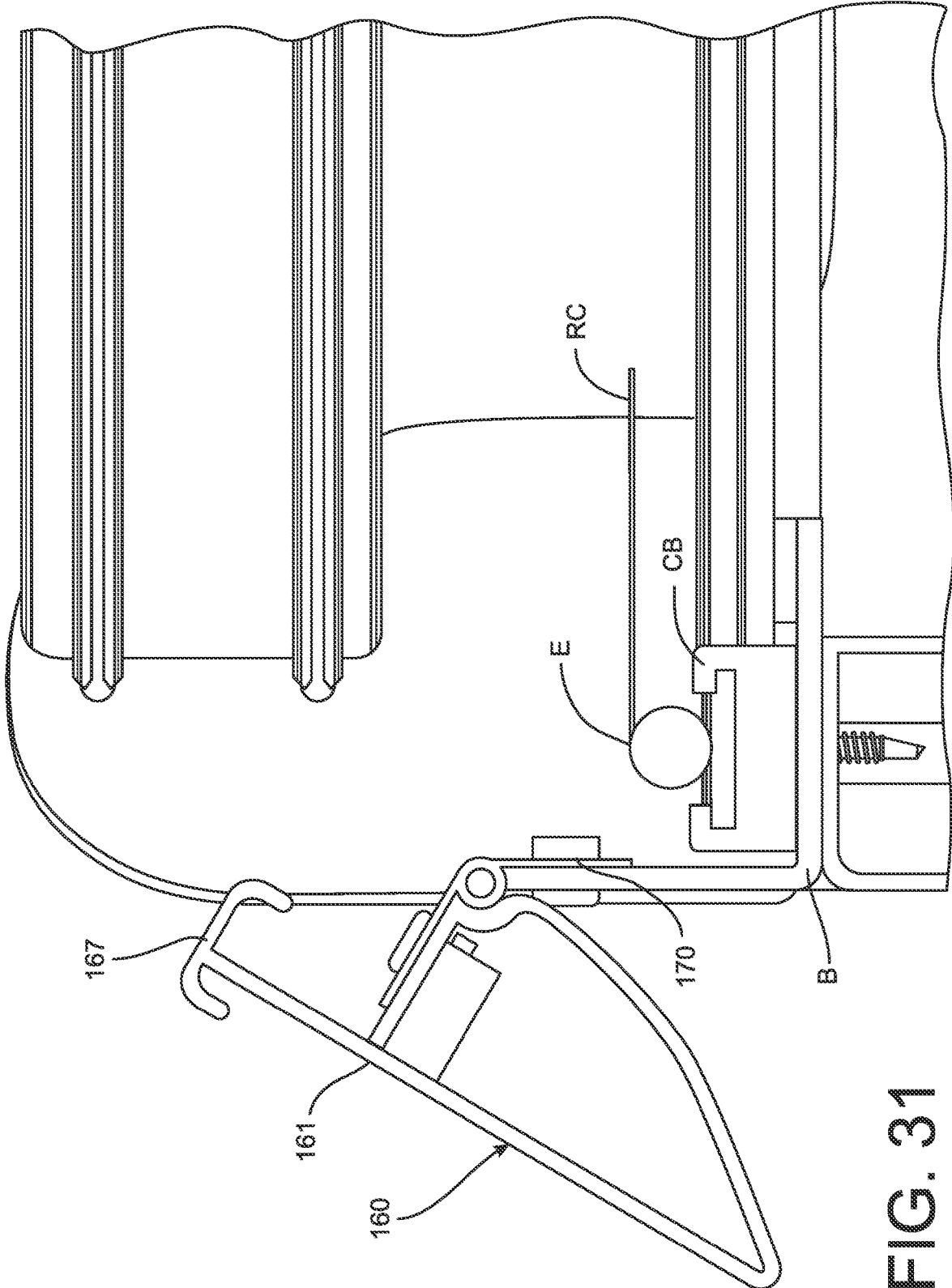

FIG. 31

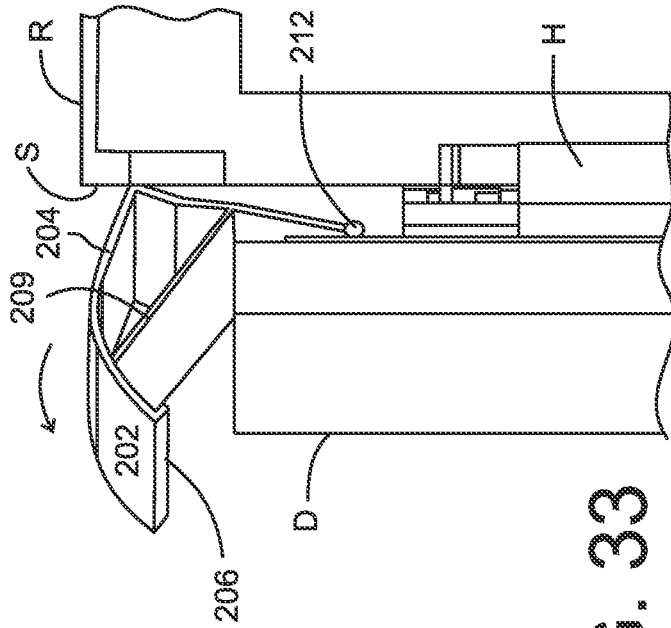

FIG. 33

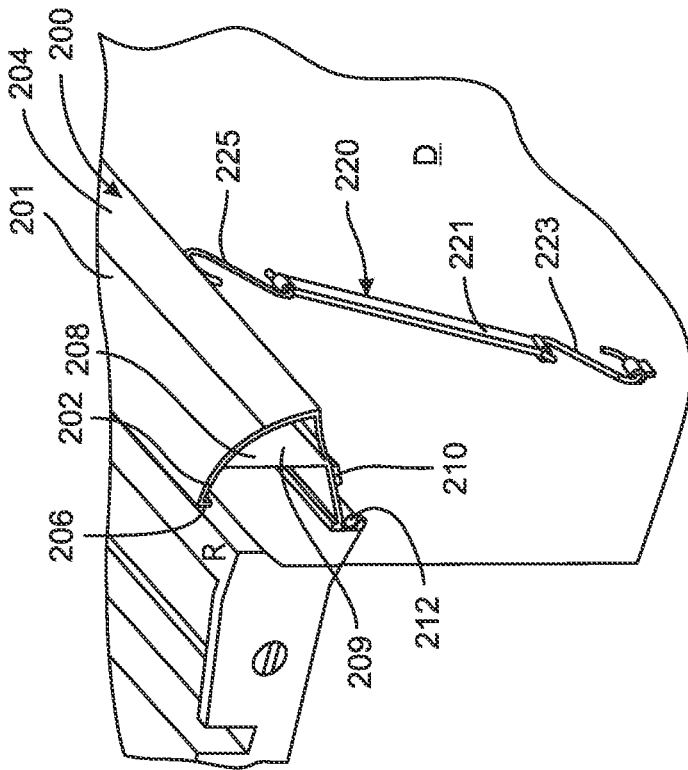

FIG. 32

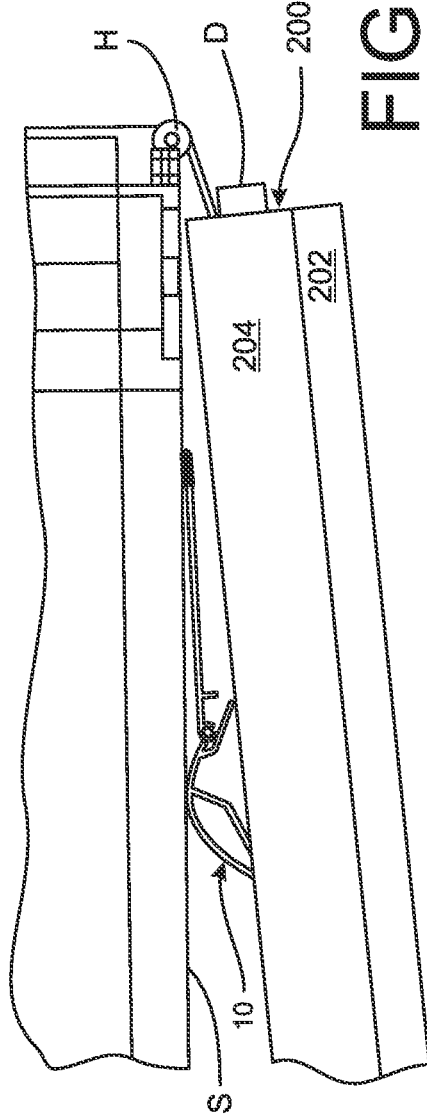

FIG. 34

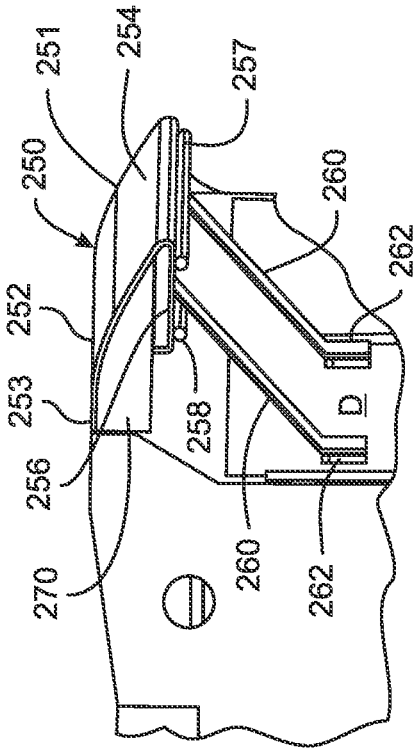

FIG. 36

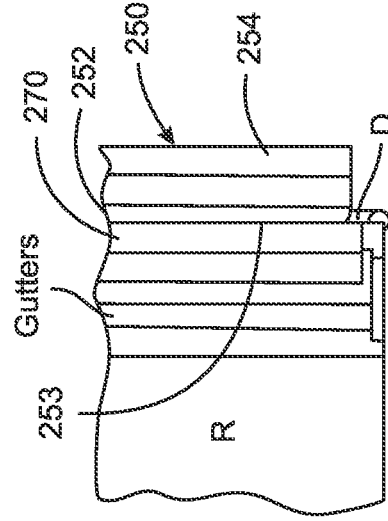

FIG. 37

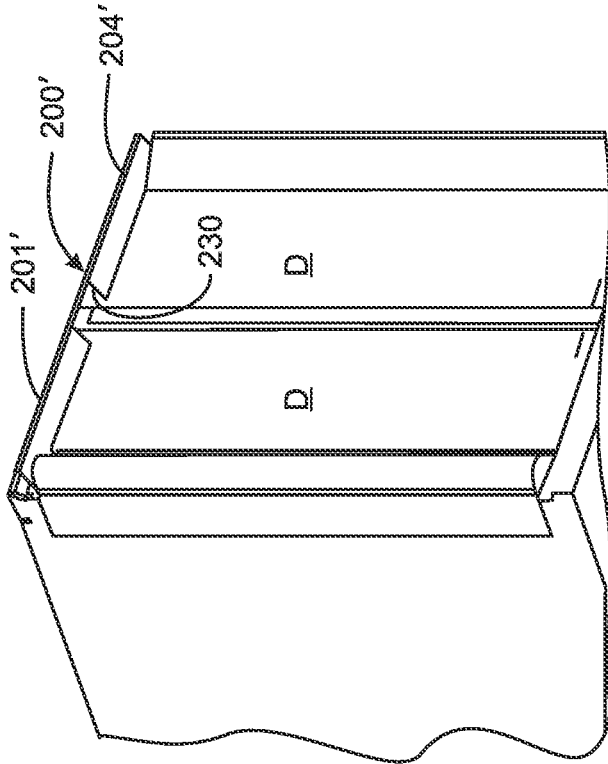

FIG. 35

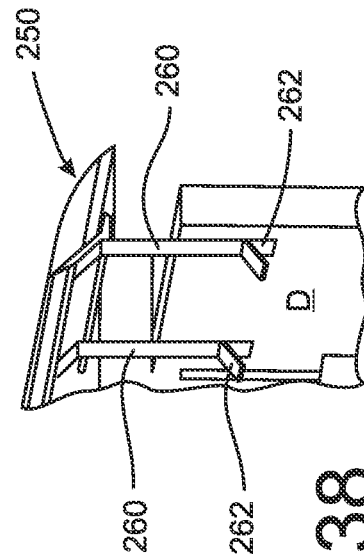

FIG. 38

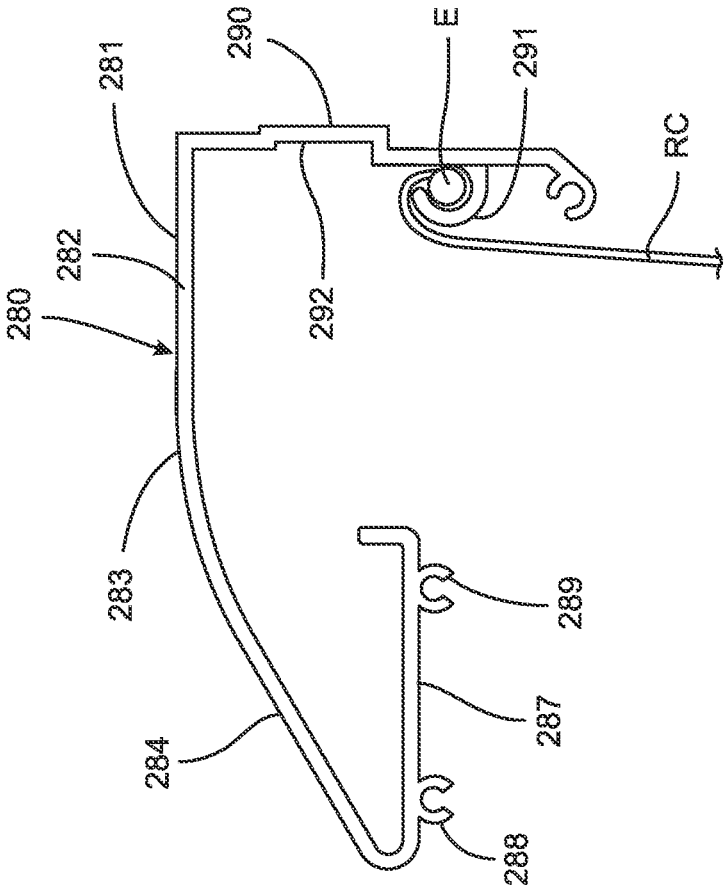

FIG. 39

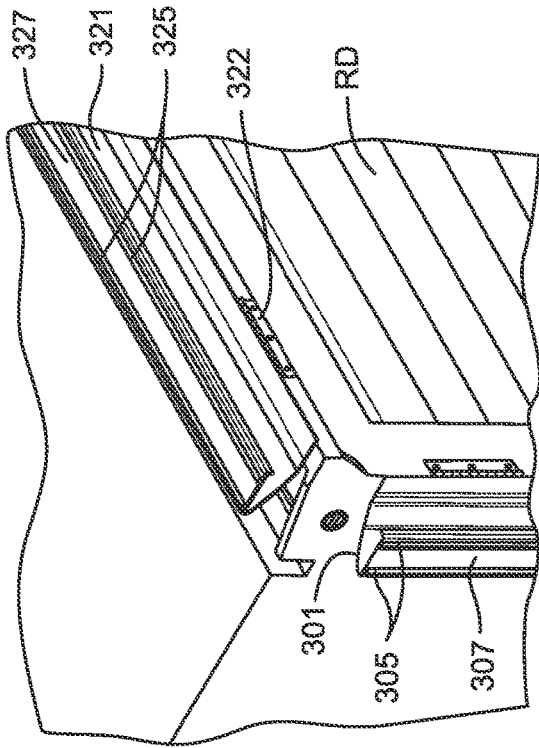

FIG. 41

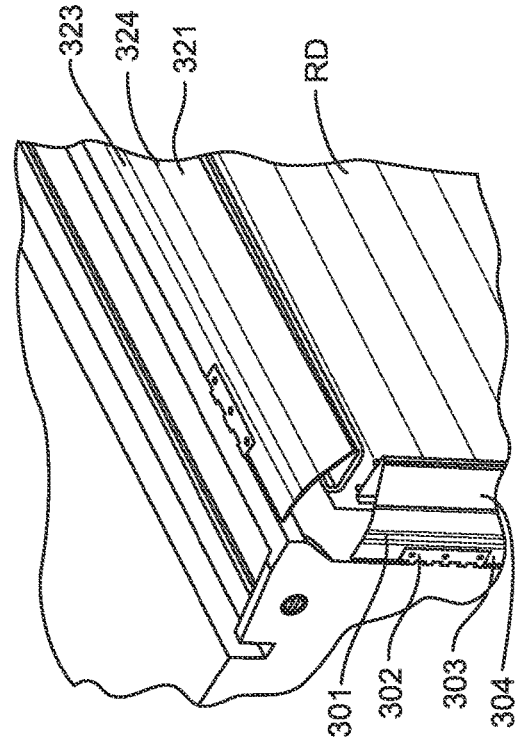

FIG. 42

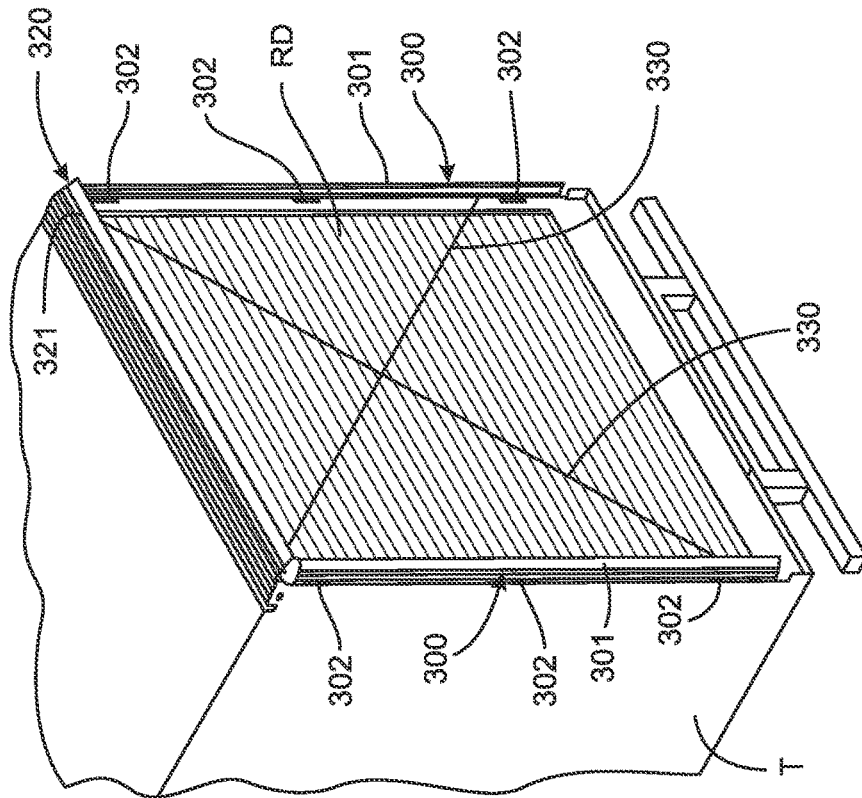

FIG. 40

DRAG REDUCING DEVICE

REFERENCE TO RELATED APPLICATION

The application claims priority to and is a continuation of application Ser. No. 16/279,200, filed on Feb. 19, 2019, and which issued as U.S. Pat. No. 10,864,948, on Dec. 15, 2020, which claims priority to and is a divisional application of Ser. No. 15/613,515, filed on Jun. 5, 2017, which claims priority to and is a divisional application of Ser. No. 14/498,027, filed on Sep. 26, 2014, which issued as U.S. Pat. No. 9,682,734, on Jun. 20, 2017, which is a continuation application of application Ser. No. 13/447,481, filed on Apr. 16, 2012, which issued as U.S. Pat. No. 8,845,007 on Sep. 30, 2014, and which is a utility conversion of provisional application Ser. No. 61/538,391, filed on Sep. 23, 2011, the entire disclosures of which are incorporated herein by reference.

BACKGROUND

The present disclosure relates to drag reduction devices for land vehicles, such as trucks, tractor-trailer rigs, vans, buses, recreational vehicles and similar vehicles having a large frontal area.

Fuel economy is a persistent concern for all land vehicles and is particularly acute for large vehicles such as trucks and tractor-trailer rigs. Fuel economy improvements have been achieved by innovation in engine design and improvements in fuel composition. However, the size and shape of the vehicles plays a substantial role in fuel economy. Ultimately, drag is the greatest enemy to fuel economy, with as much as 70% of the engine power devoted to cutting through the air in front of the vehicle.

Drag is a force that resists the movement of a body through a fluid, whether the body is a baseball and the fluid is air, or the body is a swimmer moving through water. Drag is a function of two components—friction drag and pressure drag. Friction drag is a force that acts tangential to a surface of the body. Friction drag is increased by irregularities or roughness on the surface and decreased by making the surface more slippery. A clean truck cuts through the air more efficiently and with less friction drag than a dirty truck.

Pressure drag is a force that acts perpendicular to a surface and is a function of the surface area in the direction of travel as well as the velocity or speed at which the body is traveling. Pressure drag increases as the square of velocity so that doubling vehicle speed actually creates four times more pressure drag. On the other hand, pressure drag is directly related to surface area so that a ten percent reduction in surface area leads to a ten percent decrease in pressure drag.

For aerodynamically configured vehicles, such as airplanes, friction drag contributes more heavily to overall drag than pressure drag. However, for land vehicles this relationship is reversed significantly. For a typical tractor-trailer, pressure drag can be as much as ten times greater than friction drag due to the large frontal surface area of the truck. Unfortunately, the size of these types of vehicles is dictated by their function—hauling products or materials. Unlike passenger vehicles, the box-like shape of trucks cannot be significantly altered. A smaller frontal surface area means a smaller truck, which means less cargo that can be hauled. Pressure drag in land vehicles, and especially in trucks, is increased by pressure “hot spots”, such beneath the undercarriage, behind the rear of the trailer or between the tractor and the trailer. These hot spots are generally regions of low

pressure, which causes air flowing over the vehicle to deviate from a streamlined path around the vehicle. Vortices can form in these hot spots that significantly increase the pressure drag.

In quantitative terms, if a square body has a drag coefficient (C_D) of 1.00, elongating the body into a rectangular shape reduces C_D to 0.80. Adding a rounded nose cuts the coefficient in half to 0.40. Adding a “boat tail” or a conical tail decreases C_D further to 0.20. The typical boattail configuration includes plates projecting from the rear of the vehicle and angled inwardly at an angle of 10-15°. An elliptical body tapered at both ends produces a drag coefficient less than 0.05, but the shape significantly reduces available cargo space and is difficult to produce.

It has been estimated that a 20% reduction in drag yields at least a 10% increase in fuel economy at highway speeds. For truckers and trucking companies, this increase in fuel economy means significantly reduced fuel costs year in and year out. For the environment, increases in fuel economy mean fewer deleterious emissions. A significant amount of effort has been expended in developing drag reduction technology for trucks. These efforts include streamlining the tractor, introducing seals, air deflectors or vortex generators in the gap between the tractor and trailer, and adding undercarriage skirts, guide vanes, air deflectors and boat tails to the trailer. Each of these modifications contributes in some measure to the overall drag reduction, so a fully optimized rig will incorporate a number of these improvements.

Presently, the typical drag reduction device utilizes “mechanical” redirection of the air flow to reduce drag. For instance, one type of device utilizes spoilers or fairings mounted to the top trailing edge of a vehicle or trailer to redirect the airflow and attempt to reduce turbulence. Another drag reduction device is the boat tail device that includes boat tail plates extending rearward from the rear of the trailer. Boat tail devices can reduce drag by up to ten percent. The typical boat tail is a large shell that is mounted over the rear doors of the trailer. Such devices are cumbersome to install and remove. Moreover, the large unitary shell is difficult to store when access to the rear doors is desired, such as to unload the trailer.

Other “mechanical” drag reduction devices require intervention by the vehicle operator to deploy and stow the device, while still other mechanical approaches require the vehicle operator to manipulate the drag reduction device to access the rear doors of the vehicle or trailer. Some mechanical devices are mounted directly to the vehicle/trailer doors which can eliminate the need to manipulate the device in order to access the trailer door. However, these devices are bulky and prevent the trailer/vehicle door from being fully opened flat against the side wall of the trailer/vehicle. This discrepancy can pose significant risks at shipping/receiving locations where trucks are backed in to closely spaced loading docks. A door that projects too far away from the side of the trailer can be struck by an adjacent vehicle as it attempts to back into an adjacent loading dock.

A more recent development in drag reduction are non-mechanical devices, meaning devices that do not mechanically turn or redirect the air flow, like a spoiler, but instead generate a force that acts on the air flow. One such device is a plasma flow actuator that provides a “body force” to the air flow as it passes over a surface to accelerate the air, thereby stabilizing the boundary layer and causing the air to remain “attached” or conform to the surface to reduce or eliminate flow separation, turbulence and, ultimately, drag. One type of plasma flow actuator is electronically controlled for

activation at appropriate vehicle speeds and for precise operation to optimize the drag reducing effect.

Whether the actuator is mechanical or non-mechanical, there is a persistent need for a drag reduction device that does not impede the ability to open the rear doors of a trailer or truck on which the device is mounted. Moreover, in order to ensure that the drag reduction device is consistently used, the device should be “automatic”, meaning that it does not require any intervention by the vehicle operator to deploy or to position the device clear of the vehicle/trailer doors when access is desired for loading or unloading the vehicle. There is also a need for a drag reduction device that has a lower profile than existing devices—i.e., that does not extend excessively beyond the end of the vehicle—to lessen the chance for damaging contact when the vehicle is moved in reverse.

DESCRIPTION OF THE FIGURES

FIG. 1 is a perspective view of the rear of a vehicle or trailer with a drag reduction device mounted thereon.

FIG. 2 is a perspective view of the device shown in FIG. 1, depicted with the rear door of the vehicle or trailer partially opened.

FIG. 3 is a top view of the device shown in FIG. 2 with rear door partially open.

FIG. 4 is a top view of a hinge component of the device depicted in FIG. 3.

FIG. 5 is a top view of the drag reduction device depicted in FIG. 3, shown with the rear door opened further.

FIG. 6 is a top view of the drag reduction device depicted in FIG. 3, shown with the rear door fully open and the drag reducing device in its fully stowed position.

FIG. 7 is a top view of the drag reduction device depicted in FIG. 6, shown with the rear door fully closed and the drag reducing device in its deployed position.

FIG. 8 is a rear perspective view of a drag reduction device according to a further embodiment, shown with the device in its deployed position.

FIG. 9 is top view of a drag reduction device shown in FIG. 8 with the device in its deployed position.

FIG. 10 is top view of a drag reduction device shown in FIG. 8 with the device in its stowed position.

FIG. 11 is a top perspective view of a drag reduction device according to a further embodiment in its deployed position.

FIG. 12 is a top view of the drag reduction device shown in FIG. 11.

FIG. 13 is a top view of the drag reduction device depicted in FIG. 11, shown with the device in its stowed position.

FIG. 14 is a top perspective view of a drag reduction device according to a further embodiment, shown with the device in its deployed position.

FIG. 15 is a top view of the device shown in FIG. 14.

FIG. 16 is an enlarged top view of an attachment element for use with the device shown in FIG. 15.

FIG. 17 is a top view of a drag reduction device according to yet another embodiment with the device in its deployed position.

FIG. 18 is a top view of the drag reduction device shown in FIG. 17, with the rear door partially opened.

FIG. 19 is a top view of the device shown in FIG. 17, with the device in its stowed position.

FIG. 20 is a perspective view of the rear of the vehicle or trailer having a sliding cover system with a drag reduction device according to an additional embodiment.

FIG. 21 is a top view of the drag reducing device of FIG. 20 shown in its stowed position.

FIG. 22 is an enlarged view of a tension element used with the drag reducing device shown in FIG. 20.

FIG. 23 is a bottom perspective view of a locking mechanism for a drag reducing device of another embodiment, shown with the locking mechanism in its latched position.

FIG. 24 is a rear perspective view of lower portion of the locking mechanism shown in FIG. 23.

FIG. 25 is a rear perspective view of the upper portion of the locking mechanism illustrated in FIG. 23, shown with the locking mechanism in its unlatched position.

FIG. 26 is a rear perspective of the lower portion of the locking mechanism shown in FIG. 25.

FIG. 27 is a rear perspective view of a locking mechanism according to a further embodiment for use with the sliding cover system of FIG. 20, with the mechanism shown in the locked position and the drag reducing device in its deployed position.

FIG. 28 is a rear perspective view of the locking mechanism shown in FIG. 27, with the mechanism moving from its locked to its unlocked position.

FIG. 29 is a rear perspective view of the locking mechanism shown in FIG. 28, with the mechanism in its unlocked position and the drag reducing device in its stowed position.

FIG. 30 is a top view of a side drag reducing device for use with a sliding cover system according to a further embodiment, with the device shown in its deployed position.

FIG. 31 is a top view of the side drag reducing device of FIG. 30 with the device shown in its stowed position.

FIG. 32 is a rear perspective view of a top drag reducing device shown in its deployed position.

FIG. 33 is rear view of the top drag reducing device of FIG. 32 shown in its stowed position.

FIG. 34 is a top view of the top drag reducing device of FIG. 33 as well as a side drag reducing device, both in their stowed positions.

FIG. 35 is a bottom perspective view of a top drag reducing device according to another embodiment.

FIG. 36 is a rear perspective view of a top drag reducing device according to a further embodiment shown in its deployed position.

FIG. 37 is a top view of the top drag reducing device shown in FIG. 36.

FIG. 38 is a perspective view of the top drag reducing device shown in FIG. 36 with the device in its stowed position.

FIG. 39 is a side view of an extrusion for a top drag reducing device according to yet another embodiment.

FIG. 40 is a rear perspective view of top and side drag reducing devices mounted on a vehicle having a roll-up rear door.

FIG. 41 is an enlarged view of the drag reducing devices illustrated in FIG. 40, shown with the devices in their stowed positions.

FIG. 42 is an enlarged perspective view of the drag reducing devices illustrated in FIG. 40, shown with the devices in their deployed positions.

DETAILED DESCRIPTION

For the purposes of promoting an understanding of the principles of the invention, reference will now be made to the embodiments illustrated in the drawings and described in the following written specification. It is understood that no limitation to the scope of the invention is thereby intended. It is further understood that the present invention includes

any alterations and modifications to the illustrated embodiments and includes further applications of the principles of the invention as would normally occur to one skilled in the art to which this invention pertains.

According to one embodiment, a drag reducing device **10** is mounted to the rear of a trailer T, as depicted in FIGS. 1-7. In particular, the device **10** is mounted between the side wall S of the trailer and a rear door D. The rear door D can be of a typical configuration to rotate outward about a hinge H, as shown in FIG. 3. As also shown in those figures, the drag reducing device remains attached to the side wall S and rear door D as the door is pivoted from its closed position, depicted in FIG. 7, to its open position, illustrated in FIG. 6. The device **10** includes a pair of mounting components for attaching the device to the vehicle, including a rear plate **12** and a side plate **14** connected by an air turning component **16**. Each of the plates **12**, **14** and air turning component **16** are elongated to be at least nearly co-extensive with the height of the rear door D, as best seen in FIG. 1. Optimally, the device **10** extends along the entire height of the trailer body T.

The rear plate **12** mounting component is attached to the rear door D by a hinge **20**. Likewise, the side plate **14** mounting component is attached to the side wall S of the trailer T by a hinge **26**. In one embodiment, the hinges **20**, **26** may extend along the entire length of the plates, such as a piano hinge. However, other hinge arrangements are contemplated that permit a suitable range of rotation, such as a series of hinges, a keder or other suitable hinge configurations. For instance, as seen by comparing FIGS. 6 and 7, the hinge **26** attached to the trailer side wall S is configured so that the side plate **14** can pivot almost 180° between the actuated or deployed position of the device (FIG. 6) and the stowed position (FIG. 7). Similarly, the hinge **20** connecting the rear plate **12** to the door D pivots through about 120° from the deployed position to the stowed position.

The air turning component **16** is connected to the two plates by respective hinges **22**, **24**. The angular range of relative movement at the hinges **22**, **24** is not as great as for the hinges **20**, **26**. In one embodiment, the hinge **22** between the rear plate **12** and the air turning component **16** is a piano hinge. The hinge **24** between the air turning component and the side plate **14** may have a different configuration, as shown in detail in FIGS. 4-5. In this embodiment, the hinge **24** is an interlocking pivoting arrangement that includes an elongated channel **30** defined on the side plate **14** and a mating elongated bead **32** defined on the air turning component **16**. The bead **32** is configured to slide into the channel **30** in a close running fit. The air turning component includes a flange **34** that projects toward the side plate **14** and contacts a rib **36** on the side plate to limit the relative rotation of the air turning component **16** toward the side plate **14**. In particular, as shown in FIG. 7, the flange **34** contacts the rib **36** when the device **10** is deployed. As the device moves to its stowed position remains in contact for part of the movement, as shown in FIG. 3, but then moves out of contact with the rib as the door is pivoted further, as reflected in FIGS. 5 and 6. The flange **34** may contact the rear door D when the device is fully stowed (i.e., the door is fully open), as shown in FIG. 6. The hinges **22**, **24** are configured to allow the device **10** to fold to as small a width as possible, limited only by the width of the air turning component **16**. In a preferred embodiment, the air turning component **16** is configured to a width W (FIG. 6) of 2-4 inches, which allows the rear door D to be fully opened in accordance with typical usage of the trailer T.

As shown in FIG. 7, the air turning component **16** defines a smooth arcuate surface **17** from the side wall S of the trailer to the rear of the trailer. The component is configured to “turn” the air flow F through an angle α that reduces the turbulence and prevents flow separation at the rear of the trailer. It has been found that “turning” the air flow F in this manner reduces the pressure drag as the vehicle moves through the air. In one embodiment, the air turning component **16** is configured to produce an angle α of greater than 10°. In certain embodiments the component **16** is configured to produce an angle α of about 30°, which is believed to provide an optimum drag reducing effect. The outer surface **17** of the component **16** is thus configured at a radius, which in certain embodiments may be greater than 2.0 in. and less than 6.0 in. In one specific embodiment the outer surface is defined at a radius of about 4.0 in. to provide a balance between the air flow turning angle and the profile or prominence of the device.

It is further contemplated that the side plate **14** may be arranged at an angle β relative to the side S of the truck/trailer. This angle merges into the air turning component to provide for a smooth transition of the airflow from along the side of the vehicle to the turning component **16**. The angled side plate also allows the device to fit around trailer appurtenances, such as the door hinges. It is believed that this transition helps collimate the air flow which in turn reduces the risk of flow separation or turbulence at the air turning component. In one embodiment the angle β is no greater than about 5°. It can be appreciated that the flange **34** may be arranged to abut the side wall S when the device **10** is in its active deployed position. The overall width of the hinge **24**, or more specifically the height of the rib **36**, may thus be adjusted to determine the angle β .

The air turning component **16** may be formed as an extrusion of a durable material, such as aluminum or stainless steel, or extruded or molded from a durable plastic, such as ABS plastic. The extrusion may incorporate a generally hollow interior frame **16a** (FIG. 5) inside the inner surface of the component that helps the component resist crushing in the stowed position or resist impacts when in the deployed position. The frame **16a** may also be configured to house other components to assist in the drag reducing function of the device **10**. For instance, if the device incorporates certain active device components, such as plasma actuators and vehicle lights, the components may be housed within the interior frame **16a**.

It can be appreciated from the sequence depicted in FIGS. 1-7 that the device **10** can be deployed and stowed without any intervention by the vehicle operator. The device **10** moves with the rear door D so that when the door is closed, as shown in FIG. 7, the device is automatically situated in its deployed or actuated position. When the door is opened, as shown in FIG. 6, the device **10** automatically moves to its stowed position. The air turning component **16** is the primary functional component of the device since it is the curvature of the surface **17** that turns the airflow at the rear of the vehicle. The device **10** is configured so that the air turning component **16** is supported by the plates **12**, **14** in all positions of the device. The air turning component **16** is large enough to present a sufficient surface to effectively turn the air flow, but is small enough in width W so that the device **10** does not interfere with the normal opening of the rear doors D of the trailer.

It can be appreciated that the side plate **14** of the device provides a smooth, seamless transition from the side wall S of the trailer to the air turning component **16**. The hinge arrangement **24** between the side wall and the air turning

component allows for an uninterrupted surface from the surface of the side plate to the outer surface 17 of the air turning component. The hinges 20, 22, 24 and 26 can be configured so that when the device 10 is deployed (FIG. 7) the hinge 24 is tightly closed so that only a negligible seam exists at the interface between the side plate and air turning component.

In an alternative embodiment, the plate 12 may be replaced with a retraction element, such as the retraction element 40 of the drag reducing device 10' illustrated in FIGS. 8-10. The device 10' includes a side plate 14 mounted to the side S of the truck or trailer by a hinge 26. The side plate 14 is connected to the air turning component 16' by a hinge 24. The hinges 24, 26 and side plate 14 of the device 10' in FIG. 8 may be constructed as like components of the device 10 in FIG. 3. Unlike the device of FIG. 3, the device 10' uses a number of retraction elements 40 as a mounting component in lieu of the rear plate 12. Each retraction element 40 is configured to exert an elastic force on the air turning component 16' to hold the component in its deployed position, as shown in FIGS. 8-9. In one embodiment, each retraction element includes a resilient elastic band or strap 41 connected at one end to a rear door D and at an opposite end to the air turning component 16'. The ends of the elastic strap 41 may include fittings 43, 45 adapted to engage hooks 42, 44. The hook 42 are further connected to a fitting 22' on the air turning component 16', while the hook 44 is connected to a fitting 46 mounted to the rear door D. It is contemplated that multiple retraction elements 40 are engaged between the device 10' and the rear door at spaced apart positions. Preferably, at least three such retraction elements are used.

The retraction elements 40 act in a manner similar to the rear plate 12 of the previous embodiment. When the device 10' is in its deployed position, as shown in FIG. 9, the retraction elements apply a force to pull the air turning component 16' toward the rear door. The elastic force of the band 41 is resisted by the contact between flange 34 and rib 36 which prevents further rotation of the air turning component 16' toward the door. When the door D is opened to the position shown in FIG. 10, the retraction elements 40 keep the air turning component 16' tight against the rear door.

The retraction elements 40 may be connected to the rear door D and air turning component 16' using other types of connectors. The retraction elements may utilize other resilient and/or elastic elements, such as springs; however, the elastic bands 41 provide a unitary structure that is better able to withstand road vibration and dirt. The elastic bands are also easily replaced by simply removing the hooks 42, 44 from the corresponding fittings 43, 45.

In an alternative embodiment shown in FIGS. 11-13, a drag reducing device 10" includes an air turning component 16" in the form of an elongated extrusion in which the outer surface 17" follows the curvature described above to turn the air flow. The extruded turning component 16" is attached to a side plate 14", and more particularly to an inward flange 15" of the plate. The side plate 14" is connected at a hinge 26" to a mounting plate 27" that is mounted to the side S of the vehicle. The hinge 26" permits the full range of pivoting of the air turning component and side plate from the deployed position of FIG. 12 to the stowed position of FIG. 13. The hinge 26" may thus be constructed like the hinges described above.

The mounting plate 27" includes an outwardly projecting flange 28" against which the side plate 14" bears when the device is deployed, as shown in FIGS. 11-12. This flange

thus maintains the side plate at a predetermined angle relative to the side S of the vehicle to impart the angle β described above (see FIG. 7). The device 10" incorporates a retraction element 40" that serves as the mounting component connected between the extrusion 16" and the door D. The retraction element includes a lanyard or tether 41" that is generally non-extensible, unlike the strap 41 described above. The lanyard is fastened at end 46" to the door D and at the opposite end 42" to the extrusion 16", such as by way of a machine screw or other similar fastener. As shown in FIG. 13 the lanyard flexes or folds when the device 10" is in its stowed position. As with the other embodiments the device 10" and particularly the extrusion 16" is configured so that only a minimal gap exists between the door D and side S of the vehicle.

In the embodiments of FIGS. 1-13, the devices 10, 10' are continuously attached to both the rear door and side wall of the truck/trailer. In an alternative embodiment the leading end of the device may be disengageable from the trailer. Thus, as shown in FIGS. 14-16, a device 50 may include a rear plate 52 that is attached to the rear door D by a hinge 56, in the same manner as described above for rear plate 12 described above. The device 50 includes an air turning component 54 that is connected by a hinge 58 to the rear plate 52 at its trailing edge. The component 54 is configured to produce the air turning effects described above and may have the same general configuration as the turning components 16, 16'. The component 54 may thus be configured so that the outer surface 55 follows a radius of greater than about 3.0 in. to turn the air flow at the angle α of greater than 15°.

The leading edge of the air turning component 54 includes mounting component in the form of a side plate having an attachment element 60 that removably engages a socket 62 mounted to the hinge frame of the rear door. The attachment element 60 may include cut-outs 61 aligned with the hinges H of the rear door D to allow the attachment element to sit as flush to the side wall S of the trailer as possible. In one embodiment, the attachment element may include a magnet 66 that magnetically adheres the attachment element 60 to the socket 62. A flange 64 may be provided to engage the socket 62 to hold the device 50 against accidental disengagement. In an alternative embodiment, the magnet 66 may be replaced with a push-in type barbed fastener 66', as shown in FIG. 16. The socket 62' may be configured so that the opening 63' engages the barbs of the fastener 66' to prevent its inadvertent dislodgment.

It is understood that a plurality of attachment element and socket combinations are provided along the length of air turning component 54. The magnets 66 may be permanent magnets that are sufficiently strong to hold the leading edge of the component 54 against the side wall S under the typical maximum air speed passing along the side the vehicle. However, the magnetic engagement between the sockets and magnets must not be too strong that the device cannot be manually disengaged from the trailer.

In this embodiment, the device 50 requires intervention to disengage the attachment element 60 from the socket 62. The device may incorporate an internal frame 68, similar to the frame 16a of FIG. 5, which helps maintain the integrity of the air turning component as it is grasped by the vehicle operator to disengage all of the attachment elements 60 from all of the sockets 62. As with the prior embodiments, the hinge 56 allows the rear plate 52 to pivot so that it rests against the rear door D when the door is fully opened. The hinge 58 between the component 54 and rear plate 52 allows the component to pivot inward toward the rear plate when

the device 50 is in its stowed position. The hinge 58 may be spring biased so that the component 54 automatically pivots inward when the device 50 is disengaged from the socket 62. It is contemplated that this embodiment may be used with a vehicle having a single door, rather than the two side-swing doors in the illustrated embodiment.

Another automatically deployed embodiment is depicted in FIGS. 17-19. In this embodiment, the drag reducing device 70 includes a rear component 72 mounting component that is fastened to the rear door by a hinge 80, in a manner similar to the prior embodiments. A front plate 74 mounting component is similarly attached to the side wall of the trailer by a hinge 86. An air turning component 76 is connected between the rear component 72, by a hinge 82, and the front plate 76, via a hinge 84. The drag reducing device 70 may incorporate an interlocking hinge arrangement or keder for both hinges 82 and 84. As shown in FIG. 17, the component 76 is configured to turn the air flow at an angle α of greater than 15° in a manner similar to the above-described embodiments.

In this embodiment, the rear component 72 is not a rigid plate, as in the prior embodiments, but a flexible plate. In the deployed position, the flexible rear component 72 bows outward away from the rear door, as shown in FIG. 17. When the rear door D is pivoted to its open position, the rear component 72 forms a slight bend 87 at the hinge 80, as illustrated in FIG. 18. The hinge 82 between the rear component 72 and the air turning component 76 allows the rear component to bow slightly at the interface to the air turning component. As the door continues to pivot forward, the flexible rear component 72 forms a bowed portion 88 adjacent the air turning component 76. The two bowed portions 87 and 88 allow the flexible component to assume a thin profile when the rear door D is fully opened, as depicted in FIG. 19.

As with the device 10, the drag reducing device 70 does not require any operator intervention to deploy or stow. The natural stiffness of the rear component 72 holds the air turning component 76 in its proper position. The hinge 86 for the front plate 74 may be spring biased to hold the front plate against the side wall of the trailer to assist in maintaining the air turning component in its proper orientation.

The drag reducing devices disclosed herein may be configured for use on a sliding cover system, such as the CONESTOGA® rolling tarp system manufactured and sold by Aero Industries, Inc. Thus, in one embodiment, a drag reducing device 120 is mounted to the rear frame structure B of a sliding cover system SC, as depicted in FIGS. 20-22. A pair of such devices 120 are mounted to the rear frame structure B on each side of a rear closure RC (which may be a curtain or roll-up door, for instance) and are held in their deployed positions by a tension element 122 spanning the closure. As shown in FIGS. 21-22, the tension element may be a strap that may be tightened by a ratchet element 123 mounted by a bracket 128 to an inner surface 127 of the device 120.

The device 120 may be in the form of a continuous extrusion, as depicted in FIG. 21. The extrusion defines a curved air turning surface 125 that is configured similar to the outer surface 17 of the air turning component 16 described above. In particular, the surface 125 may be configured to provide a smooth curved surface to turn the air flow by an angle of greater than 10° and in a specific embodiment about 30° . The device 120 is mounted to the rear frame structure B by a pivot mount 126 that may take on a variety of forms, such as a piano hinge, a sleeve and pintle, an interlocking rod and channel configuration or a

keder. Since there is no outwardly swinging rear door, as in the prior embodiments, there is no special need for the device 120 to pivot fully against the sliding cover SC. Where the rear closure RC is a curtain, the device may incorporate a rear curtain clamp 129 extending from the inner surface 127 and arranged to pinch the rear curtain against the rear frame structure B when the device is in its deployed position. The rear curtain clamp also reacts the tension applied by the tensioning element 122 when the tensioning element is connected to the devices at opposite sides of the rear closure RC.

In an alternative embodiment, the tensioning element is replaced by a latch mechanism, such as the mechanism 132 included in the drag reducing device 130 shown in FIGS. 23-26. The drag reducing device 130 may be configured like the device 120 with a pivot mount 130a (FIG. 26) to the trailer rear frame structure B, a stiffening bracket 130b and an air turning surface 130c as described above. The latch mechanism 132 includes a latch rod 136 that is slidably supported by upper and lower brackets 134 and 135, respectively, mounted to the inner surface 131 of the device. The rod 136 is mounted to slide upward into engagement with a latch plate 140 fastened to the rear frame structure B, as shown in FIG. 23, and downward to disengage the latch plate, as shown in FIG. 25.

The latch rod is moved upward by a cam lever 137 that is mounted to the inner surface 131 at a pivot mount 138. The lever includes a cam surface 139 that contacts the latch rod 136 and is configured to move the rod upward upon rotation of the lever from the vertical orientation shown in FIG. 24 to the horizontal orientation shown in FIG. 26. A stop 140 prevents over-rotation of the cam lever 137, holding the lever in its vertical orientation to keep the lever within the envelope of the drag reducing device 130. The cam lever is manually operated to unlatch the device 130 from the rear frame structure B so that the device can be pivoted clear of the rear closure.

FIG. 27 depicts an alternative locking mechanism 150 for use with the side drag reducing device 130', similar to the device shown in FIGS. 21-26. In this embodiment the extrusion forming the device 130' is modified to include a cut-out 130d with a back wall 130e at the bottom of the device, as shown in FIGS. 27-29. The locking mechanism 150 includes a thumbwheel actuator 151 that is used to move a pressure plate 152 into engagement with a receiver plate 154 fastened to the back wall 130e of the device 130', as shown in FIG. 27. The receiver plate 154 may incorporate a recess within which the pressure plate 152 is seated when the pressure plate is clamped onto the receiver plate. The thumbwheel actuator is supported by a mounting block 153 carried by a pivoting bracket 155. The thumbwheel actuator 151 and mounting block 153 are configured so that manual operation of the actuator 151 firmly clamps the pressure plate 152 onto the receiver plate 154. Thus, a threaded interface may be provided in which the thumbwheel actuator is rotated to engage and release the pressure plate 152. Other interfaces are contemplated including a spring-biased interface that biases the pressure plate to the clamped position shown in FIG. 27. In this specific embodiment the thumbwheel actuator would be manually retracted to release the pressure plate from the receiver plate.

The locking mechanism 150 is pivotably mounted to the rear frame structure B so that the mechanism can pivot from the locked position in FIG. 27, to the intermediate position of FIG. 28, to the unlocked position depicted in FIG. 29. In one specific embodiment, the pivoting bracket 155 is attached to the rear frame structure B by a pivot mount 156

that may take on a variety of forms that allow the range of pivoting motion depicted in the figures. It can be appreciated that when the locking mechanism **150** is in its unlocked position of FIG. **29** the drag reducing device **130'** may be pivoted outward away to the side of the rear frame structure to allow access to the rear closure RC (FIG. **21**).

A side drag reducing device **160** is shown in FIGS. **30-31** for use with a sliding cover system, such as the system discussed above. The device includes an extruded body **161** having a curved outer surface **162** that includes a portion **162a** that is curved to produce the air turning feature described herein. The outer surface may further incorporate a generally linear portion **162b** as also discussed above. The extrusion is fastened to the rear frame structure B of the sliding cover system by way of a hinge **170**. The hinge **170** is configured so that the device **160** may pivot from the deployed position shown in FIG. **30** to the stowed position shown in FIG. **31**. The extruded body **161** may further include an inner wall **164** and a rear wall **165**. The rear wall may support a receiver plate **154** to incorporate the locking mechanism **150** described above.

In one feature of the device **160**, the inner wall **164** projects toward a curtain clamping base CB of the cover system in which the rear closure RC is a curtain. As shown in FIG. **31**, the rear curtain includes a side bead E on each side of the curtain that is aligned with the clamping base CB. The side bead adds some rigidity to the rear curtain and facilitates closing the curtain. For instance, in certain flexible cover systems, such as the CONESTOGA® cover system manufactured by Aero Industries, Inc., the side bead E is engaged by a rear curtain hinged clamp that may be mounted to the hinge **170**. The hinged clamp compresses the side bead E into the clamping base to engage and seal the rear curtain to the rear frame structure B. In accordance with the present embodiment of the side drag reducing device **160**, the inner wall **164** terminates in an end plate **167** that extends the length of the extruded body **161**, which in turn extends for substantially the entire length of the rear curtain. The inner wall **167** acts as a rear curtain clamp to compress the side bead E into the clamping base CB as shown in FIG. **30**. With this feature the drag reducing device **160** can replace the curtain hinged clamp with no modification to the rear frame structure.

The air turning aspect can also be implemented at the top rear edge of the trailer, or more particularly generally contiguous with the rear edge of the roof of the vehicle/trailer. As depicted in FIG. **1**, an upper drag reducing device **200** may be provided that can be deployed and stowed without interfering with the ability to fully open the rear doors. A pair of devices may be mounted to the rear doors D, leaving a gap G as needed to accommodate rear lights of the trailer or vehicle. The device **200** may be include an extrusion **201**, as shown in FIGS. **32-34**, that extends along half the width of the trailer T (when two separate devices are used), or that extends across the entire width of the trailer (when a single device is used). The extrusion **201** includes a leading surface **202** and a trailing surface **204**, in which the leading surface may be curved in the same manner as the side-mounted device, such as device **10** discussed above. Thus the curvature of the leading surface is configured to turn the airflow through an angle of at least 10° and in a specific embodiment by about 30°. The trailing surface **204** may emulate the surface **162** of the side mounted device shown in FIG. **30** to reduce turbulence as the airflow leaves the leading surface **202**. A downward flange **206** may project from the front edge of the leading surface **202**. The flange may be configured to abut the rear of the roof R of the trailer,

or may be configured to seat within a channel or trough in the roof. Engagement between the flange **206** and the roof of the vehicle maintains the leading surface generally contiguous with the roof and ensures a smooth airflow transition from the roof to the drag reducing device **200**.

The extrusion **201** includes a bottom wall **210** that is hingedly connected to the vehicle door D. A stiffening rib **208** may be provided between the bottom wall and upper surface. The rib further defines a generally enclosed compartment **209** that can may house various components, such as a plasma actuator operable to generate a plasma airflow across the upper drag reducing device **200**. In one embodiment a hinge **212** is provided that allows the extrusion **201** to pivot forward relative to the door D when the door is opened and the device is in its stowed position shown in FIGS. **33-34**. The hinge may be configured to limit the rearward movement of the device **200** away from the door so that the flange **206** always abuts the trailer when in the deployed position. When the rear door D is opened, the trailing surface **204** contacts the side wall S of the trailer, which caused the extrusion **201** to pivot about the hinge **212** over the top edge of the door, as shown in FIG. **33**. This feature allows the top drag reducing device **200** to pivot clear of the space between the door D and trailer side S so that the door can be fully opened, as best shown in FIG. **31**.

A retraction element **220** may be provided that restores the drag reducing device **200** to its operative position when the door D is moved from the open position of FIGS. **33-34** to the closed position shown in FIG. **29**. In one embodiment the retraction element may be similar to the retraction element **40** shown in FIG. **8**, in particular including an elastic band **221**, connected by hooks **223**, **225** to the vehicle door D and extrusion **201**, respectively.

In certain embodiments the device **200** may be configured to extend across the entire width of both rear doors D, rather than including the gap G shown in FIG. **1**. It can be appreciated that the gap G corresponds to the location of the upper rear lights for the trailer. In embodiments where the device extends uninterrupted across the width of the trailer the extrusion **201** may be formed of a generally transparent material so that the vehicle lights are visible through the extrusion. Thus, the extrusion may be formed of a polycarbonate resin thermoplastic, or other transparent and durable plastic or polymer material. In other embodiments the length and angle of the trailing surface **204** may be modified so that it does not visually interfere with the rear trailer lights.

Alternatively, the extrusion **201'** of the device **200'** may be modified to include a notch **230** formed in the trailing surface **204'**, as shown in FIG. **35**. The notch is aligned with the lights on the rear of the trailer or on the rear doors D so that the light are visible when the device **200'** is deployed. The notch need only be defined in the underside of the extrusion **201'** since the lights will be viewed from below the level of the device **200'** mounted on the truck/trailer.

A top drag reducing device **250** is shown in FIGS. **36-38** that is supported on the rear door D by angled struts **260**. The device **250** includes an air flow turning component **251** in the form of an extrusion that forms a leading surface **252** and a trailing surface **254**. The leading and trailing surfaces can be configured like the leading and trailing surfaces described above to turn the air flow in the manner also described above. The leading edge **253** is configured to abut the rear of the trailer to provide a smooth air flow transition from the over the roof of the trailer to the drag reducing device **250**.

The extrusion **251** further includes a support plate **256** that may include a pair of C-shaped channels **257**, **258** running along the length of the extrusion. The channels **257**,

258 may be configured to receive a sliding fastener, such as a fastener for attaching the angled struts **260** to the extrusion. In another embodiment the angled struts are attached directly to the support plate **256**, such as by welding or a mechanical fastener. The angled struts are mounted to the rear door D by a corresponding pair of hinges **262**. The hinges are configured to be closed when the device **250** is in its deployed position, as shown in FIG. **36**. The hinges are opened when the door is opened, as shown in FIG. **38**, so the device **250** can pivot over the top of the door so as not to impede movement of the door to the fully opened position. The hinges are preferably spring biased to bias the struts to the deployed position of FIG. **36** in order to maintain the leading edge **253** in tight contact with the rear of the trailer.

The leading edge **253** of the leading surface **252** may abut a generally planar gutter foil **270** (FIGS. **36-37**) that is mounted to the rear of the roof R of the trailer. The gutter foil **270** is configured to sit over one or more rear gutters of the trailer, extending forward from the rear to span a desired number of gutters. The gutter foil reduces the airflow turbulence produced as the air passes over the disruptions in the roof surface created by the gutters. Since the gutters do not span the entire width of the trailer, as seen in FIG. **37**, the function of the gutters is not impaired. Moreover, the gutters may be perforated to permit water flow into the gutters. In certain embodiments the leading surface **252** of the device may be modified to incorporate the gutter foil. In this modification, the leading surface would extend forward over gutters when the device is deployed.

A modified extrusion **280** for a top drag reducing device is shown in FIG. **39** which is configured for use alternatively in a panel trailer configuration, like the device **250**, or with a sliding cover system. The extrusion includes a leading surface **281**, a turning surface **283** and a trailing surface **284**. The turning and trailing surface may be configured as described above to turn the air flow and prevent turbulence. The leading surface **281** may include a generally planar portion **282** provided to extend the airflow turning effect farther to the rear of the vehicle so that the leading surface can help collimate the airflow exiting the roof of the trailer or sliding cover system. The leading surface **281** may thus act as the gutter foil **270** discussed above.

The extrusion includes a support plate **287** with a pair of C-shaped channels **288**, **289** for mounting components or support struts thereto. The extrusion further includes a rear panel **290** that may be configured to abut the rear of the trailer or rear frame structure. The rear panel may include a C-shaped channel **291** that is configured to receive a bead E of a rear curtain closure RC. The rear panel **290** may further include a recess **292** for mounting the device directly to the upper portion of a rear frame structure. When the device **280** is used with a sliding cover system, the extrusion is fastened to the rear frame structure B via the recess **292** using conventional fasteners. A rear curtain closure RC may be carried by the device by mounting the top bead E within the channel **291**. In this instance the C-shaped channels **288**, **289** are not used.

Some vehicles/trailers utilize a roll-up rear door, such as the trailer T and rear door RD depicted in FIG. **40**. In one embodiment, side drag reducing devices **300** and a top drag reducing device **320** are mounted to the rear frame of the vehicle. As best seen in FIGS. **41-42**, the devices **300**, **320** are modified from the device **280** shown in FIG. **39**. In particular, the devices **300**, **320** do not include the planar portion **282** or the rear panel **290**. On the other hand, the devices **300**, **320** do include a turning surface **303**, **323**, and a trailing surface **304**, **324**, as well as the channels **305**, **325**

projecting from a support plate **307**, **327**. The devices are mounted by hinges **302**, **322** to the respective sides and top of the rear frame supporting the roll-up rear door RD. The hinges may be spring-biased to bias the respective drag reducing device to either the deployed or stowed position. In one embodiment, the hinges **302**, **322** are spring biased to bias the devices to the stowed positions depicted in FIG. **41**.

In one aspect, the drag reducing devices are held in their deployed position shown in FIG. **42** by cables or cords **330**. In one specific embodiment the cables **330** are bungee cords or other elastic cable to provide a restraining force sufficient to hold the drag reducing devices in their deployed position in spite of road shock and vibrations. As depicted in FIG. **40**, the cables **300** are mounted cross-wise between the top drag reducing device **320** and each side drag reducing device **300**. The cables may be specifically mounted within the channels **305**, **325** of the devices using appropriate fasteners. In an alternative approach, a set of cables may be connected between the top drag reducing device **320** and the base of the rear frame of the vehicle and another set of cables can be connected directly between the two side drag reducing devices (similar to the strap **122** shown in FIG. **20**).

In each of the top drag reducing devices described above it can be appreciated that the devices provide drag reduction features without projecting appreciably above the roof R of the vehicle/trailer. Vehicles of this type are subject to height restrictions. In many cases, the vehicle/trailer is manufactured to maximize the enclosed volume to thereby maximize the amount of load that can be transported. Thus, vehicle/trailer manufacturers make the vehicles/trailers as tall as possible, or more specifically as close to the legal height limits as possible. Since the height restrictions apply to anything mounted to the vehicle/trailer, most prior top drag reducing devices mounted to the roof R cause the vehicle to exceed the height limits. The top drag reducing devices **200**, **250**, **280** and **320** disclosed herein are essentially flush with the surface of the roof R and in some cases, lower than the gutter structure of some vehicles/trailers.

In all the embodiments the drag reducing device includes a contoured or curved surface that is configured to turn the airflow passing the rear of the trailer or vehicle. In preferred embodiments the surface turns the airflow at least 10°, and in a specific embodiment about 30°, as the air flows past the drag reducing devices. This modified airflow reduces turbulence at the rear of the vehicle and thus reduces drag. It is further contemplated that the trailing end of the air flow turning components may incorporate a generally straight section followed by an additional curved section to turn the air flow further toward the rear of the vehicle. The additional curved section may be calibrated in conjunction with the first curved section to turn the air flow to optimize the drag reduction performance of the device. The drag reducing devices disclosed herein may incorporate an extruded air turning component that can also be used to house additional drag reducing components, such as plasma actuators. For these modified devices the curved surface may be defined at a different radius than discussed above. In particular, the addition of certain plasma actuators can achieve the desired airflow turning angle with a curved surface having a radius less than 3.0 inches, and in a specific embodiment a radius of 2.0 inches.

In each of the embodiments an extrusion is provided as the air turning component. The extrusion allows tailoring the device to the size of the particular truck/trailer. Thus, the side drag reducing devices may be cut to match the height of a particular vehicle, while the top drag reducing devices may be cut to the width of the vehicle. In many cases it is

desirable for the drag reducing devices to be as long as the vehicle permits in order to maximize the drag reducing performance.

What is claimed is:

1. A drag reducing device for a vehicle, the vehicle having opposite side walls, a rear perimeter with a rear opening and two rear doors, each door pivotably mounted to said rear perimeter at a corresponding one of the side walls and movable between a fully-opened and a fully-closed position relative to the opening, the device comprising:

an air flow directing component associated with each of the opposite side walls and each of the rear doors, the air flow directing component configured to extend rearwardly of the vehicle at least partially along the height of the vehicle, each air flow directing component including;

a plate pivotably mounted to a corresponding one of the opposite side walls, said plate pivotable relative to the vehicle between a deployed position wherein said plate extends rearwardly relatively to the vehicle and a stowed position wherein said plate extends forwardly along the vehicle and is adjacent the side wall of the vehicle;

a curved surface pivotably connected to said plate and connected to a corresponding one of said rear doors, said curved surface pivotable relative to the vehicle between a deployed position in which said curved surface extends rearwardly relative to the vehicle and a stowed position wherein said curved surface extends forwardly along the vehicle and is adjacent the side wall of the vehicle,

wherein the curved surface is configured to turn air flow passing over the curved surface when the curved surface is in the respective deployed position, and

wherein said plate and said curved surface are automatically moved to the respective deployed positions when the corresponding one of the rear doors is moved to the fully-closed position, and wherein said plate and said curved surface are automatically moved to the respective stowed position when the corresponding one of the rear doors is moved to the fully-opened position.

2. The drag reducing device of claim 1, wherein said curved surface is a rigid curved surface.

3. The drag reducing device of claim 1, wherein said curved surface is pivotably connected to said plate by a hinge.

4. The drag reducing device of claim 1, wherein said curved surface is connected to the corresponding one of the rear doors by a flexible element.

5. The drag reducing device of claim 1, wherein the flexible element includes one or more of a cable, a strap and a lanyard.

6. A drag reducing device for a vehicle, the vehicle having opposite side walls, a rear perimeter with a rear opening and two rear doors, each door pivotably mounted to said rear perimeter at a corresponding one of the side walls and

pivotable between a fully-opened and a fully-closed position relative to the opening, the device comprising:

an air flow turning component, associated with each of the vehicle side walls, having a rigid curved surface configured to turn air flow passing over the rigid curved surface when the air flow turning component is moved to a deployed position;

a first mounting component connecting the air flow turning component to a corresponding one of the two rear doors; and

a second mounting component connecting the air flow turning component to a corresponding one of the opposite side walls, the second mounting component configured to support the air flow turning component extending rearward from the side walls in the deployed position,

wherein the air flow turning component, the first mounting component, and the second mounting component are configured so that when the corresponding one of the two rear doors is in a closed position, the air flow turning component is in the deployed position, and so that when the corresponding one of the two rear doors is in an open position, the air flow turning component is in a stowed position different from the deployed position; and

wherein the air flow turning component, the first mounting component, and the second mounting component are configured to remain connected between the corresponding one of the two rear doors and the corresponding one of the opposite side walls as the corresponding one of the two rear doors is pivoted between the fully-opened and the fully-closed position.

7. The drag reducing device of claim 6, wherein the rigid curved surface is defined at a curvature configured to turn the air flow passing the corresponding side wall toward the rear of the vehicle by at least 10°.

8. The drag reducing device of claim 6, wherein the rigid curved surface is defined at a radius of at least 2.0 inches.

9. The drag reducing device of claim 8, wherein the rigid curved surface is defined at a radius of between 3.0 and 6.0 inches.

10. The drag reducing device of claim 9, wherein the rigid curved surface is defined at a radius of about 4.0 inches.

11. The drag reducing device of claim 6, wherein the air flow turning component is an elongated extrusion having a length so that opposite ends of the extrusion are adjacent the top and bottom of the two rear doors of the vehicle.

12. The drag reducing device of claim 6, wherein the first mounting component includes a flexible element attached at one end to the air flow turning component and at an opposite end to the corresponding one of the two rear doors.

13. The drag reducing device of claim 6, wherein the flexible element includes one or more of a cable, a strap and a lanyard.

* * * * *