

(19) World Intellectual Property Organization
International Bureau



(43) International Publication Date
4 January 2001 (04.01.2001)

PCT

(10) International Publication Number
WO 01/00123 A1

- (51) International Patent Classification⁷: **A61F 13/15** (74) Agents: REED, T., David et al.; The Procter & Gamble Company, 5299 Spring Grove Avenue, Cincinnati, OH 45217-1087 (US).
- (21) International Application Number: PCT/US00/17500
- (22) International Filing Date: 23 June 2000 (23.06.2000) (81) Designated States (*national*): AE, AL, AM, AT, AT (utility model), AU, AZ, BA, BB, BG, BR, BY, CA, CH, CN, CR, CU, CZ, CZ (utility model), DE, DE (utility model), DK, DK (utility model), DM, EE, EE (utility model), ES, FI, FI (utility model), GB, GD, GE, GH, GM, HR, HU, ID, IL, IN, IS, JP, KE, KG, KP, KR, KZ, LC, LK, LR, LS, LT, LU, LV, MA, MD, MG, MK, MN, MW, MX, NO, NZ, PL, PT, RO, RU, SD, SE, SG, SI, SK, SK (utility model), SL, TJ, TM, TR, TT, TZ, UA, UG, US, UZ, VN, YU, ZA, ZW.
- (25) Filing Language: English
- (26) Publication Language: English
- (30) Priority Data:
99112229.2 25 June 1999 (25.06.1999) EP
- (71) Applicant (*for all designated States except US*): THE PROCTER & GAMBLE COMPANY [US/US]; One Procter & Gamble Plaza, Cincinnati, OH 45202 (US).
- (84) Designated States (*regional*): ARIPO patent (GH, GM, KE, LS, MW, MZ, SD, SL, SZ, TZ, UG, ZW), Eurasian patent (AM, AZ, BY, KG, KZ, MD, RU, TJ, TM), European patent (AT, BE, CH, CY, DE, DK, ES, FI, FR, GB, GR, IE, IT, LU, MC, NL, PT, SE), OAPI patent (BF, BJ, CF, CG, CI, CM, GA, GN, GW, ML, MR, NE, SN, TD, TG).
- (72) Inventors; and
- (75) Inventors/Applicants (*for US only*): FRANZMANN, Dirk [DE/DE]; Rothgerberbach 1, D-50676 Koln (DE). SCHMITZ, Christoph, Johann [DE/DE]; Dr.-Lieser-Str. 2, D-53881 Euskirchen-Stotzheim (DE).
- Published:
— With international search report.

[Continued on next page]

(54) Title: PROCESS FOR MANUFACTURING DISPOSABLE ABSORBENT CORES, AND AN APPARATUS FOR PERFORMING THE PROCESS

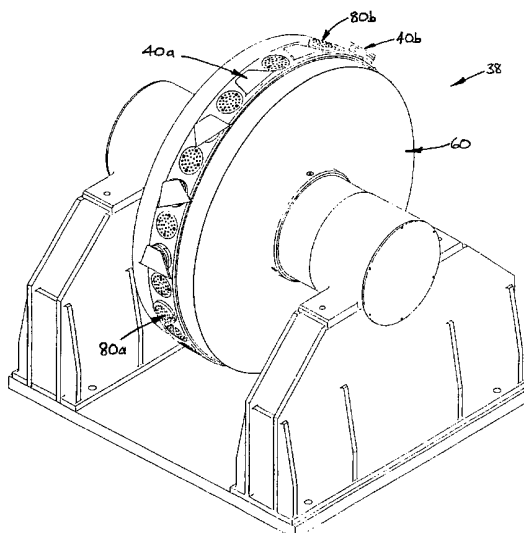

(57) Abstract: This invention provides a process and apparatus (38) for the manufacture of disposable absorbent cores from a continuous web (40), wherein a plurality of first and second core elements (40a, 40b) are cut from the same continuous web (40). The object of the invention is achieved by rotating each of first and second core elements (40a, 40b) about axes perpendicular to the plane of the core element and subsequently combining a first core element (40a) and a second core element (40b) in proximal relationship to form the absorbent core. Preferably each of the first and second core elements (40a, 40b) are rotated through 90° in mutually counter-rotating directions.



WO 01/00123 A1



For two-letter codes and other abbreviations, refer to the "Guidance Notes on Codes and Abbreviations" appearing at the beginning of each regular issue of the PCT Gazette.

**PROCESS FOR MANUFACTURING DISPOSABLE ABSORBENT CORES,
AND AN APPARATUS FOR PERFORMING THE PROCESS**

5

The invention relates to a process for manufacturing profiled disposable absorbent cores, without waste of the absorbent core material; and to an apparatus for performing the process. In particular, diapers or training pants may be made by the process of the invention having absorbent cores with an hourglass-shape for better fit around the legs of the wearer, but the process may also be applied to feminine hygiene articles, adult incontinence articles, and other disposable absorbent articles.

15 Disposable absorbent articles have become very popular in the market place today. Many of these articles include features such as absorbent cores providing a variety of functions including improved containment characteristics and better, more comfortable fit.

20 An overriding consideration in the construction of a disposable absorbent article is the cost of manufacturing the article, including the materials cost. The present invention provides methods for manufacturing absorbent cores for absorbent articles with little or no wasted material. Thus, the absorbent cores made by the process of the present invention can be provided at relatively lower cost than many of the absorbent cores that are currently manufactured using techniques in which material is wasted. Processes which reduce or avoid material waste are disclosed in the following references.

30 US-A-4 760 764, issued on 2nd August 1988, relates to manufacturing methods for disposable diapers which have an "egg-timer" profile. It is proposed to reduce production costs by making effective use of the absorbent core, and in particular by avoiding waste by cutting out and throwing away a part of the

absorbent core. This is achieved by providing "nested panels" in a single side panel web and then rearranging the panels, for example as shown in Figure 4 of the patent to form an absorbent pad.

5 WO96/21411, published on 18th July 1996, discloses a method for manufacturing shaped or contoured absorbent cores made from multiple pieces or layers. Wherein the multiple pieces or layers are cut from the same continuous web with "zero scrap".

10 It is an object of the present invention to provide an alternative method of achieving waste-saving benefits, and associated reduction of material costs.

The invention provides a process and apparatus for the manufacture of disposable absorbent cores from a continuous web, wherein a plurality of first and second core elements, are cut from the same continuous web.

15

Summary of the Invention

The object of the invention is achieved by rotating each of first and second core elements about axes perpendicular to the plane of the core element and subsequently combining a first core element and a second core element in proximal relationship to form the absorbent core. Preferably each of the first and second core elements are rotated through 90° in mutually counter-rotating directions.

20

25

Brief Description of the Drawings

Figure 1 shows a perspective view of an apparatus for use in the process of the present invention;

30

Figure 2 shows a side elevation view of the apparatus of Figure 1;

Figures 3a and 3b show rear and front elevation views of the apparatus of Figure 1;

5 Figure 4 shows a schematic side elevation view of a production line assembly comprising an apparatus of the present invention;

Figure 5a shows a plan view of core elements after cutting, according to one embodiment of the process of the present invention. Figure 5b shows a plan
10 view of an absorbent core made by combining a first core element and a second core element of Figure 5a.

Detailed Description of the Invention

15 Incontinence management articles, such as non-cloth disposable diapers, have traditionally utilized absorbent structures which comprise entangled masses of fibers, i.e. non woven fibrous webs. These webs imbibe aqueous fluids, including discharged body fluids, both by an absorption mechanism where fluid is taken up by the fiber material itself, and especially by a wicking mechanism
20 where fluid is acquired by, distributed through and stored in the capillary interstices between the fibers. These webs often comprise loosely compacted, low density layers of absorbent fibers, such as carded cotton webs, air-laid cellulose fibers, comminuted wood pulp fibers, and the like. Fibrous webs used in such absorbent articles also often include certain absorbent gelling materials
25 usually referred to as "hydrogels", "super absorbent" or "hydrocolloid" materials to store large quantities of the discharged body fluids. Known technology to manufacture such cores includes air laying the fibers into shaped cavities on a screened drum to form the shape of the core and control the quantity of material used per core. Excess overflow of the shaped cavities is removed and returned to
30 the incoming air stream by a scarfing roll. The Absorbent Gelling Materials (AGM) are added to the airstream along with the fiber materials. This process allows for

many alternative shapes to be produced via changes in screen, laydown drum, configuration. Therefore the shape of the material is achieved via "molding" the fibers into shaped cavities. This process provides shape without trim, which in turn results in minimal scrap. Examples of such cores are disclosed in US-A-
5 4 673 402, issued 16th June 1987 and US-A-4 935 022, issued 19th June 1990.

An alternative absorbent material potentially capable of providing capillary fluid transport would be open-celled polymeric foams. If made appropriately, open-celled polymeric foams could provide features of capillary fluid acquisition,
10 transport and storage required for use in high performance absorbent cores for absorbent articles such as diapers. Absorbent articles containing such foams could possess desirable wet integrity, could provide suitable fit throughout the entire period the article is worn, and could avoid changes in shape during use. In addition, absorbent articles containing such foam structures could be easier to
15 manufacture on a commercial scale. For example, absorbent diaper cores could simply be stamped out of continuous foam sheets and could be designed to have considerably greater integrity and uniformity than air-laid fibrous absorbent cores containing particulate absorbent gelling materials.

20 Shaped or contoured absorbent cores made from open-celled foam materials are disclosed in US-A-5 147 345, issued 15th September 1992. This patent discloses absorbent cores comprising a fluid acquisition/distribution component that can be fibrous or foam based, as well as fluid
25 storage/redistribution component that comprises a hydrophilic, flexible, open-celled polymeric foam. Figure 9 discloses one such shaped or contoured core having an hourglass-shaped fluid redistribution/storage layer comprising an open-cell absorbent foam. Forming shaped or contoured absorbent cores or layers from foam materials is not without problems. The hourglass-shaped foam layer is typically made from a single rectangular piece of foam. This rectangular
30 piece of foam can be notched, cut or otherwise severed from the hourglass-shaped piece. In carrying out these operations, a significant amount of unusable

foam scrap can be created. Indeed it has been found that, in forming hourglass-shaped foam pieces, as much as 15% to 25% of the total foam material used can end up as unusable scrap.

5 The present invention relates to a process and apparatus for manufacturing an absorbent core having "zero scrap", thus eliminating the steps for disposing or recycling surplus material.

10 Figure 1 shows a perspective view of an apparatus 38 according to the present invention. The apparatus comprises a rotating drum 60. The drum 60 applies discrete first and second core elements 40a, 40b to a receiving web 1. In Figure 1 an incoming web 40 is fed to the apparatus 38 and is cut in a nested pattern (see, for example, Figure 5), and the discrete first and second core elements 40a, 40b of the incoming webs are held on vacuum shells 80a, 80b
15 which are arranged around the circumference of the rotating drum 60. The receiving web 1; the incoming web 40; and the cutting roll 39 are not shown in Figure 1 to simplify this illustration.

20 The drum 60 is rotated about a main axis of the apparatus. In the embodiment illustrated in Figures 1, 2, 3a and 3b the main axis is oriented horizontally, but this main axis need not necessarily be horizontal in all cases.

25 The vacuum shells 80a, 80b are mounted on rotatable shafts 81 and are rotatable about an axis A which is radial with respect to the drum 60. Alternate vacuum shells 80a, 80b are rotatable in mutually counter-rotating directions, preferably plus and minus 90° from the starting position. The means for providing the rotation each of the rotatable shafts 81 may suitably be provided by a rack and pinion arrangement, and a cam follower which runs around a shell turning
30 cam. The shell turning cam is shaped so that the rack and pinion operate to rotate alternate vacuum shells 80b through 90° during a first part of the cycle, prior to transfer of the second core element, 40b of the incoming web to the

receiving web 1, and then return the vacuum shells 80b to their original orientation by rotating them back through minus 90° during a second part of the cycle after the transfer.

5 In addition, during the first part of the cycle, a shell lifting cam acts to "lift" the vacuum shell 80b radially outwards from the drum 60. This action helps to apply the second core element 40b of the incoming web 40 to the receiving web 1 at a transfer step. During the second part of the cycle, after the cut core element 40b of the incoming web has been transferred to the receiving web 1,
10 the vacuum shells 80b are "withdrawn" radially inwards with respect to the drum 60. During the second part of the cycle, or subsequent to the second part of the cycle, the vacuum shells 80a (i.e. those vacuum shells which have not been rotated during the first part of the cycle) are rotated through minus 90° and are "lifted" radially outwards from the drum 60. This action helps to apply the first
15 core elements 40a of the incoming web 40 to the receiving web 1 at a transfer step. Finally the vacuum shells 80a are "withdrawn" radially inwards with respect to the drum 60, and the cycle is ready to repeat.

In the embodiment of the invention shown in Figures 1 and 2 the first and
20 second core elements 40a and 40b are rotated through plus 90° and minus 90° respectively in order to provide an hourglass-shaped core suitable for use in an absorbent article such as a diaper.

Typically, an absorbent article is assembled from an absorbent pad
25 element, or core which is encased between a liquid-pervious topsheet and a liquid impervious backsheet. In a preferred embodiment, the cores are comprised of airfelt or foam, within a cellulosic tissue envelope, to provide integrity to the core in use. The backsheet is coated on its inner surface with beads or spirals of adhesive, for affixing the backsheet to the core. Continuous bands of elastic are
30 fed from metering rolls past a glue nozzle. An S-wrap arrangement of the rolls feeding the bands of elastic minimises deformation of the elastic band and allows

for accurate control of the speed of the elastic. The elastic bands are fed into the direction of transport at a lower speed than the cores, the backsheet and the topsheet, so that the elastic bands are stretched.

5 In a particularly preferred embodiment of the present invention a receiving web (which may be, for example, either the backsheet or the topsheet) passes at a constant speed of transport to the infeed side 4 of an assembly 2 for periodically changing the speed of web (illustrated in Figure 4). In the assembly 2, the receiving web 1 can be slowed down, or stopped and is contacted by the
10 apparatus of the invention 38. The apparatus 38 comprises means for providing the core elements. The web 1 leaves the outfeed side 6 of the assembly 2 at the constant web speed. The speed of the receiving web portions located upstream and downstream from the assembly 2 along upstream trajectory 3 and downstream trajectory 5 is not affected by the change in speed of those parts of
15 the receiving web 1 that are passing through the assembly 2.

Figure 4 shows the assembly 2 for changing the speed of a flexible receiving web 1 of relatively low tear strength. By flexible, it is meant that the receiving web 1 can be transported along a curvilinear trajectory and will adapt its
20 shape so as to conform to the trajectory. The receiving web 1 is formed of flexible material, such as paper, airfelt, plastic etc. and can be comprised of the topsheet 121, the backsheet 123 or any combination thereof.

The receiving web 1 is transported along the upstream trajectory 3 with a
25 constant velocity of transport V_0 , in the machine direction F. The upstream trajectory 3 is formed by the length of the receiving web 1 which extends to the right of the first guide roller 9 in Figure 4, and which is moving towards the infeed side 4 of the assembly. After passing through the assembly, the receiving web 1 exits at the outfeed side 6 and is transported at constant velocity V_0 along the
30 downstream trajectory 5, which extends to the left of the guide roller 11. The

upstream and downstream trajectories need not correspond to the machine direction, and can be formed by straight-line or curvilinear paths.

5 The guide rollers 9 and 11 are rotationally connected to the frame 35. The guide rollers 9, 11 have a fixed position. The receiving web 1 is looped around an upstream and a downstream transport roller 13, 15 which are mounted on a sled 41. The sled 41 is cyclically translated along the frame 35, generally parallel to the machine direction F, by drive motor 36.

10 An intermediate trajectory 7a, 7b, 7c of the receiving web 1 is located between the upstream guide roller 9 and the downstream guide roller 11, and comprises a first section 7a and a third section 7c, of variable length, located between the upstream guide roller 9 and the upstream transport roller 13 and the downstream transport roller 15 and the downstream guide roller 11 respectively.
15 The second section 7c of the intermediate trajectory 7 is located between the transport rollers 13 and 15 and is of constant length.

Because of the symmetry of the intermediate trajectory 7a, 7b, 7c, the increase in length of the first section 7a, upon displacement of the sled 41
20 opposite to the machine direction F and away from the equilibrium position 39, is compensated by an equal decrease in length of the third section 7c, and vice versa. As the length of the second section 7b is constant, the whole intermediate trajectory 7a, 7b, 7c is independent of the position of the sled 41 with respect to the frame 35.

25

When the part of the receiving web that is located along the second section 7b of the intermediate trajectory 7a, 7b, 7c, is stationary (or at least it is slower than the speed of the web speed V_0) relative to the frame 35, the web 1 is contacted by the applicator means 38 which is positionally stationary (or at least
30 slower) with respect to the frame 35. After the apparatus 38 has interacted with the receiving web 1, the web is accelerated along the section 7b of the

intermediate trajectory towards the outfeed side 6 of the assembly 2, and is supplied to the downstream trajectory 5 with web speed V_0 .

5 The guide rollers 9, 11 and the transport rollers 13, 15 are driven by a drive member in the form of a closed loop 50 and pulleys 52, 53 and 54. The loop 50 is partly parallel to the intermediate trajectory 7a, 7b, 7c. The loop 50 is driven at a constant speed which is equal to the speed of transport V_0 , of the web 1 by a single drive motor 51. By driving the guide rollers 9, 11 and the transport rollers 13, 15, the strain exerted on the web 1 is minimised and can be limited to the
10 acceleration forces, which are acting to change the speed of the web. Further details of suitable assembly are disclosed in EP-A-0 652 175, published on 10th May 1995.

Figure 5 shows a web 40 which has been cut into discrete core elements
15 40a, 40b. Second core elements 40b are subsequently rotated about their axis A.

The first and second core elements 40a, 40b are either mutually adhered, or are adhered to the receiving web 1, or both. This may be done using any conventional method such as by gluing with adhesives, such as melt adhesives,
20 or use of self-adhesive components, or by use of ultrasonic welding, heat sealing or the like.

WHAT IS CLAIMED IS:

1. A process for the manufacture of disposable absorbent cores from a continuous web (40), wherein a plurality of first and second core elements
5 (40a, 40b), are cut from the same continuous web (40),
characterised in that the absorbent core is formed by rotating each of first and second core elements (40a, 40b) about axes (A) perpendicular to the plane of the core element (40a, 40b) and subsequently combining a first core element (40a) and a second core element (40b) in proximal
10 relationship to form the absorbent core.
2. A process according to claim 1 wherein each of the first and second core elements (40a, 40b) are rotated through 90° in mutually counter-rotating directions.
- 15 3. A process according to either of claims 1 or 2 wherein the continuous web (40) is made from air-laid fibers or foam, most preferably foam.
4. A process according to any of claims 1 to 3 wherein a receiving web (1) is
20 fed relative to a stationary frame (35) along an upstream trajectory (3), a downstream trajectory (5), and an intermediate trajectory (7a, 7b, 7c) comprised between the upstream trajectory (3) and the downstream trajectory (5), the web (1) having along the upstream trajectory (3) and along the downstream trajectory (5) a substantially constant speed of
25 transport, wherein the receiving web (1) runs along an upstream and a downstream guide roller (9, 11) that are translationally stationary relative to the frame (35) and along an upstream and downstream transport roller (13, 15) that are periodically displaced relative to the guide rollers (9, 11) around a transfer position (39), and wherein the discrete core elements (40a, 40b)
30 are applied to the receiving web (1) when it is at the transfer position.

5. A process according to claim 4 wherein the periodic displacement of the transport rollers (13, 15) around the transfer position occurs at a frequency of between 1 Hz and 100 Hz, preferably between 1Hz and 10 Hz.
- 5 6. A process according to any of the previous claims wherein the receiving web (1) comprises either a liquid-pervious topsheet or a liquid impervious backsheet.
- 10 7. An apparatus (38) for the manufacture of disposable absorbent cores from a continuous web (40), wherein the apparatus comprises a means for cutting a plurality of first and second core elements (40a, 40b) from the same continuous web (40),
characterised in that the apparatus further comprises means of forming the absorbent core by rotating each of first and second core elements (40a,
15 40b) about axes (A) perpendicular to the plane of the core element (40a, 40b) and subsequently combining a first core element (40a) and a second core element (40b) in proximal relationship to form the absorbent core.
- 20 8. An apparatus (38) according to claim 7 comprising a rotating drum (60) to apply discrete first and second core elements (40a, 40b) to a receiving web (1), and further comprising vacuum shells (80a, 80b) which are arranged around the circumference of the rotating drum (60).
- 25 9. An apparatus (38) according to claim 8 wherein each of the vacuum shells (80b) are rotatable about an axis (A) perpendicular to the plane of the core elements (40a, 40b), preferably by means of rack and pinion (82, 83).

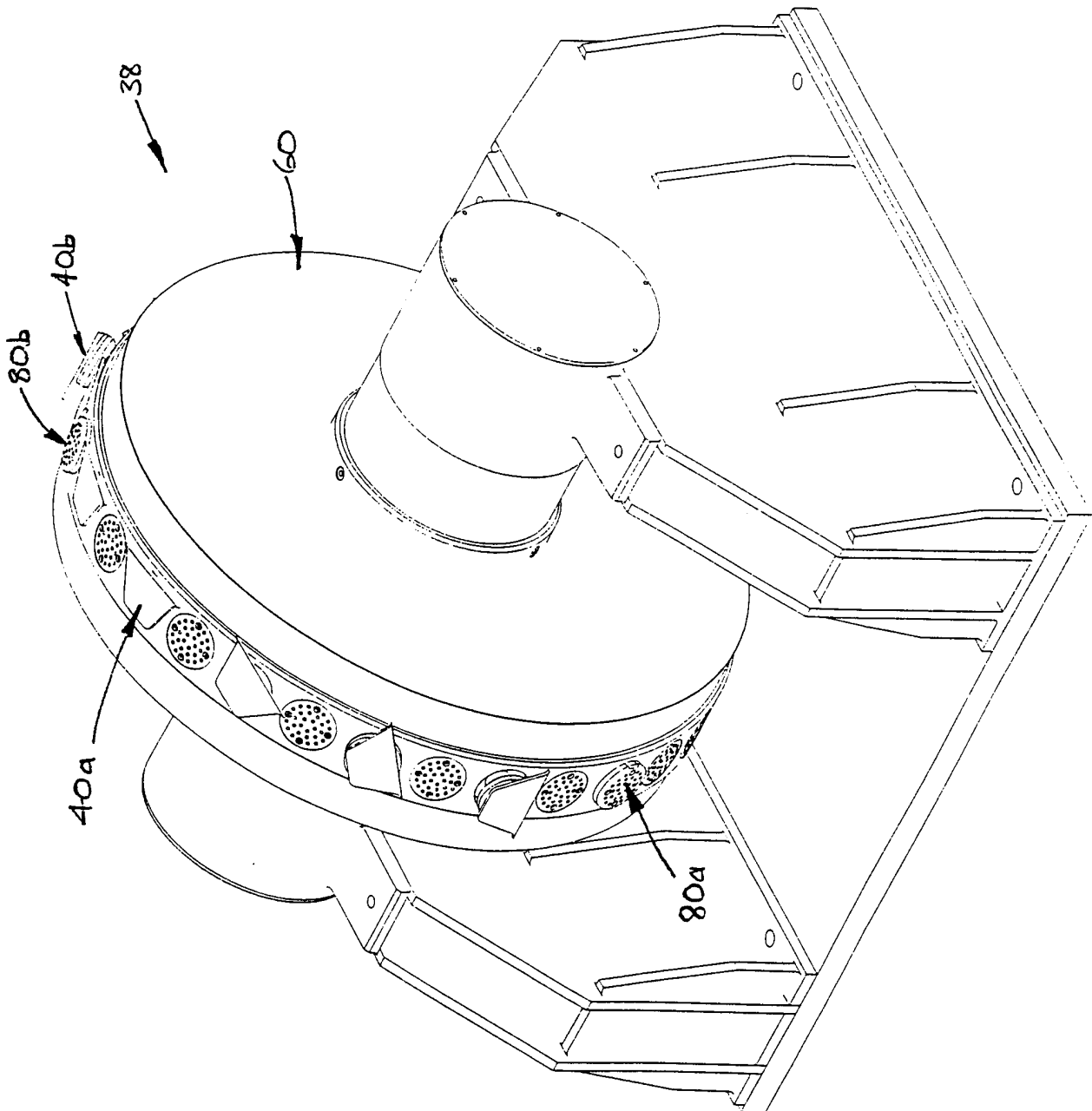

Fig 1

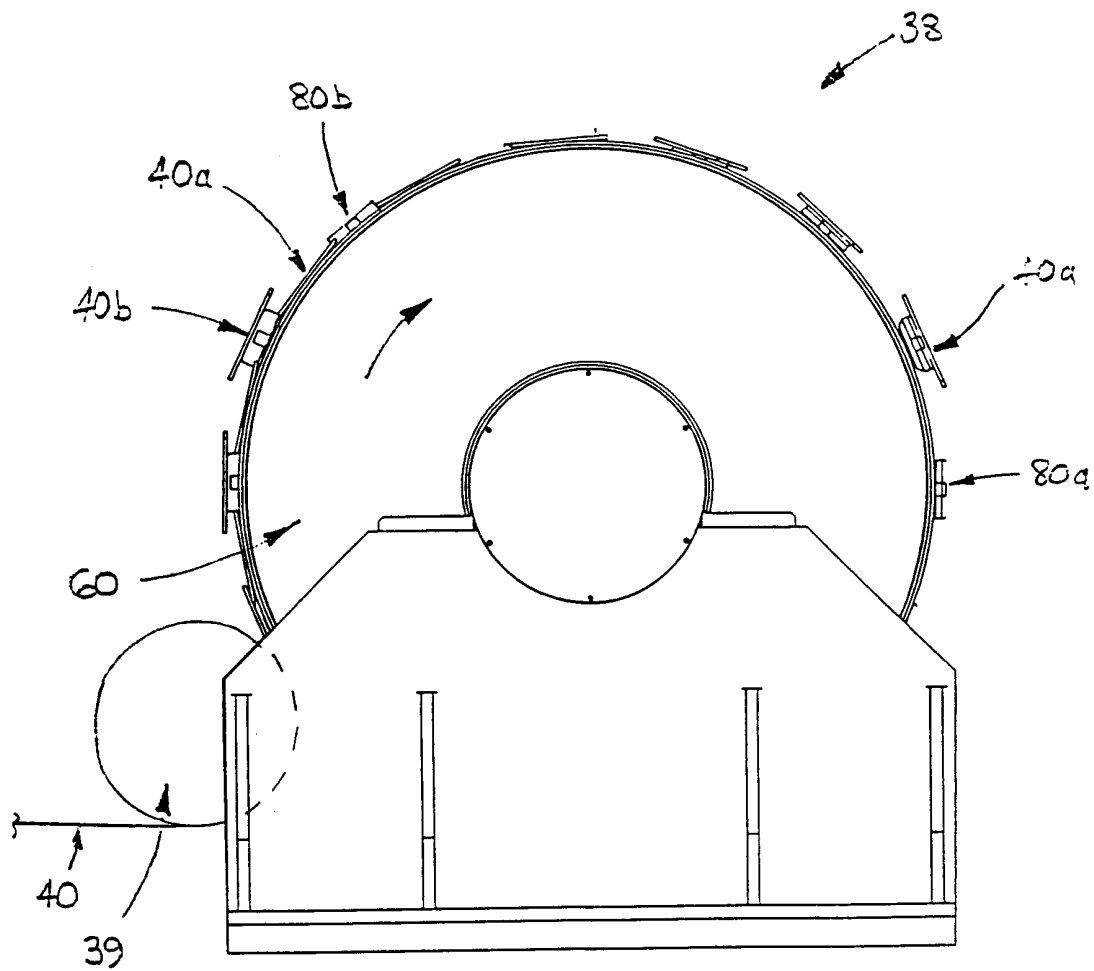

Fig 2

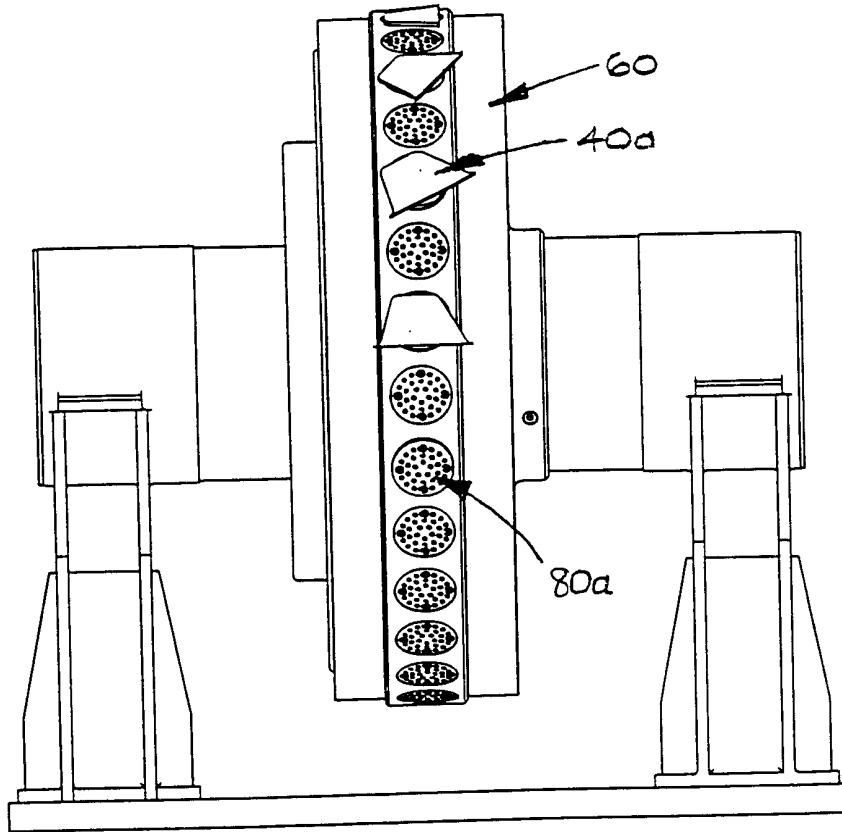

Fig 3a

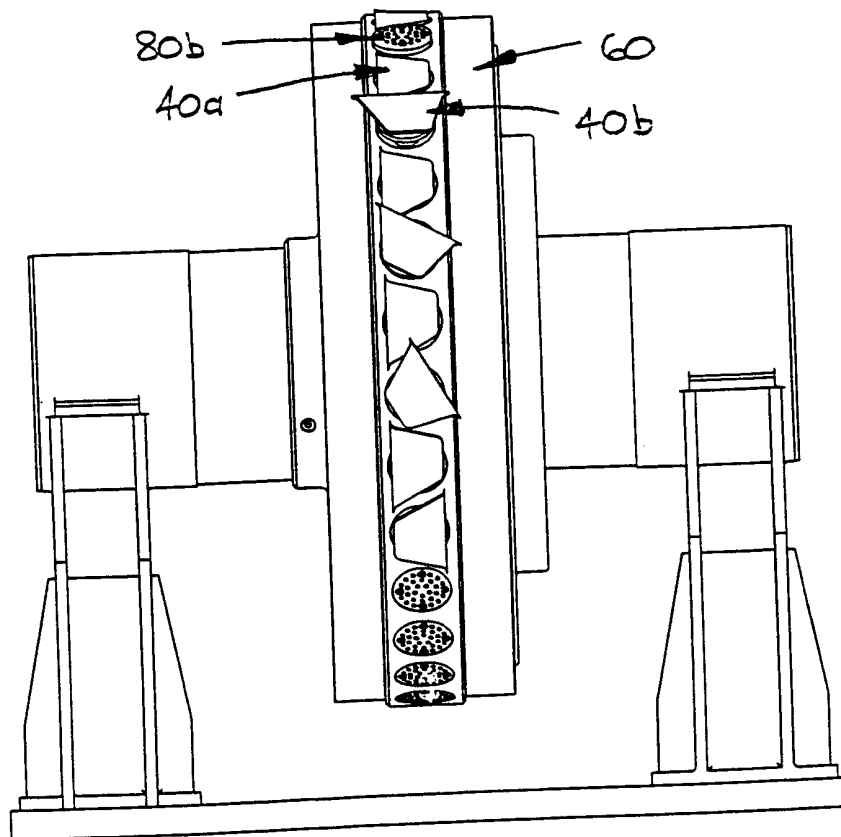

Fig 3b

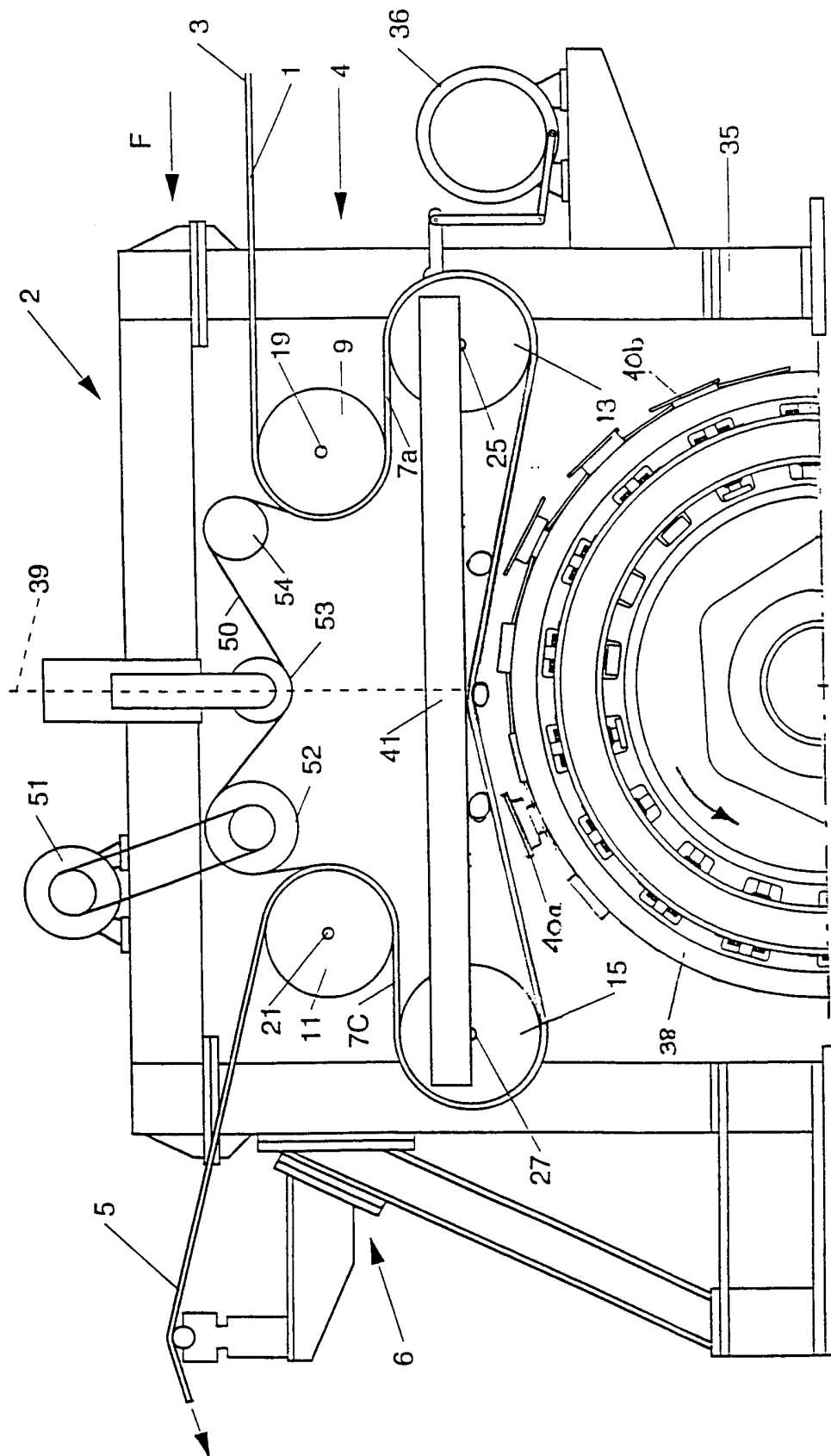

Fig 4

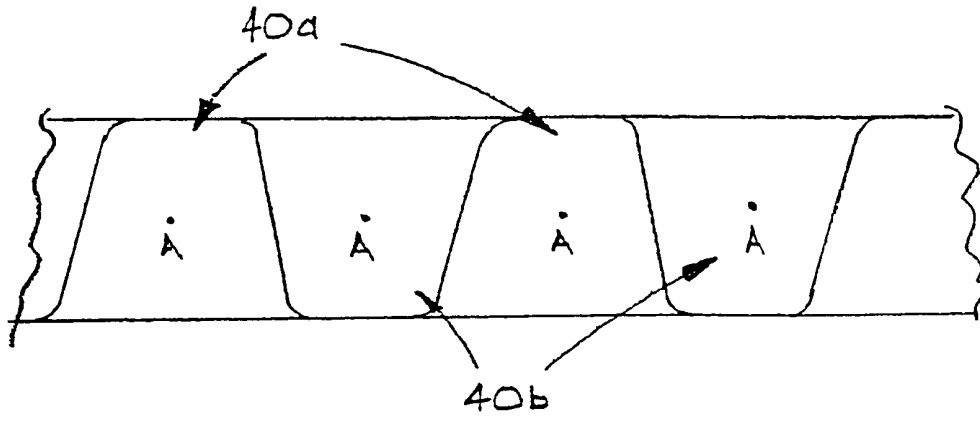

Fig 5a

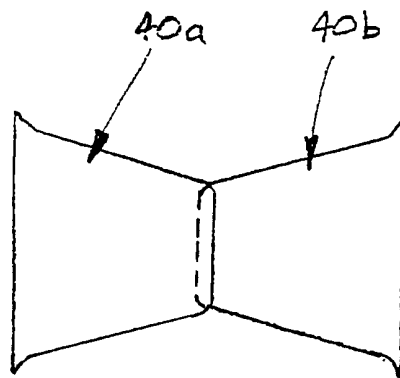

Fig 5b

INTERNATIONAL SEARCH REPORT

International Application No

PCT/US 00/17500

A. CLASSIFICATION OF SUBJECT MATTER

IPC 7 A61F13/15

According to International Patent Classification (IPC) or to both national classification and IPC

B. FIELDS SEARCHED

Minimum documentation searched (classification system followed by classification symbols)

IPC 7 A61F

Documentation searched other than minimum documentation to the extent that such documents are included in the fields searched

Electronic data base consulted during the international search (name of data base and, where practical, search terms used)

WPI Data, PAJ, EPO-Internal

C. DOCUMENTS CONSIDERED TO BE RELEVANT

Category *	Citation of document, with indication, where appropriate, of the relevant passages	Relevant to claim No.
A	US 5 660 665 A (JALONEN ALVIN CHARLES) 26 August 1997 (1997-08-26) abstract; claims; figures 2,3A,3B ---	1-9
A	US 5 584 954 A (VAN DER KLUGT WALTER P H L) 17 December 1996 (1996-12-17) ---	
A	WO 96 21411 A (PROCTER & GAMBLE) 18 July 1996 (1996-07-18) cited in the application ---	
A	EP 0 652 175 A (PROCTER & GAMBLE) 10 May 1995 (1995-05-10) cited in the application ---	
A	US 4 760 764 A (DE JONCKHEERE RAPHAEL ET AL) 2 August 1988 (1988-08-02) cited in the application ---	
-/--		

Further documents are listed in the continuation of box C.

Patent family members are listed in annex.

* Special categories of cited documents :

- *A* document defining the general state of the art which is not considered to be of particular relevance
- *E* earlier document but published on or after the international filing date
- *L* document which may throw doubts on priority claim(s) or which is cited to establish the publication date of another citation or other special reason (as specified)
- *O* document referring to an oral disclosure, use, exhibition or other means
- *P* document published prior to the international filing date but later than the priority date claimed

- *T* later document published after the international filing date or priority date and not in conflict with the application but cited to understand the principle or theory underlying the invention
- *X* document of particular relevance; the claimed invention cannot be considered novel or cannot be considered to involve an inventive step when the document is taken alone
- *Y* document of particular relevance; the claimed invention cannot be considered to involve an inventive step when the document is combined with one or more other such documents, such combination being obvious to a person skilled in the art.
- *&* document member of the same patent family

Date of the actual completion of the international search

9 October 2000

Date of mailing of the international search report

16/10/2000

Name and mailing address of the ISA

European Patent Office, P.B. 5818 Patentlaan 2
NL - 2280 HV Rijswijk
Tel. (+31-70) 340-2040, Tx. 31 651 epo nl,
Fax: (+31-70) 340-3016

Authorized officer

Soederberg, J

INTERNATIONAL SEARCH REPORT

International Application No
PCT/US 00/17500

C.(Continuation) DOCUMENTS CONSIDERED TO BE RELEVANT		
Category *	Citation of document, with indication, where appropriate, of the relevant passages	Relevant to claim No.
A	US 5 147 345 A (YOUNG GERALD A ET AL) 15 September 1992 (1992-09-15) cited in the application ---	
A	US 4 673 402 A (GELLERT DALE A ET AL) 16 June 1987 (1987-06-16) cited in the application -----	

INTERNATIONAL SEARCH REPORT

Information on patent family members

International Application No

PCT/US 00/17500

Patent document cited in search report	Publication date	Patent family member(s)	Publication date
US 5660665 A	26-08-1997	AU 1079297 A	14-07-1997
		CA 2238445 A	26-06-1997
		WO 9722317 A	26-06-1997
US 5584954 A	17-12-1996	US 5396978 A	14-03-1995
		AU 7409994 A	28-02-1995
		CA 2168777 A,C	16-02-1995
		DE 69411169 D	23-07-1998
		DE 69411169 T	17-12-1998
		EP 0708736 A	01-05-1996
		ES 2117287 T	01-08-1998
		HK 1012837 A	06-08-1999
		JP 9501644 T	18-02-1997
		WO 9504695 A	16-02-1995
		WO 9621411 A	18-07-1996
AT 195859 T	15-09-2000		
AU 4655696 A	31-07-1996		
BR 9606972 A	04-11-1997		
CA 2207259 A	18-07-1996		
CN 1176590 A	18-03-1998		
DE 69610070 D	05-10-2000		
EG 20678 A	30-11-1999		
EP 0801551 A	22-10-1997		
JP 10512170 T	24-11-1998		
US 5695846 A	09-12-1997		
ZA 9600224 A	09-07-1996		
EP 0652175 A	10-05-1995		
		AU 8126394 A	23-05-1995
		CA 2175555 A	11-05-1995
		DE 69316625 D	26-02-1998
		DE 69316625 T	18-06-1998
		DK 652175 T	16-03-1998
		ES 2111696 T	16-03-1998
		GR 3026029 T	30-04-1998
		HK 1008739 A	14-05-1999
		JP 9504459 T	06-05-1997
		WO 9512491 A	11-05-1995
		US 5693165 A	02-12-1997
		US 4760764 A	02-08-1988
AT 55239 T	15-08-1990		
DE 3673311 D	13-09-1990		
EP 0218857 A	22-04-1987		
ES 2001245 A	01-05-1988		
JP 62250202 A	31-10-1987		
US 5147345 A	15-09-1992	AT 149824 T	15-03-1997
		AU 669667 B	20-06-1996
		AU 2460892 A	16-03-1993
		BR 9206373 A	25-04-1995
		CA 2114957 A	04-03-1993
		CN 1074110 A	14-07-1993
		CZ 9400303 A	13-07-1994
		DE 69218219 D	17-04-1997
		DE 69218219 T	10-07-1997
		DK 598823 T	21-04-1997

INTERNATIONAL SEARCH REPORT

Information on patent family members

International Application No

PCT/US 00/17500

Patent document cited in search report	Publication date	Patent family member(s)	Publication date	
US 5147345	A	EG 19687 A	31-10-1995	
		EP 0598823 A	01-06-1994	
		ES 2099831 T	01-06-1997	
		FI 940650 A	11-02-1994	
		GR 3022800 T	30-06-1997	
		HK 1006530 A	05-03-1999	
		HU 71533 A	28-12-1995	
		JP 6509729 T	02-11-1994	
		KR 226396 B	15-10-1999	
		MX 9204675 A	01-03-1993	
		NO 940451 A	11-04-1994	
		NZ 243904 A	26-09-1995	
		PL 169450 B	31-07-1996	
		PT 8582 U	31-05-1993	
		PT 101751 A, B	31-01-1996	
		RU 2125860 C	10-02-1999	
		SG 48921 A	18-05-1998	
		SK 18194 A	07-12-1994	
		TR 26574 A	15-03-1995	
		WO 9303699 A	04-03-1993	
		US 5652194 A	29-07-1997	
US 5649920 A	22-07-1997			
US 5318554 A	07-06-1994			
US 5387207 A	07-02-1995			
US 4673402	A	16-06-1987	AT 78151 T	15-08-1992
			AU 578402 B	20-10-1988
			AU 5741786 A	20-11-1986
			CA 1262814 A	14-11-1989
			DE 3685986 A	20-08-1992
			DE 3685986 T	17-12-1992
			DK 226286 A	16-11-1986
			EP 0202125 A	20-11-1986
			ES 294162 U	01-11-1987
			FI 862010 A, B,	16-11-1986
			GB 2175212 A, B	26-11-1986
			GR 861236 A	28-08-1986
			HK 10592 A	31-01-1992
			IE 57959 B	19-05-1993
			JP 7024672 B	22-03-1995
			JP 62032950 A	12-02-1987
			KR 9400805 B	02-02-1994
			MX 168820 B	10-06-1993
			PH 23956 A	23-01-1990
			PT 82573 A, B	01-06-1986
			SG 102791 G	17-01-1992
ZA 8603563 A	27-07-1988			