



(19) **United States**

(12) **Patent Application Publication**

Kim et al.

(10) **Pub. No.: US 2016/0099740 A1**

(43) **Pub. Date: Apr. 7, 2016**

(54) **CASING, PORTABLE ELECTRONIC ASSEMBLY HAVING THE SAME AND DISPLAY METHOD THEREOF**

H05K 5/02 (2006.01)

G06F 1/16 (2006.01)

(52) **U.S. Cl.**

CPC *H04B 1/3888* (2013.01); *G06F 1/166* (2013.01); *G06F 1/1686* (2013.01); *H05K 5/0017* (2013.01); *H05K 5/0234* (2013.01)

(71) Applicant: **HTC Corporation**, Taoyuan City (TW)

(72) Inventors: **Catherine Sayim Kim**, San Francisco, CA (US); **Maxence Sylvain Marie Joseph Derreumaux**, San Francisco, CA (US); **Chi Jen Lu**, San Francisco, CA (US)

(57)

ABSTRACT

A casing applicable to a portable electronic device includes a supporter and a casing body having a back surface and side surfaces connecting to the back surface. The back surface has a camera opening for exposing a camera shutter of the portable electronic device and a supporter opening having a bevel side not parallel to the side surfaces. The supporter connected to the bevel side includes first and second sides which define a vertex angle. The supporter is adapted to rotate between a covering position and a supporting position. When at the covering position, the supporter covers the supporter opening, and the vertex angle and the camera opening are arranged diagonally. When the supporter is at the supporting position, the casing is supported by the vertex angle and one of the side surfaces away from the camera opening for the portable electronic device to perform landscape or portrait display.

(21) Appl. No.: **14/835,731**

(22) Filed: **Aug. 26, 2015**

Related U.S. Application Data

(60) Provisional application No. 62/060,591, filed on Oct. 7, 2014.

Publication Classification

(51) **Int. Cl.**

H04B 1/3888 (2006.01)

H05K 5/00 (2006.01)

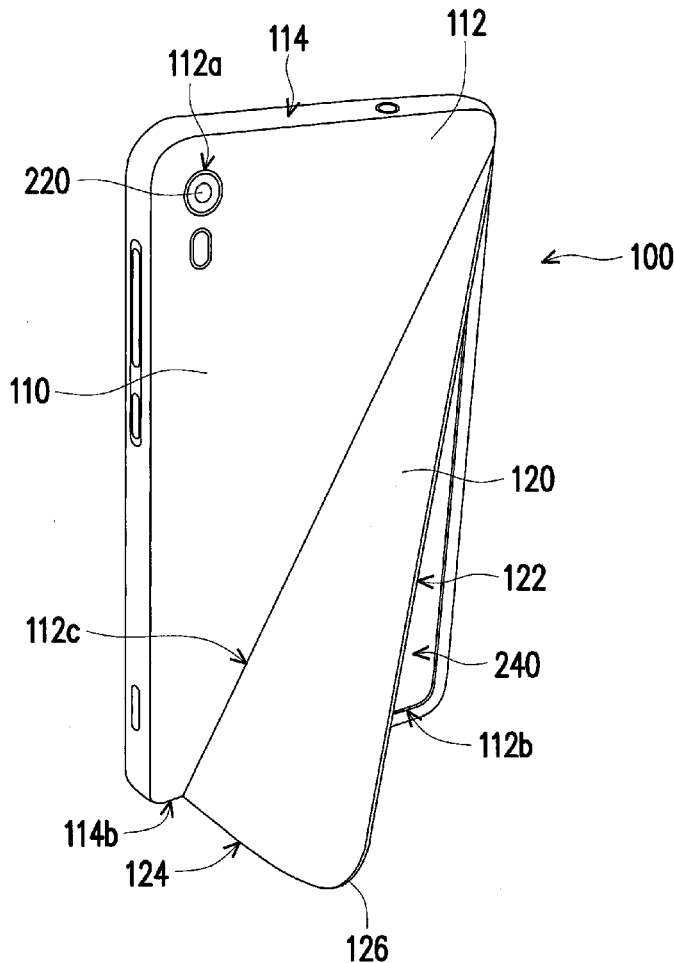

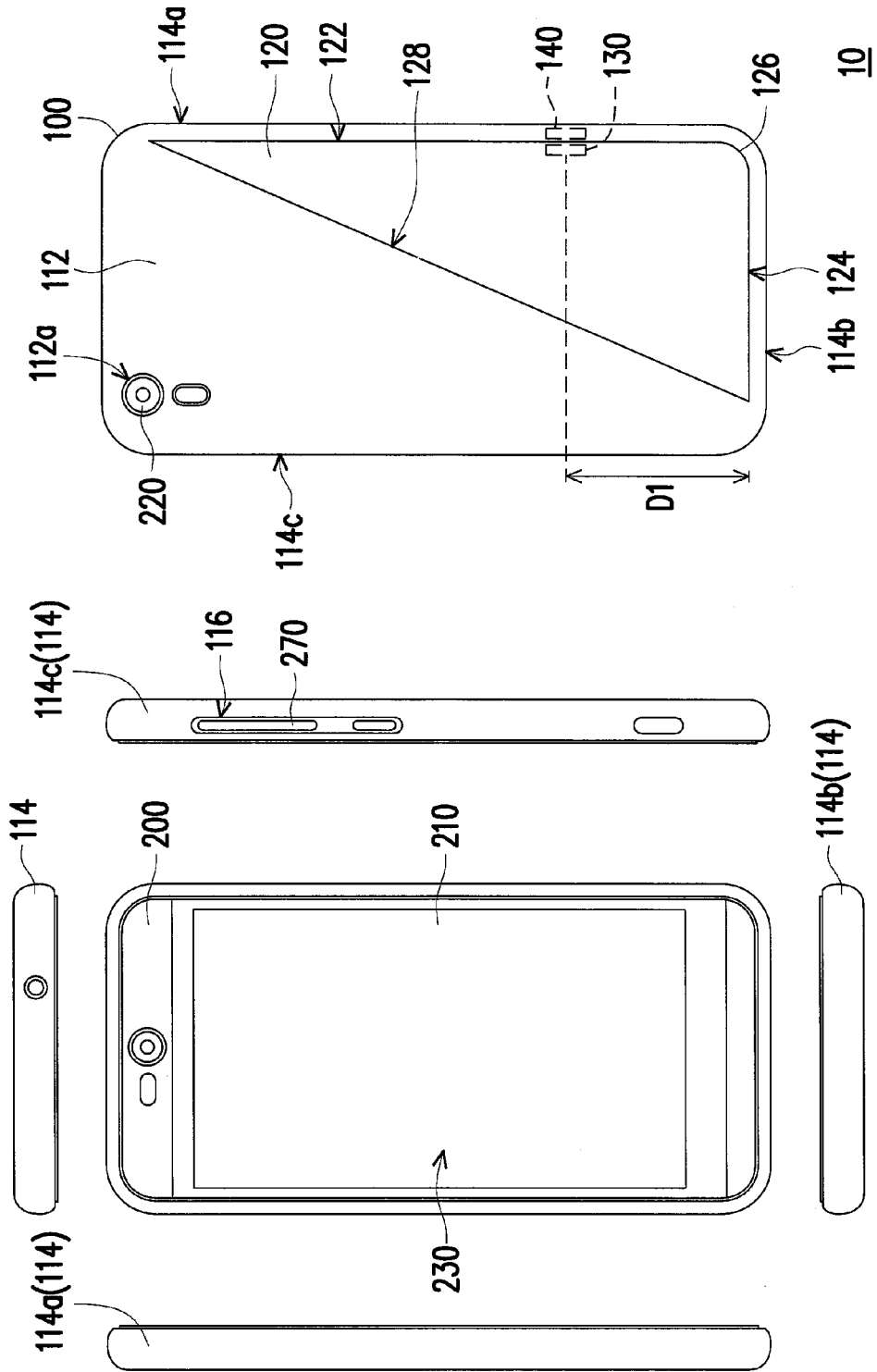

FIG. 1

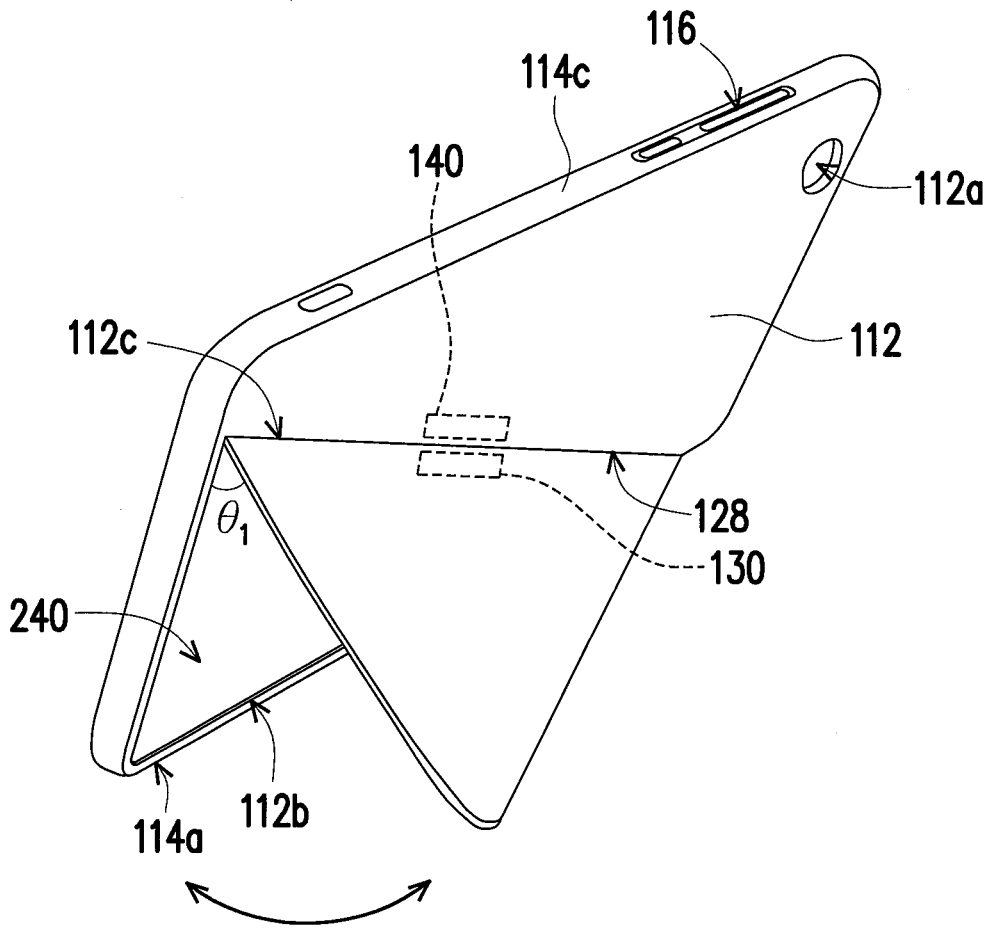

FIG. 2

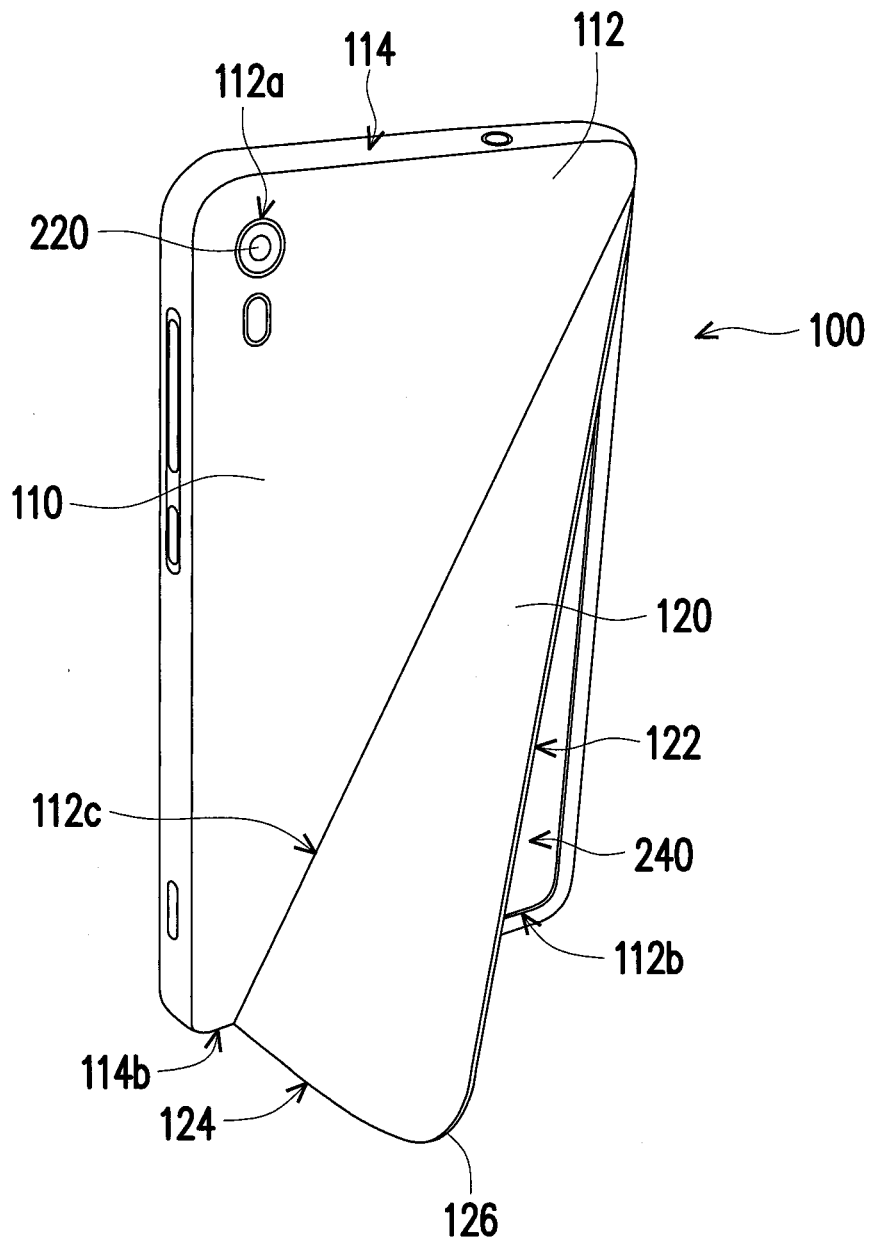

FIG. 3

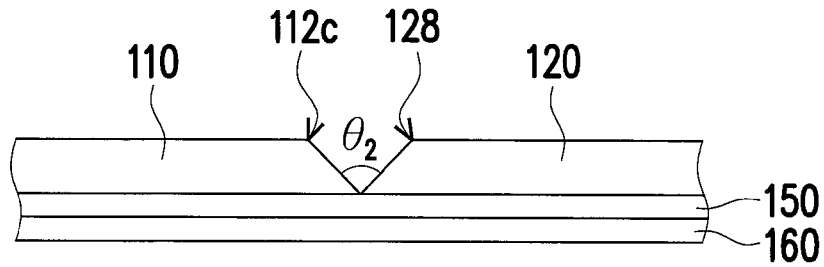

FIG. 4

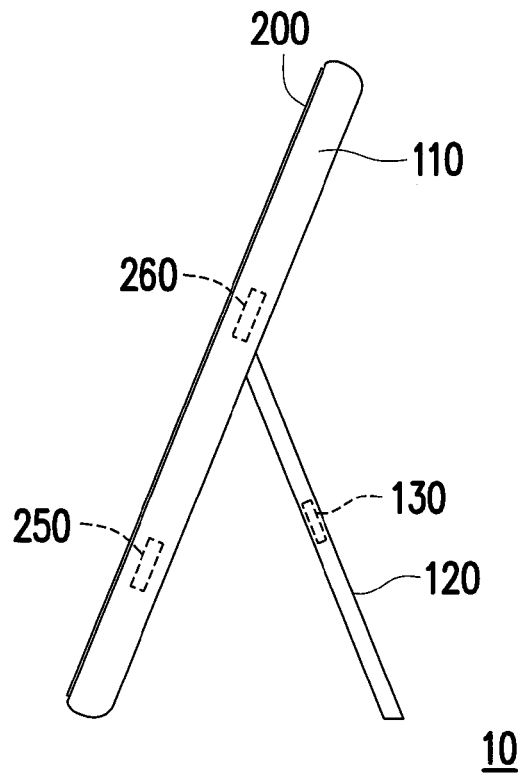

FIG. 5

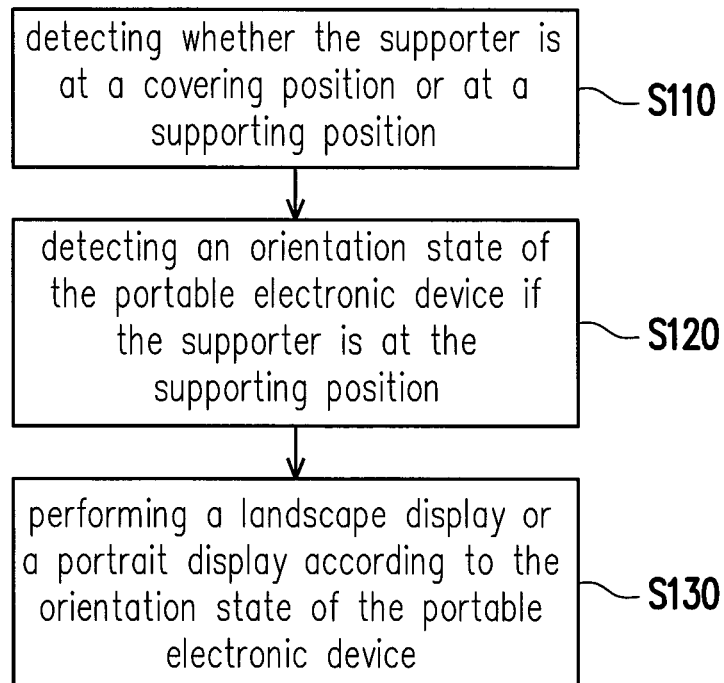

FIG. 6

**CASING, PORTABLE ELECTRONIC
ASSEMBLY HAVING THE SAME AND
DISPLAY METHOD THEREOF**

**CROSS-REFERENCE TO RELATED
APPLICATION**

[0001] This application claims the priority benefits of U.S. provisional application Ser. No. 62/060,591, filed on Oct. 7, 2014. The entirety of the above-mentioned patent application is hereby incorporated by reference herein and made a part of this specification.

BACKGROUND OF THE INVENTION

[0002] 1. Field of the Invention

[0003] The present invention generally relates to a casing, a portable electronic assembly and a display method. More particularly, the present invention relates to a casing, a portable electronic assembly having the casing and a display method of the portable electronic assembly.

[0004] 2. Description of Related Art

[0005] Portable electronic devices are suitable to be carried by a user. However, a portable electronic device may be damaged due to be bumped or hit, or wear down the outer casing, when being carried. In order to avoid damage, a protective cover is generally used to cover the portable electronic device for protection.

[0006] In addition, when viewing some information on a portable electronic device such as a tablet PC, the portable electronic device is usually disposed on a supporter with a suitable angle for the user to use. Thus, not only a protective cover is required, but also a supporter, thus to improve the convenience while using. However, buying and carrying multiple items is a burden for the user.

SUMMARY OF THE INVENTION

[0007] Accordingly, the present invention is directed to a casing which is capable of covering and protecting a portable electronic device and also supporting the portable electronic device with a suitable angle for the user to use.

[0008] The present invention is directed to a portable electronic assembly having the above-mentioned casing.

[0009] The present invention is further directed to a display method of the above-mentioned portable electronic assembly for the portable electronic device to display in landscape mode or portrait mode.

[0010] The present invention provides a casing applicable to a portable electronic device. The casing includes a casing body and a supporter. The casing body includes a back surface and a plurality of side surfaces connecting to the back surface. The back surface has a camera opening for exposing a camera shutter of the portable electronic device and a supporter opening having a bevel side not parallel to any of the side surfaces. The supporter is connected to the bevel side and includes a first side and a second side, wherein the first side and the second side define a vertex angle. The supporter is adapted to rotate about the bevel side between a covering position and a supporting position. When the supporter is at the covering position, the supporter covers the supporter opening, and the vertex angle and the camera opening are arranged diagonally. When the supporter is at the supporting position, the casing is supported by the vertex angle and one of the side surfaces away from the camera opening for the portable electronic device to perform a landscape display or a portrait display.

[0011] The present invention provides a portable electronic assembly. The portable electronic assembly includes a portable electronic device and a casing. The portable electronic device includes a display, a camera shutter, a first surface and a second surface opposite to the first surface, wherein the display is disposed on the first surface and the camera shutter is disposed on the second surface. The casing partially covers the portable electronic device and exposes the first surface. The casing includes a casing body and a supporter. The casing body includes a back surface and a plurality of side surfaces connecting to the back surface. The back surface has a camera opening for exposing the camera shutter and a supporter opening having a bevel side not parallel to any of the side surfaces. The supporter is connected to the bevel side and includes a first side and a second side, wherein the first side and the second side define a vertex angle. The supporter is adapted to rotate about the bevel side between a covering position and a supporting position. When the supporter is at the covering position, the supporter covers the supporter opening, and the vertex angle and the camera opening are arranged diagonally. When the supporter is at the supporting position, the portable electronic device is supported by the vertex angle and one of the side surfaces away from the camera opening to perform a landscape display or a portrait display.

[0012] The present invention further provides a display method of a portable electronic assembly, wherein the portable electronic assembly includes a portable electronic device and a casing partially covering the portable electronic device and including a casing body and a supporter. The method includes the following steps. Firstly, whether the supporter is at a covering position for covering the portable electronic device or at a supporting position for supporting the portable electronic device via the first side or the second side of the supporter is detected. Next, an orientation state of the portable electronic device is detected if the supporter is at the supporting position. Then, a landscape display or a portrait display is performed according to the orientation state of the portable electronic device.

[0013] Based on the description above, the casing of the present invention is configured for partially covering a portable electronic device to form a portable electronic assembly therewith. The casing includes a supporter adapted to rotate relatively to the casing body to be at a covering position and a supporting position. When the supporter is at the covering position, the supporter covers and protects the portable electronic device, and when the supporter is at the supporting position, the portable electronic device is supported by the supporter to perform a landscape display or a portrait display. Therefore, the casing of the present invention is capable of covering and protecting the portable electronic device and also supporting the portable electronic device with a suitable angle for a user to use.

[0014] In addition, a display method for the portable electronic assembly having the casing and the portable electronic device is also developed. When the first sensor detects the supporter being at the supporting position, the orientation state of the portable electronic device is detected. Accordingly, the portable electronic device determines to perform a landscape display or a portrait display according to the orientation state of the portable electronic device. Therefore, the portable electronic assembly can automatically perform a landscape display or a portrait display according to the posi-

tion of the supporter and the orientation state of the portable electronic device, which further increases the convenience in use.

BRIEF DESCRIPTION OF THE DRAWINGS

[0015] The accompanying drawings are included to provide a further understanding of the invention, and are incorporated in and constitute a part of this specification. The drawings illustrate embodiments of the invention and, together with the description, serve to explain the principles of the invention.

[0016] FIG. 1 illustrates 6-sided views of a portable electronic assembly according to an exemplary embodiment.

[0017] FIG. 2 illustrates a schematic view of the portable electronic assembly in a landscape display according to an exemplary embodiment.

[0018] FIG. 3 illustrates a schematic view of the portable electronic assembly in a portrait display according to an exemplary embodiment.

[0019] FIG. 4 illustrates a partial cross-sectional view of the casing at a covering position according to an exemplary embodiment.

[0020] FIG. 5 illustrates a side view of the portable electronic assembly at a supporting position according to an exemplary embodiment.

[0021] FIG. 6 illustrates a flow chart of a display method of a portable electronic assembly according to an exemplary embodiment.

DESCRIPTION OF THE EMBODIMENTS

[0022] In the following detailed description of the preferred embodiments, reference is made to the accompanying drawings which form a part hereof, and in which are shown by way of illustration specific embodiments in which the invention may be practiced. In this regard, directional terminology, such as “top”, “bottom”, “front”, or “back”, etc., is used with reference to the orientation of the Figure(s) being described. The components of the present invention can be positioned in a number of different orientations. As such, the directional terminology is used for purposes of illustration and is in no way limiting. On the other hand, the drawings are only schematic and the sizes of components may be exaggerated for clarity. It is to be understood that other embodiments may be utilized and structural changes may be made without departing from the scope of the present invention. Also, it is to be understood that the phraseology and terminology used herein are for the purpose of description and should not be regarded as limiting. The use of “including,” “comprising,” or “having” and variations thereof herein is meant to encompass the items listed thereafter and equivalents thereof as well as additional items. Unless limited otherwise, the terms “connected,” “coupled,” and “mounted” and variations thereof herein are used broadly and encompass direct and indirect connections, couplings, and mountings. Similarly, the terms “facing,” “faces” and variations thereof herein are used broadly and encompass direct and indirect facing, and “adjacent to” and variations thereof herein are used broadly and encompass directly and indirectly “adjacent to.” Therefore, the description of “A” component facing “B” component herein may contain the situations that “A” component directly faces “B” component or one or more additional components are between “A” component and “B” component. Also, the description of “A” component “adjacent to” “B” component

herein may contain the situations that “A” component is directly “adjacent to” “B” component or one or more additional components are between “A” component and “B” component. Accordingly, the drawings and descriptions will be regarded as illustrative in nature and not as restrictive.

[0023] Reference will now be made in detail to the present preferred embodiments of the invention, examples of which are illustrated in the accompanying drawings. Wherever possible, the same reference numbers are used in the drawings and the description to refer to the same or like parts.

[0024] FIG. 1 illustrates 6-sided views of a casing according to an exemplary embodiment. FIG. 2 illustrates a schematic view of the portable electronic assembly in FIG. 1 in a landscape display. FIG. 3 illustrates a schematic view of the portable electronic assembly in FIG. 1 in a portrait display. Firstly referring to FIG. 1 and FIG. 2, in the present embodiment, a portable electronic assembly 10 includes a casing 100 and a portable electronic device 200. The casing 100 is applicable to the portable electronic device 200 for partially covering and protecting the portable electronic device 200. The portable electronic device 200 includes a display 210, a camera shutter 220, a first surface 230 and a second surface 240 opposite to the first surface 230. The display 210 is disposed on the first surface 230 and the camera shutter 220 is disposed on the second surface 240. The casing 100 partially covers the portable electronic device 200 and exposes the first surface 230 and the display 210 as shown in FIG. 1.

[0025] In detail, the casing 100 includes a casing body 110 and a supporter 120. The casing body 110 includes a back surface 112 and a plurality of side surfaces 114 connecting to the back surface 112. The back surface 112 has a camera opening 112a and a supporter opening 112b. The camera opening 112a is configured for exposing the camera shutter 220 of the portable electronic device 200. The supporter opening 112b has a bevel side 112c as shown in FIG. 2 which is not parallel to any of the side surfaces 114. The supporter 120 is connected to the bevel side 112c and includes a first side 122 and a second side 124 which together define a vertex angle 126 as shown in FIG. 1. The supporter 120 is adapted to rotate about the bevel side 112c, so as to rotate between a covering position as shown in FIG. 1 and a supporting position as shown in FIG. 2 and FIG. 3.

[0026] In the present embodiment, when the supporter 120 is at the covering position as shown in FIG. 1, the supporter 120 covers the supporter opening 112b for covering and protecting the portable electronic device 200. Also, when the supporter 120 is at the covering position, the vertex angle 126 and the camera opening 112a are arranged diagonally, so the supporter 120 would not interfere with the operation of the camera shutter 220. When the supporter 120 is at the supporting position as shown in FIG. 2 and FIG. 3, the casing 100 and the portable electronic device 200 are supported by the vertex angle 126 and one of the side surfaces 114 away from the camera opening 112a for the portable electronic device 200 to perform a landscape display as shown in FIG. 2 or a portrait display as shown in FIG. 3.

[0027] To be more specific, when the portable electronic device 200 is supported by the vertex angle 126 and the side surface 114a as shown in FIG. 1, the portable electronic device 200 is adapted to perform a landscape display as shown in FIG. 2. When the portable electronic device 200 is supported by the vertex angle 126 and the side surface 114b as shown in FIG. 1, the portable electronic device 200 is adapted to perform a portrait display as shown in FIG. 3. It is noted

that the side surfaces **114a** and **114b** are, for example, the side surfaces away from the camera opening **112a**, such that when being at the supporting position as shown in FIG. 2 and FIG. 3, the supporter **120** would not interfere the operation of the camera shutter **220**.

[0028] In addition, the casing body **110** may further include a bottom opening **116** for exposing, for example, a volume-control bottom **270** of the portable electronic device **200**. In the present embodiment, the bottom opening **116** is disposed at one of the side surfaces **114** which is adjacent to the camera opening **112a**. Specifically, the bottom opening **116** is disposed at the side surface **114c** as shown in FIG. 1. As such, when the portable electronic device **200** is supported by the supporter **120** and the side surface **114a** to be in the landscape display as shown in FIG. 2, the bottom opening **116** for exposing the volume-control bottom **270** would face away from the side surface **114a**, so the user has access to the volume-control bottom **270** for operating the volume-control function during the landscape display.

[0029] In the present embodiment, the casing may further include a first magnetic component **130** and a second magnetic **140**, wherein the first magnetic component **130** is disposed at the supporter **120** and the second magnetic component **140** is disposed at the casing body **110** correspondingly. The first magnetic component **130** and the second magnetic component **140** are attracted to each other. To be more specific, the first magnetic component **130** may be, for example, disposed at the first side **122** as shown in FIG. 1, and the second magnetic component **140** are disposed correspondingly at the casing body **110**. As such, when the supporter **120** is rotated to the covering position, the supporter **120** can be temporarily fixed to the covering position for covering and protecting the portable electronic device **200**. In the present embodiment, the portable electronic device **200** may include an antenna disposed at, for example, a location corresponding to the second side **124**. Therefore, the first magnetic component **130** may keep a distance from the second side **124** in order to avoid interfering with the operation of the antenna. In the present embodiment, a shortest distance **D1** from the first magnetic component **130** to the second side **124** is substantially from 30 mm to 40 mm.

[0030] Certainly, the embodiment described above is merely for illustration, and the invention is not limited thereto. In other embodiment, the supporter **120** further includes a connecting side **128** connected to the bevel side **112c**, and the first magnetic component **130** may be disposed at the connecting side **128** and the second magnetic component **140** is disposed correspondingly at the casing body **110**. In the present embodiment, a shielding layer may be disposed between an antenna of the portable electronic device **200** and the magnetic components **130**, **140**. The invention does not limit the disposition of the first magnetic component **130** and the second magnetic component **140**.

[0031] Referring to FIG. 2, when the supporter **120** is at the supporting position, an included angle θ_1 is formed between an inner surface of the supporter **120** facing the supporter opening **122b** and the back surface **112**, and the included angle θ_1 may range from 68 degrees to 72 degrees which is the best view angle for a user. Also, with the range of the included angle θ_1 , when the supporter **120** is at the supporting position as shown in FIGS. 2 and 3, a normal projection of a center of mass of the portable electronic assembly **10** would fall within a normal projection of the supporter **120** on a horizontal

plane, so the portable electronic assembly **10** is in a stable balance when in landscape display or in portrait display.

[0032] FIG. 4 illustrates a partial cross-sectional view of the casing at a covering position according to an exemplary embodiment. In the present embodiment, when the supporter **120** is at the covering position, the connecting side **128** and the bevel side **112c** define a V-shaped groove as shown in FIG. 4, so the supporter **120** can rotate about the bevel side **112c**. An included angle θ_2 of the V-shaped groove may be designate to substantially range from 32 degrees to 40 degrees such that the included angle θ_1 may substantially range from 70 degrees to 74 degrees as it is described above.

[0033] In addition, the casing **100** may further include an adhesive layer **150** and a micro fiber layer **160** as shown in FIG. 4. The adhesive layer **150** is configured for connecting the supporter **120** and the casing body **110**, wherein the supporter **120** and the casing body **110** are disposed on the adhesive layer **150** and the adhesive layer **150** is disposed on the micro fiber layer **160**. In other words, the supporter **120** and the casing body **110** are connected to each other through the micro fiber layer **160** by the adhesion of the adhesive layer **150**.

[0034] FIG. 5 illustrates a side view of the portable electronic assembly at a supporting position according to an exemplary embodiment. Referring to FIG. 5, in the present embodiment, the portable electronic device **200** may further include a first sensor **250** for detecting whether the supporter **120** is at the covering position or at the supporting position. In the present embodiment, the first sensor comprises a Hall effect sensor. In general, the Hall effect sensor may sense a magnetic force emitted by the first magnetic component **130** disposed on the supporter **120**. As such, when the supporter **120** moves, the magnetic force applied by the first magnetic component **130** on the Hall effect sensor changes, and thus the induced voltage of the carrier of the Hall effect sensor varies accordingly. Accordingly, the portable electronic device **200** detects the voltage variations of the Hall effect sensor, and determines whether the supporter **120** is at the covering position or at the supporting position according to the voltage variations, thereby achieving the positioning and position detection functions.

[0035] In addition, the portable electronic device **200** may further include a second sensor **260** for detecting an orientation state of the portable electronic device **200**. As such, the portable electronic device **200** determine to perform the landscape display or the portrait display according to the orientation state of the portable electronic device **200** detected by the second sensor **260**. To be more specific, the portable electronic device **200** determines to perform the landscape display if the second sensor **260** detects the portable electronic device **200** is in the landscape position as shown in FIG. 2, and the portable electronic device **200** determines to perform the portrait display if the second sensor **260** detects the portable electronic device **200** is in the portrait position as shown in FIG. 3. In the present embodiment, the second sensor **260** includes a gravity sensor.

[0036] FIG. 6 illustrates a flow chart of a display method of a portable electronic assembly according to an exemplary embodiment. Referring to FIGS. 1, 5 and 6, with the disposition described above, a display method for the portable electronic assembly **10** as shown in FIG. 5 is developed, and the display method includes the following steps. Firstly, whether the supporter **120** is at a covering position or at a supporting position is detected (performing step **S110**). In

detail, when the supporter **120** is at the covering position, the supporter **120** covers and protect the portable electronic device **200**, and when the supporter **120** is at the supporting position, the portable electronic device **200** is supported by the first side **122** or the second side **124** of the supporter **120**. Next, an orientation state of the portable electronic device **200** is detected if the supporter **120** is at the supporting position (performing step S120). In other words, if the supporter **120** is detected to be at the supporting position, an orientation state of the portable electronic device **200** is detected to see whether the portable electronic device **200** is in a landscape position or in a portrait position. Then, a landscape display or a portrait display is performed according to the orientation state of the portable electronic device **200** (performing step S130).

[0037] To be more specific, the orientation state of the portable electronic device **200** includes a landscape orientation state and a portrait orientation state. The portable electronic device **200** determines to perform the landscape display if the portable electronic device **200** is detected to be in the landscape orientation state as shown in FIG. 2, and the portable electronic device **200** determines to perform the portrait display if the portable electronic device **200** is detected to be in the portrait orientation state as shown in FIG. 3. In addition, an interactive function may be triggered if the portable electronic device **200** is detected to be in the landscape orientation state. For example, an interactive dialogue may be shown on the display **210** of the portable electronic device **200** for requiring a user's input.

[0038] As it is described above, the portable electronic device **200** may include the first sensor **250** and the second sensor **260**. The first sensor **250** is configured for detecting whether the supporter **120** is at the covering position or at the supporting position. The second sensor **260** is configured for detecting the orientation state of the portable electronic device **200**. In the present embodiment, when the first sensor **250** detects the supporter **120** being at the supporting position, the second sensor **260** is triggered to detect the orientation state of the portable electronic device **200**. Accordingly, the portable electronic device **200** determines to perform the landscape display if the portable electronic device **200** is detected to be in the landscape orientation state, and the portable electronic device **200** determines to perform the portrait display if the portable electronic device **200** is detected to be in the portrait orientation state.

[0039] In sum, the casing of the present invention is configured for partially covering a portable electronic device to form a portable electronic assembly therewith. The casing includes a supporter adapted to rotate relatively to the casing body to be at a covering position and a supporting position. When the supporter is at the covering position, the supporter covers and protects the portable electronic device, and when the supporter is at the supporting position, the portable electronic device is supported by the supporter to perform a landscape display or a portrait display. Therefore, the casing of the present invention is capable of covering and protecting the portable electronic device and also supporting the portable electronic device with a suitable angle for a user to use.

[0040] In addition, a display method for the portable electronic assembly having the casing and the portable electronic device is also developed, wherein the portable electronic device includes the first sensor for detecting whether the supporter is at the covering position or at the supporting position and the second sensor for detecting the orientation

state of the portable electronic device. As such, when the first sensor detects the supporter being at the supporting position, the second sensor is triggered to detect the orientation state of the portable electronic device. Accordingly, the portable electronic device determines to perform a landscape display or a portrait display according to the orientation state of the portable electronic device. Therefore, the portable electronic assembly can automatically perform a landscape display or a portrait display according to the position of the supporter and the orientation state of the portable electronic device, which further increases the convenience in use.

[0041] It will be apparent to those skilled in the art that various modifications and variations can be made to the structure of the present invention without departing from the scope or spirit of the invention. In view of the foregoing, it is intended that the present invention cover modifications and variations of this invention provided they fall within the scope of the following claims and their equivalents.

What is claimed is:

1. A casing, applicable to a portable electronic device, the casing comprising:

a casing body comprising a back surface and a plurality of side surfaces connecting to the back surface, the back surface having a camera opening for exposing a camera shutter of the portable electronic device and a supporter opening having a bevel side not parallel to any of the side surfaces; and

a supporter connected to the bevel side and comprising a first side and a second side, wherein the first side and the second side define a vertex angle, the supporter is adapted to rotate about the bevel side between a covering position and a supporting position, when the supporter is at the covering position, the supporter covers the supporter opening, and the vertex angle and the camera opening are arranged diagonally, when the supporter is at the supporting position, the casing is supported by the vertex angle and one of the side surfaces away from the camera opening for the portable electronic device to perform a landscape display or a portrait display.

2. The casing as claimed in claim 1, further comprising a first magnetic component disposed at the supporter and a second magnetic component disposed at the casing body correspondingly, wherein the first magnetic component and the second magnetic component are attracted to each other.

3. The casing as claimed in claim 2, wherein the first magnetic component is disposed at the first side.

4. The casing as claimed in claim 3, wherein a shortest distance from the first magnetic component to the second side is from 30 mm to 40 mm.

5. The casing as claimed in claim 2, wherein the supporter further comprises a connecting side connected to the bevel side, the first magnetic component is disposed at the connecting side.

6. The casing as claimed in claim 5, wherein when the supporter is at the covering position, the connecting side and the bevel side define a V-shaped groove.

7. The casing as claimed in claim 1, wherein when the supporter is at the supporting position, an included angle is formed between an inner surface of the supporter facing the supporter opening and the back surface, and the included angle ranges from 68 degrees to 72 degrees.

8. The casing as claimed in claim 1, further comprising a micro fiber layer and an adhesive layer for connecting the supporter and the casing body, wherein the supporter and the

casing body are disposed on the adhesive layer and the adhesive layer is disposed on the micro fiber layer.

9. The casing as claimed in claim 1, wherein when the supporter is at the supporting position, a normal projection of a center of mass of the casing is located within a normal projection of the supporter on a horizontal plane.

10. The casing as claimed in claim 1, wherein the casing body further comprises a bottom opening for exposing a volume-control bottom of the portable electronic device, the bottom opening is disposed at one of the side surfaces adjacent to the camera opening.

11. A portable electronic assembly, comprising:

a portable electronic device comprising a display, a camera shutter, a first surface and a second surface opposite to the first surface, wherein the display is disposed on the first surface and the camera shutter is disposed on the second surface; and

a casing partially covering the portable electronic device and exposing the first surface, the casing comprising:

a casing body comprising a back surface and a plurality of side surfaces connecting to the back surface, the back surface having a camera opening for exposing the camera shutter and a supporter opening having a bevel side not parallel to any of the side surfaces; and

a supporter connected to the bevel side and comprising a first side and a second side, wherein the first side and the second side defines a vertex angle, the supporter is adapted to rotate about the bevel side between a covering position and a supporting position, when the supporter is at the covering position, the supporter covers the supporter opening, and the vertex angle and the camera opening are arranged diagonally, when the supporter is at the supporting position, the portable electronic device is supported by the vertex angle and one of the side surfaces away from the camera opening to perform a landscape display or a portrait display.

12. The portable electronic assembly as claimed in claim 11, wherein the casing further comprises a first magnetic component disposed at the supporter and a second magnetic component disposed at the casing body correspondingly, and the first magnetic component and the second magnetic component are attracted to each other for temporarily fixing the supporter to cover the supporter opening.

13. The portable electronic assembly as claimed in claim 12, wherein the first magnetic component is disposed at the first side.

14. The portable electronic assembly as claimed in claim 13, wherein the portable electronic device further comprises an antenna disposed at a position corresponding to the second side.

15. The portable electronic assembly as claimed in claim 13, wherein a shortest distance from the first magnetic component to the second side is from 30 mm to 40 mm.

16. The portable electronic assembly as claimed in claim 12, wherein the supporter further comprises a connecting side connected to the bevel side, the first magnetic component is disposed at the connecting side.

17. The portable electronic assembly as claimed in claim 16, wherein when the supporter is at the covering position, the connecting side and the bevel side define a V-shaped groove.

18. The portable electronic assembly as claimed in claim 11, wherein when the supporter is at the supporting position, an included angle is formed between an inner surface of the

supporter facing the supporter opening and the back surface, and the included angle ranges from 68 degrees to 72 degrees.

19. The portable electronic assembly as claimed in claim 11, wherein the casing further comprises a micro fiber layer and an adhesive layer for connecting the supporter and the casing body, and the supporter and the casing body are disposed on the adhesive layer and the adhesive layer is disposed on the micro fiber layer.

20. The portable electronic assembly as claimed in claim 11, wherein when the supporter is at the supporting position, a normal projection of a center of mass of the casing is located within a normal projection of the supporter on a horizontal plane.

21. The portable electronic assembly as claimed in claim 11, wherein the casing body further comprises a bottom opening for exposing a volume-control bottom of the portable electronic device, the bottom opening is disposed at one of the side surfaces adjacent to the camera opening.

22. The portable electronic assembly as claimed in claim 11, wherein the portable electronic device further comprises a first sensor for detecting the supporter is at the covering position or at the supporting position.

23. The portable electronic assembly as claimed in claim 22, wherein the first sensor comprises a Hall effect sensor.

24. The portable electronic assembly as claimed in claim 11, wherein the portable electronic device further comprises a second sensor for detecting an orientation state of the portable electronic device, the portable electronic device determine to perform the landscape display or the portrait display according to the orientation state of the portable electronic device detected by the second sensor.

25. The portable electronic assembly as claimed in claim 22, wherein the second sensor comprises a gravity sensor.

26. A display method of a portable electronic assembly, wherein the portable electronic assembly comprises a portable electronic device and a casing partially covering the portable electronic device and comprising a casing body and a supporter, the method comprising:

detecting whether the supporter is at a covering position for covering the portable electronic device or at a supporting position for supporting the portable electronic device via the first side or the second side of the supporter;

detecting an orientation state of the portable electronic device if the supporter is at the supporting position; and performing a landscape display or a portrait display according to the orientation state of the portable electronic device.

27. The display method as claimed in claim 26, wherein the orientation state of the portable electronic device comprises a landscape orientation state and a portrait orientation state, when in the landscape orientation state, the portable electronic device performs the landscape display, and when in the portrait orientation state, the portable electronic device performs the portrait display.

28. The display method as claimed in claim 27, further comprising:

triggering an interactive function if the portable electronic device is in the landscape orientation state.

29. The display method as claimed in claim 26, wherein the portable electronic device further comprises a first sensor for detecting the supporter is at the covering position or at the supporting position and a second sensor for detecting the orientation state of the portable electronic device, the method further comprises:

triggering the second sensor when the first sensor detects the supporter being at the supporting position.

30. The display method as claimed in claim **29**, wherein the first sensor comprises a Hall effect sensor and the second sensor comprises a gravity sensor.

* * * * *