



US 20150102900A1

(19) **United States**

(12) **Patent Application Publication**
Ramchandani et al.

(10) **Pub. No.: US 2015/0102900 A1**

(43) **Pub. Date: Apr. 16, 2015**

(54) **KEY FOB DONGLE**

(52) **U.S. Cl.**

(71) Applicant: **RB Distribution, Inc.**, Colmar, PA (US)

CPC **G08C 17/02** (2013.01); **G08C 2201/20** (2013.01); **G08C 2201/50** (2013.01)

(72) Inventors: **Kris Ramchandani**, Harleysville, PA (US); **Venkataramani Kumar**, Lansdale, PA (US)

(57) **ABSTRACT**

(73) Assignee: **RB Distribution, Inc.**, Colmar, PA (US)

Disclosed herein is an improvement of methods and systems used to configure electronic components and modules to a vehicle. A low cost programmer tool, or key fob dongle, may manage devices coupled to a vehicle communication network. The system is designed for on-board management of multiple vehicle network protocols to support configuration of various electronic modules to a vehicle. A method for using a key fob dongle is disclosed herein. The method includes inserting the key fob dongle into an on-board diagnostic (OBD)-II connector of a vehicle, transmitting a communication detection request to the OBD-II connector, and keeping a predetermined amount of times in response to the communication detection request, wherein the keeping a predetermined amount of times identifies a vehicle communication protocol.

(21) Appl. No.: **14/512,852**

(22) Filed: **Oct. 13, 2014**

Related U.S. Application Data

(60) Provisional application No. 61/889,898, filed on Oct. 11, 2013.

Publication Classification

(51) **Int. Cl.**
G08C 17/02 (2006.01)

System Block diagram

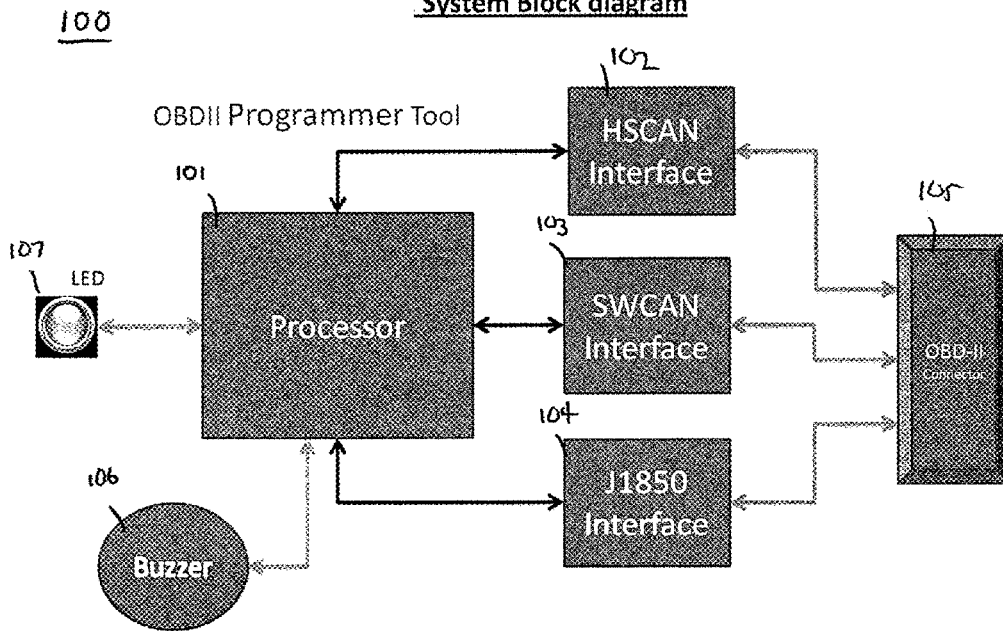

100

Fig 1 System Block diagram

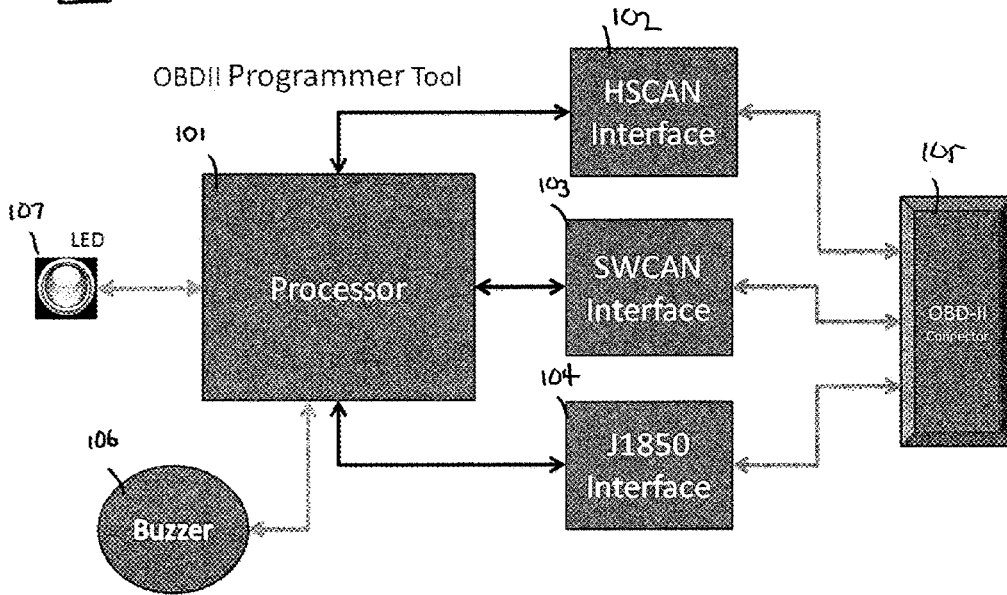

Fig 2 Software Flow Diagram

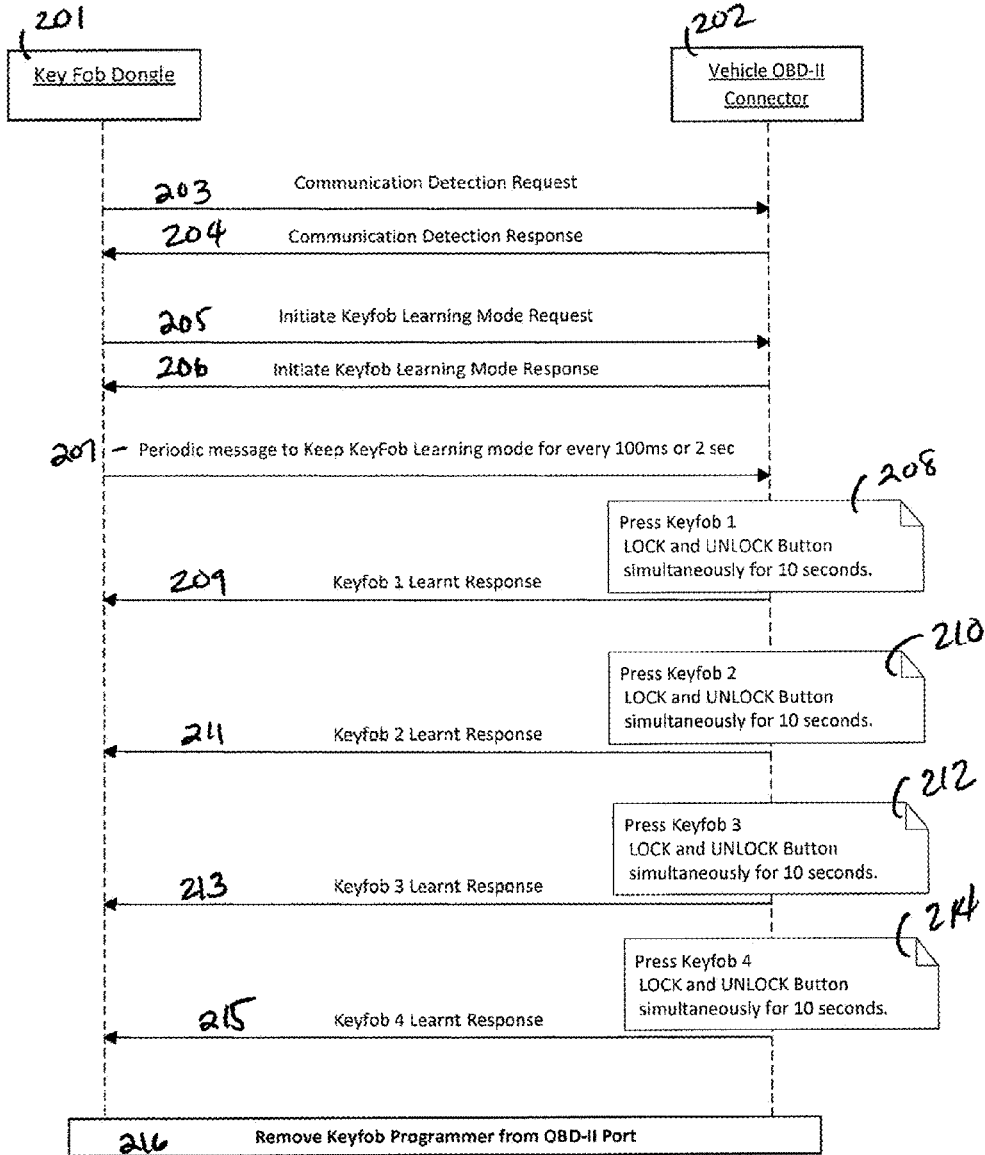

Fig 3 Mechanical Enclosure Views

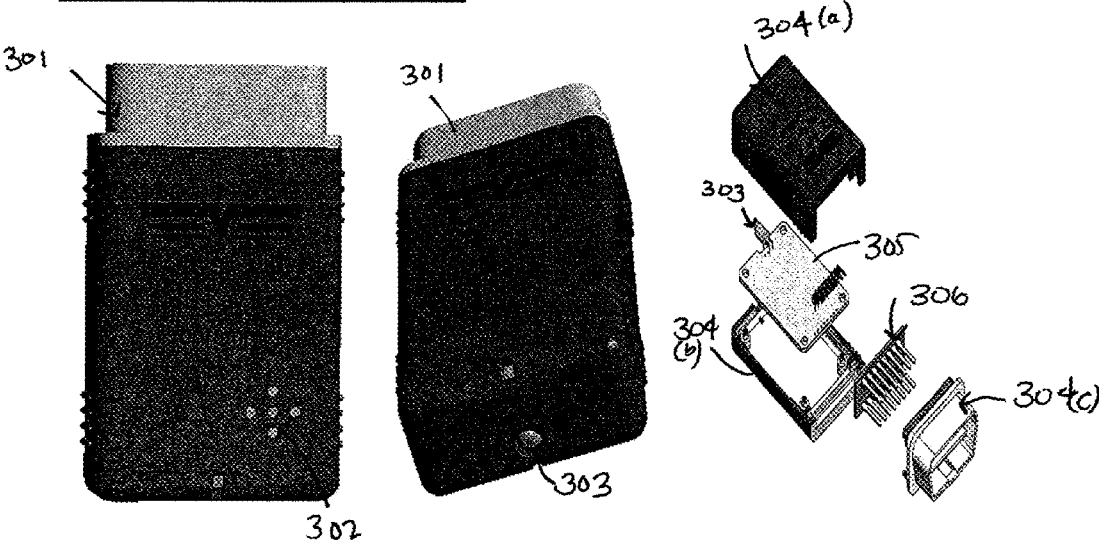

Fig 4 Electronics - PCB (2.5" x 1.5")

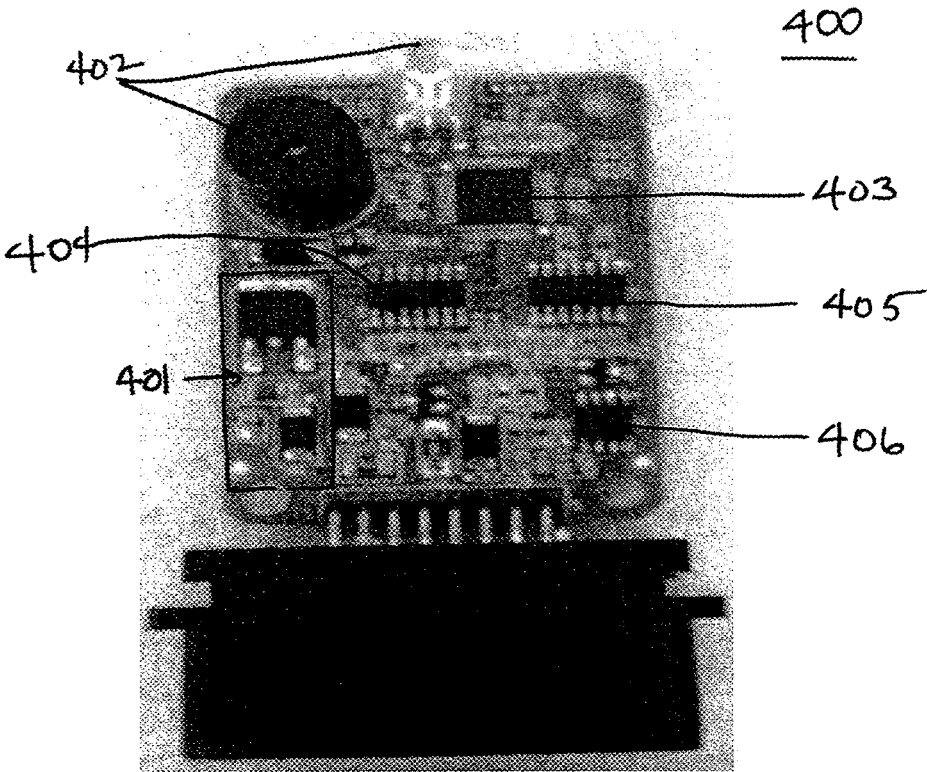

Fig 5 Programmer Software Flowchart:

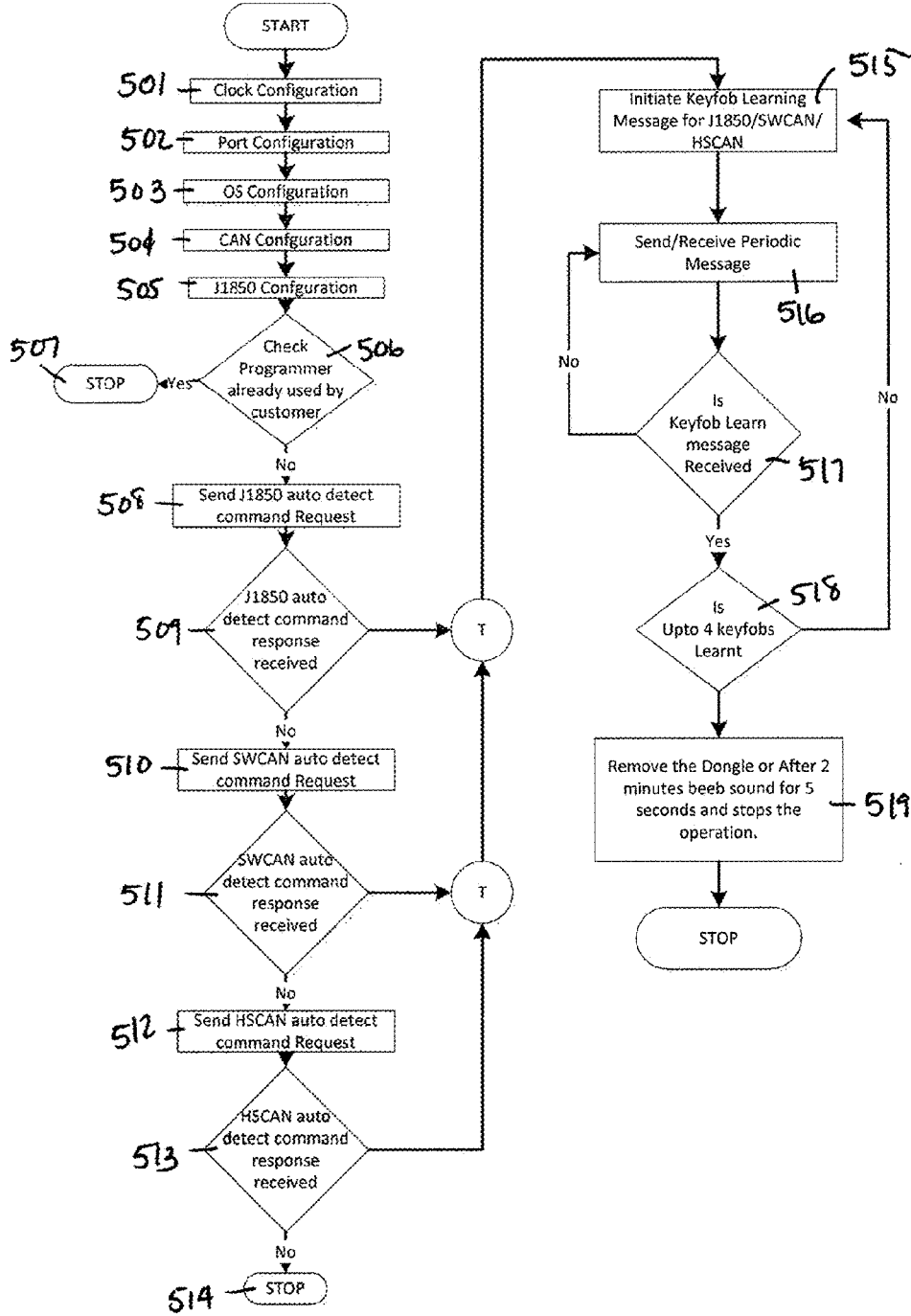

Fig 6 In-Vehicle Network - CAN Bus Example:

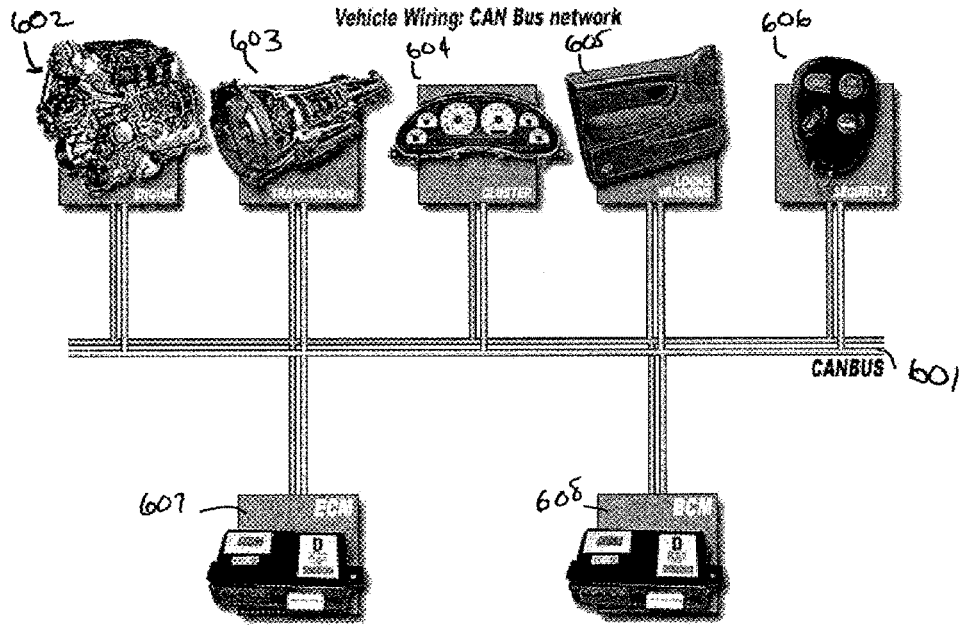
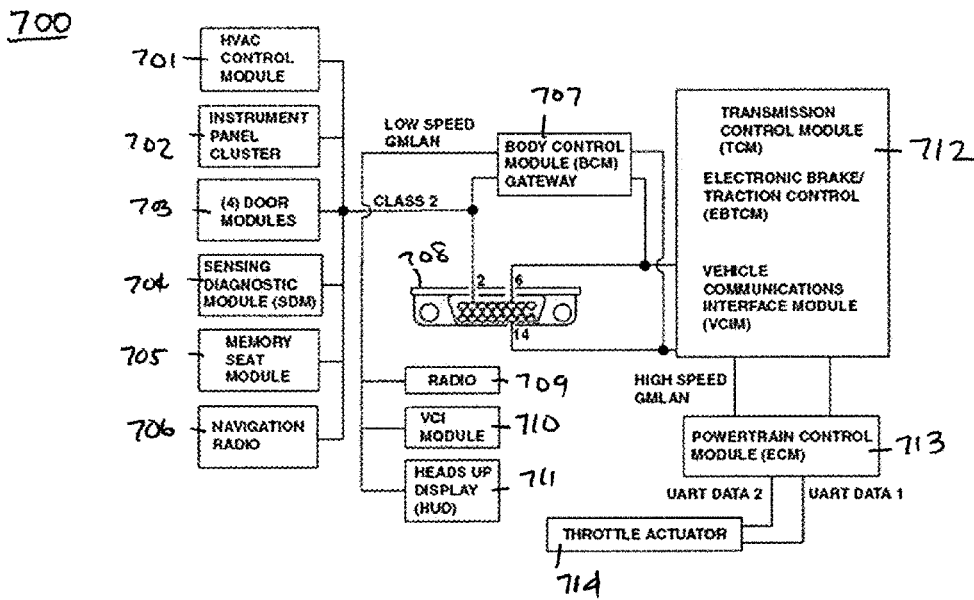

Fig 7 In-Vehicle Network Diagram – OBD-II Example:



KEY FOB DONGLE**CROSS REFERENCE TO RELATED APPLICATION(S)**

[0001] This application claims the benefit of U.S. provisional application No. 61/889,898 filed Oct. 11, 2013, which is incorporated by reference as if fully set forth.

BACKGROUND

[0002] Cars increasingly require a programmable key fob for keyless entry. The programmable key fob contains codes that are specific to a car's onboard computer. If the programmable key fob is lost, the usual source for acquiring a new one is through the dealership. The dealership has the capabilities, including the required programmer, to tap into the car's onboard computer and program a new key fob. Because the dealership programmer includes many extraneous functions besides being able to program the programmable key fob, the dealership performs this function at an extremely high cost to the consumer and the procedure is time consuming. There is a need for a programmable key fob that can be programmed by a consumer using a lower cost programmer tool.

SUMMARY

[0003] Disclosed herein is an improvement in the methods and systems used to configure electronic components and modules for a vehicle. A low cost programmer tool, or key fob dongle, may be useful for managing devices coupled to a vehicle's communication network.

[0004] A dongle and method for using it are disclosed. The dongle is configured to support a method where the dongle is inserted into a vehicle's on-board diagnostic (OBD)-II connector, transmits a communication detection request to the OBD-II connector, and beeps a predetermined amount of times in response to the communication detection request, whereby the predetermined amount of beeping identifies a vehicle communication protocol.

[0005] Disclosed herein is vehicle specific dongle and an improved method or system for configuring electronic components and modules to the vehicle. A low cost programmer tool, key fob dongle, or dongle may be configured to manage multiple devices coupled to the vehicle communication network.

[0006] The scan tool method of synchronizing Keyless Entry Transmitters to a vehicle's receiver used by the dealer, is replaced with a vehicle specific, limited use OBD-II programmer, or dongle. The key fob dongle, when connected directly to a vehicle OBD-II connector (Data Link Connector), in a vehicle network port, initiates a process of registering a maximum number (for example, four) of remote wireless keyless entry transmitters.

[0007] The key fob dongle is a low cost alternative and solution to procedures that previously required the use of a scan tool. It enables key fobs to be paired to a keyless entry receiver of a vehicle by a consumer rather than through an Original Equipment Manufacturer (OEM) Tester.

BRIEF DESCRIPTION OF THE DRAWINGS

[0008] A more detailed understanding may be had from the following description, given by way of example in conjunction with the accompanying drawings wherein:

[0009] FIG. 1 is an example system block diagram of the key fob dongle;

[0010] FIG. 2 is an example software flow diagram;

[0011] FIG. 3 is an example view of the key fob dongle enclosure;

[0012] FIG. 4 is an example of the electronics inside the key fob dongle;

[0013] FIG. 5 is an example of a programmer software flowchart;

[0014] FIG. 6 is an example of an in-vehicle network CAN BUS; and

[0015] FIG. 7. Is an example of an in-vehicle network OBD-II diagram.

DETAILED DESCRIPTION

[0016] This invention is described in the following description with reference to the Figures, in which like reference numbers represent the same or similar elements.

[0017] An example of a method of operation includes the following steps. First there is provided a dongle with a specific vehicle application than can initiate an automatic detection of vehicle communication interfaces. For a given vehicle application, a maximum number (for example, four) of communication systems may be enabled in the key fob dongle to transmit and receive data in accordance with standard communication protocols developed for onboard diagnostics (OBD)-II systems such as ISO15765-4 CAN (Both High Speed and Single Wire CAN), ISO 9141-2 (K-Line), KW2000 and J1850 (Both VPW and PWM variations). Next, the onboard computer identifies modules coupled to the vehicular communication network, for example, the key fob dongle. Then, the specifically configured key fob dongle can enter the particular use mode to initiate or enable installation of required data to the replacement part, for example a programmable key fob.

[0018] In-vehicle networking is a method for transferring data between electronic modules via a serial data BUS. The Society Automotive Engineers (SAE) standards include the following three categories of in-vehicle network communications: Class A, Class B, and Class C. Class A may be low speed (less than 10 Kb/s) and used for convenience features, such as entertainment. Class B may be medium speed (between 10 and 125 Kb/s) and used for general information transfer, such as emission data and instrumentation. Class C may be high speed (greater than 125 Kb/s) and may be used for real-time control, such as traction control, brake by wire, and the like.

[0019] All cars and light trucks built for sale in the United States after 1996 are required to be OBD-II compliant. There are five OBD-II protocol types in use: J1850 PWM, J1850 VPW, ISO 9141-2, ISO 14230 KWP2000, and ISO 15765 CAN. Each protocol differs electrically and by communication format. The key fob dongle must be compatible with the vehicle specific protocol in order to communicate with the OBD-II of the vehicle.

[0020] FIG. 1 is a block diagram depicting the operation of the key fob dongle. The key fob dongle **100** includes a processor **101** that is connected to the three interfaces **102**, **103**, and **104**. The first interface **102** is a High Speed Control Area Network (HSCAN) interface. Controller Area Network (CAN) was designed for automotive applications needing high levels of data and data rates of up to 1 Mbit/s. In 2006 over 70% of all automobiles sold in North America utilized CAN BUS technology. Beginning in 2008, the SAE required 100% of the vehicles sold in the USA to use the CAN BUS communication protocol. CAN messages have a specified

structure dictated by CAN standards. CAN networks have rules for dealing with colliding messages when two modules begin transmitting messages at the same time. HSCAN is classified as a Class C network for both vehicle network and diagnostic communication.

[0021] The second interface **103** is a Single Wire CAN (SWCAN) interface. SWCAN is classified as a Class B network for both vehicle network and diagnostic communication. A CAN physical layer (developed by General Motors) uses only one wire at all times that limits its speed performance to 33.33 kbit/s.

[0022] The third interface **104** is a J1850 interface. This is the SAE standard for Class A and Class B (slow and medium speed) networks. It is a combination of Ford's SCP and General Motors' Class 2 protocol. As J1850 developed from two proprietary protocols, there are two alternative J1850 protocols: 41.6 Kb/s with pulse width modulation and 10.6 Kb/s with variable pulse width. J1850 10.4 VPW is used by General Motors, which internally calls this protocol Class 2. Class 2 is a true network protocol that incorporates BUS arbitration. Class 2 is used for both vehicle network and diagnostic communication.

[0023] Each of the three interfaces **102**, **103**, and **104** connects to a vehicle OBD-II connector **105**. The vehicle OBD-II connector **105** is part of the car's onboard computer. Connecting the dongle **100** to the vehicle OBD-II connector **105** establishes access to the codes necessary to program a replacement part, such as a programmable key fob. Once the dongle **100** is connected to the vehicle OBD-II connector **105**, a signal is transmitted back to the processor **101** through one of the three interfaces **102**, **103**, and **104**. That signal is transmitted to the processor **101** and indicates to the user either by the LED light **107** or by the buzzer **106** that the key fob dongle **100** is ready to start programming the programmable part.

[0024] The dongle automatically detects a vehicle communication protocol once it has been inserted into the OBD-II connector. The classification of communication protocol can be detected through the buzzer sound once it has been inserted into the OBD-II connector. If the buzzer beeps 3 times, the communication protocol for the key fob learning method is J1850. If the buzzer beeps 2 times, the communication protocol is SWCAN. If the buzzer beeps once, the communication protocol is HSCAN. Once the communication has been established, the learning process can begin.

[0025] As soon as the learning process is ready, the user should Press and hold the LOCK and UNLOCK buttons simultaneously on the key fob for 10 seconds. After learning is completed either the instrument cluster in the car or the dongle will give an audible sound, confirming the new part or component has been paired. The same procedure will be applied to the next key fob or component.

[0026] In the preferred device, it programs a maximum number of key fobs in one session. A two minute time-out period is set per session with an audible indication alerting the user to the remove device from the OBD-II connector. The preferred dongle has a counter that limits the number of sessions allowed with the dongle.

[0027] FIG. 2 is an exemplary software flow diagram for using the dongle to program a key fob. In FIG. 2, the dongle **201** sends a communication detection request **203** to the vehicle OBD-II connector **202**. The vehicle OBD-II connector **202** sends a communication detection response **204** to the dongle **201**. The dongle **201** sends an initiate key fob learning mode request **205** to the vehicle OBD-II connector **202**. The

vehicle OBD-II connector **202** sends an initiate learning mode response **206** to the dongle **201**.

[0028] The dongle **201** sends periodic messages **207** to the vehicle OBD-II connector **202** to keep the key fob in learning mode for every 100 ms or 2 seconds. On a first key fob, Key Fob **1**, the LOCK and UNLOCK buttons are pressed simultaneously for 10 seconds **208** communicating with the vehicle OBD-II connector **202**. The vehicle OBD-II connector **202** sends a Key Fob **1** learnt response **209** to the key fob dongle **201**.

[0029] On a second key fob, Key Fob **2**, the LOCK and UNLOCK buttons are pressed simultaneously for 10 seconds **210** communicating with the vehicle OBD-II connector **202**. The vehicle OBD-II connector **202** sends a Key Fob **2** learnt response **211** to the key fob dongle **201**.

[0030] On a third key fob, Key Fob **3**, the LOCK and UNLOCK buttons are pressed simultaneously for 10 seconds **212** communicating with the vehicle OBD-II connector **202**. The vehicle OBD-II connector **202** sends a Key Fob **3** learnt response **213** to the key fob dongle **201**.

[0031] On a fourth key fob, Key Fob **4**, the LOCK and UNLOCK buttons are pressed simultaneously for 10 seconds **214** communicating with the vehicle OBD-II connector **202**. The vehicle OBD-II connector **202** sends a Key Fob **4** learnt response **215** to the key fob dongle **201**. After the last key fob, Key Fob **4**, is learned, the user can remove the key fob dongle **201** from the vehicle OBD-II connector **202**.

[0032] FIG. 3 is an example view of the key fob dongle enclosure. The key fob dongle **301** includes a speaker **302** that allows the user to hear the audible indicator when the dongle is ready for user interaction. The speaker **302** may also be used for providing verbal instructions or indicators. The dongle **301** also includes an LED **303** that allows the user to see the light indicator when the key fob dongle is ready for user interaction. The key fob dongle **301** has a housing **304** that includes a top casing **304(a)**, a bottom casing **304(b)**, and a connector casing **304(c)**. The key fob dongle **301** also includes a circuit board **305** (shown in further detail in FIG. 4) that sits within the housing **304**. A connector **306** sits within housing **304** and is used to connect the key fob dongle to the vehicle OBD-II connector.

[0033] FIG. 4 is an example of the electronics inside the key fob dongle. The functionality of the Printed Circuit Board (PCB) is to provide the necessary hardware/software and OBD-II compliant interfaces to communication with the vehicle OBD-II protocols. One design goal was to select the least expensive components that provide the vehicle interfaces required for a line of vehicle makes and models. Another design goal was to optimize the layout of the components to fit the PCB in a small in a 2.5 inch by 1/8 inch space. Another key fob dongle design criteria was to be compliant with the vehicles specific protocol in order to communicate the necessary message frames.

[0034] The PCB **400** of FIG. 4 includes a power section **401**, an indicator section **402**, a micro controller section **403**, a J1850 section **404**, an SWCAN section **405**, and a HSCAN section **406**.

[0035] The power section **401** regulates to 5Vdc to drive the microcontroller. The Input power is from OBD-II connector Pin **16**—Un-switched Battery+and Power Ground is from OBD-II Pin **4**—Chassis Ground. The 5Vdc regulated power is used for Microcontroller and other peripheral integrated

circuits (ICs). The power regulator provides current and protective functions against over temperature and reverse voltage.

[0036] The indicator section **402** includes the LED and buzzer. The LED and Buzzer provide visual and audio indication for the user to have easier representation of steps necessary in programming the key-fobs. The key indications are information about the Identity of the vehicle protocol and status of a pairing/learning sequence of each key-fob.

[0037] The micro controller section **403** includes a Main Controller Unit (MCU). The MCU used in the design is automotive compliant and minimizes the overall cost of the system while still fulfilling the system specification, for example, performance, reliability, environmental, and the like. The MCU is responsible for the application logic execution with respect to the user requirements and controls the I/O devices connected. The MCE is also responsible for the execution of a sequence of messages based on vehicle identification and user input (Key-fob button press and Vehicle Lock Actuations) to pair with a number of key-fobs. The selected MCU has sufficient I/O pins, necessary peripherals and is powered by a 5Vdc voltage regulator.

[0038] The J1850 section **404** consists of a comparator IC and is connected to the Microcontroller timer capture pin. The comparator compares the received signal and converts to 5V logic to microcontroller. The Microcontroller captures the signal and forms the data to process J1850 protocol logic. The J1850 BUS lines are at OBD-II connector Pin **2**—J1850 High and Pin **10**—J1850 Low.

[0039] The SWCAN section **405** uses an SWCAN transceiver IC to transmit and receive the data between the Microcontroller and Vehicle OBD-II port. The SWCAN works at the rate of 33.33 kbps baud. The SWCAN BUS line is at OBD-II connector Pin **1**—SW CAN.

[0040] The HSCAN section **406** uses an HSCAN transceiver IC to transmit and receive the data between microcontroller and the Vehicle OBD-II port. The HSCAN works at the rate of 500 kbps baud. The HSCAN BUS lines are at OBD-II connector Pin **6**—CAN High and Pin **14**—J1850 CAN Low.

[0041] FIG. 5 is an example of a programmer software flow chart. The software architecture consists of an OS Section, an Interrupt handling Section, a CAN Configuration, a J1850 Configuration, and an Application layer section. The OS Section is the heart-beat of the controller and generates every 1 ms timer count to operate the microcontroller. The Interrupt handling section receives the data and service the application layer without any delay. The CAN Configuration section is used to configure all CAN mail boxes and sets the required baud rate to receive and transmit the CAN data. The J1850 Configuration configures the timer capture input for reception and configures another port as output to transmit the data. It configures the baud rate settings and checks the CRC error check. The Application layer section follows the communication configuration and automatically detects the Vehicle communication protocol once it has been inserted to the OBD-II port. The classification of communication protocol can be detected through the buzzer sound once it has been inserted into the OBD-II port. The Learning Procedure is initiated after the user presses and holds the LOCK and UNLOCK buttons simultaneously in the key fob for 10 seconds. A two minute time-out period is set per session with the buzzer indication to alert the user to remove programmer tool

from OBD-II port. The key fob dongle has a built in counter to limit the number of sessions allowed and is a disposable device.

[0042] In FIG. 5, the process starts by starting the clock configuration **501**, the port configuration **502**, the OS configuration **503**, the CAN configuration **504**, and the J1850 configuration **505**. The key fob dongle is then checked **506** to determine if it was already used by a customer. On a condition that the key fob dongle has already been used, then the process stops **507**. On a condition that the key fob dongle has not already been used, then a J1850 auto detect command request may be sent **508**. It is then determined if a J1850 auto detect command response is received **509**.

[0043] On a condition that the J1850 auto detect command response is not received, a SWCAN auto detect command request is sent **510**. It is then determined if a SWCAN auto detect command response is received **511**. On a condition that the SWCAN auto detect command response is not received, a HSCAN auto detect command request is sent **512**. It is then determined if an auto detect command response is received **513**. On a condition that the HSCAN auto detect command is not received, the process is stopped **514**.

[0044] On a condition that the J1850/SWCAN/HSCAN auto detect command response is received, the key fob learning message is initiated **515** for J1850/SWCAN/HSCAN. Periodic messages are then sent and received by the key fob dongle **516**. It is then determined if the key fob learn message is received **517**. On a condition that the key fob learn message is not received, the process repeats the sending and receiving of periodic messages **516**. On a condition that the key fob learn message is received, the process determines if up to a maximum number of key fobs have been learnt **518**. On a condition that the maximum number of key fobs have not been learnt, the process repeats itself by initiating a key fob learning message for J1850/SWCAN/HSCAN **515**. On a condition that the maximum number of key fobs have been learnt, the key fob dongle is either removed or after two minutes a beep will sound for five seconds and the operation stops **519**.

[0045] FIG. 6 is an example of an in-vehicle network CAN BUS. The CAN BUS **601** is connected to the engine **602**, the transmission **603**, the instrument cluster **604**, the lock window **605** and the security **606**. Additionally, the CAN BUS **601** is connected to the electronic control module (ECM) **607** and the body control module (BCM) **608**.

[0046] FIG. 7 is an example of an in-vehicle network OBD-II diagram. In FIG. 7, a body control module (BCM) gateway **707** is connected to an HVAC control module **701**, an instrument panel cluster **702**, (4) door modules **703**, a sensing diagnostic module **704**, a memory seat module **705**, and a navigation radio **706** at a class 2. The BCM gateway **707** is also connected to a radio **709**, a VCI module **710**, and a head up display (HUD) **711** at low speed GMLAN.

[0047] The BCM gateway **707** is connected to the transmission control module (TCM), electronic brake/traction control (EBTCM), and vehicle communications interface module (VCIM) (collectively **712**) at a high speed GMLAN. The TCM/EBTCM/VCIM **712** is connected to the powertrain control module (ECM) **713**. The ECM **713** is connected to the throttle actuator **714** via UART data 1 and UART data 2. The OBD-II **708** is connected to the BCM gateway **707** and the TCM/EBTCM/VCIM **712**

[0048] Those of ordinary skill in the art may recognize that many modifications and variations of the above may be

implemented without departing from the spirit or scope of the following claims. Thus, it is intended that the following claims cover the modifications and variations provided they come within the scope of the appended claims and their equivalents.

What is claimed:

1. A method for using a key fob dongle, the method comprising:

inserting the key fob dongle into an on-board diagnostic (OBD)-II connector of a vehicle;

transmitting a communication detection request to the OBD-II connector; and

beeping a predetermined amount of times in response to the communication detection request;

wherein the beeping a predetermined amount of times identifies a vehicle communication protocol.

2. The method of claim **1**, wherein the key fob dongle beeps three times to indicate that the vehicle communication protocol is J1850.

3. The method of claim **1**, wherein the key fob dongle beeps two times to indicate that the vehicle communication protocol is single wire control area network (SWCAN).

4. The method of claim **1**, wherein the key fob dongle beeps one time to indicate that the vehicle communication protocol is high speed control area network (SWCAN).

5. The method of claim **1**, wherein the beeping a predetermined amount of times prompts a user to press and hold the lock and unlock buttons simultaneously of a key fob to program the key fob.

6. The method of claim **5**, wherein after the user programs the key fob, the key fob dongle beeps again to confirm the key fob is programmed.

7. The method of claim **5**, wherein after the user programs the key fob, a cluster in the car beeps to confirm the key fob is programmed.

8. A dongle for use in programming a key fob transmitter, the dongle comprising:

a connector to connect the dongle to an on-board diagnostic of a vehicle;

a circuit board, wherein the circuit board includes a program to read to the on-board diagnostic of the vehicle and determine what program to use for programming the key fob;

a buzzer, wherein the buzzer indicates the program of the on-board diagnostic of the vehicle and a start to user interaction, and

a light emitting diode (LED), wherein the LED is used to indicate that the programming is complete.

9. The dongle of claim **8**, wherein the key fob dongle beeps three times to indicate that the vehicle communication protocol is J1850.

10. The dongle of claim **8**, wherein the key fob dongle beeps two times to indicate that the vehicle communication protocol is single wire control area network (SWCAN).

11. The dongle of claim **8**, wherein the key fob dongle beeps one time to indicate that the vehicle communication protocol is high speed control area network (SWCAN).

12. The dongle of claim **8**, wherein the beeping a predetermined amount of times prompts a user to press and hold the lock and unlock buttons simultaneously of a key fob to program the key fob.

13. The dongle of claim **12**, wherein after the user programs the key fob, the key fob dongle beeps again to confirm the key fob is programmed.

14. The dongle of claim **12**, wherein after the user programs the key fob, a cluster in the car beeps to confirm the key fob is programmed.

* * * * *