



(19) **United States**

(12) **Patent Application Publication**

Yang et al.

(10) **Pub. No.: US 2020/0092068 A1**

(43) **Pub. Date: Mar. 19, 2020**

(54) **ACKNOWLEDGEMENT CODEBOOK
DESIGN FOR MULTIPLE TRANSMISSION
RECEPTION POINTS**

H04W 72/04 (2006.01)

H04W 52/10 (2006.01)

(52) **U.S. Cl.**

CPC *H04L 5/0055* (2013.01); *H04L 1/1819*
(2013.01); *H04W 52/10* (2013.01); *H04W*
72/0446 (2013.01); *H04W 72/042* (2013.01);
H04L 1/1896 (2013.01)

(71) Applicant: **QUALCOMM Incorporated**, San Diego, CA (US)

(72) Inventors: **Wei Yang**, San Diego, CA (US); **Yi Huang**, San Diego, CA (US); **Peter Gaal**, San Diego, CA (US); **Xiaoxia Zhang**, San Diego, CA (US)

(57)

ABSTRACT

Methods, systems, and devices for wireless communications are described. A user equipment (UE) may receive a slot allocation to provide hybrid automatic repeat request (HARQ) acknowledgement (ACK) feedback to multiple transmission reception points (TRPs). For example, each TRP may be allocated at least one slot for HARQ-ACK feedback such that HARQ-ACK feedback for different TRPs may not be transmitted in a same slot. Additionally, the UE may determine a TRP-specific HARQ-ACK codebook for feedback transmissions to each TRP in their corresponding slots. In some cases, the UE may also determine TRP-specific uplink parameters for the feedback transmissions to each TRP. The UE may then transmit feedback to a TRP using a corresponding slot from the slot allocation and using the TRP-specific HARQ-ACK codebook and the TRP-specific uplink parameters.

(21) Appl. No.: **16/573,832**

(22) Filed: **Sep. 17, 2019**

Related U.S. Application Data

(60) Provisional application No. 62/733,519, filed on Sep. 19, 2018.

Publication Classification

(51) **Int. Cl.**

H04L 5/00 (2006.01)

H04L 1/18 (2006.01)

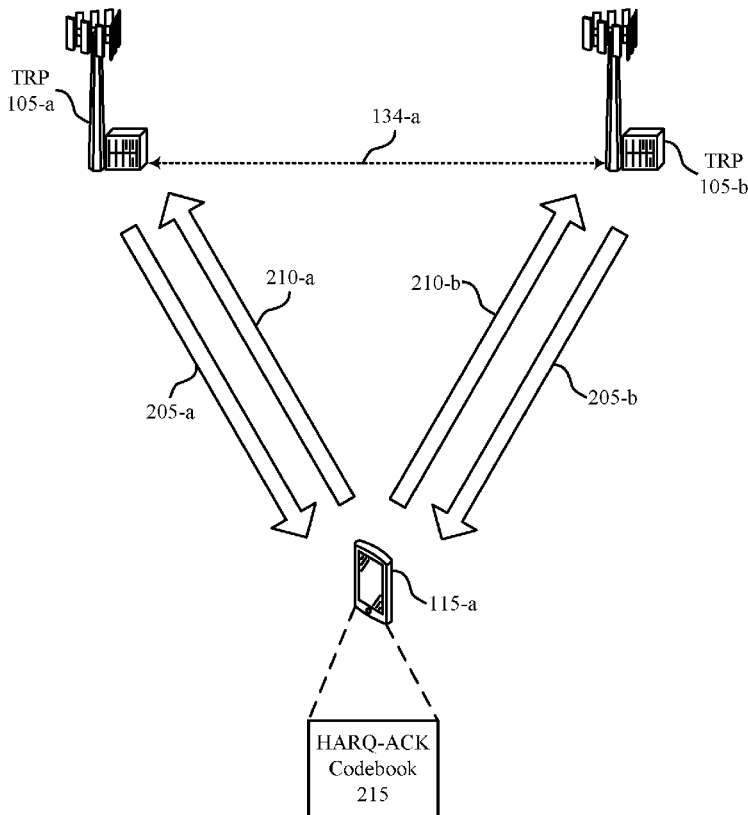

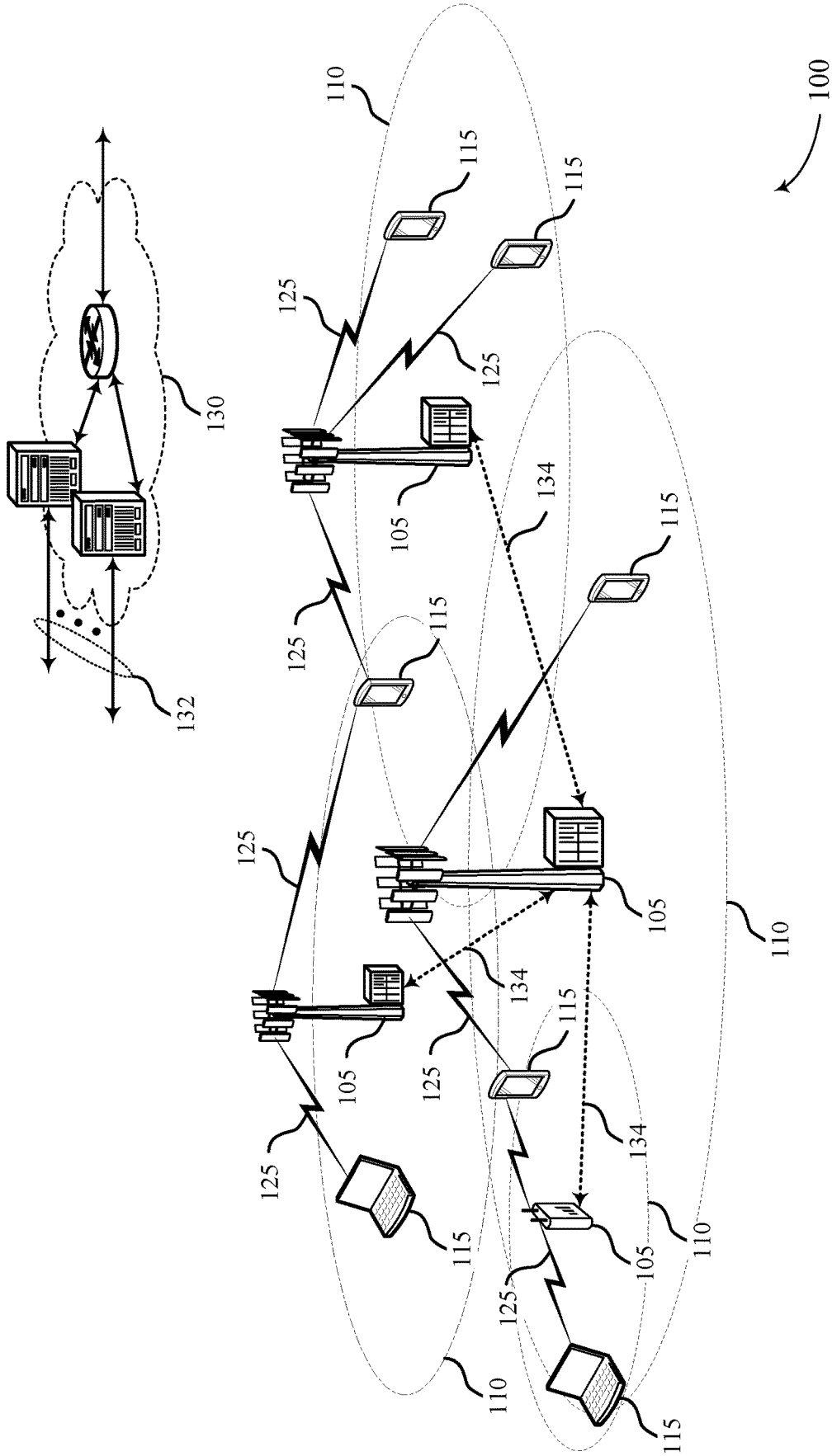

FIG. 1

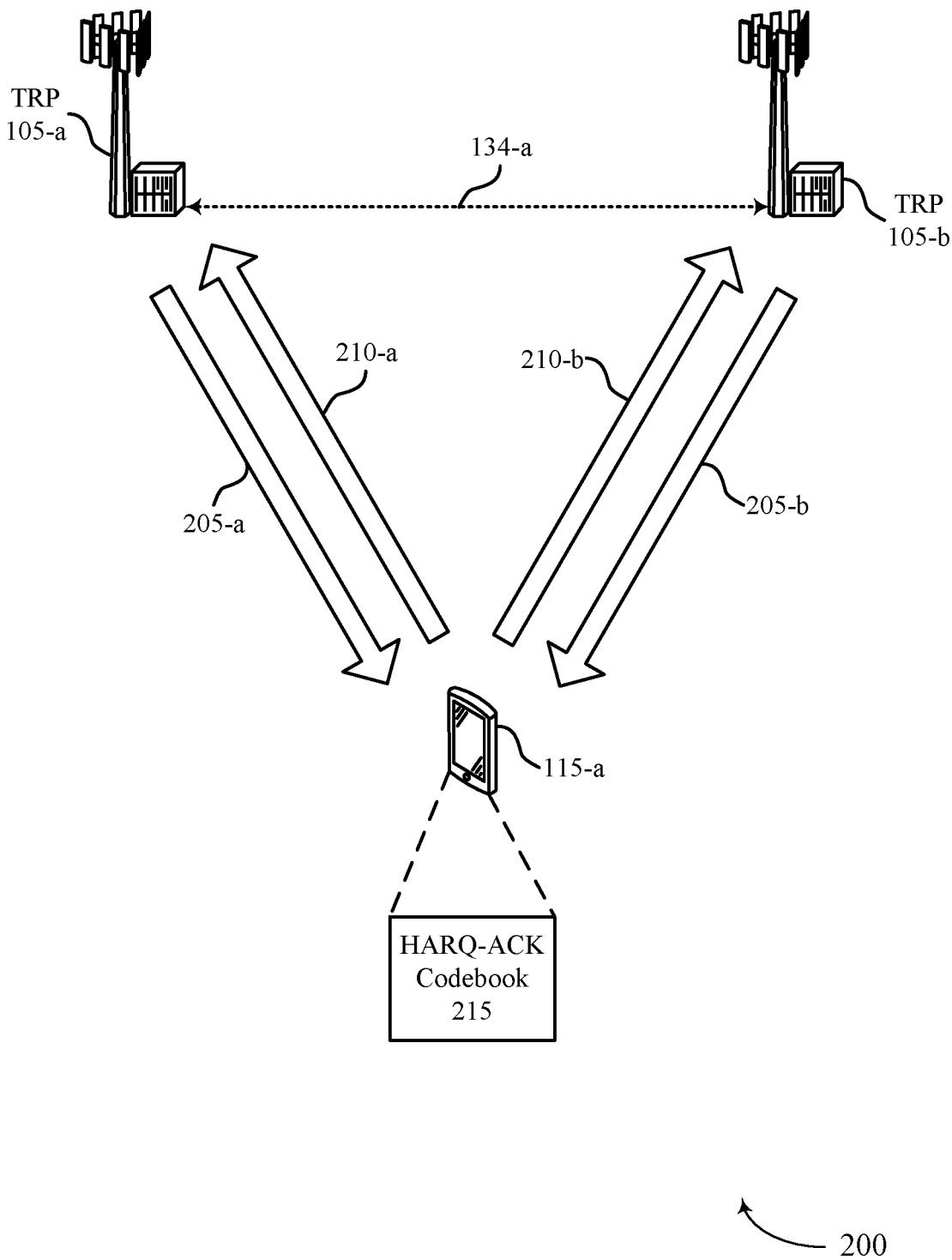

FIG. 2

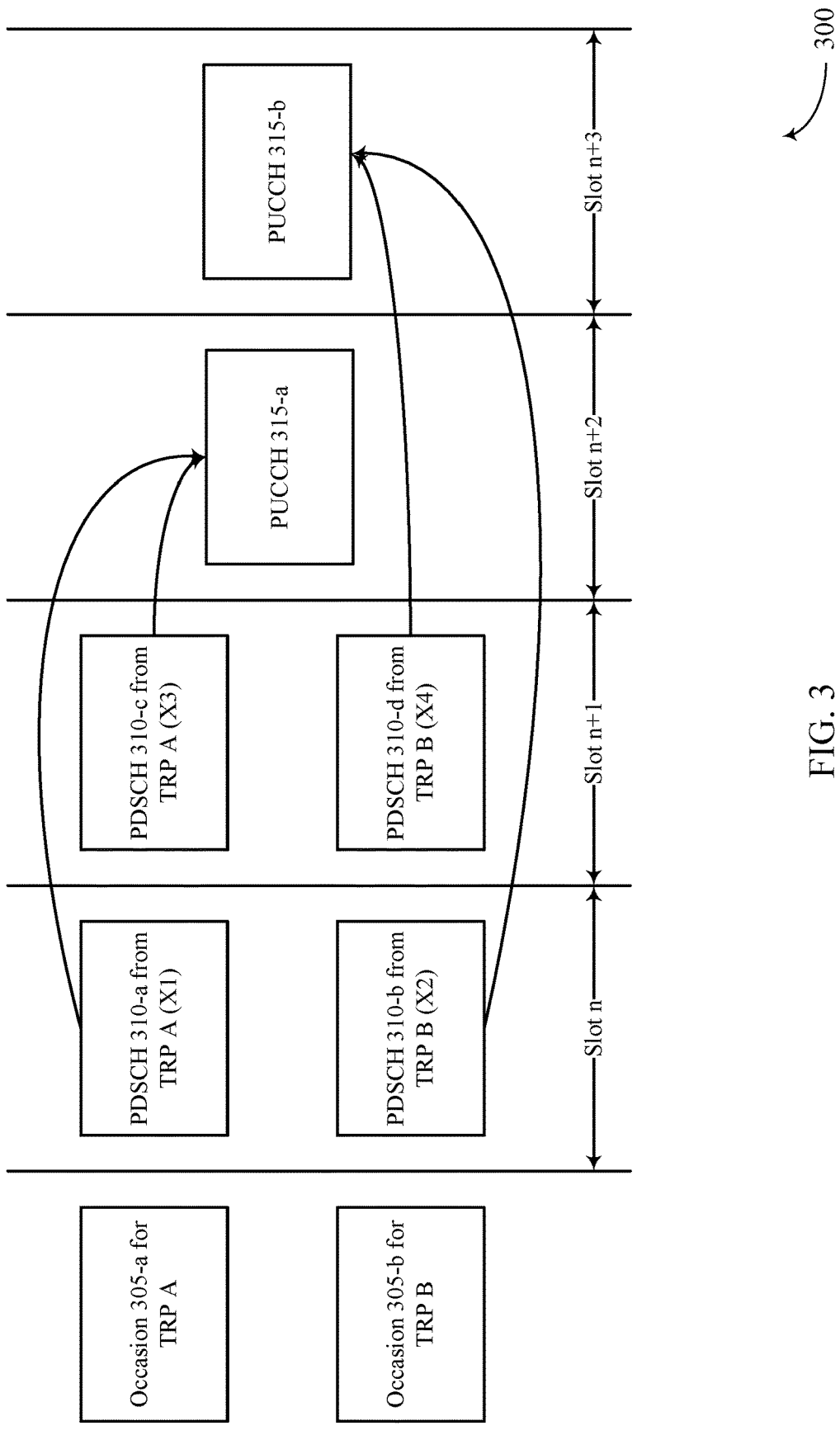
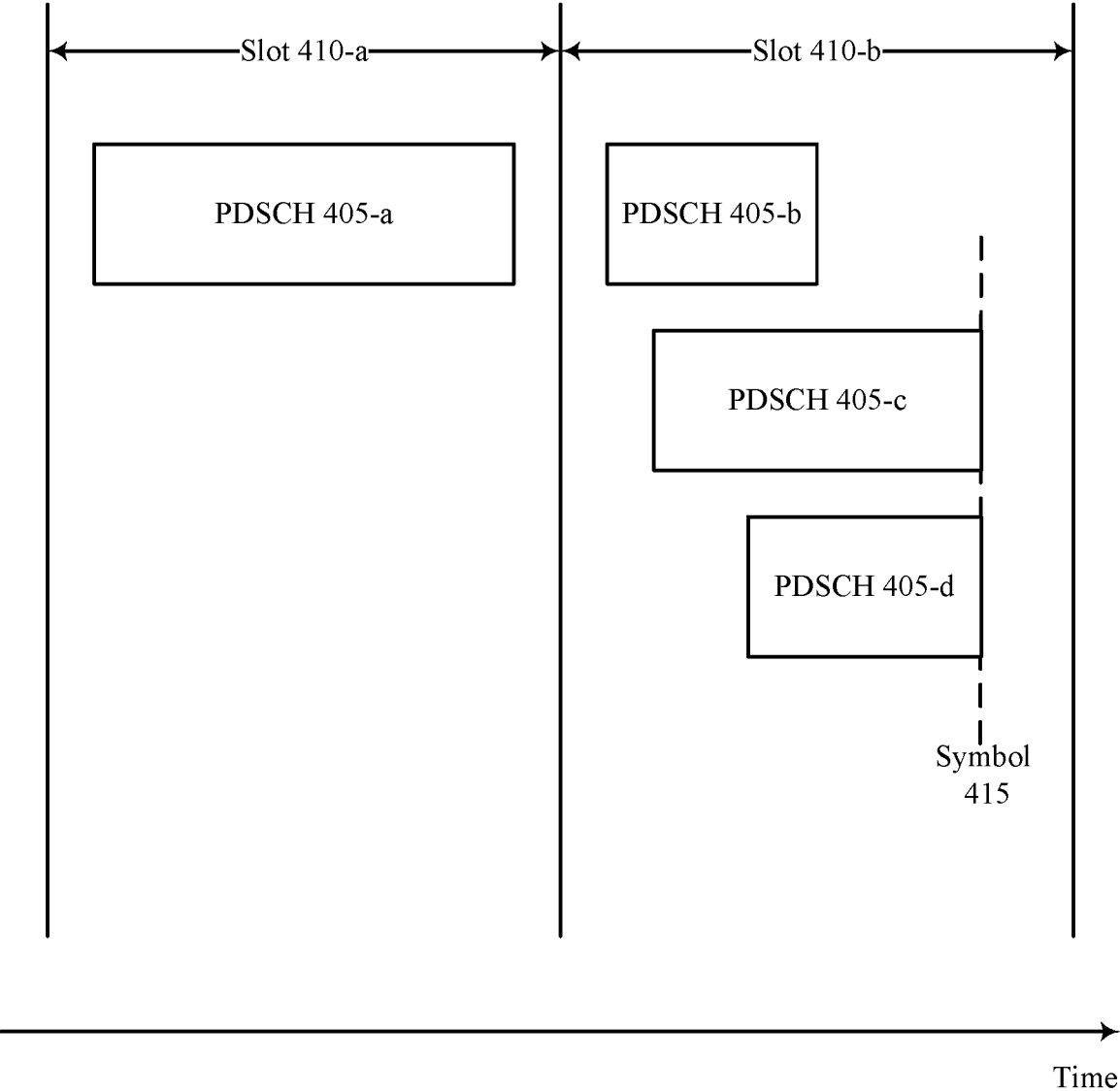
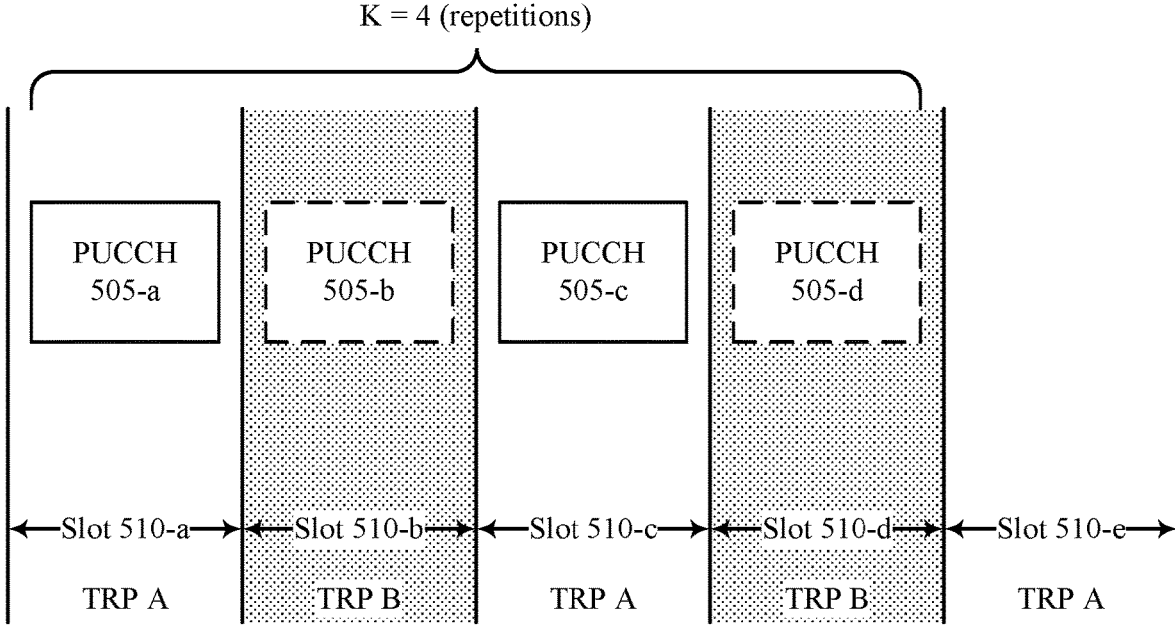

FIG. 3



400

FIG. 4



500

FIG. 5

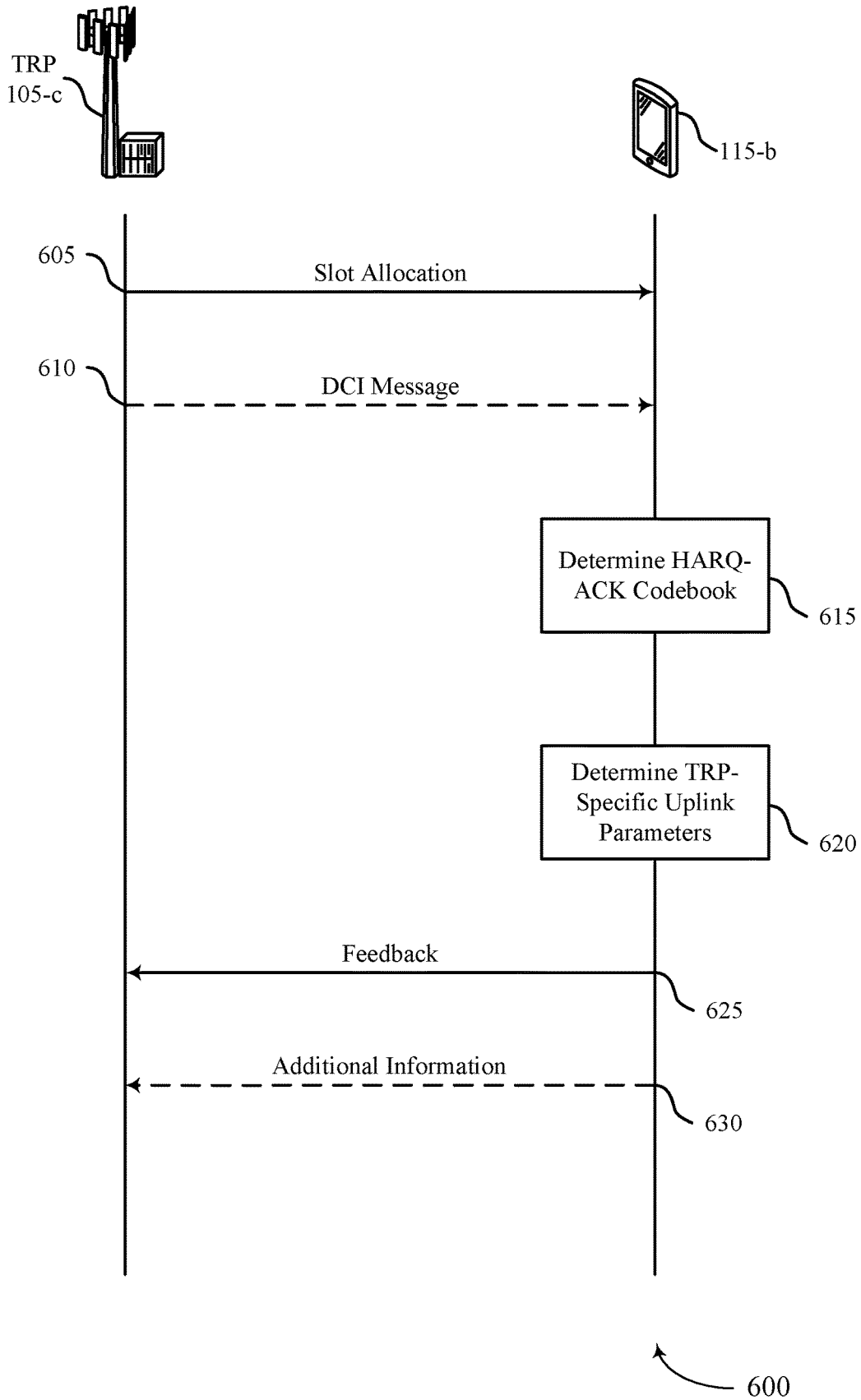

FIG. 6

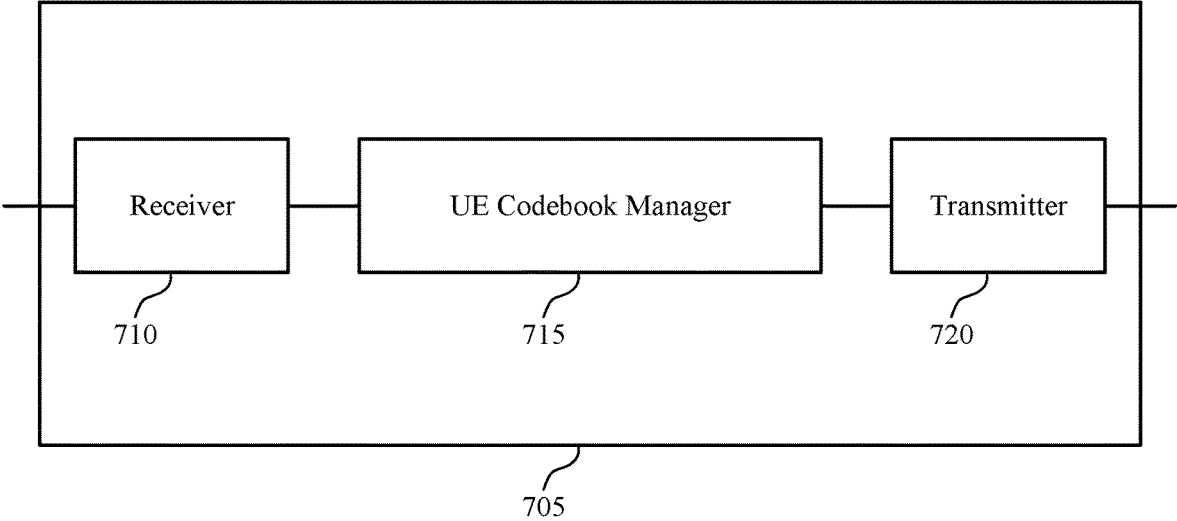

FIG. 7

700

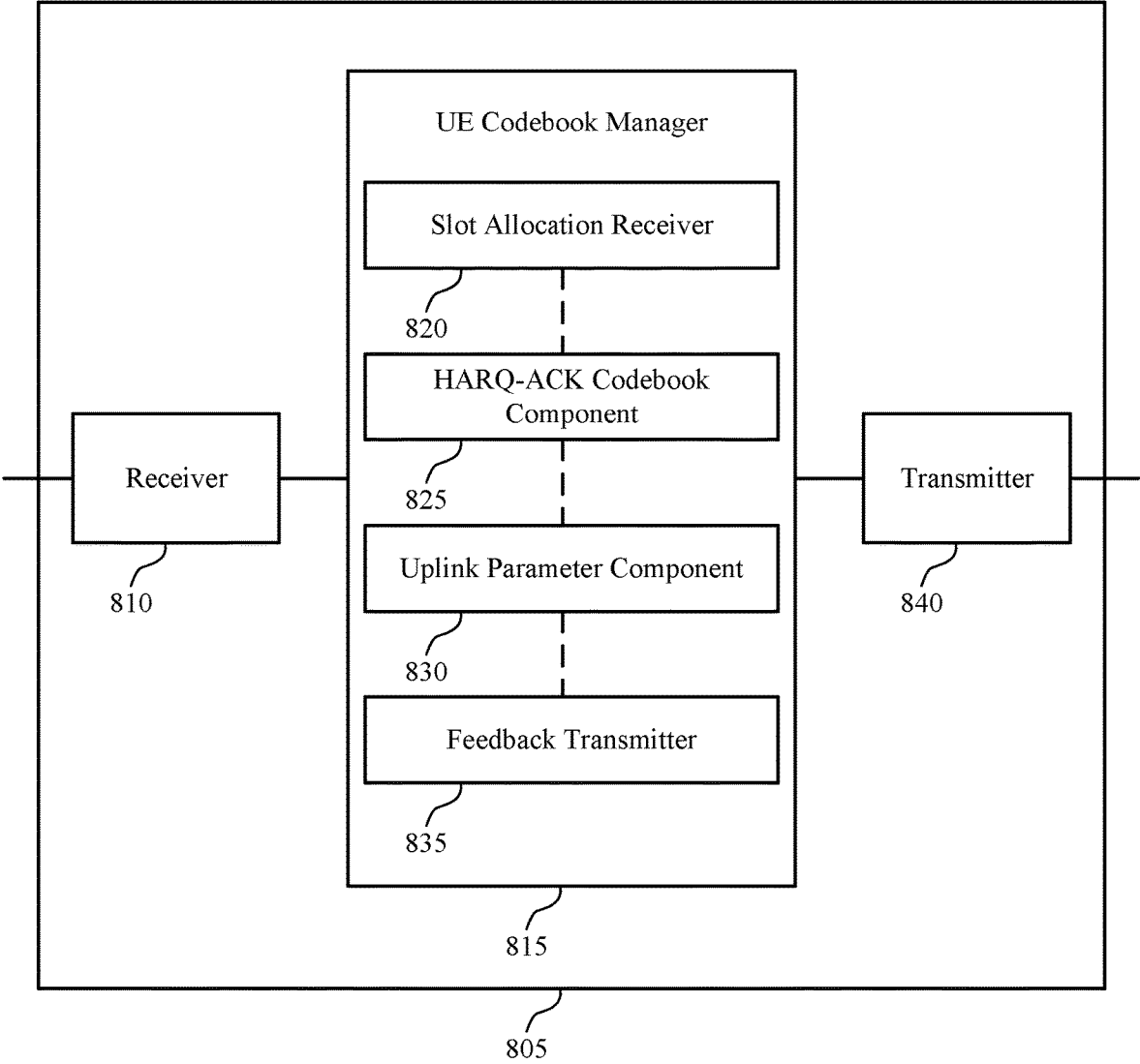

FIG. 8

800

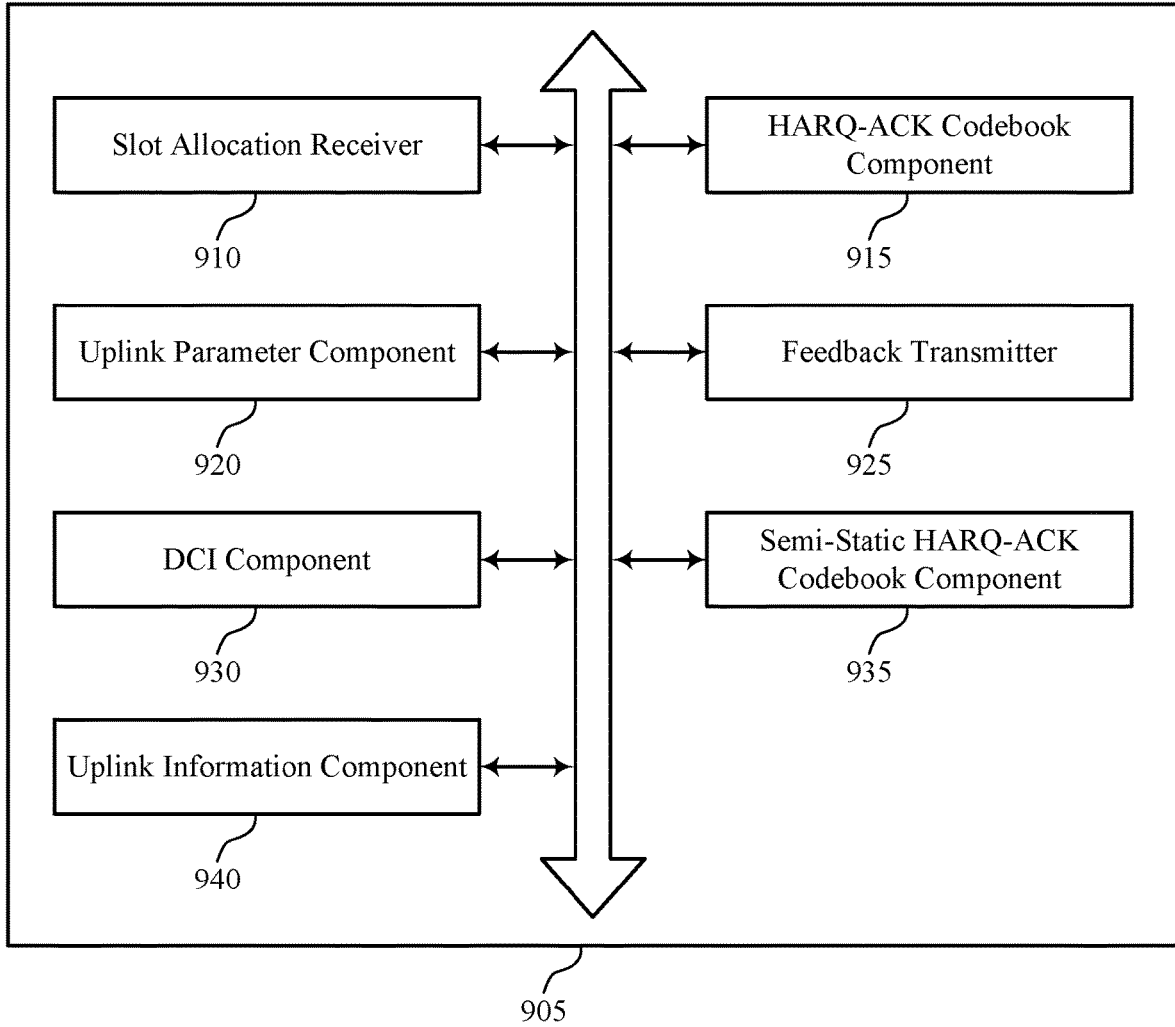

FIG. 9

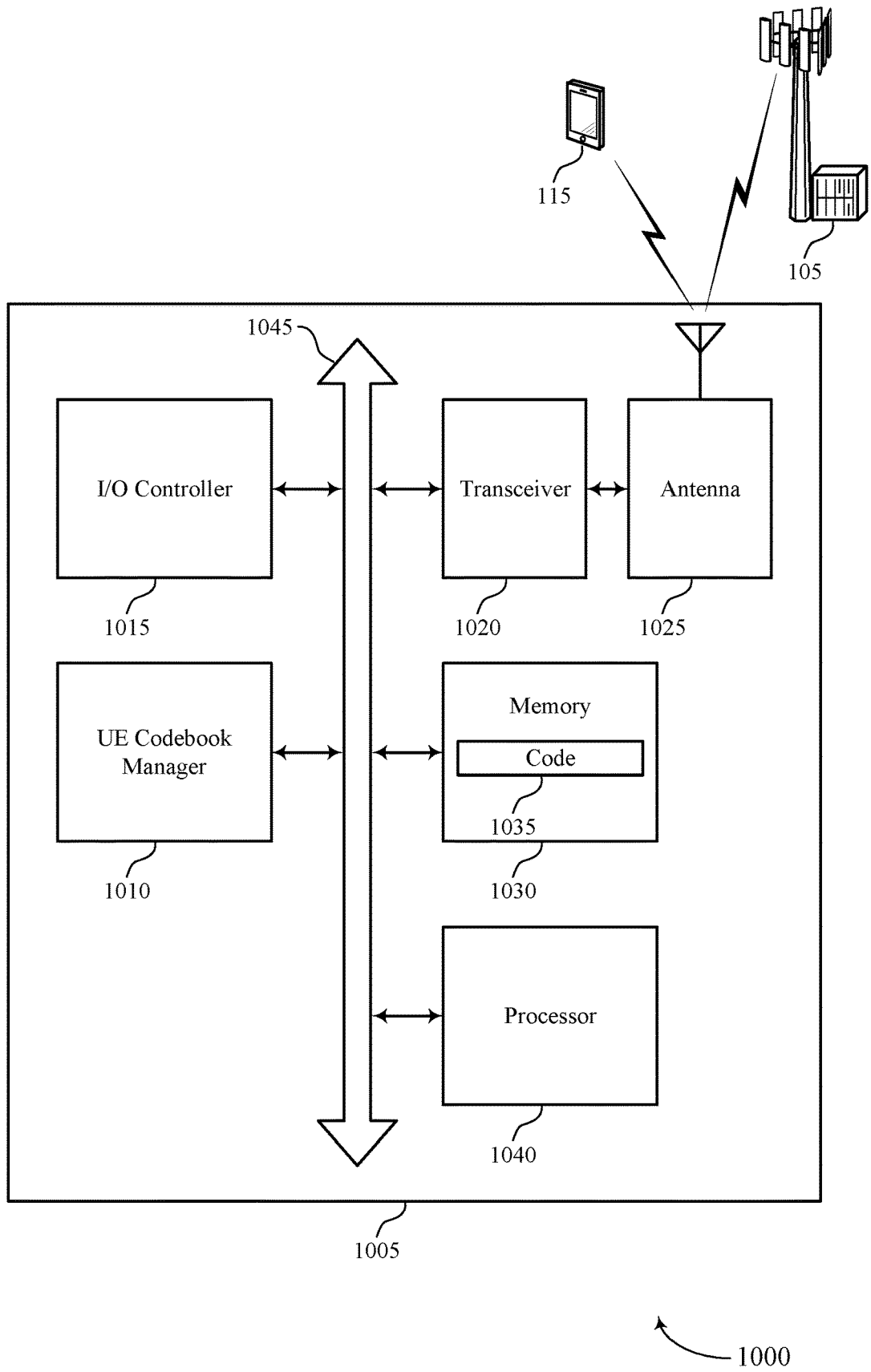

FIG. 10

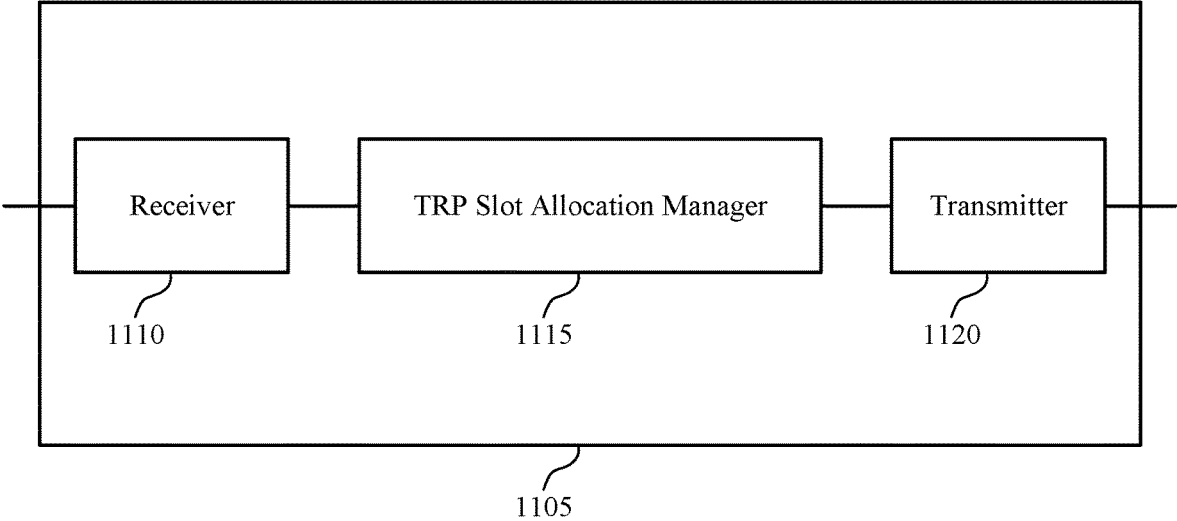

FIG. 11

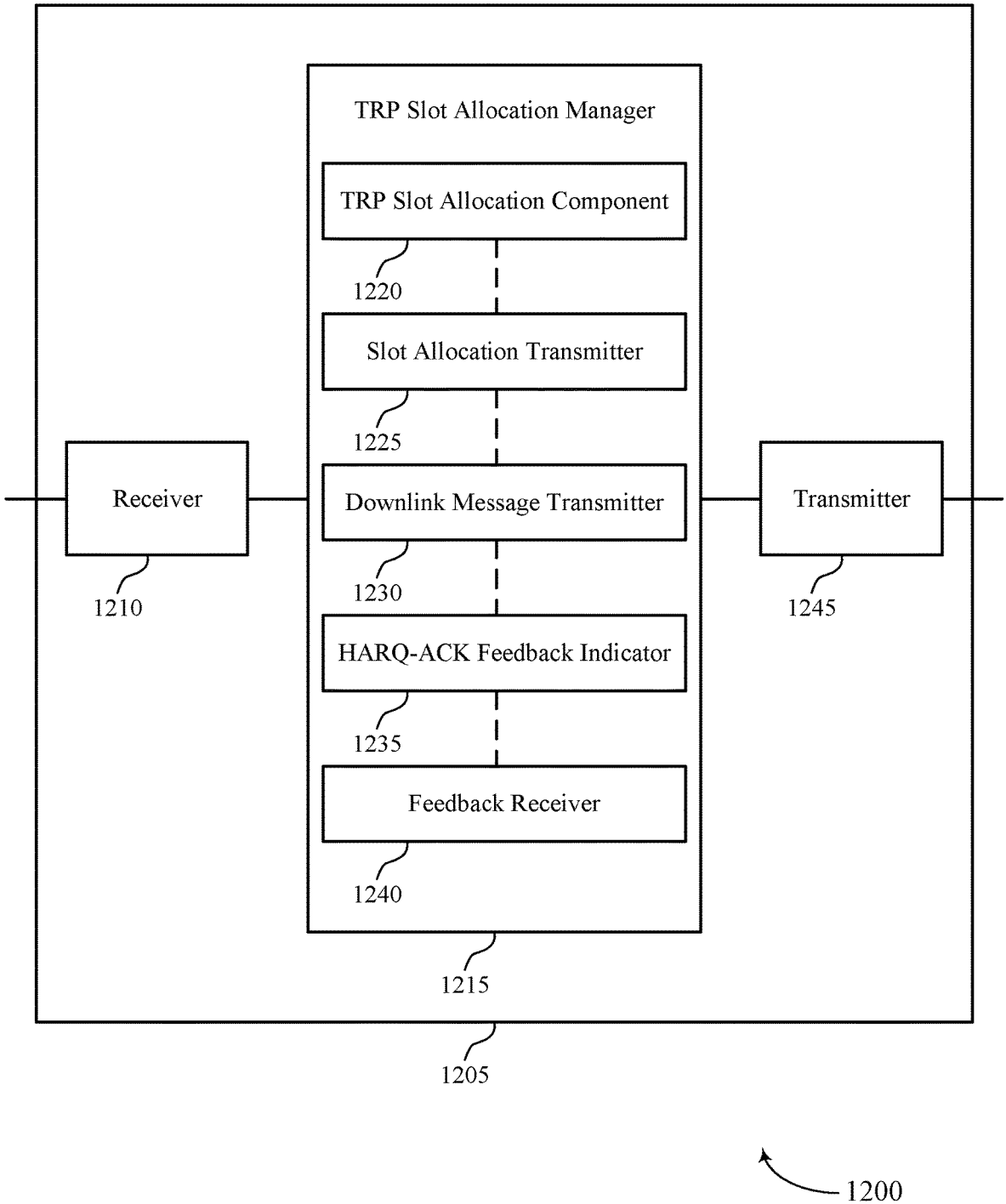

FIG. 12

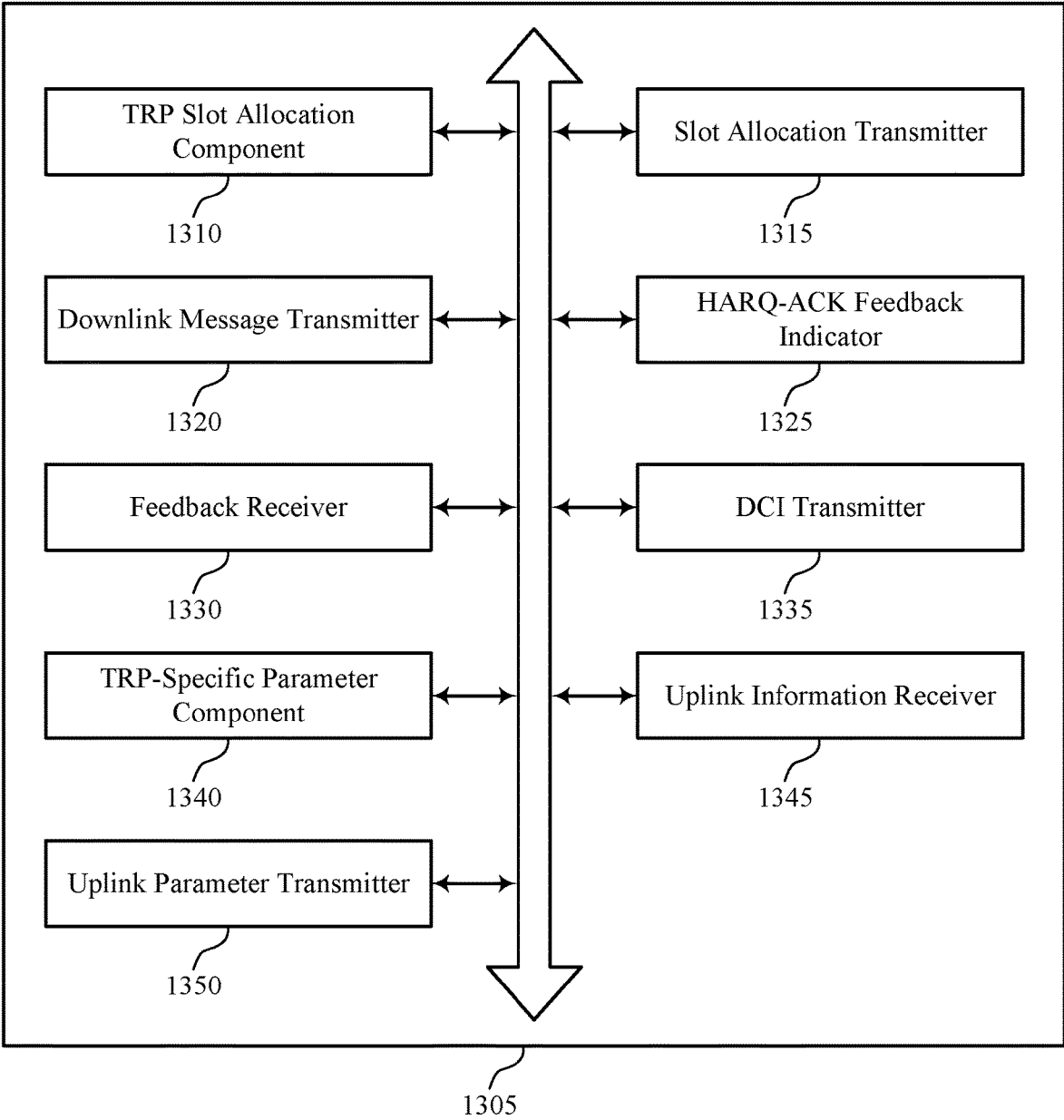

FIG. 13

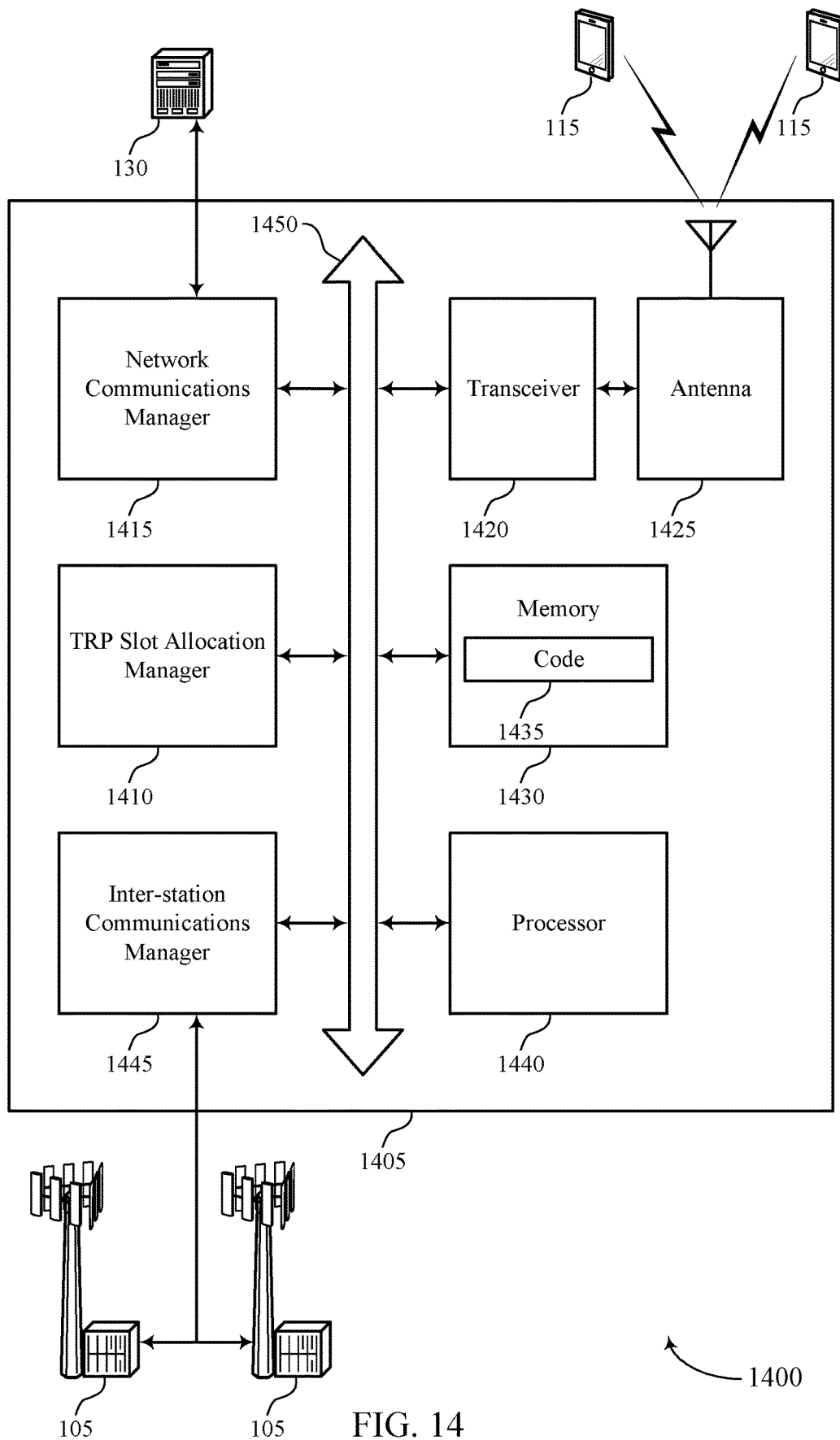

FIG. 14

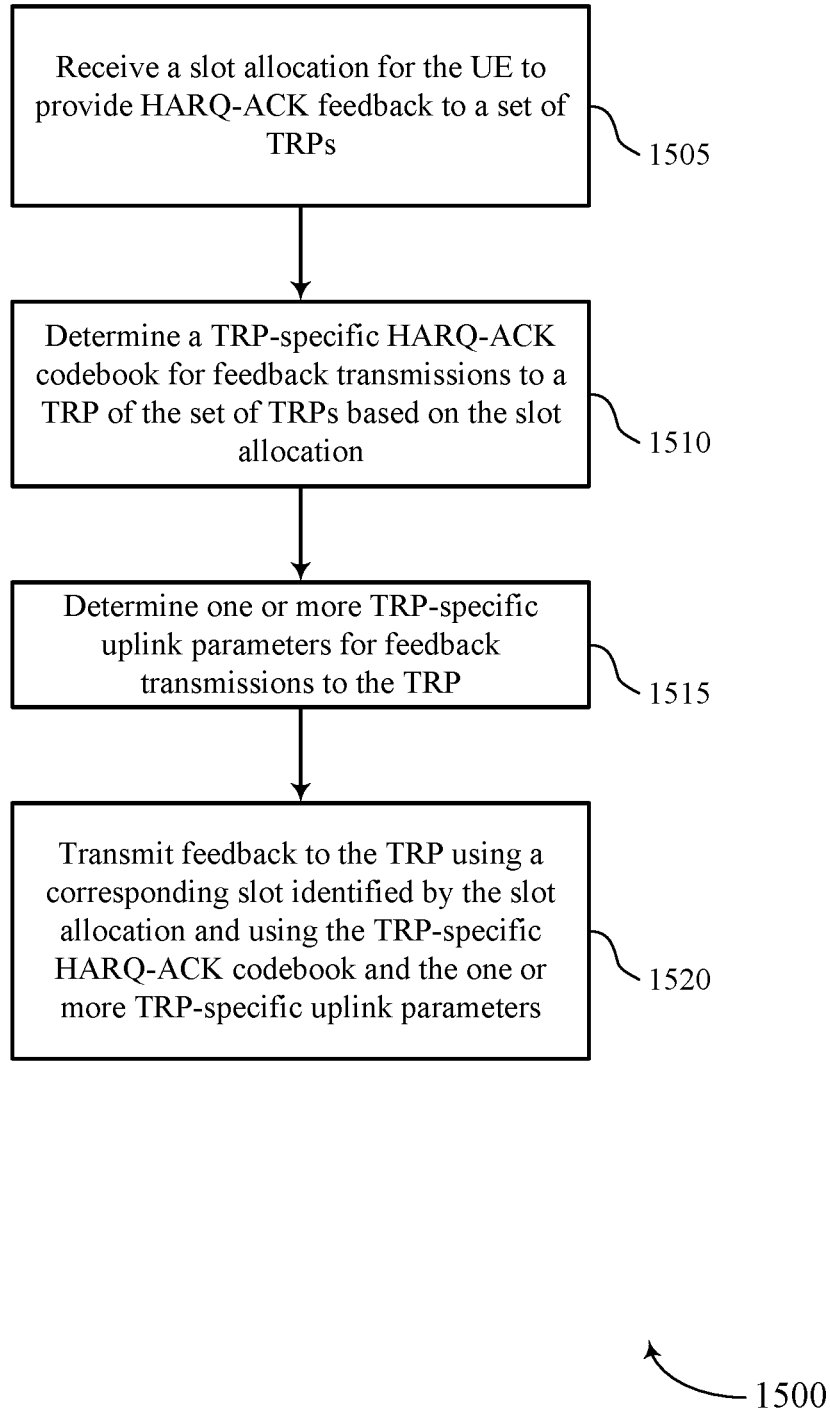

FIG. 15

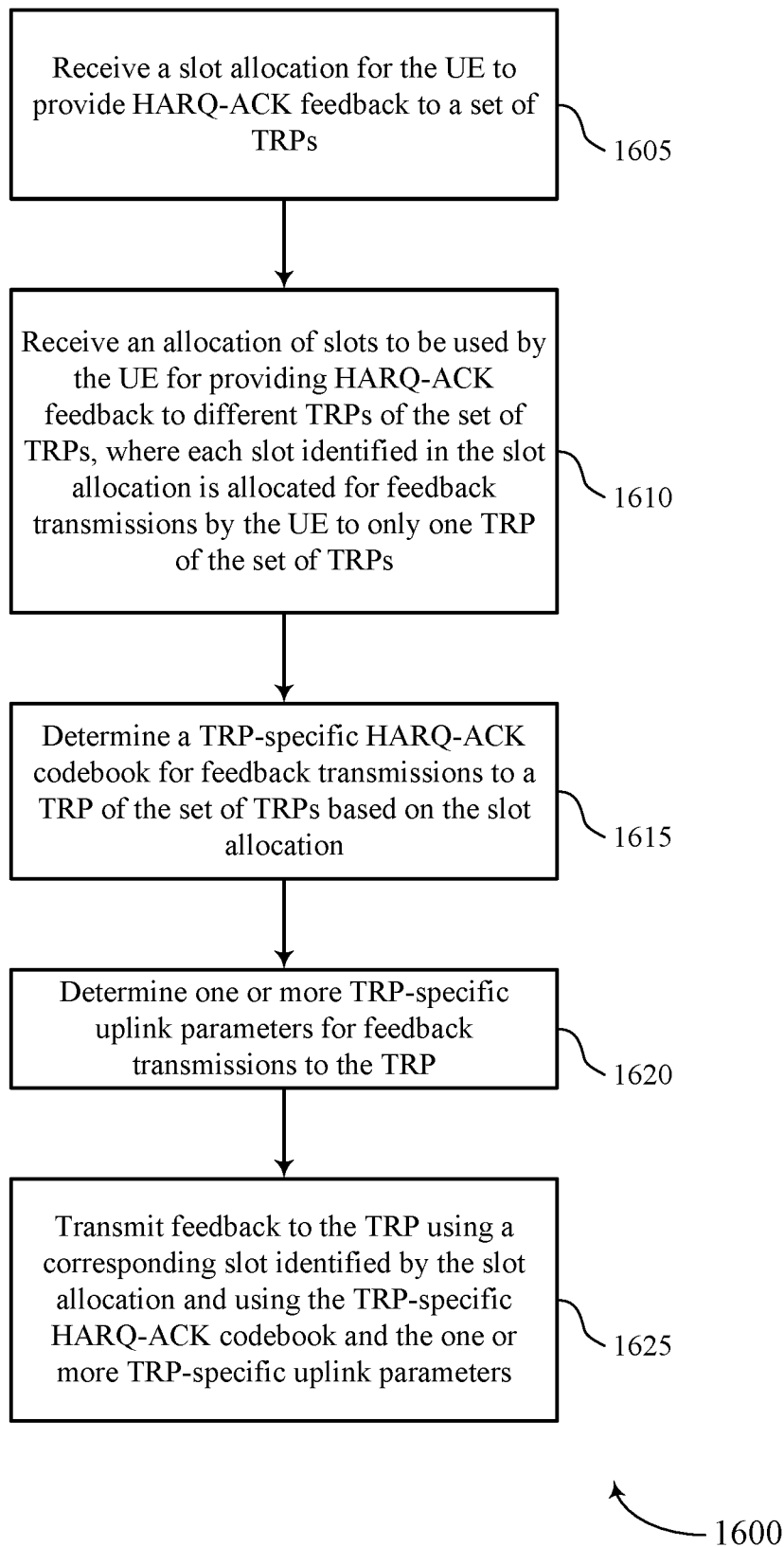

FIG. 16

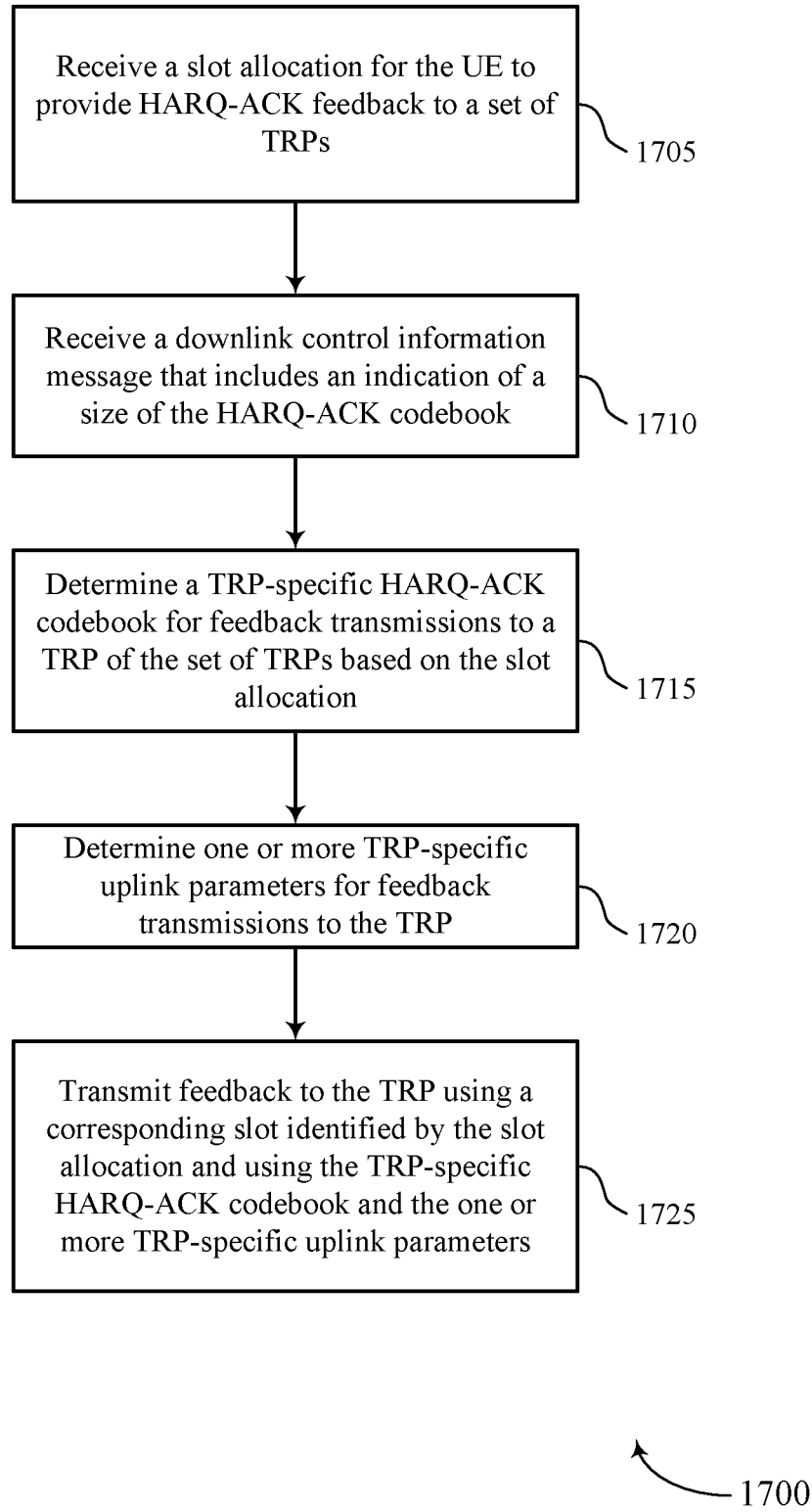

FIG. 17

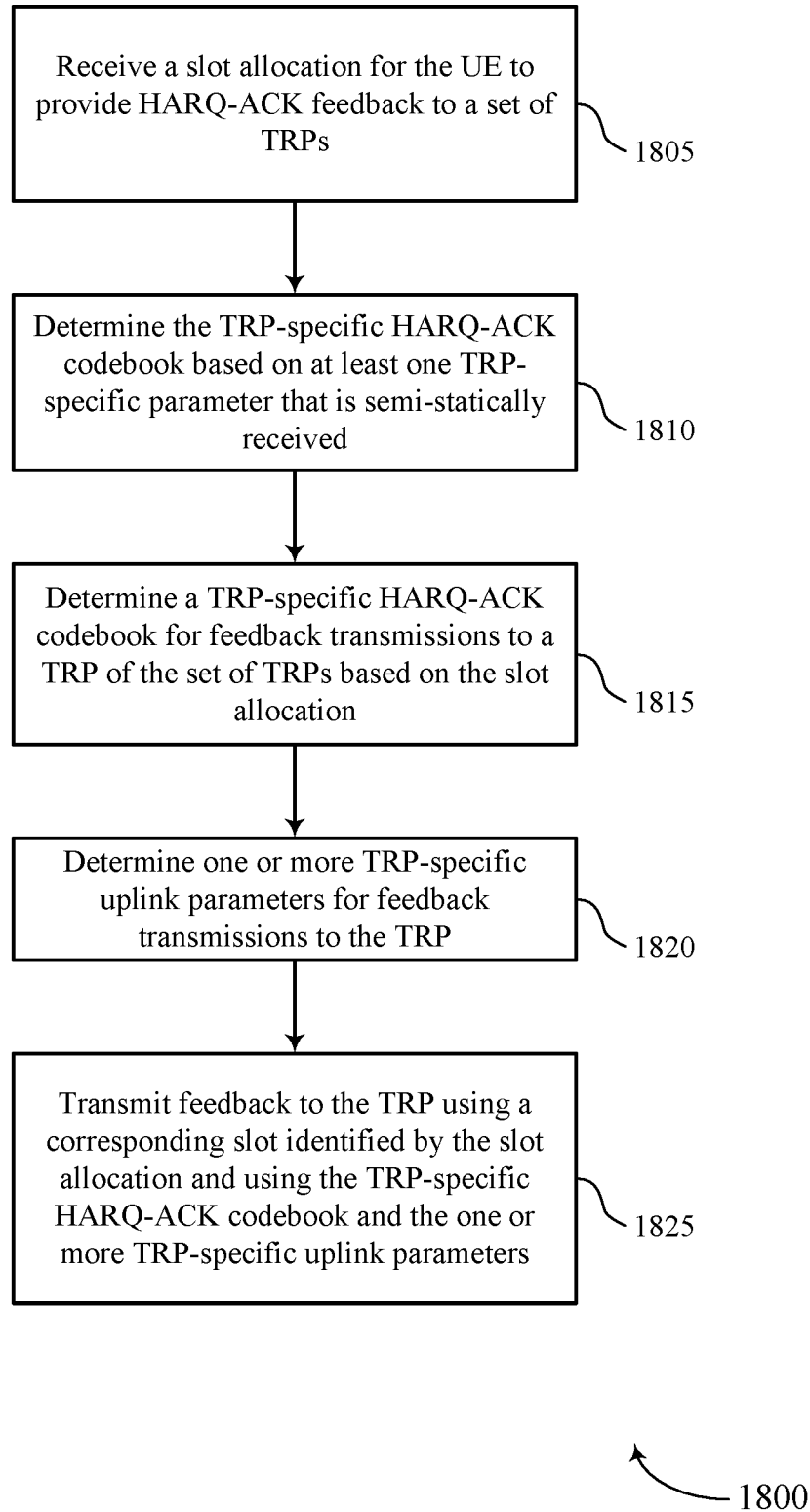

FIG. 18

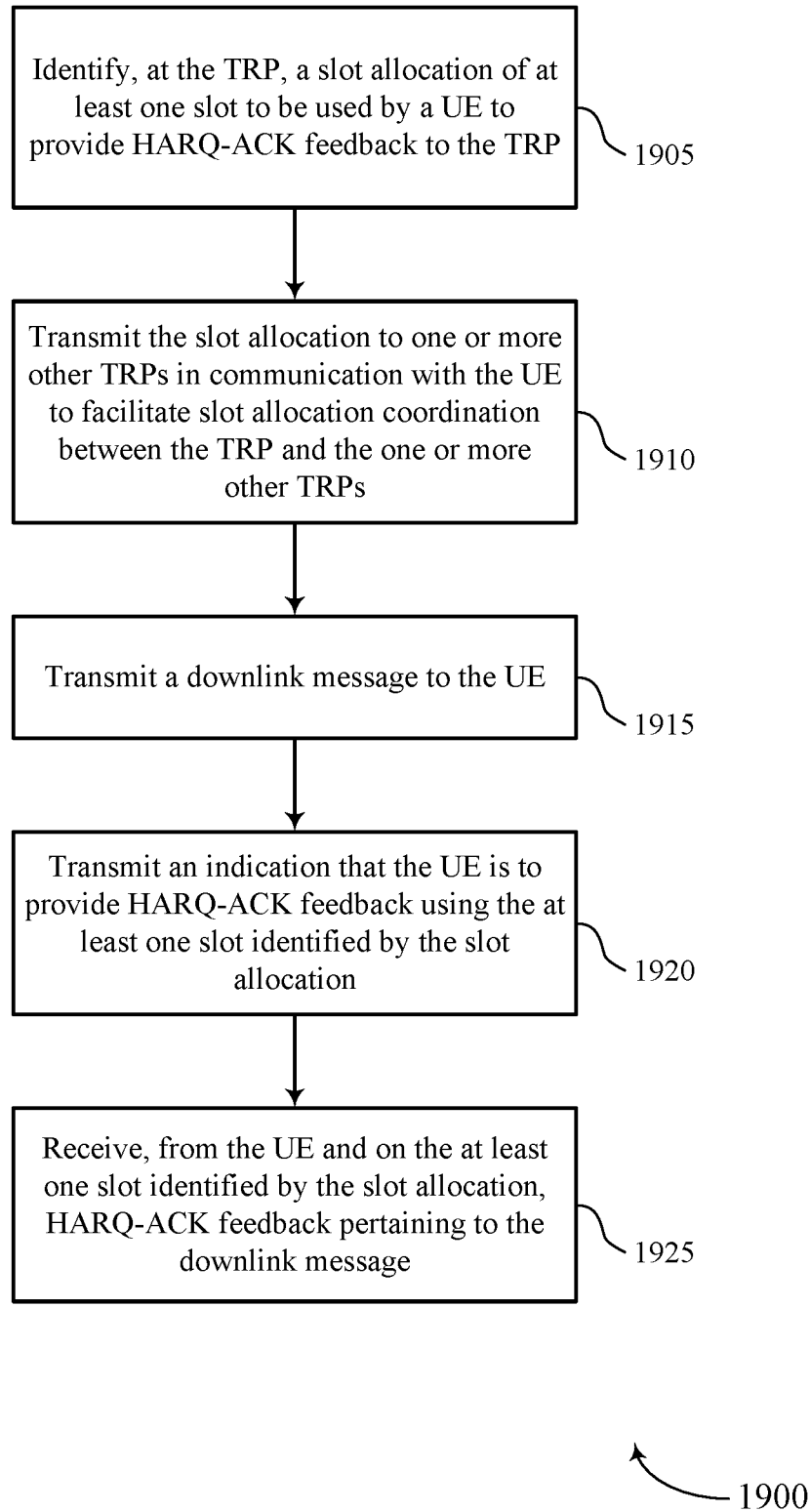
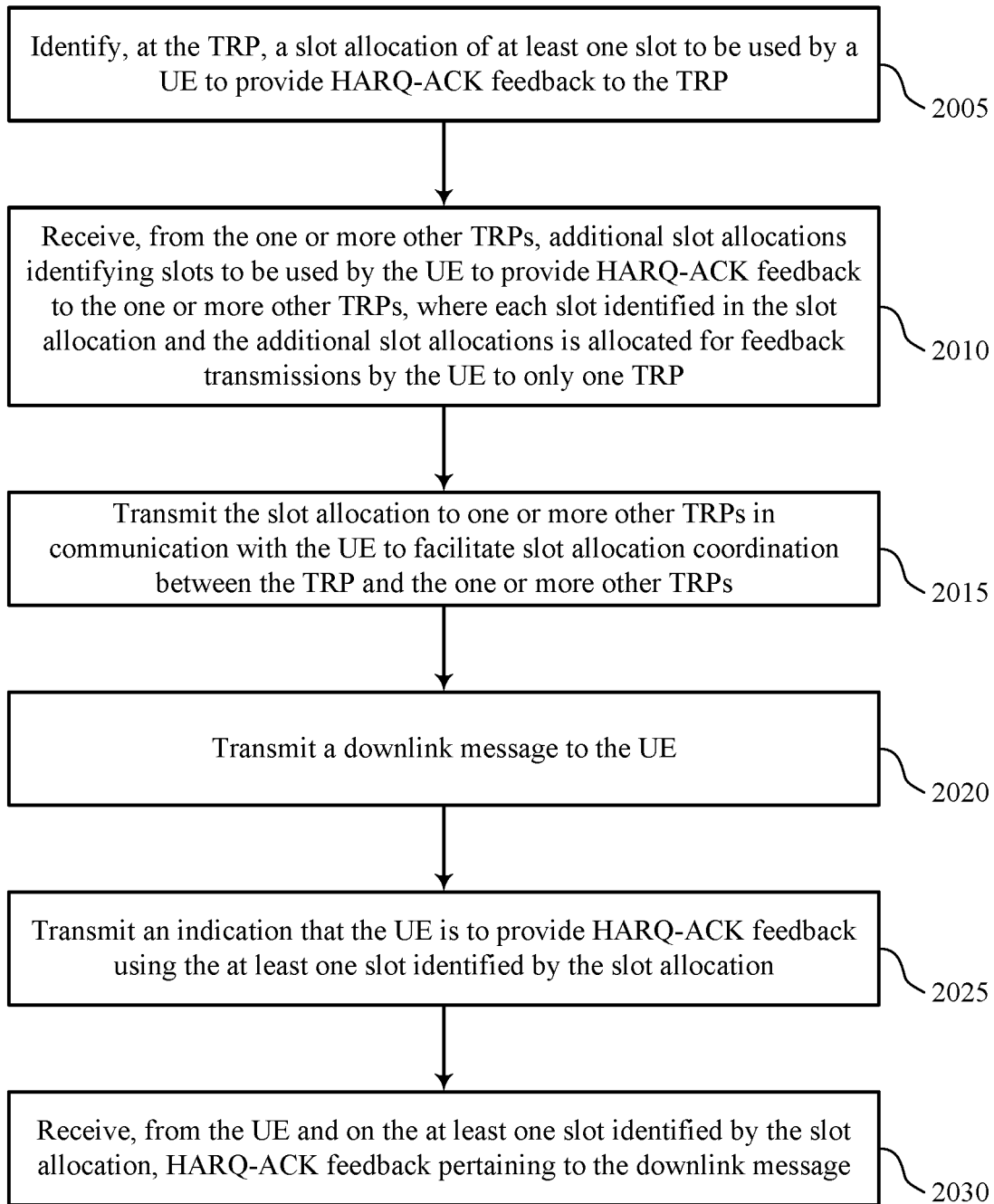

FIG. 19



2000

FIG. 20

**ACKNOWLEDGEMENT CODEBOOK
DESIGN FOR MULTIPLE TRANSMISSION
RECEPTION POINTS**

CROSS REFERENCE

[0001] The present application for patent claims the benefit of U.S. Provisional Patent Application No. 62/733,519 by YANG et al., entitled “ACKNOWLEDGEMENT CODEBOOK DESIGN FOR MULTIPLE TRANSMISSION RECEPTION POINTS,” filed Sep. 19, 2018, assigned to the assignee hereof, and expressly incorporated herein.

BACKGROUND

[0002] The following relates generally to wireless communications, and more specifically to acknowledgement (ACK) codebook design for multiple transmission reception points (TRPs).

[0003] Wireless communications systems are widely deployed to provide various types of communication content such as voice, video, packet data, messaging, broadcast, and so on. These systems may be capable of supporting communication with multiple users by sharing the available system resources (e.g., time, frequency, and power). Examples of such multiple-access systems include fourth generation (4G) systems such as Long Term Evolution (LTE) systems, LTE-Advanced (LTE-A) systems, or LTE-A Pro systems, and fifth generation (5G) systems which may be referred to as New Radio (NR) systems. These systems may employ technologies such as code division multiple access (CDMA), time division multiple access (TDMA), frequency division multiple access (FDMA), orthogonal frequency division multiple access (OFDMA), or discrete Fourier transform-spread-OFDM (DFT-S-OFDM). A wireless multiple-access communications system may include a number of base stations or network access nodes, each simultaneously supporting communication for multiple communication devices, which may be otherwise known as user equipment (UE).

[0004] In some wireless communications systems, a UE may communicate with multiple base stations and/or multiple cells on one or more base stations simultaneously. Each base station or cell on a base station may be referred to as a TRP. In some cases, the TRPs may coordinate semi-statically for different downlink and uplink transmission configurations due to a non-ideal backhaul connection between the TRPs. Accordingly, because of the non-ideal backhaul connection, each TRP may transmit separate downlink channel messages to the UE, and the UE may receive the separate downlink channel messages at approximately the same time. The UE may then be expected to transmit ACK feedback for each downlink channel message received. However, the UE may be unable to transmit multiple uplink messages at the same time (e.g., simultaneously). As such, efficient techniques are desired for transmitting ACK feedback to a TRP for a received downlink channel message.

SUMMARY

[0005] The described techniques relate to improved methods, systems, devices, and apparatuses that support an acknowledgement (ACK) codebook design for multiple transmission reception points (TRPs). Generally, the described techniques provide for a user equipment (UE)

receiving a slot allocation to provide hybrid automatic repeat request (HARQ) ACK feedback to multiple TRPs. For example, each TRP may be allocated at least one slot for HARQ-ACK feedback such that HARQ-ACK feedback for different TRPs may not be transmitted in a same slot. Additionally, the UE may determine a TRP-specific HARQ-ACK codebook for feedback transmissions to each TRP in their corresponding slots, where the TRP-specific HARQ-ACK codebook is determined based on a downlink control information (DCI) message and/or TRP-specific parameters. In some cases, the UE may also determine TRP-specific uplink parameters for the feedback transmissions to each TRP, where the TRP-specific uplink parameters may include quasi co-location (QCL) information, power control parameters, and timing advance (TA) parameters specific to each TRP. The UE may then transmit feedback to a TRP using a corresponding slot from the slot allocation and using the TRP-specific HARQ-ACK codebook and the TRP-specific uplink parameters. Additionally, if multiple downlink channel transmissions have a same ending orthogonal frequency-division multiplexing (OFDM) symbol, the UE may not be expected to receive more than one downlink channel transmission in a same slot from a same TRP or provide HARQ-ACK feedback for more than one downlink channel transmission in the same slot in a same HARQ-ACK feedback transmission.

[0006] A method of wireless communication at a UE is described. The method may include receiving a slot allocation for the UE to provide HARQ-ACK feedback to a set of TRPs, determining a TRP-specific HARQ-ACK codebook for feedback transmissions to a TRP of the set of TRPs based on the slot allocation, determining one or more TRP-specific uplink parameters for feedback transmissions to the TRP, and transmitting feedback to the TRP using a corresponding slot identified by the slot allocation and using the TRP-specific HARQ-ACK codebook and the one or more TRP-specific uplink parameters.

[0007] An apparatus for wireless communication at a UE is described. The apparatus may include a processor, memory coupled with the processor, and instructions stored in the memory. The instructions may be executable by the processor to cause the apparatus to receive a slot allocation for the UE to provide HARQ-ACK feedback to a set of TRPs, determine a TRP-specific HARQ-ACK codebook for feedback transmissions to a TRP of the set of TRPs based on the slot allocation, determine one or more TRP-specific uplink parameters for feedback transmissions to the TRP, and transmit feedback to the TRP using a corresponding slot identified by the slot allocation and using the TRP-specific HARQ-ACK codebook and the one or more TRP-specific uplink parameters.

[0008] Another apparatus for wireless communication at a UE is described. The apparatus may include means for receiving a slot allocation for the UE to provide HARQ-ACK feedback to a set of TRPs, determining a TRP-specific HARQ-ACK codebook for feedback transmissions to a TRP of the set of TRPs based on the slot allocation, determining one or more TRP-specific uplink parameters for feedback transmissions to the TRP, and transmitting feedback to the TRP using a corresponding slot identified by the slot allocation and using the TRP-specific HARQ-ACK codebook and the one or more TRP-specific uplink parameters.

[0009] A non-transitory computer-readable medium storing code for wireless communication at a UE is described.

The code may include instructions executable by a processor to receive a slot allocation for the UE to provide HARQ-ACK feedback to a set of TRPs, determine a TRP-specific HARQ-ACK codebook for feedback transmissions to a TRP of the set of TRPs based on the slot allocation, determine one or more TRP-specific uplink parameters for feedback transmissions to the TRP, and transmit feedback to the TRP using a corresponding slot identified by the slot allocation and using the TRP-specific HARQ-ACK codebook and the one or more TRP-specific uplink parameters.

[0010] In some examples of the method, apparatuses, and non-transitory computer-readable medium described herein, receiving the slot allocation may include operations, features, means, or instructions for receiving an allocation of slots to be used by the UE for providing HARQ-ACK feedback to different TRPs of the set of TRPs, where each slot identified in the slot allocation may be allocated for feedback transmissions by the UE to only one TRP of the set of TRPs.

[0011] In some examples of the method, apparatuses, and non-transitory computer-readable medium described herein, receiving the slot allocation may include operations, features, means, or instructions for receiving an allocation of slots to be used by the UE for providing HARQ-ACK feedback to different TRPs of the set of TRPs, where the slots may be allocated asymmetrically between the set of TRPs.

[0012] In some examples of the method, apparatuses, and non-transitory computer-readable medium described herein, determining the TRP-specific HARQ-ACK codebook may include operations, features, means, or instructions for receiving a DCI message that includes an indication of a size of the HARQ-ACK codebook.

[0013] In some examples of the method, apparatuses, and non-transitory computer-readable medium described herein, determining the TRP-specific HARQ-ACK codebook may include operations, features, means, or instructions for determining the TRP-specific HARQ-ACK codebook based on at least one TRP-specific parameter that may be semi-statically received.

[0014] In some examples of the method, apparatuses, and non-transitory computer-readable medium described herein, the at least one TRP-specific parameter may be one or more of a number of cells supported by the TRP for carrier aggregation (CA), a cell-specific uplink-downlink configuration associated with a cell of the TRP, a per-bandwidth part (BWP) table of time-domain resource allocation for physical downlink shared channels (PDSCHs) for the TRP, a per-BWP set of parameters defining PDSCH-to-feedback timing for the TRP, or a per-BWP PDSCH repetition factor for the TRP.

[0015] Some examples of the method, apparatuses, and non-transitory computer-readable medium described herein may further include operations, features, means, or instructions for identifying only one PDSCH reception opportunity per slot per cell from the TRP for time-domain resource allocations that overlap in time and receiving one PDSCH transmission from the TRP associated with the identified PDSCH reception opportunity, where the feedback to be transmitted in the corresponding slot includes feedback information pertaining to the one PDSCH reception or the PDSCH transmission.

[0016] Some examples of the method, apparatuses, and non-transitory computer-readable medium described herein

may further include operations, features, means, or instructions for receiving, from an additional TRP of the set of TRPs, an additional PDSCH, the additional PDSCH having a time-domain resource allocation in a same component carrier (CC) that overlaps with the PDSCH received from the TRP and transmitting the HARQ-ACK feedback to the additional TRP in a slot allocated for the additional TRP.

[0017] In some examples of the method, apparatuses, and non-transitory computer-readable medium described herein, determining the TRP-specific HARQ-ACK codebook may include operations, features, means, or instructions for comparing the slot allocation with a cell-specific uplink-downlink configuration associated with a cell of the TRP, where the feedback may be transmitted to the TRP using the corresponding slot only if the corresponding slot may be identified as an uplink slot by the cell-specific uplink-downlink configuration.

[0018] In some examples of the method, apparatuses, and non-transitory computer-readable medium described herein, determining the TRP-specific HARQ-ACK codebook may include operations, features, means, or instructions for comparing the slot allocation with a cell-specific uplink-downlink configuration associated with a cell of the TRP, where the feedback may be transmitted to the TRP using the corresponding slot only if symbols of the corresponding slot allocated for feedback transmission may be also allocated for uplink transmissions by the cell-specific uplink-downlink configuration.

[0019] Some examples of the method, apparatuses, and non-transitory computer-readable medium described herein may further include operations, features, means, or instructions for transmitting additional information to the TRP using the corresponding slot identified by the slot allocation.

[0020] In some examples of the method, apparatuses, and non-transitory computer-readable medium described herein, the additional information may be in the form of a physical uplink shared channel (PUSCH) payload, a scheduling request (SR), or a channel state information (CSI) report, and where the feedback may be combined with the additional information on a single uplink channel.

[0021] In some examples of the method, apparatuses, and non-transitory computer-readable medium described herein, transmitting feedback to the TRP using the corresponding slot may include operations, features, means, or instructions for transmitting the feedback via at least one of a physical uplink control channel (PUCCH) or as piggybacked uplink control information (UCI) via a PUSCH.

[0022] In some examples of the method, apparatuses, and non-transitory computer-readable medium described herein, the feedback transmitted to the TRP using the corresponding slot includes feedback information pertaining to only one PDSCH of multiple time-domain resource allocations having a same ending OFDM symbol.

[0023] In some examples of the method, apparatuses, and non-transitory computer-readable medium described herein, determining the one or more TRP-specific uplink parameters for feedback transmissions to the TRP may include operations, features, means, or instructions for identifying that QCL information may be configured for PUCCH transmissions and identifying TRP-specific QCL information for the TRP for the corresponding slot.

[0024] In some examples of the method, apparatuses, and non-transitory computer-readable medium described herein, determining the one or more TRP-specific uplink parameters

for feedback transmissions to the TRP may include operations, features, means, or instructions for identifying TRP-specific power control parameters for transmissions to the TRP for the corresponding slot.

[0025] In some examples of the method, apparatuses, and non-transitory computer-readable medium described herein, the TRP-specific power control parameters may include at least one of an open-loop power control parameter and a closed-loop power control parameter.

[0026] In some examples of the method, apparatuses, and non-transitory computer-readable medium described herein, determining the one or more TRP-specific uplink parameters for feedback transmissions to the TRP may include operations, features, means, or instructions for identifying TRP-specific TA parameters for transmissions to the TRP for the corresponding slot.

[0027] In some examples of the method, apparatuses, and non-transitory computer-readable medium described herein, receiving the slot allocation may include operations, features, means, or instructions for receiving the slot allocation via radio resource control (RRC) signaling.

[0028] Some examples of the method, apparatuses, and non-transitory computer-readable medium described herein may further include operations, features, means, or instructions for determining to transmit a set of HARQ acknowledgement feedback messages to the TRP of the set of TRPs, identifying a set of slots based on the slot allocation to transmit the set of HARQ acknowledgement feedback messages to the TRP, and transmitting the set of HARQ acknowledgement feedback messages to the TRP in the identified set of slots.

[0029] A method of wireless communication at a TRP is described. The method may include identifying, at the TRP, a slot allocation of at least one slot to be used by a UE to provide HARQ-ACK feedback to the TRP, transmitting a downlink message to the UE, transmitting an indication that the UE is to provide HARQ-ACK feedback using the at least one slot identified by the slot allocation, and receiving, from the UE and on the at least one slot identified by the slot allocation, HARQ-ACK feedback pertaining to the downlink message.

[0030] An apparatus for wireless communication at a TRP is described. The apparatus may include a processor, memory coupled with the processor, and instructions stored in the memory. The instructions may be executable by the processor to cause the apparatus to identify, at the TRP, a slot allocation of at least one slot to be used by a UE to provide HARQ-ACK feedback to the TRP, transmit a downlink message to the UE, transmit an indication that the UE is to provide HARQ-ACK feedback using the at least one slot identified by the slot allocation, and receive, from the UE and on the at least one slot identified by the slot allocation, HARQ-ACK feedback pertaining to the downlink message.

[0031] Another apparatus for wireless communication at a TRP is described. The apparatus may include means for identifying, at the TRP, a slot allocation of at least one slot to be used by a UE to provide HARQ-ACK feedback to the TRP, transmitting an indication that the UE is to provide HARQ-ACK feedback using the at least one slot identified by the slot allocation, and receiving, from the UE and on the at least one slot identified by the slot allocation, HARQ-ACK feedback pertaining to the downlink message.

[0032] A non-transitory computer-readable medium storing code for wireless communication at a TRP is described.

The code may include instructions executable by a processor to identify, at the TRP, a slot allocation of at least one slot to be used by a UE to provide HARQ-ACK feedback to the TRP, transmit a downlink message to the UE, transmit an indication that the UE is to provide HARQ-ACK feedback using the at least one slot identified by the slot allocation, and receive, from the UE and on the at least one slot identified by the slot allocation, HARQ-ACK feedback pertaining to the downlink message.

[0033] Some examples of the method, apparatuses, and non-transitory computer-readable medium described herein may further include operations, features, means, or instructions for transmitting the slot allocation to one or more other TRPs in communication with the UE to facilitate slot allocation coordination between the TRP and the one or more other TRPs, receiving, from the one or more other TRPs, additional slot allocations identifying slots to be used by the UE to provide HARQ-ACK feedback to the one or more other TRPs, where each slot identified in the slot allocation and the additional slot allocations may be allocated for feedback transmissions by the UE to only one TRP, or a combination thereof.

[0034] In some examples of the method, apparatuses, and non-transitory computer-readable medium described herein, the slots may be allocated asymmetrically between the TRP and the additional TRPs.

[0035] In some examples of the method, apparatuses, and non-transitory computer-readable medium described herein, transmitting the indication may include operations, features, means, or instructions for transmitting the indication via a DCI message.

[0036] Some examples of the method, apparatuses, and non-transitory computer-readable medium described herein may further include operations, features, means, or instructions for transmitting a DCI message that includes an indication of a size of a HARQ-ACK codebook to be used by the UE in providing feedback to the TRP.

[0037] Some examples of the method, apparatuses, and non-transitory computer-readable medium described herein may further include operations, features, means, or instructions for transmitting at least one semi-static TRP-specific parameter to the UE.

[0038] In some examples of the method, apparatuses, and non-transitory computer-readable medium described herein, the at least one TRP-specific parameter may be one or more of a number of cells supported by the TRP for CA, a cell-specific uplink-downlink configuration associated with a cell of the TRP, a per-BWP table of time-domain resource allocation for PDSCHs for the TRP, a per-BWP set of parameters defining PDSCH to feedback timing for the TRP, or a per-BWP PDSCH repetition factor for the TRP.

[0039] In some examples of the method, apparatuses, and non-transitory computer-readable medium described herein, receiving HARQ-ACK feedback pertaining to the downlink message may include operations, features, means, or instructions for receiving the HARQ-ACK feedback on the at least one slot identified by the slot allocation only if the at least one slot may be identified as an uplink slot by a cell-specific uplink-downlink configuration associated with the TRP.

[0040] In some examples of the method, apparatuses, and non-transitory computer-readable medium described herein, receiving HARQ-ACK feedback pertaining to the downlink message may include operations, features, means, or instructions for receiving the HARQ-ACK feedback on symbols of

the at least one slot identified by the slot allocation only if the symbols of the at least one slot may be allocated for uplink transmissions by a cell-specific uplink-downlink configuration associated with the TRP.

[0041] Some examples of the method, apparatuses, and non-transitory computer-readable medium described herein may further include operations, features, means, or instructions for receiving additional information from the UE using the at least one slot identified by the slot allocation.

[0042] In some examples of the method, apparatuses, and non-transitory computer-readable medium described herein, the additional information may be in the form of a PUSCH payload, an SR, or a CSI report, and where the HARQ-ACK feedback may be combined with the additional information on a single uplink channel.

[0043] In some examples of the method, apparatuses, and non-transitory computer-readable medium described herein, receiving HARQ-ACK feedback pertaining to the downlink message may include operations, features, means, or instructions for receiving the HARQ-ACK feedback via at least one of a PUCCH or as piggybacked UCI via a PUSCH.

[0044] In some examples of the method, apparatuses, and non-transitory computer-readable medium described herein, transmitting the downlink message to the UE may include operations, features, means, or instructions for transmitting only one PDSCH with a time-domain resource allocation having a same ending OFDM symbol per slot from the TRP.

[0045] In some examples of the method, apparatuses, and non-transitory computer-readable medium described herein, the HARQ-ACK feedback received from the UE in the at least one slot includes feedback information pertaining to only one PDSCH of multiple time-domain resource allocations having a same ending OFDM symbol.

[0046] Some examples of the method, apparatuses, and non-transitory computer-readable medium described herein may further include operations, features, means, or instructions for transmitting TRP-specific QCL information to the UE.

[0047] Some examples of the method, apparatuses, and non-transitory computer-readable medium described herein may further include operations, features, means, or instructions for transmitting TRP-specific power control parameters to the UE for transmissions to the TRP during the at least one slot.

[0048] Some examples of the method, apparatuses, and non-transitory computer-readable medium described herein may further include operations, features, means, or instructions for transmitting TRP-specific TA parameters to the UE for transmissions to the TRP during the at least one slot.

[0049] Some examples of the method, apparatuses, and non-transitory computer-readable medium described herein may further include operations, features, means, or instructions for transmitting the slot allocation via RRC signaling.

BRIEF DESCRIPTION OF THE DRAWINGS

[0050] FIG. 1 illustrates an example of a system for wireless communications that supports acknowledgement (ACK) codebook design for multiple transmission reception points (TRPs) in accordance with aspects of the present disclosure.

[0051] FIG. 2 illustrates an example of a wireless communications system that supports ACK codebook design for multiple TRPs in accordance with aspects of the present disclosure.

[0052] FIG. 3 illustrates an example of a slot allocation that supports ACK codebook design for multiple TRPs in accordance with aspects of the present disclosure.

[0053] FIG. 4 illustrates an example of a downlink channel schedule that supports ACK codebook design for multiple TRPs in accordance with aspects of the present disclosure.

[0054] FIG. 5 illustrates an example of an uplink channel repetition configuration that supports ACK codebook design for multiple TRPs in accordance with aspects of the present disclosure.

[0055] FIG. 6 illustrates an example of a process flow that supports ACK codebook design for multiple TRPs in accordance with aspects of the present disclosure.

[0056] FIGS. 7 and 8 show block diagrams of devices that support ACK codebook design for multiple TRPs in accordance with aspects of the present disclosure.

[0057] FIG. 9 shows a block diagram of a UE codebook manager that supports ACK codebook design for multiple TRPs in accordance with aspects of the present disclosure.

[0058] FIG. 10 shows a diagram of a system including a device that supports ACK codebook design for multiple TRPs in accordance with aspects of the present disclosure.

[0059] FIGS. 11 and 12 show block diagrams of devices that support ACK codebook design for multiple TRPs in accordance with aspects of the present disclosure.

[0060] FIG. 13 shows a block diagram of a TRP slot allocation manager that supports ACK codebook design for multiple TRPs in accordance with aspects of the present disclosure.

[0061] FIG. 14 shows a diagram of a system including a device that supports ACK codebook design for multiple TRPs in accordance with aspects of the present disclosure.

[0062] FIGS. 15 through 20 show flowcharts illustrating methods that support ACK codebook design for multiple TRPs in accordance with aspects of the present disclosure.

DETAILED DESCRIPTION

[0063] In some wireless communications systems, multiple transmission reception points (TRPs) may communicate with a same user equipment (UE) at the same or different time in a non-coherent manner (e.g., Non-Coherent Joint Transmission (NCJT)). For example, the multiple TRPs may be able to transmit physical downlink control channel (PDCCH) and/or physical downlink shared channel (PDSCH) messages to the UE (based on radio resource control (RRC) configuration). Additionally, the multiple TRPs may coordinate semi-statically with respect to different downlink channel, uplink channel, and reference signal (RS) configuration due to a non-ideal backhaul connection between the TRPs (e.g., an increased latency over the backhaul connection). Based on the non-ideal backhaul connection, the multiple TRPs may not be able to coordinate fast enough and, as such, may send separate PDCCH and PDSCH transmissions, where the UE may be expected to transmit hybrid automatic repeat request (HARQ) acknowledgement (ACK) feedback for each downlink transmission based on a HARQ-ACK codebook. However, while the UE may receive the multiple downlink transmissions simultaneously, the UE may be unable to transmit multiple uplink ACK feedback messages simultaneously.

[0064] To mitigate the need to transmit multiple uplink ACK feedback messages simultaneously, a scheduling TRP (e.g., a base station, the network, a giga-NodeB (gNB), etc.)

may configure the UE with a slot allocation for physical uplink control channel (PUCCH) feedback per TRP. For example, a first slot may be allocated for ACK feedback in a PUCCH to a first TRP, a second slot may be allocated for ACK feedback in a PUCCH to a second TRP, etc. Accordingly, ACK/negative ACK (NACK) feedback to different TRPs may not be transmitted within a same slot. The slot allocation may be explicitly indicated to the UE by the scheduling TRP, such that the UE knows which slot corresponds to which TRP and transmits the ACK/NACK feedback based on the slot/TRP configuration. Additionally, the UE may determine a different HARQ-ACK codebook for each slot/TRP based on each TRP having different parameters that are used for a codebook determination. In some cases, the UE may semi-statically determine the HARQ-ACK codebook for each TRP and use the respective HARQ-ACK codebook in each slot for the corresponding TRP. Additionally or alternatively, the HARQ-ACK codebook may be dynamically indicated by the scheduling TRP, where the scheduling TRP indicates the information to enable the UE to construct the HARQ-ACK codebook in each ACK feedback transmission. In some cases, quasi co-location (QCL), power control, and timing advance (TA) may also be specific to each slot/TRP.

[0065] Particular aspects of the subject matter described herein may be implemented to realize one or more advantages. The described techniques may support improvements in transmitting ACK feedback to a TRP for a received downlink channel message, decreasing signaling overhead, and improving reliability, among other advantages. As such, supported techniques may include improved network operations and, in some examples, may promote network efficiencies, among other benefits.

[0066] Aspects of the disclosure are initially described in the context of a wireless communications system. An additional wireless communications system, a slot allocation, a downlink channel schedule, an uplink channel repetition configuration, and a process flow are then provided to illustrate aspects of the disclosure. Aspects of the disclosure are further illustrated by and described with reference to apparatus diagrams, system diagrams, and flowcharts that relate to ACK codebook design for multiple TRPs.

[0067] FIG. 1 illustrates an example of a wireless communications system 100 that supports ACK codebook design for multiple TRPs in accordance with aspects of the present disclosure. The wireless communications system 100 includes base stations 105, UEs 115, and a core network 130. In some examples, the wireless communications system 100 may be a Long Term Evolution (LTE) network, an LTE-Advanced (LTE-A) network, an LTE-A Pro network, or a New Radio (NR) network. In some cases, wireless communications system 100 may support enhanced broadband communications, ultra-reliable (e.g., mission critical) communications, low latency communications, or communications with low-cost and low-complexity devices.

[0068] Base stations 105 may wirelessly communicate with UEs 115 via one or more base station antennas. Base stations 105 described herein may include or may be referred to by those skilled in the art as a base transceiver station, a radio base station, an access point, a radio transceiver, a NodeB, an eNodeB (eNB), a next-generation Node B or giga-nodeB (either of which may be referred to as a gNB), a Home NodeB, a Home eNodeB, or some other suitable terminology. Wireless communications system 100

may include base stations 105 of different types (e.g., macro or small cell base stations). The UEs 115 described herein may be able to communicate with various types of base stations 105 and network equipment including macro eNBs, small cell eNBs, gNBs, relay base stations, and the like.

[0069] Each base station 105 may be associated with a particular geographic coverage area 110 in which communications with various UEs 115 is supported. Each base station 105 may provide communication coverage for a respective geographic coverage area 110 via communication links 125, and communication links 125 between a base station 105 and a UE 115 may utilize one or more carriers. Communication links 125 shown in wireless communications system 100 may include uplink transmissions from a UE 115 to a base station 105, or downlink transmissions from a base station 105 to a UE 115. Downlink transmissions may also be called forward link transmissions while uplink transmissions may also be called reverse link transmissions.

[0070] The geographic coverage area 110 for a base station 105 may be divided into sectors making up only a portion of the geographic coverage area 110, and each sector may be associated with a cell. For example, each base station 105 may provide communication coverage for a macro cell, a small cell, a hot spot, or other types of cells, or various combinations thereof. In some examples, a base station 105 may be movable and therefore provide communication coverage for a moving geographic coverage area 110. In some examples, different geographic coverage areas 110 associated with different technologies may overlap, and overlapping geographic coverage areas 110 associated with different technologies may be supported by the same base station 105 or by different base stations 105. The wireless communications system 100 may include, for example, a heterogeneous LTE/LTE-A/LTE-A Pro or NR network in which different types of base stations 105 provide coverage for various geographic coverage areas 110.

[0071] The term “cell” refers to a logical communication entity used for communication with a base station 105 (e.g., over a carrier), and may be associated with an identifier for distinguishing neighboring cells (e.g., a physical cell identifier (PCID), a virtual cell identifier (VCID)) operating via the same or a different carrier. In some examples, a carrier may support multiple cells, and different cells may be configured according to different protocol types (e.g., machine-type communication (MTC), narrowband Internet-of-Things (NB-IoT), enhanced mobile broadband (eMBB), or others) that may provide access for different types of devices. In some cases, the term “cell” may refer to a portion of a geographic coverage area 110 (e.g., a sector) over which the logical entity operates.

[0072] UEs 115 may be dispersed throughout the wireless communications system 100, and each UE 115 may be stationary or mobile. A UE 115 may also be referred to as a mobile device, a wireless device, a remote device, a handheld device, or a subscriber device, or some other suitable terminology, where the “device” may also be referred to as a unit, a station, a terminal, or a client. A UE 115 may be a personal electronic device such as a cellular phone, a personal digital assistant (PDA), a tablet computer, a laptop computer, or a personal computer. In some examples, a UE 115 may also refer to a wireless local loop (WLL) station, an Internet of Things (IoT) device, an Internet of Everything

(IoT) device, or an MTC device, or the like, which may be implemented in various articles such as appliances, vehicles, meters, or the like.

[0073] Some UEs **115**, such as MTC or IoT devices, may be low cost or low complexity devices, and may provide for automated communication between machines (e.g., via Machine-to-Machine (M2M) communication). M2M communication or MTC may refer to data communication technologies that allow devices to communicate with one another or a base station **105** without human intervention. In some examples, M2M communication or MTC may include communications from devices that integrate sensors or meters to measure or capture information and relay that information to a central server or application program that can make use of the information or present the information to humans interacting with the program or application. Some UEs **115** may be designed to collect information or enable automated behavior of machines. Examples of applications for MTC devices include smart metering, inventory monitoring, water level monitoring, equipment monitoring, healthcare monitoring, wildlife monitoring, weather and geological event monitoring, fleet management and tracking, remote security sensing, physical access control, and transaction-based business charging.

[0074] Some UEs **115** may be configured to employ operating modes that reduce power consumption, such as half-duplex communications (e.g., a mode that supports one-way communication via transmission or reception, but not transmission and reception simultaneously). In some examples half-duplex communications may be performed at a reduced peak rate. Other power conservation techniques for UEs **115** include entering a power saving “deep sleep” mode when not engaging in active communications, or operating over a limited bandwidth (e.g., according to narrowband communications). In some cases, UEs **115** may be designed to support critical functions (e.g., mission critical functions), and a wireless communications system **100** may be configured to provide ultra-reliable communications for these functions.

[0075] In some cases, a UE **115** may also be able to communicate directly with other UEs **115** (e.g., using a peer-to-peer (P2P) or device-to-device (D2D) protocol). One or more of a group of UEs **115** utilizing D2D communications may be within the geographic coverage area **110** of a base station **105**. Other UEs **115** in such a group may be outside the geographic coverage area **110** of a base station **105**, or be otherwise unable to receive transmissions from a base station **105**. In some cases, groups of UEs **115** communicating via D2D communications may utilize a one-to-many (1:M) system in which each UE **115** transmits to every other UE **115** in the group. In some cases, a base station **105** facilitates the scheduling of resources for D2D communications. In other cases, D2D communications are carried out between UEs **115** without the involvement of a base station **105**.

[0076] Base stations **105** may communicate with the core network **130** and with one another. For example, base stations **105** may interface with the core network **130** through backhaul links **132** (e.g., via an S1, N2, N3, or other interface). Base stations **105** may communicate with one another over backhaul links **134** (e.g., via an X2, Xn, or other interface) either directly (e.g., directly between base stations **105**) or indirectly (e.g., via core network **130**).

[0077] The core network **130** may provide user authentication, access authorization, tracking, Internet Protocol (IP) connectivity, and other access, routing, or mobility functions. The core network **130** may be an evolved packet core (EPC), which may include at least one mobility management entity (MME), at least one serving gateway (S-GW), and at least one Packet Data Network (PDN) gateway (P-GW). The MME may manage non-access stratum (e.g., control plane) functions such as mobility, authentication, and bearer management for UEs **115** served by base stations **105** associated with the EPC. User IP packets may be transferred through the S-GW, which itself may be connected to the P-GW. The P-GW may provide IP address allocation as well as other functions. The P-GW may be connected to the network operators IP services. The operators IP services may include access to the Internet, Intranet(s), an IP Multimedia Subsystem (IMS), or a Packet-Switched (PS) Streaming Service.

[0078] At least some of the network devices, such as a base station **105**, may include subcomponents such as an access network entity, which may be an example of an access node controller (ANC). Each access network entity may communicate with UEs **115** through a number of other access network transmission entities, which may be referred to as a radio head, a smart radio head, or a TRP. In some configurations, various functions of each access network entity or base station **105** may be distributed across various network devices (e.g., radio heads and access network controllers) or consolidated into a single network device (e.g., a base station **105**). Additionally or alternatively, a base station **105** as described herein may be referred to as a TRP **105**.

[0079] Wireless communications system **100** may operate using one or more frequency bands, typically in the range of 300 MHz to 300 GHz. Generally, the region from 300 MHz to 3 GHz is known as the ultra-high frequency (UHF) region or decimeter band, since the wavelengths range from approximately one decimeter to one meter in length. UHF waves may be blocked or redirected by buildings and environmental features. However, the waves may penetrate structures sufficiently for a macro cell to provide service to UEs **115** located indoors. Transmission of UHF waves may be associated with smaller antennas and shorter range (e.g., less than 100 km) compared to transmission using the smaller frequencies and longer waves of the high frequency (HF) or very high frequency (VHF) portion of the spectrum below 300 MHz.

[0080] Wireless communications system **100** may also operate in a super high frequency (SHF) region using frequency bands from 3 GHz to 30 GHz, also known as the centimeter band. The SHF region includes bands such as the 5 GHz industrial, scientific, and medical (ISM) bands, which may be used opportunistically by devices that can tolerate interference from other users.

[0081] Wireless communications system **100** may also operate in an extremely high frequency (EHF) region of the spectrum (e.g., from 30 GHz to 300 GHz), also known as the millimeter band. In some examples, wireless communications system **100** may support millimeter wave (mmW) communications between UEs **115** and base stations **105**, and EHF antennas of the respective devices may be even smaller and more closely spaced than UHF antennas. In some cases, this may facilitate use of antenna arrays within a UE **115**. However, the propagation of EHF transmissions may be subject to even greater atmospheric attenuation and

shorter range than SHF or UHF transmissions. Techniques disclosed herein may be employed across transmissions that use one or more different frequency regions, and designated use of bands across these frequency regions may differ by country or regulating body.

[0082] In some cases, wireless communications system **100** may utilize both licensed and unlicensed radio frequency spectrum bands. For example, wireless communications system **100** may employ License Assisted Access (LAA), LTE-Unlicensed (LTE-U) radio access technology, or NR technology in an unlicensed band such as the 5 GHz ISM band. When operating in unlicensed radio frequency spectrum bands, wireless devices such as base stations **105** and UEs **115** may employ listen-before-talk (LBT) procedures to ensure a frequency channel is clear before transmitting data. In some cases, operations in unlicensed bands may be based on a CA configuration in conjunction with CCs operating in a licensed band (e.g., LAA). Operations in unlicensed spectrum may include downlink transmissions, uplink transmissions, peer-to-peer transmissions, or a combination of these. Duplexing in unlicensed spectrum may be based on frequency division duplexing (FDD), time division duplexing (TDD), or a combination of both.

[0083] In some examples, base station **105** or UE **115** may be equipped with multiple antennas, which may be used to employ techniques such as transmit diversity, receive diversity, multiple-input multiple-output (MIMO) communications, or beamforming. For example, wireless communications system **100** may use a transmission scheme between a transmitting device (e.g., a base station **105**) and a receiving device (e.g., a UE **115**), where the transmitting device is equipped with multiple antennas and the receiving devices are equipped with one or more antennas. MIMO communications may employ multipath signal propagation to increase the spectral efficiency by transmitting or receiving multiple signals via different spatial layers, which may be referred to as spatial multiplexing. The multiple signals may, for example, be transmitted by the transmitting device via different antennas or different combinations of antennas. Likewise, the multiple signals may be received by the receiving device via different antennas or different combinations of antennas. Each of the multiple signals may be referred to as a separate spatial stream and may carry bits associated with the same data stream (e.g., the same code-word) or different data streams. Different spatial layers may be associated with different antenna ports used for channel measurement and reporting. MIMO techniques include single-user MIMO (SU-MIMO) where multiple spatial layers are transmitted to the same receiving device, and multiple-user MIMO (MU-MIMO) where multiple spatial layers are transmitted to multiple devices.

[0084] Beamforming, which may also be referred to as spatial filtering, directional transmission, or directional reception, is a signal processing technique that may be used at a transmitting device or a receiving device (e.g., a base station **105** or a UE **115**) to shape or steer an antenna beam (e.g., a transmit beam or receive beam) along a spatial path between the transmitting device and the receiving device. Beamforming may be achieved by combining the signals communicated via antenna elements of an antenna array such that signals propagating at particular orientations with respect to an antenna array experience constructive interference while others experience destructive interference. The adjustment of signals communicated via the antenna ele-

ments may include a transmitting device or a receiving device applying certain amplitude and phase offsets to signals carried via each of the antenna elements associated with the device. The adjustments associated with each of the antenna elements may be defined by a beamforming weight set associated with a particular orientation (e.g., with respect to the antenna array of the transmitting device or receiving device, or with respect to some other orientation).

[0085] In one example, a base station **105** may use multiple antennas or antenna arrays to conduct beamforming operations for directional communications with a UE **115**. For instance, some signals (e.g., synchronization signals, reference signals, beam selection signals, or other control signals) may be transmitted by a base station **105** multiple times in different directions, which may include a signal being transmitted according to different beamforming weight sets associated with different directions of transmission. Transmissions in different beam directions may be used to identify (e.g., by the base station **105** or a receiving device, such as a UE **115**) a beam direction for subsequent transmission and/or reception by the base station **105**. Some signals, such as data signals associated with a particular receiving device, may be transmitted by a base station **105** in a single beam direction (e.g., a direction associated with the receiving device, such as a UE **115**). In some examples, the beam direction associated with transmissions along a single beam direction may be determined based at least in part on a signal that was transmitted in different beam directions. For example, a UE **115** may receive one or more of the signals transmitted by the base station **105** in different directions, and the UE **115** may report to the base station **105** an indication of the signal it received with a highest signal quality, or an otherwise acceptable signal quality. Although these techniques are described with reference to signals transmitted in one or more directions by a base station **105**, a UE **115** may employ similar techniques for transmitting signals multiple times in different directions (e.g., for identifying a beam direction for subsequent transmission or reception by the UE **115**), or transmitting a signal in a single direction (e.g., for transmitting data to a receiving device).

[0086] A receiving device (e.g., a UE **115**, which may be an example of a mmW receiving device) may try multiple receive beams when receiving various signals from the base station **105**, such as synchronization signals, reference signals, beam selection signals, or other control signals. For example, a receiving device may try multiple receive directions by receiving via different antenna subarrays, by processing received signals according to different antenna subarrays, by receiving according to different receive beamforming weight sets applied to signals received at a plurality of antenna elements of an antenna array, or by processing received signals according to different receive beamforming weight sets applied to signals received at a plurality of antenna elements of an antenna array, any of which may be referred to as “listening” according to different receive beams or receive directions. In some examples a receiving device may use a single receive beam to receive along a single beam direction (e.g., when receiving a data signal). The single receive beam may be aligned in a beam direction determined based at least in part on listening according to different receive beam directions (e.g., a beam direction determined to have a highest signal strength,

highest signal-to-noise ratio, or otherwise acceptable signal quality based at least in part on listening according to multiple beam directions).

[0087] In some cases, the antennas of a base station **105** or UE **115** may be located within one or more antenna arrays, which may support MIMO operations, or transmit or receive beamforming. For example, one or more base station antennas or antenna arrays may be co-located at an antenna assembly, such as an antenna tower. In some cases, antennas or antenna arrays associated with a base station **105** may be located in diverse geographic locations. A base station **105** may have an antenna array with a number of rows and columns of antenna ports that the base station **105** may use to support beamforming of communications with a UE **115**. Likewise, a UE **115** may have one or more antenna arrays that may support various MIMO or beamforming operations.

[0088] In some cases, wireless communications system **100** may be a packet-based network that operate according to a layered protocol stack. In the user plane, communications at the bearer or Packet Data Convergence Protocol (PDCP) layer may be IP-based. A Radio Link Control (RLC) layer may in some cases perform packet segmentation and reassembly to communicate over logical channels. A Medium Access Control (MAC) layer may perform priority handling and multiplexing of logical channels into transport channels. The MAC layer may also use HARQ to provide retransmission at the MAC layer to improve link efficiency. In the control plane, the RRC protocol layer may provide establishment, configuration, and maintenance of an RRC connection between a UE **115** and a base station **105** or core network **130** supporting radio bearers for user plane data. At the Physical (PHY) layer, transport channels may be mapped to physical channels.

[0089] In some cases, UEs **115** and base stations **105** may support retransmissions of data to increase the likelihood that data is received successfully. HARQ feedback is one technique of increasing the likelihood that data is received correctly over a communication link **125**. HARQ may include a combination of error detection (e.g., using a cyclic redundancy check (CRC)), forward error correction (FEC), and retransmission (e.g., automatic repeat request (ARQ)). HARQ may improve throughput at the MAC layer in poor radio conditions (e.g., signal-to-noise conditions). In some cases, a wireless device may support same-slot HARQ feedback, where the device may provide HARQ feedback in a specific slot for data received in a previous symbol in the slot. In other cases, the device may provide HARQ feedback in a subsequent slot, or according to some other time interval.

[0090] Time intervals in LTE or NR may be expressed in multiples of a basic time unit, which may, for example, refer to a sampling period of $T_s=1/30,720,000$ seconds. Time intervals of a communications resource may be organized according to radio frames each having a duration of 10 milliseconds (ms), where the frame period may be expressed as $T_f=307,200 T_s$. The radio frames may be identified by a system frame number (SFN) ranging from 0 to 1023. Each frame may include 10 subframes numbered from 0 to 9, and each subframe may have a duration of 1 ms. A subframe may be further divided into 2 slots each having a duration of 0.5 ms, and each slot may contain 6 or 7 modulation symbol periods (e.g., depending on the length of the cyclic prefix prepended to each symbol period). Excluding the cyclic

prefix, each symbol period may contain 2048 sampling periods. In some cases, a subframe may be the smallest scheduling unit of the wireless communications system **100**, and may be referred to as a transmission time interval (TTI). In other cases, a smallest scheduling unit of the wireless communications system **100** may be shorter than a subframe or may be dynamically selected (e.g., in bursts of shortened TTIs (sTTIs) or in selected component carriers using sTTIs).

[0091] In some wireless communications systems, a slot may further be divided into multiple mini-slots containing one or more symbols. In some instances, a symbol of a mini-slot or a mini-slot may be the smallest unit of scheduling. Each symbol may vary in duration depending on the subcarrier spacing or frequency band of operation, for example. Further, some wireless communications systems may implement slot aggregation in which multiple slots or mini-slots are aggregated together and used for communication between a UE **115** and a base station **105**.

[0092] The term “carrier” refers to a set of radio frequency spectrum resources having a defined physical layer structure for supporting communications over a communication link **125**. For example, a carrier of a communication link **125** may include a portion of a radio frequency spectrum band that is operated according to physical layer channels for a given radio access technology. Each physical layer channel may carry user data, control information, or other signaling. A carrier may be associated with a pre-defined frequency channel (e.g., an E-UTRA absolute radio frequency channel number (EARFCN)) and may be positioned according to a channel raster for discovery by UEs **115**. Carriers may be downlink or uplink (e.g., in an FDD mode), or be configured to carry downlink and uplink communications (e.g., in a TDD mode). In some examples, signal waveforms transmitted over a carrier may be made up of multiple sub-carriers (e.g., using multi-carrier modulation (MCM) techniques such as orthogonal frequency-division multiplexing (OFDM) or discrete Fourier transform-spread-OFDM (DFT-s-OFDM)).

[0093] The organizational structure of the carriers may be different for different radio access technologies (e.g., LTE, LTE-A, LTE-A Pro, NR, etc.). For example, communications over a carrier may be organized according to TTIs or slots, each of which may include user data as well as control information or signaling to support decoding the user data. A carrier may also include dedicated acquisition signaling (e.g., synchronization signals or system information, etc.) and control signaling that coordinates operation for the carrier. In some examples (e.g., in a carrier aggregation configuration), a carrier may also have acquisition signaling or control signaling that coordinates operations for other carriers.

[0094] Physical channels may be multiplexed on a carrier according to various techniques. A physical control channel and a physical data channel may be multiplexed on a downlink carrier, for example, using time division multiplexing (TDM) techniques, frequency division multiplexing (FDM) techniques, or hybrid TDM-FDM techniques. In some examples, control information transmitted in a physical control channel may be distributed between different control regions in a cascaded manner (e.g., between a common control region or common search space and one or more UE-specific control regions or UE-specific search spaces).

[0095] A carrier may be associated with a particular bandwidth of the radio frequency spectrum, and in some examples the carrier bandwidth may be referred to as a “system bandwidth” of the carrier or the wireless communications system **100**. For example, the carrier bandwidth may be one of a number of predetermined bandwidths for carriers of a particular radio access technology (e.g., 1.4, 3, 5, 10, 15, 20, 40, or 80 MHz). In some examples, each served UE **115** may be configured for operating over portions or all of the carrier bandwidth. In other examples, some UEs **115** may be configured for operation using a narrowband protocol type that is associated with a predefined portion or range (e.g., set of subcarriers or RBs) within a carrier (e.g., “in-band” deployment of a narrowband protocol type).

[0096] In a system employing MCM techniques, a resource element may consist of one symbol period (e.g., a duration of one modulation symbol) and one subcarrier, where the symbol period and subcarrier spacing are inversely related. The number of bits carried by each resource element may depend on the modulation scheme (e.g., the order of the modulation scheme). Thus, the more resource elements that a UE **115** receives and the higher the order of the modulation scheme, the higher the data rate may be for the UE **115**. In MIMO systems, a wireless communications resource may refer to a combination of a radio frequency spectrum resource, a time resource, and a spatial resource (e.g., spatial layers), and the use of multiple spatial layers may further increase the data rate for communications with a UE **115**.

[0097] Devices of the wireless communications system **100** (e.g., base stations **105** or UEs **115**) may have a hardware configuration that supports communications over a particular carrier bandwidth or may be configurable to support communications over one of a set of carrier bandwidths. In some examples, the wireless communications system **100** may include base stations **105** and/or UEs **115** that can support simultaneous communications via carriers associated with more than one different carrier bandwidth.

[0098] Wireless communications system **100** may support communication with a UE **115** on multiple cells or carriers, a feature which may be referred to as carrier aggregation (CA) or multi-carrier operation. A UE **115** may be configured with multiple downlink component carriers (CCs) and one or more uplink CCs according to a carrier aggregation configuration. Carrier aggregation may be used with both FDD and TDD component carriers.

[0099] In some cases, wireless communications system **100** may utilize enhanced component carriers (eCCs). An eCC may be characterized by one or more features including wider carrier or frequency channel bandwidth, shorter symbol duration, shorter TTI duration, or modified control channel configuration. In some cases, an eCC may be associated with a carrier aggregation configuration or a dual connectivity configuration (e.g., when multiple serving cells have a suboptimal or non-ideal backhaul link). An eCC may also be configured for use in unlicensed spectrum or shared spectrum (e.g., where more than one operator is allowed to use the spectrum). An eCC characterized by wide carrier bandwidth may include one or more segments that may be utilized by UEs **115** that are not capable of monitoring the whole carrier bandwidth or are otherwise configured to use a limited carrier bandwidth (e.g., to conserve power).

[0100] In some cases, an eCC may utilize a different symbol duration than other CCs, which may include use of a reduced symbol duration as compared with symbol durations of the other CCs. A shorter symbol duration may be associated with increased spacing between adjacent subcarriers. A device, such as a UE **115** or base station **105**, utilizing eCCs may transmit wideband signals (e.g., according to frequency channel or carrier bandwidths of 20, 40, 60, 80 MHz, etc.) at reduced symbol durations (e.g., 16.67 microseconds). A TTI in eCC may consist of one or multiple symbol periods. In some cases, the TTI duration (that is, the number of symbol periods in a TTI) may be variable.

[0101] Wireless communications systems such as an NR system may utilize any combination of licensed, shared, and unlicensed spectrum bands, among others. The flexibility of eCC symbol duration and subcarrier spacing may allow for the use of eCC across multiple spectrums. In some examples, NR shared spectrum may increase spectrum utilization and spectral efficiency, specifically through dynamic vertical (e.g., across the frequency domain) and horizontal (e.g., across the time domain) sharing of resources.

[0102] In some wireless communications systems, a UE **115** may communicate with one or more TRPs **105** (e.g., base stations **105**) using a NCJT scheme. The NCJT scheme may enable joint transmissions (JTs) to the multiple TRPs **105**. Various NCJT techniques may have a lower requirement for the backhaul speed, capacity, latency, etc., between TRPs **105**, and may allow transmissions to or from each TRP **105** as independent data streams. A TRP **105** may indicate an NCJT mode for the UE **115** to receive corresponding JTs from the TRP **105** and other TRPs **105**. The UE **115** may then receive the downlink JTs based on the indicated NCJT mode from each TRP **105** simultaneously, where the downlink JTs may be PDCCH or PDSCH transmissions to the UE **115** from the TRPs **105** (e.g., based on an RRC configuration). In some cases, the downlink JTs may indicate for the UE **115** to transmit uplink information in response to the downlink JTs. For example, the UE **115** may be expected to transmit HARQ-ACK feedback to respective TRPs **105** after receiving the downlink JTs to indicate whether the downlink JTs were successfully received and decoded (e.g., ACK indicates a successful reception and decoding, while a NACK indicates an unsuccessful reception and/or decoding).

[0103] The multiple TRPs **105** may coordinate semi-statically with respect to PDSCH, PDCCH, physical uplink control channel (PUCCH), physical uplink shared channel (PUSCH), and/or RS configurations due to a non-ideal backhaul between the TRPs **105**. The non-ideal backhaul may indicate a level of delay for communications between the TRPs **105** (e.g., greater than five (5) ms) and a limited capacity for the backhaul link **132**. Additionally, the non-ideal backhaul condition may imply that each TRP **105** sends a separate PDCCH and PDSCH to the UE **115**, where the PDCCHs may appear in different control resource sets (CORESETs) within a same slot and the PDSCHs may appear in a same slot. As such, as noted above, the UE **115** may transmit HARQ-ACK feedback to each TRP **105** for each PDCCH or PDSCH received.

[0104] In some cases, the UE **115** may determine a HARQ-ACK codebook for identifying timing-domain resource allocations for downlink transmissions (e.g., PDCCH or PDSCH) from a TRP **105** and for identifying when to transmit the HARQ-ACK feedback after receiving

the downlink transmissions. For example, a scheduling TRP **105** may transmit a downlink control information (DCI) message dynamically to the UE **115** that indicates information for enabling the UE **115** to dynamically construct a HARQ-ACK codebook for each downlink transmission received that necessitates a HARQ-ACK feedback message transmission. Additionally or alternatively, the UE **115** may determine the HARQ-ACK codebook semi-statically (e.g., RRC signaling) based on information from a TRP **105**, where the codebook does not change from transmission to transmission. In some cases, the HARQ-ACK codebook may be determined from a number of parameters, including a cell-specific uplink-downlink configuration, a table of time-domain resource allocations for PDSCH, a set of k_1 values (e.g., PDSCH-to-HARQ timelines), a number of cells (e.g., in a CA configuration), a PDSCH repetition factor, or a combination thereof. The k_1 values may indicate a number of TTIs (e.g., slots) between receiving a downlink channel message (e.g., PDSCH) and transmitting a corresponding HARQ-ACK message. Additionally, an example of the table of time-domain resource allocation for a PDSCH is given below in Table 1. K_0 indicates a slot offset for the PDSCH, S indicates the starting symbol of the PDSCH, and L indicates the length of the PDSCH (e.g., in symbols).

TABLE 1

Default PDSCH Time Domain Resource Allocation for Normal Cyclic Prefix						
Row Index	DMRS-TypeA-Position	PDSCH mapping type	K_0	S	L	
1	2	Type A	0	2	12	
	3	Type A	0	3	11	
2	2	Type A	0	2	10	
	3	Type A	0	3	9	
3	2	Type A	0	2	8	
	3	Type A	0	3	7	
4	2	Type A	0	2	6	
	3	Type A	0	3	5	
5	2	Type A	0	2	4	
	3	Type A	0	3	4	
6	2	Type B	0	9	4	
	3	Type B	0	10	4	
7	2	Type B	0	4	4	
	3	Type B	0	6	4	
8	2, 3	Type B	0	5	7	
9	2, 3	Type B	0	5	2	
10	2, 3	Type B	0	9	2	
11	2, 3	Type B	0	12	2	
12	2, 3	Type A	0	1	13	
13	2, 3	Type A	0	1	6	
14	2, 3	Type A	0	2	4	
15	2, 3	Type B	0	4	7	
16	2, 3	Type B	0	8	4	

[0105] In some cases, based on the information in Table 1, the UE **115** may determine that two or more PDSCH time-domain resource allocations indicate that two or more corresponding PDSCHs have a same ending OFDM symbol. Accordingly, the UE **115** may not be expected to receive more than one PDSCH in a same slot for the two or more allocations. Additionally, the UE **115** may only determine the HARQ-ACK codebook when communicating with one TRP **105**. As such, when communicating with multiple TRPs **105**, the UE **115** may be expected to transmit a feedback message (e.g., HARQ-ACK feedback) to each TRP **105** but may be unable to determine a HARQ-ACK codebook for the multiple TRPs **105** or may be unable to transmit multiple

feedback messages at the same time. In some cases, the UE **115** may choose one TRP **105** to respond to (e.g., based on a priority or similar criterion) or may not respond to any of the TRPs **105**. However, refraining from transmitting one or more feedback messages may lead to inefficient communications and unnecessary retransmissions.

[0106] Wireless communications system **100** may support efficient techniques for allocating separate slots or time durations for corresponding transmissions to separate TRPs **105**. For example, a scheduling TRP **105** (e.g., a gNB, base station **105**, the network, etc.) may configure a UE **115** with a slot allocation for PUCCH feedback between different TRPs **105**, such that ACK feedback to different TRPs may not occur with a same slot. Additionally, each TRP **105** may have different parameters for determining a corresponding HARQ-ACK codebook (e.g., TRP-specific parameters), and the UE **115** may then determine the HARQ-ACK codebook semi-statically in each slot for each TRP **105**. TRP-specific uplink parameters may also be the same within each slot for each TRP **105**, where the TRP-specific uplink parameters include QCL information, power control parameters, TA parameters, or a combination thereof. For time-domain resource allocations that have a same ending OFDM symbol for corresponding PDSCHs, the UE **115** may not be expected to receive more than one PDSCH in a same slot from a same TRP **105** or provide HARQ-ACK feedback for more than one PDSCH in a same slot in a same HARQ-ACK feedback message.

[0107] FIG. 2 illustrates an example of a wireless communications system **200** that supports ACK codebook design for multiple TRPs in accordance with aspects of the present disclosure. In some examples, wireless communications system **200** may implement aspects of wireless communications system **100**. Wireless communications system **200** may include a TRP **105-a**, a TRP **105-b**, and a UE **115-a**, which may be examples of base stations **105** (or TRPs **105**) and UEs **115**, respectively, as described herein with reference to FIG. 1. As described herein, TRP **105-a** and TRP **105-b** may communicate with UE **115-a** at a same time or a different time based on a NCJT scheme as described above. Additionally, TRP **105-a** and TRP **105-b** may have a non-ideal backhaul link **134-a** between each other, leading to each TRP **105** sending separate PDCCHs and/or PDSCHs in separate downlink transmissions **205** (e.g., TRP **105-a** may send downlink transmission **205-a** and TRP **105-b** may send downlink transmission **205-b**). UE **115-a** may then be expected to transmit HARQ-ACK feedback to each TRP **105** on uplink transmissions **210** to indicate whether the corresponding downlink transmissions **205** were correctly received.

[0108] As described herein, to prevent transmitting multiple uplink messages (e.g., multiple uplink transmissions **210**) simultaneously, a slot allocation may be configured where ACK/NACK feedback for different TRPs **105** at the slot level may be semi-statically TDMed. For example, TRP **105-a** (e.g., a master TRP **105**, a scheduling TRP **105**, the network, etc.) may configure UE **115-a** with a slot allocation for PUCCH feedback between the different TRPs **105**. In some cases, the slot allocation may be asymmetric. For example, a first slot may be allocated to TRP **105-a**, a second slot may be allocated to TRP **105-a**, a third slot may then be allocated to TRP **105-b**, a fourth slot may be allocated back to TRP **105-a**, a fifth slot may be allocated to TRP **105-a** as well, a fifth slot may then be allocated for TRP **105-b**, etc.

Additionally or alternatively, the slots may be allocated in an alternating pattern between the two TRPs **105**. For example, even slots may be allocated for TRP **105-a**, and odd slots may be allocated for TRP **105-b**.

[0109] Based on the slot allocation, ACK/NACK feedback to different TRPs **105** may not occur in a same slot, and network scheduling may guarantee that ACK/NACK feedback is confined to one TRP **105** per slot. For example, TRP **105-a** and TRP **105-b** (e.g., or any two TRPs **105**) may semi-statically coordinate over non-ideal backhaul link **134-a** for the HARQ-ACK feedback (e.g., ACK/NACK feedback). Additionally, there may be no restriction on PDSCH scheduling between the TRPs **105** and UE **115-a**. For example, UE **115-a** may receive multiple PDSCHs from both TRP **105-a** and TRP **105-b** within a same slot. In some cases, the slot allocation may be used for PUSCH and other uplink control information (UCI) (e.g., scheduling requests (SRs), channel state information (CSI) reports, etc.) rather than only HARQ-ACK transmissions. Accordingly, UE **115-a** may piggyback UCI (e.g., the HARQ-ACK, SRs, CSI reports, etc.) on the PUSCHs.

[0110] With the slot allocation, both dynamic and semi-static HARQ-ACK codebooks may be supported at UE **115-a**. For example, UE **115-a** may determine a HARQ-ACK codebook **215** for a TRP **105** in each slot. Based on the uplink slot allocation between TRPs, UE **115-a** may use TRP-specific parameters to determine a semi-static HARQ-ACK codebook for each TRP **105** for a given slot. The TRP-specific parameters may differ for each TRP **105**. For example, TRP **105-a** may have a different number of cells (e.g., in CA), a different cell-specific uplink-downlink configuration (e.g., per cell), a different table of time-domain resource allocations for PDSCH (e.g., per bandwidth part (BWP)), a different set of k1 values (e.g., PDSCH-to-HARQ timing per BWP), a different PDSCH repetition factor, or a combination thereof than TRP **105-b**. Accordingly, UE **115-a** may have a different set of TRP-specific parameters for each TRP **105** based on signaling from each TRP **105** that indicates one or more of the described parameters. In addition to indicating the number of cells that a TRP **105** supports, the TRP **105** may also indicate the cell identifications (IDs) that the TRP **105** supports. As such, UE **115-a** may generate a semi-static HARQ-ACK codebook for a given TRP **105** and may skip a particular cell if that cell is not supported by the given TRP **105**. For example, TRP **105-a** may operate over a first cell (e.g., with a first cell ID), and TRP **105-b** may operate over a second cell (e.g., with a second cell ID). Based on the indication of which cells they operate over, UE **115-a** may report HARQ-ACK for PDSCHs received in cell A to TRP **105-a** (e.g., in a slot allocated for TRP **105-a**) and for PDSCHs received in cell B to TRP **105-b** (e.g., in a slot allocated for TRP **105-b**) based on respective HARQ-ACK codebooks generated for each TRP **105**.

[0111] After identifying and/or determining the TRP-specific parameters for each TRP **105**, UE **115-a** may also know which slot is allocated for which TRP **105** based on the configured slot allocation (e.g., signaled to UE **115-a** explicitly) and may then know which parameters to use for determining HARQ-ACK codebook **215** for subsequent uplink transmissions (e.g., HARQ-ACK feedback) in the slot. Accordingly, UE **115-a** may transmit the ACK/NACK feedback on a PUCCH and/or on a PUSCH (e.g., via piggybacking).

[0112] In some cases, the table of time-domain resource allocations for PDSCH may indicate that two or more PDSCHs may end on the same OFDM symbol. As such, for time-domain resource allocations that have a same ending OFDM symbol for corresponding PDSCHs, UE **115-a** may not be expected to receive more than one PDSCH in a same slot from a same TRP **105** or to provide HARQ-ACK feedback for more than one PDSCH in a same slot in a same HARQ-ACK feedback message. Additionally or alternatively, UE **115-a** may receive two PDSCHs with a same ending OFDM symbol from two different TRPs **105**. For example, TRP **105-a** may transmit a first PDSCH, and TRP **105-b** may transmit a second PDSCH, where both PDSCHs end on the same OFDM symbol. Accordingly, UE **115-a** may be expected to receive each PDSCH from the respective TRP **105** even though they end on the same OFDM symbol.

[0113] Additionally or alternatively, UE **115-a** may not be expected to receive more than one PDSCH in a same slot on overlapping time-domain resource allocations. For example, if two or more PDSCHs (e.g., PDSCH occasions) overlap in time (e.g., regardless of whether the PDSCHs end on a same OFDM symbol or not), UE **115-a** may feedback one (1) HARQ-ACK for a given TRP **105**. As such, UE **115-a** may transmit HARQ-ACK feedback for a first PDSCH received in a slot, but not for any subsequent PDSCHs received in the same slot that overlap in the time-domain with the first PDSCH. Additionally, in some cases, UE **115-a** may determine to transmit the single HARQ-ACK feedback for the first PDSCH based on the overlapping PDSCHs being received from a same TRP **105**.

[0114] Additionally, one or more TRP-specific uplink parameters may differ per slot or TRP **105**. For example, QCL information for PUCCH may be configured per PUCCH resource (within a slot). The QCL information may determine the spatial-domain parameters for the PUCCH transmission. To support semi-static TDM of PUCCHs for multiple TRPs **105**, UE **115-a** may need to apply different QCL parameters (e.g., QCL information) to different slots (e.g., depending on slot allocation among TRPs **105**). For example, in a slot *n*, if slot *n* is an uplink slot allocated for TRP **105-a**, then UE **115-a** may follow a corresponding QCL condition for the PUCCH transmission. This QCL consideration may be used for frequency range **2** (FR2) (e.g., range for mmW communications). If the QCL information is not configured for PUCCH (e.g., in frequency range **1** (FR1)), UE **115-a** may use the same QCL parameters for PUCCH transmissions to different TRPs **105** (e.g., TRP **105-b**). Additionally, other TRP-specific uplink parameters may be applied to the different slots per TRP **105**. For example, different power control parameters may be applied to the different slots (e.g., depending on the slot allocation among TRPs **105**) and/or different TAs may be assumed in the different slots. In some cases, the one or more TRP-specific uplink parameters may be signaled to UE **115-a** through both DCI and semi-static (e.g., RRC signaling) messaging.

[0115] FIG. 3 illustrates an example of a slot allocation **300** that supports HARQ ACK codebook design for multiple TRPs in accordance with aspects of the present disclosure. In some examples, slot allocation **300** may implement aspects of wireless communications systems **100** and/or **200**. As described herein, slot allocation **300** may be configured for a UE **115** to receive one or more downlink messages

from multiple TRPs **105** and then transmit uplink messages to each TRP **105** within a separate slot allocated for the corresponding TRP **105**.

[0116] An occasion **305-a** for a first TRP A (e.g., a first TRP **105**) may be configured for the UE **115**, and an occasion **305-b** for a second TRP B (e.g., a second TRP **105**) may be configured for the UE **115**. Each occasion **305** may occupy a different BWP or a different set of RBs of a total bandwidth, such that the two occasions **305** occupy separate frequencies. Additionally or alternatively, occasions **305** from different TRPs may occupy the same time and frequency resources and may be separated in the spatial domain using different spatial layers (e.g., if the UE **115** supports MIMO reception). As such, the UE **115** may receive multiple PDSCHs **310** from both TRP A and TRP B within a same slot on different resources (e.g., based on the different BWPs, RBs, spatial layers, etc.). For example, the UE **115** may receive a first PDSCH **310-a** from TRP A and a second PDSCH **310-b** from TRP B within a slot *n*. Additionally, the UE **115** may receive a third PDSCH **310-c** from TRP A and a fourth PDSCH **310-d** from TRP B within a slot *n+1*. In some cases, the UE **115** may be expected to transmit HARQ-ACK feedback for each PDSCH **310** to the corresponding TRP. However, if the UE **115** were to transmit multiple PUCCHs **315** to each TRP within a same slot, collisions may occur that compromise either one or both PUCCHs **315**. In some cases, the UE **115** may be unable to determine separate HARQ-ACK codebooks for the separate TRPs (e.g., based on separate TRP-specific parameters for determining a HARQ-ACK codebook) within a same slot. Additionally or alternatively, the UE **115** may be unable to determine separate HARQ-ACK codebooks for the separate TRPs based on the separate TRPs having different TRP-specific uplink parameters. Accordingly, the UE **115** may be unable or may refrain from transmitting PUCCHs **315** to more than one TRP at a time.

[0117] A scheduling TRP or base station **105** may configure the UE **115** with a slot allocation for PUCCH **315** feedback between the different TRPs. For example, slot *n+2* may be allocated for a first PUCCH **315-a** that is transmitted to TRP A for HARQ-ACK feedback for first PDSCH **310-a** and third PDSCH **310-c**. Additionally, slot *n+3* may be allocated for a second PUCCH **315-b** that is transmitted to TRP B for HARQ-ACK feedback for second PDSCH **310-b** and fourth PDSCH **310-d**. The scheduling TRP or base station **105** may explicitly indicate which slot is allocated for which TRP to the UE **115**. In some cases, each TRP may indicate the slot for transmitting the HARQ-ACK feedback for a corresponding PDSCH **310** via DCI that contains the scheduling grant of that corresponding PDSCH **310**. For example, the TRP may transmit a DCI with a corresponding *k1* value to indicate which slot a corresponding PUCCH **315** is to be transmitted in for the PDSCH **310**. As shown in the example of slot allocation **300**, the *k1* value indicated in the DCI of first PDSCH **310-a** may be two (2) slots, and the *k1* value indicated in the DCI of third PDSCH **310-c** may be one (1) slot, indicating that first PUCCH **315-a** is to be transmitted two (2) slots after receiving first PDSCH **310-a** and one (1) slot after receiving third PDSCH **310-c**, respectively. Additionally or alternatively, the *k1* value indicated in the DCI of second PDSCH **310-b** may be three (3) slots, and the *k1* value indicated in the DCI of fourth PDSCH **310-d** may be two (2) slots, indicating that second PUCCH **315-b**

is to be transmitted three (3) slots after receiving second PDSCH **310-b** and two (2) slots after receiving fourth PDSCH **310-d**, respectively.

[0118] As described herein, the UE **115** may determine a separate HARQ-ACK codebook for each uplink slot (e.g., slot *n+2* and slot *n+3*). Each TRP may have different TRP-specific parameters, leading the UE **115** to determine separate HARQ-ACK codebooks for each uplink slot corresponding to the allocated TRP. In some cases, the HARQ-ACK feedback may be transmitted by piggybacking the HARQ-ACK feedback onto a PUSCH rather than transmitting in a PUCCH **315**. Additionally, each PUCCH **315** may have same TRP-specific uplink parameters (e.g., QCL information, power control parameters, TA parameters, etc.) as described above with reference to FIG. 2. Accordingly, each uplink slot may have a same HARQ-ACK codebook and same TRP-specific uplink parameters for messages (e.g., ACK/NACK feedback for each PDSCH **310**) transmitted in each PUCCH **315**.

[0119] FIG. 4 illustrates an example of a downlink channel schedule **400** that supports ACK codebook design for multiple TRPs in accordance with aspects of the present disclosure. In some examples, downlink channel schedule **400** may implement aspects of wireless communications systems **100** and/or **200**. Downlink channel schedule **400** may illustrate one or more PDSCHs **405** that are received at a UE **115** from one or more TRPs **105** (e.g., base stations **105**) within multiple slots **410**.

[0120] As shown, the UE **115** may receive a first PDSCH **405-a** in a first slot **410-a**. In some cases, first PDSCH **405-a** may be the only downlink transmission that the UE **115** receives in slot **410-a**. As such, the UE **115** may be able to decode first PDSCH **405-a** successfully without any interference from additional downlink messages. Alternatively, the UE **115** may receive a second PDSCH **405-b**, a third PDSCH **405-c**, and a fourth PDSCH **405-d** in a second slot **410-b**. The UE **115** may determine the ending points of each PDSCH **405** based on a table of time-domain resource allocations for PDSCHs as described above (e.g., Table 1 in FIG. 1). Accordingly, the UE **115** may determine that second PDSCH **405-b** ends at a symbol that does not coincide with any other PDSCHs **405** and, as such, may receive and decode the information in second PDSCH **405-b**.

[0121] Alternatively, the UE **115** may determine that third PDSCH **405-c** and fourth PDSCH **405-d** may both have a same ending OFDM symbol **415**. In some cases, third PDSCH **405-c** and fourth PDSCH **405-d** cannot be received from the same TRP. As such, the UE **115** may not be expected to receive more than one PDSCH **405** in a same slot **410** from the same TRP with the same ending OFDM symbol. Additionally, the UE **115** may not be expected to provide HARQ-ACK feedback for more than one PDSCH **405** with the same ending OFDM symbol in a same slot in a same HARQ-ACK feedback message. For example, the UE **115** may receive one of third PDSCH **405-c** and fourth PDSCH **405-d** from one TRP and then may transmit HARQ-ACK feedback for the chosen PDSCH **405** within a corresponding uplink slot allocated for the TRP. However, in some cases, the UE **115** may receive third PDSCH **405-c** from a first TRP and may receive fourth PDSCH **405-d** from a second TRP. Accordingly, the UE **115** may transmit the HARQ-ACK feedback for third PDSCH **405-c** in a first slot that corresponds to the first TRP (e.g., based on the slot allocation per TRP as described herein) and may transmit the

HARQ-ACK feedback for fourth PDSCH **405-d** in a different slot that corresponds to the second TRP (e.g., different than the first slot corresponding to the first TRP).

[0122] Additionally or alternatively, if two or more PDSCHs **405** (e.g., PDSCH occasions) overlap in time (e.g., regardless of whether the PDSCHs **405** end on a same OFDM symbol or not), the UE **115** may feedback one (1) HARQ-ACK for a given TRP. That is, the UE **115** may not be expected to receive more than one PDSCH **405** in a same slot **410** on overlapping time-domain resource allocations. As such, the UE **115** may transmit HARQ-ACK feedback for second PDSCH **405-b** received in second slot **410-b**, but not for third PDSCH **405-c** and fourth PDSCH **405-d** based on both third PDSCH **405-c** and fourth PDSCH **405-d** overlapping in the time-domain with second PDSCH **405-b**. Additionally, in some cases, the UE **115** may determine to transmit the single HARQ-ACK feedback for second PDSCH **405-b** based on second PDSCH **405-b**, third PDSCH **405-c**, and fourth PDSCH **405-d** being received from a same TRP.

[0123] FIG. 5 illustrates an example of an uplink channel repetition configuration **500** that supports ACK codebook design for multiple TRPs in accordance with aspects of the present disclosure. In some examples, uplink channel repetition configuration **500** may implement aspects of wireless communications systems **100** and/or **200**. In some cases, when a UE **115** transmits HARQ-ACK feedback for a received PDSCH, the UE **115** may transmit the HARQ-ACK feedback in a PUCCH **505** (e.g., or a PUSCH). However, as described above, the UE **115** may transmit a PUCCH **505** over multiple slots **510** (e.g., slot aggregation, PUCCH repetition, etc.), and some of the slots **510** may be allocated for different TRPs. In some cases, the allocation of slots to different TRPs may be configured and signaled via higher layer signaling (e.g., RRC configured).

[0124] For example, as shown, the UE **115** may be scheduled to transmit a first PUCCH **505-a** in a first slot **510-a**, a second PUCCH **505-b** in a second slot **510-b**, a third PUCCH **505-c** in a third slot **510-c**, and a fourth PUCCH **505-d** in a fourth slot **510-d** (e.g., four (4) repetitions of the PUCCH/PUSCH in four (4) separate slots, such that $K=4$) to a first TRP (e.g., TRP A). However, the second slot **510-b** and the fourth slot **510-d** may be allocated to a second TRP (e.g., TRP B). Accordingly, the UE **115** may run into issues when determining which slots **510** to transmit the PUCCHs **505** (e.g., PUCCH repetitions) to TRP A based on the slots **510** being allocated to slots other than TRP A.

[0125] In some cases, as described herein, the UE **115** may transmit PUCCHs **505** for TRP A in slots **510** that are allocated to this TRP A and may skip the PUCCH **505** transmissions in the slots **510** that are allocated for other TRP(s). Additionally, the skipped PUCCH **505** transmissions may not be deferred to other slots **510**. For example, as shown, the UE **115** may transmit the first PUCCH **505-a** in the first slot **510-a** and the third PUCCH **505-c** in the third slot **510-c** (e.g., transmit two repetitions of the PUCCH **505**). Additionally or alternatively, the UE **115** may transmit K PUCCHs **505**, where K is the configured repetition factor (e.g., $K=4$ as described above in the example of FIG. 5). Accordingly, the UE **115** may defer the skipped PUCCH **505** transmissions in the second slot **510-b** and the fourth slot **510-d** to other slots **510** that are allocated to TRP A. For example, the UE **115** may use slots **510** allocated to TRP A (e.g., the first slot **510-a**, the third slot **510-c**, a fifth slot

510-e, and a seventh slot **510**) to transmit the four (4) repetitions of the PUCCH **505**.

[0126] Additionally or alternatively, the UE **115** may transmit the PUCCHs **505** in K consecutive slots, as long as the starting slot **510** (e.g., the first slot **510**) is allocated to the intended TRP (e.g., TRP A). Accordingly, the UE **115** may not expect to be dynamically scheduled any other uplink transmissions in the slots **510** that are not allocated to TRP A (e.g., the second slot **510-b** and the fourth slot **510-d** for TRP B in the example of FIG. 5) and may use these slots **510** for transmitting the PUCCHs **505** (e.g., PUCCH repetitions, PUSCHs, PUSCH repetitions, etc.). In some cases, any semi-statically configured uplink transmissions in the slots **510** allocated to other TRPs (e.g., the second slot **510-b** and the fourth slot **510-d** for TRP B in the example of FIG. 5) may be dropped (e.g., due to conflict with transmission/repetition of PUCCH **505** to TRP A). As such, the UE **115** may transmit the first PUCCH **505-a** in the first slot **510-a**, the second PUCCH **505-b** in the second slot **510-b**, the third PUCCH **505-c** in the third slot **510-c**, and the fourth PUCCH **505-d** in the fourth slot **510-d** to TRP A, even though the second slot **510-b** and the fourth slot **510-d** are (e.g., semi-statically) allocated to TRP B. Additionally or alternatively, the UE **115** may not expect that any of the scheduled slots **510** are allocated to other TRPs. For example, a base station **105** may indicate that the K consecutive slots are allocated to the same TRP (e.g., TRP A). As such, the UE **115** may consider the example shown in FIG. 5 is an error case since the second slot **510-b** and the fourth slot **510-d** are allocated to TRP B.

[0127] In some cases, the UE **115** may determine which configuration to use for transmitting the HARQ-ACK feedback (e.g., in the PUCCHs **505**, PUSCHs, PUCCH/PUSCH repetitions, etc.) in the slots **510** based on signaling from a base station **105** (e.g., a serving base station **105**). For example, the base station **105** may signal which slots to use for transmitting the HARQ-ACK feedback to a TRP (e.g., the base station **105**) via higher layer signaling (e.g., RRC signaling), DCI, or additional types of downlink signaling.

[0128] FIG. 6 illustrates an example of a process flow **600** that supports ACK codebook design for multiple TRPs in accordance with aspects of the present disclosure. In some examples, process flow **600** may implement aspects of wireless communications systems **100** and/or **200**. Process flow **600** may include a TRP **105-c** and a UE **115-b**, which may be examples of TRPs **105** (e.g., base stations **105**) and UEs **115**, respectively, as described herein with reference to FIGS. 1-5. As described herein, UE **115-b** may be configured to communicate with multiple TRPs **105** simultaneously or at different times (e.g., including TRP **105-c**).

[0129] In the following description of the process flow **600**, the operations between UE **115-b** and TRP **105-c** may be performed in different orders or at different times. Certain operations may also be left out of the process flow **600**, or other operations may be added to the process flow **600**. It is to be understood that while UE **115-b** and TRP **105-c** are shown performing a number of the operations of process flow **600**, any wireless device may perform the operations shown.

[0130] At **605**, UE **115-b** may receive a slot allocation to provide HARQ-ACK feedback to multiple TRPs **105**. In some cases, UE **115-b** may receive an allocation of slots to be used for providing HARQ-ACK feedback to different TRPs **105** of the multiple TRPs **105**, where each slot

identified in the slot allocation is allocated for feedback transmissions by UE 115-*b* to only one TRP 105 of the plurality of TRPs 105 (e.g., TRP 105-*c*). Additionally or alternatively, UE 115-*b* may receive an allocation of slots to be used for providing HARQ-ACK feedback to different TRPs 105 of the multiple TRPs 105, where the slots are allocated asymmetrically between the multiple TRPs 105. In some cases, UE 115-*b* may receive the slot allocation via RRC signaling.

[0131] Additionally, in some cases, TRP 105-*c* may identify the slot allocation of at least one slot to be used by UE 115-*b* to provide the HARQ-ACK feedback back to TRP 105-*c*. Accordingly, TRP 105-*c* may transmit the slot allocation to one or more other TRPs 105 in communication with UE 115-*b* to facilitate slot allocation coordination between TRP 105-*c* and the one or more other TRPs 105. Additionally, TRP 105-*c* may receive, from the one or more other TRPs 105, additional slot allocations identifying slots to be used by UE 115-*b* to provide HARQ-ACK feedback to the one or more other TRPs 105, where each slot identified in the slot allocation and the additional slot allocations is allocated for feedback transmissions by UE 115-*b* to only one TRP 105.

[0132] At 610, UE 115-*b* may receive a DCI message that includes an indication of a size of a HARQ-ACK codebook.

[0133] At 615, UE 115-*b* may determine a TRP-specific HARQ-ACK codebook for feedback transmissions to TRP 105-*c* of the multiple TRPs 105 based on the slot allocation. In some cases, UE 115-*b* may determine the TRP-specific HARQ-ACK codebook based on the DCI message received at 610. Additionally or alternatively, UE 115-*b* may determine the TRP-specific HARQ-ACK codebook based on at least one TRP-specific parameter that is semi-statically received. For example, the at least one TRP-specific parameter may include one or more of a number of cells supported by TRP 105-*c* for CA, a cell-specific uplink-downlink configuration associated with a cell of TRP 105-*c*, a per-BWP table of time-domain resource allocation for PDSCHs for TRP 105-*c*, a per-BWP set of parameters defining PDSCH-to-feedback timing for TRP 105-*c* (e.g., k_1 values), or a per-BWP PDSCH repetition factor for TRP 105-*c*.

[0134] In some cases, UE 115-*b* may determine the TRP-specific HARQ-ACK codebook based on comparing the slot allocation with a cell-specific uplink-downlink configuration associated with a cell of TRP 105-*c*, where the feedback is transmitted to TRP 105-*c* using the corresponding slot only if the corresponding slot is identified as an uplink or flexible slot by the cell-specific uplink-downlink configuration. Additionally or alternatively, UE 115-*b* may determine the TRP-specific HARQ-ACK codebook based on comparing the slot allocation with a cell-specific uplink-downlink configuration associated with a cell of TRP 105-*c*, where the feedback is transmitted to TRP 105-*c* using the corresponding slot only if symbols of the corresponding slot allocated for feedback transmission are also allocated for uplink or flexible transmissions by the cell-specific uplink-downlink configuration.

[0135] At 620, UE 115-*b* may determine one or more TRP-specific uplink parameters for feedback transmissions to TRP 105-*c*. For example, UE 115-*b* may identify that QCL information is configured for PUCCH transmissions and then may identify TRP-specific QCL information for TRP 105-*c* for the corresponding slot. Additionally or alternatively, UE 115-*b* may identify TRP-specific power control

parameters for transmissions to TRP 105-*c* for the corresponding slot. Additionally or alternatively, UE 115-*b* may identify TRP-specific TA parameters for transmissions to TRP 105-*c* for the corresponding slot.

[0136] At 625, UE 115-*b* may transmit feedback to TRP 105-*c* using a corresponding slot identified by the slot allocation and using the TRP-specific HARQ-ACK codebook and the one or more TRP-specific uplink parameters. In some cases, UE 115-*b* may transmit the feedback via at least one of a PUCCH or as piggybacked UCI via a PUSCH. Additionally, the feedback transmitted to TRP 105-*c* using the corresponding slot may include feedback information pertaining to only one PDSCH of multiple time-domain resource allocations having a same ending OFDM symbol.

[0137] In some cases, UE 115-*b* may identify only one PDSCH reception opportunity per slot per cell from TRP 105-*c* for time-domain resource allocations that overlap in time (e.g., may additionally have a same ending OFDM symbol). As such, UE 115-*b* may receive one PDSCH transmission from TRP 105-*c* associated with the identified PDSCH reception opportunity, where the feedback to be transmitted in the corresponding slot includes feedback information pertaining to the one PDSCH reception or the PDSCH transmission. Additionally or alternatively, UE 115-*b* may receive, from an additional TRP 105 of the multiple TRPs 105, an additional PDSCH, the additional PDSCH having time-domain resource allocation in a same CC that overlaps with the PDSCH received from TRP 105-*c*. Accordingly, UE 115-*b* may transmit the HARQ-ACK feedback to the additional TRP 105 in a slot allocated for the additional TRP 105.

[0138] Additionally, in some cases, UE 115-*b* may determine to transmit a set of HARQ-ACK feedback messages (e.g., multiple PUCCHs, PUSCHs, PUCCH repetitions, PUSCH repetitions, etc.) to the TRP of the set of TRPs. Subsequently, UE 115-*b* may identify a set of slots based on the slot allocation to transmit the set of HARQ-ACK feedback messages to the TRP and may transmit the set of HARQ-ACK feedback messages to the TRP in the identified set of slots. For example, the set of slots may include slots allocated only to the TRP of the set of TRPs, a number of consecutive slots allocated to any of the set of TRPs, a number of consecutive slots allocated to the TRP of the set of TRPs, or a combination thereof.

[0139] At 630, UE 115-*b* may transmit additional information to TRP 105-*c* using the corresponding slot identified by the slot allocation. In some cases, the additional information may be in the form of a PUSCH payload, an SR, or a CSI report. Additionally or alternatively, the feedback may be combined with the additional information on a single uplink channel.

[0140] FIG. 7 shows a block diagram 700 of a device 705 that supports ACK codebook design for multiple TRPs in accordance with aspects of the present disclosure. The device 705 may be an example of aspects of a UE 115 as described herein. The device 705 may include a receiver 710, a UE codebook manager 715, and a transmitter 720. The device 705 may also include a processor. Each of these components may be in communication with one another (e.g., via one or more buses).

[0141] The receiver 710 may receive information such as packets, user data, or control information associated with various information channels (e.g., control channels, data channels, and information related to ACK codebook design

for multiple TRPs, etc.). Information may be passed on to other components of the device 705. The receiver 710 may be an example of aspects of the transceiver 1020 described with reference to FIG. 10. The receiver 710 may utilize a single antenna or a set of antennas.

[0142] The UE codebook manager 715 may receive a slot allocation for the UE to provide HARQ-ACK feedback to a set of TRPs. In some cases, the UE codebook manager 715 may determine a TRP-specific HARQ-ACK codebook for feedback transmissions to a TRP of the set of TRPs based on the slot allocation. Additionally, the UE codebook manager 715 may determine one or more TRP-specific uplink parameters for feedback transmissions to the TRP. The UE codebook manager 715 may then transmit feedback to the TRP using a corresponding slot identified by the slot allocation and using the TRP-specific HARQ-ACK codebook and the one or more TRP-specific uplink parameters. The UE codebook manager 715 may be an example of aspects of the UE codebook manager 1010 described herein.

[0143] The UE codebook manager 715, or its sub-components, may be implemented in hardware, code (e.g., software or firmware) executed by a processor, or any combination thereof. If implemented in code executed by a processor, the functions of the UE codebook manager 715, or its sub-components may be executed by a general-purpose processor, a digital signal processor (DSP), an application-specific integrated circuit (ASIC), a field-programmable gate array (FPGA) or other programmable logic device (PLD), discrete gate or transistor logic, discrete hardware components, or any combination thereof designed to perform the functions described in the present disclosure.

[0144] The UE codebook manager 715, or its sub-components, may be physically located at various positions, including being distributed such that portions of functions are implemented at different physical locations by one or more physical components. In some examples, the UE codebook manager 715, or its sub-components, may be a separate and distinct component in accordance with various aspects of the present disclosure. In some examples, the UE codebook manager 715, or its sub-components, may be combined with one or more other hardware components, including but not limited to an input/output (I/O) component, a transceiver, a network server, another computing device, one or more other components described in the present disclosure, or a combination thereof in accordance with various aspects of the present disclosure.

[0145] The transmitter 720 may transmit signals generated by other components of the device 705. In some examples, the transmitter 720 may be collocated with a receiver 710 in a transceiver module. For example, the transmitter 720 may be an example of aspects of the transceiver 1020 described with reference to FIG. 10. The transmitter 720 may utilize a single antenna or a set of antennas.

[0146] In some examples, the UE codebook manager 715 may be implemented as an integrated circuit or chipset for a mobile device modem, and the receiver 710 and transmitter 720 may be implemented as analog components (e.g., amplifiers, filters, antennas) coupled with the mobile device modem to enable wireless transmission and reception over one or more bands.

[0147] The UE codebook manager 715 as described herein may be implemented to realize one or more potential advantages. One implementation may allow the device 705 to receive slot allocation for transmitting ACK feedback to a

base station. The ACK feedback may include a corresponding slot identified by the slot allocation and a TRP-specific HARQ ACK codebook. This feedback may increase reliability and reduce latency during feedback transmissions.

[0148] Based on techniques for implementing feedback for grant-free uplink transmissions as described herein, a processor of a UE 115 (e.g., controlling the receiver 710, the transmitter 720, or the transceiver 1020 as described with reference to FIG. 10) may increase reliability and decrease signaling overhead in the communication of feedback because the UE 115 may avoid going through unnecessary configuration processes during retransmissions.

[0149] FIG. 8 shows a block diagram 800 of a device 805 that supports ACK codebook design for multiple TRPs in accordance with aspects of the present disclosure. The device 805 may be an example of aspects of a device 705, or a UE 115 as described herein. The device 805 may include a receiver 810, a UE codebook manager 815, and a transmitter 840. The device 805 may also include a processor. Each of these components may be in communication with one another (e.g., via one or more buses).

[0150] The receiver 810 may receive information such as packets, user data, or control information associated with various information channels (e.g., control channels, data channels, and information related to ACK codebook design for multiple TRPs, etc.). Information may be passed on to other components of the device 805. The receiver 810 may be an example of aspects of the transceiver 1020 described with reference to FIG. 10. The receiver 810 may utilize a single antenna or a set of antennas.

[0151] The UE codebook manager 815 may be an example of aspects of the UE codebook manager 715 as described herein. The UE codebook manager 815 may include a slot allocation receiver 820, a HARQ-ACK codebook component 825, an uplink parameter component 830, and a feedback transmitter 835. The UE codebook manager 815 may be an example of aspects of the UE codebook manager 1010 described herein.

[0152] The slot allocation receiver 820 may receive a slot allocation for the UE to provide HARQ-ACK feedback to a set of TRPs.

[0153] The HARQ-ACK codebook component 825 may determine a TRP-specific HARQ-ACK codebook for feedback transmissions to a TRP of the set of TRPs based on the slot allocation.

[0154] The uplink parameter component 830 may determine one or more TRP-specific uplink parameters for feedback transmissions to the TRP.

[0155] The feedback transmitter 835 may transmit feedback to the TRP using a corresponding slot identified by the slot allocation and using the TRP-specific HARQ-ACK codebook and the one or more TRP-specific uplink parameters.

[0156] The transmitter 840 may transmit signals generated by other components of the device 805. In some examples, the transmitter 840 may be collocated with a receiver 810 in a transceiver module. For example, the transmitter 840 may be an example of aspects of the transceiver 1020 described with reference to FIG. 10. The transmitter 840 may utilize a single antenna or a set of antennas.

[0157] In some examples, the UE codebook manager 815 may be implemented as an integrated circuit or chipset for a mobile device modem, and the receiver 810 and transmitter 840 may be implemented as analog components (e.g.,

amplifiers, filters, antennas) coupled with the mobile device modem to enable wireless transmission and reception over one or more bands.

[0158] The UE codebook manager 815 as described herein may be implemented to realize one or more potential advantages. One implementation may allow the device 805 to receive slot allocation for transmitting ACK feedback to a base station. The ACK feedback may include a corresponding slot identified by the slot allocation and a TRP-specific HARQ ACK codebook. This feedback may increase reliability and reduce latency during feedback transmissions.

[0159] Based on techniques for implementing feedback for grant-free uplink transmissions as described herein, a processor of a UE 115 (e.g., controlling the receiver 710, the transmitter 840, or the transceiver 1020 as described with reference to FIG. 10) may increase reliability and decrease signaling overhead in the communication of feedback because the UE 115 may avoid going through unnecessary configuration processes during retransmissions.

[0160] FIG. 9 shows a block diagram 900 of a UE codebook manager 905 that supports ACK codebook design for multiple TRPs in accordance with aspects of the present disclosure. The UE codebook manager 905 may be an example of aspects of a UE codebook manager 715, a UE codebook manager 815, or a UE codebook manager 1010 described herein. The UE codebook manager 905 may include a slot allocation receiver 910, a HARQ-ACK codebook component 915, an uplink parameter component 920, a feedback transmitter 925, a DCI component 930, a semi-static HARQ-ACK codebook component 935, and an uplink information component 940. Each of these modules may communicate, directly or indirectly, with one another (e.g., via one or more buses).

[0161] The slot allocation receiver 910 may receive a slot allocation for the UE to provide HARQ-ACK feedback to a set of TRPs. In some examples, the slot allocation receiver 910 may receive an allocation of slots to be used by the UE for providing HARQ-ACK feedback to different TRPs of the set of TRPs, where each slot identified in the slot allocation is allocated for feedback transmissions by the UE to only one TRP of the set of TRPs. Additionally or alternatively, the slot allocation receiver 910 may receive an allocation of slots to be used by the UE for providing HARQ-ACK feedback to different TRPs of the set of TRPs, where the slots are allocated asymmetrically between the set of TRPs. In some examples, the slot allocation receiver 910 may receive the slot allocation via RRC signaling.

[0162] The HARQ-ACK codebook component 915 may determine a TRP-specific HARQ-ACK codebook for feedback transmissions to a TRP of the set of TRPs based on the slot allocation. In some examples, the HARQ-ACK codebook component 915 may compare the slot allocation with a cell-specific uplink-downlink configuration associated with a cell of the TRP, where the feedback is transmitted to the TRP using the corresponding slot only if the corresponding slot is identified as an uplink slot by the cell-specific uplink-downlink configuration. Additionally or alternatively, the HARQ-ACK codebook component 915 may compare the slot allocation with a cell-specific uplink-downlink configuration associated with a cell of the TRP, where the feedback is transmitted to the TRP using the corresponding slot only if symbols of the corresponding slot

allocated for feedback transmission are also allocated for uplink transmissions by the cell-specific uplink-downlink configuration.

[0163] The uplink parameter component 920 may determine one or more TRP-specific uplink parameters for feedback transmissions to the TRP. In some examples, the uplink parameter component 920 may identify that QCL information is configured for PUCCH transmissions and may identify TRP-specific QCL information for the TRP for the corresponding slot. Additionally or alternatively, the uplink parameter component 920 may identify TRP-specific power control parameters for transmissions to the TRP for the corresponding slot. In some cases, the TRP-specific power control parameters may include at least one of an open-loop power control parameter and a closed-loop power control parameter. Additionally or alternatively, the uplink parameter component 920 may identify TRP-specific TA parameters for transmissions to the TRP for the corresponding slot.

[0164] The feedback transmitter 925 may transmit feedback to the TRP using a corresponding slot identified by the slot allocation and using the TRP-specific HARQ-ACK codebook and the one or more TRP-specific uplink parameters. In some examples, the feedback transmitter 925 may transmit the feedback via at least one of a PUCCH or as piggybacked UCI via a PUSCH. Additionally or alternatively, the feedback transmitted to the TRP using the corresponding slot may include feedback information pertaining to only one PDSCH of multiple time-domain resource allocations having a same ending OFDM symbol.

[0165] In some cases, the feedback transmitter 925 may determine to transmit a set of HARQ-ACK feedback messages to the TRP of the set of TRPs. Subsequently, the feedback transmitter 925 may identify a set of slots based on the slot allocation to transmit the set of HARQ-ACK feedback messages to the TRP and may transmit the set of HARQ-ACK feedback messages to the TRP in the identified set of slots. Additionally, the set of slots may include slots allocated only to the TRP of the set of TRPs, a number of consecutive slots allocated to any of the set of TRPs, a number of consecutive slots allocated to the TRP of the set of TRPs, or a combination thereof.

[0166] The DCI component 930 may receive a DCI message that includes an indication of a size of the HARQ-ACK codebook.

[0167] The semi-static HARQ-ACK codebook component 935 may determine the TRP-specific HARQ-ACK codebook based on at least one TRP-specific parameter that is semi-statically received. In some cases, the at least one TRP-specific parameter may include one or more of a number of cells supported by the TRP for CA, a cell-specific uplink-downlink configuration associated with a cell of the TRP, a per-BWP table of time-domain resource allocation for PDSCHs for the TRP, a per-BWP set of parameters defining PDSCH to feedback timing for the TRP, or a per-BWP PDSCH repetition factor for the TRP.

[0168] In some examples, the semi-static HARQ-ACK codebook component 935 may identify only one PDSCH reception opportunity per slot per cell from the TRP for time-domain resource allocations that have a same ending OFDM symbol. Accordingly, the semi-static HARQ-ACK codebook component 935 may receive one PDSCH transmission from the TRP associated with the identified PDSCH reception opportunity, where the feedback to be transmitted

in the corresponding slot includes feedback information pertaining to the one PDSCH reception or the PDSCH transmission.

[0169] Additionally or alternatively, the semi-static HARQ-ACK codebook component 935 may receive, from an additional TRP of the set of TRPs, an additional PDSCH, the additional PDSCH having a same ending OFDM symbol in a same CC as the PDSCH received from the TRP. Accordingly, the semi-static HARQ-ACK codebook component 935 may transmit the HARQ-ACK feedback to the additional TRP in a slot allocated for the additional TRP.

[0170] The uplink information component 940 may transmit additional information to the TRP using the corresponding slot identified by the slot allocation. In some cases, the additional information may be in the form of a PUSCH payload, an SR, or a CSI report. Additionally, the feedback may be combined with the additional information on a single uplink channel.

[0171] FIG. 10 shows a diagram of a system 1000 including a device 1005 that supports ACK codebook design for multiple TRPs in accordance with aspects of the present disclosure. The device 1005 may be an example of or include the components of device 705, device 805, or a UE 115 as described herein. The device 1005 may include components for bi-directional voice and data communications including components for transmitting and receiving communications, including a UE codebook manager 1010, an I/O controller 1015, a transceiver 1020, an antenna 1025, memory 1030, and a processor 1040. These components may be in electronic communication via one or more buses (e.g., bus 1045).

[0172] The UE codebook manager 1010 may receive a slot allocation for the UE to provide HARQ-ACK feedback to a set of TRPs. In some cases, the UE codebook manager 1010 may determine a TRP-specific HARQ-ACK codebook for feedback transmissions to a TRP of the set of TRPs based on the slot allocation. Additionally, the UE codebook manager 1010 may determine one or more TRP-specific uplink parameters for feedback transmissions to the TRP. The UE codebook manager 1010 may then transmit feedback to the TRP using a corresponding slot identified by the slot allocation and using the TRP-specific HARQ-ACK codebook and the one or more TRP-specific uplink parameters.

[0173] The I/O controller 1015 may manage input and output signals for the device 1005. The I/O controller 1015 may also manage peripherals not integrated into the device 1005. In some cases, the I/O controller 1015 may represent a physical connection or port to an external peripheral. In some cases, the I/O controller 1015 may utilize an operating system such as iOS®, ANDROID®, MS-DOS®, MS-WINDOWS®, OS/2®, UNIX®, LINUX®, or another known operating system. In other cases, the I/O controller 1015 may represent or interact with a modem, a keyboard, a mouse, a touchscreen, or a similar device. In some cases, the I/O controller 1015 may be implemented as part of a processor. In some cases, a user may interact with the device 1005 via the I/O controller 1015 or via hardware components controlled by the I/O controller 1015.

[0174] The transceiver 1020 may communicate bi-directionally, via one or more antennas, wired, or wireless links as described herein. For example, the transceiver 1020 may represent a wireless transceiver and may communicate bi-directionally with another wireless transceiver. The transceiver 1020 may also include a modem to modulate the

packets and provide the modulated packets to the antennas for transmission, and to demodulate packets received from the antennas.

[0175] In some cases, the wireless device may include a single antenna 1025. However, in some cases the device may have more than one antenna 1025, which may be capable of concurrently transmitting or receiving multiple wireless transmissions.

[0176] The memory 1030 may include random-access memory (RAM) and read-only memory (ROM). The memory 1030 may store computer-readable, computer-executable code 1035 including instructions that, when executed, cause the processor to perform various functions described herein. In some cases, the memory 1030 may contain, among other things, a basic I/O system (BIOS) which may control basic hardware or software operation such as the interaction with peripheral components or devices.

[0177] The processor 1040 may include an intelligent hardware device, (e.g., a general-purpose processor, a DSP, a central processing unit (CPU), a microcontroller, an ASIC, an FPGA, a PLD, a discrete gate or transistor logic component, a discrete hardware component, or any combination thereof). In some cases, the processor 1040 may be configured to operate a memory array using a memory controller. In other cases, a memory controller may be integrated into the processor 1040. The processor 1040 may be configured to execute computer-readable instructions stored in a memory (e.g., the memory 1030) to cause the device 1005 to perform various functions (e.g., functions or tasks supporting ACK codebook design for multiple TRPs).

[0178] The code 1035 may include instructions to implement aspects of the present disclosure, including instructions to support wireless communications. The code 1035 may be stored in a non-transitory computer-readable medium such as system memory or other type of memory. In some cases, the code 1035 may not be directly executable by the processor 1040 but may cause a computer (e.g., when compiled and executed) to perform functions described herein.

[0179] FIG. 11 shows a block diagram 1100 of a device 1105 that supports ACK codebook design for multiple TRPs in accordance with aspects of the present disclosure. The device 1105 may be an example of aspects of a base station 105 as described herein. The device 1105 may include a receiver 1110, a TRP slot allocation manager 1115, and a transmitter 1120. The device 1105 may also include a processor. Each of these components may be in communication with one another (e.g., via one or more buses).

[0180] The receiver 1110 may receive information such as packets, user data, or control information associated with various information channels (e.g., control channels, data channels, and information related to ACK codebook design for multiple TRPs, etc.). Information may be passed on to other components of the device 1105. The receiver 1110 may be an example of aspects of the transceiver 1420 described with reference to FIG. 14. The receiver 1110 may utilize a single antenna or a set of antennas.

[0181] The TRP slot allocation manager 1115 may identify, at the TRP, a slot allocation of at least one slot to be used by a UE to provide HARQ-ACK feedback to the TRP. The TRP slot allocation manager 1115 may then transmit a downlink message to the UE. Additionally, the TRP slot allocation manager 1115 may transmit an indication that the UE is to provide HARQ-ACK feedback using the at least

one slot identified by the slot allocation. In some cases, the TRP slot allocation manager **1115** may then receive, from the UE and on the at least one slot identified by the slot allocation, HARQ-ACK feedback pertaining to the downlink message. The TRP slot allocation manager **1115** may be an example of aspects of the TRP slot allocation manager **1410** described herein.

[0182] The TRP slot allocation manager **1115**, or its sub-components, may be implemented in hardware, code (e.g., software or firmware) executed by a processor, or any combination thereof. If implemented in code executed by a processor, the functions of the TRP slot allocation manager **1115**, or its sub-components may be executed by a general-purpose processor, a DSP, an ASIC, an FPGA or other PLD, discrete gate or transistor logic, discrete hardware components, or any combination thereof designed to perform the functions described in the present disclosure.

[0183] The TRP slot allocation manager **1115**, or its sub-components, may be physically located at various positions, including being distributed such that portions of functions are implemented at different physical locations by one or more physical components. In some examples, the TRP slot allocation manager **1115**, or its sub-components, may be a separate and distinct component in accordance with various aspects of the present disclosure. In some examples, the TRP slot allocation manager **1115**, or its sub-components, may be combined with one or more other hardware components, including but not limited to an I/O component, a transceiver, a network server, another computing device, one or more other components described in the present disclosure, or a combination thereof in accordance with various aspects of the present disclosure.

[0184] The transmitter **1120** may transmit signals generated by other components of the device **1105**. In some examples, the transmitter **1120** may be collocated with a receiver **1110** in a transceiver module. For example, the transmitter **1120** may be an example of aspects of the transceiver **1420** described with reference to FIG. **14**. The transmitter **1120** may utilize a single antenna or a set of antennas.

[0185] FIG. **12** shows a block diagram **1200** of a device **1205** that supports ACK codebook design for multiple TRPs in accordance with aspects of the present disclosure. The device **1205** may be an example of aspects of a device **1105**, or a base station **105** as described herein. The device **1205** may include a receiver **1210**, a TRP slot allocation manager **1215**, and a transmitter **1245**. The device **1205** may also include a processor. Each of these components may be in communication with one another (e.g., via one or more buses).

[0186] The receiver **1210** may receive information such as packets, user data, or control information associated with various information channels (e.g., control channels, data channels, and information related to ACK codebook design for multiple TRPs, etc.). Information may be passed on to other components of the device **1205**. The receiver **1210** may be an example of aspects of the transceiver **1420** described with reference to FIG. **14**. The receiver **1210** may utilize a single antenna or a set of antennas.

[0187] The TRP slot allocation manager **1215** may be an example of aspects of the TRP slot allocation manager **1115** as described herein. The TRP slot allocation manager **1215** may include a TRP slot allocation component **1220**, a slot allocation transmitter **1225**, a downlink message transmitter

1230, a HARQ-ACK feedback indicator **1235**, and a feedback receiver **1240**. The TRP slot allocation manager **1215** may be an example of aspects of the TRP slot allocation manager **1410** described herein.

[0188] The TRP slot allocation component **1220** may identify, at the TRP, a slot allocation of at least one slot to be used by a UE to provide HARQ-ACK feedback to the TRP.

[0189] The slot allocation transmitter **1225** may transmit the slot allocation to one or more other TRPs in communication with the UE to facilitate slot allocation coordination between the TRP and the one or more other TRPs.

[0190] The downlink message transmitter **1230** may transmit a downlink message to the UE.

[0191] The HARQ-ACK feedback indicator **1235** may transmit an indication that the UE is to provide HARQ-ACK feedback using the at least one slot identified by the slot allocation.

[0192] The feedback receiver **1240** may receive, from the UE and on the at least one slot identified by the slot allocation, HARQ-ACK feedback pertaining to the downlink message.

[0193] The transmitter **1245** may transmit signals generated by other components of the device **1205**. In some examples, the transmitter **1245** may be collocated with a receiver **1210** in a transceiver module. For example, the transmitter **1245** may be an example of aspects of the transceiver **1420** described with reference to FIG. **14**. The transmitter **1245** may utilize a single antenna or a set of antennas.

[0194] FIG. **13** shows a block diagram **1300** of a TRP slot allocation manager **1305** that supports ACK codebook design for multiple TRPs in accordance with aspects of the present disclosure. The TRP slot allocation manager **1305** may be an example of aspects of a TRP slot allocation manager **1115**, a TRP slot allocation manager **1215**, or a TRP slot allocation manager **1410** described herein. The TRP slot allocation manager **1305** may include a TRP slot allocation component **1310**, a slot allocation transmitter **1315**, a downlink message transmitter **1320**, a HARQ-ACK feedback indicator **1325**, a feedback receiver **1330**, a DCI transmitter **1335**, a TRP-specific parameter component **1340**, an uplink information receiver **1345**, and an uplink parameter transmitter **1350**. Each of these modules may communicate, directly or indirectly, with one another (e.g., via one or more buses).

[0195] The TRP slot allocation component **1310** may identify, at the TRP, a slot allocation of at least one slot to be used by a UE to provide HARQ-ACK feedback to the TRP. In some examples, the TRP slot allocation component **1310** may receive, from the one or more other TRPs, additional slot allocations identifying slots to be used by the UE to provide HARQ-ACK feedback to the one or more other TRPs, where each slot identified in the slot allocation and the additional slot allocations is allocated for feedback transmissions by the UE to only one TRP. In some cases, the slots may be allocated asymmetrically between the TRP and the additional TRPs.

[0196] The slot allocation transmitter **1315** may transmit the slot allocation to one or more other TRPs in communication with the UE to facilitate slot allocation coordination between the TRP and the one or more other TRPs. In some examples, the slot allocation transmitter **1315** may transmit the slot allocation via RRC signaling.

[0197] The downlink message transmitter 1320 may transmit a downlink message to the UE. In some examples, the downlink message transmitter 1320 may transmit only one PDSCH with a time-domain resource allocation having a same ending OFDM symbol per slot from the TRP.

[0198] The HARQ-ACK feedback indicator 1325 may transmit an indication that the UE is to provide HARQ-ACK feedback using the at least one slot identified by the slot allocation.

[0199] The feedback receiver 1330 may receive, from the UE and on the at least one slot identified by the slot allocation, HARQ-ACK feedback pertaining to the downlink message. In some cases, the HARQ-ACK feedback received from the UE in the at least one slot may include feedback information pertaining to only one PDSCH of multiple time-domain resource allocations having a same ending OFDM symbol.

[0200] In some examples, the feedback receiver 330 may receive the HARQ-ACK feedback on the at least one slot identified by the slot allocation only if the at least one slot is identified as an uplink slot by a cell-specific uplink-downlink configuration associated with the TRP. Additionally or alternatively, the feedback receiver 1330 may receive the HARQ-ACK feedback on symbols of the at least one slot identified by the slot allocation only if the symbols of the at least one slot are allocated for uplink transmissions by a cell-specific uplink-downlink configuration associated with the TRP. In some cases, the feedback receiver 1330 may receive the HARQ-ACK feedback via at least one of a PUCCH or as piggybacked UCI via a PUSCH.

[0201] The DCI transmitter 1335 may transmit the indication via a DCI message. In some examples, the DCI transmitter 335 may transmit a DCI message that includes an indication of a size of a HARQ-ACK codebook to be used by the UE in providing feedback to the TRP.

[0202] The TRP-specific parameter component 1340 may transmit at least one semi-static TRP-specific parameter to the UE. In some cases, the at least one TRP-specific parameter may include one or more of a number of cells supported by the TRP for CA, a cell-specific uplink-downlink configuration associated with a cell of the TRP, a per-BWP table of time-domain resource allocation for PDSCHs for the TRP, a per-BWP set of parameters defining PDSCH to feedback timing for the TRP, or a per-BWP PDSCH repetition factor for the TRP.

[0203] The uplink information receiver 1345 may receive additional information from the UE using the at least one slot identified by the slot allocation. In some cases, the additional information may be in the form of a PUSCH payload, an SR, or a CSI report. Additionally the HARQ-ACK feedback is combined with the additional information on a single uplink channel.

[0204] The uplink parameter transmitter 1350 may transmit TRP-specific QCL information to the UE. Additionally or alternatively, the uplink parameter transmitter 1350 may transmit TRP-specific power control parameters to the UE for transmissions to the TRP during the at least one slot. Additionally or alternatively, the uplink parameter transmitter 1350 may transmit TRP-specific TA parameters to the UE for transmissions to the TRP during the at least one slot.

[0205] FIG. 14 shows a diagram of a system 1400 including a device 1405 that supports ACK codebook design for multiple TRPs in accordance with aspects of the present disclosure. The device 1405 may be an example of or

include the components of device 1105, device 1205, or a base station 105 as described herein. The device 1405 may include components for bi-directional voice and data communications including components for transmitting and receiving communications, including a TRP slot allocation manager 1410, a network communications manager 1415, a transceiver 1420, an antenna 1425, memory 1430, a processor 1440, and an inter-station communications manager 1445. These components may be in electronic communication via one or more buses (e.g., bus 1450).

[0206] The TRP slot allocation manager 1410 may identify, at the TRP, a slot allocation of at least one slot to be used by a UE to provide HARQ-ACK feedback to the TRP. The TRP slot allocation manager 1410 may then transmit a downlink message to the UE. Additionally, the TRP slot allocation manager 1410 may transmit an indication that the UE is to provide HARQ-ACK feedback using the at least one slot identified by the slot allocation. In some cases, The TRP slot allocation manager 1410 may receive, from the UE and on the at least one slot identified by the slot allocation, HARQ-ACK feedback pertaining to the downlink message.

[0207] The network communications manager 1415 may manage communications with the core network (e.g., via one or more wired backhaul links). For example, the network communications manager 1415 may manage the transfer of data communications for client devices, such as one or more UEs 115.

[0208] The transceiver 1420 may communicate bi-directionally, via one or more antennas, wired, or wireless links as described herein. For example, the transceiver 1420 may represent a wireless transceiver and may communicate bi-directionally with another wireless transceiver. The transceiver 1420 may also include a modem to modulate the packets and provide the modulated packets to the antennas for transmission, and to demodulate packets received from the antennas.

[0209] In some cases, the wireless device may include a single antenna 1425. However, in some cases the device may have more than one antenna 1425, which may be capable of concurrently transmitting or receiving multiple wireless transmissions.

[0210] The memory 1430 may include RAM, ROM, or a combination thereof. The memory 1430 may store computer-readable code 1435 including instructions that, when executed by a processor (e.g., the processor 1440) cause the device to perform various functions described herein. In some cases, the memory 1430 may contain, among other things, a BIOS which may control basic hardware or software operation such as the interaction with peripheral components or devices.

[0211] The processor 1440 may include an intelligent hardware device, (e.g., a general-purpose processor, a DSP, a CPU, a microcontroller, an ASIC, an FPGA, a PLD, a discrete gate or transistor logic component, a discrete hardware component, or any combination thereof). In some cases, the processor 1440 may be configured to operate a memory array using a memory controller. In some cases, a memory controller may be integrated into processor 1440. The processor 1440 may be configured to execute computer-readable instructions stored in a memory (e.g., the memory 1430) to cause the device 1405 to perform various functions (e.g., functions or tasks supporting ACK codebook design for multiple TRPs).

[0212] The inter-station communications manager 1445 may manage communications with other base station 105 and may include a controller or scheduler for controlling communications with UEs 115 in cooperation with other base stations 105. For example, the inter-station communications manager 1445 may coordinate scheduling for transmissions to UEs 115 for various interference mitigation techniques such as beamforming or joint transmission. In some examples, the inter-station communications manager 1445 may provide an X2 interface within an LTE/LTE-A wireless communication network technology to provide communication between base stations 105.

[0213] The code 1435 may include instructions to implement aspects of the present disclosure, including instructions to support wireless communications. The code 1435 may be stored in a non-transitory computer-readable medium such as system memory or other type of memory. In some cases, the code 1435 may not be directly executable by the processor 1440 but may cause a computer (e.g., when compiled and executed) to perform functions described herein.

[0214] FIG. 15 shows a flowchart illustrating a method 1500 that supports ACK codebook design for multiple TRPs in accordance with aspects of the present disclosure. The operations of method 1500 may be implemented by a UE 115 or its components as described herein. For example, the operations of method 1500 may be performed by a UE codebook manager as described with reference to FIGS. 7 through 10. In some examples, a UE may execute a set of instructions to control the functional elements of the UE to perform the functions described herein. Additionally or alternatively, a UE may perform aspects of the functions described herein using special-purpose hardware.

[0215] At 1505, the UE may receive a slot allocation for the UE to provide HARQ-ACK feedback to a set of TRPs. The operations of 1505 may be performed according to the methods described herein. In some examples, aspects of the operations of 1505 may be performed by a slot allocation receiver as described with reference to FIGS. 7 through 10.

[0216] At 1510, the UE may determine a TRP-specific HARQ-ACK codebook for feedback transmissions to a TRP of the set of TRPs based on the slot allocation. The operations of 1510 may be performed according to the methods described herein. In some examples, aspects of the operations of 1510 may be performed by a HARQ-ACK codebook component as described with reference to FIGS. 7 through 10.

[0217] At 1515, the UE may determine one or more TRP-specific uplink parameters for feedback transmissions to the TRP. The operations of 1515 may be performed according to the methods described herein. In some examples, aspects of the operations of 1515 may be performed by an uplink parameter component as described with reference to FIGS. 7 through 10.

[0218] At 1520, the UE may transmit feedback to the TRP using a corresponding slot identified by the slot allocation and using the TRP-specific HARQ-ACK codebook and the one or more TRP-specific uplink parameters. The operations of 1520 may be performed according to the methods described herein. In some examples, aspects of the operations of 1520 may be performed by a feedback transmitter as described with reference to FIGS. 7 through 10.

[0219] FIG. 16 shows a flowchart illustrating a method 1600 that supports ACK codebook design for multiple TRPs in accordance with aspects of the present disclosure. The

operations of method 1600 may be implemented by a UE 115 or its components as described herein. For example, the operations of method 1600 may be performed by a UE codebook manager as described with reference to FIGS. 7 through 10. In some examples, a UE may execute a set of instructions to control the functional elements of the UE to perform the functions described herein. Additionally or alternatively, a UE may perform aspects of the functions described herein using special-purpose hardware.

[0220] At 1605, the UE may receive a slot allocation for the UE to provide HARQ-ACK feedback to a set of TRPs. The operations of 1605 may be performed according to the methods described herein. In some examples, aspects of the operations of 1605 may be performed by a slot allocation receiver as described with reference to FIGS. 7 through 10.

[0221] At 1610, the UE may receive an allocation of slots to be used by the UE for providing HARQ-ACK feedback to different TRPs of the set of TRPs, where each slot identified in the slot allocation is allocated for feedback transmissions by the UE to only one TRP of the set of TRPs. The operations of 1610 may be performed according to the methods described herein. In some examples, aspects of the operations of 1610 may be performed by a slot allocation receiver as described with reference to FIGS. 7 through 10.

[0222] At 1615, the UE may determine a TRP-specific HARQ-ACK codebook for feedback transmissions to a TRP of the set of TRPs based on the slot allocation. The operations of 1615 may be performed according to the methods described herein. In some examples, aspects of the operations of 1615 may be performed by a HARQ-ACK codebook component as described with reference to FIGS. 7 through 10.

[0223] At 1620, the UE may determine one or more TRP-specific uplink parameters for feedback transmissions to the TRP. The operations of 1620 may be performed according to the methods described herein. In some examples, aspects of the operations of 1620 may be performed by an uplink parameter component as described with reference to FIGS. 7 through 10.

[0224] At 1625, the UE may transmit feedback to the TRP using a corresponding slot identified by the slot allocation and using the TRP-specific HARQ-ACK codebook and the one or more TRP-specific uplink parameters. The operations of 1625 may be performed according to the methods described herein. In some examples, aspects of the operations of 1625 may be performed by a feedback transmitter as described with reference to FIGS. 7 through 10.

[0225] FIG. 17 shows a flowchart illustrating a method 1700 that supports ACK codebook design for multiple TRPs in accordance with aspects of the present disclosure. The operations of method 1700 may be implemented by a UE 115 or its components as described herein. For example, the operations of method 1700 may be performed by a UE codebook manager as described with reference to FIGS. 7 through 10. In some examples, a UE may execute a set of instructions to control the functional elements of the UE to perform the functions described herein. Additionally or alternatively, a UE may perform aspects of the functions described herein using special-purpose hardware.

[0226] At 1705, the UE may receive a slot allocation for the UE to provide HARQ-ACK feedback to a set of TRPs. The operations of 1705 may be performed according to the methods described herein. In some examples, aspects of the

operations of **1705** may be performed by a slot allocation receiver as described with reference to FIGS. 7 through 10.

[0227] At **1710**, the UE may receive a DCI message that includes an indication of a size of the HARQ-ACK codebook. The operations of **1710** may be performed according to the methods described herein. In some examples, aspects of the operations of **1710** may be performed by a DCI component as described with reference to FIGS. 7 through 10.

[0228] At **1715**, the UE may determine a TRP-specific HARQ-ACK codebook for feedback transmissions to a TRP of the set of TRPs based on the slot allocation. The operations of **1715** may be performed according to the methods described herein. In some examples, aspects of the operations of **1715** may be performed by a HARQ-ACK codebook component as described with reference to FIGS. 7 through 10.

[0229] At **1720**, the UE may determine one or more TRP-specific uplink parameters for feedback transmissions to the TRP. The operations of **1720** may be performed according to the methods described herein. In some examples, aspects of the operations of **1720** may be performed by an uplink parameter component as described with reference to FIGS. 7 through 10.

[0230] At **1725**, the UE may transmit feedback to the TRP using a corresponding slot identified by the slot allocation and using the TRP-specific HARQ-ACK codebook and the one or more TRP-specific uplink parameters. The operations of **1725** may be performed according to the methods described herein. In some examples, aspects of the operations of **1725** may be performed by a feedback transmitter as described with reference to FIGS. 7 through 10.

[0231] FIG. 18 shows a flowchart illustrating a method **1800** that supports ACK codebook design for multiple TRPs in accordance with aspects of the present disclosure. The operations of method **1800** may be implemented by a UE **115** or its components as described herein. For example, the operations of method **1800** may be performed by a UE codebook manager as described with reference to FIGS. 7 through 10. In some examples, a UE may execute a set of instructions to control the functional elements of the UE to perform the functions described herein. Additionally or alternatively, a UE may perform aspects of the functions described herein using special-purpose hardware.

[0232] At **1805**, the UE may receive a slot allocation for the UE to provide HARQ-ACK feedback to a set of TRPs. The operations of **1805** may be performed according to the methods described herein. In some examples, aspects of the operations of **1805** may be performed by a slot allocation receiver as described with reference to FIGS. 7 through 10.

[0233] At **1810**, the UE may determine the TRP-specific HARQ-ACK codebook based on at least one TRP-specific parameter that is semi-statically received. The operations of **1810** may be performed according to the methods described herein. In some examples, aspects of the operations of **1810** may be performed by a semi-static HARQ-ACK codebook component as described with reference to FIGS. 7 through 10.

[0234] At **1815**, the UE may determine a TRP-specific HARQ-ACK codebook for feedback transmissions to a TRP of the set of TRPs based on the slot allocation. The operations of **1815** may be performed according to the methods described herein. In some examples, aspects of the opera-

tions of **1815** may be performed by a HARQ-ACK codebook component as described with reference to FIGS. 7 through 10.

[0235] At **1820**, the UE may determine one or more TRP-specific uplink parameters for feedback transmissions to the TRP. The operations of **1820** may be performed according to the methods described herein. In some examples, aspects of the operations of **1820** may be performed by an uplink parameter component as described with reference to FIGS. 7 through 10.

[0236] At **1825**, the UE may transmit feedback to the TRP using a corresponding slot identified by the slot allocation and using the TRP-specific HARQ-ACK codebook and the one or more TRP-specific uplink parameters. The operations of **1825** may be performed according to the methods described herein. In some examples, aspects of the operations of **1825** may be performed by a feedback transmitter as described with reference to FIGS. 7 through 10.

[0237] FIG. 19 shows a flowchart illustrating a method **1900** that supports ACK codebook design for multiple TRPs in accordance with aspects of the present disclosure. The operations of method **1900** may be implemented by a base station **105** or its components as described herein. For example, the operations of method **1900** may be performed by a TRP slot allocation manager as described with reference to FIGS. 11 through 14. In some examples, a base station may execute a set of instructions to control the functional elements of the base station to perform the functions described herein. Additionally or alternatively, a base station may perform aspects of the functions described herein using special-purpose hardware.

[0238] At **1905**, the base station may identify, at the TRP, a slot allocation of at least one slot to be used by a UE to provide HARQ-ACK feedback to the TRP. The operations of **1905** may be performed according to the methods described herein. In some examples, aspects of the operations of **1905** may be performed by a TRP slot allocation component as described with reference to FIGS. 11 through 14.

[0239] At **1910**, the base station may transmit the slot allocation to one or more other TRPs in communication with the UE to facilitate slot allocation coordination between the TRP and the one or more other TRPs. The operations of **1910** may be performed according to the methods described herein. In some examples, aspects of the operations of **1910** may be performed by a slot allocation transmitter as described with reference to FIGS. 11 through 14.

[0240] At **1915**, the base station may transmit a downlink message to the UE. The operations of **1915** may be performed according to the methods described herein. In some examples, aspects of the operations of **1915** may be performed by a downlink message transmitter as described with reference to FIGS. 11 through 14.

[0241] At **1920**, the base station may transmit an indication that the UE is to provide HARQ-ACK feedback using the at least one slot identified by the slot allocation. The operations of **1920** may be performed according to the methods described herein. In some examples, aspects of the operations of **1920** may be performed by a HARQ-ACK feedback indicator as described with reference to FIGS. 11 through 14.

[0242] At **1925**, the base station may receive, from the UE and on the at least one slot identified by the slot allocation, HARQ-ACK feedback pertaining to the downlink message.

The operations of **1925** may be performed according to the methods described herein. In some examples, aspects of the operations of **1925** may be performed by a feedback receiver as described with reference to FIGS. **11** through **14**.

[0243] FIG. **20** shows a flowchart illustrating a method **2000** that supports ACK codebook design for multiple TRPs in accordance with aspects of the present disclosure. The operations of method **2000** may be implemented by a base station **105** or its components as described herein. For example, the operations of method **2000** may be performed by a TRP slot allocation manager as described with reference to FIGS. **11** through **14**. In some examples, a base station may execute a set of instructions to control the functional elements of the base station to perform the functions described herein. Additionally or alternatively, a base station may perform aspects of the functions described herein using special-purpose hardware.

[0244] At **2005**, the base station may identify, at the TRP, a slot allocation of at least one slot to be used by a UE to provide HARQ-ACK feedback to the TRP. The operations of **2005** may be performed according to the methods described herein. In some examples, aspects of the operations of **2005** may be performed by a TRP slot allocation component as described with reference to FIGS. **11** through **14**.

[0245] At **2010**, the base station may receive, from the one or more other TRPs, additional slot allocations identifying slots to be used by the UE to provide HARQ-ACK feedback to the one or more other TRPs, where each slot identified in the slot allocation and the additional slot allocations is allocated for feedback transmissions by the UE to only one TRP. The operations of **2010** may be performed according to the methods described herein. In some examples, aspects of the operations of **2010** may be performed by a TRP slot allocation component as described with reference to FIGS. **11** through **14**.

[0246] At **2015**, the base station may transmit the slot allocation to one or more other TRPs in communication with the UE to facilitate slot allocation coordination between the TRP and the one or more other TRPs. The operations of **2015** may be performed according to the methods described herein. In some examples, aspects of the operations of **2015** may be performed by a slot allocation transmitter as described with reference to FIGS. **11** through **14**.

[0247] At **2020**, the base station may transmit a downlink message to the UE. The operations of **2020** may be performed according to the methods described herein. In some examples, aspects of the operations of **2020** may be performed by a downlink message transmitter as described with reference to FIGS. **11** through **14**.

[0248] At **2025**, the base station may transmit an indication that the UE is to provide HARQ-ACK feedback using the at least one slot identified by the slot allocation. The operations of **2025** may be performed according to the methods described herein. In some examples, aspects of the operations of **2025** may be performed by a HARQ-ACK feedback indicator as described with reference to FIGS. **11** through **14**.

[0249] At **2030**, the base station may receive, from the UE and on the at least one slot identified by the slot allocation, HARQ-ACK feedback pertaining to the downlink message. The operations of **2030** may be performed according to the methods described herein. In some examples, aspects of the

operations of **2030** may be performed by a feedback receiver as described with reference to FIGS. **11** through **14**.

[0250] It should be noted that the methods described herein describe possible implementations, and that the operations and the steps may be rearranged or otherwise modified and that other implementations are possible. Further, aspects from two or more of the methods may be combined.

[0251] Techniques described herein may be used for various wireless communications systems such as code division multiple access (CDMA), time division multiple access (TDMA), frequency division multiple access (FDMA), orthogonal frequency division multiple access (OFDMA), single carrier frequency division multiple access (SC-FDMA), and other systems. A CDMA system may implement a radio technology such as CDMA2000, Universal Terrestrial Radio Access (UTRA), etc. CDMA2000 covers IS-2000, IS-95, and IS-856 standards. IS-2000 Releases may be commonly referred to as CDMA2000 1x, 1x, etc. IS-856 (TIA-856) is commonly referred to as CDMA2000 1xEV-DO, High Rate Packet Data (HRPD), etc. UTRA includes Wideband CDMA (WCDMA) and other variants of CDMA. A TDMA system may implement a radio technology such as Global System for Mobile Communications (GSM).

[0252] An OFDMA system may implement a radio technology such as Ultra Mobile Broadband (UMB), Evolved UTRA (E-UTRA), Institute of Electrical and Electronics Engineers (IEEE) 802.11 (Wi-Fi), IEEE 802.16 (WiMAX), IEEE 802.20, Flash-OFDM, etc. UTRA and E-UTRA are part of Universal Mobile Telecommunications System (UMTS). LTE, LTE-A, and LTE-A Pro are releases of UMTS that use E-UTRA. UTRA, E-UTRA, UMTS, LTE, LTE-A, LTE-A Pro, NR, and GSM are described in documents from the organization named "3rd Generation Partnership Project" (3GPP). CDMA2000 and UMB are described in documents from an organization named "3rd Generation Partnership Project 2" (3GPP2). The techniques described herein may be used for the systems and radio technologies mentioned herein as well as other systems and radio technologies. While aspects of an LTE, LTE-A, LTE-A Pro, or NR system may be described for purposes of example, and LTE, LTE-A, LTE-A Pro, or NR terminology may be used in much of the description, the techniques described herein are applicable beyond LTE, LTE-A, LTE-A Pro, or NR applications.

[0253] A macro cell generally covers a relatively large geographic area (e.g., several kilometers in radius) and may allow unrestricted access by UEs **115** with service subscriptions with the network provider. A small cell may be associated with a lower-powered base station **105**, as compared with a macro cell, and a small cell may operate in the same or different (e.g., licensed, unlicensed, etc.) frequency bands as macro cells. Small cells may include pico cells, femto cells, and micro cells according to various examples. A pico cell, for example, may cover a small geographic area and may allow unrestricted access by UEs **115** with service subscriptions with the network provider. A femto cell may also cover a small geographic area (e.g., a home) and may provide restricted access by UEs **115** having an association with the femto cell (e.g., UEs **115** in a closed subscriber group (CSG), UEs **115** for users in the home, and the like). An eNB for a macro cell may be referred to as a macro eNB. An eNB for a small cell may be referred to as a small cell eNB, a pico eNB, a femto eNB, or a home eNB. An eNB

may support one or multiple (e.g., two, three, four, and the like) cells, and may also support communications using one or multiple component carriers.

[0254] The wireless communications system **100** or systems described herein may support synchronous or asynchronous operation. For synchronous operation, the base stations **105** may have similar frame timing, and transmissions from different base stations **105** may be approximately aligned in time. For asynchronous operation, the base stations **105** may have different frame timing, and transmissions from different base stations **105** may not be aligned in time. The techniques described herein may be used for either synchronous or asynchronous operations.

[0255] Information and signals described herein may be represented using any of a variety of different technologies and techniques. For example, data, instructions, commands, information, signals, bits, symbols, and chips that may be referenced throughout the description may be represented by voltages, currents, electromagnetic waves, magnetic fields or particles, optical fields or particles, or any combination thereof.

[0256] The various illustrative blocks and modules described in connection with the disclosure herein may be implemented or performed with a general-purpose processor, a DSP, an ASIC, an FPGA or other PLD, discrete gate or transistor logic, discrete hardware components, or any combination thereof designed to perform the functions described herein. A general-purpose processor may be a microprocessor, but in the alternative, the processor may be any conventional processor, controller, microcontroller, or state machine. A processor may also be implemented as a combination of computing devices (e.g., a combination of a DSP and a microprocessor, multiple microprocessors, one or more microprocessors in conjunction with a DSP core, or any other such configuration).

[0257] The functions described herein may be implemented in hardware, software executed by a processor, firmware, or any combination thereof. If implemented in software executed by a processor, the functions may be stored on or transmitted over as one or more instructions or code on a computer-readable medium. Other examples and implementations are within the scope of the disclosure and appended claims. For example, due to the nature of software, functions described herein can be implemented using software executed by a processor, hardware, firmware, hardwiring, or combinations of any of these. Features implementing functions may also be physically located at various positions, including being distributed such that portions of functions are implemented at different physical locations.

[0258] Computer-readable media includes both non-transitory computer storage media and communication media including any medium that facilitates transfer of a computer program from one place to another. A non-transitory storage medium may be any available medium that can be accessed by a general purpose or special purpose computer. By way of example, and not limitation, non-transitory computer-readable media may include RAM, ROM, electrically erasable programmable read only memory (EEPROM), flash memory, compact disk (CD) ROM or other optical disk storage, magnetic disk storage or other magnetic storage devices, or any other non-transitory medium that can be used to carry or store desired program code means in the form of instructions or data structures and that can be accessed by a general-purpose or special-purpose computer, or a general-

purpose or special-purpose processor. Also, any connection is properly termed a computer-readable medium. For example, if the software is transmitted from a website, server, or other remote source using a coaxial cable, fiber optic cable, twisted pair, digital subscriber line (DSL), or wireless technologies such as infrared, radio, and microwave, then the coaxial cable, fiber optic cable, twisted pair, DSL, or wireless technologies such as infrared, radio, and microwave are included in the definition of medium. Disk and disc, as used herein, include CD, laser disc, optical disc, digital versatile disc (DVD), floppy disk and Blu-ray disc where disks usually reproduce data magnetically, while discs reproduce data optically with lasers. Combinations of the above are also included within the scope of computer-readable media.

[0259] As used herein, including in the claims, “or” as used in a list of items (e.g., a list of items prefaced by a phrase such as “at least one of” or “one or more of”) indicates an inclusive list such that, for example, a list of at least one of A, B, or C means A or B or C or AB or AC or BC or ABC (i.e., A and B and C). Also, as used herein, the phrase “based on” shall not be construed as a reference to a closed set of conditions. For example, an exemplary step that is described as “based on condition A” may be based on both a condition A and a condition B without departing from the scope of the present disclosure. In other words, as used herein, the phrase “based on” shall be construed in the same manner as the phrase “based at least in part on.”

[0260] In the appended figures, similar components or features may have the same reference label. Further, various components of the same type may be distinguished by following the reference label by a dash and a second label that distinguishes among the similar components. If just the first reference label is used in the specification, the description is applicable to any one of the similar components having the same first reference label irrespective of the second reference label, or other subsequent reference label.

[0261] The description set forth herein, in connection with the appended drawings, describes example configurations and does not represent all the examples that may be implemented or that are within the scope of the claims. The term “exemplary” used herein means “serving as an example, instance, or illustration,” and not “preferred” or “advantageous over other examples.” The detailed description includes specific details for the purpose of providing an understanding of the described techniques. These techniques, however, may be practiced without these specific details. In some instances, well-known structures and devices are shown in block diagram form in order to avoid obscuring the concepts of the described examples.

[0262] The description herein is provided to enable a person skilled in the art to make or use the disclosure. Various modifications to the disclosure will be readily apparent to those skilled in the art, and the generic principles defined herein may be applied to other variations without departing from the scope of the disclosure. Thus, the disclosure is not limited to the examples and designs described herein but is to be accorded the broadest scope consistent with the principles and novel features disclosed herein.

What is claimed is:

1. A method for wireless communication at a user equipment (UE), comprising:

receiving a slot allocation for the UE to provide hybrid automatic repeat request (HARQ) acknowledgement feedback to a plurality of transmission reception points (TRPs);

determining a TRP-specific HARQ acknowledgement codebook for feedback transmissions to a TRP of the plurality of TRPs based at least in part on the slot allocation;

determining one or more TRP-specific uplink parameters for feedback transmissions to the TRP; and

transmitting feedback to the TRP using a corresponding slot identified by the slot allocation and using the TRP-specific HARQ acknowledgement codebook and the one or more TRP-specific uplink parameters.

2. The method of claim 1, wherein receiving the slot allocation comprises:

receiving an allocation of slots to be used by the UE for providing HARQ acknowledgement feedback to different TRPs of the plurality of TRPs, wherein each slot identified in the slot allocation is allocated for feedback transmissions by the UE to only one TRP of the plurality of TRPs.

3. The method of claim 1, wherein receiving the slot allocation comprises:

receiving an allocation of slots to be used by the UE for providing HARQ acknowledgement feedback to different TRPs of the plurality of TRPs, wherein the slots are allocated asymmetrically between the plurality of TRPs.

4. The method of claim 1, wherein determining the TRP-specific HARQ acknowledgement codebook comprises:

determining the TRP-specific HARQ acknowledgement codebook based on at least one TRP-specific parameter that is semi-statically received.

5. The method of claim 4, wherein the at least one TRP-specific parameter is one or more of a number of cells supported by the TRP for carrier aggregation, a cell-specific uplink-downlink configuration associated with a cell of the TRP, a per-bandwidth part table of time-domain resource allocation for physical downlink shared channels for the TRP, a per-bandwidth part set of parameters defining physical downlink shared channel to feedback timing for the TRP, or a per-bandwidth part physical downlink shared channel repetition factor for the TRP.

6. The method of claim 1, further comprising:

identifying only one physical downlink shared channel reception opportunity per slot per cell from the TRP for time-domain resource allocations that overlap in time; and

receiving one physical downlink shared channel transmission from the TRP associated with the identified physical downlink shared channel reception opportunity, wherein the feedback to be transmitted in the corresponding slot includes feedback information pertaining to the one physical downlink shared channel reception opportunity or the physical downlink shared channel transmission.

7. The method of claim 6, further comprising:

receiving, from an additional TRP of the plurality of TRPs, an additional physical downlink shared channel,

the additional physical downlink shared channel having a time-domain resource allocation in a same component carrier that overlaps with the physical downlink shared channel transmission received from the TRP; and

transmitting the HARQ acknowledgement feedback to the additional TRP in a slot allocated for the additional TRP.

8. The method of claim 1, wherein determining the TRP-specific HARQ acknowledgement codebook comprises:

comparing the slot allocation with a cell-specific uplink-downlink configuration associated with a cell of the TRP, wherein the feedback is transmitted to the TRP using the corresponding slot only if symbols of the corresponding slot allocated for feedback transmission are also allocated for uplink transmissions by the cell-specific uplink-downlink configuration.

9. The method of claim 1, further comprising:

transmitting additional information to the TRP using the corresponding slot identified by the slot allocation.

10. The method of claim 9, wherein the additional information is in a form of a physical uplink shared channel payload, a scheduling request, or a channel state information report, and wherein the feedback is combined with the additional information on a single uplink channel.

11. The method of claim 1, wherein transmitting feedback to the TRP using the corresponding slot comprises:

transmitting the feedback via at least one of a physical uplink control channel or as piggybacked uplink control information via a physical uplink shared channel.

12. The method of claim 1, wherein determining the one or more TRP-specific uplink parameters for feedback transmissions to the TRP comprises:

identifying that quasi co-location (QCL) information is configured for physical uplink control channel transmissions; and

identifying TRP-specific QCL information for the TRP for the corresponding slot.

13. The method of claim 1, wherein determining the one or more TRP-specific uplink parameters for feedback transmissions to the TRP comprises:

identifying TRP-specific power control parameters for transmissions to the TRP for the corresponding slot.

14. The method of claim 13, wherein the TRP-specific power control parameters comprise at least one of an open-loop power control parameter and a closed-loop power control parameter.

15. The method of claim 1, wherein determining the one or more TRP-specific uplink parameters for feedback transmissions to the TRP comprises:

identifying TRP-specific timing advance parameters for transmissions to the TRP for the corresponding slot.

16. The method of claim 1, wherein receiving the slot allocation comprises:

receiving the slot allocation via radio resource control (RRC) signaling.

17. The method of claim 1, further comprising:

determining to transmit a plurality of HARQ acknowledgement feedback messages to the TRP of the plurality of TRPs;

identifying a plurality of slots based at least in part on the slot allocation to transmit the plurality of HARQ acknowledgement feedback messages to the TRP; and

transmitting the plurality of HARQ acknowledgement feedback messages to the TRP in the identified plurality of slots.

18. The method of claim **17**, wherein the plurality of slots comprises slots allocated only to the TRP of the plurality of TRPs, a number of consecutive slots allocated to any of the plurality of TRPs, a number of consecutive slots allocated to the TRP of the plurality of TRPs, or a combination thereof.

19. A method for wireless communication at a transmission reception point (TRP), comprising:

identifying, at the TRP, a slot allocation of at least one slot to be used by a user equipment (UE) to provide hybrid automatic repeat request (HARQ) acknowledgement feedback to the TRP;

transmitting a downlink message to the UE;

transmitting an indication that the UE is to provide HARQ acknowledgement feedback using the at least one slot identified by the slot allocation; and

receiving, from the UE and on the at least one slot identified by the slot allocation, the HARQ acknowledgement feedback pertaining to the downlink message.

20. The method of claim **19**, further comprising:

transmitting the slot allocation to one or more other TRPs in communication with the UE to facilitate slot allocation coordination between the TRP and the one or more other TRPs;

receiving, from the one or more other TRPs, additional slot allocations identifying slots to be used by the UE to provide HARQ acknowledgement feedback to the one or more other TRPs, wherein each slot identified in the slot allocation and the additional slot allocations is allocated for feedback transmissions by the UE to only one TRP;

or a combination thereof.

21. The method of claim **20**, wherein the slots are allocated asymmetrically between the TRP and the one or more other TRPs.

22. The method of claim **19**, wherein transmitting the indication comprises:

transmitting the indication via a downlink control information message.

23. The method of claim **19**, further comprising:

transmitting at least one semi-static TRP-specific parameter to the UE.

24. The method of claim **23**, wherein the at least one semi-static TRP-specific parameter is one or more of a number of cells supported by the TRP for carrier aggregation, a cell-specific uplink-downlink configuration associated with a cell of the TRP, a per-bandwidth part table of time-domain resource allocation for physical downlink shared channels for the TRP, a per-bandwidth part set of parameters defining physical downlink shared channel to feedback timing for the TRP, or a per-bandwidth part physical downlink shared channel repetition factor for the TRP.

25. The method of claim **19**, wherein receiving HARQ acknowledgement feedback pertaining to the downlink message comprises:

receiving the HARQ acknowledgement feedback on the at least one slot identified by the slot allocation only if the at least one slot is identified as an uplink slot by a cell-specific uplink-downlink configuration associated with the TRP.

26. The method of claim **19**, wherein receiving HARQ acknowledgement feedback pertaining to the downlink message comprises:

receiving the HARQ acknowledgement feedback on symbols of the at least one slot identified by the slot allocation only if the symbols of the at least one slot are allocated for uplink transmissions by a cell-specific uplink-downlink configuration associated with the TRP.

27. The method of claim **19**, further comprising:

receiving additional information from the UE using the at least one slot identified by the slot allocation.

28. The method of claim **27**, wherein the additional information is in a form of a physical uplink shared channel payload, a scheduling request, or a channel state information report, and wherein the HARQ acknowledgement feedback is combined with the additional information on a single uplink channel.

29. The method of claim **19**, wherein receiving HARQ acknowledgement feedback pertaining to the downlink message comprises:

receiving the HARQ acknowledgement feedback via at least one of a physical uplink control channel or as piggybacked uplink control information via a physical uplink shared channel.

30. The method of claim **19**, further comprising:

transmitting TRP-specific quasi co-location (QCL) information to the UE.

31. The method of claim **19**, further comprising:

transmitting TRP-specific power control parameters to the UE for transmissions to the TRP during the at least one slot.

32. The method of claim **19**, further comprising:

transmitting TRP-specific timing advance parameters to the UE for transmissions to the TRP during the at least one slot.

33. The method of claim **19**, further comprising:

transmitting the slot allocation via radio resource control (RRC) signaling.

34. An apparatus for wireless communication at a user equipment (UE), comprising:

a processor,

memory coupled with the processor; and

instructions stored in the memory and executable by the processor to cause the apparatus to:

receive a slot allocation for the UE to provide hybrid automatic repeat request (HARQ) acknowledgement feedback to a plurality of transmission reception points (TRPs);

determine a TRP-specific HARQ acknowledgement codebook for feedback transmissions to a TRP of the plurality of TRPs based at least in part on the slot allocation;

determine one or more TRP-specific uplink parameters for feedback transmissions to the TRP; and

transmit feedback to the TRP using a corresponding slot identified by the slot allocation and using the TRP-specific HARQ acknowledgement codebook and the one or more TRP-specific uplink parameters.

35. The apparatus of claim **34**, wherein the instructions to receive the slot allocation are executable by the processor to cause the apparatus to:

receive an allocation of slots to be used by the UE for providing HARQ acknowledgement feedback to dif-

ferent TRPs of the plurality of TRPs, wherein each slot identified in the slot allocation is allocated for feedback transmissions by the UE to only one TRP of the plurality of TRPs.

36. The apparatus of claim **34**, wherein the instructions to receive the slot allocation are executable by the processor to cause the apparatus to:

receive an allocation of slots to be used by the UE for providing HARQ acknowledgement feedback to different TRPs of the plurality of TRPs, wherein the slots are allocated asymmetrically between the plurality of TRPs.

37. The apparatus of claim **34**, wherein the instructions to determine the TRP-specific HARQ acknowledgement codebook are executable by the processor to cause the apparatus to:

determine the TRP-specific HARQ acknowledgement codebook based on at least one TRP-specific parameter that is semi-statically received.

38. The apparatus of claim **34**, wherein the instructions are further executable by the processor to cause the apparatus to:

identify only one physical downlink shared channel reception opportunity per slot per cell from the TRP for time-domain resource allocations that overlap in time; and

receive one physical downlink shared channel transmission from the TRP associated with the identified physical downlink shared channel reception opportunity, wherein the feedback to be transmitted in the corresponding slot includes feedback information pertaining to the one physical downlink shared channel reception opportunity or the physical downlink shared channel transmission.

39. The apparatus of claim **38**, wherein the instructions are further executable by the processor to cause the apparatus to:

receive, from an additional TRP of the plurality of TRPs, an additional physical downlink shared channel, the additional physical downlink shared channel having a time-domain resource allocation in a same component carrier that overlaps with the physical downlink shared channel transmission received from the TRP; and

transmit the HARQ acknowledgement feedback to the additional TRP in a slot allocated for the additional TRP.

40. The apparatus of claim **34**, wherein the instructions to transmit feedback to the TRP using the corresponding slot are executable by the processor to cause the apparatus to:

transmit the feedback via at least one of a physical uplink control channel or as piggybacked uplink control information via a physical uplink shared channel.

41. The apparatus of claim **34**, wherein the instructions to determine the one or more TRP-specific uplink parameters for feedback transmissions to the TRP are executable by the processor to cause the apparatus to:

identify TRP-specific power control parameters for transmissions to the TRP for the corresponding slot.

42. The apparatus of claim **34**, wherein the instructions are further executable by the processor to cause the apparatus to:

determining to transmit a plurality of HARQ acknowledgement feedback messages to the TRP of the plurality of TRPs;

identifying a plurality of slots based at least in part on the slot allocation to transmit the plurality of HARQ acknowledgement feedback messages to the TRP; and transmitting the plurality of HARQ acknowledgement feedback messages to the TRP in the identified plurality of slots.

43. An apparatus for wireless communication at a transmission reception point (TRP), comprising:

a processor;

memory coupled with the processor; and

instructions stored in the memory and executable by the processor to cause the apparatus to:

identify, at the TRP, a slot allocation of at least one slot to be used by a user equipment (UE) to provide hybrid automatic repeat request (HARQ) acknowledgement feedback to the TRP;

transmit a downlink message to the UE;

transmit an indication that the UE is to provide HARQ acknowledgement feedback using the at least one slot identified by the slot allocation; and

receive, from the UE and on the at least one slot identified by the slot allocation, HARQ acknowledgement feedback pertaining to the downlink message.

44. The apparatus of claim **43**, wherein the instructions are further executable by the processor to cause the apparatus to:

transmit the slot allocation to one or more other TRPs in communication with the UE to facilitate slot allocation coordination between the TRP and the one or more other TRPs;

receive, from the one or more other TRPs, additional slot allocations identifying slots to be used by the UE to provide HARQ acknowledgement feedback to the one or more other TRPs, wherein each slot identified in the slot allocation and the additional slot allocations is allocated for feedback transmissions by the UE to only one TRP;

or a combination thereof.

45. The apparatus of claim **44**, wherein the slots are allocated asymmetrically between the TRP and the one or more other TRPs.

46. The apparatus of claim **43**, wherein the instructions to transmit the indication are executable by the processor to cause the apparatus to:

transmit the indication via a downlink control information message.

47. An apparatus for wireless communication at a user equipment (UE), comprising:

means for receiving a slot allocation for the UE to provide hybrid automatic repeat request (HARQ) acknowledgement feedback to a plurality of transmission reception points (TRPs);

means for determining a TRP-specific HARQ acknowledgement codebook for feedback transmissions to a TRP of the plurality of TRPs based at least in part on the slot allocation;

means for determining one or more TRP-specific uplink parameters for feedback transmissions to the TRP; and

means for transmitting feedback to the TRP using a corresponding slot identified by the slot allocation and using the TRP-specific HARQ acknowledgement codebook and the one or more TRP-specific uplink parameters.

48. An apparatus for wireless communication at a transmission reception point (TRP), comprising:

means for identifying, at the TRP, a slot allocation of at least one slot to be used by a user equipment (UE) to provide hybrid automatic repeat request (HARQ) acknowledgement feedback to the TRP;

means for transmitting the slot allocation to one or more other TRPs in communication with the UE to facilitate slot allocation coordination between the TRP and the one or more other TRPs;

means for transmitting a downlink message to the UE;

means for transmitting an indication that the UE is to provide HARQ acknowledgement feedback using the at least one slot identified by the slot allocation; and
means for receiving, from the UE and on the at least one slot identified by the slot allocation, HARQ acknowledgement feedback pertaining to the downlink message.

49. A non-transitory computer-readable medium storing code for wireless communication at a user equipment (UE), the code comprising instructions executable by a processor to:

receive a slot allocation for the UE to provide hybrid automatic repeat request (HARQ) acknowledgement feedback to a plurality of transmission reception points (TRPs);

determine a TRP-specific HARQ acknowledgement codebook for feedback transmissions to a TRP of the plurality of TRPs based at least in part on the slot allocation;

determine one or more TRP-specific uplink parameters for feedback transmissions to the TRP; and

transmit feedback to the TRP using a corresponding slot identified by the slot allocation and using the TRP-specific HARQ acknowledgement codebook and the one or more TRP-specific uplink parameters.

50. A non-transitory computer-readable medium storing code for wireless communication at a transmission reception point (TRP), the code comprising instructions executable by a processor to:

identify, at the TRP, a slot allocation of at least one slot to be used by a user equipment (UE) to provide hybrid automatic repeat request (HARQ) acknowledgement feedback to the TRP;

transmit the slot allocation to one or more other TRPs in communication with the UE to facilitate slot allocation coordination between the TRP and the one or more other TRPs;

transmit a downlink message to the UE;

transmit an indication that the UE is to provide HARQ acknowledgement feedback using the at least one slot identified by the slot allocation; and

receive, from the UE and on the at least one slot identified by the slot allocation, HARQ acknowledgement feedback pertaining to the downlink message.

* * * * *