



US 20160101646A1

(19) **United States**

(12) **Patent Application Publication**
KICENIU K

(10) **Pub. No.: US 2016/0101646 A1**

(43) **Pub. Date: Apr. 14, 2016**

(54) **METHOD AND APPARATUS FOR THE APPLICATION AND STORAGE OF SURFACE COATING MATERIALS**

(52) **U.S. Cl.**
CPC *B44D 3/126* (2013.01); *B44D 3/121* (2013.01); *B44D 3/127* (2013.01); *B44D 3/14* (2013.01); *B65D 25/16* (2013.01); *A45F 5/00* (2013.01)

(71) Applicant: **TARAS KICENIU K, SANTA PAULA, CA (US)**

(72) Inventor: **TARAS KICENIU K, SANTA PAULA, CA (US)**

(21) Appl. No.: **14/511,176**

(22) Filed: **Oct. 10, 2014**

Publication Classification

(51) **Int. Cl.**
B44D 3/12 (2006.01)
B65D 25/16 (2006.01)
A45F 5/00 (2006.01)
B44D 3/14 (2006.01)

(57) **ABSTRACT**

A method and apparatus are described for the improved application, transportation, and storage of surface coating materials including: paints, stains, cleaners, and preservatives; the present method employs a carrying and storage container in conjunction with a sealing lid; with the lid in place liquid coating materials and wet tools can be stored for extended periods of time between coating application jobs without the need to empty the container or wash out the tools; both magnetic means and selective enclosure are taught by the present invention for effective wet tool storage, whereby eliminating washing up saves time and coating products, as well as conserving wash up supplies.

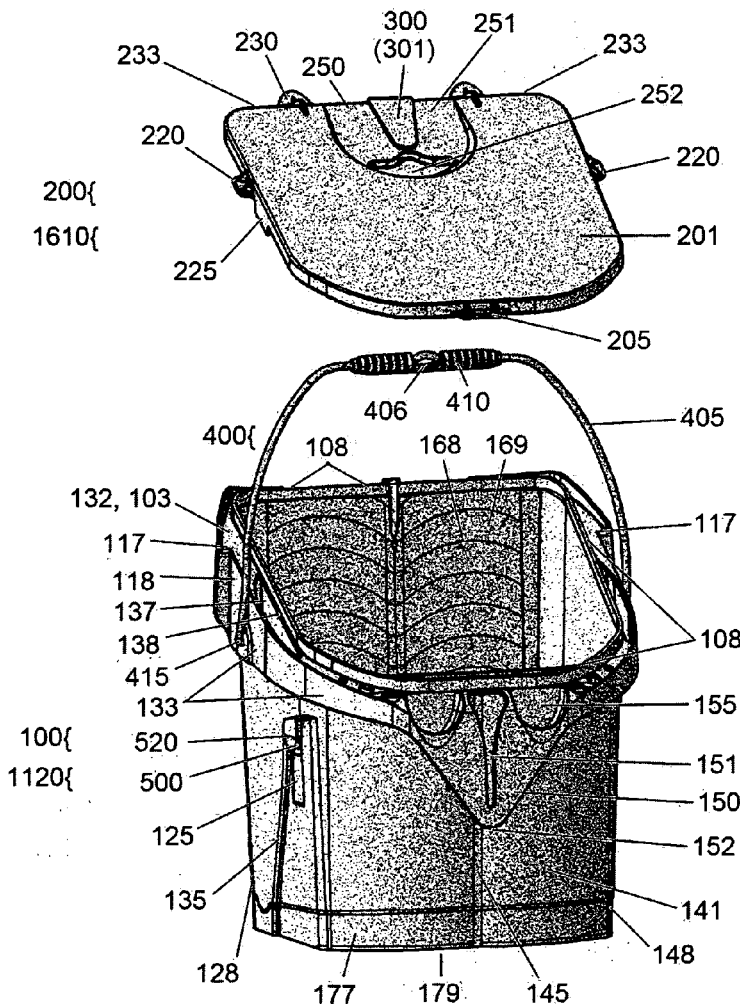

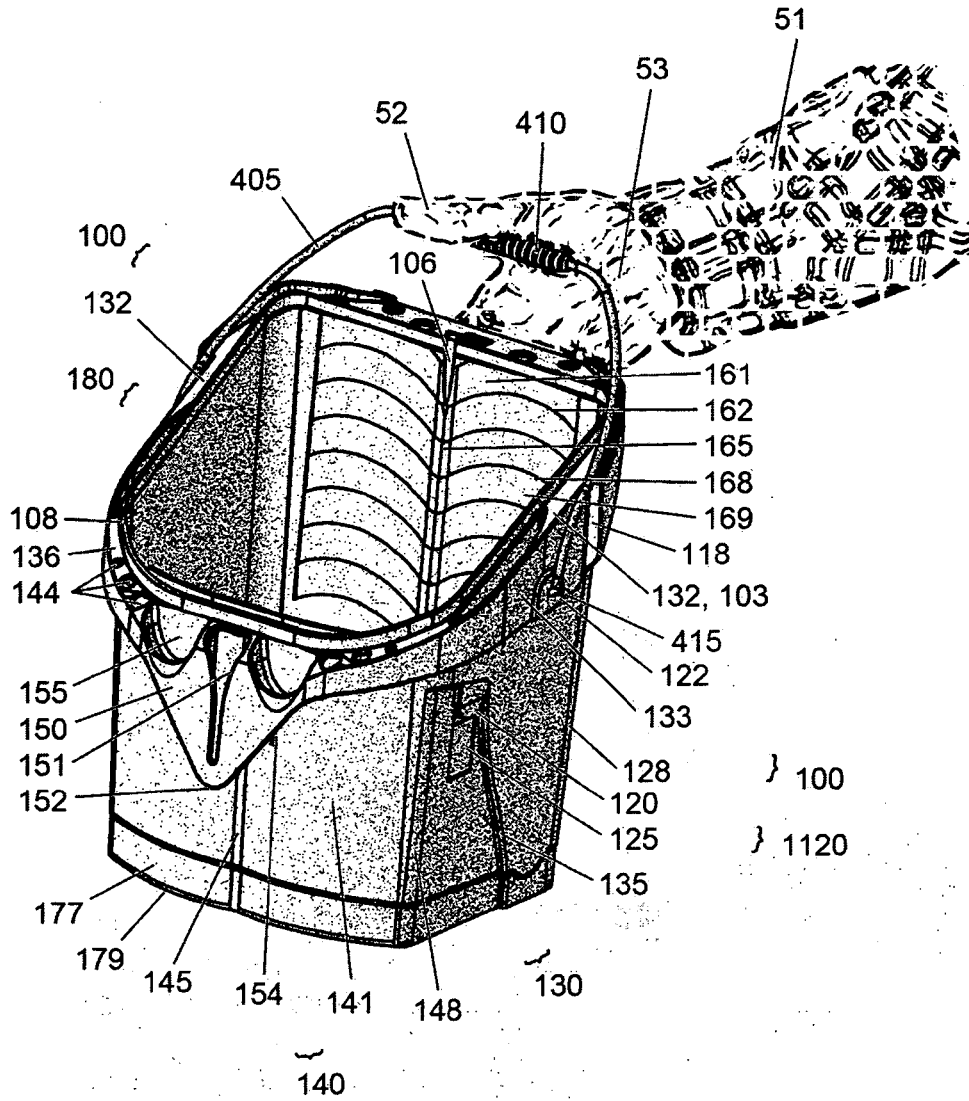

Fig. 1

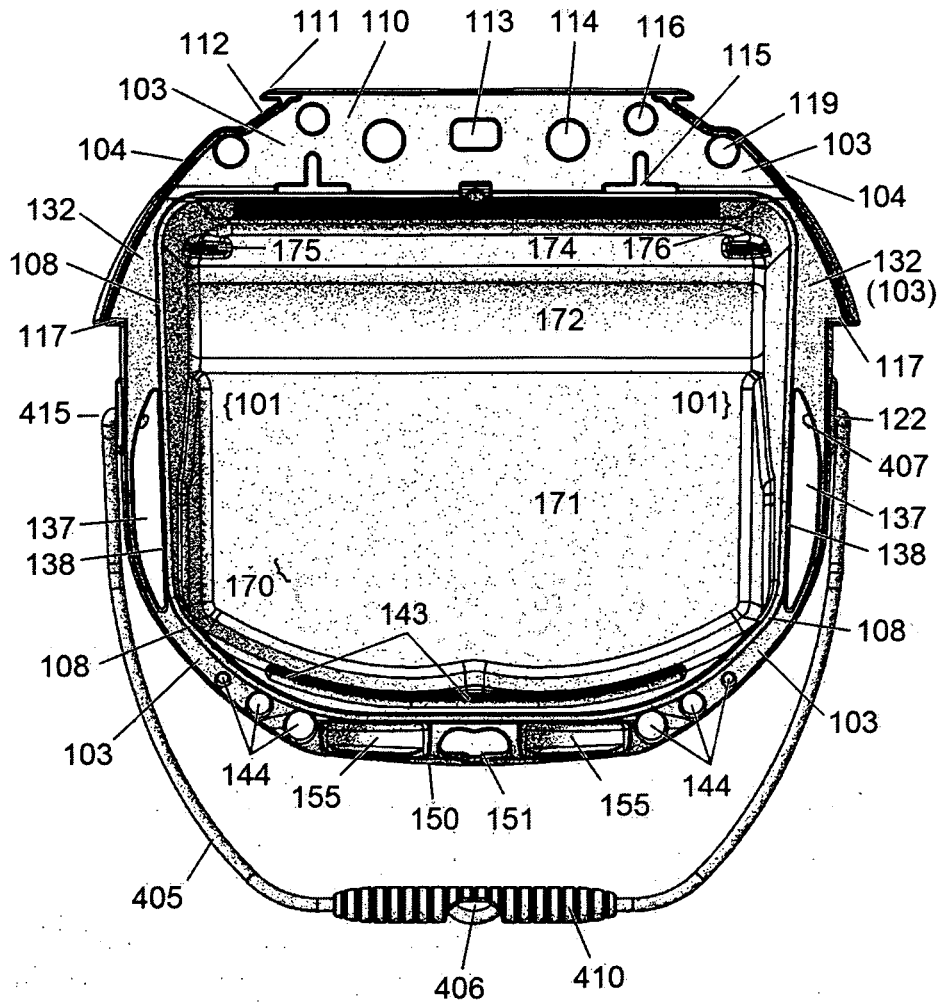

Fig. 3

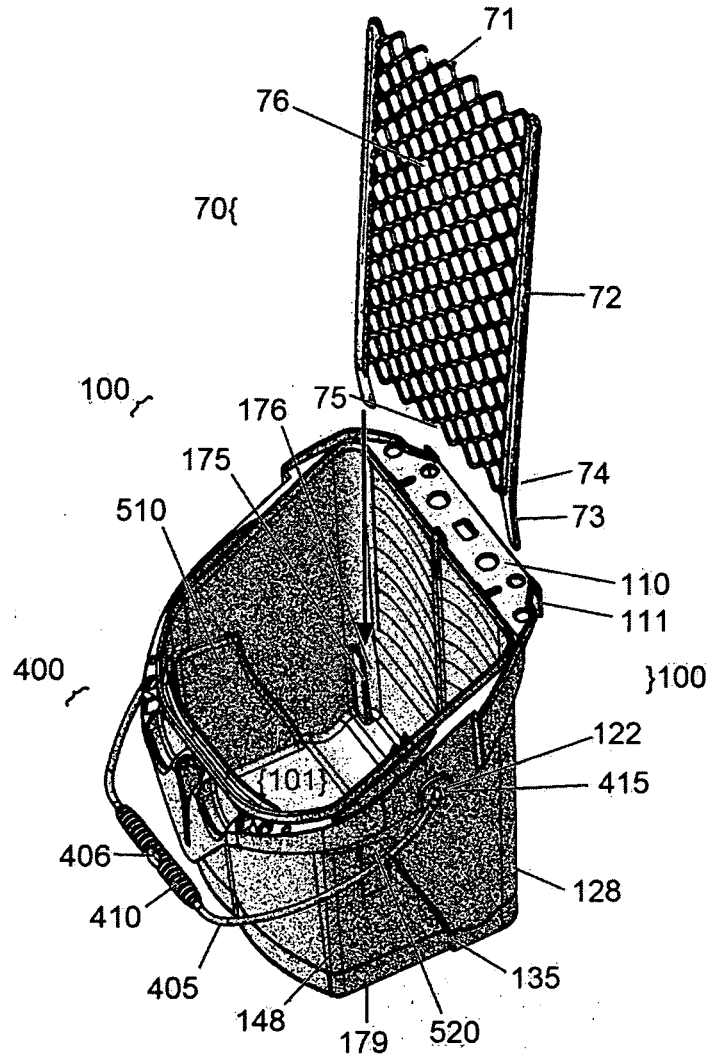

Fig. 4

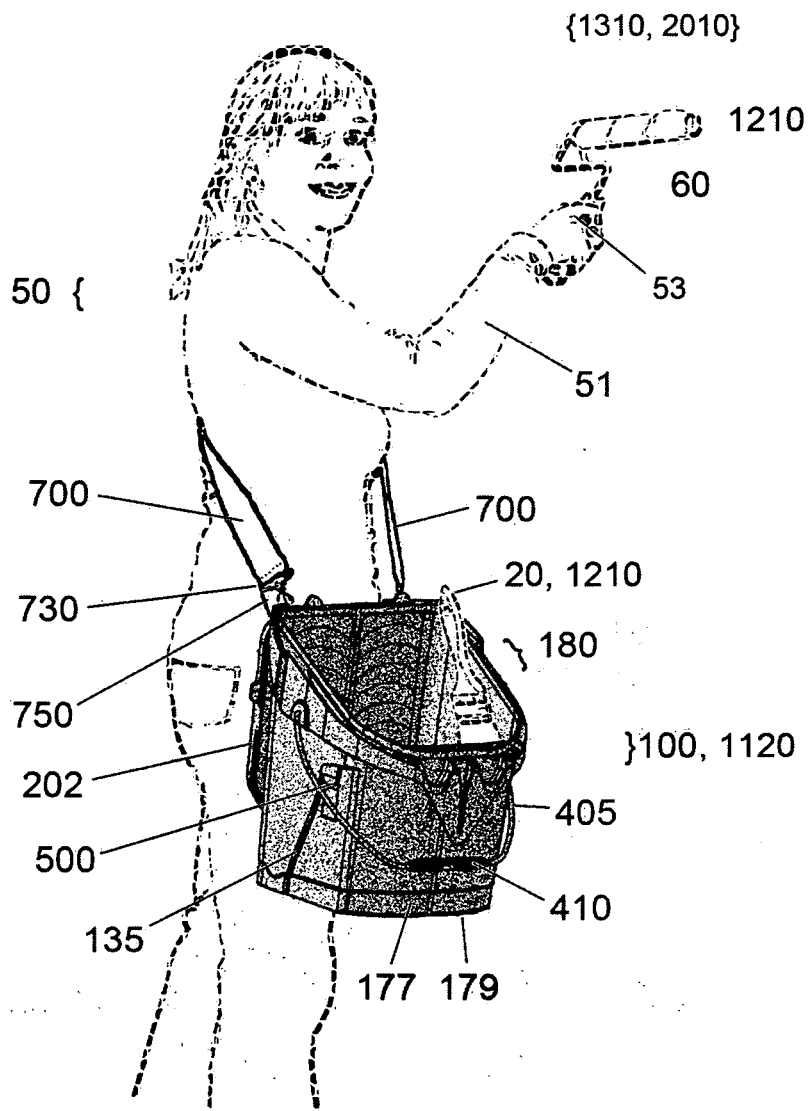

Fig. 5

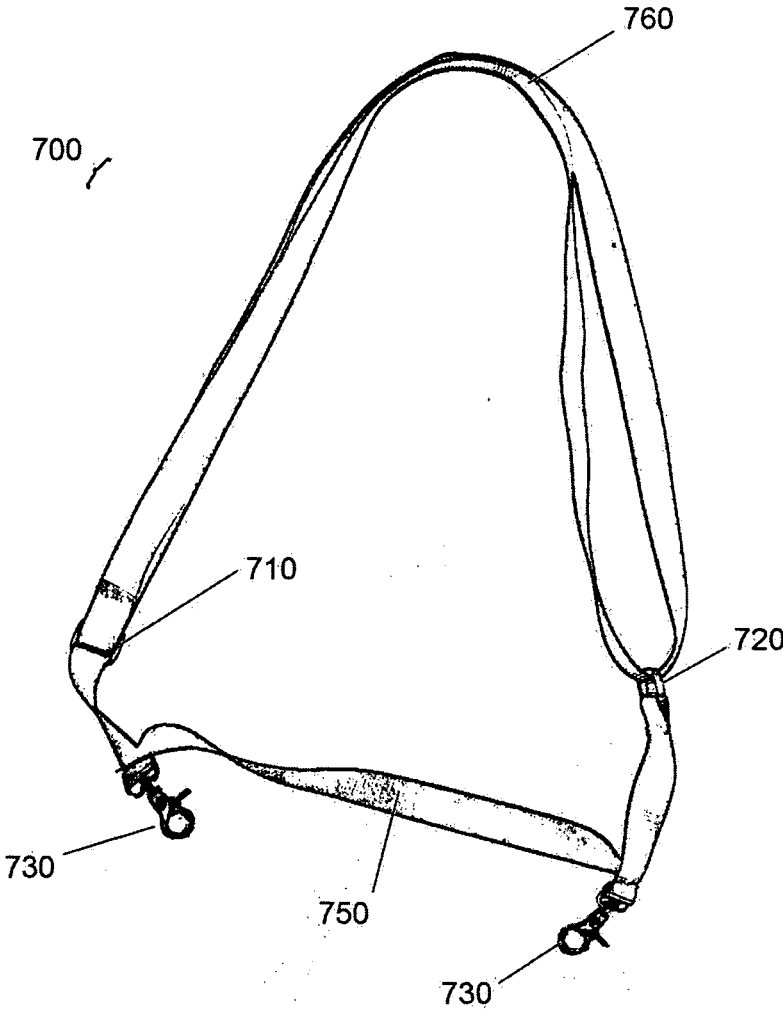

Fig. 6

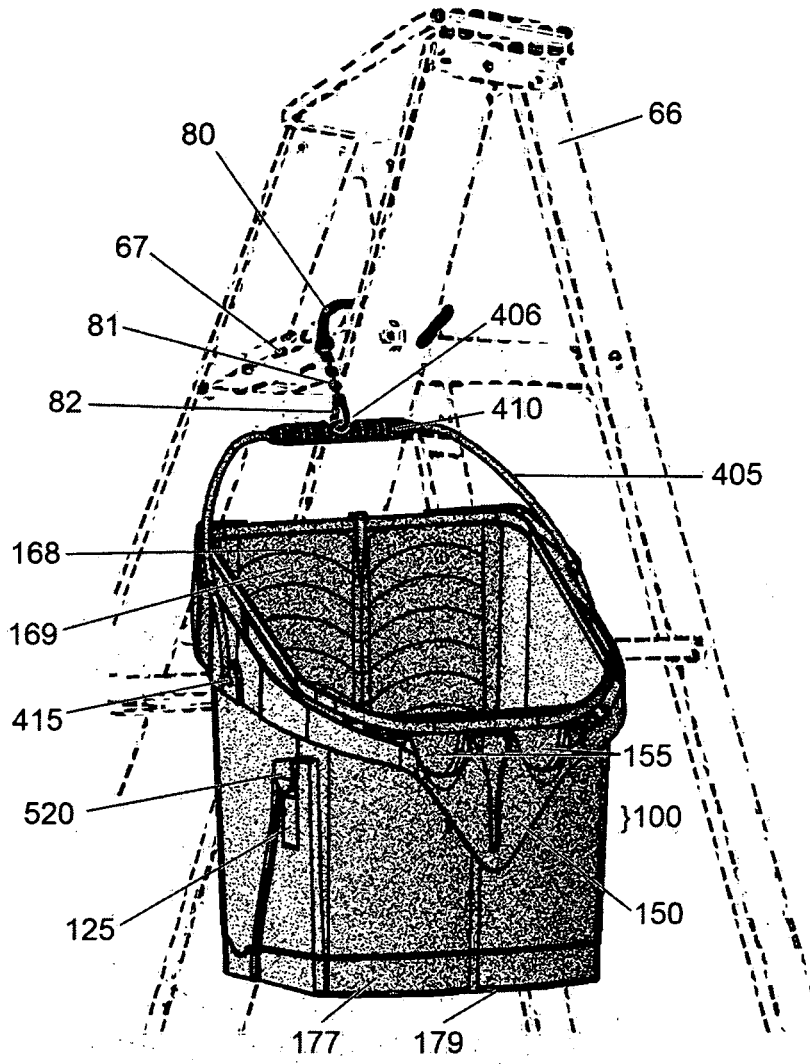

Fig. 7

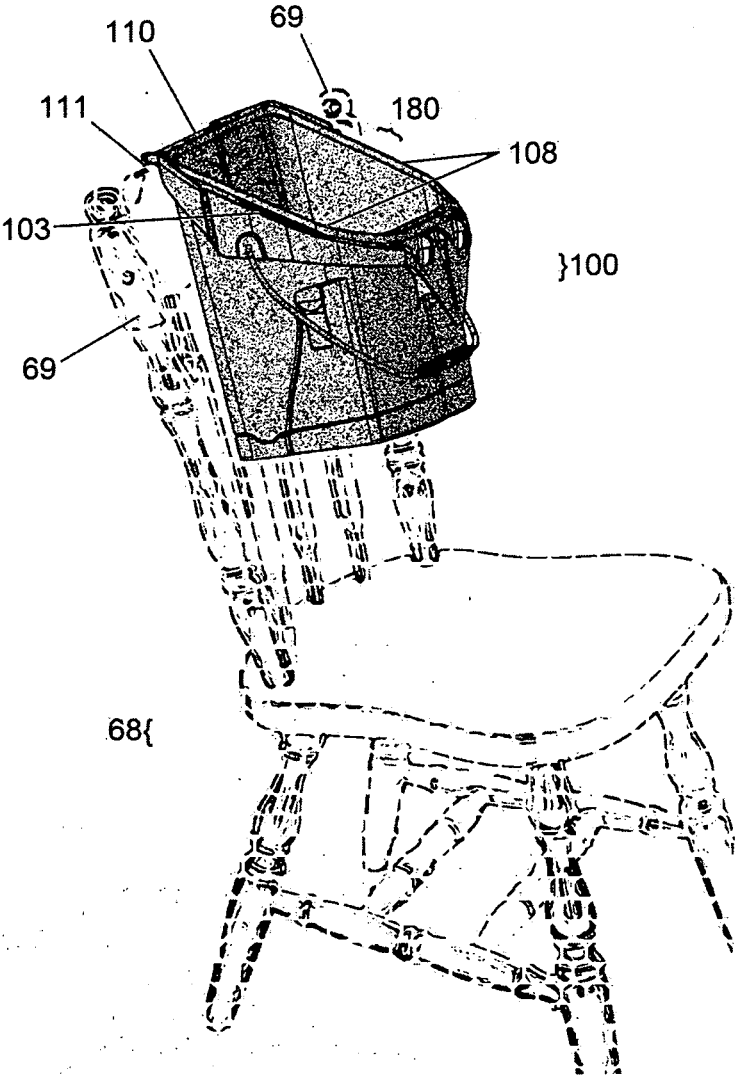

Fig. 8

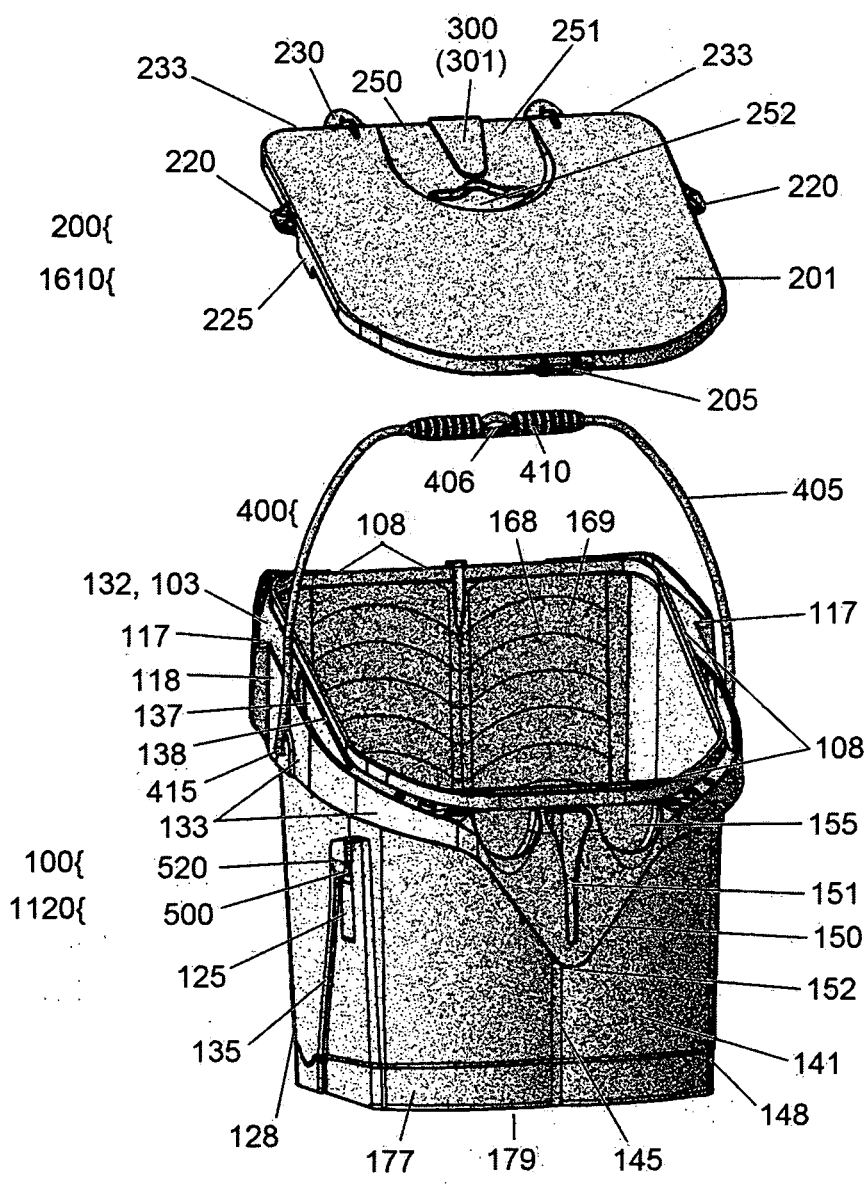

Fig. 9

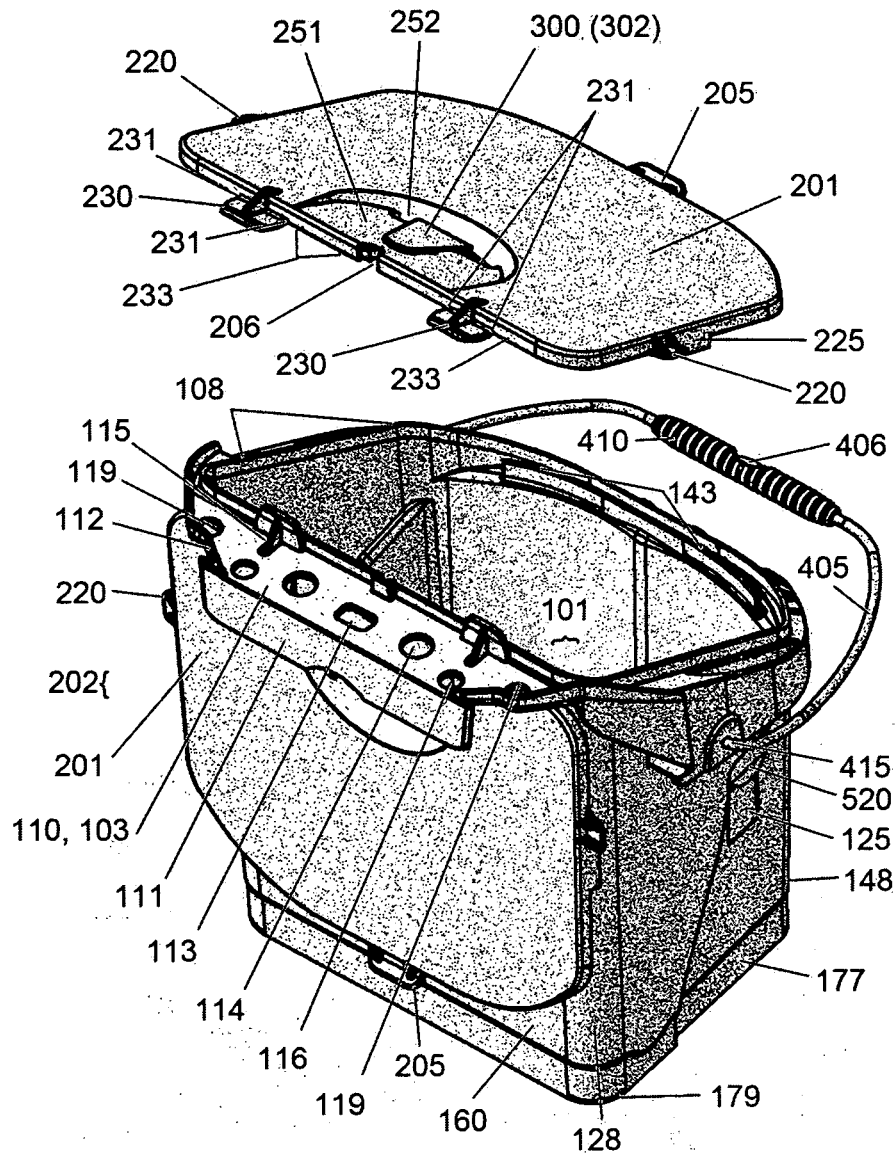

Fig. 10

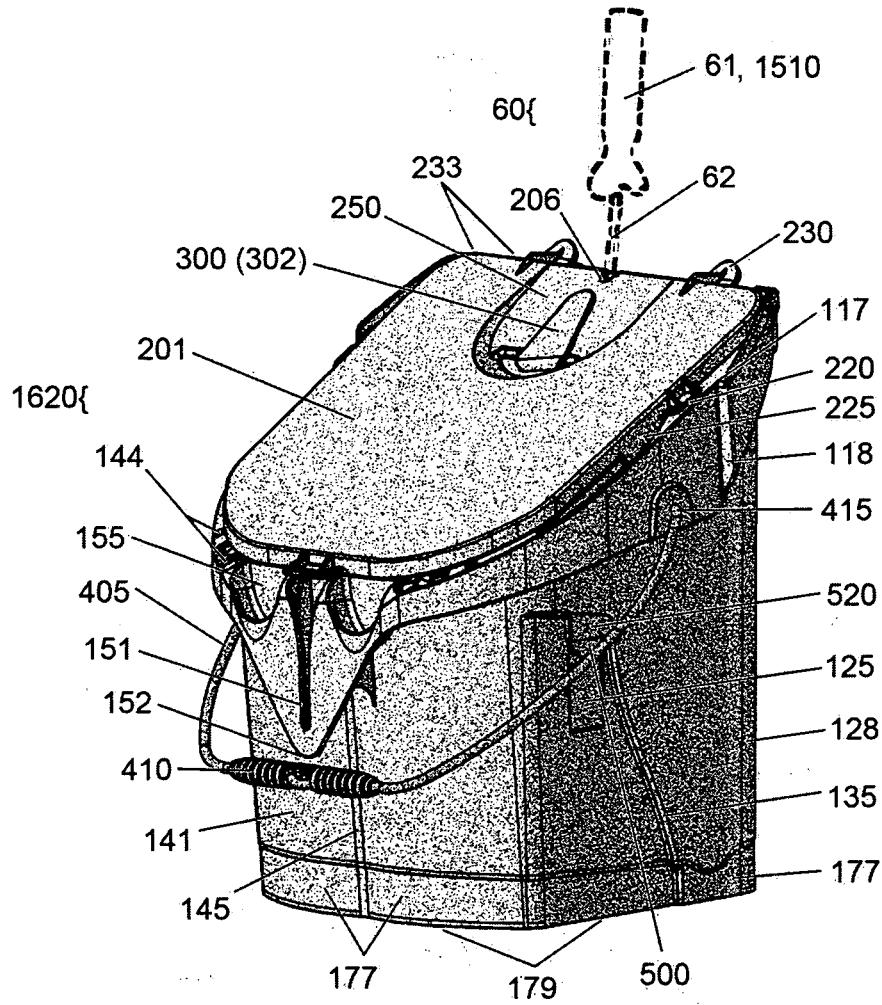

Fig. 11

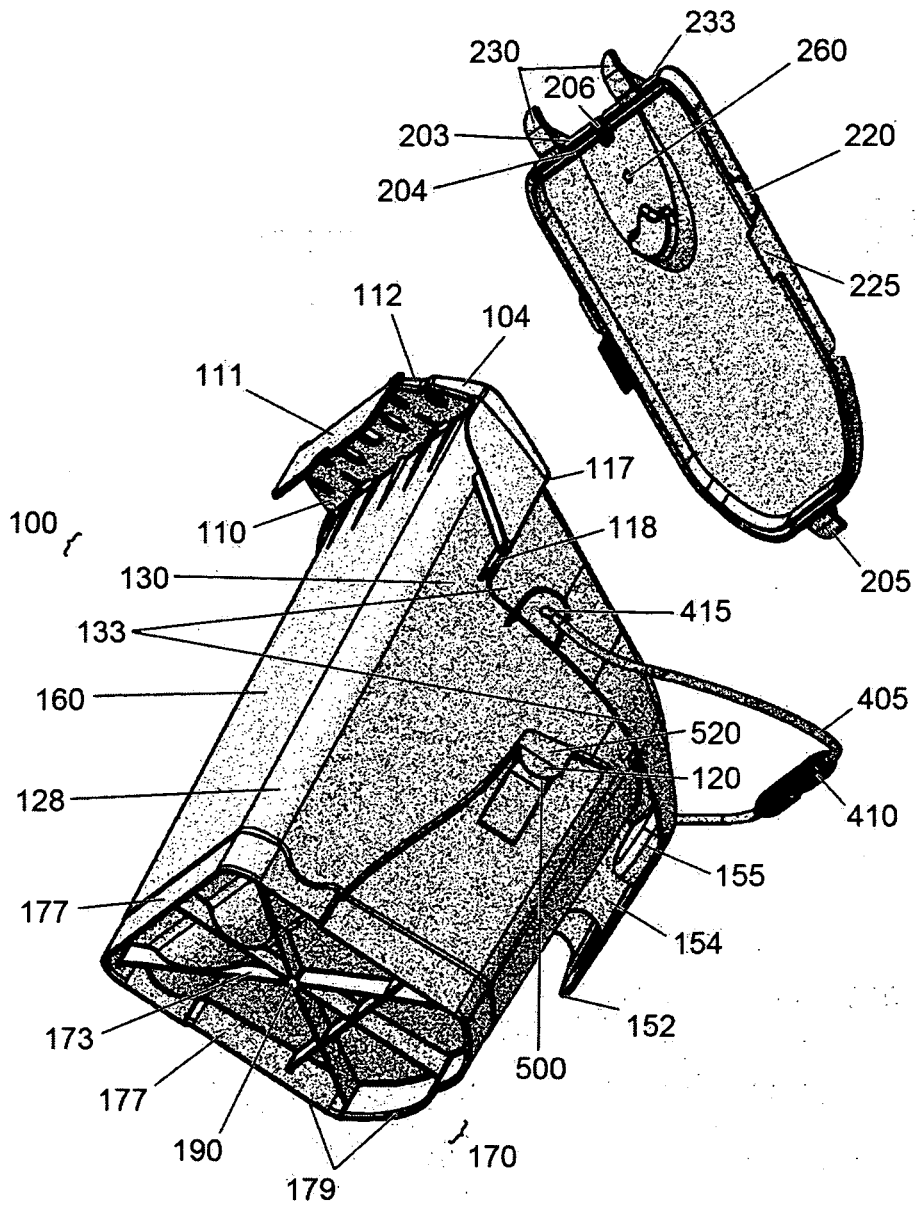

Fig. 12

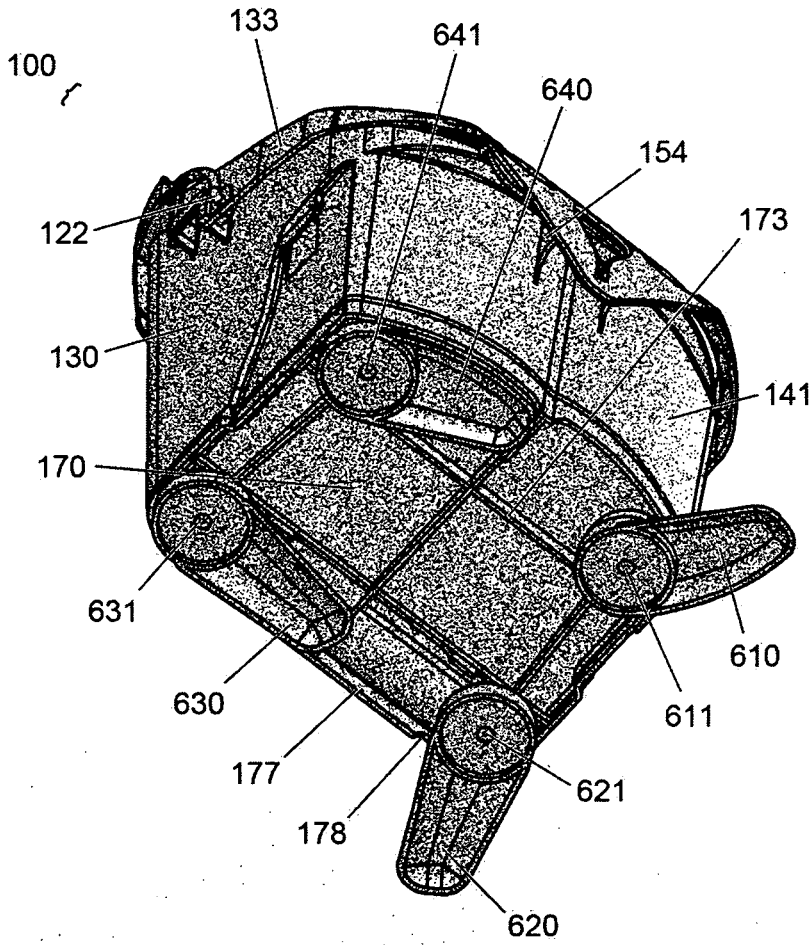

Fig. 13

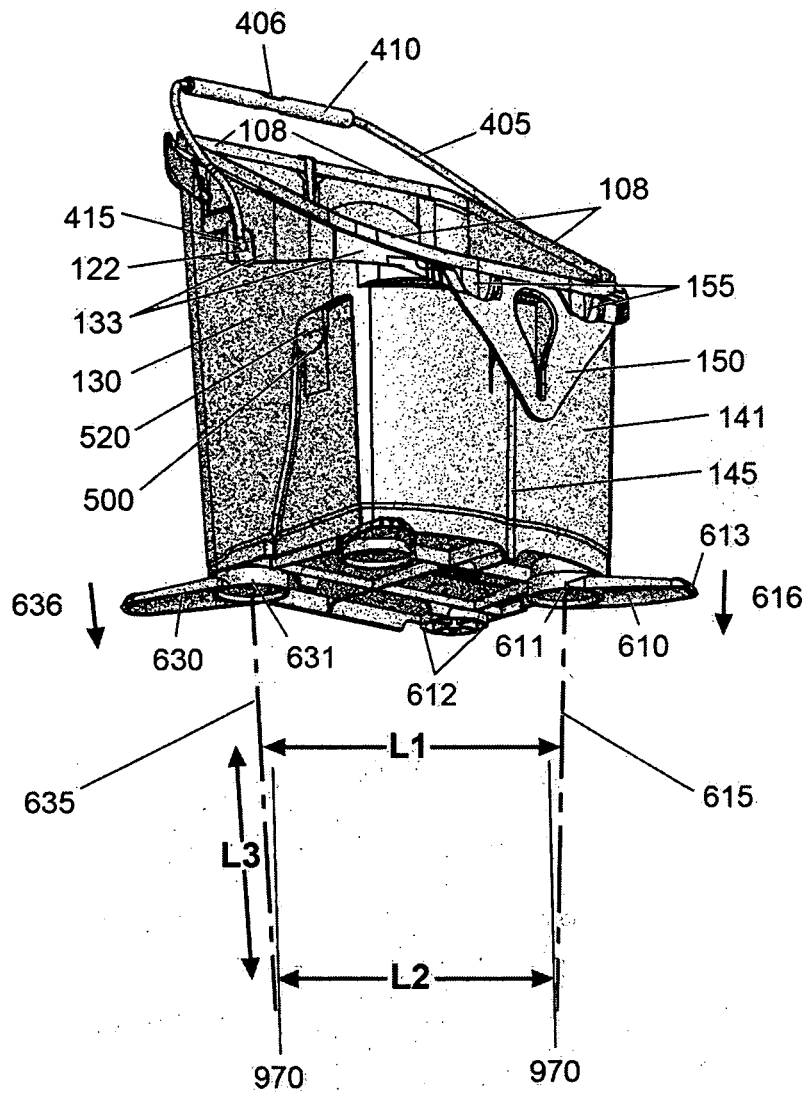

Fig. 14

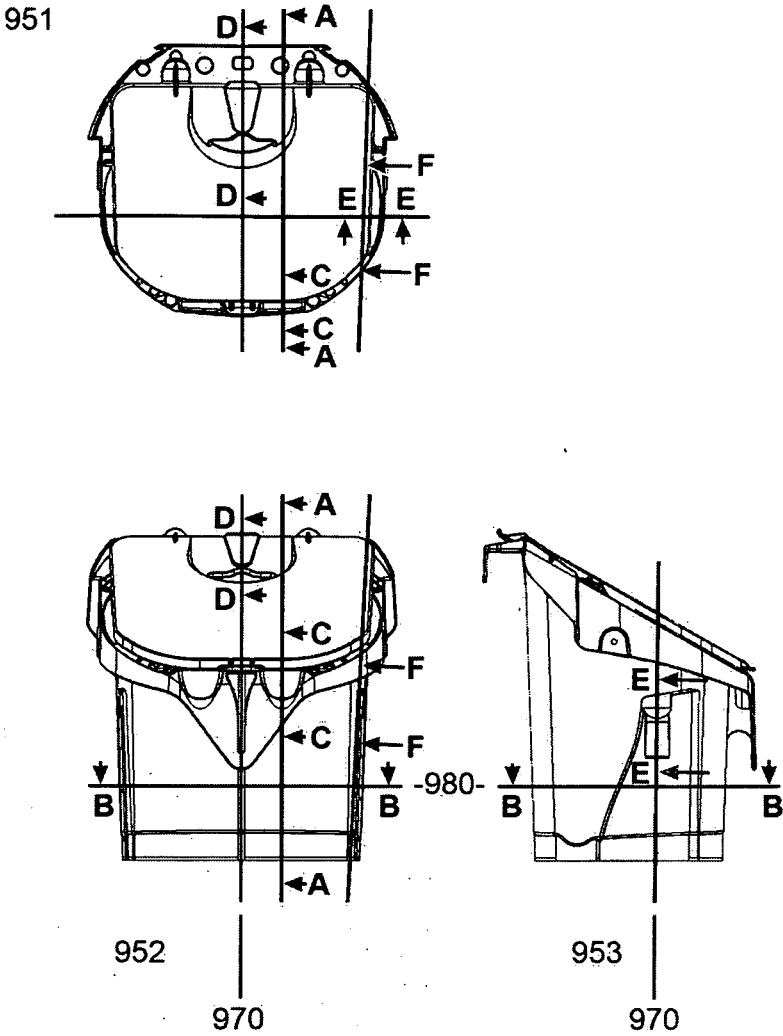

Fig. 15

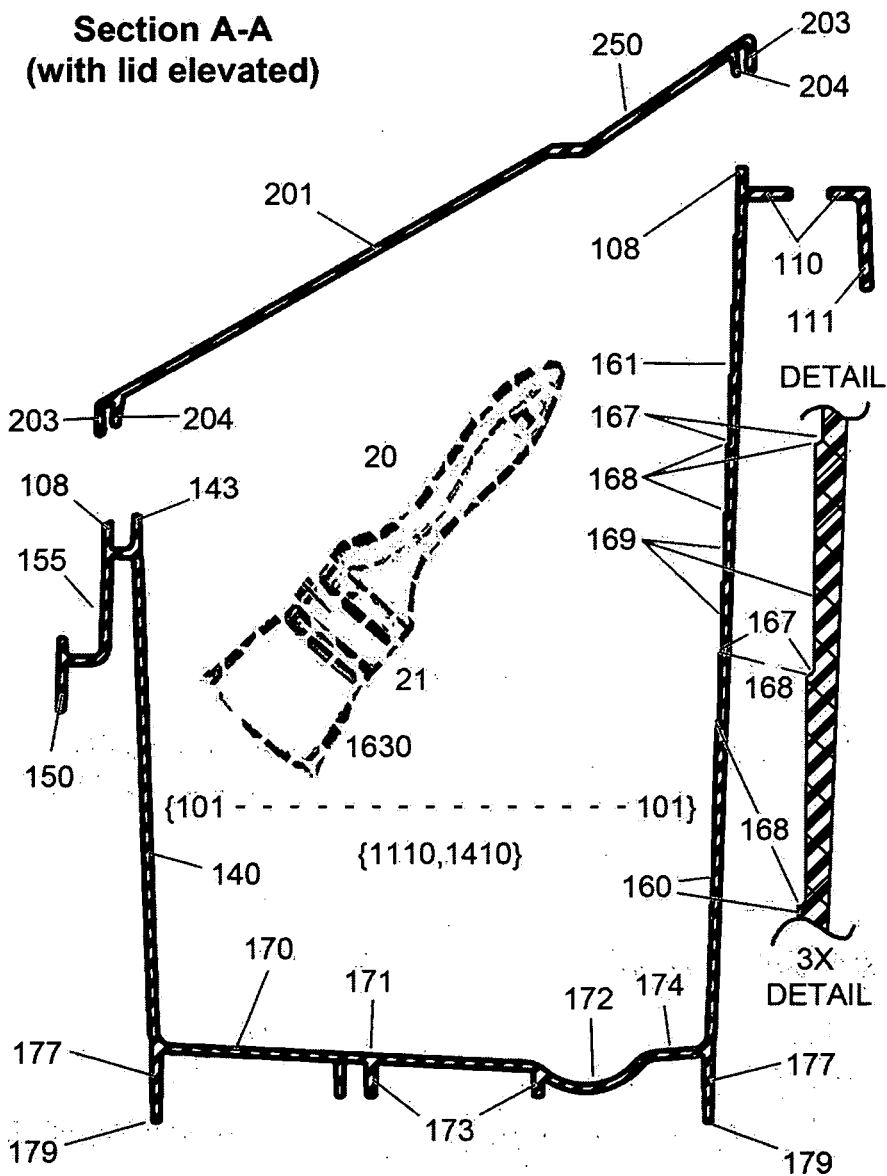

Fig. 16

Section B-B

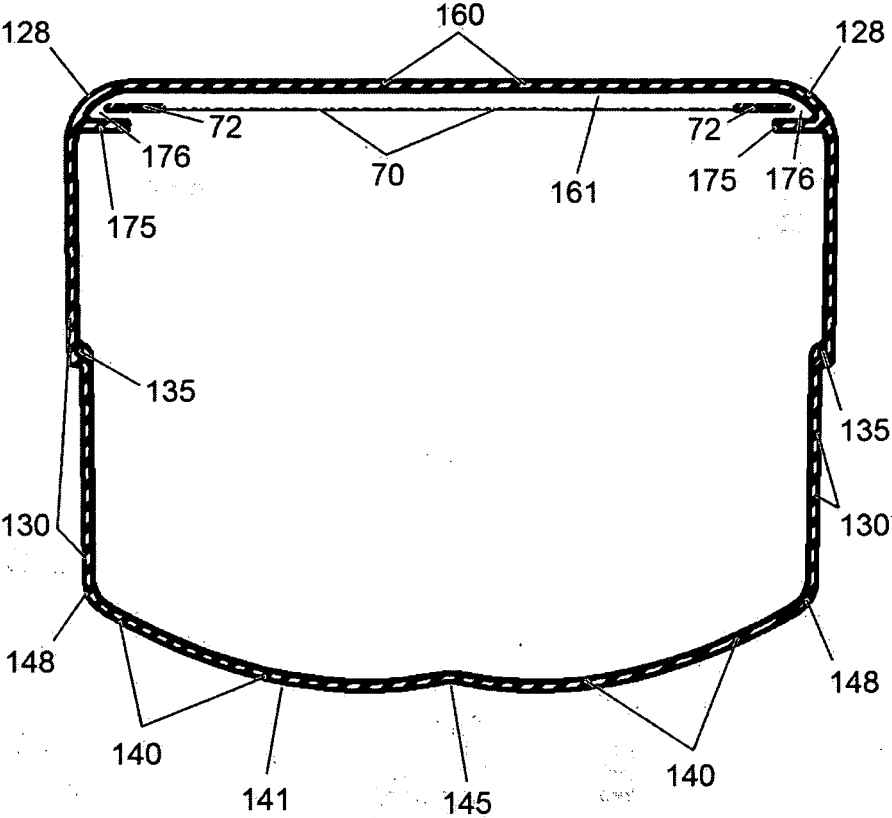

Fig. 17

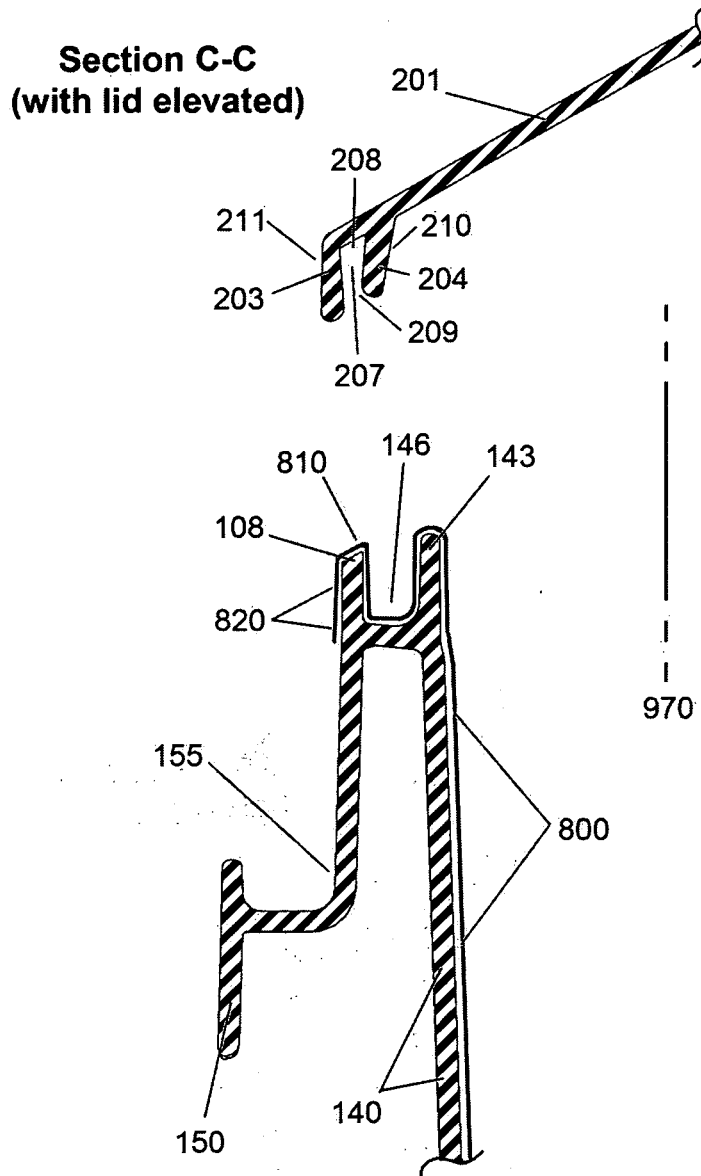

Fig. 18

**Section D-D
(with lid closed)**

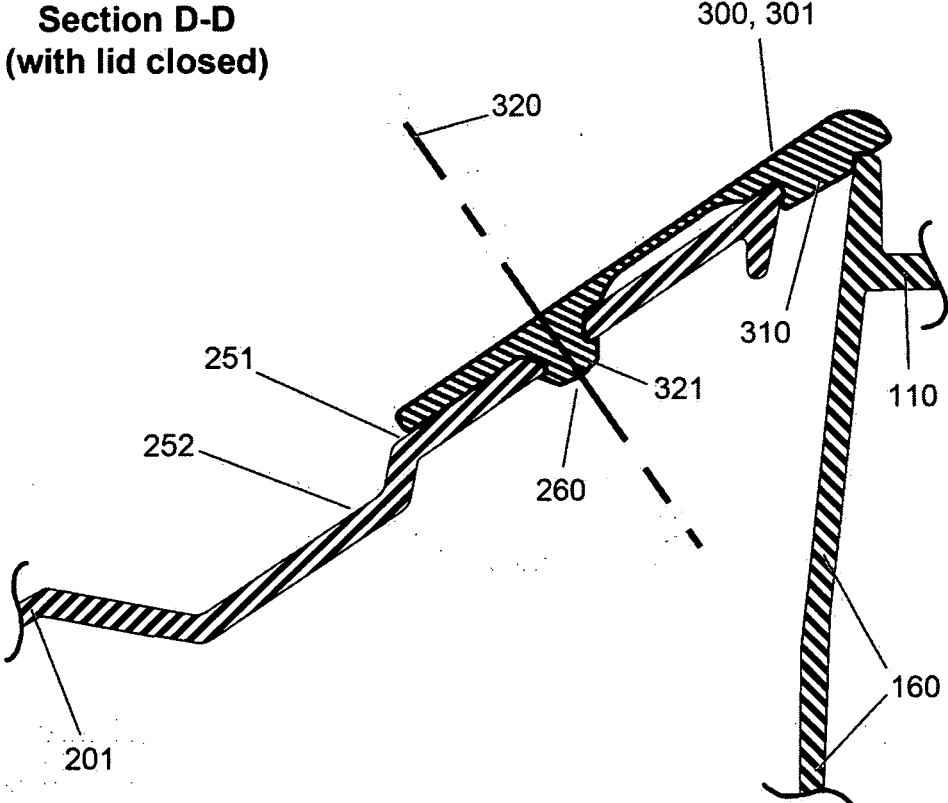

Fig. 19

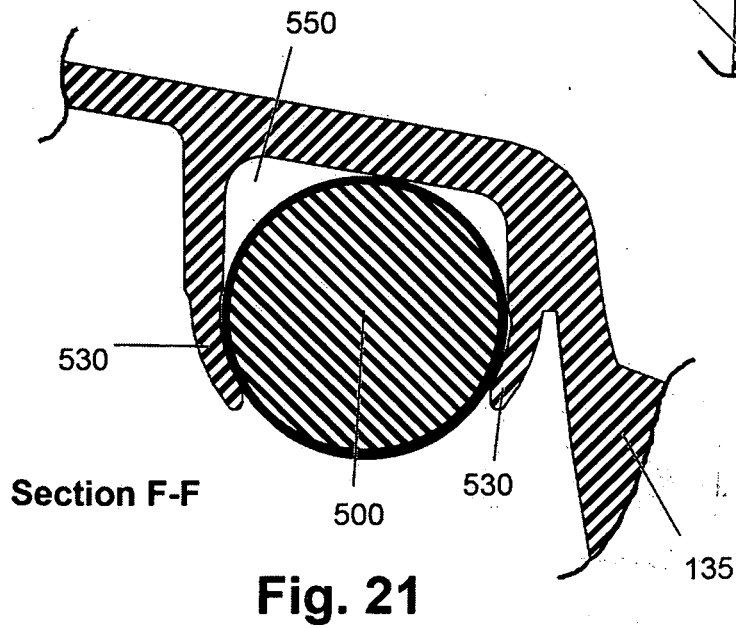
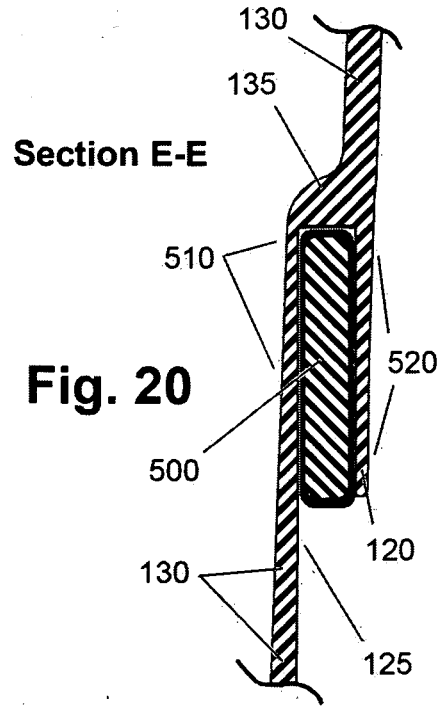

Fig. 22a

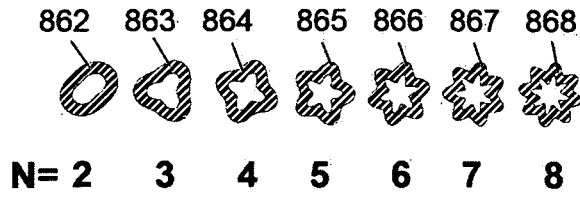

Fig 22b

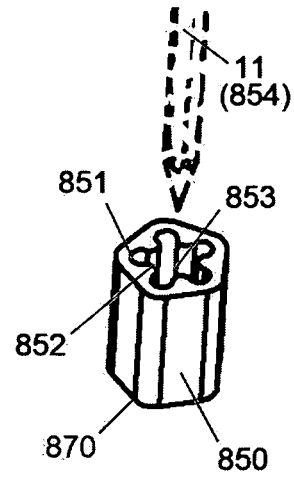
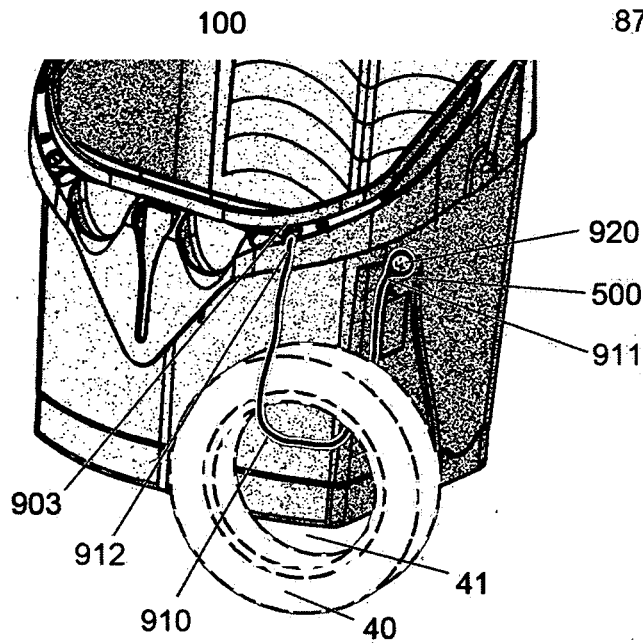
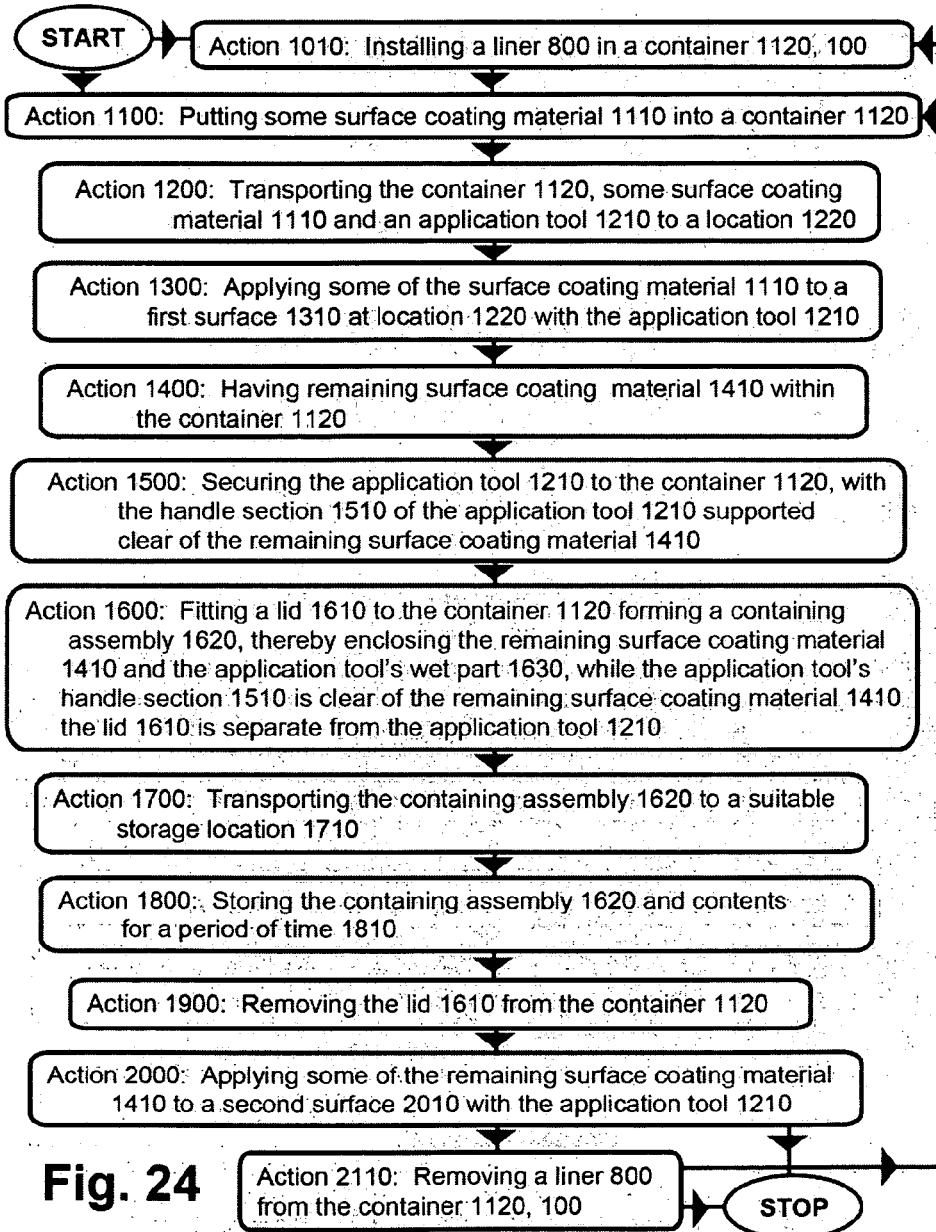

Fig. 23



Activity 1000: A method 1001 of applying and storing surface coating materials:



**METHOD AND APPARATUS FOR THE
APPLICATION AND STORAGE OF SURFACE
COATING MATERIALS**

RELATED PRIOR APPLICATIONS

- [0001]** This is a divisional application based on Application US 20120037634 A1
- [0002]** Publication number US 20120037634 A1 Publication type Application
- [0003]** Application number U.S. Ser. No. 13/135,382 Publication date Feb. 16, 2012
- [0004]** Filing date Jun. 30, 2011 Priority date Aug. 16, 2010 Also published as CN102423992A
- [0005]** U.S. Provisional patent ID No. 61/401,612 filed on date Aug. 16, 2010 is referenced for a priority date.
- [0006]** U.S. Design Pat. No. D643,983 S1, published on Aug. 23, 2011 is a related design patent to the present invention.

FIELD OF INVENTION

[0007] The present invention relates to the field of surface coating application and storage. The methods and apparatus in this field frequently employ: buckets, paint trays and other hand-carried containers for liquids and tools. In particular, the present invention provides improvements for the carrying, applying and storage of paint along with associated preparation and application tools.

BACKGROUND OF INVENTION

[0008] The standard horizontal paint roller tray, and application methods using one, have remained in wide use despite many inventions directed at improving the worker's access to surface coating material and at providing a roller paint distributing or spreading surface in convenient proximity to a stable paint-holding reservoir. Various covers have been made for paint trays allowing material storage. Putting the tray in a plastic bag along with tools is a known method for between job storage of tools and supplies.

[0009] Some of the impetus for the present invention comes from the various shortcomings of the standard horizontal roller pan.

[0010] The problems with the standard pan include: lack of stability when used on a ladder; small paint capacity; and lack of portability. The instability experienced while a horizontal roller tray is carried has been demonstrated over the years and is known to all those skilled in the art of roller painting. Using a roller tool and a brush on the same job generally requires multiple paint containers, leading to clutter and lack of portability. A significant need exists for a more ergonomic alternative to the prevalent prior art. Washing of tools is a time-consuming task that requires large amounts of water or other solvents and wastes material. These problems are addressed by the method and apparatus of the present invention.

[0011] From the year 1953, U.S. Pat. No. 2,659,917 by Drum teaches an improved surface for distributing paint on a roller for a horizontal paint tray. Drum provides a textured drainable surface where excess paint can be removed from the roller.

[0012] Currently it is common practice for people who paint with a roller to use a porous paint screen in a bucket, or to use a standard roller tray. Various specialty buckets are available which offer substantially vertical roller paint dis-

tributing elements. Several patents for such devices are listed below as well as other relevant prior art.

[0013] From 1961, U.S. Pat. No. 2,988,767, A. Tretwald, et al. teach a bucket with a flat vertical section on the inside to distribute paint on a paint roller.

[0014] From 1967, U.S. Pat. No. 3,351,970 by Engh, teaches a paint container with a substantially vertical paint distributing surface. Engh teaches the use of a shoulder strap, a bail handle and a means of attaching the container to the front of a ladder. The Engh tray may be used in a horizontal or vertical position.

[0015] From 1969, U.S. Pat. No. 3,425,012, Gottinger teaches the use of a magnet for securing a paintbrush to the side of a metal paint can.

[0016] From 1970, U.S. Pat. No. 3,536,285, Vaughn uses magnetic means for holding a paintbrush.

[0017] In U.S. Pat. No. 3,997,092 (1976), Pogwizd shows a harness and provisions for holding a brush and a paint scraper. Pogwizd also teaches the use of a pivoting lid.

[0018] In U.S. Pat. No. 4,101,046 (1978), Puntillo uses a magnet to suspend a paintbrush over a paint can.

[0019] From 1990, U.S. Pat. No. 4,964,601, Dishman discloses the use of elastic bands to attach a paint container to the side of a ladder.

[0020] From 1989, U.S. Pat. No. 4,860,891, Viggio discloses a paint and brush holder that incorporates a rear handle and, in front, a horizontal brush-grooming ledge.

[0021] In U.S. Pat. No. 5,046,749 (1991), Owens describes a paint-holding container where two of the vertical sides provide means of distributing paint on a paint roller.

[0022] In U.S. Pat. No. 5,928,843, Gunderson describes an invention which uses the lid of a paint container in a relocated vertical position to distribute paint on a roller.

[0023] In U.S. Pat. No. DES.321,070, Lewicki shows the ornamental design for a paint tray holder with paint roller support.

[0024] In U.S. Pat. No. 5,156,411, Owens teaches the use of a vertical roller surface in conjunction with a paint splatter shield.

[0025] In Fischer, et al, U.S. Pat. No. 5,207,348, the inventors describe an insert for a five-gallon bucket which includes a textured paint roller surface.

[0026] In U.S. Pat. No. 4,746,042, King provides a holder for a wet paintbrush that is worn on the user's belt.

[0027] From 1992, in U.S. Pat. No. 5,083,733 Marino, et al describe a brush holder incorporating a plurality of magnets.

[0028] In the 1990s a vertical roller paint tray with a rear-sided outward then downward protruding flange was sold in the country of Argentina. This container also incorporated a slanted open top, tallest in back, and a flexible cord handle, as well as horizontal striations in the rear wall. This container had rectangular plan-form shape, most narrow front to back with square corners; it was proportioned to work with a standard full-size paint roller.

[0029] In U.S. Pat. No. 5,033,704, Kerr teaches a magnetic brush holder incorporating a horizontal shelf.

[0030] In U.S. Pat. No. 5,276,943, Ludy discloses a handle for a paint can that facilitates suspending the can from a ladder.

[0031] In U.S. Pat. No. 5,201,439, Davies discloses a paint tray that can function with the roller paint-distributing surface oriented either horizontally or vertically. Davies also teaches the use of a roller-holding clip or notch.

[0032] In U.S. Pat. No. 5,402,910 Pilney discloses a paint container which can hang from the rungs of a ladder. His invention incorporates vertical roller paint-spreading surfaces, and a sealing lid is provided.

[0033] Ippolito, in U.S. Pat. No. 5,511,279, describes a stackable paint roller pan that has an enlarged one-quart capacity and an adjustable one-hand carrying handle.

[0034] Weber, in U.S. Pat. No. 5,400,916, describes a paint roller bucket which includes a steeply inclined roller paint distributing surface as well as a pivoting bail handle and a pour spout.

[0035] In U.S. Pat. No. 5,493,751, Misiukowiec et al describe a paint pan which can hang on the rung of a ladder and has a vertical roller paint distributing surface. The invention provides a lid, and is designed to function also in a substantially horizontal position.

[0036] King, U.S. Pat. No. 5,695,098, discloses a belt- or strap-supported holder for a wet paint brush or roller.

[0037] Moffitt, U.S. Pat. No. 5,641,087, presents a paint bucket for a mini-roller which includes a central wedge-like structure comprising two nearly vertical roller paint distributing surfaces.

[0038] Scholl, U.S. Pat. No. 5,549,261, describes a paint holder and delivery device which includes a removable, but non-disposable, liner.

[0039] From 1998, U.S. Pat. No. 5,746,346, Crilly describes a paint carrier which incorporates a non-magnetic brush holder on the inside of the paint-holding container.

[0040] Lundy, U.S. Pat. No. 5,810,196, describes a paint bucket which incorporates a brush-holding recess and a porous, inclined roller paint-distributing grid.

[0041] Ahl, et al, in U.S. Pat. No. 5,842,253, describe a ladder-supported paint-holding tray with notches for supporting a paint roller.

[0042] Rovas, in U.S. Pat. No. 5,836,043, teaches a paint tray with a specialized bail handle that enables the container to hang from the rungs of a ladder and also to be used flat on a horizontal surface.

[0043] Kohns, U.S. Pat. No. D477,702 S, discloses the ornamental design for a paint bucket with a bail handle and a substantially vertical roller paint distributing textured surface.

[0044] Malvasio, U.S. Pat. No. 6,138,963, describes a paint cup and brush holder incorporating a handle and pour spout. It is molded to provide for relatively compact stackability.

[0045] Butschat, U.S. Pat. No. 6,283,345 B1, describes a paint container system which can be worn on the user's belt and includes a means of holding a wet brush within the container.

[0046] Eisenbelsz, U.S. Pat. No. 6,431,392 B1, describes a detachable handle mechanism for carrying a conventional paint roller tray pan.

[0047] Fellman, U.S. Pat. No. 6,260,730 B1, describes an insert for a standard paint bucket, which provides a substantially vertical roller paint distributing surface.

[0048] Byrne, U.S. Pat. No. D546,514 S, describes the ornamental design for a paint bucket that includes a substantially vertical roller paint distributing surface.

[0049] Bergman, U.S. Pat. No. 6,991,829 B2, describes a hand-held vessel for holding paint which incorporates an adjustable handle as well as a brush-holding magnet.

[0050] Martelly, U.S. Pat. No. 6,769,136 B1, teaches the use of an apron and a paint container in combination.

[0051] Kent, U.S. Pat. No. 6,929,225 B1, describes a clip with a brush-holding magnet for use on the side of a paint container.

[0052] Ford, U.S. Pat. No. 6,945,440 B1, describes a paint bucket which has a hinging lid and a flexible strap.

OBJECTS OF THE PRESENT INVENTION

[0053] A primary object of the present invention is to provide painters with convenient and ergonomic method and means of transporting, storing, and applying surface coating materials.

[0054] A primary object of the invention is to provide a secure sealing lid, which can be equipped with a notch that allows the handle of a paint roller tool to protrude from the container while the paint-wet portion of the roller tool is protected from drying out within the container.

[0055] A further object of the invention is to provide a moveable flap, which can be used to seal the notch hole in the lid when no paint roller tool handle is in place.

[0056] A primary object of the invention is to provide temporary means of supporting a paintbrush or similar tool within the container, such that its handle is above the level of the liquid paint. It is a further object of the present method and apparatus to store a brush inside while the sealing lid is in place, forming a containing assembly.

[0057] A further object of the present invention is to provide magnetic means of holding a paintbrush or multiple brushes in a secure position within the container, which enables them to drain excess paint back into the container.

[0058] An additional object of the invention is to provide a bi-functional means of simultaneously securing tools on either side of a magnet located within a wall of the container.

[0059] A further object is providing specific means for carrying a plurality of paint-spreading, repair and clean-up tools. The present invention is intended to facilitate effective dispensing, storage and applying of paint and other coating materials.

[0060] An object of the invention is to provide an outward-then downward-turning flange that encircles the top opening of the container; the flange with its holes and lobes can receive, store and transport a plurality of tools and supplies.

[0061] An object of the invention is to provide specialized holes and magnetized receptacles for receiving tools and supplies. The tools for which receptacles are provided can include, but are not limited to: paint rollers, paint brushes, paint scrapers, cleaning cloths, putty knives, screwdrivers, standard pencils, carpenter's pencils and tape measures.

[0062] An object of the invention is to provide a cloth-holding receptacle, or a plurality thereof, that can be comprised in the tool-holding flange, thereby providing convenient means of storing a cloth for clean-up purposes.

[0063] A further object of the invention is to provide for compact, jam-proof stackability, for storage and transportation of multiple containers.

[0064] Another object of the invention is to provide a novel easily-detachable shoulder strap which stays in place on the operator with or without a container attached.

[0065] Such a strap enables the operator to have hands free while using the invention to carry supplies and tools. This feature can be found helpful when working on a ladder.

[0066] A further object of the invention is to provide a container and tool holder which can be enclosed or stored entirely within a standard five-gallon paint bucket and lid.

[0067] A further object of the invention is to provide an outward and downward-turning flange around the top of the container, said flange being suitable for holding a plurality of tools.

[0068] Another object of the invention is to provide an angle on the open top of the container to allow easier access to its contents.

[0069] An additional object of the invention is to provide a replaceable liner for the container, where the liner can extend over and around the top sealing lip of the container, enabling the sealing lid to function approximately normally with or without a liner in place.

[0070] An additional object is to provide means of holding a porous paint spreader screen within the container which can provide stable means of effectively distributing paint on a roller; and where the screen will not interfere with installation of a sealing lid.

[0071] A further object of the invention is to provide multiple means of supporting the invention while in use, comprising means of resting on horizontal surfaces and means of hanging from ladders, knobs, shelves, ledges, cabinet doors, chair backs, etc.

[0072] An additional object of the invention is to provide retractable legs that provide additional stability for the invention when it is resting on a horizontal surface, but which can be folded away when the container is suspended from a ladder, carried, or the like.

[0073] An additional object of the invention is to provide a multi-position bail handle, which engages a stop and produces an ergonomic two-element handhold in conjunction with the invention's back flange.

[0074] An additional object of the invention is to provide a tool-holding slot in proximity to a magnet; the combination can securely hold a paint-scraping tool or putty knife.

[0075] An additional object of the invention is to provide means of holding painter's putty or the like.

[0076] An additional object of the invention is to provide means of holding a clip-on tool such as a tape measure, or a clip-on tool pouch capable of holding additional tools or accessories.

[0077] Another objective is to create an apparatus that is inexpensive to manufacture by being molded from plastic.

SUMMARY OF THE INVENTION

[0078] The present invention of a Method and Apparatus for the Application and Storage of Surface Coating Materials provides convenient and ergonomic method and means of carrying and using a liquid such as paint and/or a plurality of tools within a work or hobby environment. An embodiment is disclosed that can hold a quantity of paint as well as a variety of tools, which may be used in conjunction with the paint. A versatile handle can be provided, enabling the container to be comfortably carried and used with various different hand positions. An optional detachable shoulder strap is disclosed, which allows the user to transport the container while having both hands free for other needs. The container can be configured to hang securely on the side of a ladder as well as rest stably on a horizontal surface. A special rear flange can provide means of supporting the container on a cupboard door, chair, drawer, or doorknob. The apparatus of the present invention has proven itself to be useful in various activities that require a small collection of tools and materials, as well as in the primary tasks of painting and paint preparation. The

method of the present invention has proven to be a superior way to apply and store surface coating materials.

BRIEF DESCRIPTION OF THE FIGURES

[0079] FIG. 1. Front prospective view of an operator's hand holding the container of the present invention.

[0080] FIG. 2. Front prospective view of a portion of the apparatus of the present invention showing various associated tools and tool stowage locations.

[0081] FIG. 3. Top view of a preferred embodiment of the container of the present invention showing tool stowage flange, grid support web, etc., with the handle and grip in a forward position.

[0082] FIG. 4. Front prospective view shown depicting insertion of a paint-spreading screen.

[0083] FIG. 5. Painter using a preferred embodiment of the present invention showing a preferred carrying strap configuration.

[0084] FIG. 6. Preferred embodiment of the carrying strap loop.

[0085] FIG. 7. Perspective view showing the container element of the present invention suspended with a hook from a ladder rung.

[0086] FIG. 8. Perspective view showing the container element of the present invention suspended on a chair back.

[0087] FIG. 9. Front perspective view showing a preferred embodiment of the present invention with elevated lid and vertical handle position; a notch-sealing flap in lid is shown in closed position.

[0088] FIG. 10. Rear quarter perspective view showing the lid elevated and also alternately, the lid in a rearward stowed position, bail handle forwards; the notch-sealing flap attached to the lid shown in open position.

[0089] FIG. 11. A front perspective view of the main components of the apparatus of the present invention, with the lid in the closed position and a paint roller tool in storage position; the notch-sealing flap in the lid is shown open, to accommodate the roller tool handle shaft.

[0090] FIG. 12. A bottom perspective view of the container and lid, showing the lid elevated and the handle forward.

[0091] FIG. 13. A bottom perspective view, showing an embodiment of the container with pivoting legs in retracted and extended positions.

[0092] FIG. 14. A lower perspective view showing the preferred non-parallel axes of diagonal leg pivots.

[0093] FIG. 15. A three-view drawing showing the locations of the various sectional views used in the figures, the container and lid are shown with the lid closed, forming a containing assembly.

[0094] FIG. 16. A cross sectional view taken on a vertical plane A-A in FIG. 15, shown with the lid elevated.

[0095] FIG. 17. A cross sectional view taken on a horizontal plane B-B in FIG. 15, shown with the paint spreading screen in place.

[0096] FIG. 18. A detail cross sectional view of the container, liner and lid, taken on a vertical plane C-C in FIG. 15, shown with the lid elevated, liner in place; the figure shows a cross section of the liner going over and around the brush grooming lip; this section is taken on the same plane as FIG. 16.

[0097] FIG. 19. A detail cross sectional view of the lid, flap and container taken on a vertical plane D-D in FIG. 15, shown

with the lid closed and the lid flap closed, this view is taken on the vertical mid-plane defining the container's possible symmetry.

[0098] FIG. 20. A front detail cross sectional view of a magnet within a side wall of the container, taken on a vertical plane E-E in FIG. 15.

[0099] FIG. 21. A side detail cross sectional view of a magnet within a side wall of the container, taken on a vertical plane F-F in FIG. 15.

[0100] FIG. 22a. A series of cross sectional views of elastic collar stops with different numbers of periods of waviness 'N'.

[0101] FIG. 22b. A perspective view of a pencil prior to insertion in an elastic tool stop collar (N=5).

[0102] FIG. 23. A perspective view showing a preferred embodiment of a tape roll holder.

[0103] FIG. 24. A flow chart showing the method of the present invention for applying and storing surface coating materials

DETAILED DESCRIPTION OF PREFERRED EMBODIMENTS

[0104] Exemplary preferred embodiments of the present invention are disclosed herein with reference to the several drawing figures. It will be understood by one skilled in the art that the various features and elements disclosed herein may be assembled in a multitude of alternative combinations and still fall within the scope of the present invention.

[0105] This description of exemplary preferred embodiments is provided as specific examples of embodiments within a group of variations, and it will be understood that this description and disclosure is not intended to limit the scope of the invention except as specifically announced in the claims.

[0106] Description of the Apparatus of the Present Invention:

[0107] The present invention provides an improved apparatus for applying and storing surface coating materials, whereby surface coating material may be efficiently stored and applied to diverse surfaces over a period of time without having to remove the coating material from the container or having to wash application tools, thereby saving time and materials.

[0108] The transportable container 100 shown in FIG. 1 can have an open top 180; the container 100 can hold a quantity of surface coating material 1110 (FIG. 16) and at least one application tool 1210 (FIG. 2). The application tool 1210 can have a handle section 1510 and a wettable section 1630, which is intended to be dipped into surface coating material 1110. Application tools 1210 include, but are not limited to: paint roller tools 60, paintbrushes 20, sponge tools, faux finish rag tools 90, spatulas 30, and paint spreading tools.

[0109] The transportable container 100 has an interior and an exterior, and a bottom part 170 that can support the container 100 in a stable manner when the container 100 sits normally on a flat and level surface. The open top 180 can be inclined to the horizontal at an angle of up to approximately 45 degrees, whereby easier access is provided to the surface coating material 1110 inside.

[0110] The present invention provides a lid 200 (FIG. 9), which can fit over the open top 180 of the transportable container 100. The lid 200 can be configured to temporarily attach to the exterior of the container in a stowage location 202 (FIG. 2), the stowage location 202 being different from the position occupied by the lid when forming a containing

assembly 1620 (FIG. 11), whereby the lid 200 can be easily kept with the container 100 and it is immediately available to seal up the container 100, also when stowed 202 the lid 200 can be less likely to get misplaced or lost. The lid 200 can have extensions 230 configured to fit within receiving elements 115 on the exterior of the transportable container 100 when the lid 200 is installed in its stowage location 202 (FIG. 10).

[0111] When the lid 200 is fitted a containing assembly 1620 (FIG. 11) is formed by the joined combination of the container 100 and the lid 200. The containing assembly 1620 can be substantially vapor tight, thereby preventing drying out of any enclosed surface coating material 1110 when the assembly is stored in a suitable location 1710 for a period of time 1810. The application tool 1210 can have a handle section 61, 1510, an intermediate shaft section 62 and a wettable section 65, 1630.

[0112] The lid 200 can have a notch 206 of a predetermined size allowing through passage of the shaft section 62 of the application tool 1210 and providing a substantially vapor tight seal therewith. The wettable section 65, 1630 of the application tool 1210 can then be enclosed within the containing assembly 1620 and protected from drying out while the handle section 61, 1510 of the application tool 1210 is exterior to the containing assembly 1620. A moveable cover 300 can be provided for the notch 206, which can block the slot 206 in the lid when no tool handle shaft 62 is in the slot 206. The moveable cover 300 can provide a substantially vapor tight sealing of the containing assembly 1620, whereby surface coating material 1110 may be stored inside the containing assembly 1620 and be protected from drying out for periods of time 1810 when no tool handle shaft 62 is occupying the notch 206. The moveable cover 300 can be captive and pivot about a predetermined axis 320. Alternatively the moveable cover 300 can be captive and attached to the containing assembly 1620 by a flexible element.

[0113] The present invention can provide securing means for supporting an application tool 1210 (FIG. 2) in a manner which allows the wettable section 1630 of the tool 1210 to be enclosed within the substantially vapor tight containing assembly 1620 (FIG. 11). The securing means additionally positioning the handle section 1510 of the application tool 1210 such that the handle section 1510 is clear of any surface coating material 1110, 1410 (FIG. 16) that is within the containing assembly 1620 (FIG. 11) when the assembly is sitting normally. The securing means can be magnetic means of temporarily attaching the application tool to the containing assembly 1620.

[0114] The magnetic means can comprise an individual magnetic element 500, which can be configured and placed in a region where magnetically attractable objects may be held on both the interior 510 and the exterior 520 of the container 100 by the same magnet 500, so that wet paintbrushes 20 can be held inside the container 510 and dry scraping tools 30 on the outside 520 at the same time.

[0115] The present invention can also provide a lineal flexible element 910 (FIG. 23), which is tied to the container 100. The lineal element can terminate in a magnetically attractable section 920 that can be detachably attached to a magnetic portion 500 of the transportable container 100. The lineal flexible element 910 can have some slack when the magnetically attractable end 911 is attached to the magnet 500 on the container 100. This combination can allow a roll of tape 40 to be transported by putting the attractable end 911 of the lineal

element **910** through the tape roll **40** and attaching the attractable end to the magnet **500**.

[0116] The present invention provides transporting means allowing for convenient movement of the container **100** from location to location **1220, 1710** by a person **50** (FIG. 5). The transporting means can comprise a detachable strap assembly **700** configured to temporarily attach the container **100** to a person **50**, allowing the person **50** to carry the transportable container **100** without gripping it in their hands, whereby the person **50** may have hands free to use application tools, support themselves, or perform other actions. The strap assembly **700** (FIG. 6) can adjustably engage a person's neck, or shoulders, or waist, or torso, or a combination thereof, whereby depending on the nature of the job the container **100** may be attached to the person **50** in a variety of different ways.

[0117] The present invention can also provide means of temporarily attaching the transportable container **100** to a supporting element, including: ladders **66**, scaffolding, chairs **68**, doors, fences, knobs, hooks, and lanyards (FIG. 7, FIG. 8); thereby allowing the container **100** to be positioned and stabilized in a convenient position when in use. The means of temporarily attaching the transportable container **100** to the supporting element can comprise: hooks **80**, clips **82**, and flange extensions **110, 111** of predetermined shape.

[0118] The present invention can also provide a liner **800** (FIG. 18) installed **1010** in the container **100, 1120** prior to putting the surface coating material **1110** into the container **100**, the liner **800** being of predetermined thickness, and being configured to allow substantially normal operation of the lid **200** and permitting formation of a containing assembly **1620** with a liner **800** installed. The liner **800** may be optionally used and removed **2110** to facilitate color change or clean out. The liner **800** can be constructed of thin flexible plastic material of a thickness between approximately 0.002" and 0.012". The thickness being sufficiently thick to resist puncture in normal use, yet sufficiently thin to fit between the container and the lid when a containing assembly **1620** (FIG. 11) is formed, thereby allowing optional use of a liner **800** with the lid **200, 1610** and the container **100, 1120** combination.

[0119] The present invention can also provide a screen or grid **70** (FIG. 4), which can be substantially planar. The grid **70** can engage the container **100** and be securely yet removably positioned proximal to a substantially planar area on the interior of the container **100**. The grid **70** can fit within the containing assembly **1620** along with application tools **1210** in their secured positions. Using the grid **70**, surface coating material **1110** can be easily distributed on or removed from application tools **1210**. The grid **70** can be stored inside the containing assembly **1620** along with the wettable sections **1630** of application tools **1210** and any remaining coating material **1410**.

[0120] The present invention can also provide a plurality of extendable legs **610, 620, 630, 640** (FIG. 13) attached to the bottom part **170** of the transportable container **100**. The extended legs **610, 620, 630, 640** can give the container **100** extra stability when it is resting on a substantially flat and level surface. Each of the extendable legs **610, 620, 630, 640** can pivot about a separate substantially vertical axis (FIG. 14), whereby the legs **610, 620, 630, 640** can have good structural integrity in the vertical direction and yet pivot and fold up easily in a substantially horizontal plane.

[0121] The present invention can also provide a plurality of tool receiving extensions **116, 137; 144, 151** around the exte-

rior of the container, whereby additional tools may be transported and used in conjunction with the container **100** (FIG. 3).

[0122] The present invention can also provide a tool stop toroid **850** (FIG. 22), which can be constructed of elastic material and be of predetermined size and shape, such that the tool stop **850** securely engages the shaft portion **854** of a tool. The tool stop **850** can be of sufficient size and shape to engage the tool receiving extensions **116, 144** on the transportable container **100**, whereby a tool stop **850** around a tool **854** can prevent the tool **854** from sliding past the tool receiving extensions or through receiving holes **116, 144** on the container **100**.

[0123] The present invention can also provide multifunctional magnetic means **500, 530, 550** (FIGS. 20, 21) for supporting an application tool **1210** in a manner that provides easy access to its handle section **1510** and allows the wettable section **1630** of the application tool **1210** to drain back into the interior **101** of the transportable container **100** when the container **100** is sitting normally. The multifunctional means can additionally provide temporary magnetic securing of magnetically attractable items on the exterior of the container **520**, so that a wet application tool can be temporarily secured inside the container **510** and a dry article temporarily attached to the outside **520** by the same magnetic means **500, 550** (FIG. 2).

[0124] A wall section **130** (FIG. 20) containing multifunctional magnetic means **500, 550** can form part of the transportable container **100**. The multifunctional magnetic means **500, 550** can comprise at least one magnet **500** incorporated into the wall section **130** of the container **100**. The magnet **500** can be positioned in the wall section **130** so that magnetically attractable objects **21, 31, 920** (FIGS. 2, 23) may come in close proximity to the magnet **500** without being impeded by other material in the wall section **130**, whereby being closer to the magnet **500** provides stronger magnetic attraction for the tool **31** or other item **920**, and yet the magnet **500** is not exposed.

[0125] The present invention allows leftover paint and a wet tool, or a plurality thereof, to be sealed up and stored in a containing assembly **1620** (FIG. 11) for a period of time **1810** (FIG. 24) ranging from a few minutes to several months without washing the tool **1210** or container **1120**.

[0126] A preferred embodiment of a portion of the present invention, as disclosed in FIGS. 1 and 2, can comprise a container unit **100** with a flange **103** around an open top **180**. The flange **103** can have a plurality of tool receiving holes, pockets and slots **112, 113, 114, 116, 144, 151, 155**. Special 'T' shaped slots **115** can be provided to receive corresponding tabs **230** on the lid **201**.

[0127] A preferred embodiment of the present apparatus comprises: a container **100**, a lid assembly **200**, and means of securing coating application tools.

[0128] Some additional elements may be added to the above embodiment in order to provide additional functionality: a pivoting handle assembly **400**, a paint spreading grid or screen **70**, a carrying strap **700**, a removable liner **800**, and a tool storage collar stop **850**.

[0129] In a preferred embodiment, the container **100** of the present invention can be laterally symmetrical about a vertical plane passing through the middle of the container, this provides for complete ambidextrous functionality and can contribute to providing an ergonomic conceptual simplicity.

[0130] The container 100 can be capable of holding a quantity of liquid in a reservoir area 101 and/or a plurality of tools on a flange 103. The container can have a rear substantially planar wall 160 that is oriented in a near vertical position when the container is sitting on its bottom and resting normally on a horizontal surface.

[0131] The container 100 can have an open top side 180 which is at least partially surrounded by a substantially horizontal flange 103 protruding outward from near the top edge of the open top side 180. The flange 103 can contain holes 113, 114, 116, 119, 144 and/or recesses 155 for receiving putty and holding a tool or a plurality of tools. Portions of the tool flange 103 may be substantially vertical, like the side flange 133 and the rear flange 111. The side vertical flange 133 can be configured to hold a tape measure or similar clip-on item, including among other possibilities, a tool-holding pouch.

[0132] In an exemplary preferred embodiment of the container, the top opening 180 can slope downward towards the front at an angle of approximately 30 degrees from the horizontal.

[0133] In a preferred embodiment the container 100 can comprise a lip 108 extending vertically upward around the periphery of the open top 180 when the container 100 is resting on a horizontal surface. The lip 108 can be capable of receiving a substantially sealing lid assembly 200. In contrast to the prior art for clip-on lids, the lip of the present invention may be vertical while the open top is inclined at approximately 30 degrees from horizontal. Thus removal of the lid occurs in a vertical direction 970, rather than perpendicular to the surface of the open top and lid as is found in the prior art.

[0134] The container 100 can be molded from a semi-flexible plastic such as high-density polyethylene or polypropylene, and formed with four substantially planar walls: a rear wall 160, two side walls 130; a front wall 140; as well as a bottom 170 and an angled open top 180. An outwardly protruding flange 103 can be provided around the periphery of the open top 180. A vertical, upwardly protruding lip 108 can also be provided around the periphery of the open top 180. The lip 108 can be configured to receive a sealing or semi-sealing lid assembly 200 with suitably shaped extensions 204, 203.

[0135] Radiused corners 128 of approximately 1/2 inch radius can be provided where the side walls 130 meet the rear wall 160. When viewed from the top (FIG. 3), the reservoir portion 101 of the container unit 100 can have a trapezoidal shape where the side walls 130 are of equal length and the rear wall 160 is longer than the front wall 140. The side walls 130 will therefore be non-parallel. This feature can provide for more compact storage within a round storage space as may be found within a standard five-gallon paint pail. A optional object of the present invention is to constrain the dimensions of the container such that the complete apparatus can be stored entirely within a closed standard five-gallon paint pail.

[0136] As shown in FIG. 2, the present invention provides a painter with convenient means of transporting and accessing a supply of paint and associated tools such as: a paint roller tool 60; a paint brush 20; a scraper tool 30; a pencil 11; and a wiping cloth 90. A paint roller tool 60 can be hooked on the rear lip 108 of the container 100. A paint brush 20 can be held by a magnet 500 attracted to the brush's metal band 21 near a location 510 on the interior of the container 100. By rotating the handle of the attached paintbrush rearward, a lid 200 can be used to seal the brush entirely within a containing

assembly 1620 (FIG. 11). The magnet 500 can be located in a pocket 550 in the side wall 130 of the container 100 (FIGS. 20, 21). A putty knife or paint-scraping tool can be held by the combination of a magnet 500 on its outside edge 520 and an oblong hole 137 in a tool-holding flange 103 (FIG. 2). A vertical portion 133 of the tool-holding flange 103 can be provided proximal to the outer side of tool hole 137. The vertical portion 133 proximal to hole 137 provides a handy element to clip on a tape measure or a clip-on tool-holding pouch.

[0137] With reference to FIGS. 1 and 16, the interior surface of the rear wall 161 can be provided with a textured surface 162. A detail view of the texture pattern is shown in FIG. 16. The texture can be in the form of a pattern of approximately horizontal ledges 168 that extend approximately 0.025 inch into the reservoir area, then have an approximately vertical downward section of about 0.8 inch 169, then another approximately horizontal ledge 168. A radiused fillet 167 of approximately 0.025 inch radius can be provided in the concave corner where a ledge 168 meets a face 169. This radius can make the textured pattern easier to clean while maintaining traction on the roller. The net horizontal offset per ledge including the fillet can be approximately 0.025 inches.

[0138] When seen from the front, the ledges 168 can form a series of laterally symmetrical curves that have outer sections that form an upwardly convex curve of approximately 2.5 inch radius, said curves meeting along the invention centerline in a slightly rounded vertex 165, with an upwardly concave radius of about 1/2 inch. This pattern of ledges can provide extra traction for the roller as it is rolled on the container's substantially planar rear wall. This pattern is provided as a backup measure. For optimal performance, a separate paint spreading screen or grid 70 is provided by the invention.

[0139] The paint-spreading screen 70 of the present invention provides a combination of improvements over the prior art. In a preferred embodiment the paint-spreading screen 70 is a substantially planar assembly without any hooks on its top side 71. Hooks on the top edge are the norm in the prior art. Hooks are a versatile means of securing a screen in a variety of buckets, but the hooks tend to interfere with installing a sealing lid 200 on the container 100. The lid 200 can be useful for temporary storage of paint and painting equipment 60, 20, 30.

[0140] In a preferred embodiment of the present invention the paint spreading screen (or grid) is engaged to fit securely in place within the container 100 by means of two slots 176 (FIG. 17) formed into both side walls 130 of the container in their respective lower portions. The slots 176 can be formed by the combination of inwardly protruding webs 175 on the side walls and the interior surface of the rear-side corner wall 128. The slots 176 can engage the side beams 72 in their lower portion 73 and the spreading screen assembly 70 is positioned in place as shown in the cross sectional view of FIG. 17; the position being nearly parallel to and slightly offset from the rear wall 160 of the container 100. Depending on the qualities of the liquid being rolled and the roller nap, an appropriate offset could be 1/8 inch at the bottom 75 and somewhat less at the top 71 of the screen 70.

[0141] To position the screen 70 in an effective and secure position it can be desirable to provide the lower portions on the screen side beams 73 with a slight curvature 74, which is concave to the side facing rearwards. This curvature 74 can easily be adjusted by hand bending of metal side beams 72.

The top **71** and bottom **75** edges of the screen benefit from deburring, but do not generally require supporting beams.

[0142] A pivoting bail type handle assembly **400** with special stop elements **117** (FIG. 3) can be provided by the present invention. The handle can be configured to pivot from a hole **122** in the container **100** vertical side flange **133**, along a pivot axis **415**. The handle can have a suitable bail **405** length such that the handle grip **410** will swing clear of the lower end of the cloth-holding flange **152** when swung forwards and down for stowage. At the other extreme of its swing travel the bail portion **405** of the handle assembly **400** can be configured to engage stop elements **117** on the container's outward side flanges **132**.

[0143] By engaging the stops **117**, the grip element **410** of the handle assembly **400** is positioned in a location approximately three inches above the corner defined by intersection of the horizontal rear flange **110** and the vertical rear flange **111**. In this position, the combination of the handle grip **410**, the bail **405** and the two rear flanges **110**, **111** can form an ergonomic hand hold for gripping the invention, as depicted in FIG. 1.

[0144] With reference to FIGS. 3 and 7, a preferred embodiment of the present invention can be provided with a pivoting handle assembly **400** formed partially of a rigid material such as wire **405**, and with a resilient enlarged diameter gripping portion **410** in its central section. The central bend in the handle bail element **405** and a cutout **411** in the resilient grip element **410** form an opening **406** configured to provide convenient means of securely attaching a detachable connector **82** to the handle near its middle. The detachable connector **82** (FIG. 7) may be integrally joined to a flexible element **81** and to a ladder hook **80**, which enables suspending the container **100** from a ladder rung **67** or other structural member. Alternately, the connector **82** may be joined to a hoisting element such as a cord or rope for securing or elevating the container.

[0145] A preferred embodiment of the present invention can be molded from a semi-flexible thermoplastic such as polypropylene and polyethylene. To reduce manufacturing costs and facilitate injection molding, it can be desirable to taper the walls **130**, **140**, & **160** inward as one moves downward from the open top **180**. An inward taper of 2 degrees on each wall has been employed in several embodiments. On the inner face **161** of the rear wall **160** the faces **169** (FIG. 16, detail) of the pattern can be angled to avoid undercut pulls in the molding process. To assure this, the length of the ledge portion **168** of the pattern can be less than the tangent of the overall wall taper or draft angle times the height of the substantially vertical face **169** between ledges **168**. Since the sine of 2 degrees is approximately 0.035, the ledges **168** would need to be less than 0.028 inches wide if separated by a face height **169** of 0.8 inch ($0.035 \times 0.8 > 0.028$).

[0146] As shown in FIG. 3, the bottom **170** of the container **100** reservoir area **101** can be divided into three areas: a front gently sloping plane **171**; this plane drains rearward into a recessed cylindrical well **172**, which can be sized to fit a paint roller element **65**; and also a small rear flat area **174** which can drain forward into the roller well **172**.

[0147] The bottom **170** (FIG. 12) can be provided with various downwardly extended stiffening webs **173**. The webs **173** can beneficially radiate outward from a central boss point **190** where plastic can be injected into the container mold. A downward tapering flange web **177** can extend down from around the periphery of the bottom **170**. In an embodiment

with legs, cutouts **178** can be provided in the bottom flange **177** for legs **610**, **620**, **630**, **640** to protrude, as shown in FIGS. 13 and 14.

[0148] In a preferred embodiment depicted in FIGS. 1, 9, 11 and 17, the front wall of the container can be formed of two outwardly convex cylindrical surfaces **141** that meet in a near-vertical central indentation **145**. The indentation **145** can provide for additional strength as well as clearance for using the cloth holder **151**. The curvature of the surfaces **141** can help to provide a compact shape for the invention, allowing it to be placed within a five-gallon pail for transportation.

[0149] In a preferred embodiment one of the tool-holding areas **151** (FIG. 2) is configured to retain a cleaning cloth **90**. The form of the cloth holder **151** can be a curved and approximately 'V' shaped hole in a downwardly turned portion **150** of the invention's tool-holding flange **103**. In the lower part of the 'V' notch **153** the sides of the holder can beneficially become parallel or nearly so, to prevent the cloth **90** from working upward and falling out.

[0150] In a preferred embodiment, a portion of the tool-holding flange **103** can have receiving pockets **155** configured to hold a quantity of painter's putty, the putty holding areas can be formed by a pair of shallow recesses **155** located symmetrically on the front flange **150** of the container. For extra strength and rigidity, supporting webs **154** can be provided between the container front wall **140** and the front flange **150**.

[0151] As shown in FIGS. 20 and 21 a magnet **500** can be enclosed within a magnet pocket **550** located in each side wall **130** of the container **100**. Two tapered, downwardly pointing, free-hanging, extensions or ears **530** can be provided proximal to, or within, each magnet pocket **550** to hold the magnet **500** firmly in place after the magnet **500** has been inserted from below along the magnet insertion trough **125** and popped into place within the magnet pocket **550**. The outer wall of the magnet pocket **550** can be formed by a thin plastic extension **120** of the container **100** body; extension **120** can have an outer face **520**. The free-hanging nature of the ears allows them to flex as a magnet **500** is inserted and also flex as an injection molded plastic part ejects from the mold.

[0152] As shown in FIGS. 9, 10, 11 and 12, a lid assembly **200** for the container **100** can be provided in a preferred embodiment. The lid assembly **200** can be equipped with a notch **206** in the back edge **233** of lid element **201**. Edge **233** can be configured to engage the rear side of the open top **180**. The top of the rear wall **160** of the container can have a small downwardly extending notch **106** that aligns with the lid notch **206** when the lid **201** is closed in place. The lid **201** can additionally be provided with two tabs **230** on the back edge **233**. In addition to providing lifting tabs for removing the lid, the tabs **230** can be configured to slip into slots **115** in the horizontal portion **110** of the container rear flange. The tabs **230** can have narrowed areas **231** proximal to where they join to the lid **201**. The narrow areas **231** can snap into place when the snugly-fitting tabs **230** are fully inserted into the slots **115** in the rear flange **110**. The lid assembly **200** is given the identifying number **202** when in its rear stowed position, as shown in FIG. 10. The lid assembly **200** can be configured to engage an angled open top **180** on the container **100**; the angled open top **180** can be fitted with a vertical upwardly extending lip **108** around the periphery of the open top **180**. The lid assembly **200** can engage the container lip **108** in a vertical direction **970**.

[0153] The lid assembly 200 can comprise a substantially vertically downward extending pair of lips: an outer lip 203, and an inner lip 204; these lips can be configured to mate with the upwardly extending lip 108 on the container 100 thus forming a substantially vapor-tight seal between the container 100 and the lid 201.

[0154] The slot 207 between the inner lip 204 and outer lip 203 of the lid 201 may beneficially comprise a wider gap at the base of the slot 208 and have a narrower gap at the entrance to the slot 209; the gap width near the entrance 209 can beneficially provide a snug fit on the container flange 108.

[0155] The container flange 108 may have parallel and vertical wall sides formed with considerable precision, so as to fit well in the slot 207 of the lid element 201. For a snug fit, the gap at the entrance to the slot 209 can be slightly smaller than the thickness of the container flange 108; 0.002" to 0.005" of interference fit may be found sufficient to assure a snug seal. The gap at the base of the slot may beneficially be wider than the width of the container flange 108 plus twice the thickness of a removable liner 800. With this dimensional form the lid lips 203, 204 can flex and allow said container lip 108 with a liner 800 installed to be inserted all the way into the base 208 of the lid lip slot 207.

[0156] Because of this widening of the gap towards its base 208, the mold surfaces forming the slot 207 may experience an undercut or reverse draft situation. To allow the lid 201 element part to eject from the mold it can be beneficial to put compensatingly large amounts of positive draft on the face 210 of the inner lip opposite to the slot face. The outer face 211 of the outer lip 203 can be formed by a second section of mold that joins to the first section containing the lid slot 207 forming plug. As the two mold sections separate, the lid part 201 can stay with the lid slot plug until the outer face 211 of the outer lip has cleared its second mold section. Once clear of this second mold section the outer lip 203 can flex and come off of the lid slot forming plug incorporated in the first mold section.

[0157] The lid element 201 may beneficially be molded from a semi-flexible thermo-plastic such as polyethylene. The plastic used for the lid 201 may beneficially be softer or more flexible than the plastic used to mold the container element 100.

[0158] A typical wall thickness of approximately 0.090 inches can be used in preferred embodiments of both container and lid.

[0159] As shown in FIGS. 9, 10 and 11, the lid assembly 200 can be fitted with a moveable flap 300, said flap 300 being configured to movably cover a notch 206 in the lid when no roller tool shaft 62 is in place. This would maintain a substantially vapor-tight seal when the lid is closed without a roller tool 60 filling the hole formed by the container notch 106 and the lid notch 206. The flap 300 can beneficially be joined to the lid 201 by means of a pivot 321 with an axis 320 as shown by sectional view in FIG. 19. The flap element 300 can alternatively be molded as part of the lid 201 with a flexure attachment between flap 300 and lid 201.

[0160] When pivoted away from the notch 206 as seen in FIG. 10 the protruding portion of the flap 310, which is configured to fill the notch 206, can be provided with a recess 250 in the top of the lid. The recess can have a main semi-circular section 251 and a deeper inverted tee-shaped section 252. These recesses 251, 252 can provide clearance for the flap protrusion 310 to stow without flexing the material of the

flap element 300. The flap element 300 can require some flexing when going from the closed position 301 to completely open position 302.

[0161] The lid 201, when closing, can utilize protruding tabs 225, which have ridges or extensions that can engage contours at 138 along the edge of the hole 137 in the tool flange 103 around the container body 100. This can provide a 'snap into place' function. These protruding tabs 225 can extend downward from the lid 201 when it is closed in the normal resting position of the container. The tabs 225 can engage an outwardly extending ridge 138 formed by the inner edge 138 of the elongated scraper-holding hole 137 in the container's side tool-holding flange 132, 103.

[0162] The lid 201 can be provided with a plurality of tabs extending outward from the edges of the lid. Two of the tabs 230 can be configured to insert into and be held securely in correspondingly shaped holes 115 in a horizontal flange 110 extending rearwards from the main container 100 body. The tabs 230 and slots 115 can beneficially be configured to assure that the lid will lie closely along side of the rear planar wall 160 on the exterior of the container 100 when the lid assembly 200 is in a rearward stowed position 202 as shown in FIG. 10.

[0163] In a preferred embodiment shown in FIG. 4, a paint-spreading grid or screen 70 inserts to fit within a container 100, where the grid 70 can be a substantially planar element, without suspension hooks. The grid 70 can be held securely within the container 100 in a position nearly proximal to a rear planar wall 160 by slots 176 comprised into the interior of the container 100. The spreader grid element 70 can beneficially have rigid beam elements 72 on either side of a porous central element 76

[0164] The beams 72 can be configured to engage the slots 176 in the interior of the container. Slots 176 may beneficially be formed by the following combination: on one edge of the slot by flanges or webs 175 that extend approximately 1/2 inch inwards from the interior faces of the side walls 130 of the container 100; and on the other edge of the slot 176 by the interior surface of radiused corners 128 of the container 100.

[0165] The flanges or webs 175 can beneficially additionally perform the function of preventing jamming or locking together when multiple containers 100 are stacked for storage (without grids 70 in place). To effectively achieve this stack-defining function the flanges 175 can terminate in a substantially horizontal top edge 185 located some distance above the bottom of the container, per preferred example: if the lowest extent 179 of the bottom perimeter flange 177 is located 3.4 inches below the top edge 185 of the web 175, the stacking interval will be 3.4 inches. When stacked, the web flange 175 of a lower container will engage the bottom edge 179 of a container stacked above.

[0166] In the preferred embodiment of FIG. 4, it can be beneficial to provide a slight curvature 74 to the side beams 72 of the grid, with the concave side proximal to the nearby rear wall 160. This feature can help to position the grid more securely and place the top edge 71 of the grid element closer to the nearby rear wall 160. To allow for drainage of paint through the grid, it is beneficial to provide for some gap between the grid and the nearby rear wall 160, approximately 1/16 to 3/16 inch being found sufficient in a preferred embodiment.

[0167] In a preferred embodiment shown in FIGS. 20 & 21, magnets 500 are contained within the side walls 130 of the container 100. The magnets 500 are close to the surface of the container on both the inside 510 and the outside 520 and can

therefore be capable of independently holding magnetically attractable tools **20**, **30** both on the inside **510** and on the outside **520** of the container **100**, near a magnet **500**.

[0168] In a position approximately above a magnet **500** an additional supporting element can be provided in the form of an oblong hole **137** in the side flange **132** running along the side of the open top **180** of the container. The perimeter of this hole **137** can provide additional support for a tool **30** attracted to and held by the magnet **500** to the proximal exterior face **520**.

[0169] In a preferred embodiment, the magnet-equipped side walls **130** of the container can be formed by two substantially parallel elements that are offset laterally **135** from one another by a distance of approximately 0.15 inch. This offset distance can correspond to the approximate thickness of the magnets **500** contained within the walls **130** of the container **100**. The offset **135** may provide for easier molding of magnet-holding pockets **550** within a plastic container part. The offset **135** can also contribute structural integrity to the side walls **130**.

[0170] The magnet pockets **550** can comprise means of securely holding the magnets in position. The form of the magnet holding means can comprise molded plastic pockets **550** within the side walls **130**; the pockets **550** being substantially open on the bottom side. The pockets can be additionally equipped each with two downwardly extending, tapered, semi-flexible plastic 'ears' or extensions **530** that will hold a magnet **500** firmly in place after the magnet **500** is snapped into position from below. The taper of the ears **530** helps to ensure that the ears **530** can separate from the mold section that forms them, by means of bending and flexing of the ears **530**.

[0171] The magnet **500** can be positioned within the side walls **130** such that a relatively thin layer of non-magnetic plastic covers the magnet on both sides **510** and **520**. The thickness of the covering layer may taper and can be in the range of approximately 0.015 inch to 0.030 inch. This is in order to provide sufficient structural integrity while providing for a sufficiently short distance between the magnet **500** and a magnetically attracted tool **20**, **30**. A short distance can assure an adequate holding force between a tool **20**, **30** and a magnet **500**.

[0172] To effectively hold tools, the magnets **500** can be embedded within the side walls **130** of the container **100** in a location approximately one third of the way from the front top lip **108** of the container **100** to the bottom **170**, and approximately one quarter of the way from the front wall **140** to the rear wall **160**.

[0173] In a preferred embodiment bi-functional magnets **500** can be utilized to simultaneously hold a paint brush **20** as well as a scraping tool **30** with the same magnet **500**. In the exemplary preferred embodiment, a magnet **500** is inserted into a close-tolerance receiving structure **550** located in the side wall **130** of the container.

[0174] The offset **135** in the side wall **130** can allow the magnet **500** to have close proximity to both a paintbrush **20** on the inside **510** of the container and a scraper tool **30** on the outside **520**. The offset **135** can make for easier injection molding of the magnet pockets in the container **100**. For example: in this preferred embodiment an approximately 0.025" interior plastic wall between the side of the magnet and the metal band **21** around a paintbrush **20** allows a 0.75 inch diameter magnet **500** to firmly hold a brush **20**. On the outside **520** of the magnet enclosure, an approximately

0.025" thick plastic skirt **120** helps to hold and enclose the magnet, defining the magnetic flux gap spacing for gripping of a scraper tool blade **31**.

[0175] As shown in FIGS. **5** and **6**, a carrying strap **700** can be provided by the present invention. The carrying strap **700** can be formed as a complete loop, said loop form assuring that a user **50** of the invention may securely wear the strap separately, without a container **100** attached, and not have the danger of the strap **760** slipping off the shoulders because of loose ends. The loop form of the strap can enable a user to easily attach and detach the container from the strap element **700** by hooking the strap loop's lower portion **750** under a suitably shaped extension of the container **100** formed by an outward flange **110** joined to a downward flange **111**, both flanges being near the top of the substantially planar rear wall **160** of the container **100**. Additionally the substantially horizontal portion **110** of the rear flange can be provided with indentations **112** in its outer edge **104** near the corner where it meets the downward portion **111** of the flange. These indentations **112** can help to prevent the lower strap section **750** from slipping off the vertical flange **111**, yet allow easy removal of the container **100** from the strap **700** when required. It can be beneficial to provide the strap loop with means of length adjustment **710**, **720**.

[0176] An outward extension **121** of the rear flange **111** can be provided. This extension **121** can form an enclosed area **112** which is capable of holding a strap **700** in place near a rear corner of the container **100**. A narrow portion **124** of the area **112** can be narrow enough to grip a strap **700** as it is inserted into or removed from the enclosed area **112**. The extension **121** can have a semi-flexible nature allowing it to flex as a strap **700** is inserted through the narrow gap **124**. A hole **123** can be provided in the extension **121**. By joining a hole **123** with a hole **119** with a length of cord or wire, the narrow portion **124** is effectively closed, preventing the strap **700** from being able to come out of the enclosed area **112**.

[0177] The carrying strap **700** can comprise a pair of clips **730** or snap hooks, which can be attached to the lower portion of the strap **750** in positions that enable the clips **730** (or snap hooks) to be detachably fastened to appropriate points on the container body, such as a pair of holes **119** in the rear horizontal flange **110**.

[0178] As shown in FIGS. **13** and **14**, a preferred embodiment can be provided with a set of retractable legs. Four legs **610**, **620**, **630** and **640** can be provided, each one pivoting about a point **611**, **621**, **631** and **641** located near each of the four corners of an approximately rectangular or trapezoidal bottom **170** on the container **100**. The pivot axes **615**, **625**, **635** and **645** of the respective legs **610**, **620**, **630** and **640** can beneficially be angled in a manner providing additional stability. By making the pivot axes of the various legs converge together as the axes are extended downward additional stability may be achieved due to this non-parallel angling of the pivot axes. The ends of the legs like **613** that are distal from the container body will be lower when extended, relative to their vertical position when retracted, as shown in FIG. **14** by the arrows **616** and **636**.

[0179] It is desirable to have the portions of the legs like **613** distal from their respective pivot axes flush or slightly above flush with the lowest portion **179** of the downwardly extending flange **177** that partially surrounds the bottom **170** of the container. When the legs are extended, it is desirable to have their distal portions like **613** below flush with the plane defined by the bottom **179** of the surrounding flange **177**. The

lower position of the distal ends **613** of the legs when extended helps to overcome any flex or slop in the leg pivots that might otherwise cause the container **100** to rock or wobble when resting on a flat horizontal surface.

[0180] The angling of the pivot axes may be achieved by angling the lower edge of a circular flange **612** that surrounds a pivot axis **611** on the container **100**. The angle between the pivot axis and the vertical axis **970** of the container **100** can be called **A1**. The vertical axis of the container can be perpendicular to the plane defined by the bottom edge **179** of the container **100**. As shown in FIG. **14**, due to the angling of the axes the length **L1** will be greater than the length **L2**. We have the formula:

$$L1-L2=L3*\text{SINE}(2*A1)$$

which shows the convergence distance of two diagonally opposed axes **615**, **635**. The convergence of the axes causes a lowering of the leg ends **613** when extended. The lowering is shown by the arrows at **616** and **636** in FIG. **14**.

[0181] In a preferred embodiment, a removable liner **800** for the container **100** can be provided. The liner **800** can be formed to fit closely within the container **100**, including fitting closely within any interior slots **176** designed to receive a paint spreading grid **70**. This helps to assure that the grid **70** will still fit in place with a liner **800** installed. FIG. **18** shows the front upper portion of a liner **800** in cross section as the liner fits closely over the container **100** front lips **108** and **143**. The liner **800** can comprise an upper portion that is configured to fit closely over a top lip of the container in such a manner that the liner extends over the top of the lip **810** and then downward by area **820** over the outside surface of the lip **108**, thus allowing the downward extending lips of a sealing lid **203** and **204** to effectively engage the container top lip **108** with or without a liner **800** in place. A preferred embodiment of the present invention can provide a resilient stop unit **850** for a substantially cylindrical tool such as a pencil **11**, pen or the like, as shown in FIGS. **22a** and **22b**. The stop unit **850** can be formed from a somewhat elastic material and can have a flexible hole **853** sized to fit snugly around the cylindrical portion of a tool **854** and an outer extent **870** somewhat larger than the size of the flexible tool hole **853**.

[0182] The tool stop unit **850** can prevent a tool **854** from passing completely through a storage receptacle consisting of a through-hole, like **114**, **116**, or **144**, in a substantially planar support element as may be found on the tool-holding flange **103** of the present container invention.

[0183] The stop collar can have a wavy form with the shape defined in polar coordinates, by the equation as a function of polar angle **P1**:

$$R1=B1+C1*\text{SINE}(N*P1)=\text{interior edge shape}$$

$$R2=B2+C2*\text{SINE}(N*P1)=\text{outline edge shape}$$

[0184] The integer **N** can be varied to provide a varying number of lobes as shown in FIG. **22a**. When **N=2**, the resulting shape **862** can have an oval cross section. When **N=3**, the section **863** can be triangular. When **N=8**, the shape **868** is an eight-pointed star, and so on. The waviness can provide for superior grip on a tool body as compared to a simple round hole.

[0185] A preferred embodiment of the present invention can provide a tape roll holder **900**. The tape roll holder **900** can be configured to hold a roll of tape **40**, such as masking tape, or a plurality of such tape rolls. The tape roll holder can comprise: a lineal flexible element **910** with a first and a

second end (such as a length of nylon cord); a magnetically attractable element **920** (such as a ferrous fob) attached to the first end **911** of said flexible element; means of attaching the second end **912** of said flexible element to the container **100**, such as a loop; and a magnet attached to the container **500**.

[0186] The magnet can be capable of holding the fob **920**, and the magnet can be located at a distance from the second end attachment point **903** that is less than the length of the flexible element **910**.

[0187] To use the tape holder **900**, the fob **912** end of the flexible element **910** can be passed through the central hole **41** of a tape roll **40**, and then the fob **920** can be attached to the magnet **500**. To remove the tape, the fob **920** can be manually detached from the magnet **500** and the tape roll **40** removed from the container **100** assembly.

[0188] Description of the Method of the Present Invention:

[0189] FIG. **24** shows a flow chart depicting a method **1001** for applying and storing surface coating materials, whereby a quantity of surface coating material **1110** may be sequentially applied to various surfaces **1310**, **2010** over a period of time **1810** without having to remove the coating material **1110** from the container **1120** or having to wash the application tools **1210**, thereby saving time and materials, utilizing this method **1001** the handle portions **1510** of application tools **1210** remain clean of coating material **1110** during transport **1700** and storage **1800**.

[0190] Action **1010** comprises the option of installing a liner **800** in a container **1120**.

[0191] Action **1100** comprises putting a quantity of surface coating material **1110** into a container **1120**. A liner **800** can be installed **1010** in said container prior to putting the surface coating material into the container, the liner being of a pre-determined thickness, and the liner being configured to allow substantially normal operation of the lid and permitting formation of a containing assembly **1620** with a liner **800** installed, whereby the liner **800** may be optionally used and removed to facilitate color change or cleanout. The liner **800** can be constructed of thin flexible plastic material of a pre-determined thickness of approximately 0.002" to 0.010", whereby the liner **800** is sufficiently thick to resist puncture in normal use, yet sufficiently thin to fit between the container **1120** and the lid **1610** when the containing assembly **1620** is formed, this allows optional use of a liner **800** with the lid **1610** and the container **1120**.

[0192] Action **1200** comprises transporting the container **1120**, a quantity of surface coating material **20**, **1110** and an application tool **1210** to a location **1220**. The application tool may be selected from the group consisting of: paint roller tools **60**, and paintbrushes **20**, and sponge tools, and faux finish rag tools, and spatulas **30**, and spreading tools. Additionally a plurality of tools can be transported by tool-holding means on the container **1120**. The container **1120** can be transported to the location **1220** by means of a detachable strap assembly **700**, whereby a person **50** may transport materials and equipment with hands free.

[0193] Action **1300** comprises applying some of the surface coating material **1110** to a first surface **1310** at location **1220** with the application tool **1210**. The container can be utilized at location **1220** while the container **1120** is attached to a person **50** by means of a detachable strap assembly **700**, whereby the person may have hands free to use application tools or for other purposes. The container **1120** can be temporarily attached to a supporting element such as: a ladder **66**,

scaffolding, a door, a fence, a knob, a hook, a lanyard; thereby positioning and stabilizing the container **1120**, **100** in a convenient position for use.

[0194] Action **1400** comprises having remaining surface coating material **1410** within the container **1120**

[0195] Action **1500** comprises securing the application tool **1210** to the container **1120**, with the handle section **1510** of the application tool **1210** supported clear of the remaining surface coating material **1410**. Securing the application tool **1210** to the container **1120** can be done by magnetic means.

[0196] Action **1600** comprises fitting a lid **1610** to the container **1120** forming a containing assembly **1620**, thereby enclosing the remaining surface coating material **1410** and the application tool's wet part **1630**, while the application tool's handle section is clear of the remaining surface coating material **1410**.

[0197] The lid **1610** is separate from the application tool **1210**. The lid **1610** can engage the container **1120** by moving downward in a substantially vertical direction, at least one downward lip on the lid **1610** making sliding contact with an upwardly protruding lip on the container **1120**. More specifically, in the preferred embodiment: an inner lip **204** and an outer lip **203** on the lid **201**, **1610** can engage either side of an upwardly protruding lip **108** on the container **100**, **1120**, the upwardly protruding lip **108** can have the form of a generic cylinder, the defining sweeping direction of the generic cylinder being substantially vertical, whereby the lid **200**, **1610** slides off and on along the defining direction and a container part may be ejected from a zero draft section of a mold along the defining axis regardless of the angle formed by the top **180** of the container **100**, **1120**.

[0198] The application tool **1210** can be selected from a group consisting of: paint rolling tools **60** and tools having a substantially cylindrical shaft section; the application tool **1210** having a handle **1510**, an intermediate shaft section of a first predetermined size and a wettable section **1630**;

[0199] Action **1600** can further comprise: placing the application tool **1210** in a notch **206** of a second predetermined size provided in the lid **201**, **1610**, while fitting the lid **201**, **1610**; the first predetermined size and the second predetermined size allowing the intermediate shaft section to fit closely in the slot; and allowing the handle **1510** of the application tool to protrude from the containing assembly while the wettable section of the tool is enclosed within the containing assembly **1620**; the first predetermined size and the second predetermined size resulting in a fit that provides a substantially vapor tight seal for the containing assembly **1620**; whereby the wettable section **1630** of the application tool **1210** is prevented from drying out during storage **1800** and the tool handle **1510** is not in contact with the contained coating material **1410**. The notch **206** can be provided with a moveable cover **300**, whereby the containing assembly **1620** can be sealed against evaporation of contents more effectively when no tool shaft or handle is in the notch **206**. The moveable cover **300** can be captive and pivot about a predetermined axis **320** on the containing assembly. Alternatively, the moveable cover **300** can be captive and attached to the containing assembly **1620** by a flexible element.

[0200] Action **1600** can additionally comprise temporarily attaching the lid **200**, **1610** to the container exterior in a stowage location **202**, the stowage location **202** being different from the position occupied by the lid **200**, **1610** when forming the containing assembly **1620**, whereby the lid **200** when so stowed **202**, is immediately available to seal up the

container and whereby the lid **200**, **1610** is less likely to get lost. Additionally, adding a quantity of thinning liquid to the container **1120** prior to installing the lid **1610** can reduce drying out of the remaining portion of surface coating material **1410** during storage **1800**, as an example, water can be used as a thinning liquid with latex paint.

[0201] Action **1700** comprises transporting the containing assembly **1620** to a suitable storage location **1710**. Transporting the containing assembly to a suitable storage location can additionally comprise placing the containing assembly into the interior of a standard 5 gallon paint pail.

[0202] Action **1800** comprises storing the containing assembly **1620** and contents **1410**, **1630** for a period of time **1810**. If the surface coating material **1410** is latex paint, and the storage location **1710** is free of strong drafts and has room temperature conditions (averaging approximately 40 to 70 degrees Fahrenheit) the period of storage time **1810** between uses of the application tool **1210** can range from a few minutes to a period of approximately six months.

[0203] Action **1900** comprises removing the lid **1610** from the container **1120**.

[0204] Action **2000** comprises applying some of the remaining surface coating material **1410** to a different surface **2010** with the application tool **1210**.

[0205] In the foregoing discussion we make the preferred embodiments exemplary of the possible features and elements of the present invention. It will be clear to one skilled in the art that other embodiments employing the features disclosed herein will also fall within the scope of the present invention

What is claimed is:

1. An improved method for applying and storing surface coating materials comprising:

- (a) putting a first portion of surface coating material into a container
- (b) transporting said container, a quantity of surface coating material and a first application tool to a first location, said first application tool having a handle section and a wettable part
- (c) wetting said wettable part of said first application tool with surface coating material and applying said surface coating material to a first surface proximal to said first location with said first application tool
- (d) having a remaining portion of said surface coating material within said container
- (e) securing said first application tool by securing means provided on said transportable container, said securing means permitting said handle section of said first application tool to be supported clear of said remaining portion of said surface coating material when said containing assembly rests in a normal upright position
- (f) fitting a lid to said container forming a containing assembly, said containing assembly enclosing said remaining portion of said surface coating material and said wettable part of said first application tool, said handle section of said first application tool being clear of said remaining portion of the surface coating material; said lid and said first application tool being distinct from each other
- (g) transporting said containing assembly to a suitable storage location
- (h) storing said containing assembly and contents for a period of time
- (i) removing said lid from said container

- (j) applying a second portion of said remaining portion of said surface coating material to a second surface with said first application tool
- whereby a quantity of surface coating material may be sequentially applied to the surfaces over a period of time without having to remove the coating material from the container or having to wash the application tools, thereby saving time and materials, and whereby the handle portions of tools remain clean of coating material during transport and storage.
2. The method of claim 1 wherein said first application tool is selected from the group consisting of: paint roller tools, and paintbrushes, and sponge tools, and faux finish rag tools, and spatulas, and spreading tools.
3. The method of claim 1 wherein said surface coating material is latex paint, and said suitable storage location is free of strong drafts and has room temperature conditions averaging approximately 40 to 70 degrees fahrenheit, and the period of storage time between uses of said first application tool ranges from a few minutes to a period of approximately six months.
4. The method of claim 1, wherein securing said first application tool to said containing assembly is accomplished by magnetic means.
5. The method of claim 1, wherein said lid engages said container by moving downward in a substantially vertical direction, at least one downward lip on said lid making sliding contact with an upwardly protruding lip on said container.
6. The method of claim 5, wherein an inner lip and an outer lip on said lid engage either side of said upwardly protruding lip on said container, said upwardly protruding lip having the form of a generic cylinder, the defining sweeping direction of said generic cylinder being substantially vertical, whereby the lid slides off and on along the defining direction and a container part may be ejected from a zero draft section of a mold along the defining axis regardless of an angle of the top opening.
7. The method of claim 1 additionally comprising: transporting and using a plurality of additional tools in conjunction with said first application tool, said transporting being accomplished by tool holding means on the container.
8. The method of claim 1, wherein said first application tool is selected from a group consisting of: paint rolling tools and tools having a substantially cylindrical shaft section; said first application tool having a handle, an intermediate shaft section of a first predetermined size and a wettable section; and further comprising: placing said first application tool in a notch of a second predetermined size provided in said lid; said first predetermined size and said second predetermined size allowing said intermediate shaft section to fit closely in said slot; and allowing said handle of said first application tool to protrude from said containing assembly while said wettable section of the tool is enclosed within said containing assembly; the first predetermined size and the second predetermined size resulting in a fit providing a substantially vapor tight seal for the containing assembly; whereby said wettable section of the tool is prevented from drying out during storage and the tool handle is not in contact with the contained coating material.
9. The method of claim 8, wherein said notch is provided with a moveable cover, whereby the containing assembly can be sealed against evaporation of contents more effectively when no tool shaft or handle is in the notch.
10. The method of claim 9, wherein said moveable cover is captive and pivots about a predetermined axis on said containing assembly.
11. The method of claim 9, wherein said moveable cover is captive and is attached to said containing assembly by a flexible element.
12. The method of claim 1 additionally comprising temporarily attaching said lid to said container exterior in a stowage location, said stowage location being different from the position occupied by said lid when forming said containing assembly, whereby the lid is immediately available to seal up the container and the lid is less likely to get lost.
13. The method of claim 1 wherein said container is transported to said first location by means of a detachable strap assembly, whereby a person may transport materials and equipment with hands free.
14. The method of claim 1 additionally comprising utilizing said container at said first location while said container is attached to a person by means of a detachable strap assembly, whereby a person may have hands free to use application tools or support themselves.
15. The method of claim 1 additionally comprising temporarily attaching said container to a supporting element selected from the group consisting of: ladders, and scaffolding, and doors, and chairs, and fences, and knobs, and hooks, and lanyards; thereby positioning and stabilizing the container in a convenient position for use.
16. The method of claim 1 additionally comprising installing a liner in said container prior to putting the surface coating material into the container, said liner being of predetermined thickness, said liner being configured to allow substantially normal operation of the lid and permitting formation of a containing assembly with liner installed, whereby the liner may be optionally used and removed to facilitate color change or clean out.
17. The method of claim 16 wherein said liner is constructed of thin flexible plastic material of predetermined thickness, said predetermined thickness of said liner being sufficiently thick to resist puncture in normal use, yet sufficiently thin to fit between said container and said lid when said containing assembly is formed, thereby allowing optional use of a liner with the lid and the container.
18. The method of claim 1 wherein transporting said containing assembly to said suitable storage location additionally comprises placing said containing assembly into the interior of a standard 5 gallon paint pail.
19. The method of claim 1 additionally comprising adding a quantity of thinning liquid to said container prior to installing said lid and forming said containing assembly, whereby said remaining portion of said surface coating material is further protected from drying out, as example, water can be used as a thinning liquid with latex paint.
20. An improved apparatus for applying and storing surface coating materials comprising:
- (a) a transportable container with an open top, said transportable container being capable of holding a quantity of surface coating material and at least one application tool, said application tool having a handle section and a wettable section, said transportable container having an interior and an exterior, and said transportable container having a bottom part providing means of supporting the container and providing stability when said transportable container sits normally on a substantially flat and level surface

- (b) a lid of predetermined shape and size, said lid being configured to fit over said open top of said transportable container
- (c) a containing assembly formed by the joined combination of said container and said lid, said containing assembly being substantially vapor-tight and said containing assembly being configured to prevent the drying out of any enclosed surface coating material when the assembly is stored in a suitable location for a period of time
- (d) a first securing means for supporting said application tool in a manner which allows said wettable section of said application tool to be enclosed within the substantially vapor-tight containing assembly, said first securing means additionally positioning said handle section of said first application tool such that said handle section is clear of any surface coating material that is within said containing assembly when the assembly is sitting normally
- (e) transporting means providing for convenient movement of the container from location to location by a person whereby surface coating material may be efficiently stored and applied to diverse surfaces over a period of time without having to remove the coating material from the container or having to wash application tools, thereby saving time and materials.

21. The apparatus of claim 20 wherein said open top is inclined to the horizontal at an angle of up to approximately 45 degrees, whereby easier access is provided to the surface coating material inside.

22. The apparatus of claim 20 wherein said first securing means are magnetic means of temporarily attaching said application tool to said containing assembly.

23. The apparatus of claim 22 wherein said magnetic means comprise an individual magnetic element, said individual magnetic element being configured and placed in a region where magnetically attractable objects may be held on both said interior of the container and said exterior of the container, whereby wet paintbrushes may be held inside the container and dry scraping tools on the outside by the same magnet at the same time.

24. The apparatus of claim 23 additionally comprising a lineal flexible element terminating in a magnetically attractable section at a first end, and being attached to said transportable container at a second end; said magnetically attractable section being detachably attachable to said individual magnetic element, said lineal flexible element having some slack when said magnetically attractable end is attached to the magnet, whereby a roll of tape may be transported by putting the attractable end of the lineal element through the roll and attaching the end to the magnet.

25. The apparatus of claim 20 wherein said application tool has a handle section, an intermediate shaft section and a wettable section;

and the apparatus additionally comprising a notch of a predetermined size provided in said lid; the predetermined size being suitable for allowing through passage of the shaft section of said application tool and providing a substantially vapor tight seal therewith, whereby said wettable section of said application tool can be enclosed within said containing assembly and protected from drying out while said handle section of said application tool is exterior to said containing assembly.

26. The apparatus of claim 25 additionally comprising a moveable cover for said notch, said moveable cover being capable of blocking said slot in said lid when no tool handle is therein, said moveable cover providing a substantially vapor tight sealing of the containing assembly, whereby surface coating material may be stored inside said containing assembly and be protected from drying out for periods of time when no tool handle is occupying the notch.

27. The apparatus of claim 26, wherein said moveable cover is captive and pivots about a predetermined axis.

28. The apparatus of claim 26, wherein said moveable cover is captive and is attached to said containing assembly by a flexible element.

29. The apparatus of claim 20 wherein additionally said lid is configured to temporarily attach to said exterior of said transportable container in a stowage location, said stowage location being different from the position occupied by said lid when forming said containing assembly, whereby the lid can be easily kept with the container and is immediately available to seal up the container, also whereby the lid is less likely to get misplaced or lost.

30. The apparatus of claim 29 wherein said lid has extensions configured to fit within receiving elements on the exterior of said transportable container when said lid is installed in said stowage location.

31. The apparatus of claim 20 additionally comprising a detachable strap assembly configured to temporarily attach said container to a person, allowing the person to carry said transportable container without gripping it in their hands, whereby the person may have hands free to use application tools, support themselves, or perform other actions.

32. The apparatus of claim 31 wherein said strap assembly adjustably engages a part of a person selected from the list containing: neck, and shoulders, and waist, and torso, whereby depending on the nature of the job the container may be attached to said person in a variety of different ways.

33. The apparatus of claim 20 additionally comprising means of temporarily attaching said transportable container to a supporting element selected from the group consisting of: ladders, and scaffolding, and doors, and fences, and knobs, and hooks, and lanyards; thereby allowing the container to be positioned and stabilized in a convenient position when in use.

34. The apparatus of claim 33 wherein said means of temporarily attaching said transportable container to a supporting element comprises a mechanism selected from the group consisting of: hooks, and clips, and flange extensions of predetermined shape.

35. The apparatus of claim 20 additionally comprising a liner installed in said container prior to putting the surface coating material into the container, said liner being of predetermined thickness, said liner being configured to allow substantially normal operation of the lid and permitting formation of a containing assembly with liner installed, whereby the liner may be optionally used and removed to facilitate color change or clean out.

36. The apparatus of claim 35 wherein said liner is constructed of thin flexible plastic material, said predetermined thickness of said liner being sufficiently thick to resist puncture in normal use, yet sufficiently thin to fit between said container and said lid when said containing assembly is formed, thereby allowing optional use of a liner with the lid and the container.

37. The apparatus of claim 20 additionally comprising a grid, said grid being substantially planar; said grid engaging said container and being securely yet removably positioned proximal to a substantially planar area on the interior of the container, and said grid fitting within said containing assembly with application tools in their secured positions, whereby surface coating material can be easily distributed on or removed from application tools using said grid, and the grid can be stored inside said containing assembly along with the wettable sections of application tools and remaining coating material.

38. The apparatus of claim 20 additionally comprising a plurality of extendable legs attached to said bottom part of said transportable container, whereby the container is provided with extra stability when resting on a substantially flat and level surface.

39. The apparatus of claim 38 wherein each of said extendable legs pivots about a separate substantially vertical axis, whereby the legs are readily provided with good structural integrity in the vertical direction and yet pivot and fold up easily in a substantially horizontal plane.

40. The apparatus of claim 20 additionally comprising a plurality of tool receiving extensions around the exterior of said container, whereby tools may be transported and used in conjunction with said transportable container.

41. The apparatus of claim 40 additionally comprising at least one tool stop toroid, said tool stop toroid being constructed of elastic material and of predetermined size and shape, said predetermined size and shape being such that the tool stop securely engages a shaft of a substantially cylindrical tool section, said tool stop being of sufficient size and shape to engage said tool receiving extensions on said transportable container, whereby a tool stop around said cylindrical tool section can prevent the tool from sliding past said tool receiving extensions on the container.

42. The apparatus of claim 20 wherein said application tool is selected from the group consisting of: paint roller tools, and paintbrushes, and sponge tools, and faux finish rag tools, and spatulas, and spreading tools.

43. An improved apparatus for applying and transporting surface coating materials comprising:

- (a) a transportable container with an open top, said transportable container being capable of holding a quantity of surface coating material and at least one application tool,

said application tool having a handle section and a wettable section, said transportable container having an interior and an exterior, and said transportable container having a bottom part providing means of supporting the container and providing stability when said transportable container sits normally on a substantially flat and level surface

- (b) multifunctional magnetic means for supporting said application tool in a manner which provides easy access to said handle section of said first application tool and said manner allowing said wettable section of said application tool to drain back into said interior of said transportable container when the container is sitting normally, multifunctional means additionally providing temporary magnetic securing of magnetically attractable items on said exterior of said container, whereby a wet application tool can be temporarily secured inside the container and a dry article temporarily attached on the outside by the same magnetic means.

- (c) transporting means providing for convenient movement of the container from location to location by a person, whereby multiple tools may be secured by a single magnet during transport and between uses.

44. The apparatus of claim 43 wherein a wall section forms part of said transportable container, and said multifunctional magnet means comprise at least one magnet incorporated into said wall section of said transportable container, said magnet being positioned in said wall section so that magnetically attractable objects may come in close proximity to said magnet without being impeded by other material in said wall section, whereby getting closer to the magnet provides stronger magnetic attraction for the tool or other item.

45. The apparatus of claim 42 additionally comprising a removable lid, said removable lid providing a substantially vapor tight seal when installed;

and said multifunctional magnetic means allowing said handle section of said tool to be enclosed within the container by the installed lid, and said handle section of said application tool being supported clear of said quantity of coating material whereby left over paint and a wet tool may be sealed up and stored in the container without washing the tool or container.

* * * * *