



US 20180097565A1

(19) **United States**

(12) **Patent Application Publication** (10) **Pub. No.: US 2018/0097565 A1**
Parekh et al. (43) **Pub. Date: Apr. 5, 2018**

(54) **DATA COMMUNICATIONS CABLE WITH WIRELINE CAPACITANCE COMPENSATION**

(52) **U.S. Cl.**
CPC **H04B 10/25** (2013.01); **G02B 6/4277** (2013.01); **G02B 6/4246** (2013.01); **G09G 2370/045** (2013.01); **G09G 2370/18** (2013.01); **G09G 2370/10** (2013.01); **G09G 5/006** (2013.01); **G02B 6/4293** (2013.01)

(71) Applicant: **Cosemi Technologies, Inc.**, Irvine, CA (US)

(72) Inventors: **Devang Parekh**, Sunnyvale, CA (US); **Nguyen X. Nguyen**, Irvine, CA (US); **Chien-Yu Kuo**, Irvine, CA (US)

(21) Appl. No.: **15/800,335**

(22) Filed: **Nov. 1, 2017**

Related U.S. Application Data

(63) Continuation of application No. 15/186,658, filed on Jun. 20, 2016, now Pat. No. 9,813,153, which is a continuation of application No. 14/322,683, filed on Jul. 2, 2014, now Pat. No. 9,397,750.

(60) Provisional application No. 61/842,890, filed on Jul. 3, 2013, provisional application No. 61/982,727, filed on Apr. 22, 2014.

Publication Classification

(51) **Int. Cl.**
H04B 10/25 (2006.01)
G02B 6/42 (2006.01)
G09G 5/00 (2006.01)

(57) **ABSTRACT**

A communications cable is disclosed. The cable includes a first circuit configured to receive electrical data signals from a data source via an input connector, and convert the electrical data signals into optical signals for transmission by way of one or more optical fibers. The cable includes a second circuit configured to convert the optical signals received via the one or more optical fibers back to electrical data signals for providing to a data sink via an output connector. The cable includes a third circuit for applying pre- and post-signal conditioning to bi-directional control data for transmission to and received from the data sink via wires. The cable includes a fourth circuit for applying pre- and post-signal conditioning to bi-directional control data for transmission to and received from the data source via wires. The pre- and post-signal conditioning compensate for capacitance and/or resistance effects on the signals introduced by the wires.

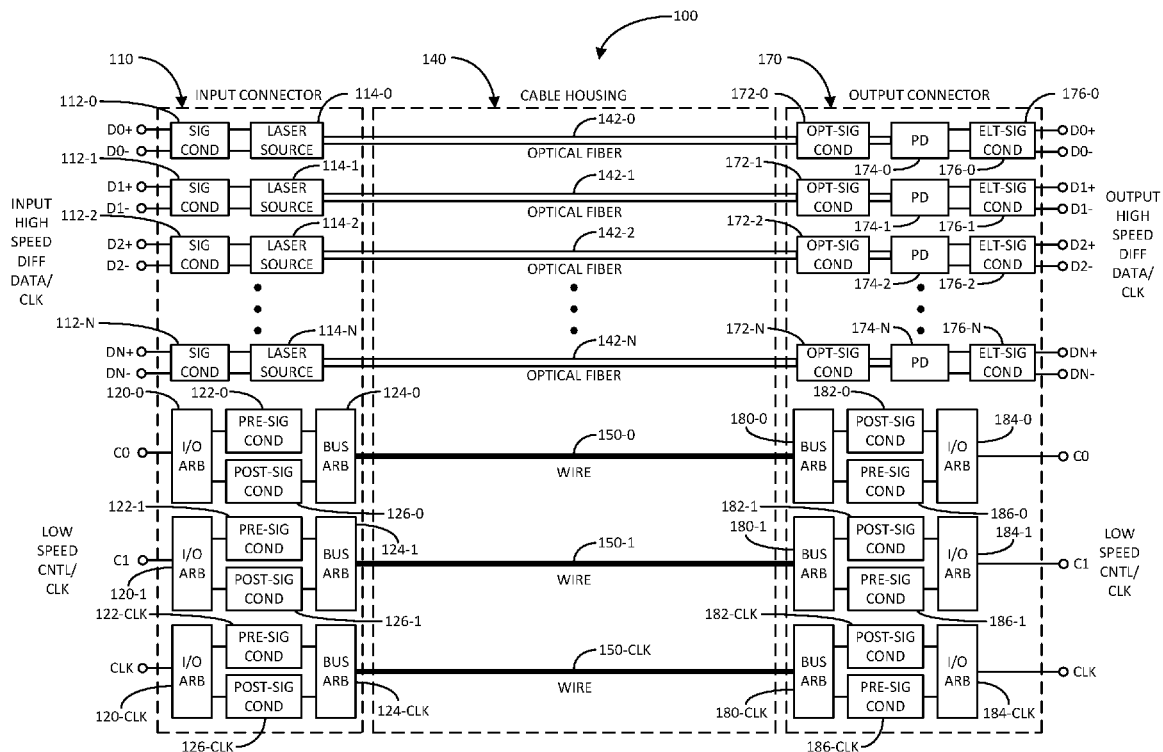

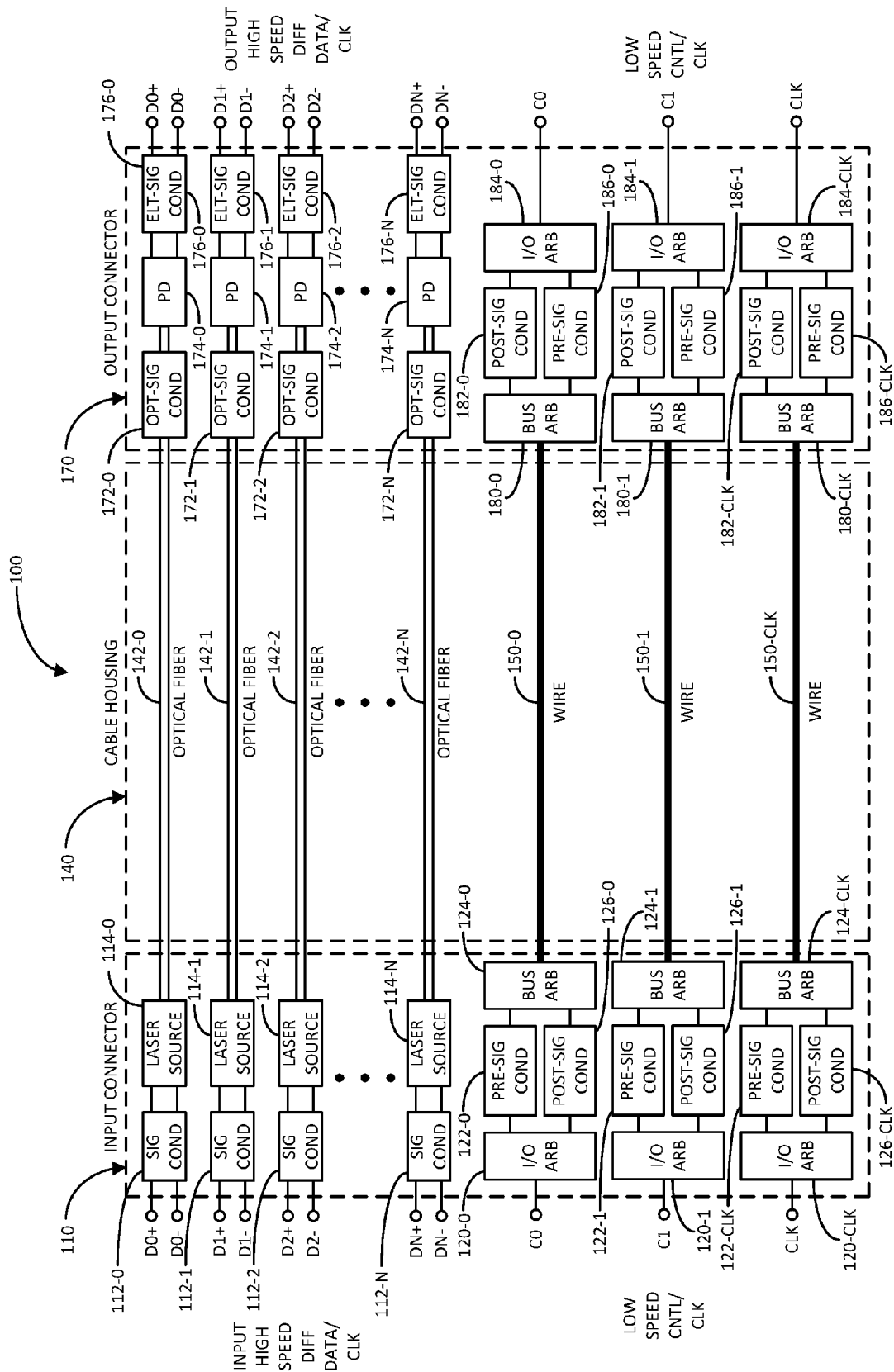

FIG. 1

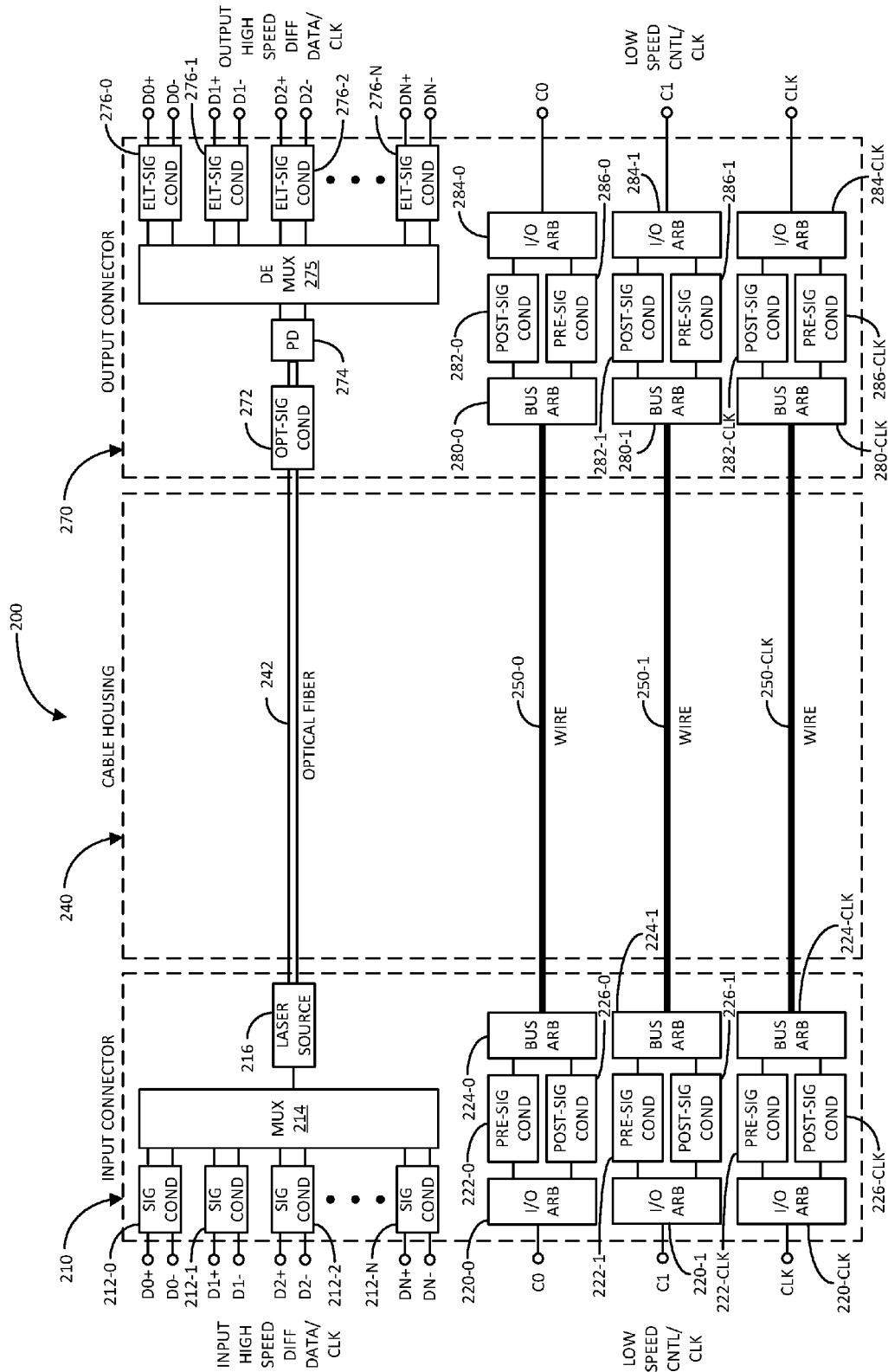

FIG. 2

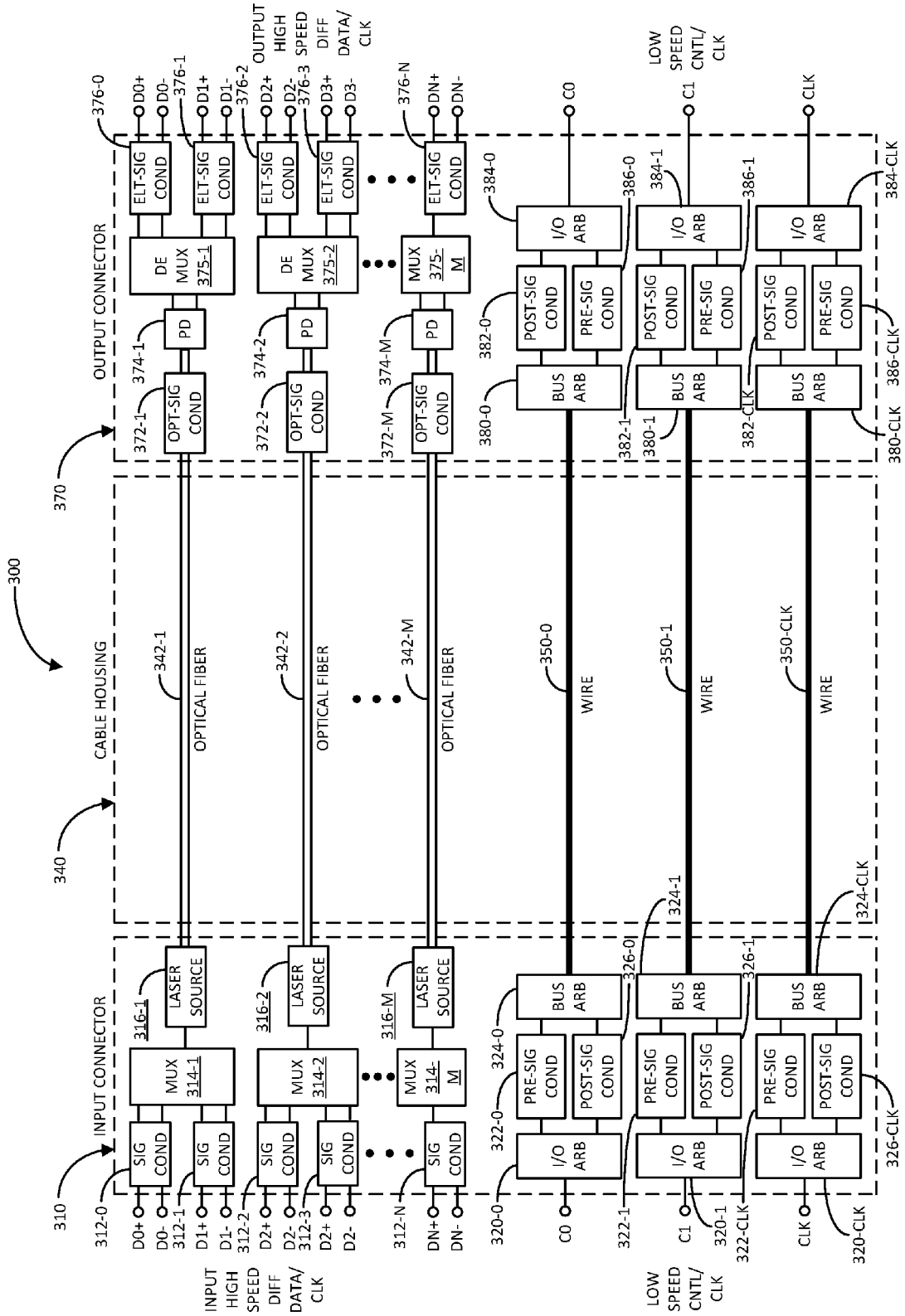

FIG. 3

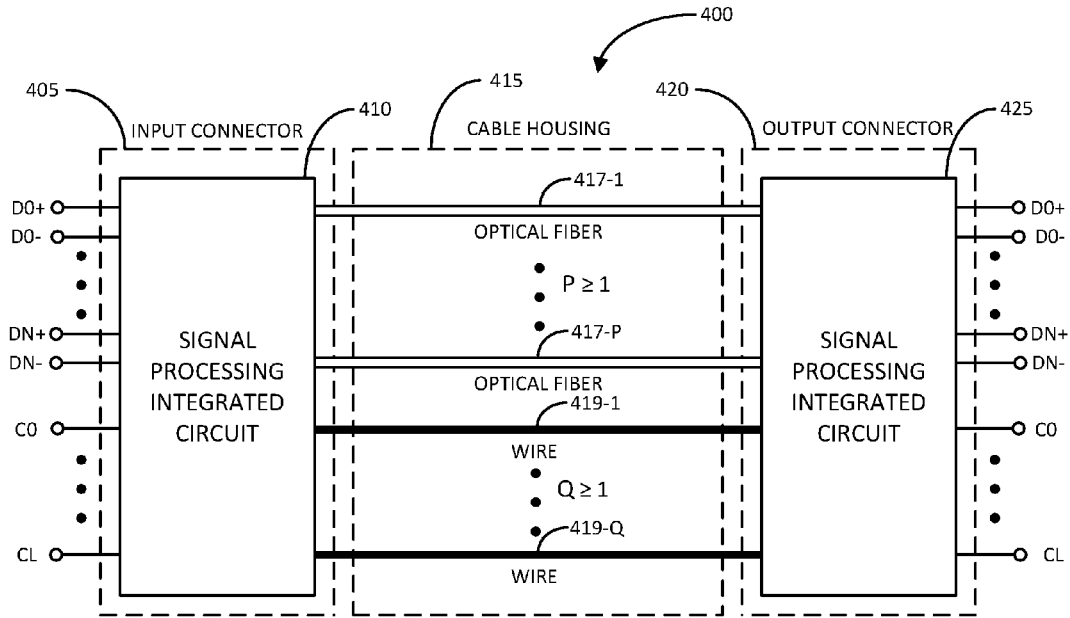

FIG. 4A

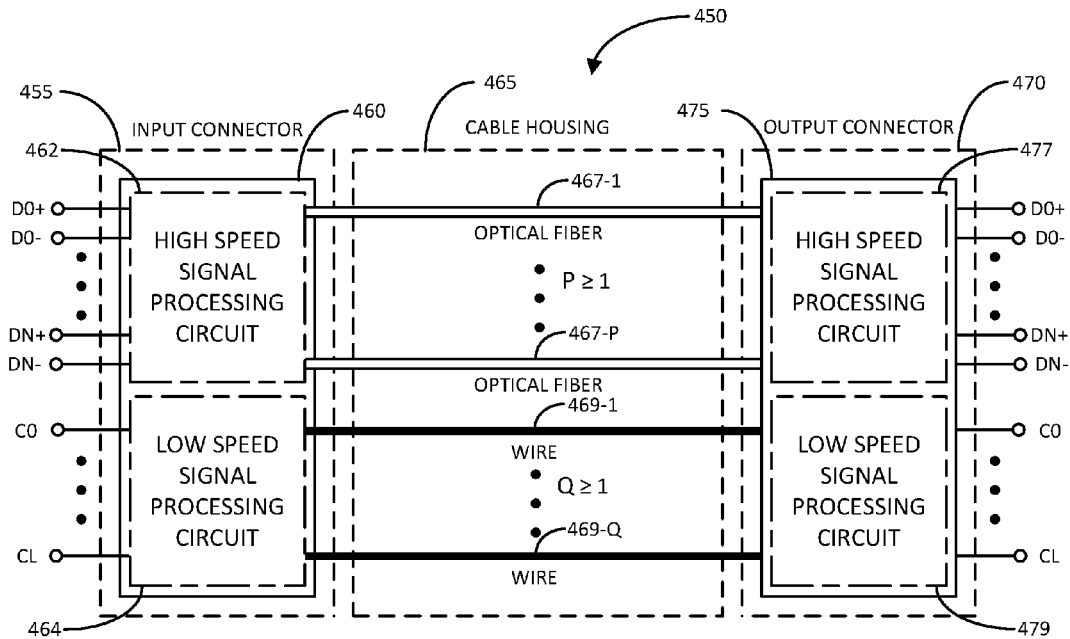

FIG. 4B

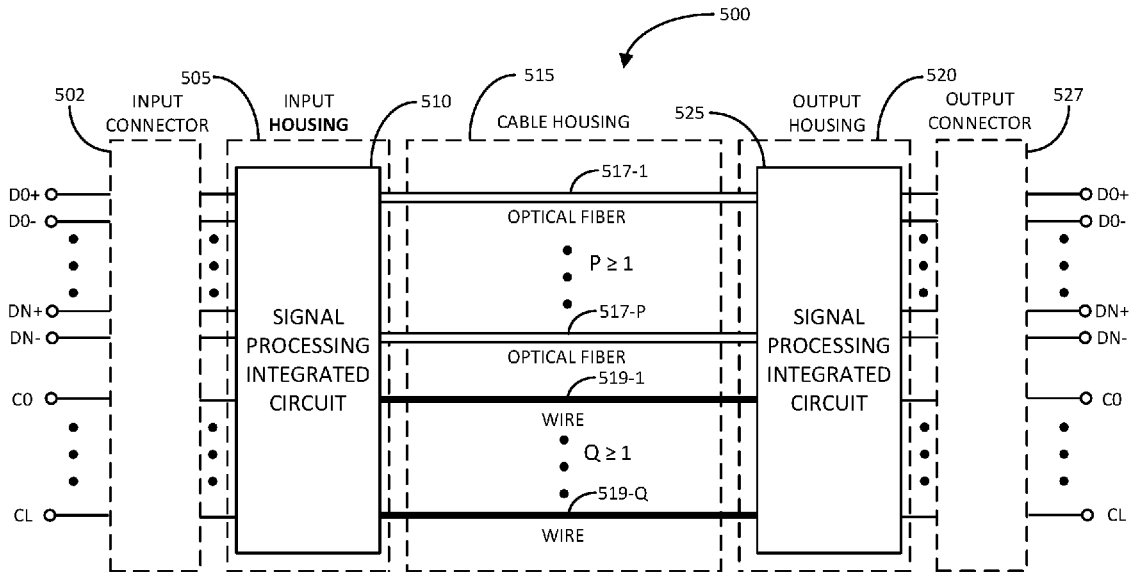

FIG. 5A

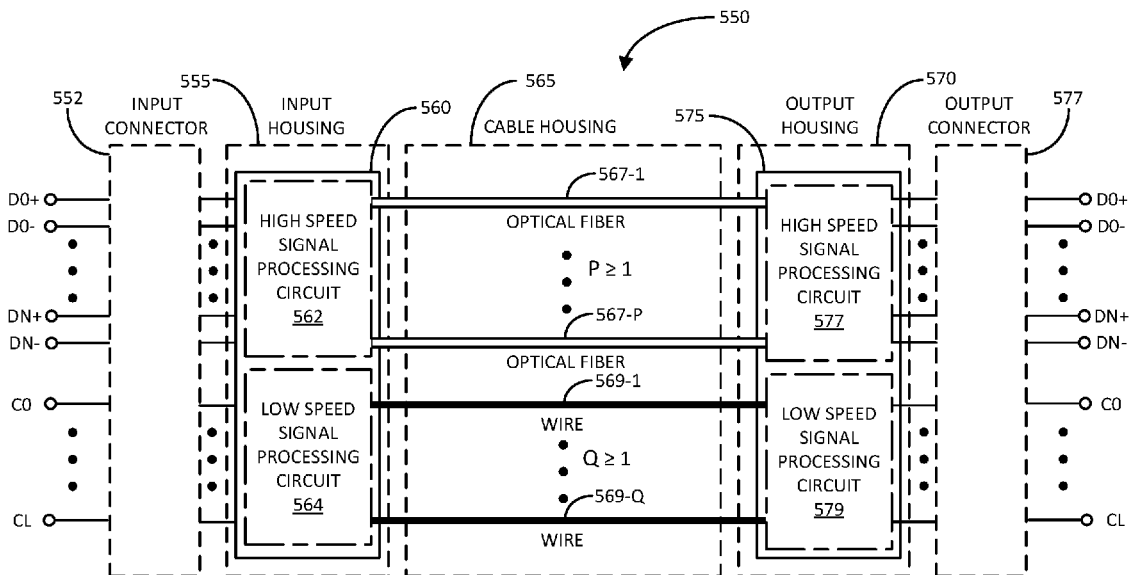

FIG. 5B

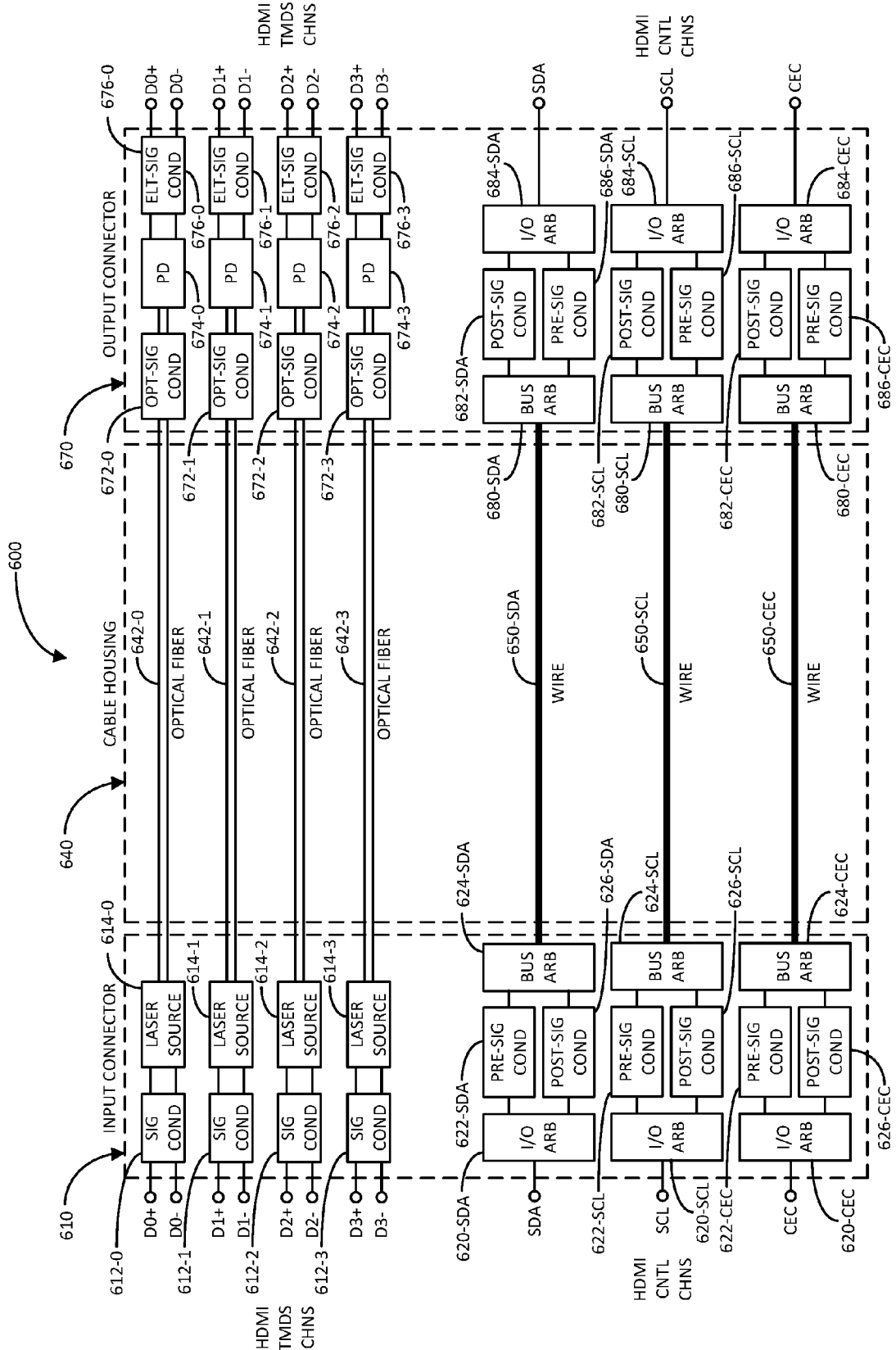

FIG. 6A

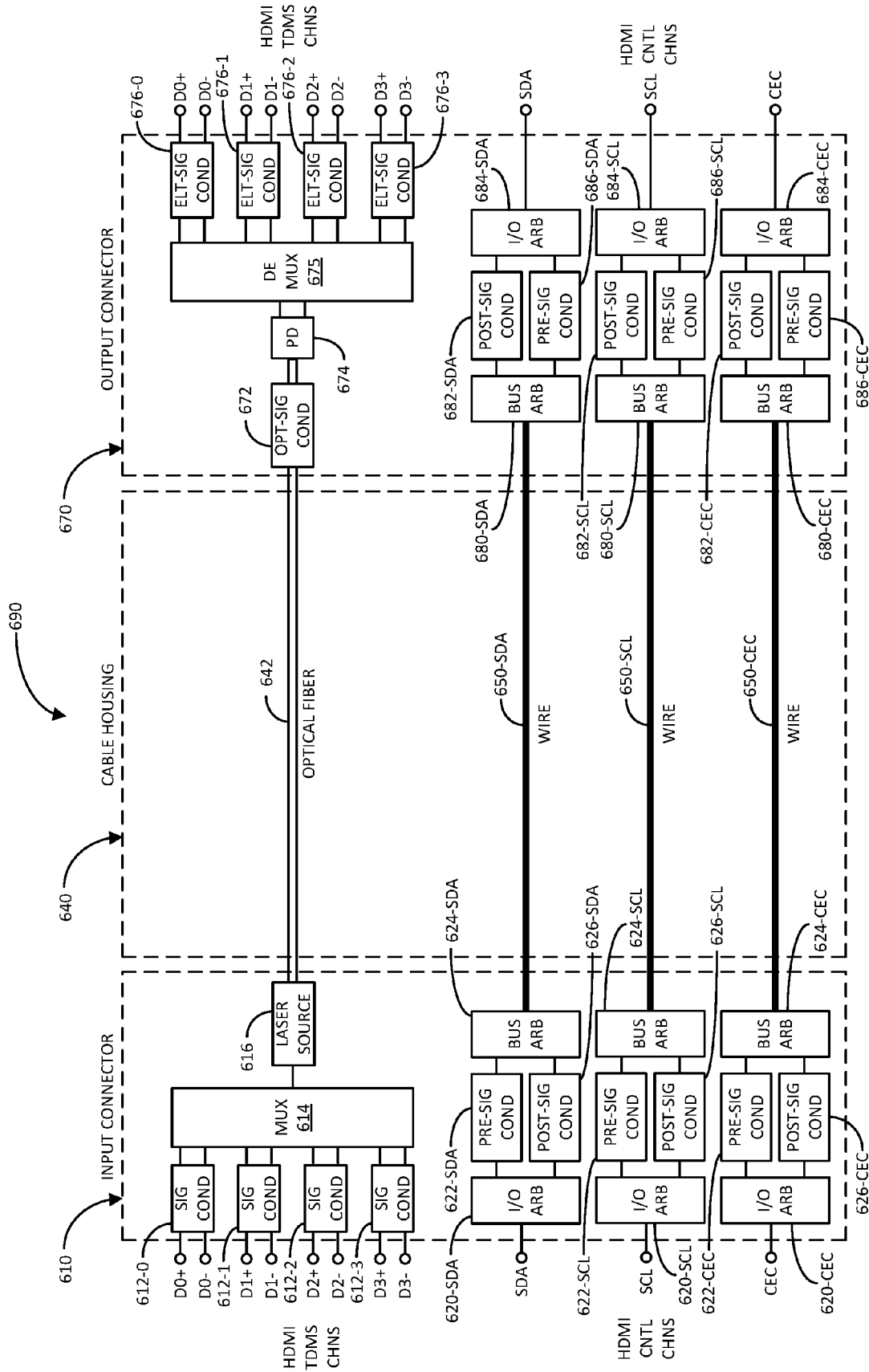

FIG. 6B

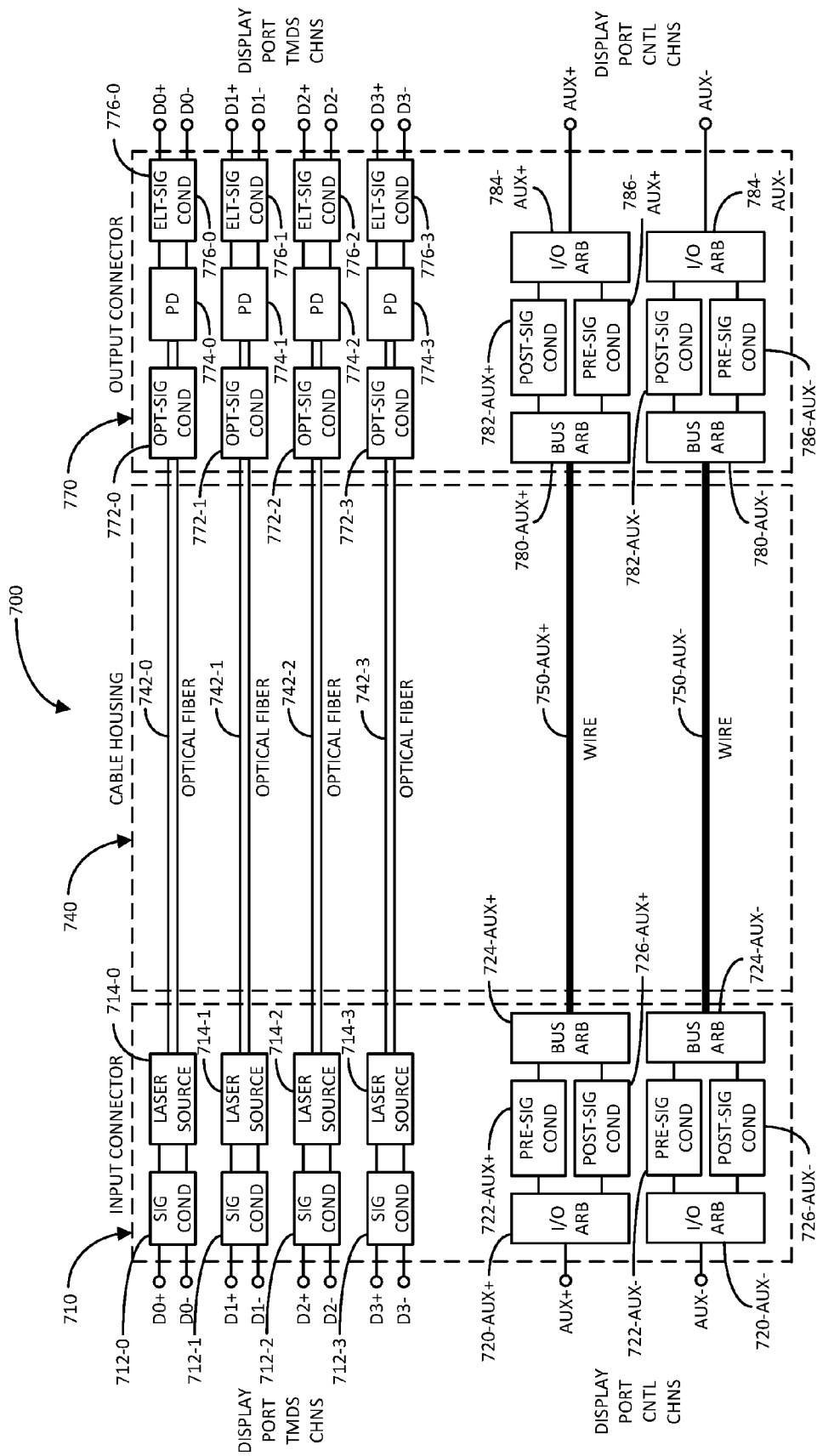

FIG. 7A

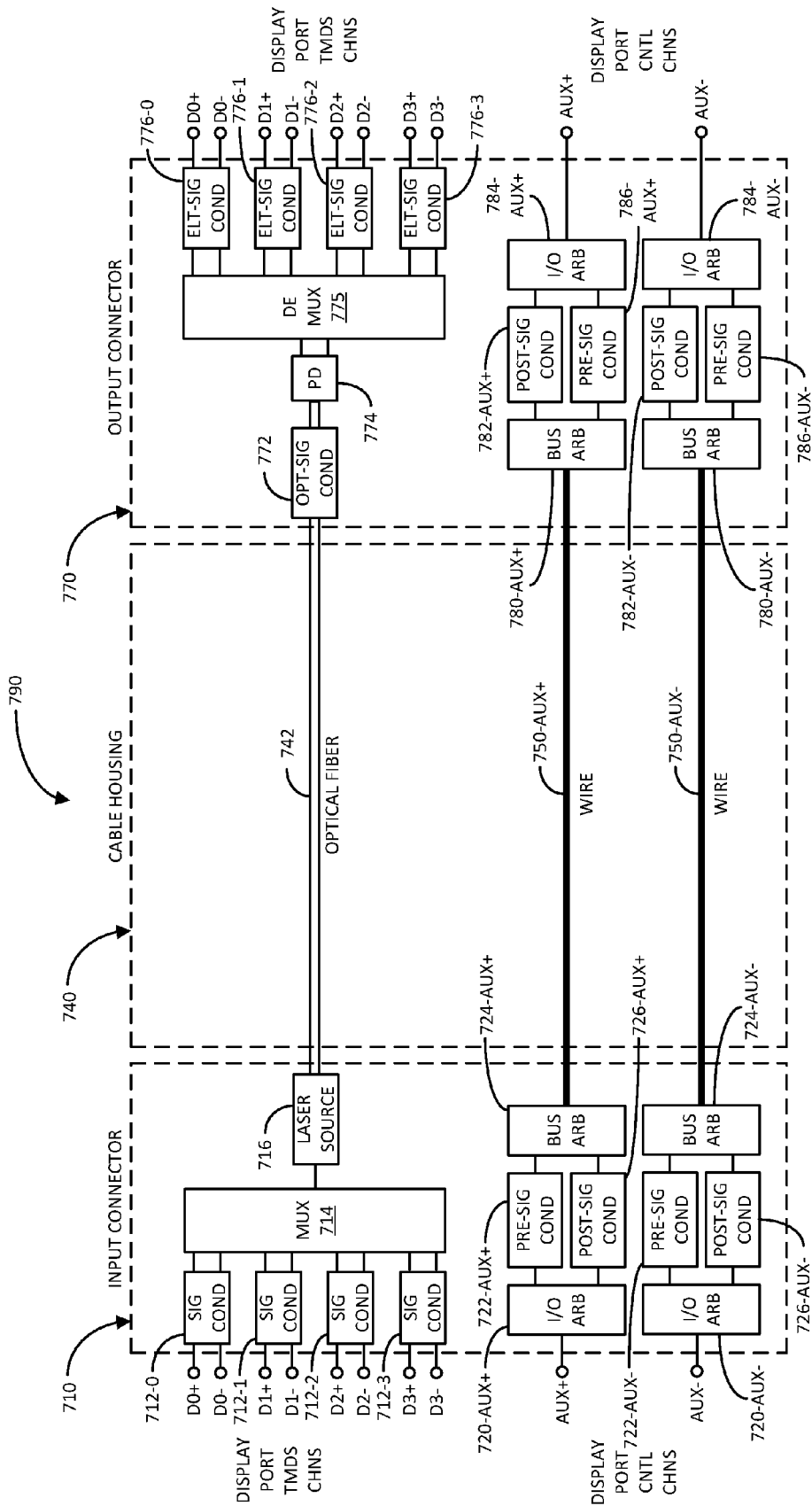

FIG. 7B

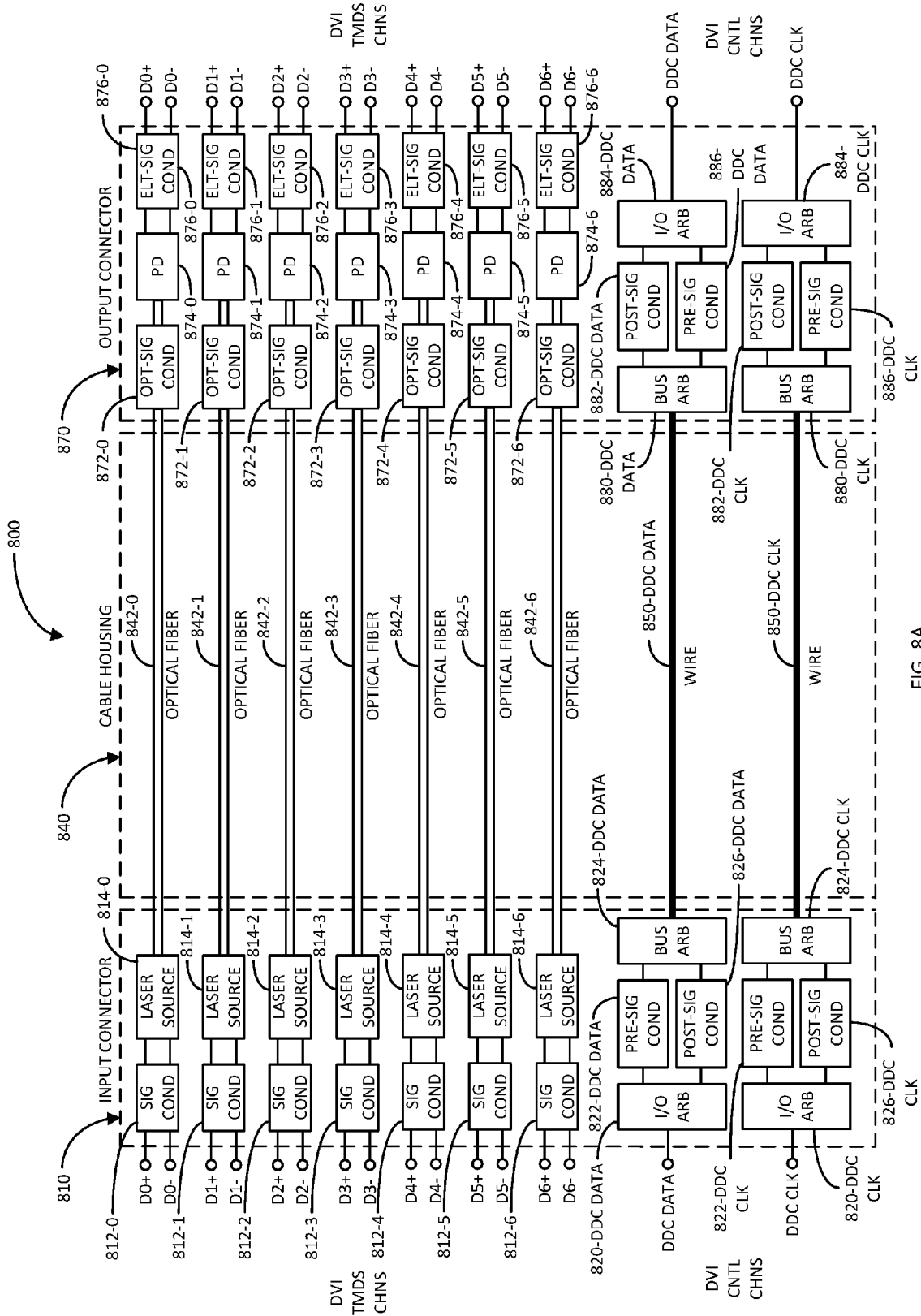

FIG. 8A

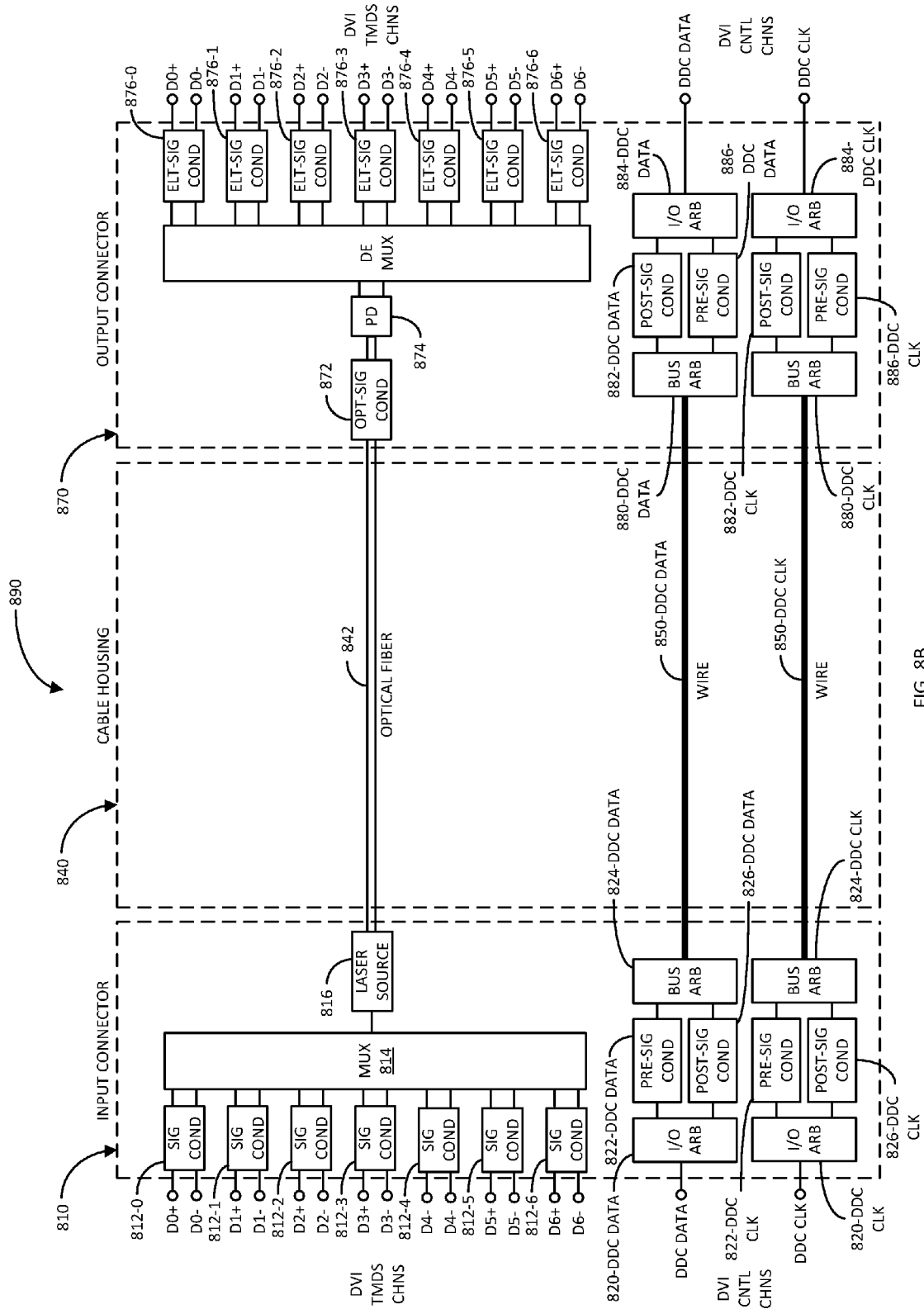

FIG. 8B

DATA COMMUNICATIONS CABLE WITH WIRELINE CAPACITANCE COMPENSATION

CROSS-REFERENCE TO RELATED APPLICATIONS

[0001] This application is a continuation of U.S. patent application Ser. No. 15/186,658, filed on Jun. 20, 2016, which, in turn, is a continuation of U.S. patent application Ser. No. 14/322,683, filed on Jul. 2, 2014, now U.S. Pat. No. 9,397,750, which, in turn, claims the benefit of the filing dates of Provisional Application Ser. No. 61/842,890, filed on Jul. 3, 2013, and Provisional Application Ser. No. 61/982,727, filed on Apr. 22, 2014, all of which are incorporated herein by reference.

FIELD

[0002] This disclosure relates generally to data communications cables, and in particular, to a hybrid electrical-optical data communications cable with wireline capacitance compensation.

BACKGROUND

[0003] Multimedia data, such as audio and video data, are typically communicated from a source of multimedia data (e.g., a digital video recorder (DVR), optical disc player, multimedia distribution facility, etc.) to a sink for the multimedia data (e.g., a television, DVR, audio processing unit, etc.). Generally, data communications cables are employed to route the multimedia data and associated control signals from a source to a sink. Typically, such cables are compliant with one or more data transmission protocols, such as High-Definition Multimedia Interface (HDMI), DisplayPort, and Digital Visual Interface (DVI).

[0004] In the past, these data communications cables have been traditionally implemented with exclusively electrical wires. There are several drawbacks with the conventional cables. Generally, the length of the cables is limited to relatively short distances due to the capacitance and resistive loading associated with the electrical wires. Such capacitance and resistive loading have a greater adverse effect on the relatively high speed multimedia data than on the relatively low speed control data. In this regards, the capacitance of the wires generally limit the bandwidth and data rates of the multimedia data. Further, the high speed multimedia data are more susceptible to electromagnetic interference when the data are transmitted over electrical wires. Additionally, the use of electrical wires, in particular with relatively long length cables, causes the cables to be undesirably heavy for handling, transportation, installation, and use.

[0005] Thus, there is a need, among other needs, for an improved lighter-weight data communications cable for transmitting high speed multimedia data and low speed control data with greater distances, less signal loss and corruption, and reduced electromagnetic interference.

SUMMARY

[0006] An aspect of the disclosure relates to a communications cable comprising an input connector configured for connection to a data source, such as an HDMI-, DisplayPort-, or DVI-compliant data source. The communications cable also comprises an output connector configured for connection to a data sink, such as an HDMI-, DisplayPort-,

or DVI-compliant data sink. Additionally, in one embodiment, the communications cable comprises a plurality of optical fibers and wires coupled to the input and output connectors, respectively.

[0007] The input connector is configured to receive a first set of electrical data signals from the data source. Examples of the first set of electrical signals are multimedia (e.g., audio/video and associated clock) TMDS differential signals generated by an HDMI-, DisplayPort-, or DVI-compliant data source. The input connector is also configured to receive a second set of electrical data signals from the data source. Examples of the second set of electrical signals include SDA, SCL, and CEC control data signals generated by an HDMI-compliant data source, AUX+ and AUX- control data signals generated by a DisplayPort-compliant source, and DDC DATA and DDC CLOCK control data signals generated by a DVI source.

[0008] The input connector is further configured to provide a third set of electrical data signals to the data source, the third set of electrical signals being received from the data sink by way of the output connector and wires, respectively. Examples of the third set of electrical signals include the control-related data signals generated by an HDMI-, DisplayPort-, or DVI-compliant data sink.

[0009] The output connector is configured to provide the first set of electrical data signals to the data sink, the first set of electrical data signals being received from the data source by way of the input connector and the optical fibers, respectively. Additionally, the output connector is configured to provide the second set of electrical data signals to the data sink, the second set of electrical data signals being received from the data source by way of the input connector and the wires, respectively. Further, the output connector is configured to receive the third set of electrical data signals from the data sink.

[0010] The communications cable further comprises a first circuit (e.g., proximate or at the input connector) configured to convert the first set of electrical signals into optical signals for transmission to the data sink by way of the optical fibers and output connector, respectively. The communications cable also comprises a second circuit (e.g., proximate or at the output connector) to convert the optical signals substantially back to the first set of electrical signals for providing them to the data sink.

[0011] The communications cable further comprises a third circuit (e.g., proximate or at the input connector) for applying post-signal conditioning to the third set of electrical signals received from the data sink via the output connector and wires, respectively. The post-signal conditioning compensate for adverse effects (e.g., capacitance and/or resistive effects) on the signals introduced by the wires, and may comprise any one or more of the following: amplifying, buffering, and equalizing the third set of electrical signals.

[0012] Similarly, the communications cable further comprises a fourth circuit (e.g., proximate or at the output connector) for applying post-signal conditioning to the second set of electrical signals received from the data source via the input connector and wires, respectively. The post-signal conditioning compensate for adverse effects (e.g., capacitance and/or resistive effects) on the signals introduced by the wires, and may comprise any one or more of the following: amplifying, buffering, and equalizing the third set of electrical signals.

[0013] The third circuit of the communications cable may also apply pre-signal conditioning to the second set of electrical signals prior to transmission to the data sink via the wires and output connector, respectively. The pre-signal conditioning also compensates for adverse effects (e.g., capacitance and/or resistive effects) on the signals to be introduced by the wires, and may comprise any one or more of the following: amplifying and pre-emphasizing the second set of electrical signals.

[0014] Similarly, the fourth circuit of the communications cable may also apply pre-signal conditioning to the third set of electrical signals prior to transmission to the data source via the wires and input connector, respectively. The pre-signal conditioning also compensates for adverse effects (e.g., capacitance and/or resistive effects) on the signals to be introduced by the wires, and may comprise any one or more of the following: amplifying and pre-emphasizing the third set of electrical signals.

[0015] Other embodiments or variants of the aforementioned communications cable are disclosed. Further, other aspects, advantages and novel features of the disclosure will become apparent from the following detailed description of the invention when considered in conjunction with the accompanying drawings.

BRIEF DESCRIPTION OF THE DRAWINGS

[0016] FIG. 1 illustrates a diagram of an exemplary hybrid electrical-optical data communications cable in accordance with an aspect of the disclosure.

[0017] FIG. 2 illustrates a diagram of another exemplary hybrid electrical-optical data communications cable in accordance with another aspect of the disclosure.

[0018] FIG. 3 illustrates a diagram of another exemplary hybrid electrical-optical data communications cable in accordance with another aspect of the disclosure.

[0019] FIGS. 4A-4B illustrate diagrams of yet other exemplary hybrid electrical-optical data communication cables in accordance with another aspect of the disclosure.

[0020] FIGS. 5A-5B illustrate diagrams of still other exemplary hybrid electrical-optical data communication cables in accordance with another aspect of the disclosure.

[0021] FIGS. 6A-6B illustrate diagrams of exemplary hybrid electrical-optical data communications cables used for transmitting HDMI compliant signals in accordance with another aspect of the disclosure.

[0022] FIGS. 7A-7B illustrate diagrams of exemplary hybrid electrical-optical data communications cables used for transmitting DisplayPort compliant signals in accordance with another aspect of the disclosure.

[0023] FIGS. 8A-8B illustrate diagrams of exemplary hybrid electrical-optical data communications cables used for transmitting DVI compliant signals in accordance with another aspect of the disclosure.

DETAILED DESCRIPTION OF THE EXEMPLARY EMBODIMENTS

[0024] FIG. 1 illustrates a diagram of an exemplary hybrid electrical-optical data communications cable **100** in accordance with an aspect of the disclosure. The communications cable **100** comprises an input connector **110**, a cable housing **140**, and an output connector **170**. The input connector **110** is configured to connect with a corresponding connector of a source of high speed data. The high speed data may be

multimedia data, such as audio, video, and associated clock. Examples of sources of high speed data include a digital video recorder (DVR), an optical disc player, a multimedia distribution facility, and others.

[0025] The high speed data are in the form of electrical digital signals. As an example, the high speed data may be configured as transition-minimized differential signaling (TMDS). For instance, the input connector **110** is configured to receive N number of parallel high speed differential signals **D0+/D0-**, **D1+/D1-**, **D2+/D2-** to **DN+/DN-**.

[0026] The source of high speed data may also serve as a source of low speed control data and associated clock, as well as a sink for low speed control data and associated clock. In this regards, the input connector **110** may be configured to receive parallel low speed control data **C0** and **C1** and associated clock **CLK** from the source of high speed data, as well as provide low speed control data **C0** and **C1** and associated clock to the source of high speed data. The low speed data and associated clock may also be configured as electrical digital signals.

[0027] The input connector **110** includes components configured to convert the high speed electrical signals **D0+/D0-**, **D1+/D1-**, **D2+/D2-** to **DN+/DN-** into optical signals for transmission to the output connector **170** by way of optical fibers **142-0** to **142-N**, respectively. In this regards, the input connector **110** comprises signal conditioners **112-0**, **112-1**, **112-2** to **112-N** configured to receive the high speed electrical signals **D0+/D0-**, **D1+/D1-**, **D2+/D2-** to **DN+/DN-**, and generate therefrom suitable voltages for driving laser sources **114-0**, **114-1**, **114-2** to **114-N**, respectively. The laser sources **114-0**, **114-1**, **114-2** to **114-N**, in turn, generate optical signals based on the drive voltages, the optical signals being coupled to the optical fibers **142-0**, **142-1**, **142-2** to **142-N** for transmission to the output connector **170**, respectively.

[0028] The input connector **110** also includes components for configuring the low speed electrical signals **C0**, **C1**, and **CLK** received from the high speed data source for transmission to the output connector **170** by way of electrically-conductive wires **150-0**, **150-1**, and **150-CLK**, respectively. Additionally, the input connector **110** includes components for receiving low speed electrical signals **C0**, **C1**, and **CLK** from the output connector **170** by way of respective wires **150-0**, **150-1**, and **150-CLK**, and providing the low speed electrical signals to the source of high speed data.

[0029] In this regards, the input connector **110** comprises input/output (I/O) arbiters **120-0**, **120-1**, and **120-CLK**, pre-signal conditioners **122-0**, **122-1**, and **122-CLK**, bus arbiters **124-0**, **124-1**, and **124-CLK**, and post-signal conditioners **126-0**, **126-1**, and **126-CLK**. The I/O arbiters **120-0**, **120-1**, and **120-CLK** arbitrate between low speed signals being received from the high speed data source via connector interface (e.g. pins) for **C0**, **C1**, and **CLK**, and low speed signals being transmitted to the high speed data source via the same connector interface for **C0**, **C1**, and **CLK**.

[0030] The pre-signal conditioners **122-0**, **122-1**, and **122-CLK** condition the low speed electrical signals **C0**, **C1**, and **CLK** received from the I/O arbiters **120-0**, **120-1**, and **120-CLK** for transmissions via the wires **150-0**, **150-1**, and **150-CLK**, respectively. Because of the communications cable **100** may be used for transmitting signals for long distances, the wires **150-0**, **150-1**, and **150-CLK** may exhibit high capacitance and resistive loss that may have adverse effects on the low speed electrical signals. Accordingly, the pre-signal conditioners **122-0**, **122-1**, and **122-CLK** apply

pre-conditioning to the low speed electrical signals C0, C1, and CLK to compensate for the adverse effects associated with the high capacitance and resistive loss of the wires 150-0, 150-1, and 150-CLK, respectively. Examples of pre-conditioning may include any one or more of the following: amplifying the signals, and pre-emphasizing the signals (e.g., providing faster transitions (rise or fall times)).

[0031] The bus arbiters 124-0, 124-1, and 124-CLK arbitrate between low speed signals C0, C1, and CLK being transmitted to the output connector 170 by way of the wires 150-0, 150-1, and 150-CLK, and low speed signals C0, C1, and CLK being received from the output connector 170 via the wires 150-0, 150-1, and 150-CLK, respectively.

[0032] The post-signal conditioners 126-0, 126-1, and 126-CLK condition the low speed electrical signals C0, C1, and CLK received from the bus arbiters 124-0, 124-1, and 124-CLK for transmissions to the source of high speed data via the I/O arbiters 120-0, 120-1, and 120-CLK, respectively. Similarly, the post-signal conditioners 126-0, 126-1, and 126-CLK apply post-conditioning to the low speed electrical signals C0, C1, and CLK to compensate for the adverse effects associated with the high capacitance and resistive loss of the wires 150-0, 150-1, and 150-CLK, respectively. Examples of post-conditioning may include any one or more of the following: amplification of the signals to account for the resistive loss of the wires, buffering the signals to account for the capacitive load of the wires, and equalizing the signals to negate the effects of the wire capacitance.

[0033] The cable housing 140 is configured to protectively enclose the optical fibers 142-0 to 142-N and the wires 150-0 to 150-CLK. Accordingly, the cable housing 140 protects the optical fibers and wires against damage due to handling, transportation, installation, environmental effects, and general use of the communications cable 100. The cable housing 140 may be made of suitable resilient or bendable material useful for routing the communications cable 100.

[0034] The output connector 170 includes components configured to convert the optical signals received by way of the optical fibers 140-0 to 142-N back to the high speed electrical signals D0+/D0- to DN+/DN- for providing them to a sink of the high speed data connected to the output connector 170. In this regard, the output connector 170 comprises optical signal conditioners 172-0, 172-1, 172-2 to 172-N to condition the optical signals received by way of the optical fibers 140-0, 140-1, 140-2 to 142-N for efficient coupling to photo detectors 174-0, 174-1, 174-2 to 174-N, respectively. For instance, the optical conditioners 172-0 to 172-N may include lenses and/or other optical components configured to direct substantially all of the optical signals to substantially the most sensitive region of the photo detectors 174-0 to 174-N, respectively. The photo detectors 174-0 to 174-N convert the received optical signals into electrical signals.

[0035] The output connector 170 further includes electrical signal conditioners 176-0, 176-1, 176-2 to 176-N configured to apply signal conditioning to the electrical signals generated by the photo detectors 174-0, 174-1, 174-2 to 174-N, respectively. In general, the signal conditioners 176-0 to 176-N are configured to generate the high speed electrical signals D0+/D0- to DN+/DN- from the electrical signals generated by the photo detectors 174-0 to 174-N, respectively. That is, the high speed electrical signals D0+/D0- to DN+/DN- generated by the signal conditioners

176-0 to 176-N should be substantially the same as the high speed electrical signals D0+/D0- to DN+/DN- received by the input connector 110, or least compliant with an associated signal protocol. In this regard, the signal conditioners 176-0 to 176-N may convert the electrical signals from the photo detectors 174-0 to 174-N into differential signals, such as TMDS. Additionally, the signal conditioners 176-0 to 176-N may amplify and/or filter the signals to bring the signals to appropriate levels and reduce unwanted noise from the signals.

[0036] The output connector 170 also includes components for receiving low speed electrical signals C0, C1, and CLK from the input connector 110 by way of wires 150-0, 150-1, and 150-CLK, and providing the signals C0, C1, and CLK to the sink of the high speed data connected to the output connector 170. Additionally, the output connector 170 includes components for receiving low speed electrical signals C0, C1, and CLK from the sink of the high speed data, and provide the signals to the wires 150-0, 150-1, and 150-CLK for transmission to the input connector 110, and ultimately, to the source of the high speed data connected to the input connector.

[0037] In this regard, the output connector 170 includes components substantially the same or similar to that of input connector 110 for processing the low speed electrical signals. In particular, the output connector 170 comprises bus arbiters 180-0, 180-1, and 180-CLK, post-signal conditioners 182-0, 182-1, and 182-CLK, I/O arbiters 184-0, 184-1, and 184-CLK, and pre-signal conditioners 186-0, 186-1, and 186-CLK.

[0038] The bus arbiters 180-0, 180-1, and 180-CLK arbitrate between low speed data C0, C1, and CLK being received from the input connector 110 by way of wires 150-0, 150-1, and 150-CLK, and low speed data C0, C1, and CLK for transmission to the input connector 110 via the wires 150-0, 150-1, and 150-CLK, respectively. The post-signal conditioners 182-0, 182-1, and 182-CLK condition the low speed electrical signals C0, C1, and CLK received from the bus arbiters 180-0, 180-1, and 180-CLK for transmissions to the sink of high speed data, respectively. The post-signal conditioners 182-0, 182-1, and 182-CLK may perform any one or more of: signal amplification, buffering, and equalization to counter the capacitance and resistive effects on the signals introduced by the wires 150-0, 150-1, and 150-CLK, respectively.

[0039] The I/O arbiters 184-0, 184-1, and 184-CLK arbitrate between low speed data being received from the high speed data sink via connector interface (e.g. pins) for C0, C1, and CLK, and low speed data being transmitted to the high speed data sink via connector interface for C0, C1, and CLK. The pre-signal conditioners 186-0, 186-1, and 186-CLK condition the low speed electrical signals C0, C1, and CLK received from the I/O arbiters 184-0, 184-1, and 184-CLK for transmission to the input connector 110 via wires 150-0, 150-1, and 150-CLK, respectively. The pre-signal conditioners 186-0, 186-1, and 186-CLK may perform any one or more of: signal amplification and pre-emphasizing to counter the capacitance and resistive effects on the signals that may be introduced by the wires 150-0, 150-1, and 150-CLK, respectively.

[0040] In such configuration, the hybrid electrical-optical communications cable 100 is suitable for longer transmission distances. The optical fiber medium of the cable introduces less losses and adverse effects on the high speed

signals than would otherwise be introduced by wireline alternative. Also, the optical fiber medium is capable of greater bandwidth, and thus, higher data rates and more signal channels. Additionally, the use of the optical fiber medium better protects the signals against electromagnetic interference, and allows the cable to be lighter to facilitate handling, transportation, installation, and use. Finally, regarding the low speed signals, the communications cable 100 includes pre- and post-signal conditioners to compensate for capacitance and resistive effects on the signals introduced by the wires. This again allows the communications cable 100 to be used in longer transmission distance applications. The following provide a discussion of examples of variants of communications cable 100.

[0041] FIG. 2 illustrates a diagram of another exemplary hybrid electrical-optical data communications cable 200 in accordance with another aspect of the disclosure. The communications cable 200 is similar to that of communications cable 100, including many of the same or similar elements, as indicated by the same reference numbers, but using a “2” as the most significant digit rather than a “1”. The communications cable 200 differs from communications cable 100 in that it has an input connector comprising a multiplexer for multiplexing high speed electrical data signals onto a single optical fiber, and an output connector comprising a de-multiplexer for de-multiplexing the high speed electrical data signals from the single optical fiber.

[0042] In particular, the optical communications cable 200 comprises an input connector 210 for connecting to a high speed data source, a cable housing 240 for enclosing the various transmission mediums of the cable, and an output connector 270 for connecting to a high speed data sink.

[0043] The input connector 210, in turn, comprises signal conditioners 212-0, 212-1, 212-2 to 212-N for applying signal conditioning to the high speed data D0+/D0-, D1+/D1-, D2+/D2- to DN+/DN- received from the source of high speed data. The input connector 210 further includes a multiplexer 214 to multiplex the conditioned signals from the signal conditioners 212-0 to 212-N. Additionally, the input connector 210 comprises a laser source 216 for generating an optical signal based on the multiplexed signal generated by the multiplexer 214. The optical signal is transmitted to the output connector 270 by way of optical fiber 242 housed in cable housing 240.

[0044] The input connector 210 of communications cable 200 includes substantially the same elements as the input connector 110 of communications cable 100 for processing bi-directional low speed electrical signals C0, C1 and CLK transmitted between the input and output connectors 210 and 270 via wires 250-0, 250-1, and 250-CLK housed in the cable housing 240. For instance, the input connector 210 comprises I/O arbiters 220-0, 220-1, and 220-CLK, pre-signal conditioners 222-0, 222-1, and 222-CLK, bus arbiters 224-0, 224-1, and 224-CLK, and post-signal conditioners 226-0, 226-1, and 226-CLK. The detail discussion of these elements has been previously provided with reference to communications cable 100.

[0045] The output connector 270, in turn, comprises optical signal conditioner 272, photo detector 274, de-multiplexer 275, and electrical signal conditioners 276-0, 276-1, 276-2, and 276-N. The optical signal conditioner 272 receives the optical signal from the optical fiber 242, and conditions the optical signal for efficient detection by the photo detector 274, as discussed with reference to optical

signal conditioners 172-0 to 172-N of communications cable 100. The photo detector 274 generates an electrical signal based on the conditioned optical signal from the optical signal conditioner 272.

[0046] The de-multiplexer 275 de-multiplexes the multiplexed high speed data components from the electrical signal generated by the photo detector 274, and provides the signals to the signal conditioners 276-0 to 276-N, respectively. The signal conditioners 276-0 to 276-N apply the appropriate signal conditioners to generate the respective high speed data D0+/D0- to DN+/DN-, as per signal conditioners 176-0 to 176-N of communications cable 100 previously discussed. That is, the signal conditioners 276-0 to 276-N apply signal conditioning so that the generated high speed data D0+/D0- to DN+/DN- is substantially the same as the high speed data D0+/D0- to DN+/DN- received by the input connector 210, or at least compliant with an associated protocol.

[0047] The output connector 270 of communications cable 200 includes substantially the same elements as the output connector 170 of communications cable 100 for processing bi-directional low speed electrical signals C0, C1 and CLK transmitted between the input and output connectors 210 and 270 via the wires 250-0, 250-1, and 250-CLK. For instance, the output connector 270 comprises bus arbiters 280-0, 280-1, and 280-CLK, post-signal conditioners 282-0, 282-1, and 282-CLK, I/O arbiters 284-0, 284-1, and 284-CLK, and pre-signal conditioners 286-0, 286-1, and 286-CLK. The detail discussion of these elements has been previously provided with reference to communications cable 100.

[0048] FIG. 3 illustrates a diagram of another exemplary hybrid electrical-optical data communications cable in accordance with another aspect of the disclosure. The communications cable 300 is similar to that of communications cable 200 (as well as cable 100), including many of the same or similar elements, as indicated by the same reference numbers, but using a “3” as the most significant digit rather than a “2”. The communications cable 300 differs from communications cable 200 in that it includes an input connector comprising a plurality of multiplexers for multiplexing respective portions of high speed data components onto a plurality of optical fibers, and an output connector comprising a plurality of de-multiplexers for de-multiplexing the respective multiplexed portions of the high speed data components from the optical fibers.

[0049] In particular, the optical communications cable 300 comprises an input connector 310 for connecting to a high speed data source, a cable housing 340 for enclosing the various transmission mediums of the cable 300, and an output connector 370 for connecting to a high speed data sink.

[0050] The input connector 310, in turn, comprises signal conditioners 312-0, 312-1, 312-2, 312-3 to 312-N for applying signal conditioning to the high speed data D0+/D0-, D1+/D1-, D2+/D2-, D3+/D3- to DN+/DN- received from the source of high speed data. The input connector 310 further includes a plurality of multiplexers 314-1, 314-2 to 314-M to multiplex respective portions D0+/D0- and D1+/D1-, D2+/D2-, D3+/D3-, to DN+1+/DN+1- and DN+/DN- of the conditioned signals from the signal conditioners 312-0 to 312-N. Additionally, the input connector 310 comprises a plurality of laser sources 316-1, 316-2, to 316-M for generating respective optical signals based on the multiplexed signals generated by the multiplexer 314-1, 314-2 to 314-M,

respectively. The optical signals are transmitted to the output connector 370 by way of optical fiber 342-1 to 342-M housed in cable housing 340, respectively. Although, in this example, each of the multiplexers 314-1, 314-2 to 314-M multiplexes two sets of differential signals, it shall be understood that any of the multiplexers may multiplex more than two sets of differential signals.

[0051] The input connector 310 of communications cable 300 includes substantially the same elements as the input connector 110 of communications cable 100 for processing bi-directional low speed electrical signals C0, C1 and CLK transmitted between the input and output connectors 310 and 370 via wires 350-0, 350-1, and 350-CLK housed in cable housing 340. For instance, the input connector 310 comprises I/O arbiters 320-0, 320-1, and 320-CLK, pre-signal conditioners 322-0, 322-1, and 322-CLK, bus arbiters 324-0, 324-1, and 324-CLK, and post-signal conditioners 326-0, 326-1, and 326-CLK. The detail discussion of these elements has been previously provided with reference to communications cable 100.

[0052] The output connector 370, in turn, comprises optical signal conditioners 372-1, 372-2, to 372-M, photo detectors 374-1, 374-2, to 374-M, de-multiplexer 375-1, 375-2, to 375-M, and electrical signal conditioners 376-0, 376-1, 376-2, 376-3 to 376-N. The optical signal conditioners 372-1, 372-2, to 372-M receive the optical signals from optical fibers 342-1, 342-2, to 342-M, and conditions the optical signals for efficient detection by the photo detectors 374-1, 374-2, to 374-M, as discussed with reference to optical signal conditioners 172-0 to 172-N of communications cable 100. The photo detectors 374-1, 374-2, to 374-M generate electrical signals based on the conditioned optical signals from the optical signal conditioner 372-1, 372-2, to 372-M, respectively.

[0053] The de-multiplexers 375-1, 375-2, to 375-M de-multiplex the multiplexed high speed data components from the electrical signals generated by the photo detector 374-1, 374-2, to 374-M, and provide the signals to the signal conditioner pairs 376-0 and 376-1, 376-2 and 376-3, to 376-N-1 and 376-N, respectively. The signal conditioners 376-0 to 376-N apply the appropriate signal conditioning to generate the respective high speed data D0+/D0- to DN+/DN-, as per signal conditioners 176-0 to 176-N of communications cable 100 previously discussed. That is, the signal conditioners 376-0 to 376-N apply the signal conditioning so that the generated high speed data D0+/D0- to DN+/DN- is substantially the same as the high speed data D0+/D0- to DN+/DN- received by the input connector 310, or at least compliant with an associated protocol.

[0054] The output connector 370 of communications cable 300 includes substantially the same elements as the output connector 170 of communications cable 100 for processing bi-directional low speed data C0, C1 and CLK transmitted between the input and output connectors 310 and 370 via the wires 350-0, 350-1, and 350-CLK. For instance, the output connector 370 comprises bus arbiters 380-0, 380-1, and 380-CLK, post-signal conditioners 382-0, 382-1, and 382-CLK, I/O arbiters 384-0, 384-1, and 384-CLK, and pre-signal conditioners 386-0, 386-1, and 386-CLK. The detail discussion of these elements has been previously provided with reference to communications cable 100.

[0055] FIG. 4A illustrates a diagram of another exemplary hybrid electrical-optical data communications cable 400 in accordance with another aspect of the disclosure. In sum-

mary, the communications cable 400 includes respective integrated circuits at the input and output connectors for processing both high speed and low speed data. In particular, the communications cable 400 comprises an input connector 405 for connection to a source of high speed data, a cable housing 415 for protectively enclosing transmission mediums of the cable, and an output connector 425 for connection to a sink of the high speed data.

[0056] The input connector 405, in turn, comprises a single integrated circuit 410 for processing the high speed data D0+/D0- to DN+/DN- for transmission to the output connector 420 via one or more optical fibers 417-1 to 417-P, and processing bi-directional low speed data C0 to CL transmitted via one or more wires 417-1 to 417-Q, as discussed with reference to communications cables 100, 200 and 300. Similarly, the output connector 420 comprises a single integrated circuit 425 for processing the high speed data D0+/D0- to DN+/DN- received from the input connector 405 via the one or more optical fibers 417-1 to 417-P, and processing bi-directional low speed data C0 to CL transmitted via one or more wires 417-1 to 417-Q, as discussed with reference to communications cables 100, 200 and 300.

[0057] FIG. 4B illustrates a diagram of another exemplary hybrid electrical-optical data communications cable 450 in accordance with another aspect of the disclosure. In summary, the communications cable 450 includes separate integrated circuits in each of the input and output connectors for processing high speed and low speed data, respectively. In particular, the communications cable 450 comprises an input connector 455 for connection to a source of high speed data, a cable housing 465 for protectively enclosing transmission mediums of the cable, and an output connector 470 for connection to a sink of the high speed data.

[0058] The input connector 455, in turn, comprises an integrated circuit 462 for processing high speed data D0+/D0- to DN+/DN- for transmission to the output connector 470 via one or more optical fibers 467-1 to 467-P, as per the previous embodiments. The input connector 455 further comprises another integrated circuit 464 for processing bi-directional low speed data C0 to CL transmitted between the input and output connectors 455 and 470 via one or more wires 469-1 to 469-Q, as per the previous embodiments. The integrated circuits 462 and 464 may be disposed on a single substrate 460.

[0059] Similarly, the output connector 470 comprises an integrated circuit 477 for processing high speed data D0+/D0- to DN+/DN- received from the input connector 455 via the one or more optical fibers 467-1 to 467-P, as per the previous embodiments. The output connector 470 further comprises another integrated circuit 479 for processing bi-directional low speed data C0 to CL transmitted between the input and output connectors 455 and 470 via the one or more wires 469-1 to 469-Q, as per the previous embodiments. The integrated circuits 477 and 479 may be disposed on a single substrate 475.

[0060] FIG. 5A illustrates a diagram of another exemplary hybrid electrical-optical data communications cable 500 in accordance with another aspect of the disclosure. In summary, the communications cable 500 includes separate housings, apart from input and output connectors, for housing respective integrated circuits for processing both high speed and low speed data. In particular, the communications cable 500 comprises an input connector 502 for connection to a

source of high speed data, an input housing 505 for housing an integrated circuit 510, a cable housing 515 for protectively enclosing transmission mediums of the cable, an output housing 520 for housing another integrated circuit 525, and an output connector 527 for connection to a sink of the high speed data.

[0061] As mentioned, the input housing 505 comprises a single integrated circuit 510 for processing the high speed data D0+/D0- to DN+/DN- for transmission to the output connector 527 via one or more optical fibers 517-1 to 517-P, and processing bi-directional low speed data C0 to CL transmitted between the connectors 502 and 527 via one or more wires 517-1 to 517-Q, per the previous embodiments. Similarly, the output housing 520 comprises a single integrated circuit 525 for processing the high speed data D0+/D0- to DN+/DN- received from the input connector 502 via the one or more optical fibers 517-1 to 517-P, and processing bi-directional low speed data C0 to CL transmitted between the connectors 502 and 527 via one or more wires 519-1 to 519-Q, as per the previous embodiments.

[0062] FIG. 5B illustrates a diagram of another exemplary hybrid electrical-optical data communications cable 550 in accordance with another aspect of the disclosure. In summary, the communications cable 550 includes separate housings, apart from the input and output connectors, for each housing a pair of integrated circuits for processing high speed and low speed data, respectively. In particular, the communications cable 550 comprises an input connector 552 for connection to a source of high speed data, an input housing 555 for housing integrated circuits 562 and 564, a cable housing 565 for protectively enclosing transmission mediums of the cable, an output housing 570 for housing integrated circuits 577 and 579, and an output connector 577 for connection to a sink of the high speed data.

[0063] As mentioned, the input housing 555 comprises integrated circuit 562 for processing high speed data D0+/D0- to DN+/DN- for transmission to the output connector 577 via one or more optical fibers 567-1 to 567-P, as per the previous embodiments. The input housing 555 further comprises another integrated circuit 564 for processing bi-directional low speed data C0 to CL transmitted between the connectors 552 and 577 via one or more wires 569-1 to 569-Q, as per the previous embodiments. The integrated circuits 562 and 564 may be disposed on a single substrate 560.

[0064] Similarly, the output housing 570 comprises an integrated circuit 577 for processing high speed data D0+/D0- to DN+/DN- received from the input connector 552 via the one or more optical fibers 567-1 to 567-P, as per the previous embodiments. The output connector 570 further comprises another integrated circuit 579 for processing bi-directional low speed data C0 to CL transmitted between the connectors 552 and 577 via the one or more wires 569-1 to 569-Q, as per the previous embodiments. The integrated circuits 577 and 579 may be disposed on a single substrate 575.

[0065] FIG. 6A illustrates a diagram of an exemplary hybrid electrical-optical data communications cable 600 configured for transmitting HDMI compliant signals in accordance with another aspect of the disclosure. In summary, the communications cable 600 is configured generally like communications cable 100, but specifically to transmit HDMI compliant signals between an HDMI data source and an HDMI data sink. In particular, the communications cable

600 comprises an input connector 610 for connection to an HDMI data source, a cable housing 640 for protectively enclosing the transmission mediums of the cable, and an output connector 670 for connection to an HDMI data sink.

[0066] The input connector 610 comprises signal conditioners 612-0, 612-1, 612-2, and 612-3 and laser sources 614-0, 614-1, 614-2, and 614-3 for converting HDMI TMDS channel data D0+/D0-, D1+/D1-, D2+/D2-, and D3+/D3- received from the HDMI data source into optical signals for transmission to the output connector 670 by way of optical fibers 642-0, 642-1, 642-2, and 642-3, respectively. The input connector 610 also comprises I/O arbiters 620-SDA, 620-SCL, and 620-CEC, pre-signal conditioners 622-SDA, 622-SCL, and 622-CEC, bus arbiters 624-SDA, 624-SCL, and 624-CEC, and post-signal conditioners 626-SDA, 626-SCL, and 626-CEC for processing bi-directional Serial Data (SDA), Serial Clock (SCL), and Consumer Electronics Control (CEC) signals transmitted between the input and output connectors 610 and 670 via wires 650-SDA, 650-SCL, and 650-CEC, respectively.

[0067] The output connector 670 comprises optical signal conditioners 672-0, 672-1, 672-2, and 672-3, photo detectors 674-0, 674-1, 674-2, and 674-3, and electrical signal conditioners 676-0, 676-1, 676-2, and 676-3 for converting the optical signals received from the input connector 610 via the optical fibers 642-0, 642-1, 642-2, and 642-3 into HDMI TMDS channel data D0+/D0-, D1+/D1-, D2+/D2-, and D3+/D3- for transmission to the HDMI data sink, respectively. The output connector 670 also comprises bus arbiters 680-SDA, 680-SCL, and 680-CEC, post-signal conditioners 682-SDA, 682-SCL, and 682-CEC, I/O arbiters 684-SDA, 684-SCL, and 684-CEC, and pre-signal conditioners 686-SDA, 686-SCL, and 686-CEC for processing bi-directional SDA, SCL, and CEC signals transmitted between the input and output connectors 610 and 670 via wires 650-SDA, 650-SCL, and 650-CEC, respectively.

[0068] FIG. 6B illustrates a diagram of another exemplary hybrid electrical-optical data communications cable 690 configured for transmitting HDMI compliant signals in accordance with another aspect of the disclosure. In summary, the communications cable 690 is configured generally like communications cable 200, but specifically to transmit HDMI compliant signals between an HDMI data source and an HDMI data sink. In particular, the communications cable 690 comprises an input connector 610 for connection to an HDMI data source, a cable housing 640 for protectively enclosing the transmission mediums of the cable, and an output connector 670 for connection to an HDMI data sink.

[0069] The input connector 610 comprises signal conditioners 612-0, 612-1, 612-2, and 612-3, multiplexer 614, and laser source 616 for converting HDMI TMDS channel data D0+/D0-, D1+/D1-, D2+/D2-, and D3+/D3- received from the HDMI data source into a multiplexed optical signal for transmission to the output connector 670 by way of optical fiber 642. The input connector 610 also comprises I/O arbiters 620-SDA, 620-SCL, and 620-CEC, pre-signal conditioners 622-SDA, 622-SCL, and 622-CEC, bus arbiters 624-SDA, 624-SCL, and 624-CEC, and post-signal conditioners 626-SDA, 626-SCL, and 626-CEC for processing bi-directional SDA, SCL, and CEC signals transmitted between the input and output connectors 610 and 670 via wires 650-SDA, 650-SCL, and 650-CEC, respectively.

[0070] The output connector 670 comprises optical signal conditioner 672, photo detector 674, de-multiplexer 675,

and electrical signal conditioners **676-0**, **676-1**, **676-2**, and **676-3** for converting the multiplexed optical signal received from the input connector **670** via the optical fiber **642** into HDMI TMDS channel data **D0+/D0-**, **D1+/D1-**, **D2+/D2-**, and **D3+/D3-** for transmission to the HDMI data sink, respectively. The output connector **670** also comprises bus arbiters **680-SDA**, **680-SCL**, and **680-CEC**, post-signal conditioners **682-SDA**, **682-SCL**, and **682-CEC**, I/O arbiters **684-SDA**, **684-SCL**, and **684-CEC**, and pre-signal conditioners **686-SDA**, **686-SCL**, and **686-CEC** for processing bi-directional SDA, SCL, and CEC signals transmitted between the input and output connectors **610** and **670** via wires **650-SDA**, **650-SCL**, and **650-CEC**, respectively.

[0071] FIG. 7A illustrates a diagram of exemplary hybrid electrical-optical data communications cable **700** configured for transmitting DisplayPort compliant signals in accordance with another aspect of the disclosure. In summary, the communications cable **700** is configured generally like communications cable **100**, but specifically to transmit DisplayPort compliant signals between a DisplayPort data source and a DisplayPort data sink. In particular, the communications cable **700** comprises an input connector **710** for connection to a DisplayPort data source, a cable housing **740** for protectively enclosing the transmission mediums of the cable, and an output connector **770** for connection to a DisplayPort data sink.

[0072] The input connector **710** comprises signal conditioners **712-0**, **712-1**, **712-2**, and **712-3** and laser sources **714-0**, **714-1**, **714-2**, and **714-3** for converting DisplayPort TMDS channel data **D0+/D0-**, **D1+/D1-**, **D2+/D2-**, and **D3+/D3-** received from the DisplayPort data source into optical signals for transmission to the output connector **770** by way of optical fibers **742-0**, **742-1**, **742-2**, and **742-3**, respectively. The input connector **710** also comprises I/O arbiters **720-AUX+** and **720-AUX-**, pre-signal conditioners **722-AUX+** and **722-AUX-**, bus arbiters **724-AUX+** and **724-AUX-**, and post-signal conditioners **726-AUX+** and **726-AUX-** for processing bi-directional signals **AUX+** and **AUX-** transmitted between the input and output connectors **710** and **770** via wires **750-AUX+** and **750-AUX-**, respectively.

[0073] The output connector **770** comprises optical signal conditioners **772-0**, **772-1**, **772-2**, and **772-3**, photo detectors **774-0**, **774-1**, **774-2**, and **774-3**, and electrical signal conditioners **776-0**, **776-1**, **776-2**, and **776-3** for converting the optical signals received from the input connector **710** via the optical fibers **742-0**, **742-1**, **742-2**, and **742-3** into DisplayPort TMDS channel data **D0+/D0-**, **D1+/D1-**, **D2+/D2-**, and **D3+/D3-** for transmission to the DisplayPort data sink, respectively. The output connector **770** also comprises bus arbiters **780-AUX+** and **780-AUX-**, post-signal conditioners **782-AUX+** and **782-AUX-**, I/O arbiters **784-AUX+** and **784-AUX-**, and pre-signal conditioners **786-AUX+** and **786-AUX-** for processing bi-directional **AUX+** and **AUX-** signals transmitted between the input and output connectors **710** and **770** via wires **750-AUX+** and **750-AUX-**, respectively.

[0074] FIG. 7B illustrates a diagram of another exemplary hybrid electrical-optical data communications cable **790** configured for transmitting DisplayPort compliant signals in accordance with another aspect of the disclosure. In summary, the communications cable **790** is configured generally like communications cable **200**, but specifically to transmit DisplayPort compliant signals between a DisplayPort data

source and a DisplayPort data sink. In particular, the communications cable **790** comprises an input connector **710** for connection to a DisplayPort data source, a cable housing **740** for protectively enclosing the transmission mediums of the cable, and an output connector **770** for connection to a DisplayPort data sink.

[0075] The input connector **710** comprises signal conditioners **712-0**, **712-1**, **712-2**, and **712-3**, multiplexer **714**, and laser source **716** for converting DisplayPort TMDS channel data **D0+/D0-**, **D1+/D1-**, **D2+/D2-**, and **D3+/D3-** received from the DisplayPort data source into a multiplexed optical signal for transmission to the output connector **770** by way of optical fiber **742**. The input connector **710** also comprises I/O arbiters **720-AUX+** and **720-AUX-**, pre-signal conditioners **722-AUX+** and **722-AUX-**, bus arbiters **724-AUX+** and **724-AUX-**, and post-signal conditioners **726-AUX+** and **726-AUX-** for processing bi-directional **AUX+** and **AUX-** signals transmitted between the input and output connectors **710** and **770** via wires **750-AUX+** and **750-AUX-**, respectively.

[0076] The output connector **770** comprises optical signal conditioner **772**, photo detector **774**, de-multiplexer **775**, and electrical signal conditioners **776-0**, **776-1**, **776-2**, and **776-3** for converting the multiplexed optical signal received from the input connector **710** via the optical fiber **742** into DisplayPort TMDS channel data **D0+/D0-**, **D1+/D1-**, **D2+/D2-** and **D3+/D3-** for transmission to the DisplayPort data sink, respectively. The output connector **770** also comprises bus arbiters **780-AUX+** and **780-AUX-**, post-signal conditioners **782-AUX+** and **782-AUX-**, I/O arbiters **784-AUX+** and **784-AUX-**, and pre-signal conditioners **786-AUX+** and **786-AUX-** for processing bi-directional signals **AUX+** and **AUX-** transmitted between the input and output connectors **710** and **770** via wires **750-AUX+** and **750-AUX-**, respectively.

[0077] FIG. 8A illustrates a diagram of exemplary hybrid electrical-optical data communications cable **800** configured for transmitting DVI compliant signals in accordance with another aspect of the disclosure. In summary, the communications cable **800** is configured generally like communications cable **100**, but specifically to transmit DVI compliant signals between a DVI data source and a DVI data sink. In particular, the communications cable **800** comprises an input connector **810** for connection to a DVI data source, a cable housing **840** for protectively enclosing the transmission mediums of the cable, and an output connector **870** for connection to a DVI data sink.

[0078] The input connector **810** comprises signal conditioners **812-0**, **812-1**, **812-2**, **812-3**, **812-4**, **812-5**, and **812-6** and laser sources **814-0**, **814-1**, **814-2**, **814-3**, **814-4**, **814-5**, and **814-6** for converting DVI TMDS channel data **D0+/D0-**, **D1+/D1-**, **D2+/D2-**, **D3+/D3-**, **D4+/D4-**, **D5+/D5-**, and **D6+/D6-** received from the DVI data source into optical signals for transmission to the output connector **870** by way of optical fibers **842-0**, **842-1**, **842-2**, **842-3**, **842-4**, **842-5**, and **842-6**, respectively. The input connector **810** also comprises I/O arbiters **820-DDC DATA** and **820-DDC CLK**, pre-signal conditioners **822-DDC DATA** and **822-DDC CLK**, bus arbiters **824-DDC DATA** and **824-DDC CLK**, and post-signal conditioners **826-DDC DATA** and **826-DDC CLK** for processing bi-directional display data channel (DDC DATA) and display data clock (DDC CLK) signals

transmitted between the input and output connectors **810** and **870** via wires **850-DDC DATA** and **850-DDC CLK**, respectively.

[0079] The output connector **870** comprises optical signal conditioners **872-0**, **872-1**, **872-2**, **872-3**, **872-4**, **872-5**, and **872-6**, photo detectors **874-0**, **874-1**, **874-2**, **874-3**, **874-4**, **874-5**, and **874-6**, and electrical signal conditioners **876-0**, **876-1**, **876-2**, **876-3**, **876-4**, **876-5**, and **876-6** for converting the optical signals received from the input connector **810** via the optical fibers **842-0**, **842-1**, **842-2**, **842-4**, **842-5**, and **842-6** into DVI TMDS channel data **D0+/D0-**, **D1+/D1-**, **D2+/D2-**, **D3+/D3-**, **D4+/D4-**, **D5+/D5-**, and **D6+/D6-** for transmission to the DVI data sink, respectively. The output connector **870** also comprises bus arbiters **880-DDC DATA** and **880-DDC CLK**, post-signal conditioners **882-DDC DATA** and **882-DDC CLK**, I/O arbiters **884-DDC DATA** and **884-DDC CLK**, and pre-signal conditioners **886-DDC DATA** and **886-DDC CLK** for processing bi-directional signals **DDC DATA** and **DDC CLK** transmitted between the input and output connectors **810** and **870** via wires **850-DDC DATA** and **850-DDC CLK**, respectively.

[0080] FIG. 8B illustrates a diagram of exemplary hybrid electrical-optical data communications cable **890** configured for transmitting DVI compliant signals in accordance with another aspect of the disclosure. In summary, the communications cable **890** is configured generally like communications cable **200**, but specifically to transmit DVI compliant signals between a DVI data source and a DVI data sink. In particular, the communications cable **890** comprises input connector **810** for connection to a DVI data source, a cable housing **840** for protectively enclosing the transmission mediums of the cable, and an output connector **870** for connection to a DVI data sink.

[0081] The input connector **810** comprises signal conditioners **812-0**, **812-1**, **812-2**, **812-3**, **812-4**, **812-5**, and **812-6**, multiplexer **814**, and laser source **816** for converting DVI TMDS channel data **D0+/D0-**, **D1+/D1-**, **D2+/D2-**, **D3+/D3-**, **D4+/D4-**, **D5+/D5-**, and **D6+/D6-** received from the DVI data source into a multiplexed optical signal for transmission to the output connector **870** by way of optical fiber **842**. The input connector **810** also comprises I/O arbiters **820-DDC DATA** and **820-DDC CLK**, pre-signal conditioners **822-DDC DATA** and **822-DDC CLK**, bus arbiters **824-DDC DATA** and **824-DDC CLK**, and post-signal conditioners **826-DDC DATA** and **826-DDC CLK** for processing bi-directional signals **DDC DATA** and **DDC CLK** transmitted between the input and output connectors **810** and **870** via wires **850-DDC DATA** and **850-DDC CLK**, respectively.

[0082] The output connector **870** comprises optical signal conditioner **872**, photo detector **874**, and electrical signal conditioners **876-0**, **876-1**, **876-2**, **876-3**, **876-4**, **876-5**, and **876-6** for converting the multiplexed optical signal received from the input connector **810** via the optical fiber **842** into DVI TMDS channel data **D0+/D0-**, **D1+/D1-**, **D2+/D2-**, **D3+/D3-**, **D4+/D4-**, **D5+/D5-**, and **D6+/D6-** for transmission to the DVI data sink, respectively. The output connector **870** also comprises bus arbiters **880-DDC DATA** and **880-DDC CLK**, post-signal conditioners **882-DDC DATA** and **882-DDC CLK**, I/O arbiters **884-DDC DATA** and **884-DDC CLK**, and pre-signal conditioners **886-DDC DATA** and **886-DDC CLK** for processing bi-directional signals **DDC DATA** and **DDC CLK** transmitted between the input and output connectors **810** and **870** via wires **850-DDC DATA** and **850-DDC CLK**, respectively.

[0083] While the invention has been described in connection with various embodiments, it will be understood that the invention is capable of further modifications. This application is intended to cover any variations, uses or adaptation of the invention following, in general, the principles of the invention, and including such departures from the present disclosure as come within the known and customary practice within the art to which the invention pertains.

What is claimed is:

1. A communications cable, comprising:

an input connector configured to:

connect to a data source;

receive a first set of electrical data signals from the data source;

receive a second set of electrical data signals from the data source; and

provide a third set of electrical data signals from a data sink to the data source;

an output connector configured to:

connect to the data sink;

provide the first set of electrical data signals to the data sink;

provide the second set of electrical data signals to the data sink; and

receive the third set of electrical data signals from the data sink;

a set of one or more optical fibers coupled to the input and output connectors;

a set of one or more electrical wires coupled to the input and output connectors;

a first circuit situated within the input connector or an input housing, wherein the first circuit is configured to convert the first set of electrical data signals into one or more optical signals for transmission to the output connector by way of the set of one or more optical fibers, respectively;

a second circuit situated within the output connector or an output housing, wherein the second circuit is configured to convert the one or more optical signals received by way of the set of one or more optical fibers back to the first set of electrical data signals, respectively; and

a third circuit situated within the output connector or the output housing, wherein the third circuit is configured to apply a first signal conditioning on the second set of electrical data signals received by way of the set of one or more wires.

2. The communications cable of claim 1, wherein the first signal conditioning comprises equalizing the second set of electrical data signals.

3. The communications cable of claim 1, wherein the first signal conditioning comprises amplifying the second set of electrical data signals.

4. The communications cable of claim 1, wherein the first signal conditioning comprises buffering the second set of electrical data signals.

5. The communications cable of claim 1, wherein the first signal conditioning comprises buffering or amplifying and equalizing the second set of electrical data signals.

6. The communications cable of claim 1, wherein the first signal conditioning comprises buffering, amplifying and equalizing the second set of electrical data signals.

7. The communications cable of claim 1, further comprising a fourth circuit situated within the output connector

or the output housing, wherein the fourth circuit is configured to apply a second signal conditioning on the third set of electrical data signals.

8. The communications cable of claim 7, wherein the second signal conditioning comprises pre-emphasizing the third set of electrical data signals.

9. The communications cable of claim 7, wherein the second signal conditioning comprises amplifying the third set of electrical data signals.

10. The communications cable of claim 7, wherein the second signal conditioning comprises amplifying and pre-emphasizing the third set of electrical data signals.

11. A communications cable, comprising:

an input connector configured to:

- connect to a data source;
- receive a first set of electrical data signals from the data source;
- receive a second set of electrical data signals from the data source; and
- provide a third set of electrical data signals from a data sink to the data source;

an output connector configured to:

- connect to the data sink;
- provide the first set of electrical data signals to the data sink;
- provide the second set of electrical data signals to the data sink; and
- receive the third set of electrical data signals from the data sink;

a set of one or more optical fibers coupled to the input and output connectors;

a set of one or more electrical wires coupled to the input and output connectors;

a first circuit situated within the input connector or an input housing, wherein the first circuit is configured to convert the first set of electrical data signals into one or more optical signals for transmission to the output connector by way of the set of one or more optical fibers, respectively;

a second circuit situated within the output connector or an output housing, wherein the second circuit is configured to convert the one or more optical signals received by way of the set of one or more optical fibers back to the first set of electrical data signals, respectively; and

a third circuit situated within the output connector or the output housing, wherein the third circuit is configured to apply a signal conditioning on the third set of electrical data signals.

12. The communications cable of claim 11, wherein the signal conditioning comprises pre-emphasizing the third set of electrical data signals.

13. The communications cable of claim 11, wherein the signal conditioning comprises amplifying the third set of electrical data signals.

14. The communications cable of claim 11, wherein the signal conditioning comprises amplifying and pre-emphasizing the third set of electrical data signals.

15. A communications cable, comprising:

an input connector configured to:

- connect to a data source;
- receive a first set of electrical data signals from the data source;
- receive a second set of electrical data signals from the data source; and

provide a third set of electrical data signals from a data sink to the data source;

an output connector configured to:

- connect to the data sink;
- provide the first set of electrical data signals to the data sink;
- provide the second set of electrical data signals to the data sink; and
- receive the third set of electrical data signals from the data sink;

a set of one or more optical fibers coupled to the input and output connectors;

a set of one or more electrical wires coupled to the input and output connectors;

a first circuit situated within the input connector or an input housing, wherein the first circuit is configured to convert the first set of electrical data signals into one or more optical signals for transmission to the output connector by way of the set of one or more optical fibers, respectively;

a second circuit situated within the output connector or an output housing, wherein the second circuit is configured to convert the one or more optical signals received by way of the set of one or more optical fibers back to the first set of electrical data signals, respectively; and

a third circuit situated within the input connector or the input housing, wherein the third circuit is configured to apply a first signal conditioning on the third set of electrical data signals received by way of the set of one or more wires.

16. The communications cable of claim 15, wherein the first signal conditioning comprises equalizing the third set of electrical data signals.

17. The communications cable of claim 15, wherein the first signal conditioning comprises amplifying the third set of electrical data signals.

18. The communications cable of claim 15, wherein the first signal conditioning comprises buffering the third set of electrical data signals.

19. The communications cable of claim 15, wherein the first signal conditioning comprises buffering or amplifying and equalizing the third set of electrical data signals.

20. The communications cable of claim 15, wherein the first signal conditioning comprises buffering, amplifying and equalizing the third set of electrical data signals.

21. The communications cable of claim 15, further comprising a fourth circuit situated within the input connector or the input housing, wherein the fourth circuit is configured to apply a second signal conditioning on the second set of electrical data signals.

22. The communications cable of claim 21, wherein the second signal conditioning comprises pre-emphasizing the second set of electrical data signals.

23. The communications cable of claim 21, wherein the second signal conditioning comprises amplifying the second set of electrical data signals.

24. The communications cable of claim 21, wherein the second signal conditioning comprises amplifying and pre-emphasizing the second set of electrical data signals.

25. A communications cable, comprising:

an input connector configured to:

- connect to a data source;
- receive a first set of electrical data signals from the data source;

receive a second set of electrical data signals from the data source; and
provide a third set of electrical data signals from a data sink to the data source;
an output connector configured to:
connect to the data sink;
provide the first set of electrical data signals to the data sink;
provide the second set of electrical data signals to the data sink; and
receive the third set of electrical data signals from the data sink;
a set of one or more optical fibers coupled to the input and output connectors;
a set of one or more electrical wires coupled to the input and output connectors;
a first circuit situated within the input connector or an input housing, wherein the first circuit is configured to convert the first set of electrical data signals into one or more optical signals for transmission to the output connector by way of the set of one or more optical fibers, respectively;

a second circuit situated within the output connector or an output housing, wherein the second circuit is configured to convert the one or more optical signals received by way of the set of one or more optical fibers back to the first set of electrical data signals, respectively; and
a third circuit situated within the input connector or the input housing, wherein the third circuit is configured to apply a signal conditioning on the second set of electrical data signals.

26. The communications cable of claim **25**, wherein the signal conditioning comprises pre-emphasizing the second set of electrical data signals.

27. The communications cable of claim **25**, wherein the signal conditioning comprises amplifying the second set of electrical data signals.

28. The communications cable of claim **25**, wherein the signal conditioning comprises amplifying and pre-emphasizing the second set of electrical data signals.

* * * * *